



Model 8340

Cloud Height Indicator Laser
Ceilometer

PRODUCT MANUAL
8340-F/Rev K

**ADB
SAFEGATE**

A.0 Disclaimer / Standard Warranty

CE certification

The equipment listed as CE certified means that the product complies with the essential requirements concerning safety and hygiene. The European directives that have been taken into consideration in the design are available on written request to ADB SAFEGATE.

ETL certification

The equipment listed as ETL certified means that the product complies with the essential requirements concerning safety and C22.2 No.180:13 (R2018) regulations. The CSA directives that have been taken into consideration in the design are available on written request to ADB SAFEGATE.

All Products Guarantee

ADB SAFEGATE will correct by repair or replacement per the applicable guarantee below, at its option, equipment or parts which fail because of mechanical, electrical or physical defects, provided that the goods have been properly handled and stored prior to installation, properly installed and properly operated after installation, and provided further that Buyer gives ADB SAFEGATE written notice of such defects after delivery of the goods to Buyer. Refer to the Safety section for more information on Material Handling Precautions and Storage precautions that must be followed.

ADB SAFEGATE reserves the right to examine goods upon which a claim is made. Said goods must be presented in the same condition as when the defect therein was discovered. ADB SAFEGATE further reserves the right to require the return of such goods to establish any claim.

ADB SAFEGATE's obligation under this guarantee is limited to making repair or replacement within a reasonable time after receipt of such written notice and does not include any other costs such as the cost of removal of defective part, installation of repaired product, labor or consequential damages of any kind, the exclusive remedy being to require such new parts to be furnished.

ADB SAFEGATE's liability under no circumstances will exceed the contract price of goods claimed to be defective. Any returns under this guarantee are to be on a transportation charges prepaid basis. For products not manufactured by, but sold by ADB SAFEGATE, warranty is limited to that extended by the original manufacturer. This is ADB SAFEGATE's sole guarantee and warranty with respect to the goods; there are no express warranties or warranties of fitness for any particular purpose or any implied warranties of fitness for any particular purpose or any implied warranties other than those made expressly herein. All such warranties being expressly disclaimed.

Standard Products Guarantee

Products manufactured by ADB SAFEGATE are guaranteed against mechanical, electrical, and physical defects (excluding lamps) which may occur during proper and normal use for a period of two years from the date of ex-works delivery, and are guaranteed to be merchantable and fit for the ordinary purposes for which such products are made.

NOTE



See your applicable sales agreement for a complete warranty description.

Replaced or repaired equipment under warranty falls into the warranty of the original delivery. No new warranty period is started for these replaced or repaired products.

FAA Certified products manufactured by ADB SAFEGATE

ADB SAFEGATE L858 Airfield Guidance Signs are warranted against mechanical and physical defects in design or manufacture for a period of 2 years from date of installation, per FAA AC 150/5345-44 (applicable edition).

ADB SAFEGATE LED products (with the exception of obstruction lighting) are warranted against electrical defects in design or manufacture of the LED or LED specific circuitry for a period of 4 years from date of installation, per FAA EB67 (applicable edition). These FAA certified constant current (series) powered LED products must be installed, interfaced and powered with and through products certified under the FAA Airfield Lighting Equipment Program (ALECP) to be included in this 4 (four) year warranty. This includes, but is not limited to, interface with products such as Base Cans, Isolation Transformers, Connectors, Wiring, and Constant Current Regulators.

Contents

1. Overview	7
1.1 Models.....	7
1.2 Accessories	8
2. Theory Of Operation	9
2.1 General Description.....	9
2.2 Theory Of Operation.....	9
2.2.1 Functional Description.....	10
2.3 Modules.....	11
2.3.1 Optical Module.....	11
2.3.2 Data Acquisition Board.....	14
2.4 Fault Detection.....	16
3. Data Communication.....	17
3.1 8340 Native Format.....	17
3.2 8340 Sky Condition Format.....	20
3.3 8329 Format	21
4. Unpacking And Installation	22
4.1 Unpacking.....	22
4.2 Installation	22
4.2.1 Mechanical Mounting.....	23
4.2.2 Ceilometer Power Connection.....	24
4.2.3 Optional Heater/Blower Power Connection.....	25
4.2.4 Optional Heater/Blower Data Connection.....	25
4.2.5 Final Steps.....	25
5. Operation.....	27
5.1 Power up.....	27
5.2 Checkout.....	27
6. Maintenance.....	28
6.1 Periodic Maintenance.....	28
6.1.1 Window Cleaning — Monthly or as required.....	28
6.1.2 Blower Check — Monthly.....	28
6.1.3 Desiccant Replacement — Triannually	28
6.1.4 Blower Housing Cleaning — Annually	29
6.2 Fuse Replacement.....	29
7. Troubleshooting.....	30
7.1 Using The Status Message.....	30
8. Removal And Replacement.....	33
8.1 Removing Modules	33
8.1.1 Data Acquisition Board.....	33
8.1.2 Optical Module.....	34
8.1.3 DIN Rail Components	35
8.2 Replacing Modules.....	36

Model 8340 Ceilometer

8.2.1 Data Acquisition Board (Figure 15).....	36
8.2.2 Optical Module (Figure 16).....	36
8.2.3 DIN Rail Components	36
9. Firmware Updates	37
10. Specifications	38
11. Warranty	40
12. Drawings.....	41

Revision History

Revision	Date	Summary of Changes
E	2011 Aug 23	Added RS-485 communication, polling commands with CRC, reboot and laser temperature control warning status bits.
F	2011 Oct 1	Corrected 8329 mode baud rate
G	2011 Oct 4	Enhanced description of grounding requirements during installation.
H	2016 May 26	Updated 8340-F-019/8340-G-019 wiring diagrams to add wire colors
J	2021 Sept 29	Removed ASOS interface and associated commands
K	2025 Apr 1	ADB SAFEGATE (ECP#ADBSG-0001)



WARNING

Eye Safety

The 8340 Cloud Height Indicator (Ceilometer) uses an invisible IR laser configured as Class I according to FDA regulation CFR Title 21, Section 1040.10. This standard is system-specific, meaning that it is possible to reconfigure the system into a dangerous mode. In order to ensure continued eye safety over the life of the product:

- a. Never use external condensing optics devices, such as binoculars, lenses, etc., to look into the output aperture. Also avoid reflections from mirrors with condensing properties, i.e., mirrors with concave curvatures. The Ceilometer is safe only as long as the beam remains unmodified from its output form. Though the system is also safe with the door opened, an interlock switch prevents the laser from being fired without the door closed.
- b. Never make modifications or adjustments to the Optical Module.

Fuses

Use only replacement fuses specified in the maintenance section of this manual. In addition to observing the current rating, use only "slo blo" fuses.

Failure to do so may damage the system. If fuses blow repeatedly, a serious condition is indicated.

Equatorial Filter

An equatorial filter that prevents damage to the laser from exposure to direct sunlight is installed on every 8340 Ceilometer. This filter causes no degradation in performance.

1. Overview

The Model 8340 Laser Ceilometer measures the height and thickness of up to four cloud layers simultaneously to a distance of 40,000 vertical feet. It can also report vertical visibility.

Its precision makes it ideal for applications requiring the highest performance and reliability, such as aviation and meteorological studies.

A laser pulse is emitted towards the zenith above the Ceilometer, and the backscatter is analyzed. The laser pulse moves at speed of light, and the difference between the emission of the pulse and the return of the backscattered signal is used to calculate the altitude of each cloud base and top.

Some cloud types have poorly defined borders or a sparse composition, and are much more difficult to measure than others. Depending on the current and historical sky conditions, an adaptive algorithm determines the frequency at which the pulses should be emitted to maintain accuracy.

Weather conditions such as heavy precipitation and low clouds can lead to reporting errors in other Ceilometer designs. Proprietary algorithms and digital techniques developed by ADB Safegate based on 20 years of cloud detection research and manufacturing experience are used by the Model 8340 Ceilometer to provide accurate information even in difficult circumstances.

Sensing circuits and optimization algorithms control the pulse frequency, output power, and temperature of the laser itself in order to extend its life dramatically.

The 8340 is enclosed in a NEMA 4X electro-polished 304 stainless steel package that will stand up to the harshest environmental conditions from corrosive marine air to blowing desert sand. The 8340 is designed to last.

Extensive Self-Diagnostics

An array of self-tests executed in the background during operation detects faults and reports them, along with identifying the replaceable module associated with the fault. Errors are reported both visibly in the sensor and electronically through the output string.

The serviceability design of the 8340 was influenced by our customers. Their input was used to engineer the package and configuration of "Line Replacement Units" so that repairs can be accomplished in 30 minutes or less.

1.1 Models

Two 8340 models are available.

Model	Description
8340-F	100–120 V AC
8340-G	200–240 V AC

1.2 Accessories

The following accessories are available for the Model 8340 Ceilometer.

Part Number	Description
83405-00	Battery Backup Kit
83406-00	100–120 V AC Heater/Blower for use with 8340-F
83407-00	200–240 V AC Heater/Blower for use with 8340-G
M488261-00	Ceilometer Mounting Kit
M491742-00	Ceilometer Data Cable
M491745-01	50 ft Ceilometer Power Cable (Ceilometer power connector to bare wires)
M491762-02	Heater/Blower Data and Power Cable
M491763-01	Service Port Cable
M028181-00	Desiccant

2. Theory Of Operation

2.1 General Description

The Model 8340 Ceilometer (also known as Cloud Height Indicator, or CHI) is designed for fixed installation at airports, meteorological stations, or anywhere reliable cloud ceiling information is required. The Ceilometer monitors sky conditions continuously and reports up to four detected cloud bases and depths to an altitude of 40,000 feet above ground level. If the Ceilometer cannot “see” beyond a height of 3,000 feet, meaning that vertical visibility is restricted but there is no discernible cloud base, the Ceilometer outputs a vertical visibility value. Vertical visibility is defined as follows.

Extinction is given by:

$$I = I_0 e^{-\sigma z}$$

where σ is the extinction coefficient (corresponds to the water particulate density in the air). The vertical visibility is then found by solving:

$$\frac{I}{I_0} = 0.05 = \int_0^{\text{vertical visibility}} e^{-\sigma z} dz$$

In other words, that distance where 95% of the initial laser beam has been extinguished by scattering.

The 8340 works in accordance with the principal of optical radar, or LIDAR. A laser pulse is emitted at a maximum rate of 1 kHz vertically into the atmosphere, and the resulting backscattering is analyzed for water density. Clouds are identified when the water density changes abruptly. Vertical visibility is determined by integrating the near field water density pattern. Proprietary algorithms enable the unit to achieve superior performance while still maintaining an eye-safe laser light level.

The 8340 is comprised of modular, field-replaceable units. Internal self-test routines identify faults and isolate them to the module level.

WARNING



The Model 8340 Ceilometer is a Class I laser configuration, which is eye-safe in all conditions except when viewed through optical instrumentation, such as binoculars or any other condensers. Never view the optical radiation through such devices or serious eye damage may result.

2.2 Theory Of Operation

A laser pulse is emitted into the atmosphere by the transmitter, and a high-speed analog-to-digital converter is used to record the backscatter returns to the receiver. The receiver is adjustable, so that gains and response parameters can be varied in an adaptive sense. A number of pulse bursts are obtained, depending on the current and historical sky conditions. Using the speed of light, the altitude of the clouds may then be determined.

Vertical visibility is determined by integrating the total water density in the near field with calibration coefficients obtained by comparing the Ceilometer with visibility sensors and present weather sensors that have been maintained in accordance with NBS and FAA guidelines.

A dirty window detector is used to control a heater/blower that keeps the optical windows free of dust, water, and snow. When the Ceilometer windows reach a point where they require manual cleaning, an alert is output over the communication bus. If the windows are not cleaned following the alert and the accuracy of the collected data becomes questionable, the Ceilometer sends a failure message.

The “effective range” of the Ceilometer—the altitude above which the results are uncertain—is continually monitored using sophisticated signal analysis techniques. In heavy fog, for instance, the Ceilometer can only see through so much water droplet density before the laser beam has been completely depleted (scattered into space). The effective range is useful to know, since there may be clouds above that altitude that the Ceilometer cannot see.

Some clouds are much more difficult to detect than others, due, for example, to poorly defined borders or a sparse composition. The proprietary algorithms used in the 8340 are adaptive to these conditions, allowing the Ceilometer to provide accurate information even in difficult circumstances.

2.2.1 Functional Description

The 8340 Ceilometer is designed with interchangeable modules to make it straightforward to maintain in the field (see Figure 1). Extensive internal self-testing identifies problems and provides detailed information concerning the nature of the problem, including the specific module with which the problem is associated.

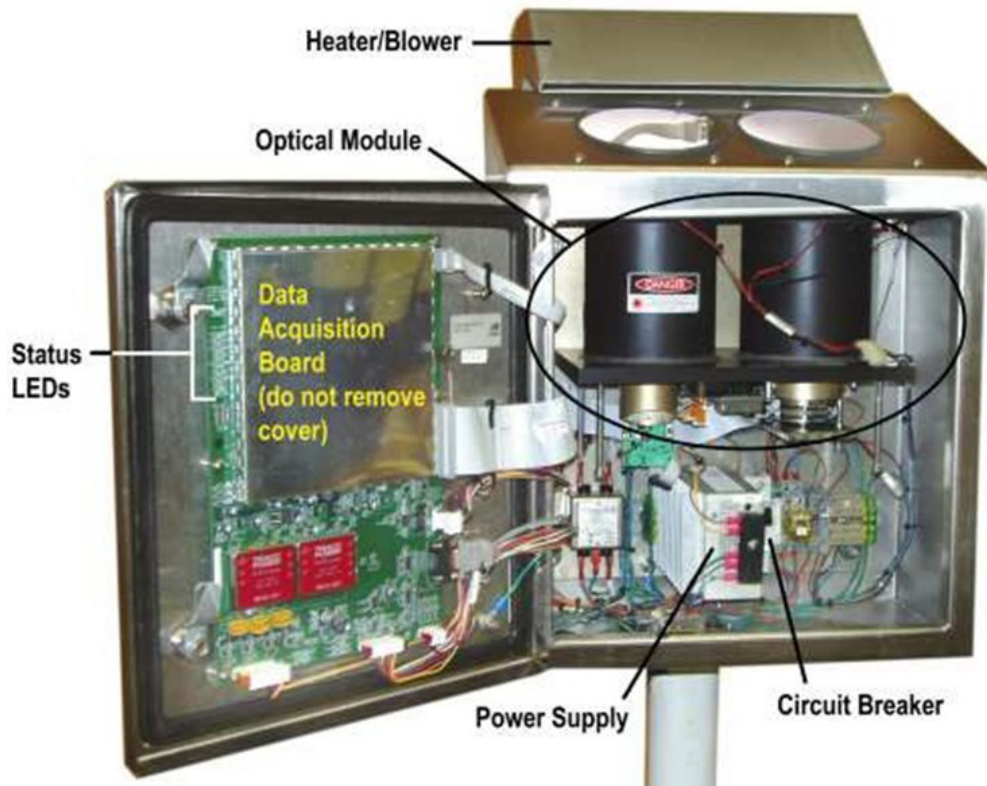

Figure 1. Ceilometer Components

2.3 Modules

The Model 8340 Ceilometer is made up of the following major modules.

- The **Optical Module** (M403434-01) contains the laser, the receiver, and the dirty window detector electronics, as well as the condenser lenses, interference filter, and high voltage switching regulators.
- The **Data Acquisition Board** (M404848-02) contains the microprocessor, flash A/D, system A/D, communication electronics and memory.
- The **Power Supply** (M438200-00) accepts AC power and provides 13.5 V DC to the Ceilometer electronics.
- A **Circuit Breaker** (M442095-00) is installed between the AC power input and the power supply.
- The optional **Heater/Blower Assembly** contains the heater and blower.

2.3.1 Optical Module

WARNING



The optical module is assembled at the factory, and cannot be adjusted by the user.

Mechanical alignment of the receiver and transmitter is performed at the factory, and care should be taken to avoid dropping or jarring the module. The Optical Module does not contain any field-serviceable parts or adjustments.

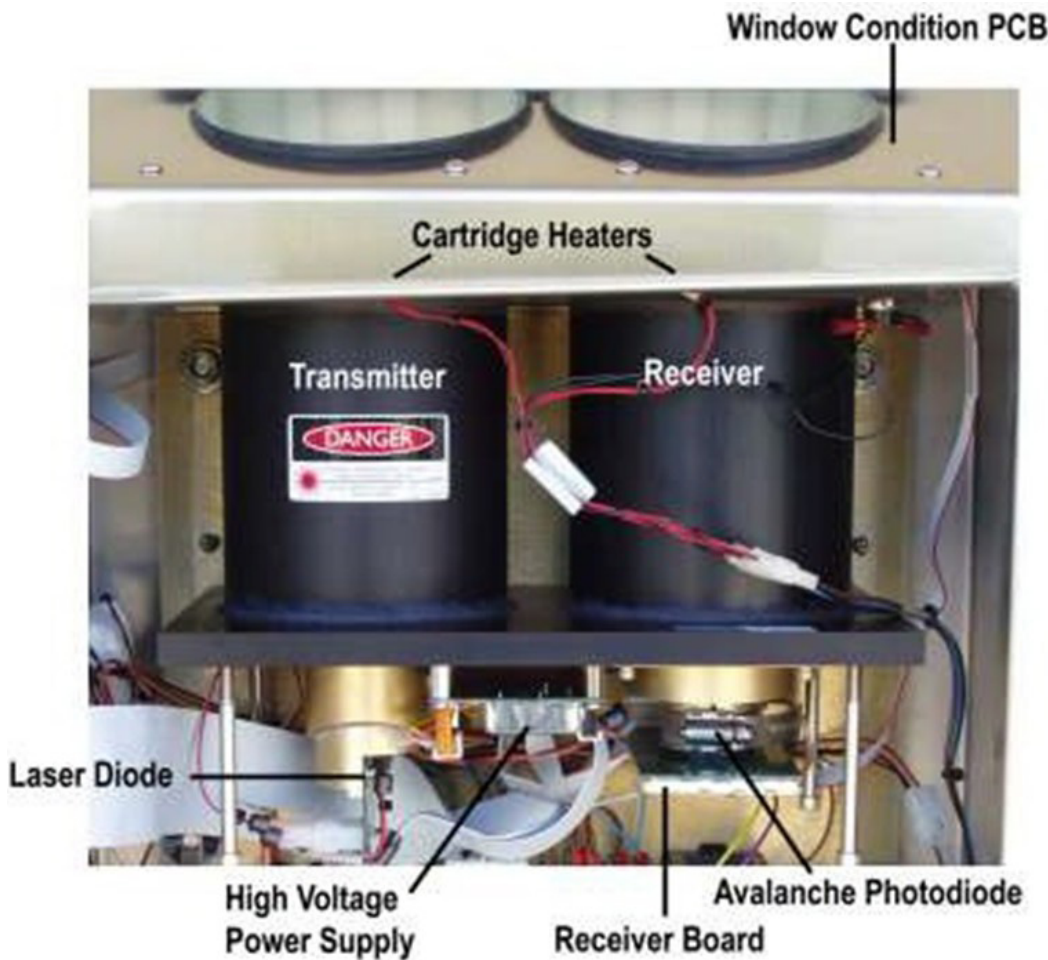

Figure 2. Optical Module

Model 8340 Ceilometer

The optical module consists of two 4" aspherical condenser lenses mounted atop a brazed aluminum cylinder frame. The module attaches to the base of the Ceilometer with four connectors that are easily removed in the field.

The transmitter uses a 905 ± 10 nm laser operated at a temperature of approximately 35°C . A special filter is used to protect the laser diode from direct sunlight.

The receiver uses a 3 nm wide interference filter and several small lenses to focus the light onto an avalanche photodiode (APD) run at voltages up to 600 V.

Two high-voltage DC output switching voltage regulators provide bias for both the laser and the APD.

Special circuits ensure that the Ceilometer's eye-safe parameters are maintained under all operating conditions.

Extensive self-testing electronics continuously measure laser output power, receiver sensitivity, window conditions, voltage levels, and operating temperatures. Anomalies are reported over the communication bus to the end user.

Two cartridge heaters are inserted in the top of the optical module to maintain temperature regulation over the Ceilometer's wide operating temperature range.

The window condition monitoring board is mounted on the upper plate of the optical module (see Figure 3). This board contains IRLEDs that are used to determine when the windows need cleaning, a receiver test LED, and a temperature probe used to regulate the AC heaters.

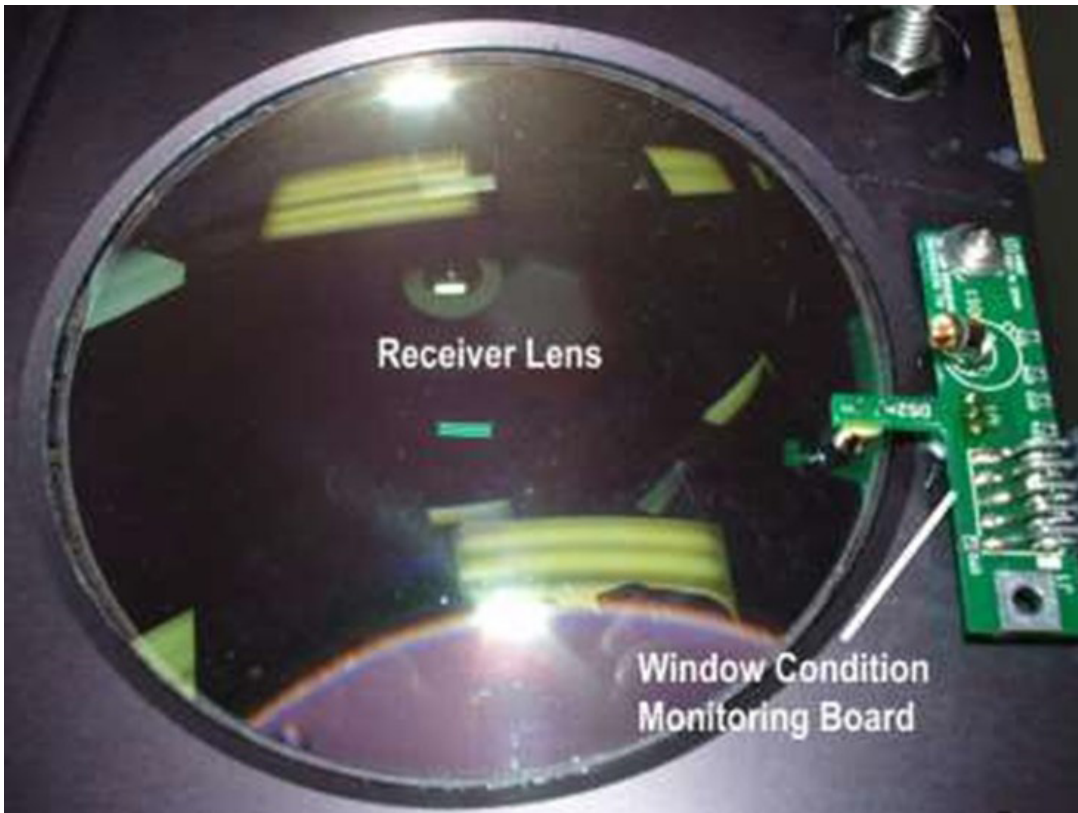

Figure 3. Window Condition Monitoring Board

Externally Visible Ceilometer Status LEDs

A small circuit board is mounted inside the top of the Ceilometer enclosure, and is visible from outside the unit through the transmitter window. Three LEDs on this board indicate Ceilometer status. Figure 4 shows their location in the transmitter windows, and Table 1 explains their meaning.

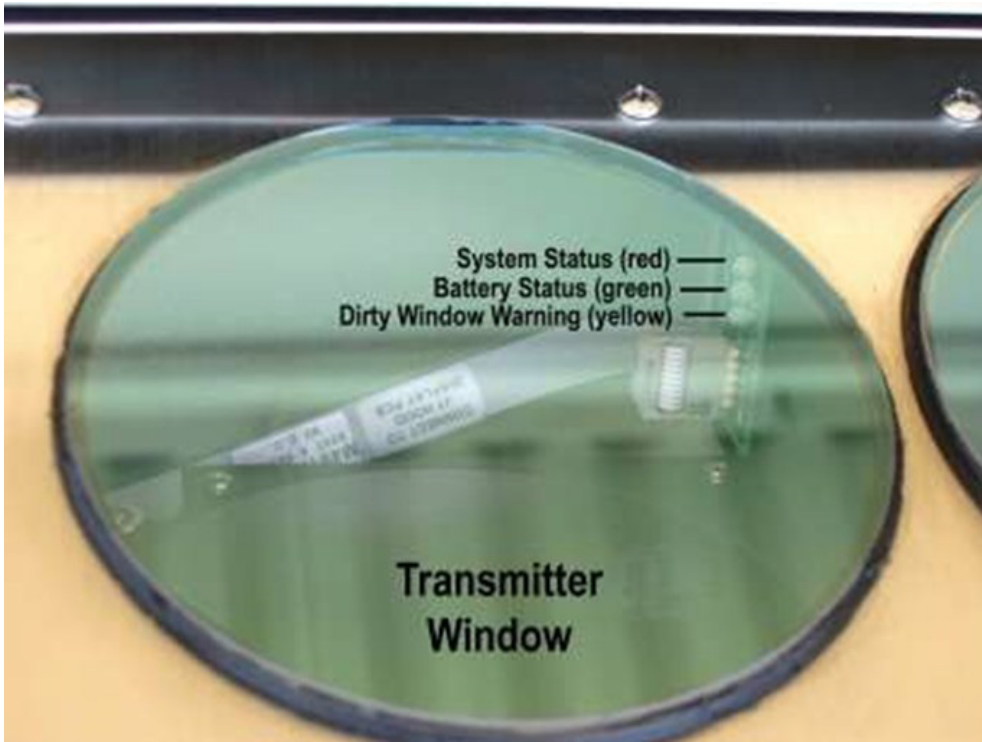

Figure 4. Ceilometer Status LEDs Location

Name	Meaning
SYSTEM STATUS (red)	a. ON continuously when Ceilometer is in standby mode with no failures or warnings b. OFF when Ceilometer is powered off c. FAST BLINKING when Ceilometer is outputting laser radiation d. SLOW BLINKING when a warning or failure condition exists e. FAST AND SLOW BLINKING together implies a warning level fault and outputting laser radiation
BATTERY STATUS (green)	ON when DC power is good
DIRTY WINDOW WARNING (yellow)	ON when windows need cleaning

Table 1. Ceilometer Status LEDs Meaning

Optical Windows

The Ceilometer's two optical windows located in the top of the box are made of high precision float glass, and it is imperative that they be clean and free of scratches and cracks.



CAUTION

Never clean the windows with abrasive rags or cloths, and always use isopropyl alcohol. Do not use cleaners, such as Windex, or window defoggers, such as Rain-x.



CAUTION

It is important to keep water out of the interior of the Ceilometer. Do not open the door during precipitation events—once water is introduced into the interior, it is very difficult to eliminate. Water inside the unit may cause condensation on the inside glass surfaces, and may leave a residue behind on the optics.

2.3.2 Data Acquisition Board



NOTE

A metal cover protects a portion of the Data Acquisition Board and should never be removed by the user.

A 40 Msp/s flash A/D is connected to the receiver. A Motorola Coldfire microprocessor controls all Ceilometer functions, and outputs messages over the communication bus in RS-232/RS-485 format.

The basic system operating parameters are shown below, along with the available settings and default settings.

Parameter	Possible Settings	Default Setting
Output Interval	30, 60, 120 sec.	30 sec.
Data Format	ADB Safegate 8340 format; 40,000', auto output	ADB Safegate 8340 format; 40,000', auto output
Control	Local, remote	Local

Table 2. System Operating Parameters

A row of red LEDs along the edge of the board indicates the status of the Ceilometer. Their functions are shown in Table 3.

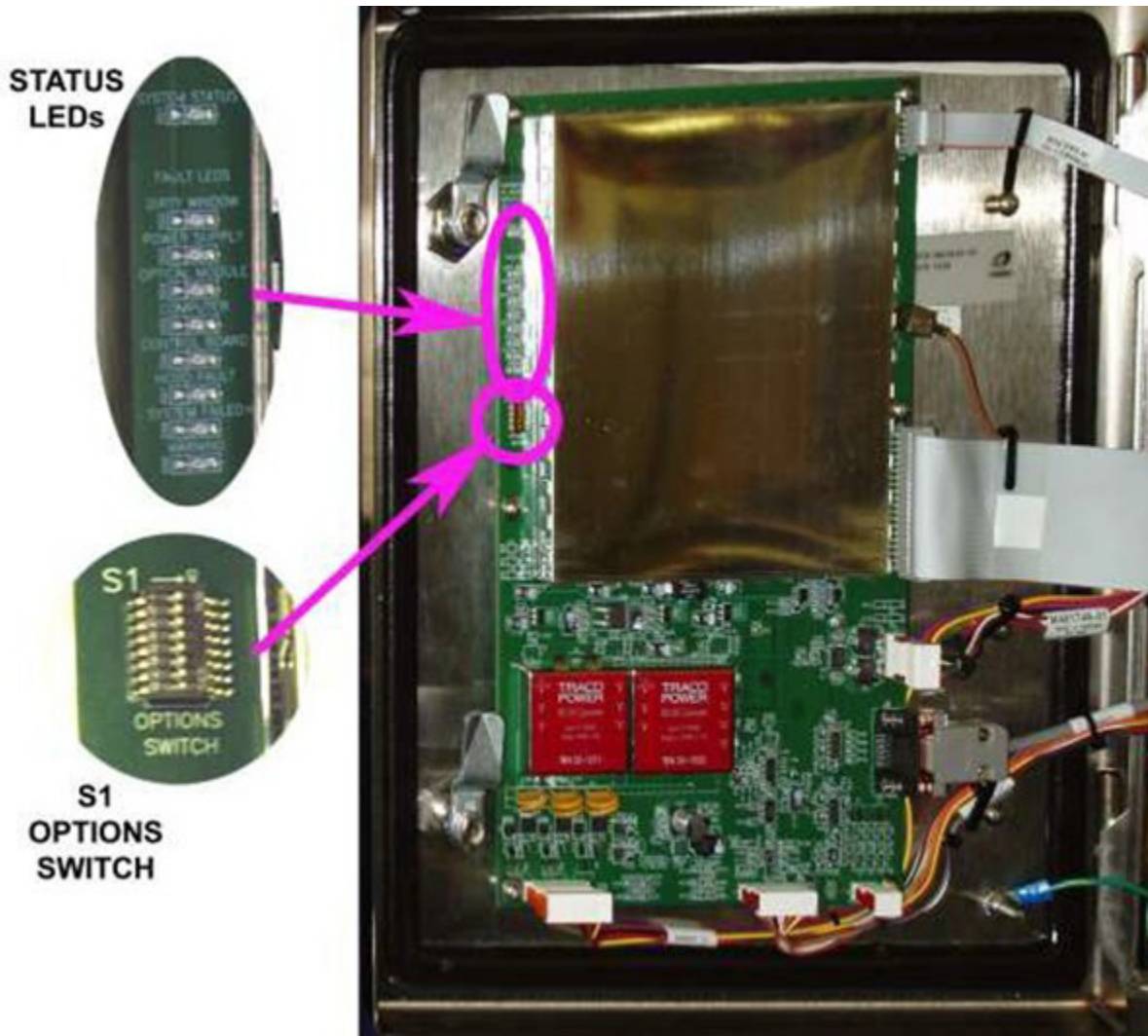

Figure 5. Data Acquisition Board Status LEDs and S1 DIP Switch

Name	Meaning
DIRTY WINDOW	Dirt or moisture buildup on windows; windows need cleaning
POWER SUPPLY	Fault in power supply module
OPTICAL MODULE	Fault in optical module
COMPUTER	On when performing algorithm calculations
CONTROL BOARD	Fault in Data Acquisition Board
HOOD FAULT	Interlock switch open
SYSTEM FAILED	Fault condition; must be corrected to return Ceilometer to operation
WARNING	Warning of deteriorating operation; Ceilometer will continue operating but should be checked as soon as possible

Table 3. Data Acquisition Board LEDs

Model 8340 Ceilometer

An eight-position DIP switch is used to set system configuration. Only switches 1–6 are used. The positions of the other switches have no effect. An arrow at the top of the switch shows the ON position for the individual switches.

Mode	1	2	3	4	5	6
30 second reporting	X	X	ON	ON	X	X
60 second reporting	X	X	OFF	ON	X	X
120 second reporting	X	X	OFF	OFF	X	X
8340 Native Format	ON	ON	X	X	X	X
8329 Format	OFF	ON	X	X	X	X
8340 Sky Condition Format	OFF	OFF	X	X	X	X
300 Baud	X	X	X	X	OFF	OFF
1200 Baud	X	X	X	X	ON	OFF
4800 Baud	X	X	X	X	OFF	ON
9600 Baud	X	X	X	X	ON	ON

Table 4. S1 DIP Switch Settings

2.4 Fault Detection

When a fault is detected during the Ceilometer's self-testing, a fault message is output over the communication line. Ceilometer faults are grouped into two categories.

- **Warnings** indicate the need for attention, less urgent than a Failure.
- **Failures** indicate a problem that may compromise the accuracy of cloud data. The problem should be addressed immediately.

The Ceilometer will remain operational while a Warning is active, but the problem should be addressed as soon as possible to prevent compromised operation or exacerbation of the Warning to a Failure. When a fault is detected, a message is output at every reporting interval. The message will be repeated until the fault is corrected.

3. Data Communication

The Ceilometer’s microprocessor controls the data output over an asynchronous RS-232 or RS-485 interface. The data can be output to a data display unit, a controller, or any other peripheral capable of reading the output signal and decoding the format. The Ceilometer supports several data packages. This chapter describes the various formats.

3.1 8340 Native Format

Communication Parameters

A data package is available at every reporting interval. The required settings for communicating with the Ceilometer are shown in Table 5.

Parameter	Setting
Baud Rate	9600 bps
Data Bits	8
Parity	None
Stop Bits	1
Handshaking	None

Table 5. 8340 Ceilometer Communication Settings

Data Format

The 8340 Native Data format is output from the Ceilometer in a data string consisting of eight fields.

Output Data String	
TR1 AAAAAA HHHHH TTTT HHHHH TTTT HHHHH TTTT HHHHH TTTT VVVV RRRRR	
Character Sequence	Meaning
TR1	TR1 is an identifier that enables the system to be put onto a universal bus. It communicates the data source (8340 Ceilometer) to the data receiver
AAAAAA	Status message (see Troubleshooting for a definition of the status message)
HHHHH	Cloud height in feet
TTTT	Penetration depth in feet
VVVV	Vertical visibility
RRRRR	Range setting in feet

Table 6. 8340 Native Data Output Data Format

Poll Commands

The Ceilometer can be polled when in its normal mode of operation (TR1 outputs). The Ceilometer can be set into polled mode from either a configuration value or via a poll command.



NOTE

The Ceilometer will stay in polled mode when the DCP or Standalone poll commands are used until a reboot occurs.

Each poll command is followed by the address of the device and a carriage return and line feed. Each poll command has a CRC 16 appended to the end of the message

The poll commands are summarized below.

CHIL<ADDR> <CR> <LF> – DCP Poll Command

Output Data String	
XXXXX YYYYY ZZZZZ VVVVV SSSSS N 0 0 0 CCCC	
Character Sequence	Meaning
XXXXX	First cloud base
YYYYY	Second cloud base
ZZZZZ	Third cloud base
VVVV	Vertical visibility
SSSSS	Status message (see Troubleshooting for a definition of the status message)
N 0 0 0	Report unchanged count
CCCC	CRC 16

CEILO<ADDR> <CR> <LF> – Standalone Poll Command

Output Data String	
TR1XX SSSSS HHHHH TTTT HHHHH TTTT HHHHH TTTT HHHHH TTTT VVVV RRRRR CCCC	
Character Sequence	Meaning
XX	Address
SSSSS	Status message (see Troubleshooting for a definition of the status message)
HHHHH	Cloud height in feet
TTTT	Penetration depth in feet
VVVV	Vertical visibility
RRRRR	Range setting in feet
CCCC	CRC 16

CHIIDN? <ADDR> <CR> <LF> – Identification Poll Command

Output Data String	
ADB Safegate 8340/8340 Ceilometer X.YY CCCC	
Character Sequence	Meaning
X.YY	Ceilometer version
CCCC	CRC 16

CHICONFIG<ADDR> <CR> <LF> – Configuration Request Poll Command

- Returns the active configuration that is stored in flash followed by a CRC 16

Return String	
000799a58f00003000ef0bb862620308275d11090080205740015a5ae60100ffff CCCC	
Character Sequence	Meaning
Sample string	Active configuration stored in flash memory
CCCC	CRC 16

CHIREBOOT<ADDR> <CR> <LF> – Reboot Poll Command

- Reboots the Ceilometer

3.2 8340 Sky Condition Format

The 8340 Sky Condition Format provides real-time reports of cloud bases and depths as well as the Sky Condition based on the NWS ASOS Sky Condition algorithm.

The Sky Condition algorithm uses a weighted average of 30-second cloud hit reports over a 10-minute period to determine the cloud cover. The output of the Sky Condition algorithm produces results such as "OVC020 BKN230" representing an Overcast layer at 2,000 feet and a Broken layer at 23,000 feet. Notice that the height is reported in hundreds of feet. Layers are always reported in ascending order, and may contain up to four distinct layers. The Sky Condition output field from the Ceilometer is acceptable for METAR reporting based on the ICAO Annex 3 requirements.

The possible Sky Condition outputs are listed in Table 7.

Parameter	Definition
MM	Not enough data exists to produce an output. 30 minutes of valid reports are required to produce a Sky Condition output.
CLR	Less than 6% coverage of any layer.
FEW	More than 6% coverage and less than 25% for the specified layer.
SCT	More than 25% coverage and less than 50% for the specified layer.
BKN	More than 50% coverage and less than 87.5% for the specified layer.
OVC	More than 87.5% coverage.

Table 7. Sky Condition Output Values

A data package is available every 30-seconds. The required settings for communicating with the Ceilometer are the same ones shown in Table 5 for the 8340 Native Data format.

Data Format

The 8340 Sky Condition Format is output from the Ceilometer in a data string consisting of seven fields.

Output Data String	
TR1 AAAAAA HHHHH TTTT HHHHH TTTT HHHHH TTTT HHHHH TTTT VVVV RRRRR ,SKYCOND	
Character Sequence	Meaning
TR1	TR1 is an identifier that enables the system to be put onto a universal bus. It communicates the data source (8340 Ceilometer) to the data receiver
AAAAAA	Status message (see Troubleshooting for a definition of the status message)
HHHHH	Cloud height in feet
TTTT	Penetration depth in feet
VVVV	Vertical visibility
RRRRR	Range setting in feet
SKYCOND	The Sky Condition string utilizing the condition codes as described above. Heights are reported in 100's of feet. For example "SCT003 BKN022" indicates that there is a scattered layer at 300 feet and a broken layer at 2,200 feet. The Sky Condition string is terminated with a comma ','.

Table 8. 8340 Sky Condition Output Data Format

3.3 8329 Format

The Model 8340 Ceilometer may replace an Model 8329 Ceilometer in an existing AWOS. The 8329 Format enables the Model 8340 Ceilometer to continue report data using the 8329 format used by the Model 8329 Ceilometer without making changes to the AWOS.

Communication Parameters

A data package is available at every reporting interval. The required settings for communicating with the Ceilometer are shown in Table 9 The AWOS 200 requires a 300 bps baud rate and the AWOS 900 requires a 1200 bps baud rate.

Parameter	Setting
Baud Rate	300–9600 bps (programmable)
Data Bits	8
Parity	None
Stop Bits	1
Handshaking	None

Table 9. 8329 Format Ceilometer Communication Settings

Data Format

The 8399 data are output by default in a data string as explained in Table 10.

Output Data String	
<SOH> <LF> <CR> <SP> <SP> TR1 <SP> <SP> AAAA <SP> <SP> HHHH <SP> <SP> TTT <SP> <SP> HHHH <SP> <SP> TTT <SP> <SP> VVVV <SP> <SP> RRRR <SP> <LF> <CR> <ETX> <BCC> <EOT>	
Character Sequence	Meaning
TR1	TR1 is an identifier that enables the system to be put onto a universal bus. It communicates the data source (8340 Ceilometer) to the data receiver
AAAA	Status message
HHHH	Cloud height in feet
TTT	Penetration depth in feet
VVVV	Vertical visibility
RRRR	Range setting in feet

Table 10. 8329 Output Data Format

4. Unpacking And Installation

4.1 Unpacking

The Model 8340 Ceilometer is a precision optical/electronic instrument and should be handled with extreme care at all times.

When the equipment is received, check that all parts listed on the packing slip are accounted for, and inspect the equipment for visible transport damage. Report any damage or discrepancies to ADB Safegate Customer Service.



Figure 6. Ceilometer in Shipping Container



CAUTION

The equipment must be kept dry and not exposed to temperatures below -50°C or above $+70^{\circ}\text{C}$ during shipment and storage.

4.2 Installation

The 8340 must be firmly mounted to a vertical $2\frac{1}{2}$ " pipe for proper operation. Any movement of the 8340 due to wind or other causes will reduce the accuracy of the Ceilometer. The Ceilometer should be installed in an open area away from trees, buildings, or other obstructions. When installing the Ceilometer on its pole, orient it with the windows facing toward the North (South in the Southern Hemisphere) to reduce the amount of direct sunlight on the windows (see Figure 6).

4.2.1 Mechanical Mounting

Ceilometer

The Ceilometer mounts on the mast using the M488261-00 Mounting Kit. Refer to drawing M488261-00-007 at the back of this manual and to Figure 6 during installation.

Mount the Ceilometer on the mast with the top of the enclosure 5'6" (167 cm) from ground level, or at least 3 feet (1 meter) above the maximum snow level using Mounting Kit M488261-00.

Ground Cable

In order for the Ceilometer's built-in lightning protection to function properly, the Ceilometer must be grounded. To install grounding, follow the steps below (see Figure 7).

1. Drill and tap a ¼ -20 hole in the mast. Install a grounding clamp in the hole.
2. Connect one end of a length of ground cable (4 AWG multi-strand insulated wire, available from ADB Safegate as P/N T605000), to the grounding clamp on the mast.
3. Connect the other end of the ground cable to the ground clamp on the underside of the Ceilometer.
4. Finally, connect a bare copper ground wire between the ground clamp on the mast and an installed ground rod.

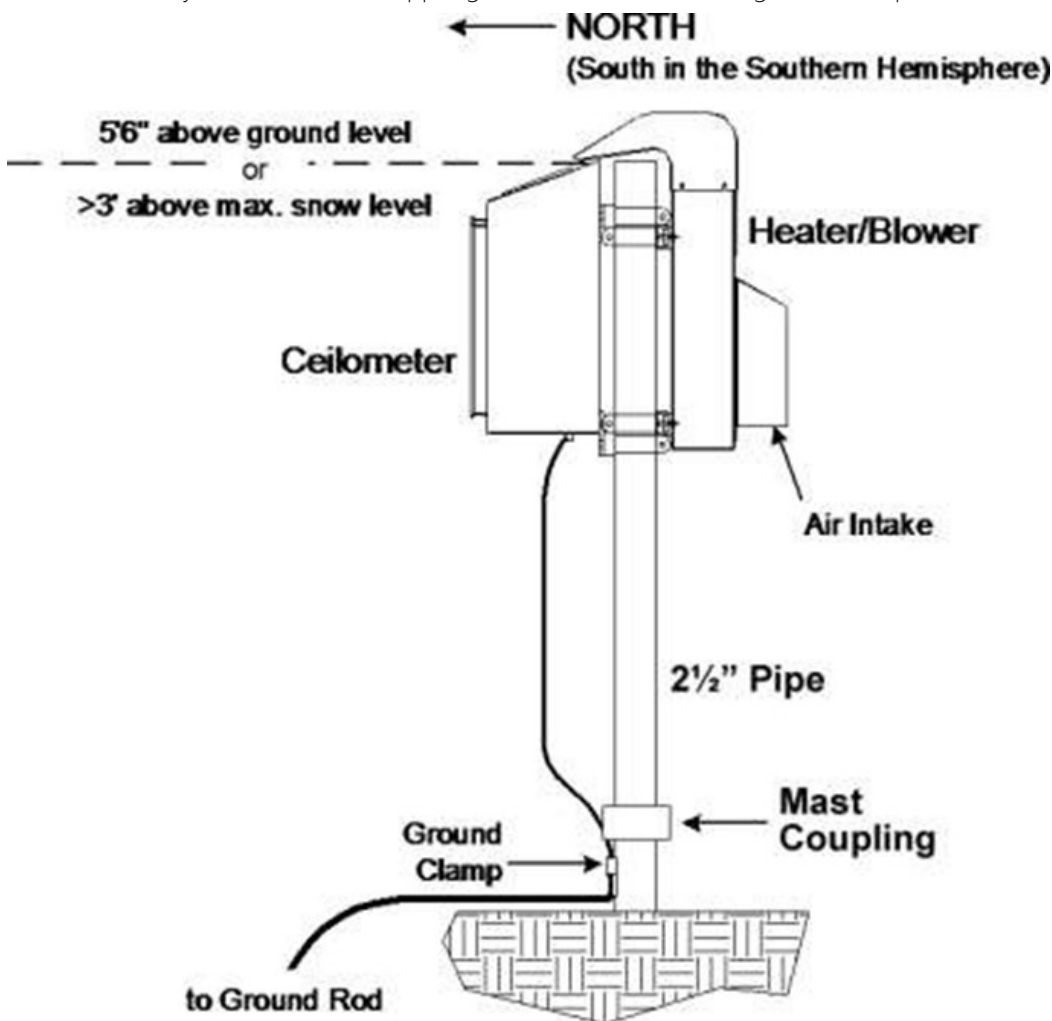
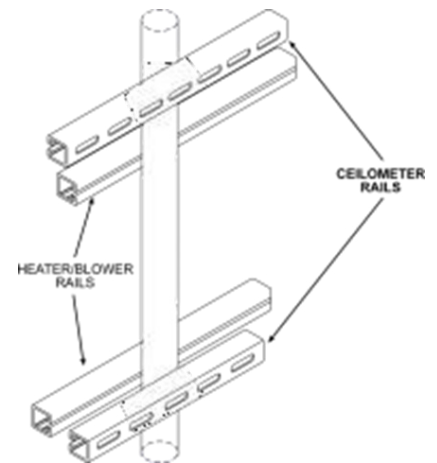

Figure 7. Ceilometer Mounting

Optional Heater/Blower

The optional Heater/Blower mounts on the mast using the supplied Unistrut and clamps.

1. Mount the Heater/Blower on the mast as shown in installation drawing 83406-00-007 (100-120V) or 83407-00-007 (200-240V) at the back of this manual.
2. Note that the Heater/Blower installs so that its mounting brackets fit between the Ceilometer's mounting brackets. That is, the Heater/Blower's top bracket installs directly beneath the Ceilometer's top bracket, and the its bottom bracket installs directly above the Ceilometer's bottom bracket.
3. Install the blower hood onto the blower unit: The screws are already installed into the blower unit; loosen the screws and slide the blower hood onto the screws. Tighten the screws.



4.2.2 Ceilometer Power Connection



WARNING

Ensure that the circuit breaker for the Ceilometer in the main power distribution box is in the OFF position.

1. Set the main circuit breaker in the 8340 to the OFF position (see Figure 1).
2. Connect the power cord's circular connector to the INPUT POWER connector on the underside of the Ceilometer (see Figure 8).
3. Connect the other (unterminated) end of the cable to a suitable AC source according to wiring diagram 8340-F-019 or 8340-G-019.

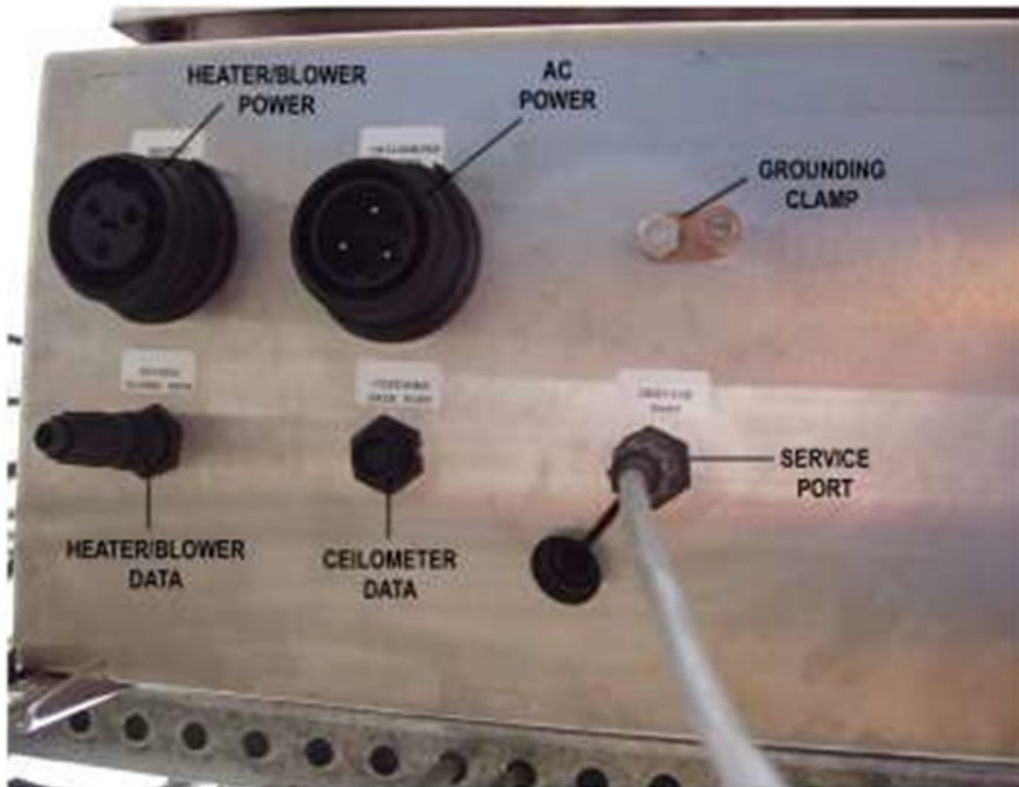

Figure 8. Ceilometer Connectors

Ceilometer Data Connection

1. Connect the data cable's circular connector to the CEILOMETER DATA connector on the underside of the Ceilometer (see Figure 8).
2. Connect the other (unterminated) end of the cable to the data collection unit (Model 1190 DCP in AWOS installations) according to wiring diagram 8340-F-019 or 8340-G-019. If connecting to the AWOS DCP, refer to the Model 1190 Data Collection Platform User's Manual for connection instructions at the DCP.

4.2.3 Optional Heater/Blower Power Connection

Connect the optional Heater/Blower's power cord to the HEATER/BLOWER POWER connector on the underside of the Ceilometer (see Figure 8).

4.2.4 Optional Heater/Blower Data Connection

Connect the optional Heater/Blower's data cable to the HEATER/BLOWER DATA connector on the underside of the Ceilometer (see Figure 8).

4.2.5 Final Steps

1. Ensure that the circuit breaker on the power supply is in the "ON" position (see Figure 9).
2. Verify that DIP switch "S1" on the Data Acquisition Board is configured correctly (refer to S1 Settings in Table 4).



Figure 9. Circuit Breaker in ON Position

3. The desiccant package (M028179-00) is secured inside the Ceilometer by tie-wraps. To preserve the desiccant material, the package is sealed within a plastic bag during shipment. Remove and discard the plastic bag, then replace the desiccant package in its tie-wrap holder (see Figure 10).

Model 8340 Ceilometer

- The desiccant package (M028179-00) is secured inside the Ceilometer by tie-wraps. To preserve the desiccant material, the package is sealed within a plastic bag during shipment. Remove and discard the plastic bag, then replace the desiccant package in its tie-wrap holder. Figure 10 shows the desiccant bag at the upper left corner near the optical module. The desiccant may also be placed in the lower right area of the Ceilometer enclosure with the indicator paper above the desiccant to be readily visible.



Figure 10. Desiccant Installation

- Close and fasten the enclosure door.

5. Operation

5.1 Power up

1. Before closing the Ceilometer door, make sure the circuit breaker switch is in the "ON" (up) position (Figure 9).
2. Apply prime power.

5.2 Checkout

After powering on the Ceilometer, check the status LEDs (see Figure 4) to verify proper operation.

Name	Meaning
SYSTEM STATUS (red)	<ol style="list-style-type: none"> a. ON continuously when Ceilometer is in standby mode with no failures or warnings b. OFF when Ceilometer is powered off c. FAST BLINKING when Ceilometer is outputting laser radiation d. SLOW BLINKING when a warning or failure condition exists e. FAST AND SLOW BLINKING together implies a warning level fault and outputting laser radiation
BATTERY STATUS (green)	ON when DC power is good
DIRTY WINDOW WARNING (yellow)	Lighted (yellow) when windows need cleaning

Table 11. Ceilometer Status LEDs Meaning

The Status LED will begin slow blinking a few seconds after prime power is applied to the unit. If the LED does not illuminate, check prime power, circuit breaker CB1, and the fuses inside the enclosure.

At power-up, the laser is not up to temperature, which will cause the Status LED to blink slowly until the laser reaches its operating temperature. Depending on the outside temperature, it may take a few minutes for the laser to reach its required operating temperature. Slow blinking of the STATUS LED beyond this point indicates that a problem is present (for more details, see the Troubleshooting section of this manual). If the status LED continues to blink slowly for an indefinite period of time, consult the status word in the output message, and open the Ceilometer to check the Data Acquisition Board LEDs for indications of a module fault. Remember to check all connections to ensure they are sound. The most common cause of errant system behavior at power-up is poor connections.

Once the laser begins firing during cloud measurement, the Status LED will change to a fast blinking mode. This will generally last fifteen seconds for each thirty-second measurement frame.

If the unit exhibits fast blinking and slow blinking together, a warning condition exists. This means that there is a problem with the system, but it is not severe enough to require a Ceilometer shutdown and sky conditions can still be measured to a satisfactory level of confidence.

From a remote location, the output message can be checked to verify proper operation. The status word in the output message should show the same indications as the Status LED described above.

6. Maintenance

6.1 Periodic Maintenance

6.1.1 Window Cleaning — Monthly or as required

Clean the transceiver windows at least once per month (more frequently if local conditions warrant), or when the status message so indicates. Note that a dirty window warning message may also appear during rain, snow, and fog conditions - whenever the internal electronics measure a certain amount of window obfuscation.



CAUTION

Use only isopropyl alcohol to clean the windows. Commercial cleaners containing ammonia will degrade the optical coating on the windows, resulting in degraded sensitivity (higher altitude clouds will no longer be detected).

6.1.2 Blower Check — Monthly

Each time the windows are cleaned, check blower operation by covering the receiver window with an opaque object (such as a sheet of paper) and verifying that the blower turns on. This may take up to 30 seconds.

Clear the Heater/Blower air intake and output nozzle (see Figure 11) of any impediments, such as spider webs, leaves, or other matter.

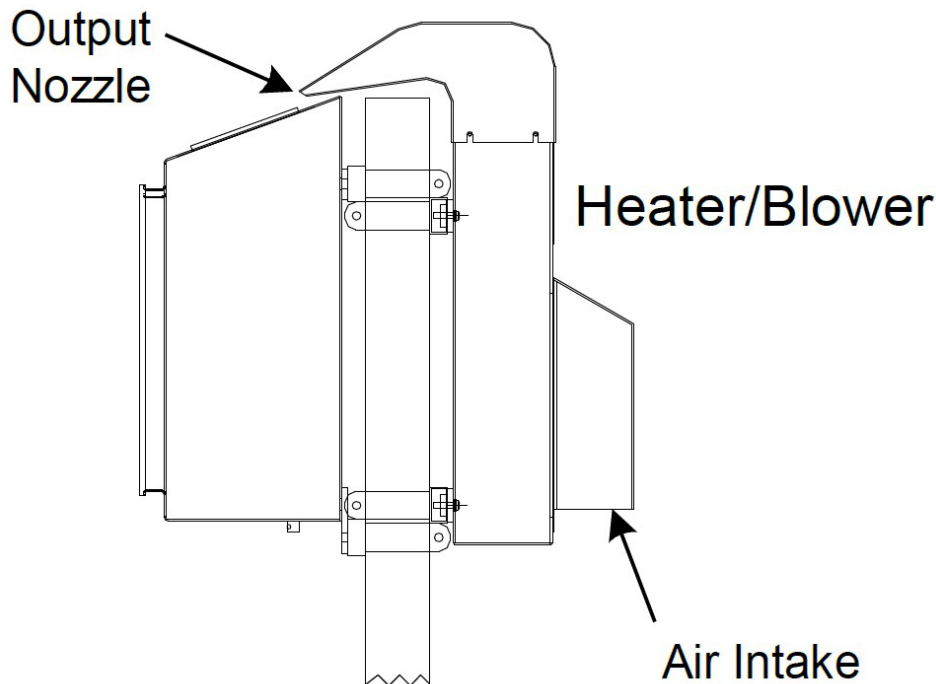

Figure 11. Heater/Blower Maintenance Areas

6.1.3 Desiccant Replacement — Triannually

As a routine maintenance task, replace the desiccant package triannually. If the enclosure door is opened during maintenance or service at any time, replace the desiccant package (M028179-00) before closing the door for the final time. To preserve the desiccant material, the package is sealed within a plastic bag during shipment. Remove and discard the plastic bag, then replace the desiccant package in its tie-wrap holder (see Figure 10).

6.1.4 Blower Housing Cleaning — Annually

During annual maintenance, clean the blower housing as follows:

1. Remove the six Phillips screws from the blower housing's rear panel, and remove the rear panel.
2. Clear the inside of the blower housing of any debris. Be sure to check the output nozzle and clear any debris from there as well.
3. Replace the rear panel and secure with six screws removed in Step 1.

6.2 Fuse Replacement

The Ceilometer contains two replaceable fuses, F1 and F2, located on the DIN rail to the right of the Circuit Breaker. When replacing fuses, use only fuses rated as follows:

F1: 10A, 250V; 5 X 20 mm, SLO-BLO

F2: 5A, 250V; 5 X 20 mm, SLO-BLO

To replace either fuse:

1. Open the fuse housing by lifting up on the tab at the bottom of the housing. The fuse is located inside the housing cover (see Figure 12).
2. Press from the right side to pop the fuse free from its socket.
3. Install a properly rated fuse into the socket from the left side and press into place.
4. Close the housing cover, ensuring it snaps shut.

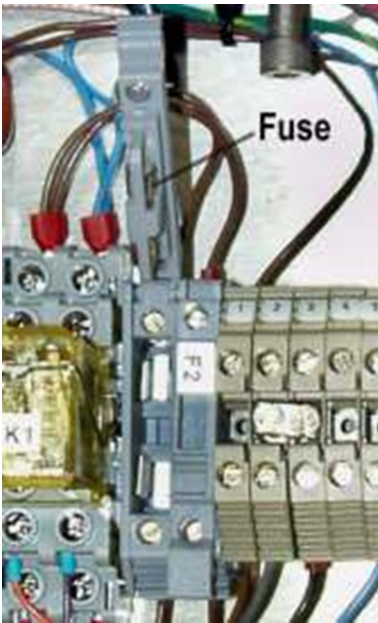

Figure 12. Fuse Replacement

7. Troubleshooting

7.1 Using The Status Message

The first step in troubleshooting Ceilometer problems is consulting the output message's status message. This is a six-character hexadecimal code that follows immediately after the TR1 identifier in the data string (see Data Format on page 13). The status codes are identified in the table below.

Status Code	Meaning
800000	failure condition
400000	warning condition
200000	factory use
100000	dirty window alert
080000	automatic gain control (AGC) failure
040000	supply voltage fault
020000	laser temperature control warning
010000	missing pulse
008000	door open
004000	blower/heater ON
002000	reboot
001000	configuration failure
000800	laser power low
000400	not currently used
000200	not currently used
000100	control board failure—configuration failure
000080	optical module board failure
000040	receiver board failure
000020	blower/heater fault
000010	optical module heater failure
000008	optical module temperature low
000004	laser temperature control (Peltier device) failure
000002	laser temperature low
000001	laser temperature high

Table 12. Ceilometer Status Codes

Model 8340 Ceilometer

When more than one error is detected, the errors are summed and the result is output in the status message. (For example, if the enclosure door was detected as being open (008000), the blower/heater ON was detected (004000), and a control board fault was detected (000100), the resulting sum would be 00C100 (C is the hexadecimal equivalent of 12). In this case, a failure condition would be present, so the full status message would be 80C100).

The status message will generally provide a good indication of the source of the fault. Bear in mind that not every warning or failure requires corrective action; some fault conditions will return to normal on their own.

One part of the self-test routine is the dirty window detector. Dirty window outputs must be evaluated with an awareness of current weather conditions, since precipitation will often trigger a dirty window alert.

Unit does not operate at all; no Status LED

1. Check to see that the circuit breaker switch is in the "on" position.
2. Check that the Ceilometer door is closed completely.
3. Open the Ceilometer door and measure the prime DC power at the power supply to ensure it is within specifications (12.5 V DC-13.8 V DC when on AC power).
4. Check the power supply fuses. When replacing fuses, use only those specified for the Ceilometer. Failure to use these exact types of fuses may result in permanent damage to the system.

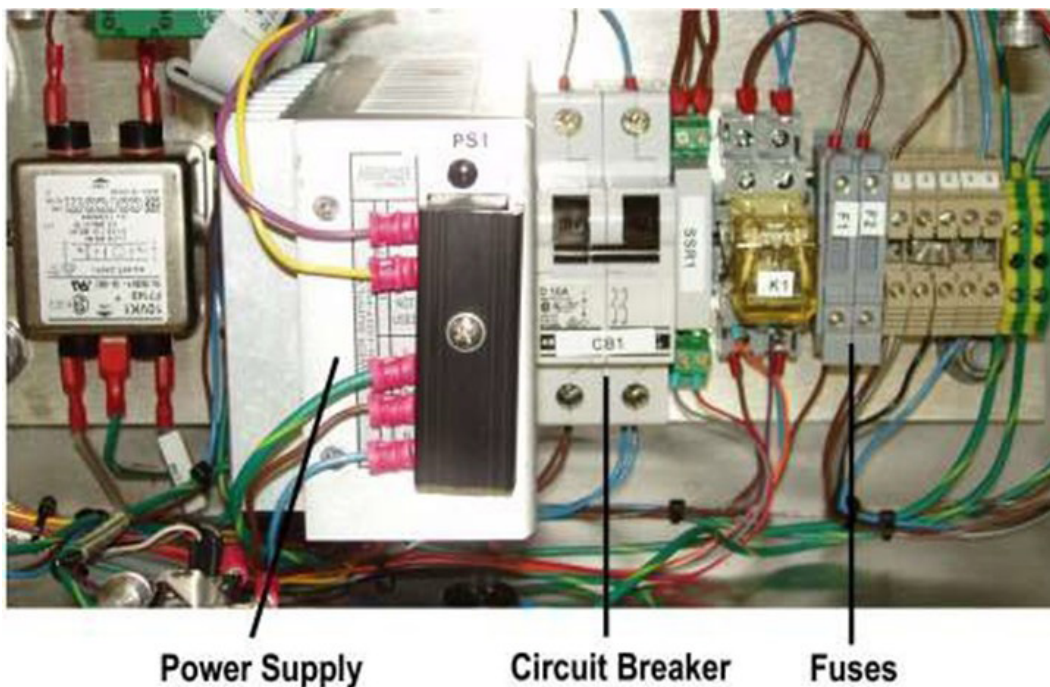

Figure 13. DIN Rail Components

Unit operates, no communication

Check the communication cable for continuity; check communication with an RS-232/RS-485 line monitor.

Module Faults

The optical module is, in general, the most likely candidate for change. The power supply is next likely, followed by the blower, and finally the Data Acquisition Board.

1. Check the LEDs on the Data Acquisition Board (see Figure 5). If the system is operating properly (the visible LEDs are illuminating and the voltages on the board all check out), but the Status LED on the Data Acquisition Board is not working, replace the Data Acquisition Board.
2. Check connections between modules (see Figure 14, Figure 15, Figure 16, and Figure 17). Remove connectors and reconnect them, then turn the system on again.
3. If both the optical module and Data Acquisition Board indicate failures, disconnect the optical module's three cables from the Data Acquisition Board to ensure it is not causing the Data Acquisition Board to fail (see Figure 14).

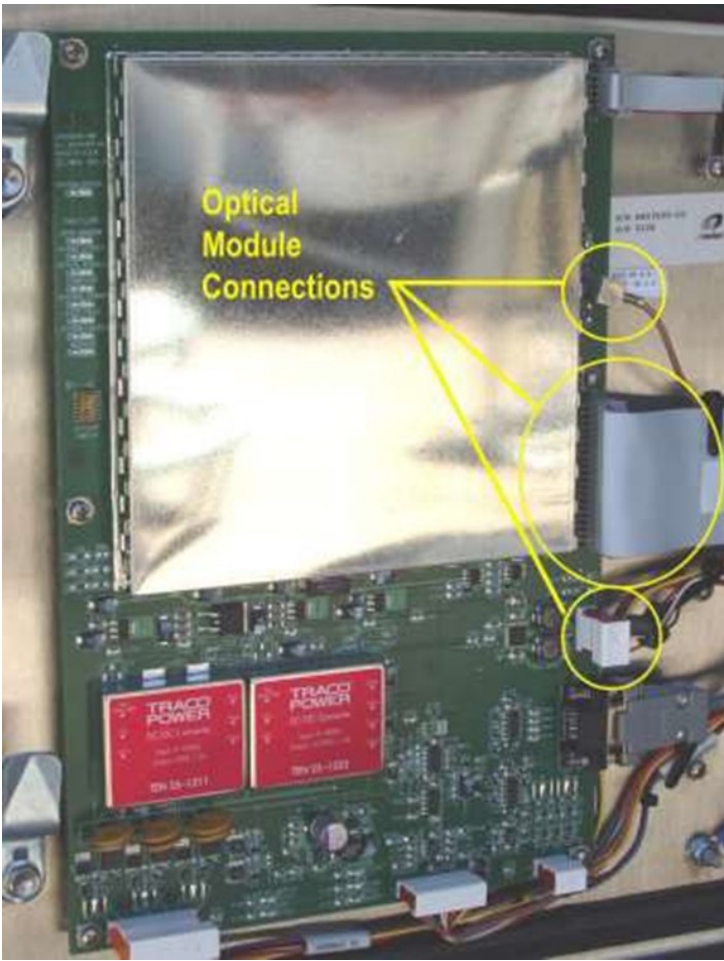

Figure 14. Optical Module Connections at the Data Acquisition Board

Self-testing is not always definitive. For instance, there may be a problem reading a temperature in the system, which could be caused by either the system A/D (on the Data Acquisition Board) or the temperature probe (in the optical module). In such cases, the best course is to exchange the most likely module first (generally the optical module).

8. Removal And Replacement

8.1 Removing Modules

IMPORTANT



Observe ESD grounding procedures when handling modules.

Do not change modules during weather events; never allow precipitation to enter the interior of the Ceilometer.

Whenever a module is being changed, the prime power should be shut off remotely. The only time the remote power switch should be on with the Ceilometer door open is when checking system operation during troubleshooting.

How to Open the Ceilometer

To gain access to the modules, open the Ceilometer door using a screwdriver to release the two latches.

8.1.1 Data Acquisition Board

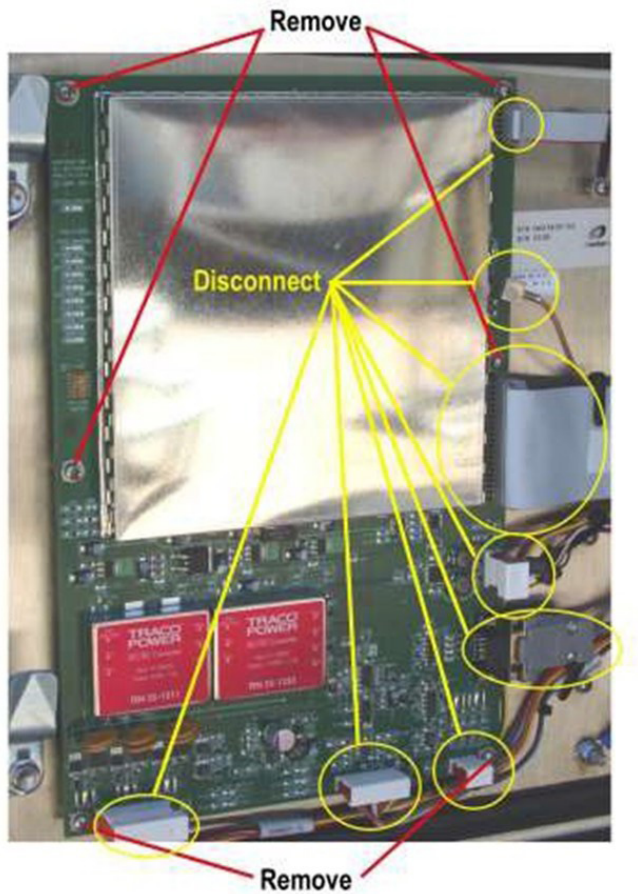
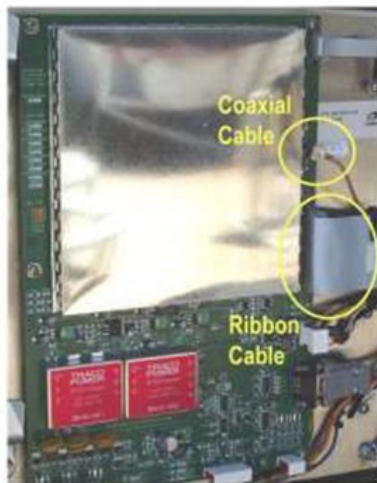

Figure 15. Data Acquisition Board Removal

1. The Data Acquisition Board is mounted to the Ceilometer door.
2. Disconnect eight cables from the Data Acquisition Board.
3. Remove the six screws at the corners and sides of the board.
4. Remove the Data Acquisition Board from the unit.

8.1.2 Optical Module



**Data
Acquisition
Board**

Figure 16. Optical Module Removal

1. Disconnect the ribbon cable and coaxial cable from the Data Acquisition Board.
2. Disconnect the heater cable and power supply cable from the Optical Module.
3. Remove the two screws securing the Optical Module to the enclosure.
4. Remove the two bolts securing the Optical Module to the enclosure.
5. Lift the module carefully up and out of the enclosure, paying particular attention to the Window Condition PCB mounted at the top of the Optical Module on the receiver side.

8.1.3 DIN Rail Components

The Power Supply and Circuit Breaker are installed on a DIN rail beneath the optical module.

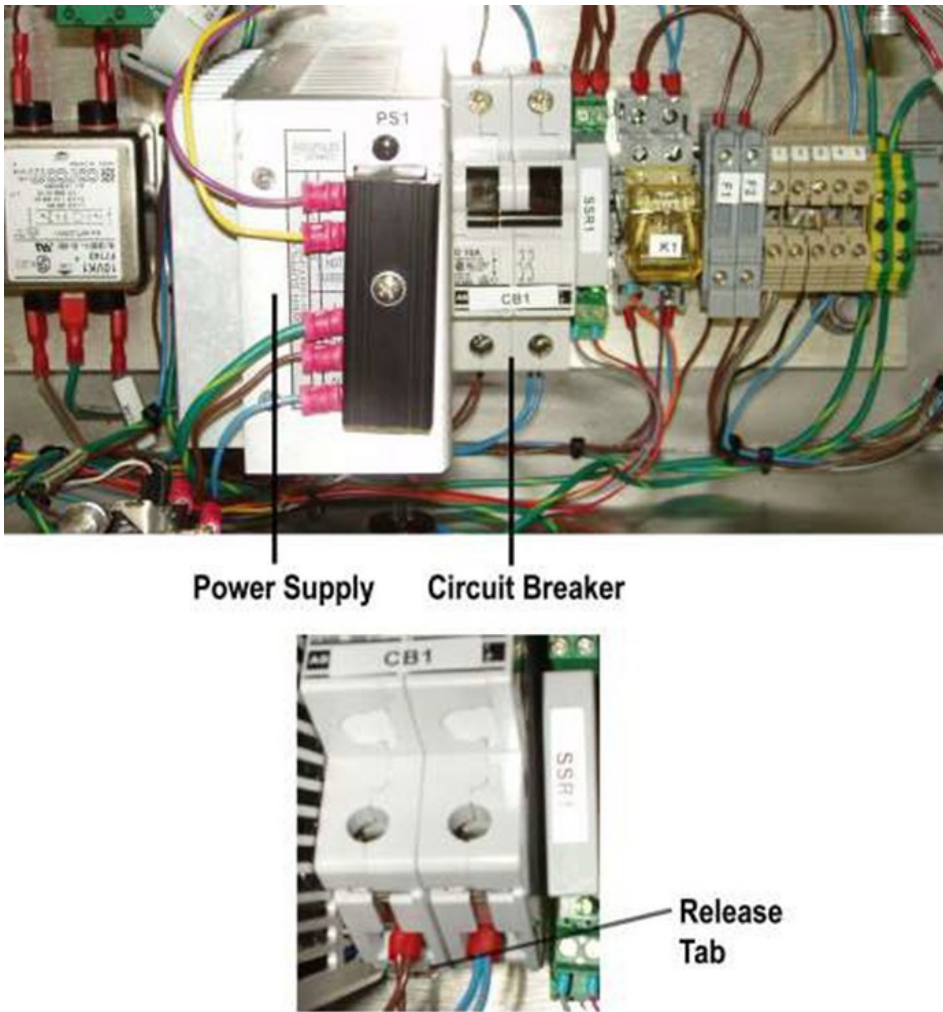

Figure 17. DIN Rail Component Removal

Power Supply

1. The four wires are connected to the Power Supply by removable connectors at the top and bottom of the Power Supply. Remove the top connector by pulling up until the connector pops free. Remove the bottom connector by pulling down until the connector pops free
2. Using a screwdriver, depress the tab at the bottom of the Power Supply.
3. While depressing the tab, grasp the Power Supply near the bottom and pull out to release the bottom DIN rail clip from the rail.
4. Slide the Power Supply up to remove it from the rail.

Circuit Breaker

1. Use a screwdriver to disconnect the four wires (two on the top and two on the bottom) from the Circuit Breaker.
2. Using a screwdriver, depress the tab at the bottom of the Circuit Breaker.
3. While depressing the tab, grasp the Circuit Breaker near the bottom and pull out to release the bottom DIN rail clip from the rail.
4. Slide the Circuit Breaker up to remove it from the rail.

8.2 Replacing Modules

IMPORTANT



Observe ESD grounding procedures when handling modules.

Do not change modules during weather events; never allow precipitation to enter the interior of the Ceilometer.

Whenever a module is being changed, the prime power should be shut off remotely. The only time the remote power switch should be on with the Ceilometer door open is when checking system operation during troubleshooting.

8.2.1 Data Acquisition Board (Figure 15)

1. Set the Data Acquisition Board in place, aligning the holes in the board with the standoffs in the enclosure door.
2. Install the six screws at the corners and sides of the board.
3. Connect the eight interconnecting cables disconnected during removal.

8.2.2 Optical Module (Figure 16)

1. Lower the Optical Module carefully into the enclosure. Be careful not to pinch the cables between the Optical Module and the housing structure.
2. Align the holes in the Optical Module's mounting plate with the matching holes on the enclosure mounting plate.
3. Install two bolts to secure the module in the enclosure.
4. Install two screws to secure the module in the enclosure.
5. Connect the heater cable and power supply cable to the Optical Module.
6. Connect the ribbon cable and coaxial cable to the Data Acquisition Board.

8.2.3 DIN Rail Components

The Power Supply and Circuit Breaker are installed on a DIN rail beneath the optical module. Follow the steps below to replace either component.

1. With the bottom of the component angled slightly out, hook the top DIN rail clip onto the DIN rail.
2. Lower the bottom of the component onto the DIN rail and press until the lower DIN rail clip snaps into place.
3. Connect the wires as indicated in the wiring diagram.

Power Supply

1. With the bottom of the Power Supply angled slightly out, hook the top DIN rail clip onto the DIN rail.
2. Lower the bottom of the Power Supply onto the DIN rail and press until the lower DIN rail clip snaps into place.
3. Connect the five-terminal snap-on connectors to the top connector on the Power Supply.
4. Connect the three-terminal snap-on connectors to the bottom connector on the Power Supply.

Circuit Breaker

1. With the bottom of the Circuit Breaker angled slightly out, hook the top DIN rail clip onto the DIN rail.
2. Lower the bottom of the Circuit Breaker onto the DIN rail and press until the lower DIN rail clip snaps into place.
3. Connect the wires disconnected during module removal to the screw terminals on the Circuit Breaker and tighten. Refer to the wiring diagram (M403435-04-019) as needed.

9. Firmware Updates

The *Ceilometer Firmware Update Tool User's Manual* (M595167-00-001) describes the tools and procedures for updating the Model 8340 Ceilometer firmware.

10. Specifications

Parameter	Specification	
	8340-F	8340-G
Measurement Range	to 40,000 ft	
Resolution	12.5 ft	
Accuracy	±20 ft. over full range	
Cloud Layers	up to four, base and depth	
Measurement Cycle	Configurable to 30-, 60-, or 120-second sampling/ reporting interval; can be set to switch automatically to 180-second interval when no clouds are detected	
Principle of Operation		
LIDAR	Pulsed InGaAs diode	
Wavelength	905 nm ± 10 nm	
Pulse Width	50 ns	
Collector	Si avalanche photodiode, variable gain, temperature- compensated	
Optics	Side-by-side optical channels	
Safety		
Laser Safety	FDA Class I, 21 CFR 1040 (EN 60825-1)	
Electrical		
Supply Voltage	100–120 V AC 47–64 Hz, 100 W	200–240 V AC 47–64 Hz, 100 W
Power Consumption with Optional Heater/Blower	600 W	
Operating Temperature	-40 to +60°C (-40 to +140°F)	
Storage Temperature	-50 to +70°C (-58 to +158°F)	
Humidity	0–100% (noncondensing)	
Serial Output	RS-232 (3-wire) or RS-485 (half duplex)	
Serial Output Baud Rate	300, 1200, 4800, or 9600 bps	
Serial Port Parameter Setting	8-N-1 (8 data bits, no parity, 1 stop bit)	
Serial Connector	Conxall® Mini-Con-X® 7280-5SG-300 Field Connector	
Battery Backup	Ceilometer electronics only, built-in charger	

Model 8340 Ceilometer

Parameter		Specification	
		8340-F	8340-G
Mechanical			
Mounting		Unistrut mounted on single- leg pedestal; 2½" pipe	
Enclosure	Ceilometer	NEMA 4X electro-polished 304 stainless steel	
	Optional Heater/Blower	Aluminum	
Dimensions	Ceilometer	19" H × 16" W × 9" D (48 cm × 41 cm × 23 cm)	
	With Optional Heater/Blower	27" H × 20" W × 16" D (67 cm × 51 cm × 41 cm)	
Weight	Ceilometer	19.5 kg (43 lb)	
	Optional Heater/Blower	5.5 kg (12 lb)	
Shipping Weight	Ceilometer	27.3 kg (60 lb)	
	Optional Heater/Blower	8 kg (18 lb)	

11. Warranty

Unless specified otherwise, ADB Safegate (the Company) warrants its products to be free from defects in material and workmanship under normal use and service for one year from date of shipment, subject to the following conditions:

- a. The obligation of the Company under this warranty is limited to repairing or replacing items or parts which have been returned to the Company and which upon examination are disclosed, to the Company's satisfaction, to have been defective in material or workmanship at time of manufacture.
- b. The claimant shall pay the cost of shipping any part or instrument to the Company. If the Company determines the part to be defective in material or workmanship, the Company shall prepay the cost of shipping the repaired instrument to the claimant. Under no circumstances will the Company reimburse claimant for cost incurred in removing and/or reinstalling replacement parts.
- c. This warranty shall not apply to any Company products which have been subjected to misuse, negligence or accident.
- d. This warranty and the Company's obligation thereunder is in lieu of all other warranties, express or implied, including warranties of merchantability and fitness for a particular purpose, consequential damages and all other obligations or liabilities.

No other person or organization is authorized to give any other warranty or to assume any additional obligation on the Company's behalf, unless made in writing and signed by an authorized officer of the Company.

12. Drawings

The following pages contain drawings to help in the installation, use, and maintenance of this instrument.

Schematics	
8340-F-019	8340-F Top Level Wiring Diagram
8340-G-019	8340-G Top Level Wiring Diagram
M403437-04-019	Heater/Blower Wiring Diagram (100–120 V AC) M403438-04-019
M403438-04-019	Heater/Blower Wiring Diagram (200–240 V AC) M403434-01-019
M403434-01-019	Optical Module Wiring Diagram
M403435-04-019	Enclosure Wiring Diagram
Installation Drawings	
M488261-00-007	Ceilometer Installation Drawing
83406-00-007	Heater/Blower Installation Drawing (100–120 V)
83407-00-007	Heater/Blower Installation Drawing (200–240 V)
—	Ceilometer Site Preparation

REVISIONS				DWG NO. 8340-F-019	
REV	ECN	DESCRIPTION	DATE	APPROVED	
A	0600	INITIAL RELEASE	12-06-05	SLVS	
B	1245	"M491749-01 OR M491763-01" WAS: M491749-00	9-19-07	PMK	
C	4499	ADDED DOMESTIC POWER WIRE COLORS	05-25-16	JPATTERSON	

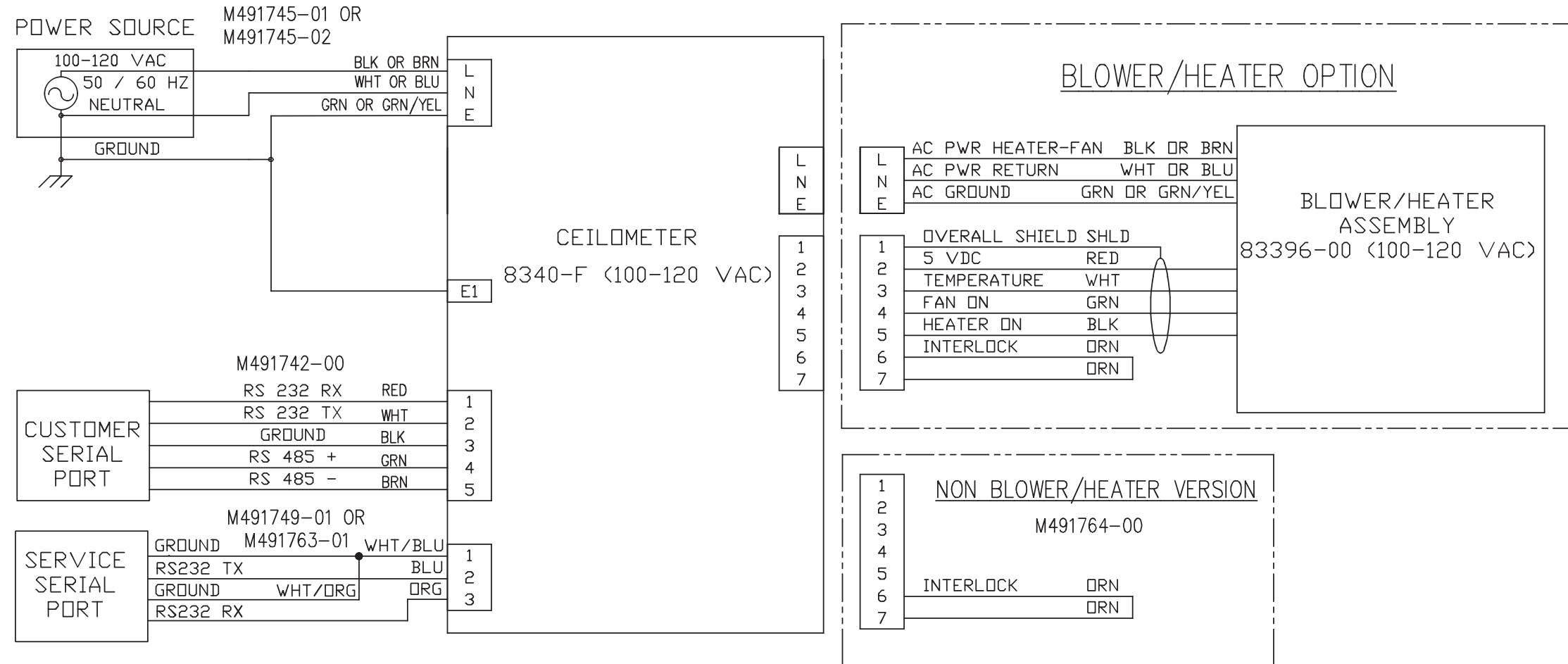

EXCEPT AS MAY OTHERWISE BE SPECIFIED BY CONTRACT, THIS DOCUMENT AND THE DATA DISCLOSED HEREIN AND HEREWITH, IS NOT TO BE USED, REPRODUCED OR DISCLOSED, IN WHOLE OR IN PART, TO ANYONE WITHOUT THE WRITTEN PERMISSION OF ADB SAFEGATE..

APPEND THE FOLLOWING DOCUMENTS WHEN CHANGING THIS DOCUMENT:	UNLESS OTHERWISE SPECIFIED: DIMENSIONS ARE IN INCHES TOLERANCES .XX=±.010 ANGLES ±1/2" .XXX=±.005 CONCENTRICITY: .003 TIR DO NOT SCALE DRAWING	DRAWN BY: J.CONNER 12-06-05	TITLE WIRING DIAGRAM, CEILOMETER ASSY, 8340-F, TOP LEVEL	ADB SAFEGATE
	MATL	REVISD BY: JPATTERSON 05-25-16		
	FINISH	CHECKED BY: SLVS 12-06-05		
	TREATMENT	DESIGN ENGINEER: SLVS 12-06-05	SIZE C	DWG NO. 8340-F-019
		PROJECT MANAGER:	SCALE NONE	RELEASE DATE
		APPROVALS	DATE	SHEET 1 OF 1

REVISIONS			DWG NO. 8340-G-019	
REV	ECN	DESCRIPTION	DATE	APPROVED
A	0600	INITIAL RELEASE	12-06-05	SLVS
B	1245	"M491749-01 OR M491763-01" WAS: M491749-00	9-19-07	PMK
C	4499	ADDED DOMESTIC POWER WIRE COLORS	05-25-16	JPATTERSON

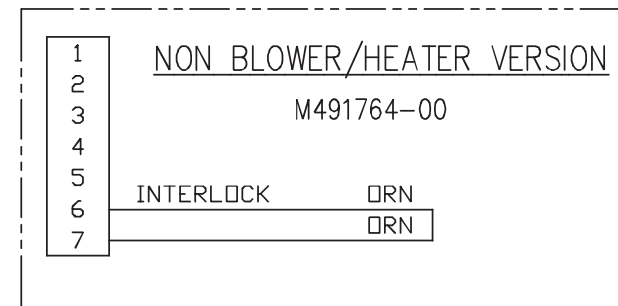
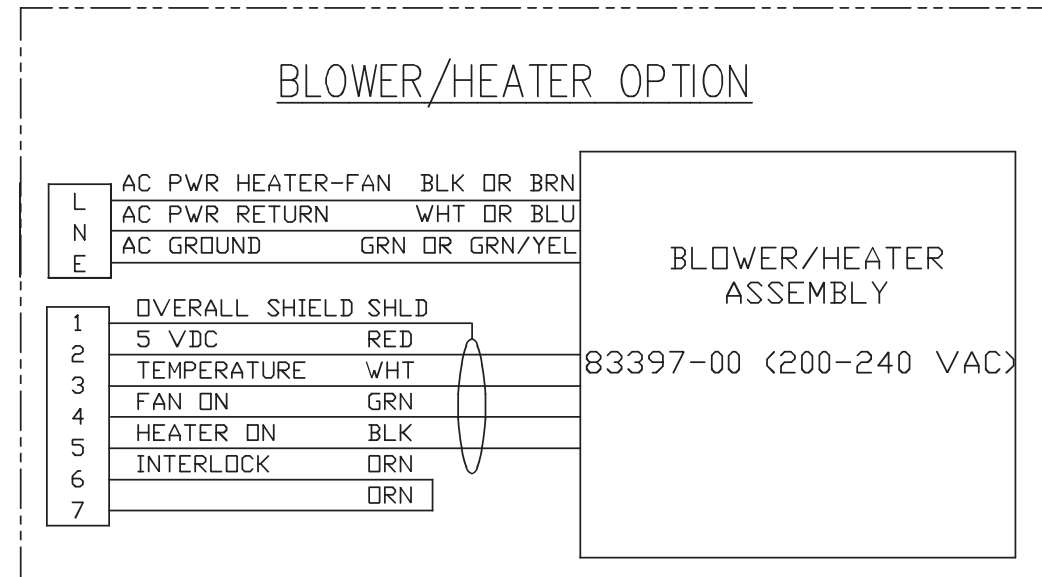
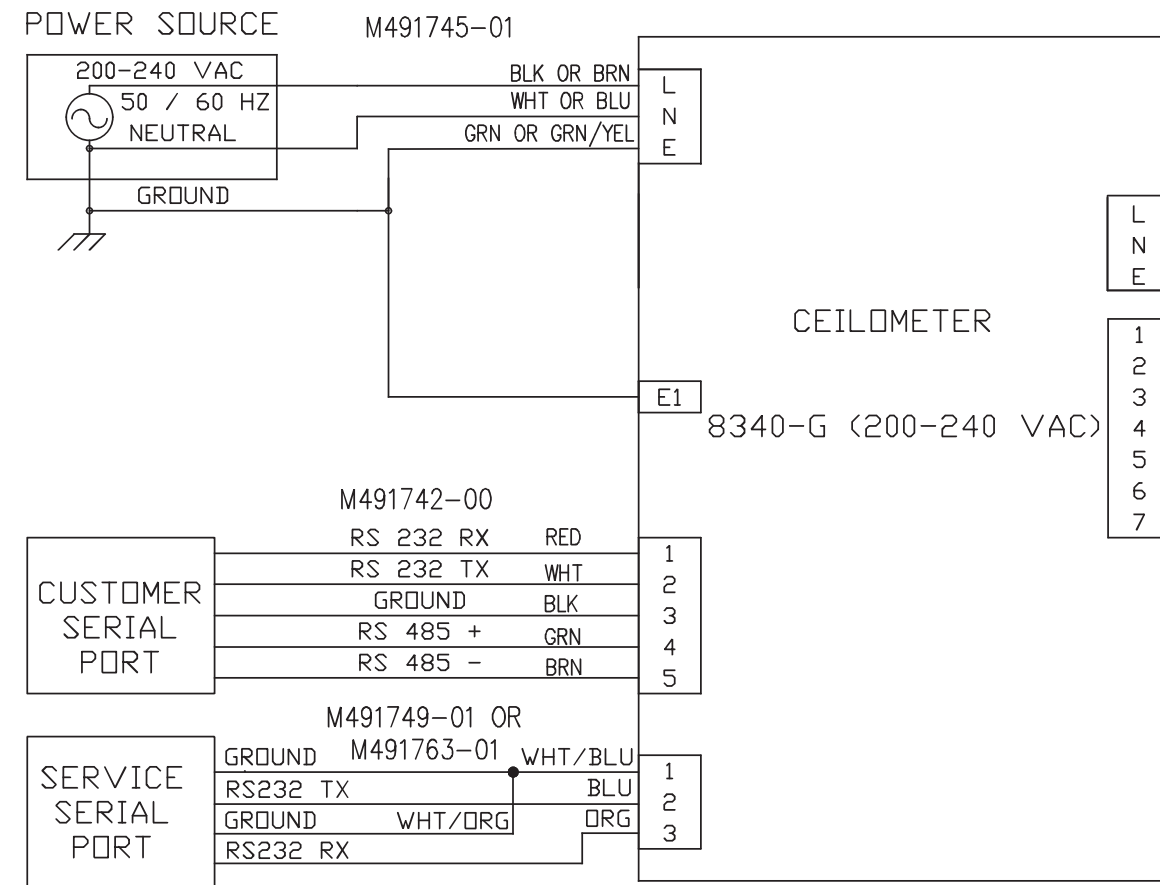

EXCEPT AS MAY OTHERWISE BE SPECIFIED BY CONTRACT, THIS DOCUMENT AND THE DATA DISCLOSED HEREIN AND HEREWITH, IS NOT TO BE USED, REPRODUCED OR DISCLOSED, IN WHOLE OR IN PART, TO ANYONE WITHOUT THE WRITTEN PERMISSION OF ADB SAFEGATE..

APPEND THE FOLLOWING DOCUMENTS WHEN CHANGING THIS DOCUMENT:	UNLESS OTHERWISE SPECIFIED: DIMENSIONS ARE IN INCHES TOLERANCES .XX=±.010 ANGLES ±1/2' .XXX=±.005 CONCENTRICITY: .003 TIR DO NOT SCALE DRAWING	DRAWN BY: J.CONNER	12-06-05	TITLE WIRING DIAGRAM, CEILOMETER ASSY, 8340-G, TOP LEVEL	ADB SAFEGATE
		REVISED BY: JPATTERSON	05-25-16		
		CHECKED BY: SLVS	12-06-05		
		DESIGN ENGINEER: SLVS	12-06-05		
MATL		PROJECT MANAGER:		SIZE C	DWG NO. 8340-G-019
FINISH		APPROVALS	DATE	SCALE NONE	RELEASE DATE
TREATMENT					SHEET 1 OF 1

REVISIONS			DWG NO. M403437-04-019	
REV	ECO	DESCRIPTION	DATE	APPROVED
A	1317	INITIAL RELEASE	11-15-07	PMK
B	4499	ADD DOMESTIC POWER WIRE COLORS	05-24-16	JPATTERSON

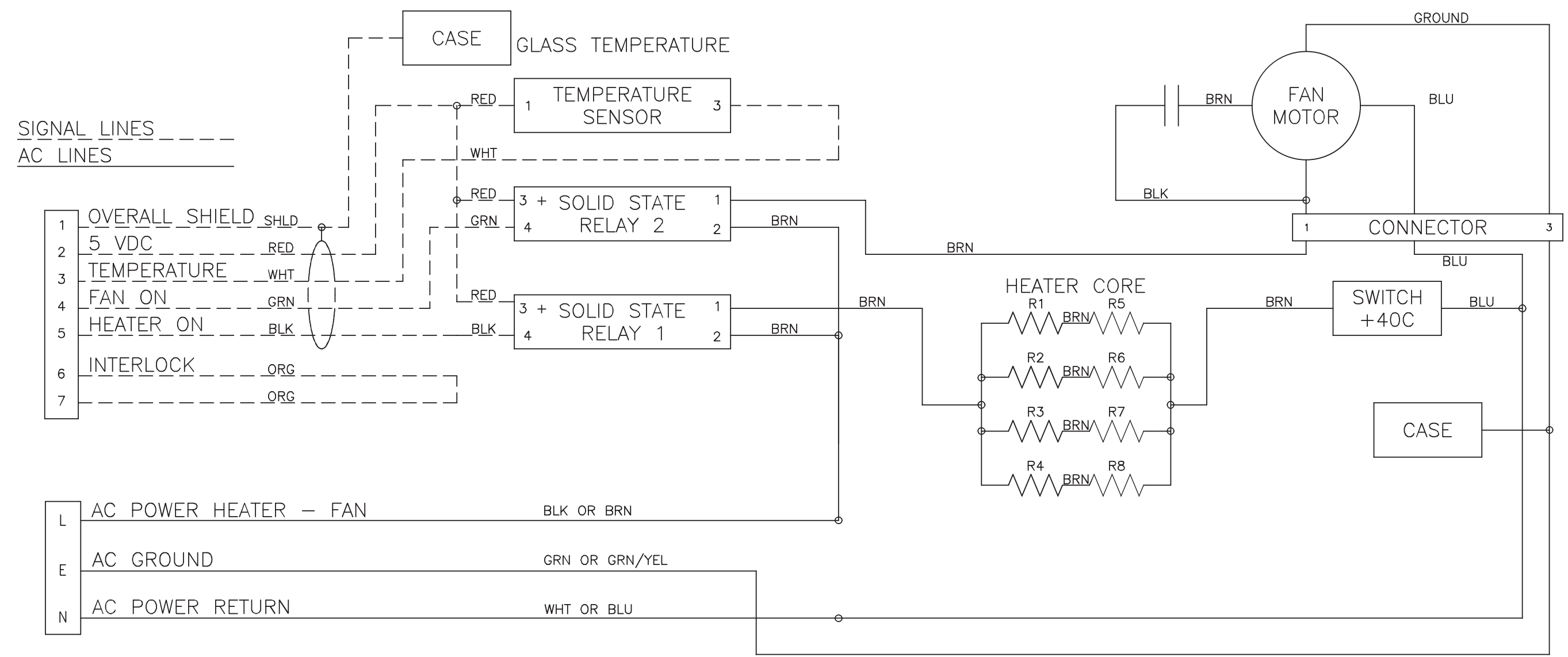

EXCEPT AS MAY OTHERWISE BE SPECIFIED BY CONTRACT, THIS DOCUMENT AND THE DATA DISCLOSED HEREIN AND HERewith, IS NOT TO BE USED, REPRODUCED OR DISCLOSED, IN WHOLE OR IN PART, TO ANYONE WITHOUT THE WRITTEN PERMISSION OF ADB SAFEGATE.

APPEND THE FOLLOWING DOCUMENTS WHEN CHANGING THIS DOCUMENT:	UNLESS OTHERWISE SPECIFIED: DIMENSIONS ARE IN INCHES TOLERANCES XX=±.010 ANGLES ±1/2' XXX=±.005 CONCENTRICITY: .003 TIR DO NOT SCALE DRAWING	DRAWN BY: P KOOYMAN 11-15-07	TITLE WIRING DIAGRAM, HEATER/BLOWER, 100-120 VAC, CEIL, CE	ADB SAFEGATE
	MATL NONE	REVISED BY: J PATTERSON 05-24-16		
	FINISH NONE	CHECKED BY: J CONNER 11-15-07		
	TREATMENT	DESIGN ENGINEER: J CONNER 11-15-07		
		PROJECT MANAGER: B PERRIN 11-15-07	SIZE D	DWG NO. M403437-04-019
		APPROVALS	DATE	SCALE NONE
			RELEASE DATE	SHEET 1 OF 1

REVISIONS				DWG NO. M403438-04-019	
REV	ECO	DESCRIPTION	DATE	APPROVED	
A	1317	INITIAL RELEASE	11-15-07	PMK	
B	1477	CHANGED RESISTOR WIRING FOR 230 VAC	4/4/08	BRG	
C	4499	ADDED DOMESTIC POWER WIRE COLORS	05-24-16	JPATTERSON	

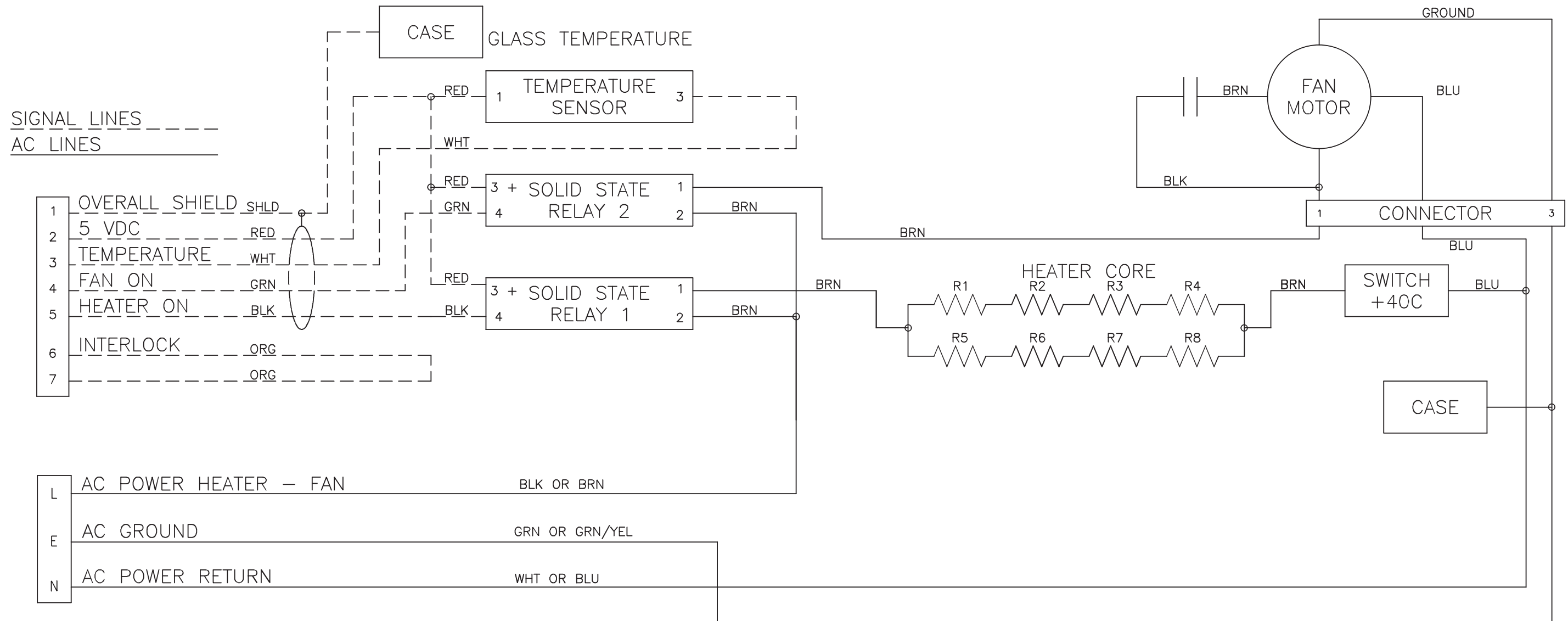

EXCEPT AS MAY OTHERWISE BE SPECIFIED BY CONTRACT, THIS DOCUMENT AND THE DATA DISCLOSED HEREIN AND HEREWITH, IS NOT TO BE USED, REPRODUCED OR DISCLOSED, IN WHOLE OR IN PART, TO ANYONE WITHOUT THE WRITTEN PERMISSION OF ADB SAFEGATE..

APPEND THE FOLLOWING DOCUMENTS WHEN CHANGING THIS DOCUMENT:	UNLESS OTHERWISE SPECIFIED: DIMENSIONS ARE IN INCHES	DRAWN BY: P KOOYMAN	11-15-07	TITLE WIRING DIAGRAM, HEATER/BLOWER, 200-240 VAC, CEIL, CE	ADB SAFEGATE
	TOLERANCES XX=±.010 ANGLES ±1/2' XXX=±.005 CONCENTRICITY: .003 TIR DO NOT SCALE DRAWING	REVISED BY: J PATTERSON	05-24-16		
	MATL NONE	CHECKED BY: J CONNER	11-15-07		
	FINISH NONE	DESIGN ENGINEER: J CONNER	11-15-07		
TREATMENT	PROJECT MANAGER: B PERRIN	11-15-07	11-15-07	SIZE D	DWG NO. M403438-04-019
	APPROVALS	DATE	SCALE NONE	RELEASE DATE	SHEET 1 OF 1

REV		ECO	DESCRIPTION	DATE	APPROVED
A	0598		INITIAL RELEASE	10/13/05	SLVS
B	0806		CHANGED M404850-00 TO M404850-01	6/12/06	BRG

THESE THREE CABLES ARE SHOWN FOR INFORMATION ONLY AND ARE NOT PART OF ASSY M403434-01.

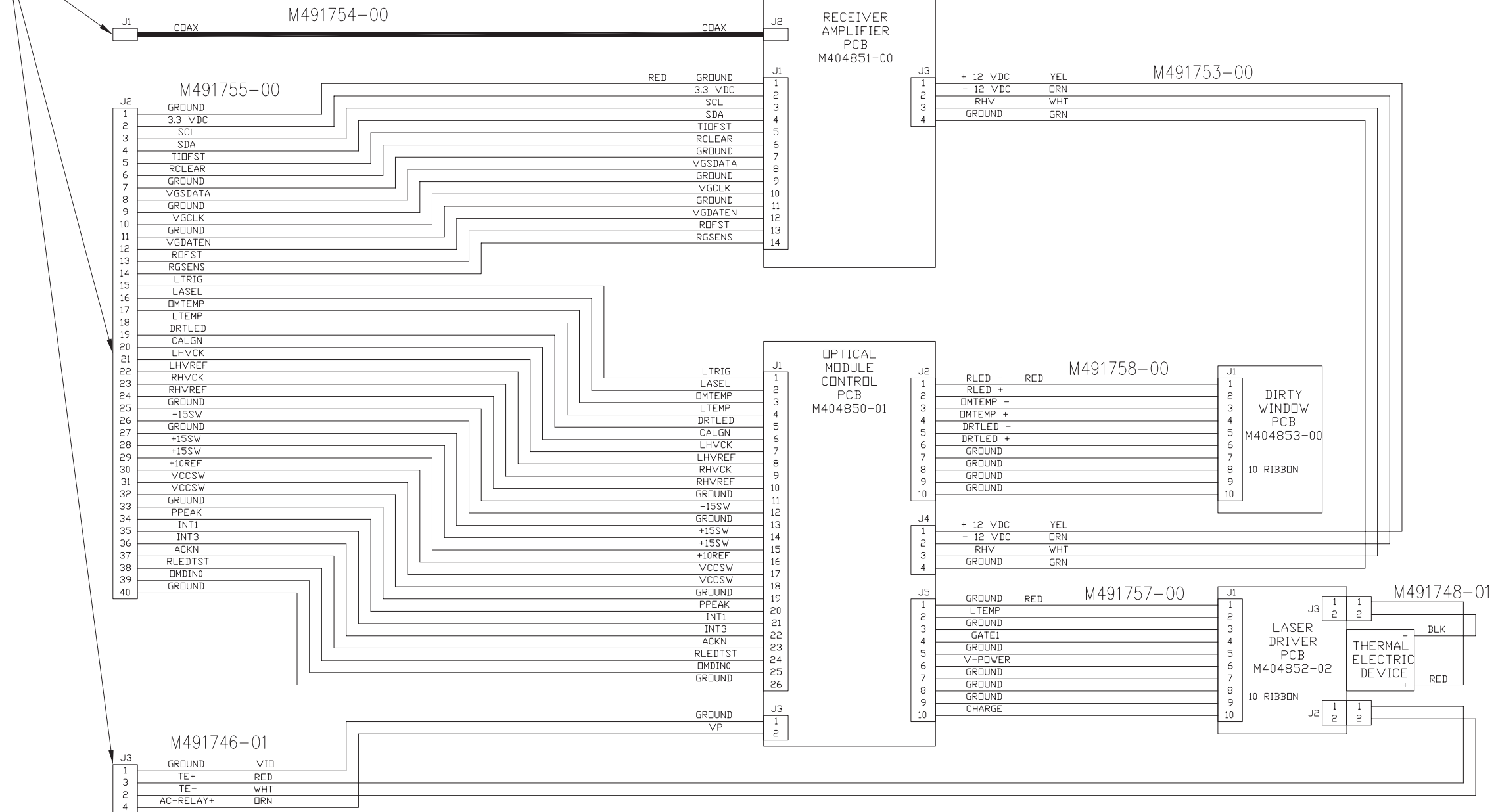

EXCEPT AS MAY OTHERWISE BE SPECIFIED BY CONTRACT, THIS DOCUMENT AND THE DATA DISCLOSED HEREIN AND HERewith, IS NOT TO BE USED, REPRODUCED OR DISCLOSED, IN WHOLE OR IN PART, TO ANYONE WITHOUT THE WRITTEN PERMISSION OF ADB SAFEGATE..

APPEND THE FOLLOWING DOCUMENTS WHEN CHANGING THIS DOCUMENT:		UNLESS OTHERWISE SPECIFIED: DIMENSIONS ARE IN INCHES		DRAWN BY: J.CONNER		TITLE: WIRING DIAGRAM OPTICAL MODULE ASSEMBLY, 8340 CEILOMETER		ADB SAFEGATE
		TOLERANCES .XX=±.010 ANGLES ±1/2" .XXX=±.005 CONCENTRICITY: .003 TIR DO NOT SCALE DRAWING		6-22-04				
		MATL		REVISED BY: BRG		10/19/04		
		FINISH		CHECKED BY:				
		TREATMENT		DESIGN ENGINEER: SLVS		5-13-04		
				PROJECT MANAGER:				
				APPROVALS		DATE		
				SCALE: NONE		RELEASE DATE		
				SIZE: C		DWG NO. M403434-01-019		
						SHEET 1 OF 1		

REV		ECN	DESCRIPTION	DATE	APPROVED
A	0600		INITIAL RELEASE	12-05-05	PK
B	0895		ADDED NOTE	12-05-06	PK
C	1245		"M491750-01" WAS: M491750-00	9-20-07	PMK
D	1317		"M403437-04" WAS: M403437-01, "M403438-04" WAS: M403438-01	11-27-07	PMK

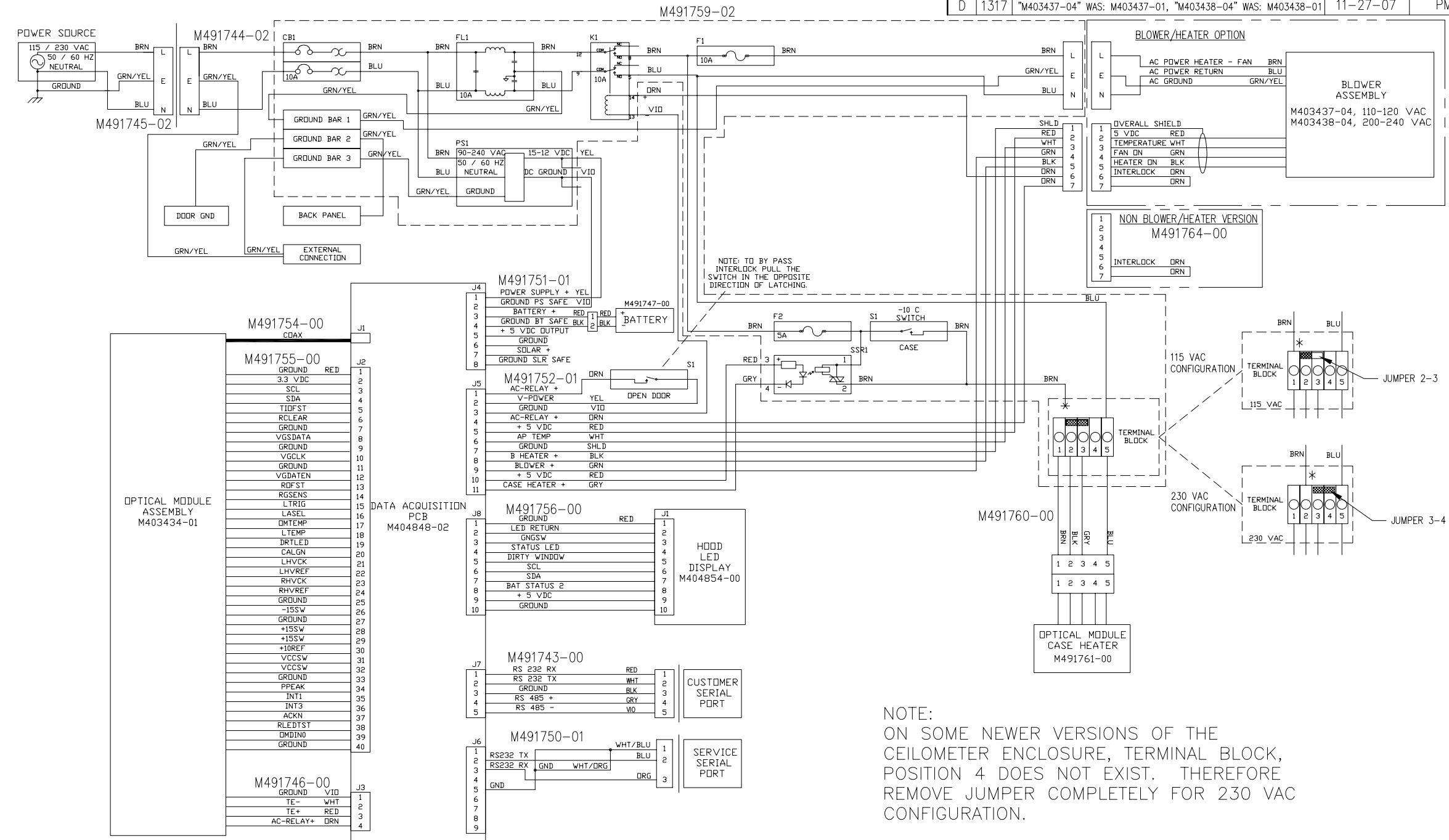

EXCEPT AS MAY OTHERWISE BE SPECIFIED BY CONTRACT, THIS DOCUMENT AND THE DATA DISCLOSED HEREIN AND HERewith, IS NOT TO BE USED, REPRODUCED OR DISCLOSED, IN WHOLE OR IN PART, TO ANYONE WITHOUT THE WRITTEN PERMISSION OF ADB SAFEGATE..

APPEND THE FOLLOWING DOCUMENTS WHEN CHANGING THIS DOCUMENT:		UNLESS OTHERWISE SPECIFIED: DIMENSIONS ARE IN INCHES TOLERANCES .XX=±.010 ANGLES ±1/2' .XXX=±.005 CONCENTRICITY: .003 TIR DO NOT SCALE DRAWING		DRAWN BY: P KOOYMAN 12-05-05		TITLE WIRING DIAGRAM, CEIL ENCLOSURE, 115 & 230 VAC HP		ADB SAFEGATE
		M491751-01		REVISED BY: PMK 12-05-06		SIZE C		
		M491752-01		CHECKED BY: SLVS 12-05-05		DWG NO. M403435-04-019		
		M491756-00		DESIGN ENGINEER: SLVS 12-05-05		SCALE NONE		
		M491743-00		PROJECT MANAGER:		RELEASE DATE		
		M491750-01		APPROVALS		SHEET 1 OF 1		

REV		ECO	DESCRIPTION	DATE	APPROVED
A	0545		INITIAL RELEASE	7-5-05	J.CONNER
B	1778		ADDED 2 1/2" PIPE INFO	2-3-09	J.CONNER

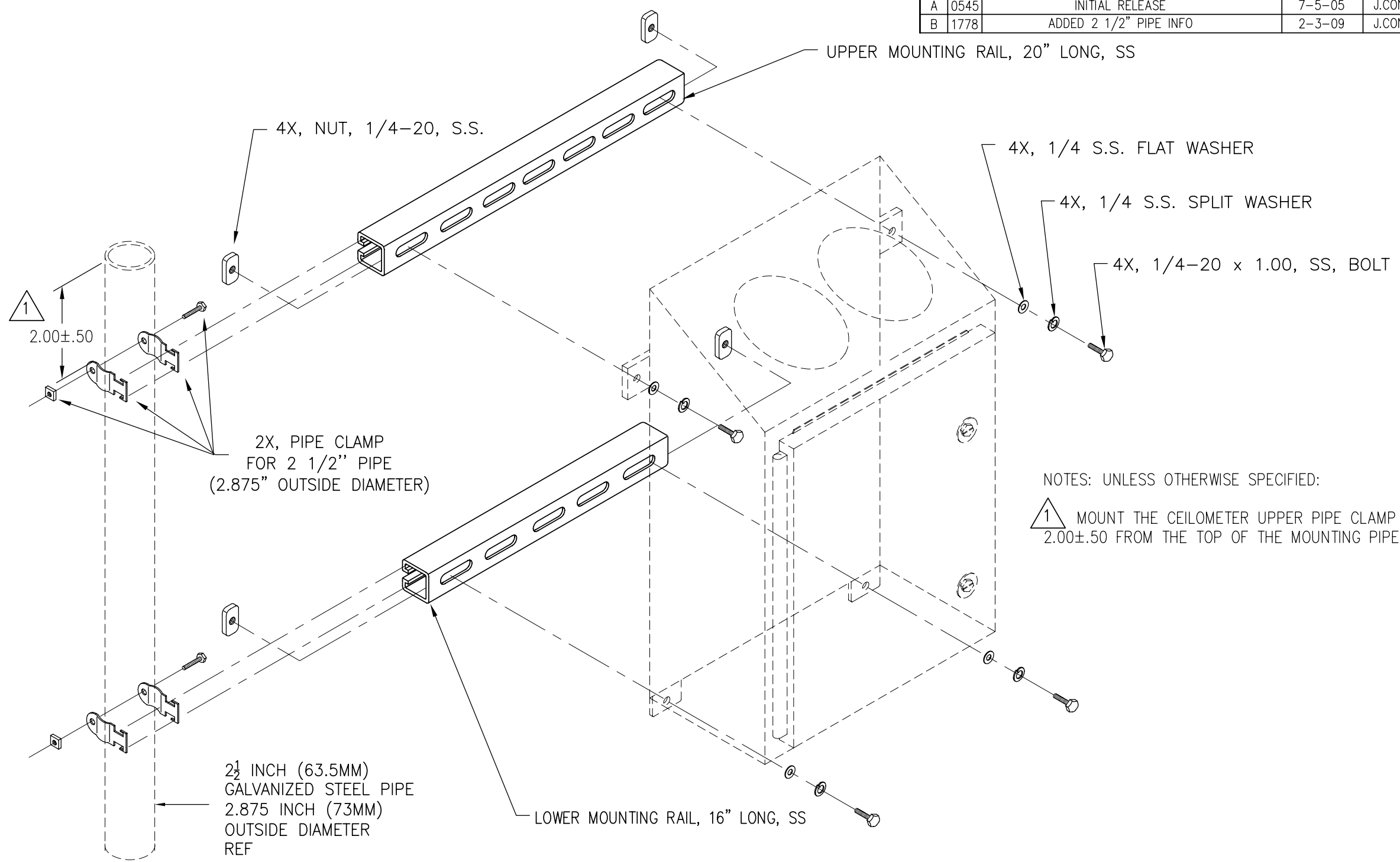

NOTES: UNLESS OTHERWISE SPECIFIED:
 1 MOUNT THE CEILOMETER UPPER PIPE CLAMP 2.00±.50 FROM THE TOP OF THE MOUNTING PIPE.

EXCEPT AS MAY OTHERWISE BE SPECIFIED BY CONTRACT, THIS DOCUMENT AND THE DATA DISCLOSED HEREIN AND HEREWITH, IS NOT TO BE USED, REPRODUCED OR DISCLOSED, IN WHOLE OR IN PART, TO ANYONE WITHOUT THE WRITTEN PERMISSION OF ADB SAFEGATE..

APPEND THE FOLLOWING DOCUMENTS WHEN CHANGING THIS DOCUMENT:	UNLESS OTHERWISE SPECIFIED: DIMENSIONS ARE IN INCHES	DRAWN BY:	J.CONNER	7-5-05	TITLE INSTALLATION DWG, MOUNTING KIT, STAINLESS STEEL, 8339 CEILOMETER	ADB SAFEGATE	
	TOLERANCES .XX=±.010 ANGLES ±1/2° .XXX=±.005 CONCENTRICITY: .003 TIR DO NOT SCALE DRAWING	REVISED BY:					
	MATL AS ISSUED	CHECKED BY:					
	FINISH AS ISSUED	DESIGN ENGINEER:					
TREATMENT NONE	PROJECT MANAGER:				SIZE C	DWG NO. M488261-00-007	
	APPROVALS	DATE			SCALE NONE	RELEASE DATE	SHEET 1 OF 1

REVISIONS			DWG NO. 83396-00-007	
REV	ECO	DESCRIPTION	DATE	APPROVED
A	1317	INITIAL RELEASE	11-27-07	PMK
B	1778	ADDED 2 1/2" PIPE INFO	2-3-09	J.CONNER

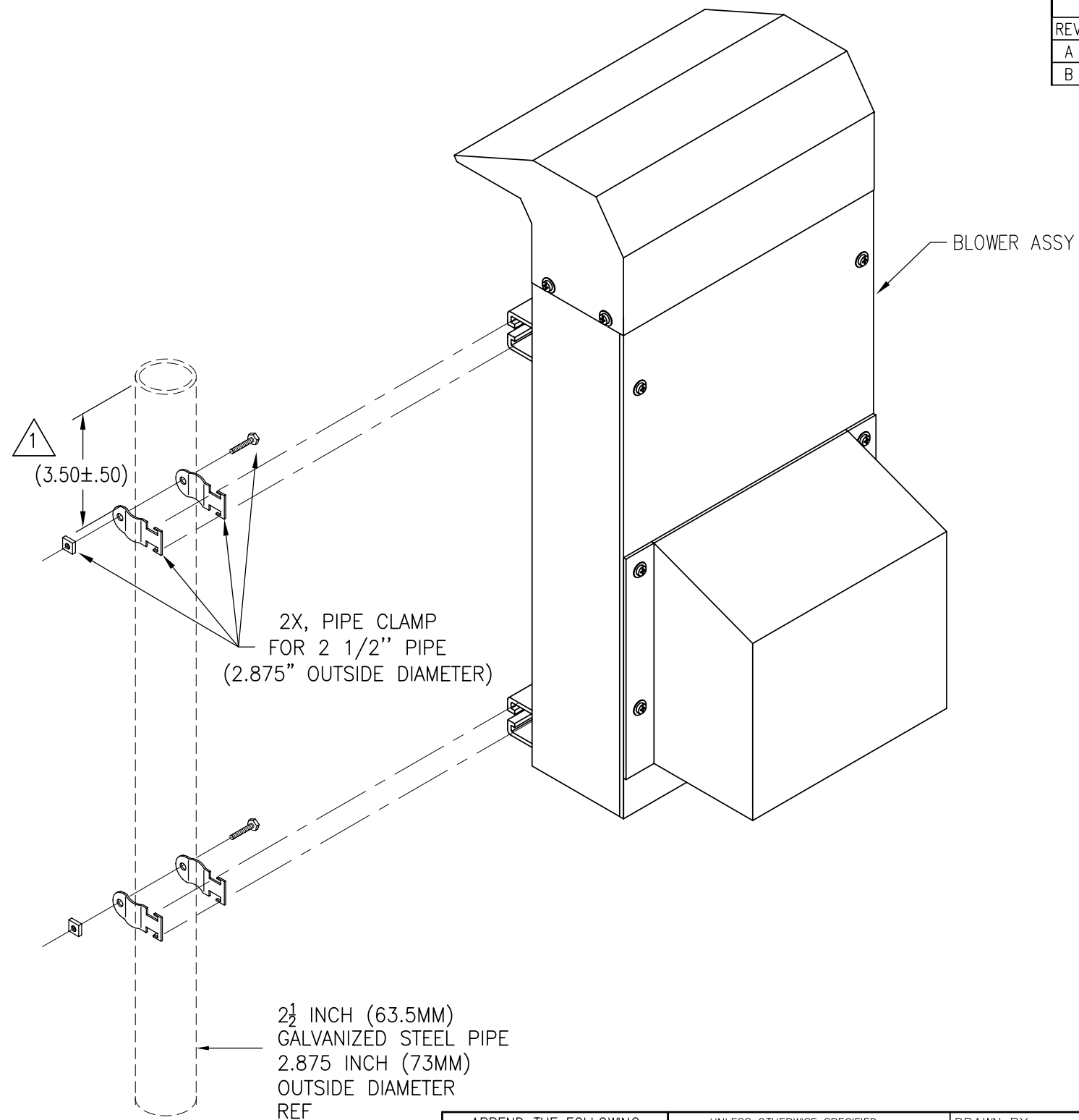

NOTES: UNLESS OTHERWISE SPECIFIED:

1 MOUNT THE BLOWER UPPER PIPE CLAMP JUST BELOW THE CEILOMETER UPPER PIPE CLAMP (AT APPROXIMATELY 3.50" FROM THE TOP OF THE MOUNTING PIPE) AND THE BLOWER LOWER PIPE CLAMP JUST ABOVE THE CEILOMETER LOWER PIPE CLAMP.

EXCEPT AS MAY OTHERWISE BE SPECIFIED BY CONTRACT, THIS DOCUMENT AND THE DATA DISCLOSED HEREIN AND HEREWITH, IS NOT TO BE USED, REPRODUCED OR DISCLOSED, IN WHOLE OR IN PART, TO ANYONE WITHOUT THE WRITTEN PERMISSION OF ADB SAFEGATE..

APPEND THE FOLLOWING DOCUMENTS WHEN CHANGING THIS DOCUMENT:	UNLESS OTHERWISE SPECIFIED: DIMENSIONS ARE IN INCHES TOLERANCES .XX=±.010 ANGLES ±1/2' .XXX=±.005 CONCENTRICITY: .003 TIR DO NOT SCALE DRAWING	DRAWN BY: PMK	11-27-07	TITLE INSTALLATION DWG, MOUNTING, BLOWER, SS, 8339 CEILOMETER	ADB SAFEGATE	
	MATL AS ISSUED	CHECKED BY: J CONNER	11-27-07			
	FINISH AS ISSUED	DESIGN ENGINEER: J CONNER	11-27-07	PROJECT MANAGER:	SIZE C	DWG NO. 83396-00-007
	TREATMENT NONE	APPROVALS	DATE	SCALE NONE	RELEASE DATE	SHEET 1 OF 1

REVISIONS			DWG NO. 83397-00-007	
REV	ECO	DESCRIPTION	DATE	APPROVED
A	1317	INITIAL RELEASE	11-27-07	PMK
B	1778	ADDED 2 1/2" PIPE INFO	2-3-09	J.CONNER

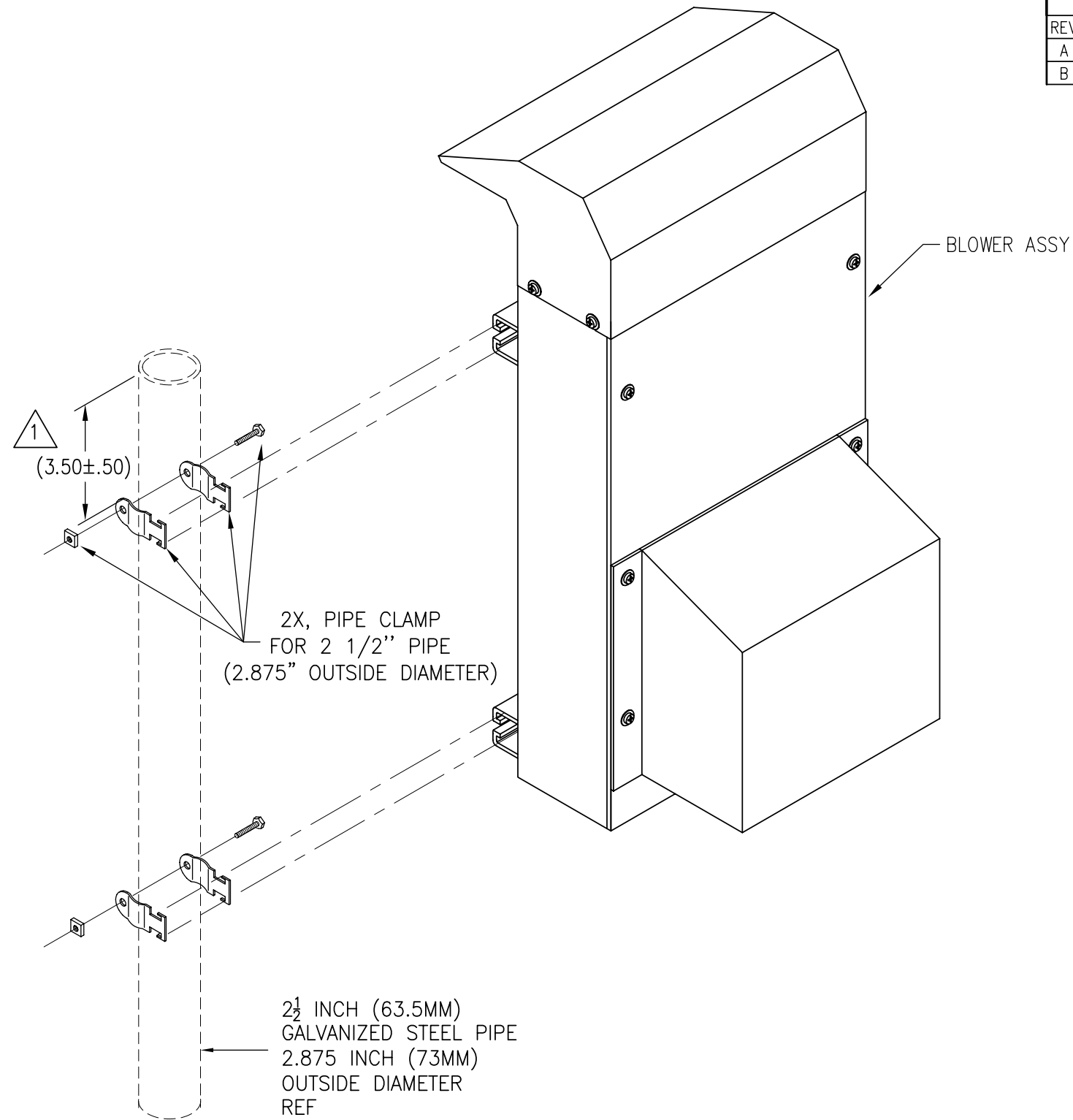

NOTES: UNLESS OTHERWISE SPECIFIED:

1 MOUNT THE BLOWER UPPER PIPE CLAMP JUST BELOW THE CEILOMETER UPPER PIPE CLAMP (AT APPROXIMATELY 3.50" FROM THE TOP OF THE MOUNTING PIPE) AND THE BLOWER LOWER PIPE CLAMP JUST ABOVE THE CEILOMETER LOWER PIPE CLAMP.

EXCEPT AS MAY OTHERWISE BE SPECIFIED BY CONTRACT, THIS DOCUMENT AND THE DATA DISCLOSED HEREIN AND HERewith, IS NOT TO BE USED, REPRODUCED OR DISCLOSED, IN WHOLE OR IN PART, TO ANYONE WITHOUT THE WRITTEN PERMISSION OF ADB SAFEGATE..

APPEND THE FOLLOWING DOCUMENTS WHEN CHANGING THIS DOCUMENT:	UNLESS OTHERWISE SPECIFIED: DIMENSIONS ARE IN INCHES TOLERANCES .XX=±.010 ANGLES ±1/2' .XXX=±.005 CONCENTRICITY: .003 TIR DO NOT SCALE DRAWING	DRAWN BY: PMK	11-27-07	TITLE INSTALLATION DWG, MOUNTING, BLOWER, SS, 8339 CEILOMETER	ADB SAFEGATE
	MATL AS ISSUED	REVISD BY:			
	FINISH AS ISSUED	CHECKED BY: J CONNER	11-27-07		
	TREATMENT NONE	DESIGN ENGINEER: J CONNER	11-27-07		
		PROJECT MANAGER:			
	APPROVALS	DATE	SCALE NONE	RELEASE DATE	SHEET 1 OF 1
			SIZE C	DWG NO. 83397-00-007	

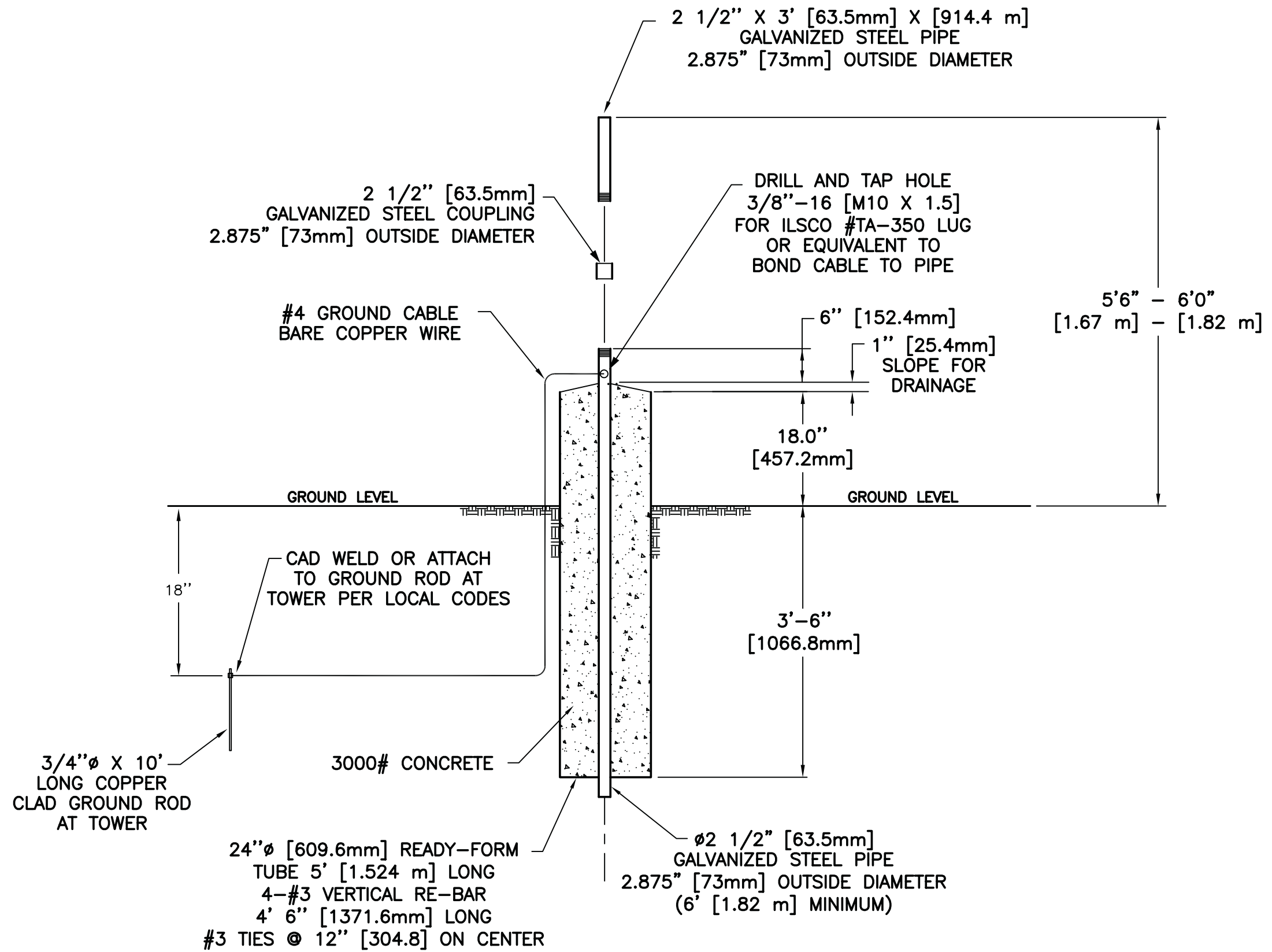

Ceilometer Site Preparation



Applicant: All Weather, Inc.
1165 National Drive, Sacramento, CA 95834
Tel: 916-928-1000 Fax: 916-928-1165

DECLARATION OF CONFORMITY
According to ISO/IEC Guide 22 and EN 45014

We, EMC Compliance Management Group declare under our sole responsibility that the product:

- Product Descriptions** : Cloud Height Indicators
- Model Names** : CEILOMETER 25K + BLOWER (100-120VAC)
CEILOMETER 25K + BLOWER (200-240VAC)
CEILOMETER 40K + BLOWER (100-120VAC)
CEILOMETER 40K + BLOWER (200-240VAC)
- Model Numbers** : 8339-F + 83396, 8339-G + 83397
8340-F + 83396, 8340-G + 83397
- Test Report Number** : ALL-0502-4469-SAFETY
- Date of Testing** : 2005, September 22nd - 23rd
- Manufactured by** : All Weather, Inc.
- Manufacturer's Address** : 1165 National Drive, Sacramento, CA 95834

The product herewith conforms to the following Council Directives:
The Low Voltage Directive 73/23/EEC

Conforms to the following product specifications:
EN 61010 – 1: 2001 (2nd Edition)

Responsible Party:

Issued by Test Laboratory:

Manufacturer: _____

Signature: _____

Responsible Person: _____

Title: _____

Phone Number: _____

Date: _____



Signed by: _____

Name: Steve Hsu

Title: Safety QC Manager

Date of Issue: 2005, November 2

Digital Certificate, EMC Compliance Management Group, 2005



Applicant: All Weather, Inc.
 1165 National Drive, Sacramento, CA 95834
 Tel: 916-928-1000 Fax: 916-928-1165

DECLARATION OF CONFORMITY
 According to ISO/IEC Guide 22 and EN 45014

We, EMC Compliance Management Group declare under our sole responsibility that the product:

- Product Descriptions :** Cloud Height Indicators
- Model Names :** CEILOMETER 25K + BLOWER (100-120VAC)
 CEILOMETER 25K + BLOWER (200-240VAC)
 CEILOMETER 40K + BLOWER (100-120VAC)
 CEILOMETER 40K + BLOWER (200-240VAC)
- Model Numbers :** 8339-F + 83396, 8339-G + 83397, 8340-F + 83396, 8340-G + 83397
- Test Report Number :** ALL-0502-4468-CE
- Date of Testing :** 2005, September 20th - 22nd
- Manufactured by :** All Weather, Inc.
- Manufacturer's Address :** 1165 National Drive, Sacramento, CA 95834

The product herewith conforms to the following Council Directives:
 The EMC Directive 89/336/EEC

This Declaration of Conformity is based upon compliance of the product with the harmonised EMC Directive:

- EN 61326 04: 1997 + A1 06: 1998 + A2: 2001 - Emissions
- EN55011:1998 + A1:1999, CISPR 11:2003 Edition 4.1:2004, Class A Radiated and Conducted Emissions.
- EN 61326 04: 1997 + A1 06: 1998 + A2: 2001, According to table A.1 – Immunity test requirements for equipment intended for use in industrial locations - Immunity
- IEC 61000-4-2 Edition 1.2 (2001), Electrostatic Discharge Immunity Test.
- IEC 61000-4-3:2002, Radiated, Radio-Frequency Electromagnetic Field Immunity Test.
- IEC 61000-4-4:2004, Electrical Fast Transient/Burst Immunity Test.
- IEC 61000-4-5 Edition 1.1:2001, Surge Immunity Test.
- IEC 61000-4-6 Edition 2.0 (2003), Immunity to Conducted Disturbances Test.
- IEC 61000-4-8 Edition 1.1 (2001), Power Frequency Magnetic Field Immunity Test.
- IEC 61000-4-11:2004, Voltage Dips and Short Interruptions Immunity Test.

Responsible Party:

Manufacturer: _____

Signature: _____

Responsible Person: _____

Title: _____

Date: _____

Issued by Test Laboratory:



This is the result of tests that were carried out from the submitted product sample(s) in conformity with the specification of the respective standards. The certification holder has the right to affix the CE-Mark for EMC on the product complying with the inspection sample.

Signed by: Joy Wang

Name: Tony Wang

Title: QC Manager

Date of Issue: 2005, September 30



Digital Certificate, EMC Compliance Management Group, 2005

Optimizing Airside Operations From approach to take-off

SMARTER. BETTER. **NOW.**

**ADB
SAFEGATE**
www.adbsafegate.com