

Type : 1150x700

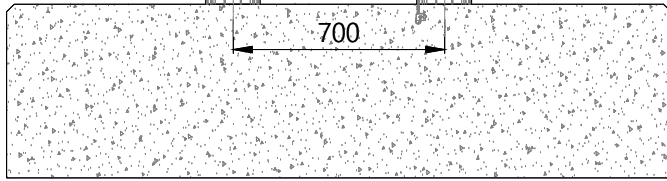

FRONT VIEW
SIGN 1150x700mm
Scale 1/25

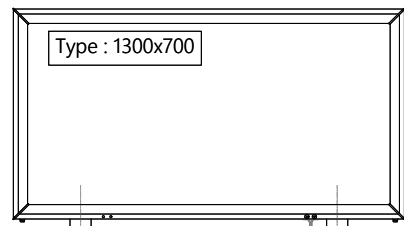

Type : 1300x700

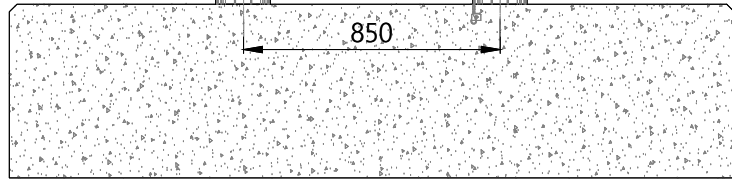

FRONT VIEW
SIGN 1300x700mm
Scale 1/25

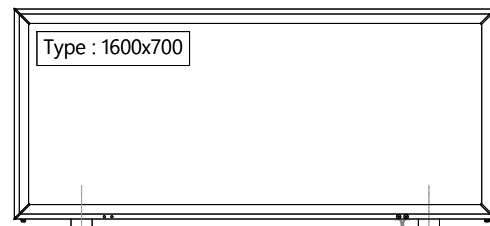

Type : 1600x700

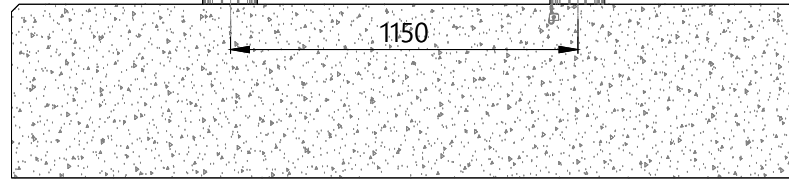

FRONT VIEW
SIGN 1600x700mm
Scale 1/25

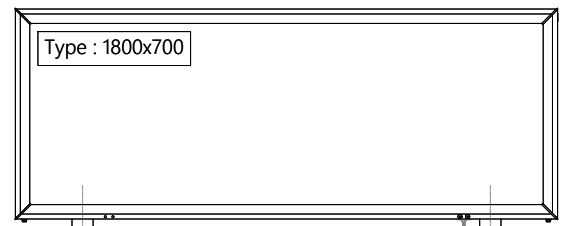

Type : 1800x700

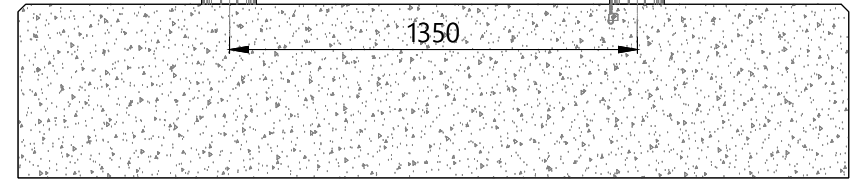

FRONT VIEW
SIGN 1800x700mm
Scale 1/25

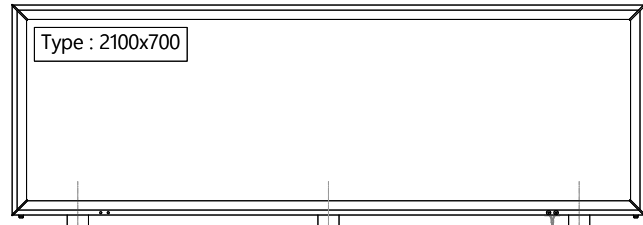

Type : 2100x700

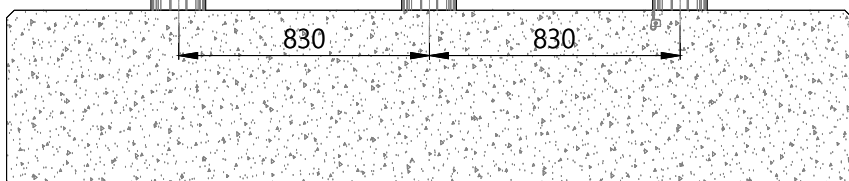

FRONT VIEW
SIGN 2100x700mm
Scale 1/25

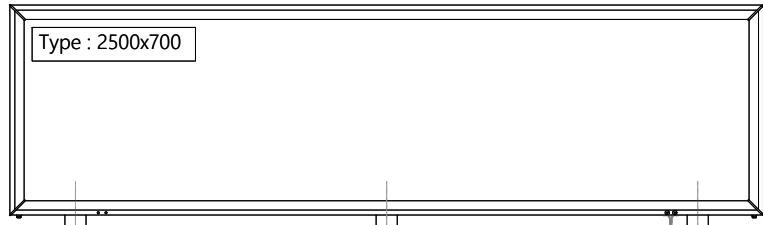

Type : 2500x700

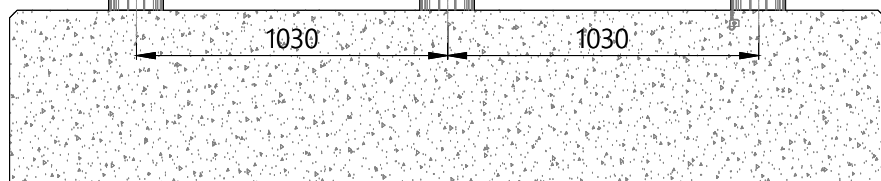

FRONT VIEW
SIGN 2500x700mm
Scale 1/25



Type : 2650x700

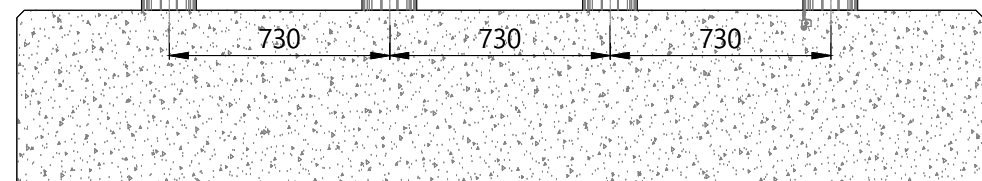

FRONT VIEW
SIGN 2650x700mm
Scale 1/25

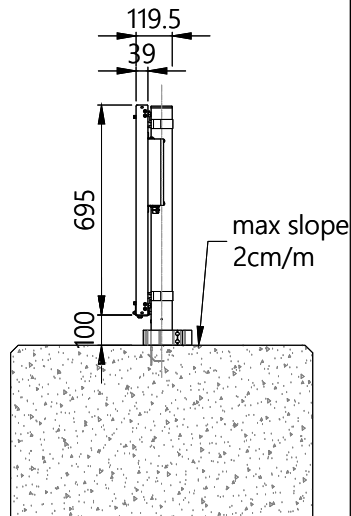

SIDE VIEW
SIGN 700mm
Scale 1/25

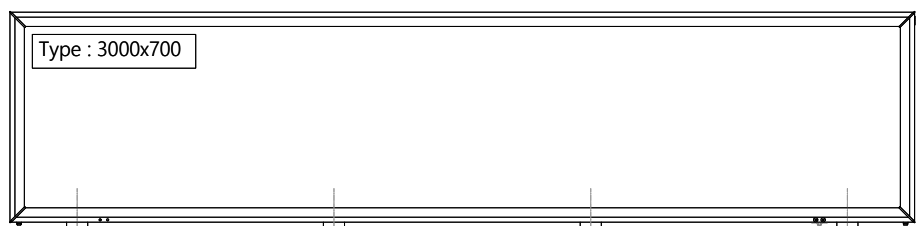

Type : 3000x700

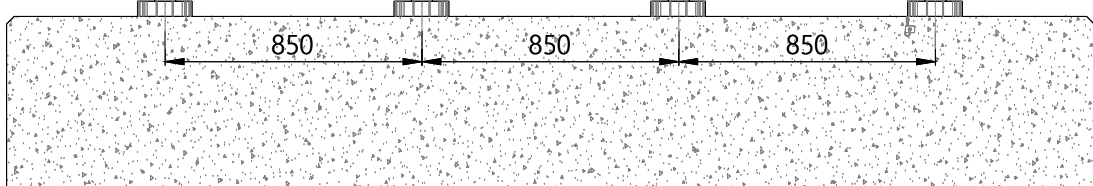

FRONT VIEW
SIGN 3000x700mm
Scale 1/25

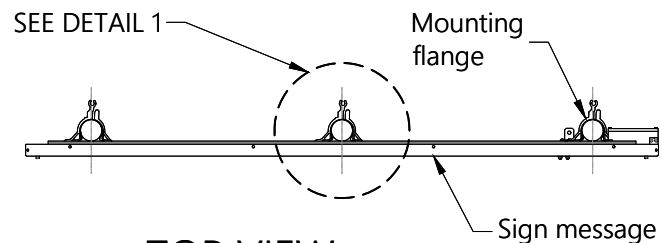

TOP VIEW
RELIANCE SIGN
Scale 1/25

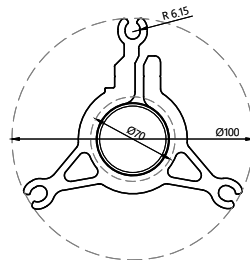

DETAIL 1

NOTES:

1. This drawing shows general installation details related to ADB Safegate products and is for information only, not for construction. The designer must verify compliance of design with local standards and varying characteristics for each unique airfield project.
2. Foundation sizes provided do not exceed 93% overturning capacity at point of post failure under jet blast loading (i.e. 322 km/hr).
3. Minimal reinforcement should be provided for foundation lengths of 2m or longer.
4. Design assumes good, well drained soil with a water table below the foundation base.
5. Ground conditions must be reviewed before selecting foundation sizes.
6. Contractor to ensure 98% maximum dry density (MDD) at base of foundation.
7. Type and quality of concrete to be as per civil specification for buried load bearing structures for the airport in question.
8. ADB Safegate waives its liability for wrongful use of the information.



TAXIWAY INFORMATION SIGNS
RELIANCE SIGNS - 700 mm
TYPICAL INSTALLATION DETAILS
MODE 2 ICAO Wind Load Requirement 322 km/h

SCALE: 1/25	UNIT: mm
DRAWN BY: EK	CHECKED BY: TH
DATE: 16/09/2022	SHEET: 1-2
ADBSG_A_SIGN_RELIANCE_Mode2_00	

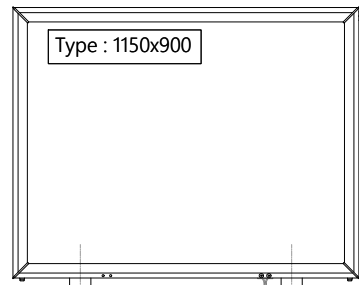

Type : 1150x900

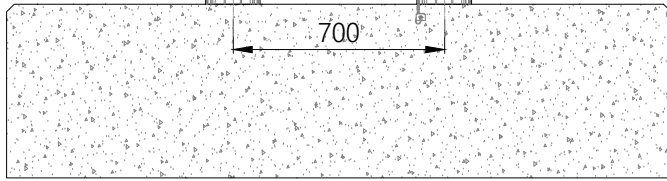

700

FRONT VIEW
SIGN 1150x900mm
Scale 1/25

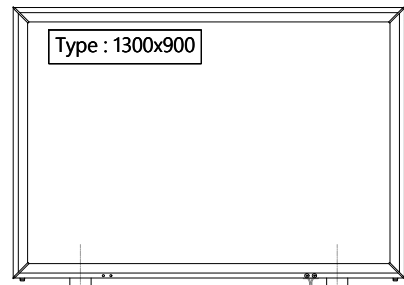

Type : 1300x900

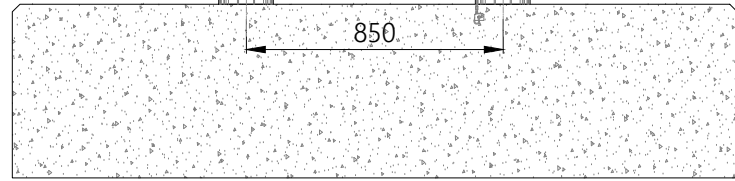

850

FRONT VIEW
SIGN 1300x900mm
Scale 1/25

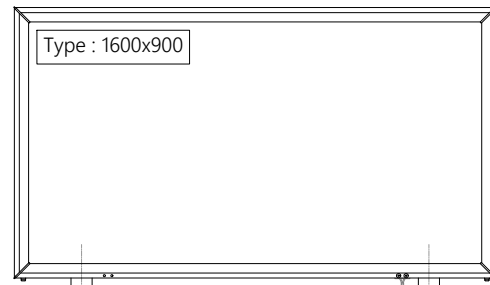

Type : 1600x900

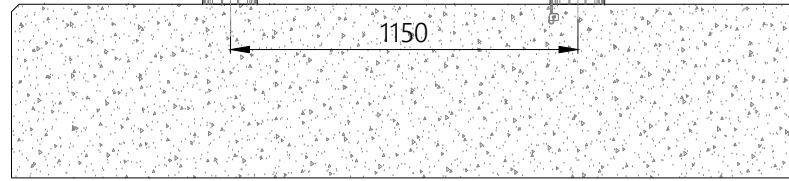

1150

FRONT VIEW
SIGN 1600x900mm
Scale 1/25

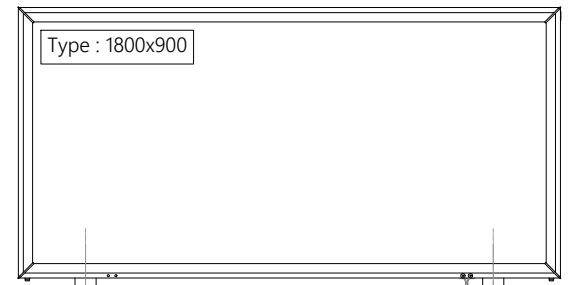

Type : 1800x900

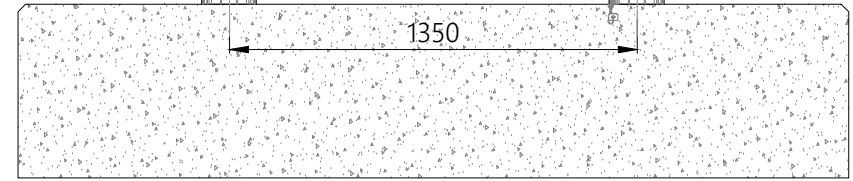

1350

FRONT VIEW
SIGN 1800x900mm
Scale 1/25

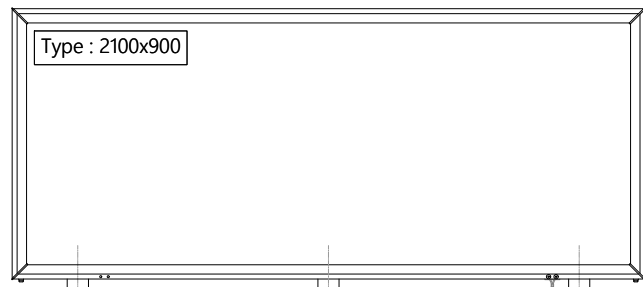

Type : 2100x900

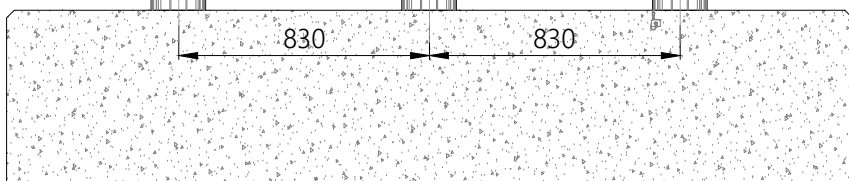

830

830

FRONT VIEW
SIGN 2100x900mm
Scale 1/25

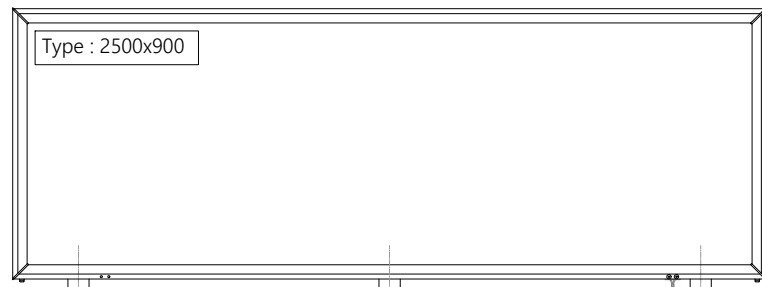

Type : 2500x900

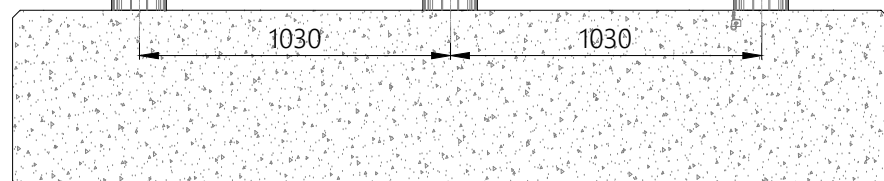

1030

1030

FRONT VIEW
SIGN 2500x900mm
Scale 1/25

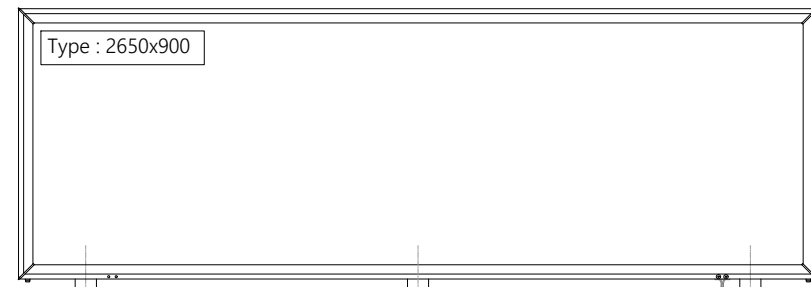

Type : 2650x900

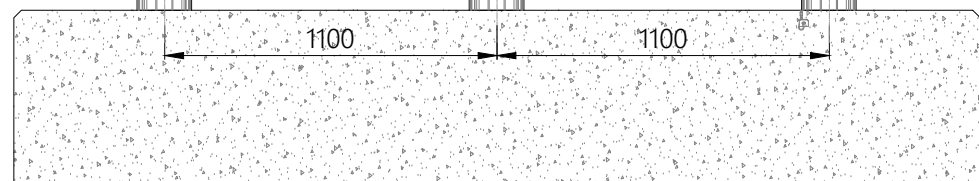

1100

1100

FRONT VIEW
SIGN 2650x900mm
Scale 1/25

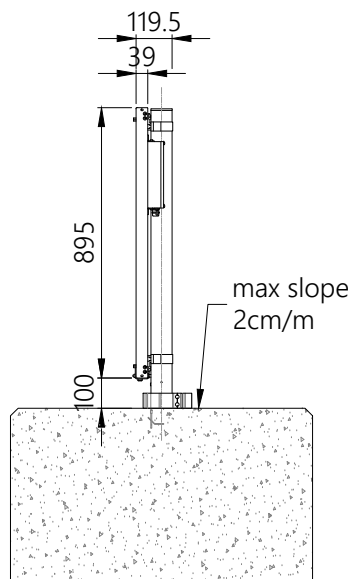

119.5

39

895

100

max slope
2cm/m

SIDE VIEW
SIGN 900mm
Scale 1/25

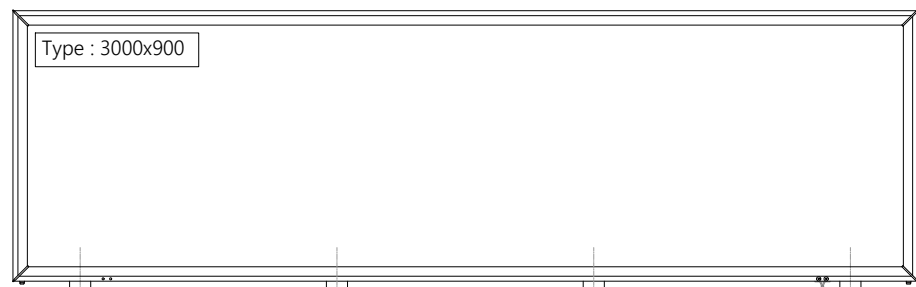

Type : 3000x900

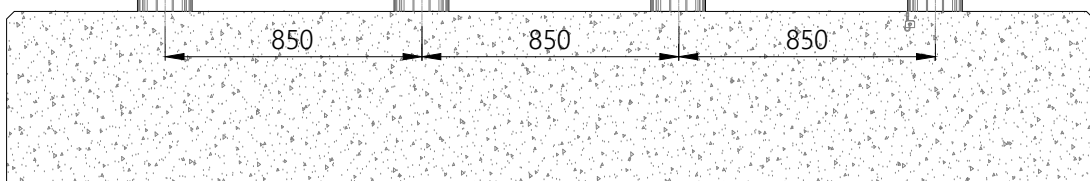

850

850

850

FRONT VIEW
SIGN 3000x900mm
Scale 1/25

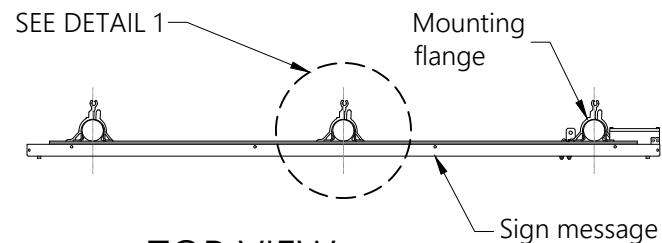

SEE DETAIL 1

Mounting
flange

Sign message

TOP VIEW
RELIANCE SIGN
Scale 1/25

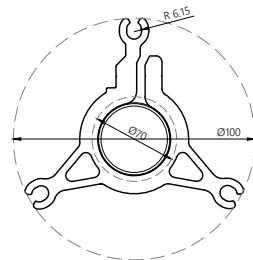

DETAIL 1

NOTES:

1. This drawing shows general installation details related to ADB Safegate products and is for information only, not for construction. The designer must verify compliance of design with local standards and varying characteristics for each unique airfield project.
2. Foundation sizes provided do not exceed 93% overturning capacity at point of post failure under jet blast loading (i.e. 322 km/hr).
3. Minimal reinforcement should be provided for foundation lengths of 2m or longer.
4. Design assumes good, well drained soil with a water table below the foundation base.
5. Ground conditions must be reviewed before selecting foundation sizes.
6. Contractor to ensure 98% maximum dry density (MDD) at base of foundation.
7. Type and quality of concrete to be as per civil specification for buried load bearing structures for the airport in question.
8. ADB Safegate waives its liability for wrongful use of the information.



TAXIWAY INFORMATION SIGNS
RELIANCE SIGNS -900 mm
TYPICAL INSTALLATION DETAILS
MODE 2 ICAO Wind Load Requirement 322 km/h

SCALE: 1/25	UNIT: mm
DRAWN BY: EK	CHECKED BY: TH
DATE: 16/09/2022	SHEET: 2-2
ADBSG_A_SIGN_RELIANCE_Mode2_00	