



RELIANCE EREL / ERES

User Manual

UM-3025 / AM.03.120e /US Version, Rev. 4.1, 2025/02/25



A.0 Disclaimer / Standard Warranty

CE certification

The equipment listed as CE certified means that the product complies with the essential requirements concerning safety and hygiene. The European directives that have been taken into consideration in the design are available on written request to ADB SAFEGATE.

ETL certification

The equipment listed as ETL certified means that the product complies with the essential requirements concerning safety and FAA Airfield regulations. The FAA directives that have been taken into consideration in the design are available on written request to ADB SAFEGATE.

All Products Guarantee

ADB SAFEGATE will correct by repair or replacement per the applicable guarantee above, at its option, equipment or parts which fail because of mechanical, electrical or physical defects, provided that the goods have been properly handled and stored prior to installation, properly installed and properly operated after installation, and provided further that Buyer gives ADB SAFEGATE written notice of such defects after delivery of the goods to Buyer. Refer to the Safety section for more information on Material Handling Precautions and Storage precautions that must be followed.

ADB SAFEGATE reserves the right to examine goods upon which a claim is made. Said goods must be presented in the same condition as when the defect therein was discovered. ADB SAFEGATE further reserves the right to require the return of such goods to establish any claim.

ADB SAFEGATE's obligation under this guarantee is limited to making repair or replacement within a reasonable time after receipt of such written notice and does not include any other costs such as the cost of removal of defective part, installation of repaired product, labor or consequential damages of any kind, the exclusive remedy being to require such new parts to be furnished.

ADB SAFEGATE's liability under no circumstances will exceed the contract price of goods claimed to be defective. Any returns under this guarantee are to be on a transportation charges prepaid basis. For products not manufactured by, but sold by ADB SAFEGATE, warranty is limited to that extended by the original manufacturer. This is ADB SAFEGATE's sole guarantee and warranty with respect to the goods; there are no express warranties or warranties of fitness for any particular purpose or any implied warranties of fitness for any particular purpose or any implied warranties other than those made expressly herein. All such warranties being expressly disclaimed.

Standard Products Guarantee

Products manufactured by ADB SAFEGATE are guaranteed against mechanical, electrical, and physical defects (excluding lamps) which may occur during proper and normal use for a period of two years from the date of ex-works delivery, and are guaranteed to be merchantable and fit for the ordinary purposes for which such products are made.



Note

See your sales order contract for a complete warranty description.

FAA Certified products manufactured by ADB SAFEGATE

ADB SAFEGATE L858 Airfield Guidance Signs are warranted against mechanical and physical defects in design or manufacture for a period of 2 years from date of installation, per FAA AC 150/5345-44 (applicable edition).

ADB SAFEGATE LED products (with the exception of obstruction lighting) are warranted against electrical defects in design or manufacture of the LED or LED specific circuitry for a period of 4 years from date of installation, per FAA EB67 (applicable edition). These FAA certified constant current (series) powered LED products must be installed, interfaced and powered with and through products certified under the FAA Airfield Lighting Equipment Program (ALECP) to be included in this 4 (four) year warranty. This includes, but is not limited to, interface with products such as Base Cans, Isolation Transformers, Connectors, Wiring, and Constant Current Regulators.

**Note**

See your sales order contract for a complete warranty description.

Replaced or repaired equipment under warranty falls into the warranty of the original delivery. No new warranty period is started for these replaced or repaired products.

Liability

**WARNING**

Use of the equipment in ways other than described in the catalog leaflet and the manual may result in personal injury, death, or property and equipment damage. Use this equipment only as described in the manual.

ADB SAFEGATE cannot be held responsible for injuries or damages resulting from non-standard, unintended uses of its equipment. The equipment is designed and intended only for the purpose described in the manual. Uses not described in the manual are considered unintended uses and may result in serious personal injury, death or property damage.

Unintended uses, includes the following actions:

- Making changes to equipment that have not been recommended or described in this manual or using parts that are not genuine ADB SAFEGATE replacement parts or accessories.
- Failing to make sure that auxiliary equipment complies with approval agency requirements, local codes, and all applicable safety standards if not in contradiction with the general rules.
- Using materials or auxiliary equipment that are inappropriate or incompatible with your ADB SAFEGATE equipment.
- Allowing unskilled personnel to perform any task on or with the equipment.

© ADB SAFEGATE BV

This manual or parts thereof may not be reproduced, stored in a retrieval system, or transmitted, in any form or by any means, electronic, mechanical, photocopying, recording, nor otherwise, without ADB SAFEGATE BV's prior written consent.

This manual could contain technical inaccuracies or typographical errors. ADB SAFEGATE BV reserves the right to revise this manual from time to time in the contents thereof without obligation of ADB SAFEGATE BV to notify any person of such revision or change. Details and values given in this manual are average values and have been compiled with care. They are not binding, however, and ADB SAFEGATE BV disclaims any liability for damages or detriments suffered as a result of reliance on the information given herein or the use of products, processes or equipment to which this manual refers. No warranty is made that the use of the information or of the products, processes or equipment to which this manual refers will not infringe any third party's patents or rights. The information given does not release the buyer from making their own experiments and tests.

TABLE OF CONTENTS

1.0 Safety	1
1.1 Safety Messages	1
1.1.1 Introduction to Safety	2
1.1.2 Intended Use	2
1.1.3 Material Handling Precautions: Storage	3
1.1.4 Arc Flash and Electric Shock Hazard	3
2.0 RELIANCE EREL / ERES	5
2.1 Abbreviations and terms	5
2.2 Runway Edge, Stopway and Threshold/End, L-862(L) and L-862E(L)	5
2.3 IQ function load (option)	8
2.4 2A system	8
2.5 Identification on the fixture	8
2.6 Frangible coupling	8
2.7 Runway Threshold combined with Runway End fixtures	9
2.8 Monitoring (option)	9
2.9 Arctic kit (option)	9
3.0 Install or Replace the RELIANCE EREL/ERES Fixture	11
3.1 Inspect on delivery	11
3.2 Storage	11
3.3 Installation	11
3.3.1 Intended Use	12
3.3.2 Preparation	12
3.3.3 Installation	13
3.3.4 Alignment guidelines	13
3.3.5 Install the alignment tool on the fixture	13
3.3.6 leveling and alignment	14
3.3.7 Examination of the alignment	15
3.3.8 Finish	16
3.4 Remove	16
4.0 RELIANCE EREL/ERES Maintenance	17
4.1 Maintenance Safety	17
4.2 Preventive maintenance schedule	17
4.3 Part replacement	18
4.3.1 Part replacement - general procedure	18
4.3.2 Part replacement - complete optical head	19
4.3.3 Part replacement - optical cover	21
4.3.4 Part replacement - optical kit	23
4.3.5 Part replacement - arctic kit (arctic kit option)	25
4.3.6 Part replacement - body	27
4.3.7 Part replacement - cooling block	28
4.3.8 Part replacement - body support assembly	29
4.3.9 Part replacement - cable lead, Earthing wire and cable bushing	30
4.3.10 Part replacement - frangible coupling or column	32
4.3.11 Repair a faulty light (monitoring option)	33
4.3.12 Part replacement - fuse resistor (monitoring option)	34
4.3.13 Assemble the complete optical head	34
4.4 Fixture operation test	35
5.0 RELIANCE EREL/ERES Troubleshooting	37
5.1 Operation Safety	37
5.2 Troubleshooting guide	37
6.0 Parts and Technical data	39
6.1 Exploded view	40

6.2 EREL/ERES Parts	41
6.3 Screws and torques	42
6.4 Options and accessories	43
A.0 SUPPORT	45
A.1 ADB SAFEGATE Website	45
A.2 Recycling	46
A.2.1 Local Authority Recycling	46
A.2.2 ADB SAFEGATE Recycling	46

1.0 Safety

Introduction to Safety

This section contains general safety instructions for installing and using ADB SAFEGATE equipment. Some safety instructions may not apply to the equipment in this manual. Task- and equipment-specific warnings are included in other sections of this manual where appropriate.

1.1 Safety Messages

HAZARD Icons used in the manual

For all HAZARD symbols in use, see the Safety section. All symbols must comply with ISO and ANSI standards.

Carefully read and observe all safety instructions in this manual, which alert you to safety hazards and conditions that may result in personal injury, death or property and equipment damage and are accompanied by the symbol shown below.



WARNING

Failure to observe a warning may result in personal injury, death or equipment damage.



DANGER - Risk of electrical shock or ARC FLASH

Disconnect equipment from line voltage. Failure to observe this warning may result in personal injury, death, or equipment damage. ARC Flash may cause blindness, severe burns or death.



WARNING - Wear personal protective equipment

Failure to observe may result in serious injury.



WARNING - Do not touch

Failure to observe this warning may result in personal injury, death, or equipment damage.



CAUTION

Failure to observe a caution may result in equipment damage.

Qualified Personnel



Important Information

The term **qualified personnel** is defined here as individuals who thoroughly understand the equipment and its safe operation, maintenance and repair. Qualified personnel are physically capable of performing the required tasks, familiar with all relevant safety rules and regulations and have been trained to safely install, operate, maintain and repair the equipment. It is the responsibility of the company operating this equipment to ensure that its personnel meet these requirements.

Always use required personal protective equipment (PPE) and follow safe electrical work practice.

1.1.1 Introduction to Safety



CAUTION

Unsafe Equipment Use

This equipment may contain electrostatic devices, hazardous voltages and sharp edges on components

- Read installation instructions in their entirety before starting installation.
- Become familiar with the general safety instructions in this section of the manual before installing, operating, maintaining or repairing this equipment.
- Read and carefully follow the instructions throughout this manual for performing specific tasks and working with specific equipment.
- Make this manual available to personnel installing, operating, maintaining or repairing this equipment.
- Follow all applicable safety procedures required by your company, industry standards and government or other regulatory agencies.
- Install all electrical connections to local code.
- Use only electrical wire of sufficient gauge and insulation to handle the rated current demand. All wiring must meet local codes.
- Route electrical wiring along a protected path. Make sure they will not be damaged by moving equipment.
- Protect components from damage, wear, and harsh environment conditions.
- Allow ample room for maintenance, panel accessibility, and cover removal.
- Protect equipment with safety devices as specified by applicable safety regulations
- If safety devices must be removed for installation, install them immediately after the work is completed and check them for proper functioning prior to returning power to the circuit.

Failure to follow this instruction can result in serious injury or equipment damage

Additional Reference Materials



Important Information

- IEC - International Standards and Conformity Assessment for all electrical, electronic and related technologies.
- IEC 60364 - Electrical Installations in Buildings.
- FAA Advisory: AC 150/5340-26 (current edition), Maintenance of Airport Visual Aid Facilities.
- Maintenance personnel must refer to the maintenance procedure described in the ICAO Airport Services Manual, Part 9.
- ANSI/NFPA 79, Electrical Standards for Metalworking Machine Tools.
- National and local electrical codes and standards.

1.1.2 Intended Use



CAUTION

Use this equipment as intended by the manufacturer

This equipment is designed to perform a specific function, do not use this equipment for other purposes

- Using this equipment in ways other than described in this manual may result in personal injury, death or property and equipment damage. Use this equipment only as described in this manual.

Failure to follow this instruction can result in serious injury or equipment damage

1.1.3 Material Handling Precautions: Storage



CAUTION

Improper Storage

Store this equipment properly

- If equipment is to be stored prior to installation, it must be protected from the weather and kept free of condensation and dust.

Failure to follow this instruction can result in equipment damage

1.1.4 Arc Flash and Electric Shock Hazard



DANGER

Series Circuits have Hazardous Voltages

This equipment produces high voltages to maintain the specified current - Do NOT Disconnect while energized.

- Allow only qualified personnel to perform maintenance, troubleshooting, and repair tasks.
- Only persons who are properly trained and familiar with ADB SAFEGATE equipment are permitted to service this equipment.
- An open airfield current circuit is capable of generating >5000 Vac and may appear OFF to a meter.
- Never unplug a device from a constant current circuit while it is operating; Arc flash may result.
- Disconnect and lock out electrical power.
- Always use safety devices when working on this equipment.
- Follow the recommended maintenance procedures in the product manuals.
- Do not service or adjust any equipment unless another person trained in first aid and CPR is present.
- Connect all disconnected equipment ground cables and wires after servicing equipment. Ground all conductive equipment.
- Use only approved ADB SAFEGATE replacement parts. Using unapproved parts or making unapproved modifications to equipment may void agency approvals and create safety hazards.
- Check the interlock systems periodically to ensure their effectiveness.
- Do not attempt to service electrical equipment if standing water is present. Use caution when servicing electrical equipment in a high-humidity environment.
- Use tools with insulated handles when working with airfield electrical equipment.

Failure to follow these instructions can result in death or equipment damage

2.0 RELIANCE EREL / ERES

About this manual

The manual shows the information necessary to:

- install
- carry out maintenance
- carry out troubleshooting on the RELIANCE Elevated Runway Edge Light, type EREL/ ERES, in the manual referred to as the fixture.

2.1 Abbreviations and terms

Term or abbreviation	Description
C/L	Center Line
EREL	Elevated Runway Edge light, synthetic lens
ERES	Elevated Runway Edge light, glass lens
FAA	Federal Aviation Administration
FOD	Foreign Object Debris
ICAO	International Civil Aviation Organization
IEC	International Electrical Committee
ISO	International Standardization Organization
LED	Light Emitting Diode
Mounting support	A piece of equipment permanently installed on the ground, on which the fixture is installed with a frangible coupling device.
OAH	All Over Height
PCB	Printed Circuit Board
Toe-in	The toe-in angle is the angle the beam of light makes with the longitudinal axis of the runway or taxiway.
TPI	Turns Per Inch
UNC	Unified Thread Standard

2.2 Runway Edge, Stopway and Threshold/End, L-862(L) and L-862E(L)

Compliance with Standards (current edition)

FAA	L-862(L) and L-862E(L) AC 150/5345-46 and the FAA Engineering Brief No. 67. ETL certified.
ICAO	Annex 14 Volume I
EASA	CS-ADR-DSN
Canada	TP 312
NATO	STANAG 3316

Uses

ICAO

- Runway Edge for runways up to 60 m wide
- Runway End
- Runway Threshold
- Runway Threshold/End
- Runway Stopway

FAA

- Runway Edge L-862(L)
- Runway End L-862E(L)
- Runway Threshold L-862E(L)
- Runway Threshold/End L-862E(L)

Features & Benefits

- Available in three versions:
 - RELIANCE® IQ with integrated ILCMS
 - Monitored with integrated fail-open technology
 - Non-Mon without monitoring functionality
- Very low energy consumption (typically 30 W for a bidirectional light, and 25 W for an unidirectional light, compared to 120, 150 or 200 W for tungsten halogen lights).
- Greatly reduced maintenance: calculated MTBF of 56,000 hours at 6.6A.
- Increased availability of the runway thanks to the reduction of maintenance.
- Optimum and homogeneous light distribution along the lights installed on the same runway.
- High discrimination between functions thanks to the saturated colors, their stability at the different brightness steps and under all viewing angles.
- Circular guidance achieved by LED closest to the top on each side for applicable applications.
- Fully dimmable lights, respecting the response curve of traditional halogen lights. Operates on the full range of 2.8 A to 6.6 A.
- Installation on same mounting device as most elevated halogen lights, for a straightforward replacement.
- Substantial investment reduction for new installations, resulting from a lower installed load.
- Very low working temperature, ensuring longer component life.
- Rugged lightning protection that complies with ANSI/IEEE C62.41 -1991 Location Category C2 given in FAA Eng. Brief 67. Category C2 is defined as a 1.2/50µS - 8/20 µS combination wave, with a peak voltage of 10,000 V and a peak current of 5.000 A.
- Compatibility between RELIANCE IQ version and RELIANCE Intelligent Lighting 2A system for further power savings and ILCMS.
- When turned on, light rise time is low. The light is perfectly adapted for any incursion protection system.
- Optional monitoring function of the individual light source. In case of a defect, the LED light automatically disconnects from the secondary side of the isolation transformer, resulting in an open circuit condition.
- Low-profile and small in size to withstand heaviest jet blast, even when installed at threshold/runway end.
- Options for either glass or UV-resistant polycarbonate outer lens.
- Leveling and aiming in azimuth of the fixture are easily performed with the dedicated aiming device.
- Three screws allow a 4° leveling adjustment of the fixture after installation.

- Use of LED light source eliminates filter replacement and color shifts when viewed at various angles or CCR step settings.
- Upper body can be replaced without realignment of the fixture.
- Sealed entry at cord set to optical assembly interface prevents insect entry. IP 66 protection degree.
- Omnidirectional beam for circular guidance is standard for bidirectional Runway Edge fixture. No need for additional optical system.
- Finish: stainless steel hardware, phosphating and baked polyester electrostatic powder coating, aviation yellow color.

Toe-in Color Coding

For toe-in, the part number scheme assumes the observer is facing both the light and the runway centerline. For example, toe-in option 3 means that both the left and right side are toed in the direction of the centerline. If the equipment (A) has a toe-in (D), the toe-in is in compliance with the relevant ICAO or FAA requirements. The indication left side (L) or right side (R) always refers from the equipment to the centerline (C) of the runway (B).

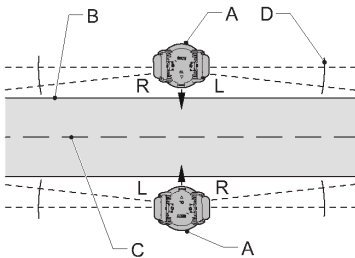

Power Supply

Non-MON and MON lights have been designed to work with any IEC- or FAA-compliant transformer up to 150 W. See the manual for calculation of actual circuit VA loads. IQ lights can work with transformers up 300W.

Fixture type	Fixture load	Isolation transformer size	Isol. XF load	CCR load
Without Arctic Kit				
Bidirectional	33 VA	30/45 W or 45 W	10 VA	43 VA
Unidirectional	29 VA	20/25 W or 30/45 W	10 VA	39 VA
With Arctic Kit				
Bidirectional	38 VA	30/45 W or 45 W	10 VA	48 VA
Unidirectional	41 VA	30/45 W or 45 W	10 VA	41 VA

Dimensions and Weight

Diameter and height	166 × 233 mm / 6.54 × 9.17-in Without mounting interface
Weight	3.36 kg / 7.41 lb

Accessories

Aiming Device	1408.35.130
----------------------	-------------

For more information about the product, including manuals, certifications and photometric data, please see our Product Center on the ADB SAFEGATE website, www.adbsafegate.com.

2.3 IQ function load (option)

With IQ enabled an additional capacity of 12 W need to be added to the transformer calculations for the powerline communication of the ILCMS. This has to be available for the communication to pass through without saturating the transformer (this power is not used and should not be included in the CCR calculation).



CAUTION

RELIANCE IQ is not to be connected to transformers smaller than 65 W.

2.4 2A system

When dimensioning the isolation transformer size for a 2A-system, that is a series circuit with RELIANCE IQ 2A which is only supposed to run at 2A, it is important to know that the regular method by adding up the total wattage on the isolation transformer secondary side, cannot be used. This is because a standard isolation transformer 6.6A/6.6A is marked with a maximum wattage running at 6.6A. According to the Lenz Law of Induction, the dimensioning property of a transformer is the total voltage, and not the wattage, of the secondary side of the transformer in a 50/60Hz series circuit system.

The consequence in a 2A-system is the wattage marked on a 6.6A/6.6A isolation transformer must generally be multiplied by 3.3 (6.6/2) to find the total wattage which can be supplied from the transformer without saturating.



Note

The same dimensioning method must be used for a CCR, as the transformer kVA-size marked on a CCR is normally calculated at 6.6A, not at 2A. There are also more constraints to consider such as spare capacity. For more information, contact ADB SAFEGATE for a complete CCR dimensioning procedure.

2.5 Identification on the fixture

A: Arrow. The arrow must always point to the center of the runway (CL).

B: ADB SAFEGATE logo.

C: Color of the optical cover. The color of the optical cover shows the color of the LEDs.

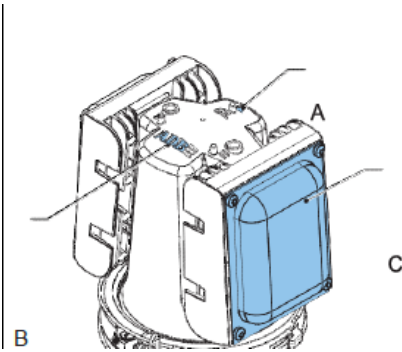

Note

Exception: the optical cover of the ICAO threshold is transparent and does not show the color of the LEDs.

2.6 Frangible coupling

A: Frangible coupling

B: Weakening groove

C: Mounting flange A

The fixture includes a frangible coupling with a weakening groove.

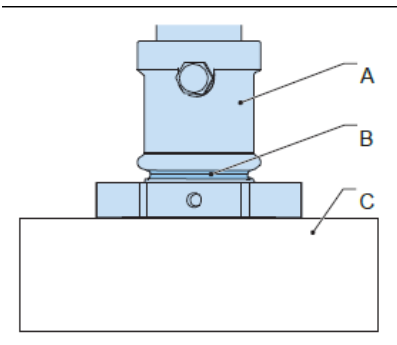

2.7 Runway Threshold combined with Runway End fixtures

If required the ICAO Runway Threshold/End position can be supplied either with two rows of unidirectional fixtures for each of the applications separately. Alternatively, it can be supplied with a bidirectional fixtures with both applications.

In the former case, the Threshold Green fixtures are not equipped with toe-in and shall be installed upon appropriate rotation of the fixture on the stem with respect to the mounting plate. In the latter case, only the centerline fixture has no toe-in on the green side. Positions displaced from the runway centerline shall be installed according to the scheme below.

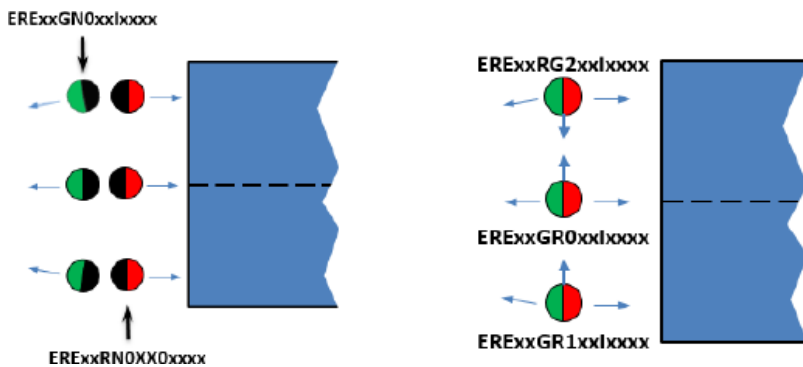

2.8 Monitoring (option)

The monitoring option is available. You can use the monitoring option with the Lamp Fault Detection of Constant Current Regulators or with Individual Light Control and Monitoring Systems (ILCMS) that check the status of the light by performing a continuity test on the secondary of the ILCMS remote module. The monitoring option does a check on the light. In case of a failure of the light, the failure is detected by the electronics embedded in the light.



WARNING

Ask your local representative for the compatibility of the ILCMS system and the light.

2.9 Arctic kit (option)

The arctic kit option is available, in compliance with FAA Engineering Brief EB67.

If the fixture has the arctic kit option, a thermostatically controlled heater prevents ice and snow buildup. This prevents a decrease of light output. This heater melts ice similar to traditional incandescent fixtures. The heater goes on only when the temperature drops below 0 degrees Celsius, to reduce the energy consumption.

The arctic kit is available on both glass and polycarbonate options.

3.0 Install or Replace the RELIANCE EREL/ERES Fixture

The procedure only gives information on how to replace the complete fixture. For information on how to replace parts of the fixture, see [Part replacement](#).

3.1 Inspect on delivery

1. Inspect all packing for visible damage.
2. Open every damaged box and inspect the contents for damage.
3. Immediately fill a claim form with the carrier if any equipment is damaged.
4. Store the equipment in its original packing in a protected area.



WARNING

Do not damage the cable insulation.



CAUTION

Do not unpack the equipment before the equipment is at the installation site to avoid damage due to transportation and handling.

3.2 Storage

Store the fixture in its original packing in a protected area.

Indoor storage:

- Storage temperature: -55°C to +50°C (-67°F to 131°F).
- Humidity: <100% condensing.

For long storage periods (longer than one year), we recommend to energize the LED lights once a year at nominal intensity (6.6Amps) for 20 minutes.

3.3 Installation



WARNING

- Only install the fixture on mounting supports:
 - That ADB SAFEGATE has approved
 - That are installed according to the Instruction Manual of the mounting support
 - Failure to do so can result in a highly dangerous situation of FOD, with potentially lethal consequences
- Do not damage the cable insulation
- Make sure the power to the series circuit is OFF when you install or remove any fixture.
- Make sure that the installation, alignment and the position of the fixture complies with FAA Advisory circular AC 150/5340-30 (latest revision) and ICAO Annex 14, Volume I, Para 5.3.9 for runway edge lights.



CAUTION

Make sure that:

- The fixture is powered from a 6.6 A series circuit.
 - The series circuit is powered by a Constant Current Regulator that complies with IEC 61822 or FAA AC 5345-10 (latest revision).
 - The transformer is series isolation transformer that complies with IEC 61823 or FAA AC 5345-47 (latest revision); the power of the series transformer shall not exceed 200 W. This does not apply for IQ or IQ 2A installations where larger transformers can or should be used. Please contact your sales representative for more information.
 - The mounting support is correctly earthed. Failure to do so will void the warranty for all damages that occur as a result of voltage surges.
-



Note

See the Instruction Manual of the mounting support for instructions on how to earth the mounting support.

Parts:

- Complete fixture

Tools:

- Open spanners
- Alignment tool

3.3.1 Intended Use



CAUTION

Use this equipment as intended by the manufacturer

This equipment is designed to perform a specific function, do not use this equipment for other purposes

- Using this equipment in ways other than described in this manual may result in personal injury, death or property and equipment damage. Use this equipment only as described in this manual.

Failure to follow this instruction can result in serious injury or equipment damage

3.3.2 Preparation

1. Make sure that the fixture is completely assembled.
2. Make sure that the fixture is operationally tested.

See [Fixture operation test](#) .

3.3.3 Installation

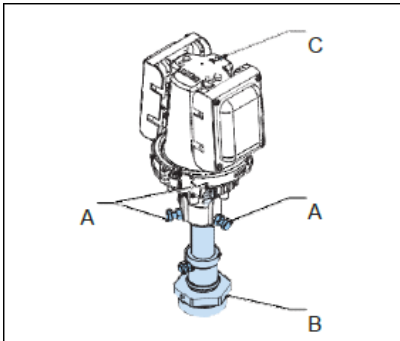

1. Connect the plug to the receptacle of the transformer.
2. If the fixture has is a separate earth ground wire, connect it.
3. Loosen the screws (A).
4. Place the fixture on the mounting support.
5. Turn in the frangible coupling (B).



Note

Do not turn the body support.

6. Tighten the frangible coupling (B) to the mounting support.
Use an open spanner that fits the hexagon of the frangible coupling.
7. Make sure the arrow (C) points to the center of the runway.

3.3.4 Alignment guidelines

The fixture is aligned in azimuth by looking at a reference mark through the alignment tool. Depending on the position of the fixture, the reference mark may be another light in the same row or a stick installed for this purpose. Usually, for runway edge lights another light of the same row is used. For threshold / runway end lights, a stick can be installed in the prolongation of the line of the threshold / runway end lights

3.3.5 Install the alignment tool on the fixture



Note

The alignment tool can be installed in four directions.

The direction of installation is dependent on the position of the reference mark you have chosen.

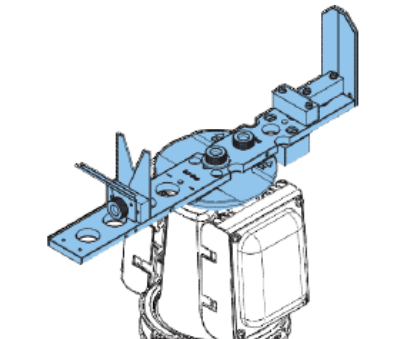

Install the alignment tool in the desired direction on top of the fixture.



CAUTION

Make sure that the center line mark of the fixture and the alignment tool point towards the runway.

3.3.6 leveling and alignment

Level the fixture

1. Move the fixture until it is level and hold it there. *Examine the spirit levels (A) and (B).*

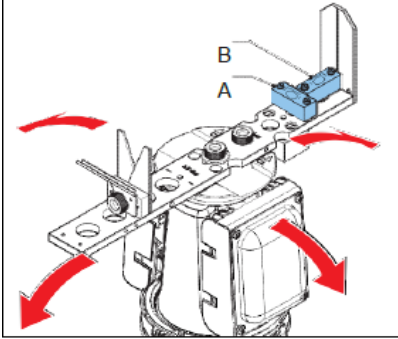

Align the fixture

1. From the top down, look into the mirror (A) and turn the fixture until it aligns with the other fixtures (B).
2. Hold the fixture in this position.
3. Examine again if the fixture is level.



Note

Do not tighten the screws on the stem until the adjustment is finished.

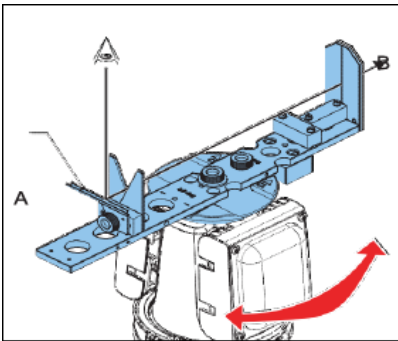

Finish

1. Tighten the alignment screws (A) gradually. See § [Screws and torques](#) (torque).



CAUTION

Tighten the alignment screws progressively to the correct torque.

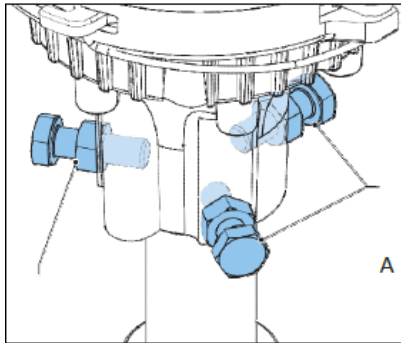

3.3.7 Examination of the alignment

Examine

1. Install the alignment tool. See [Install the alignment tool on the fixture](#) .
2. Look from the top down into the mirror (A).
3. Examine the spirit levels (B) and (C).
4. If the alignment is not correct or if the fixture is not level, align or level the fixture. See [Level the Alignment Tool](#).

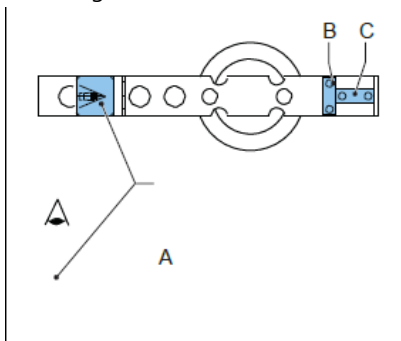

Finish

1. Remove the alignment tool.
2. Make sure that the arrow (A) points to the centre of the runway.

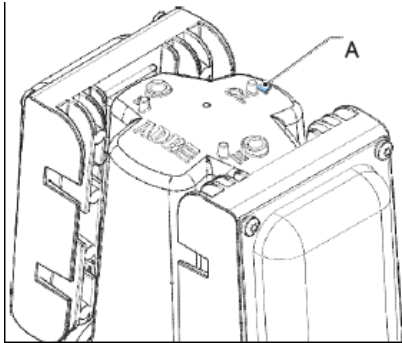

3.3.8 Finish

1. Examine the color of each lens.
2. Examine the toe-in.

3.4 Remove

Tools:

- Open spanner 50 mm
1. Loosen the nuts (A) and the screws (B).
 2. Loosen the frangible coupling (C).



Note
Do not turn the body support.

3. Disconnect the plug (D).
4. If the fixture has a separate earth ground wire, disconnect it.

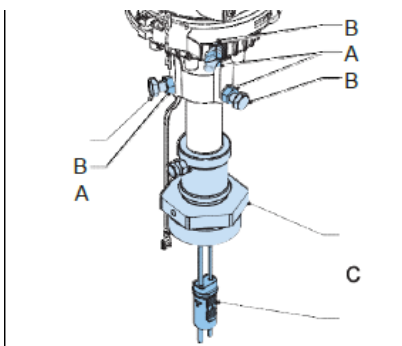

4.0 RELIANCE EREL/ERES Maintenance

Maintenance personnel must refer to the maintenance procedure described in the ICAO Airport Services Manual, Part 9, Airport maintenance practices and in FAA Advisory Circular N° AC150/5340-26.



WARNING

Do not carry out any action on the fixture unless you have read and understood all the information in the chapter 2.



WARNING

Make sure that the power to the series circuit is OFF when you carry out maintenance.

4.1 Maintenance Safety



DANGER

Electric Shock Hazard

This equipment may contain electrostatic devices

- Do not operate a system that contains malfunctioning components. If a component malfunctions, turn the system OFF immediately.
- Disconnect and lock out electrical power.
- Allow only qualified personnel to make repairs. Repair or replace the malfunctioning component according to instructions provided in its manual.

Failure to follow these instructions can result in death or equipment damage

4.2 Preventive maintenance schedule

Frequency	Check	Action
Daily	For low light output according to ICAO annex 14	<ul style="list-style-type: none"> - If the optical cover is dirty, clean the optical cover. - If the optical cover is not dirty, replace the complete optical head. See Part replacement . - and replace the faulty component in the workshop. See § Troubleshooting guide .
Weekly	For contamination	Clean the fixture.
Monthly	Visually for condensation on the inner side of the optical cover (presence of moisture or water) Condensation is an acceptable phenomenon, as long as it disappears when the equipment is in use.	Turn on the fixture for 30 minutes. In case the condensation has not disappeared: <ul style="list-style-type: none"> - Remove the optical cover. - Clean and dry the optical cover. - Replace the optical cover. gasket. See Part replacement - optical cover - Install the dry optical cover.
	For failed fixture	<ul style="list-style-type: none"> - Replace the complete optical head. See Part replacement . - and replace the faulty component in the workshop. See Troubleshooting guide.

Frequency	Check	Action
Semi-annually	For presence of water at the inside of the fixture	- Remove the optical cover - Dry and clean the optical cover. - Replace the optical cover gasket. - Install the dry optical cover.
	For correct alignment and if the fixture is level. See Examination of the alignment .	Adjust the alignment or level the fixture. See Examination of the alignment
	For correct torque of alignment screws and frangible coupling to column screws.	Refer step 1 in paragraph "Finish" in section 3.3.6 "Leveling and alignment" .
	For damaged paint	- Clean the fixture. - Paint the fixture again.
Yearly	For cracks, corrosion or short circuit	Clean the fixture and replace faulty or corroded parts. See Troubleshooting guide
	For dirty contacts	- Make sure that the power is OFF. - Clean the contact.
	For loose connections	Tighten or repair the connection.
After snow removal	For damaged fixture.	- Remove any debris or left over parts. - Install a new fixture. See Installation . - Use a power broom to remove the snow near the fixture, if practical. - Follow the recommended snow removal techniques described in FAA AC 150/5200-23 to avoid or at least to reduce damage to the fixture.

4.3 Part replacement



CAUTION

Except for the optical head, all replacements must be done in the workshop. To remove the complete fixture, see § 4.4.

4.3.1 Part replacement - general procedure

1. Replace the part:

- Replace the complete optical head See [Part replacement - complete optical head](#) .
- Replace the optical cover. See [Part replacement - optical cover](#) .
- Replace the optical kit. See [Part replacement - optical kit](#) .
- Arctic kit (arctic kit option). See [Part replacement - arctic kit \(arctic kit option\)](#) .
- Replace the Body. See [Part replacement - body](#) .
- Cooling block. See [Part replacement - cooling block](#).
- Body support assembly. See [Part replacement - body support assembly](#) .
- Cable lead, Earthing wire and cable strain relief bushing. See [Part replacement - cable lead, Earthing wire and cable bushing](#) .
- Frangible coupling. See [Part replacement - frangible coupling or column](#) .

- Repair a faulty light (monitoring option). See [Repair a faulty light \(monitoring option\)](#).
 - Replace the fuse resistor (monitoring option). See [Part replacement - fuse resistor \(monitoring option\)](#).
2. Prepare for field replacements.
- Assemble the complete optical head. See [Assemble the complete optical head](#).

4.3.2 Part replacement - complete optical head



Note

The replacement of the complete optical head can be done in the field.

Parts: see [Exploded view](#).

- Complete optical head, constituted of the following components See [Assemble the complete optical head](#).
 - Body
 - Optical kit
 - LED MCPCB screws
 - Optical cover
 - Cover fixation clip
 - Optical cover gasket
 - Cooling block
 - Cooling block gasket
 - Flat washers
- Body gasket

Remove

1. Remove the safety pins (A): I.
2. Open the body support clip (B): II to IV.
3. Carefully remove the complete optical head (C).
4. Disconnect the cable leads and the earthing wire, if it is connected (D).



WARNING

Before you disconnect the wires, earth the complete optical head.

5. Remove the body gasket (E).
6. Dispose of the body gasket.

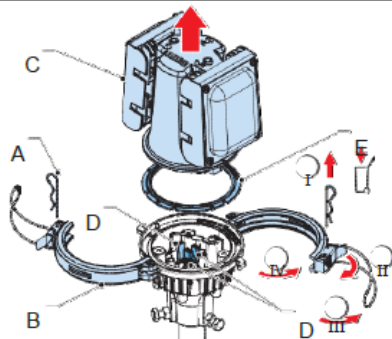

Prepare to install

1. Make sure that all the parts are clean.
2. Pay special attention to the parts where the gasket must fit.
3. Assemble the complete optical head. See [Assemble the complete optical head](#).

Install - Step 1

1. Install the new gasket (A). Make sure that the side marked 'THIS SIDE TO CENTER LINE' is at the side that corresponds with the arrow on the optical head.
2. Connect the cable leads to the connectors (B): 'IN1' and 'IN2'.
3. If you use an Earthing wire, connect it to the connector (C): 'PE'.

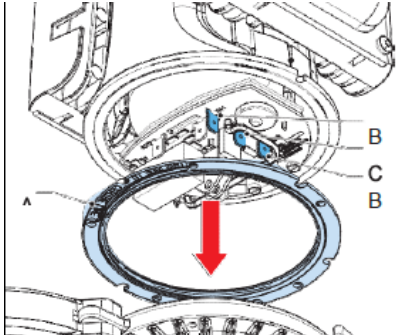

Install - Step 2

1. Put the complete optical head (A) on the support (B).
2. Make sure that the rims (C) fit into the gaps (D).
3. Make sure that the arrow (E) points to the center of the runway.
4. Close the clamps (F) of the body support clip: I to III. Make sure that the rim (G) of the optical head is completely inside the rims of the body support clip.

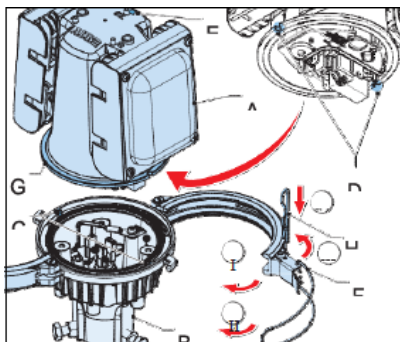

WARNING

The body support clip must tighten the optical head to avoid risk of FOD caused by a loose head assembly.

5. Install the safety pins (H): IV.
 6. Verify that the light turns on when powered.
-



CAUTION

Do not damage the cable lead.

4.3.3 Part replacement - optical cover

Parts: See [Exploded view](#).

- Optical cover
- Clip for optical cover
- Optical cover gasket

Tools:

- Screwdriver, Torx T20

Remove

1. Remove the screws for the optical cover clip and washers (A).
2. Remove the clip (B).
3. Remove the spacer (C).
4. Remove the optical cover (D).
5. Remove the optical cover gasket (E).
6. Dispose of the optical kit screws and washers.
7. Dispose of the optical cover gasket.

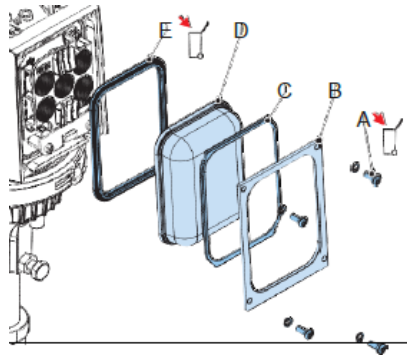

Install - Step 1

1. Make sure that all the parts are clean.
Pay extra attention to the parts where the optical cover gasket must fit.
2. Install the new optical cover gasket (A) onto the new optical cover (B).

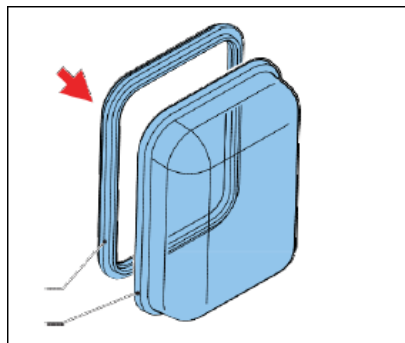

CAUTION

Make sure that the bulges of the optical cover gasket fit smoothly into the grooves of the cooling block and the grooves of the optical cover. The optical cover gasket is not symmetrical.

3. Install the new optical cover.
4. Make sure that the color of the optical cover matches the color of the sticker on the LED MCPCB. Exception: the ICAO threshold has a transparent cover.

Install - Step 2

1. Keep the optical cover (A) pressed against the head assembly (B).

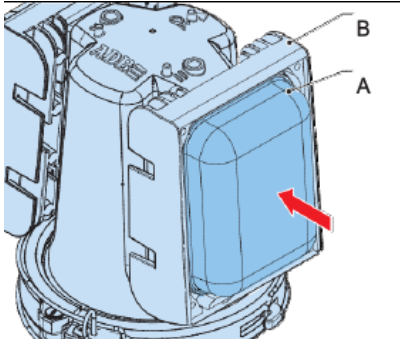

Install - Step 3

1. Install the spacer (A) and the clip (B).



CAUTION

If the fixture or the new clip has been supplied with a spacer (and always for fixtures with glass covers), do not forget to re-install the spacer between the cover and the clip.

2. Make sure that the smaller side of the spacer is on top.



CAUTION

The spacer is not rectangular. Install the spacer correctly.

3. Install the washers and the screws for the optical cover clip (C). See [Screws and torques](#) (torque).

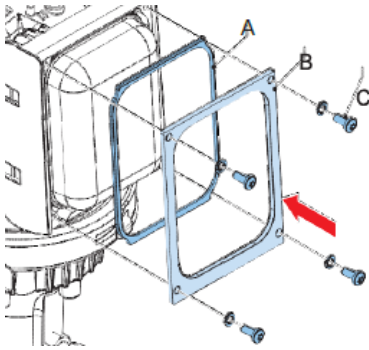

4.3.4 Part replacement - optical kit

Parts: see [Exploded view](#).

- Optical kit:
 - LED MCPCB
 - Optical block
 - Protection rings
- Optical cover gasket
- Body gasket



CAUTION

The cooling block for the FAA L-862E green differs from the cooling block used for all other applications. If you modify a fixture into or from FAA L-862E green from or into another function, also change the cooling block.



Note

The LED MCPCB and the optical block are supplied as a kit, complete with all components for replacement i.e. screws.

Tools:

- Screwdriver, Torx T20

Prepare

1. Do not mix optical blocks and LED MCPCBs from different deliveries. The optical blocks can change due to the future evolution of the available LEDs.

Remove - Step 1

1. Remove the complete optical head. See [Part replacement - complete optical head](#) .
2. Put the complete optical head on a clean surface.
3. Make sure that the complete optical head is earthed.

4. Connect the earth to the connector (A): PE. *The PCBs will discharge.*
5. Remove the optical cover. See [Part replacement - optical cover](#) .

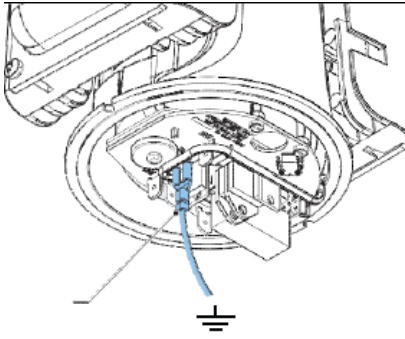

Remove - Step 2

1. Remove the optical block screws (A) and washers (B).
2. Dispose of the screws and the washers.
3. Remove the optical block (C).
4. Dispose of the optical block.
5. Remove the protection rings (D), if present.
6. Dispose of the protection rings.

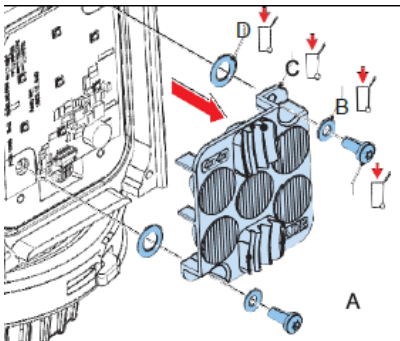

Remove - Step 3

1. Disconnect the connector (A).
2. Remove the LED MCPCB (B).
3. Dispose of the LED MCPCB.

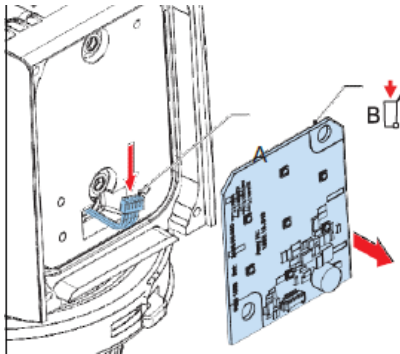

Install - Step 1

1. Read the instructions supplied with the parts for the correct installation of the new parts on the cooling block.



CAUTION

Do not touch the LEDs.

2. Make sure that all the parts are clean.
3. Make sure that the rear side of the new LED MCPCB (A) is clean. *The heat dissipation must be maximized.*
4. Put the LED MCPCB tightly against the cooling block (B). *The heat dissipation must be maximized.*
5. Connect the connector (C).

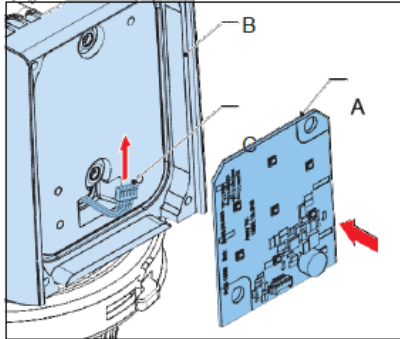

Note

- On one side there is an additional connector. This connector is used for service and diagnostic and is marked with a black dot. Do not connect the LED MCPCB to the connector with the black dot.
- On fixtures with an arctic kit there is an additional connector for the connection of the arctic kit. This connector has 4 poles. Connect the cable with the connector with 5 poles to the LED MCPCB.

Install - Step 2

1. Install the new protection rings (A), only if protection rings are delivered with the new optical kit.
2. Install the new optical block (B).
3. Make sure that the feet of the optical block fit in the cutouts of the LED MCPCB.
4. Install the new washers (C) and the new optical block screws (D). See [Screws and torques](#) (torque).
5. Install the optical cover. See [Part replacement - optical cover](#) .

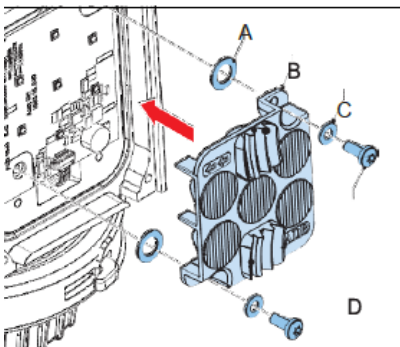

4.3.5 Part replacement - arctic kit (arctic kit option)

Parts: See [Exploded view](#).

- Arctic kit, including spacers and screws
- Optical cover gasket
- Body gasket



Note

The arctic kit is supplied as a kit, complete with all components for replacement i.e. screws.

Tools:

- Screwdriver, cross

Remove - Step 1

1. Remove the complete optical head. See [Part replacement - complete optical head](#) .
2. Put the complete optical head on a clean surface.
3. Make sure that the complete optical head is earthed. Connect the earth to the connector (A): PE. *The PCBs will discharge.*
4. Remove the optical cover. See [Part replacement - optical cover](#) .

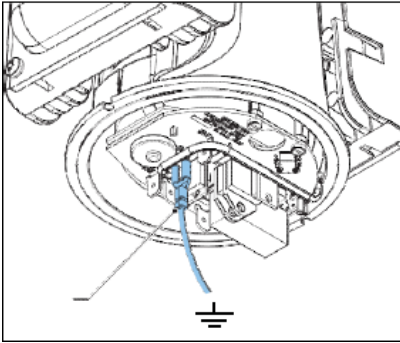

Remove - Step 2

1. Disconnect the connector (A).
2. Remove the arctic kit screws (B).
3. Remove the PCB of the arctic kit (C).
4. Remove the spacers (D).
5. Dispose of these parts:
 - a. arctic kit screws
 - b. PCB of the arctic kit
 - c. spacers

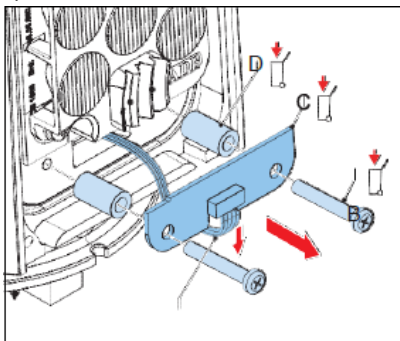

Install

1. Apply adhesive on the first three threads of the threaded holes of the cooling block. Use adhesive D. See § [Options and accessories](#).
2. Install the new spacers (A).
3. Install the new PCB of the arctic kit (B).

4. Install the new arctic kit screws (C). See [Screws and torques](#) (torque).
5. Connect the cable with 4 poles to connector (D).



Note

There are one or two additional connector(s) for the connection of the LED MCPCB and for service and diagnostic. Those connectors have 5 poles.

6. Install the optical cover. See [Part replacement - optical cover](#) .
7. Install the complete optical head. See [Part replacement - complete optical head](#) .

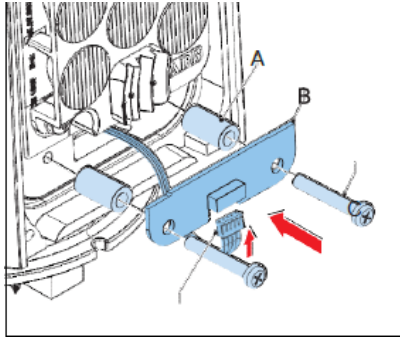

4.3.6 Part replacement - body

Parts: See [Exploded view](#).

- Body
- Optical cover gasket
- LED MCPCB screws
- Body gasket
- Cooling block gasket

Tools:

- Screwdriver, Torx T25

Remove

1. Remove the complete optical head. See [Part replacement - complete optical head](#) .
2. Put the complete optical head on a clean surface.
3. Make sure that the complete optical head is earthed. Connect the earth to the connector (A): PE. *The PCBs will discharge.*
4. Remove the optical cover. See [Part replacement - optical cover](#) .
5. Remove the optical kit. See [Part replacement - optical kit](#) .
6. Remove the cooling block. See [Part replacement - cooling block](#).

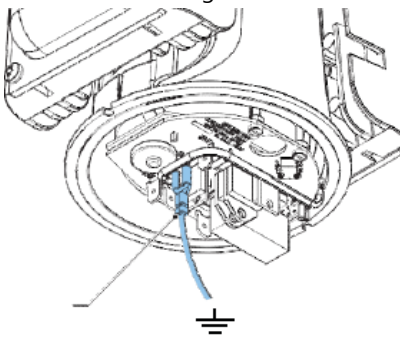

Install

1. Install the cooling block on the new body. See [Part replacement - cooling block](#).
2. Install the optical kit on the cooling block. See [Part replacement - optical kit](#).
3. Install the optical cover. See [Part replacement - optical cover](#).
4. Install the complete optical head. See [Part replacement - complete optical head](#)

4.3.7 Part replacement - cooling block

Parts: See [Exploded view](#).

- Cooling block
- Cooling block gasket
- Optical cover gasket

Tools:

- Screwdriver, Torx T25

Remove - Step 1

1. Remove the complete optical head. See [Part replacement - complete optical head](#).
2. Put the complete optical head on a clean surface.
3. Make sure that the complete optical head is earthed. Connect the earth to the connector (A): PE. *The PCBs will discharge.*
4. Remove the optical cover. See [Part replacement - optical cover](#).
5. Remove the optical kit. See [Part replacement - optical kit](#).

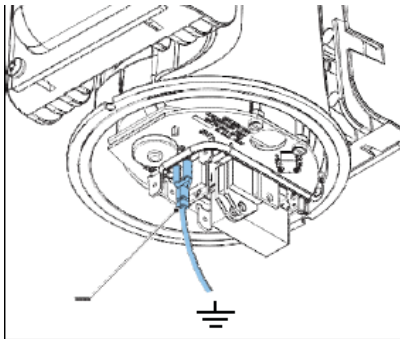

Remove - Step 2

1. Remove the cooling block screws (A) and washers (B).
2. Dispose of the cooling block screws and washers.
3. Remove the cooling block (C).
4. Remove the cooling block gasket (D).
5. Dispose of the cooling block gasket.

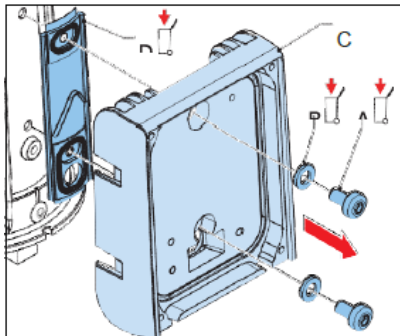

Install - Step 1

1. Make sure that all the parts are clean. Pay extra attention to the parts where the cooling block gasket must fit.
2. Apply adhesive on the first three threads of the threaded holes in the body. Use adhesive C. See [Options and accessories](#).
3. Install the new cooling block gasket (A) on the body (B).
4. Install the new cooling block (C).
5. Push the cooling block towards the arrow to the center line (D).
6. Install the washers (E) and the cooling block screws (F). See [Screws and torques](#) (torque).
7. Make sure that the cooling blocks on both sides of the fixture are parallel to each other.

Install - Step 2

1. Install the optical kit. See [Part replacement - optical kit](#) .
2. Install the optical cover. See [Part replacement - optical cover](#) .
3. Install the complete optical head. See [Part replacement - complete optical head](#)

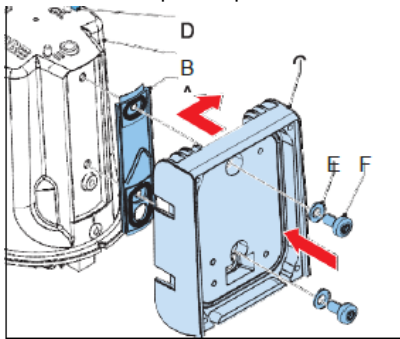

4.3.8 Part replacement - body support assembly

Parts: See [Exploded view](#).

- Body support assembly
- Body gasket

Tools:

- Spanner, size 13

Remove

1. Remove the complete optical head. See [Part replacement - complete optical head](#) .
2. Remove the alignment screws (A).
3. Remove the body support assembly (B).
4. If necessary, remove the cable lead, the Earthing wire and de cable strain relief bushing. See [Part replacement - cable lead, Earthing wire and cable bushing](#) .

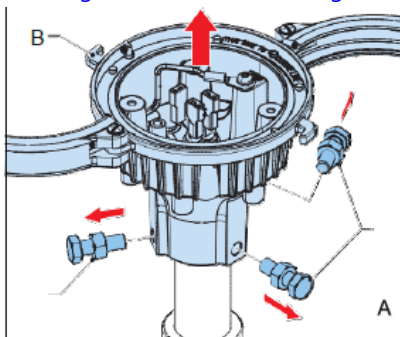

Install

1. If necessary, install the cable lead, the Earthing wire and the cable strain relief bushing. See [Part replacement - cable lead, Earthing wire and cable bushing](#) .
2. Install the new body support assembly (A).
3. Install but do not tighten the alignment screws (B).
4. Install the complete optical head. See [Part replacement - complete optical head](#) .

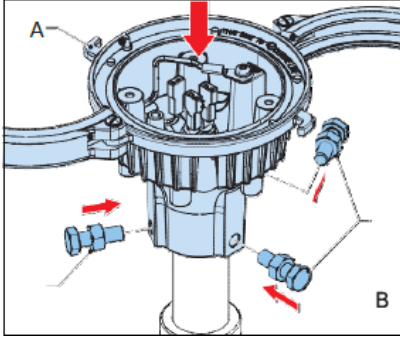

4.3.9 Part replacement - cable lead, Earthing wire and cable bushing

Parts: See [Exploded view](#).

- Body gasket
- Cable lead
- Earthing cable
- Cable strain relief bushing

Tools:

- Pliers
- Screwdriver, Torx T20



Note

The steps for the Earthing cable only apply if one is installed.

Remove - step 1

1. Remove the complete optical head. See [Part replacement - complete optical head](#) .
2. Compress the cable strain relief bushing (A) and pull it out of the body support (B). *Use the pliers.*
3. Remove the screw (C) for the Earthing cable.

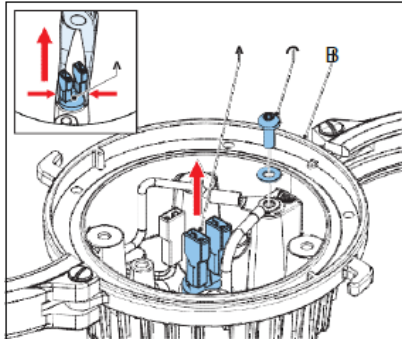

Remove - step 2

1. Open the cable strain relief bushing (A).
2. Pull the cable lead (C) and the Earthing wire (B) out of the fixture.
3. Dispose of the damaged parts.

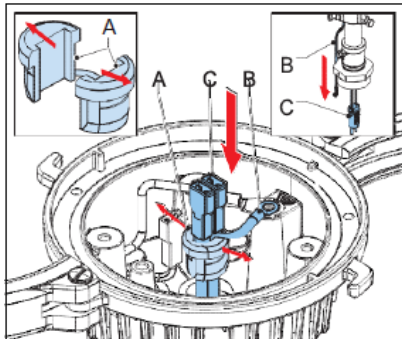

Install

1. Pull the cable lead (A) and the Earthing cable (B) through the hole (C) of the body support.
2. Put the cable lead and the Earthing cable in the cable strain relief bushing (D): I.
3. Install the Earthing cable on the screw for the Earthing cable (E).
4. Install the screw for the Earthing cable. See [Screws and torques](#) (torque).

- Compress the cable strain relief bushing and insert it in the hole of the body support : II. *Use the pliers.*
- Install the complete optical head. See [Part replacement - complete optical head](#) .

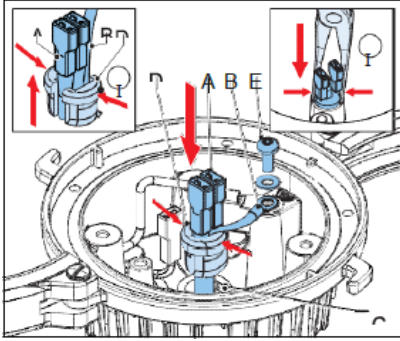

4.3.10 Part replacement - frangible coupling or column

Parts: See [Exploded view](#).

- Frangible coupling
- Column

Tools:

- Open spanner, size 11
- Alignment tool

Remove the frangible coupling

- Loosen the nut (A).
- Loosen the screw (B).
- Loosen the alignment screws (C).
- Remove the frangible coupling (D).
- Remove the column (E).

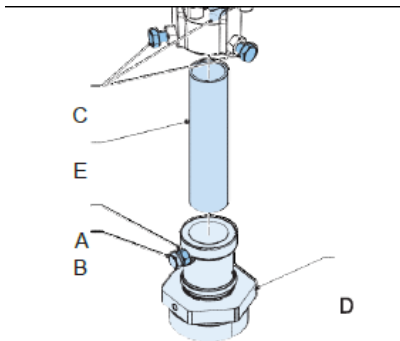

Install

- Install the new frangible coupling.
- Install the column.
- Tighten the screw (A) and the nut (B). See [Screws and torques](#) (torque).
- Install but do not tighten the alignment screws (C) and the nuts (D).

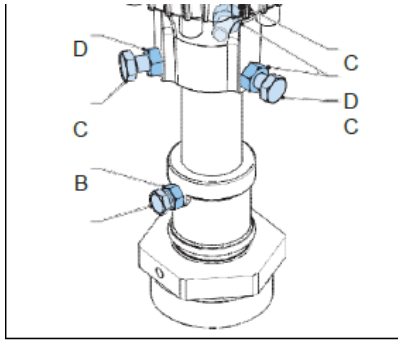

4.3.11 Repair a faulty light (monitoring option)

Parts: See [Exploded view](#).

- Optical kit

Replace

1. Remove the complete optical head. See [Part replacement - complete optical head](#) .
2. Replace both optical kits. See [Part replacement - optical kit](#) .
3. Replace the fuse resistor. See [Part replacement - fuse resistor \(monitoring option\)](#).
4. Connect the LED MCPCBs.

Connect

1. Perform a fixture operation test. See [Fixture operation test](#) .
2. If the fixture does not come on:
 - a. Replace the complete optical head. See [Part replacement - complete optical head](#) .
 - b. Perform an operation test. See [Fixture operation test](#)
 - c. If the fixture does not come on, contact ADB SAFEGATE

Assemble

1. Reinstall the complete optical head. See [Part replacement - complete optical head](#) .

4.3.12 Part replacement - fuse resistor (monitoring option)

Parts: See [Exploded view](#).

- Fuse resistor kit

Tools:

- Pliers

Disassemble

1. Remove the complete optical head. See [Part replacement - complete optical head](#) .
2. Pull the legs of the fuse resistor (A) and remove it from the sockets.
3. Dispose of the old fuse resistor.

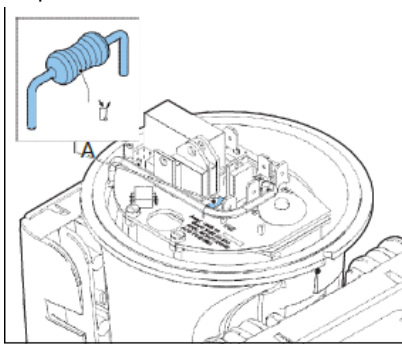

Assemble

1. Insert the legs of the new fuse resistor in the sockets.
2. Reinstall the complete optical head. See [Part replacement - complete optical head](#) .

4.3.13 Assemble the complete optical head

Parts: See [Exploded view](#).

- Body
- Optical kit
- LED MCPCB screws
- Optical cover
- Optical cover gasket
- Cooling block
- Cooling block washers
- Cooling block gasket
- Cooling block screws

Tools:

- Screwdriver, Torx T20 and T25

Install

1. Install the cooling block on the body. See [Part replacement - cooling block](#).
2. Install the optical kit on the cooling block. See [Part replacement - optical kit](#).
3. Install the optical cover. See [Part replacement - optical cover](#).

4.4 Fixture operation test

Tools

- FAA or IEC series isolation transformer, powered from a FAA or IEC constant current regulator
1. Connect the fixture directly to the transformer. Do not use a remote communication unit between the fixture and the transformer.
 2. Set the step of the constant current generator to 6.6 A.
 3. Check if the light works properly for 10 s.
 4. Turn OFF the constant current generator.
 5. If the fixture did not work or has switched off before the end of the test time, see [Troubleshooting guide](#).

5.0 RELIANCE EREL/ERES Troubleshooting

5.1 Operation Safety



CAUTION

Improper Operation

Do Not Operate this equipment other than as specified by the manufacturer

- Only qualified personnel, physically capable of operating the equipment and with no impairments in their judgment or reaction times, should operate this equipment.
- Read all system component manuals before operating this equipment. A thorough understanding of system components and their operation will help you operate the system safely and efficiently.
- Before starting this equipment, check all safety interlocks, fire-detection systems, and protective devices such as panels and covers. Make sure all devices are fully functional. Do not operate the system if these devices are not working properly. Do not deactivate or bypass automatic safety interlocks or locked-out electrical disconnects or pneumatic valves.
- Protect equipment with safety devices as specified by applicable safety regulations.
- If safety devices must be removed for installation, install them immediately after the work is completed and check them for proper functioning.
- Route electrical wiring along a protected path. Make sure they will not be damaged by moving equipment.
- Never operate equipment with a known malfunction.
- Do not attempt to operate or service electrical equipment if standing water is present.
- Use this equipment only in the environments for which it is rated. Do not operate this equipment in humid, flammable, or explosive environments unless it has been rated for safe operation in these environments.
- Never touch exposed electrical connections on equipment while the power is ON.

Failure to follow these instructions can result in equipment damage

5.2 Troubleshooting guide

Table 1: Troubleshooting guide

Problem	Possible cause	Possible solution
Only one side of the fixture has light output	The LED MCPCB has a malfunction	Replace the optical kit. See Part replacement - optical kit .
Both sides of the fixture have no light or light flickers	The connection to the series circuit has a malfunction.	Examine the electrical connection, the cable and the receptacles.
	The input power has a malfunction.	<ul style="list-style-type: none"> - Disconnect the plug from the secondary connection. - Test the series circuit with a spare fixture. - If the light is ok, replace the complete optical head. See Part replacement - complete optical head . - If the light is not ok, adjust the input power. - Troubleshoot the series circuit.
	Connection of the body assembly to the LED module has a malfunction.	<ul style="list-style-type: none"> - Remove the optical cover. See Part replacement - optical cover . - Check the electrical connection between the LED MCPCB and the body.
	The body assembly has a malfunction	Replace the body. See Part replacement - arctic kit (arctic kit option) .

Table 1: Troubleshooting guide (Continued)

Problem	Possible cause	Possible solution
Light output too low	The optical cover is dirty.	Clean the optical cover.
	The optical cover is defective.	Replace the optical cover. See Part replacement - optical cover .
	The LED MCPCB has a malfunction.	Replace the optical kit. See Part replacement - optical kit .

6.0 Parts and Technical data

Ordering Code

Elevated LED light

Application

RE = Runway Edge, Threshold End, Threshold⁵, End, and Stopway¹⁰

Cover

L = UV-resistant polycarbonate
S = Glass

Cable and Connectors

2 = 1 FAA L823 plug (2-pins)
6 = 1 plug (2-pins) w/Earth ground
8 = 1 external connected plug (2-pins)^{1,7}

Color Left Side

W = White
R = Red
G = Green^{3,4}
Y = Yellow
N = None (Obscured)

Color Right Side

W = White
R = Red
G = Green^{3,4}
Y = Yellow
N = None (Obscured)

Toe-in²

0 = No toe-in⁴
1 = Left side with toe-in
2 = Right side with toe-in
3 = Both sides with toe-in

Overall Fixture Height/Coupling

1 = 14 in (35.6 cm) with 1.5" coupling, 12 TPI
2 = 20 in (50.8 cm) with 1.5" coupling, 12 TPI
3 = 24 in (61.0 cm) with 1.5" coupling, 12 TPI
4 = 30 in (76.2 cm) with 1.5" coupling, 12 TPI
5 = 14 in (35.6 cm) with 2" coupling, 11.5 TPI
6 = 20 in (50.8 cm) with 2" coupling, 11.5 TPI
7 = 24 in (61.0 cm) with 2" coupling, 11.5 TPI
8 = 30 in (76.2 cm) with 2" coupling, 11.5 TPI
9 = 14 in (35.6 cm) OAH with 2" coupling, 11TPI^{1,2}

E R E X X X X X X X X X X 0 2

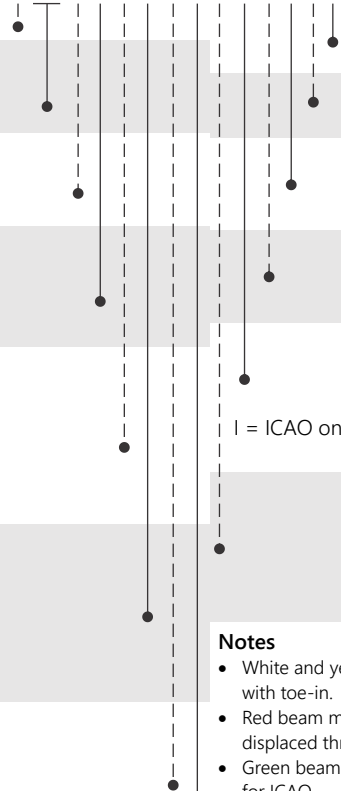

Version

2 = Improved mechanics

Enhanced Corrosion Resistance

0 = Included

Arctic Kit

0 = W/out arctic kit
1 = With arctic kit⁹

Options

0 = No option
1 = With bracket for snow rod

Standard

0 = ICAO- and FAA-compliant⁶

F = FAA only (for threshold application only)

I = ICAO only (for threshold/end and threshold application only)⁴

K = Australian (color to MOS 139)

Power Supply and Monitoring

S = 6.6A - 50/60Hz series supply, w/out monitoring

M = 6.6A - 50/60Hz series supply, with monitoring

P = IQ0 version⁸

Q = IQ1 version⁸

Notes

- White and yellow beams are for runway edge application and are always with toe-in.
 - Red beam may be with toe-in for runway edge application (e.g. displaced threshold) or without toe-in for runway end application.
 - Green beam is always with toe-in for FAA applications. See note 4 below for ICAO.
- 1 Not defined by FAA, hence not ETL Certified.
 - 2 See Toe-in Coding diagram for more information.
 - 3 G-green will only be delivered if Standard = K. All other applications will be delivered with F-green (ICAO/FAA).
 - 4 ICAO/TP312 unidirectional threshold light is always without toe-in.
 - 5 Code for an ICAO unidirectional threshold light is EREXXGN0XXIXXXX, where X must be selected according to the table.
 - 6 All lights without green beam are compliant to ICAO and FAA. Use 0 for any application (FAA, ICAO, TP312) that does not use green.
 - 7 Cord set connected external to column.
 - 8 The IQ functionality allows control and monitoring of the fixture. IQ1 fixtures are pre-configured for the specific position at delivery. This function is disabled in IQ0 fixtures but could be enabled later.
 - 9 Not with IQ fixtures.
 - 10 ICAO Stopway is always unidirectional, red and with toe-in.

6.1 Exploded view

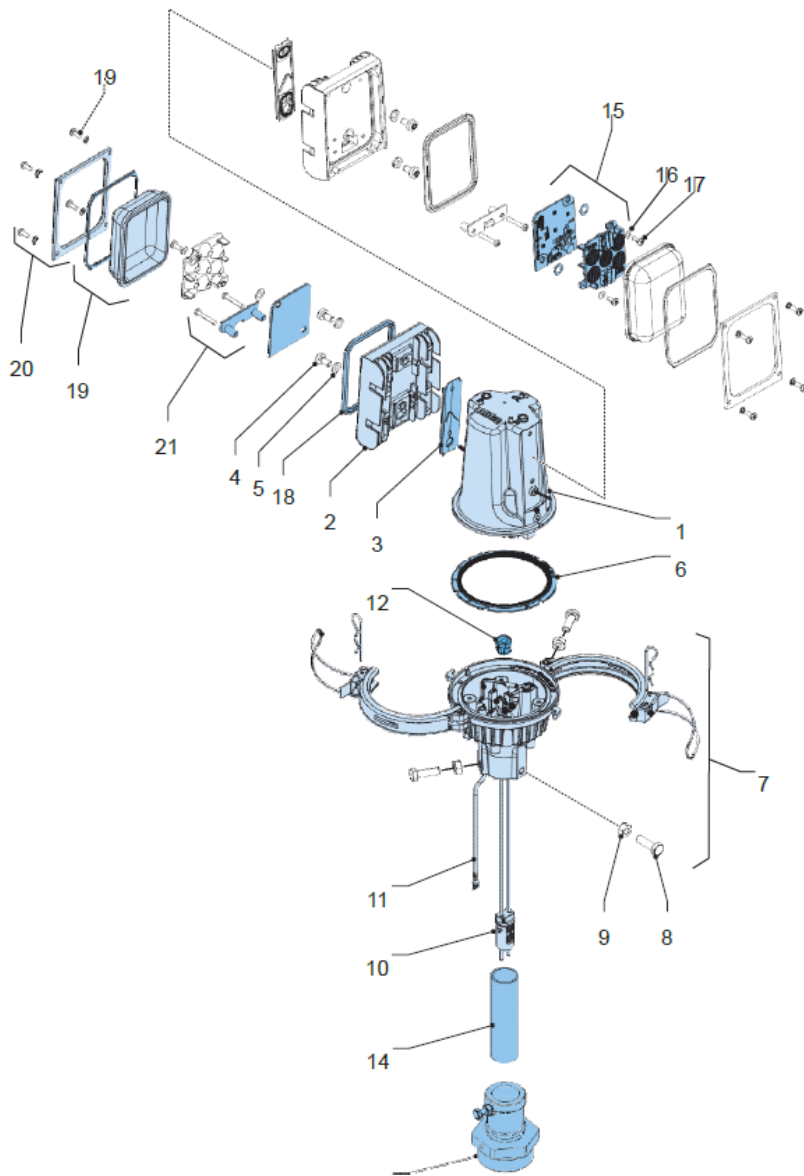

6.2 EREL/ERES Parts

	Components	Versions	Part number
1	Body - with arctic kit	Without monitoring option	4072.60.320
		With monitoring option	4072.60.330
2	Cooling block	all versions except FAA L-862E green and except ICAO threshold/end green with toe-in left and right	4072.56.060
		FAA L-862E green	4072.66.200
		THR side of bidirectional ICAO THR/END fixture (right toe in)	4072.66.150
		THR side of bidirectional ICAO THR/END fixture (left toe in)	4072.66.160
3	Cooling block gasket		4072.28.240
4	Cooling block screws		7125.00.700
5	Flat washer to cooling block		7283.04.470
6	Body gasket		MS00012-000-02
7	Body support assembly , complete with clips, safety pins and alignment screws		1406.00.666
8	Alignment screw M8x25 A2		7100.08.655
9	M8 nut for alignment screw		65A0524/08
10	Cable lead	for 14" OAH light	1458.03.775
		for 20" OAH light	1458.03.776
		for 24" OAH light	1458.03.777
		for 30" OAH light	1458.03.778
11	Earthing cable	for 14" OAH light	6100.40.010
		for 20" OAH light	6100.40.020
		for 24" OAH light	6100.40.030
		for 30" OAH light	6100.40.050
12	Cable strain relief bushing		6126.83.590
13	Frangible coupling	1.5" 12 TPI thread, 14-24" OAH	SP.4072.65.550
		1.5" 12 TPI thread, 30" OAH	SP.4072.65.560
		2" 11.5 TPI thread, 14-24" OAH	SP.4072.65.580
		2" 11.5 TPI thread, 30" OAH	SP.4072.65.610
		2" 11 TPI thread, 14-24" OAH	SP.4072.65.570
		2" 11 TPI thread, 30" OAH	SP.4072.65.600
14	1" column	for 14" OAH light	62A0007/6
		for 20" OAH light	62A0007/12
		for 24" OAH light	62A0007/16
		for 30" OAH light	62A0007/22
15	Optical kit	See the table 'Optical components' below	
	Dummy LED board (for the blank side of unidirectional lights) (not shown in exploded view)		1590.03.790P
16	Flat washer M4 Inox - DIN125		7283.04.230
17	Optical kit screw M4x10 A2+Loc2245		7100.10.101

	Components	Versions	Part number
18	Optical cover gasket		4072.28.180
19	Optical cover (including spacer, screws and washers)	See the table 'Optical components' below	
20	Clip for optical cover (kit containing one clip, screws and washers)		1406.00.670
21	Arctic kit (kit containing one heater, two spacers and screws)		1406.00.680
	Fuse resistor kit (20 resistors)	For fixtures with monitoring option	6132.00.250

Table 2: Optical components

Application	Color	Optical kit including the LED MCPCB and the optical block	Optical cover (glass) ¹	Optical cover (synthetic) ¹
ICAO runway edge and FAA L-862	White	1406.00.600	4072.28.165	4072.28.190
	Red	1406.00.610	4072.28.167	4072.28.192
	Yellow	1406.00.620	4072.28.168	4072.28.193
FAA L-862 and FAA L862E	Green	1406.00.630	4072.28.166	4072.28.191
ICAO runway end and FAA L-862E	Red	1406.00.640	4072.28.167	4072.28.192
ICAO threshold	Green	1406.00.650	4072.28.165	4072.28.190
MOS139 threshold	Green	1406.00.690	4072.28.165	4072.28.190

Notes

¹ Except for ICAO and MOS139 threshold, all fixtures are equipped with a colored optical cover for daytime recognition.

ICAO and MOS139 threshold fixtures are equipped with a transparent optical cover. Use the code of the white lens even if this application emits green light.

6.3 Screws and torques

Name	Screw type	Quantity on a fixture	Torque (in-lbs)
Screw for the earthing cable	M4x10 A2-taptite	1	22
Alignment screw	M8x25 A2	3	70-75
Cooling block screw	M6x12	4 (2 on each side)	40
Optical block screw	M4x10 A2+loc2245	4 (2 on each side)	11.5
Screws of the optical cover clip	M4x10 A2+loc2245	8 (2 on each side)	22
Arctic kit screws	Plastic screw M4x25	4 (2 on each side)	2.75
Screw to connect the frangible coupling to the column	M8x25	2	70-75

6.4 Options and accessories

You can buy these parts separately.

	Details	Article number
A	Alignment tool	1408.35.130
B	Snow rod (note: the light must be equipped with the optional bracket - see Fixture code schema .)	4072.28.670
C	Loctite 243	7870.05.160
D	Permabond A130	7870.00.800

Appendix A: SUPPORT

Our experienced engineers are available for support and service at all times, 24 hour/7 days a week. They are part of a dynamic organization making sure the entire ADB SAFEGATE is committed to minimal disturbance for airport operations.

ADB SAFEGATE Support

Live Technical Support - Americas

If at any time you have a question or concern about your product, just contact ADB SAFEGATE's technical service department. Trained in all areas of system issues, troubleshooting, quality control and technical assistance, our highly experienced Technical support specialists are available 24 hours a day, seven days a week to provide assistance over the phone.

ADB SAFEGATE **Americas Technical Service & Support (US & Canada): +1-800-545-4157**

ADB SAFEGATE Americas Technical Service & Support (International): +1-614-861-1304

During regular business hours, you can also Chat with a Service Technician. We look forward to working with you!

Before You Call

When you have an airfield lighting or system control system problem it is our goal to support airfield maintenance staff as quickly as possible. To support this effort we ask that you have the following information ready before calling.

- The *airport code*
- If not with an airport, then company name (prefer customer id number)
- Contact phone number and email address
- Product with part number preferable or product number
- Have you reviewed the product's manual and troubleshooting guide
- Do you have a *True RMS* meter available (and any other necessary tools)
- Be located with the product ready to troubleshoot

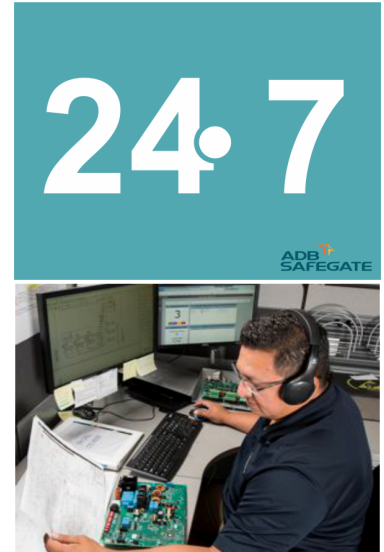

Note

For more information, see www.adbsafegate.com, or contact ADB SAFEGATE Support via email at support@adbsafegate.com or

Brussels: +32 2 722 17 11

Rest of Europe: +46 (0) 40 699 17 40

Americas: +1 614 861 1304. Press 3 for technical service or press 4 for sales support.

China: +86 (10) 8476 0106

A.1 ADB SAFEGATE Website

The ADB SAFEGATE website, www.adbsafegate.com, offers information regarding our airport solutions, products, company, news, links, downloads, references, contacts and more.

A.2 Recycling

A.2.1 Local Authority Recycling

The disposal of ADB SAFEGATE products is to be made at an applicable collection point for the recycling of electrical and electronic equipment. The correct disposal of equipment prevents any potential negative consequences for the environment and human health, which could otherwise be caused by inappropriate waste handling. The recycling of materials helps to conserve natural resources. For more detailed information about recycling of products, contact your local authority city office.

A.2.2 ADB SAFEGATE Recycling

ADB SAFEGATE is fully committed to environmentally-conscious manufacturing with strict monitoring of our own processes as well as supplier components and sub-contractor operations. ADB SAFEGATE offers a recycling program for our products to all customers worldwide, whether or not the products were sold within the EU.

ADB SAFEGATE products and/or specific electrical and electronic component parts which are fully removed/separated from any customer equipment and returned will be accepted for our recycling program.

All items returned must be clearly labelled as follows:

- For *ROHS/WEEE* Recycling
- Sender contact information (Name, Business Address, Phone number).
- Main Unit Serial Number.

ADB SAFEGATE will continue to monitor and update according for any future requirements for *EU directives* as and when *EU member states* implement new *regulations* and or *amendments*. It is our aim to maintain our *compliance plan* and assist our customers.

Company Addresses

<p>ADB SAFEGATE</p>	<p>ADB SAFEGATE, Belgium: Leuvensesteenweg 585, B-1930 Zaventem Belgium</p>
<p>Contact: Tel.: +32 2 722 17 11, Fax: +32 2 722 17 64</p>	<p>Email: marketing@adbsafegate.com Internet: www.adbsafegate.com</p>
<p>Americas LLC</p>	<p>ADB SAFEGATE, Americas: 977 Gahanna Parkway, Columbus, OH 43230 USA</p>
<p>Contact: Tel.: +1 (614) 861 1304, Fax: +1 (614) 864 2069</p>	<p>Email: sales.us@adbsafegate.com Internet: www.adbsafegate.com</p>
<p>ADB SAFEGATE Sweden AB</p>	<p>ADB SAFEGATE, Sweden: Djurhagegatan 19 SE-213 76 Malmö Sweden</p>
<p>Contact: Tel.: +46 (0)40 699 17 00, Fax: +46 (0)40 699 17 30</p>	<p>Email: marketing@adbsafegate.com Internet: www.adbsafegate.com</p>
<p>ADB SAFEGATE Airfield Technologies Ltd. China</p>	<p>ADB SAFEGATE, China: Unit 603, D Block, CAMIC International Convention Center, No 3, Hua Jia Di East road, ChaoYang district, Beijing 100102 P.R. China</p>
<p>Contact: Tel.: +86 (10) 8476 0106, Fax: +86 (10) 8476 0090</p>	<p>Email: china@safegate.com Internet: www.adbsafegate.com</p>
<p>ADB SAFEGATE Germany GmbH</p>	<p>ADB SAFEGATE Germany GmbH, Mannheim: Konrad-Zuse-Ring 6, D-68163 Mannheim Germany</p>
<p>Contact: Tel.: +49 (621) 87 55 76-0, Fax: +49 (621) 87 55 76-55</p>	<p>Email: marketing@adbsafegate.com Internet: www.adbsafegate.com</p>

The logo for ADB SAFEGATE, featuring the text "ADB SAFEGATE" in a bold, blue, sans-serif font. Above the letter "A" in "ADB" is a stylized orange and yellow starburst icon.

**Powering Your Airport Performance
from Approach to Departure**

adbsafegate.com

Copyright © ADB SAFEGATE, all rights reserved

The ADB SAFEGATE logo, identical to the one in the top left corner, positioned in the bottom right corner of the page. It features the text "ADB SAFEGATE" in blue with the orange and yellow starburst icon above the "A".