

L-880 and L-881 PAPI, Style A
Precision Approach Path Indicator (Voltage Powered)

User Manual

96A0209, Rev. AK, 2023/02/02



A.0 Disclaimer / Standard Warranty

CE certification

The equipment listed as CE certified means that the product complies with the essential requirements concerning safety and hygiene. The European directives that have been taken into consideration in the design are available on written request to ADB SAFEGATE.

ETL certification

The equipment listed as ETL certified means that the product complies with the essential requirements concerning safety and FAA Airfield regulations. The FAA directives that have been taken into consideration in the design are available on written request to ADB SAFEGATE.

All Products Guarantee

ADB SAFEGATE will correct by repair or replacement per the applicable guarantee above, at its option, equipment or parts which fail because of mechanical, electrical or physical defects, provided that the goods have been properly handled and stored prior to installation, properly installed and properly operated after installation, and provided further that Buyer gives ADB SAFEGATE written notice of such defects after delivery of the goods to Buyer. Refer to the Safety section for more information on Material Handling Precautions and Storage precautions that must be followed.

ADB SAFEGATE reserves the right to examine goods upon which a claim is made. Said goods must be presented in the same condition as when the defect therein was discovered. ADB SAFEGATE further reserves the right to require the return of such goods to establish any claim.

ADB SAFEGATE's obligation under this guarantee is limited to making repair or replacement within a reasonable time after receipt of such written notice and does not include any other costs such as the cost of removal of defective part, installation of repaired product, labor or consequential damages of any kind, the exclusive remedy being to require such new parts to be furnished.

ADB SAFEGATE's liability under no circumstances will exceed the contract price of goods claimed to be defective. Any returns under this guarantee are to be on a transportation charges prepaid basis. For products not manufactured by, but sold by ADB SAFEGATE, warranty is limited to that extended by the original manufacturer. This is ADB SAFEGATE's sole guarantee and warranty with respect to the goods; there are no express warranties or warranties of fitness for any particular purpose or any implied warranties of fitness for any particular purpose or any implied warranties other than those made expressly herein. All such warranties being expressly disclaimed.

Standard Products Guarantee

Products manufactured by ADB SAFEGATE are guaranteed against mechanical, electrical, and physical defects (excluding lamps) which may occur during proper and normal use for a period of two years from the date of ex-works delivery, and are guaranteed to be merchantable and fit for the ordinary purposes for which such products are made.



Note

See your applicable sales agreement for a complete warranty description.

Replaced or repaired equipment under warranty falls into the warranty of the original delivery. No new warranty period is started for these replaced or repaired products.

FAA Certified products manufactured by ADB SAFEGATE

ADB SAFEGATE L858 Airfield Guidance Signs are warranted against mechanical and physical defects in design or manufacture for a period of 2 years from date of installation, per FAA AC 150/5345-44 (applicable edition).

ADB SAFEGATE LED products (with the exception of obstruction lighting) are warranted against electrical defects in design or manufacture of the LED or LED specific circuitry for a period of 4 years from date of installation, per FAA EB67 (applicable edition). These FAA certified constant current (series) powered LED products must be installed, interfaced and powered with and through products certified under the FAA Airfield Lighting Equipment Program (ALECP) to be included in this 4 (four) year warranty. This includes, but is not limited to, interface with products such as Base Cans, Isolation Transformers, Connectors, Wiring, and Constant Current Regulators.



Note

See your sales order contract for a complete warranty description.

Replaced or repaired equipment under warranty falls into the warranty of the original delivery. No new warranty period is started for these replaced or repaired products.

Liability



WARNING

Use of the equipment in ways other than described in the catalog leaflet and the manual may result in personal injury, death, or property and equipment damage. Use this equipment only as described in the manual.

ADB SAFEGATE cannot be held responsible for injuries or damages resulting from non-standard, unintended uses of its equipment. The equipment is designed and intended only for the purpose described in the manual. Uses not described in the manual are considered unintended uses and may result in serious personal injury, death or property damage.

Unintended uses, includes the following actions:

- Making changes to equipment that have not been recommended or described in this manual or using parts that are not genuine ADB SAFEGATE replacement parts or accessories.
- Failing to make sure that auxiliary equipment complies with approval agency requirements, local codes, and all applicable safety standards if not in contradiction with the general rules.
- Using materials or auxiliary equipment that are inappropriate or incompatible with your ADB SAFEGATE equipment.
- Allowing unskilled personnel to perform any task on or with the equipment.

© ADB SAFEGATE SWEDEN AB

This manual or parts thereof may not be reproduced, stored in a retrieval system, or transmitted, in any form or by any means, electronic, mechanical, photocopying, recording, nor otherwise, without ADB SAFEGATE SWEDEN AB's prior written consent.

This manual could contain technical inaccuracies or typographical errors. ADB SAFEGATE SWEDEN AB reserves the right to revise this manual from time to time in the contents thereof without obligation of ADB SAFEGATE SWEDEN AB to notify any person of such revision or change. Details and values given in this manual are average values and have been compiled with care. They are not binding, however, and ADB SAFEGATE SWEDEN AB disclaims any liability for damages or detriments suffered as a result of reliance on the information given herein or the use of products, processes or equipment to which this manual refers. No warranty is made that the use of the information or of the products, processes or equipment to which this manual refers will not infringe any third party's patents or rights. The information given does not release the buyer from making their own experiments and tests.

© ADB SAFEGATE BV

This manual or parts thereof may not be reproduced, stored in a retrieval system, or transmitted, in any form or by any means, electronic, mechanical, photocopying, recording, nor otherwise, without ADB SAFEGATE BV's prior written consent.

This manual could contain technical inaccuracies or typographical errors. ADB SAFEGATE BV reserves the right to revise this manual from time to time in the contents thereof without obligation of ADB SAFEGATE BV to notify any person of such revision or change. Details and values given in this manual are average values and have been compiled with care. They are not binding, however, and ADB SAFEGATE BV disclaims any liability for damages or detriments suffered as a result of reliance on the information given herein or the use of products, processes or equipment to which this manual refers. No warranty is made that the use of the information or of the products, processes or equipment to which this manual refers will not infringe any third party's patents or rights. The information given does not release the buyer from making their own experiments and tests.

TABLE OF CONTENTS

1.0 Safety	1
1.1 Safety Messages	1
1.1.1 Introduction to Safety	2
1.1.2 Intended Use	2
1.1.3 Material Handling Precautions: Storage	3
1.1.4 Operation Safety	3
1.1.5 Maintenance Safety	3
2.0 L-880 & L-881 PAPI, Style A	5
2.1 About this manual	5
2.2 How to work with the manual	5
3.0 PAPI A Overview	7
3.1 Precision Approach Path Indicator	7
3.2 Type L-880 PAPI System	8
3.3 Type L-881 PAPI System	10
3.4 Type L-881 PAPI	10
3.5 PAPI Light Unit	11
3.5.1 Lamps	11
3.5.2 Reflector Panel	11
3.5.3 Filter Panel	11
3.5.4 Lens Panels	12
3.5.5 Lens Shield	12
3.5.6 Adjustable Mounting Legs	12
3.5.7 Tilt Switch	13
3.6 Theory of Operation	13
3.6.1 Master	13
3.6.2 Daytime Operation	13
3.6.3 Nighttime Operation	14
3.6.4 Remote/Local Operation	14
3.6.5 Light Unit	14
3.6.6 Optional Heater	14
3.6.7 Optional Interlock Relay	14
3.6.8 Tilt Switch	14
3.7 Style A L-880/L-881 PAPI: Required Equipment	14
3.8 Specifications	15
3.8.1 Lamps	15
3.8.2 Lamp Life	16
3.8.3 Transmission Factor of Red Sector	16
3.8.4 Transmission Sector	16
3.8.5 Visual Acquisition Range	16
3.8.6 Transient Suppression	16
3.8.7 Tilt Switch	16
3.8.8 Mean Time Between Failures	16
3.8.9 Environmental Operating Conditions	16
3.8.10 Mounting Provisions	16
3.8.11 Photometrics	16
3.9 Digital Protractor Specifications	17
3.9.1 Range	17
3.9.2 Resolution	17
3.9.3 Accuracy	17
3.9.4 Repeatability	17
3.9.5 Supply Voltage	17
3.9.6 Battery Life	17
3.9.7 Temperature	17
3.9.8 Weight	17

4.0 Installation	19
4.1 Unpacking	19
4.2 Instruments for Installation and Verification	19
4.2.1 Installation Using Bubble-Level Style Aiming Device	19
4.2.2 Bubble-Level Style Aiming Device	20
4.2.3 Installation Using Digital-Level Style Aiming Device	21
4.3 Siting Considerations	22
4.3.1 Distance of PAPI Units from Runway Edge	22
4.3.2 Lateral Spacing of PAPI Units	22
4.4 Siting PAPI with ILS Glideslope	23
4.5 Siting PAPI on Runways Without ILS	23
4.5.1 Threshold Crossing Height (TCH)	23
4.5.2 Glideslope Angle	23
4.5.3 Distance of PAPI from Threshold	23
4.5.4 Obstacle Clearance Surface	24
4.5.5 Reduction of Beam Coverage for Obstacle Avoidance	25
4.6 Siting Tolerances	25
4.6.1 Azimuthal Aiming	25
4.6.2 Mounting Height Tolerance	25
4.6.3 PAPI Tolerance Along Line Perpendicular to Runway	25
4.6.4 Correction for Runway Longitudinal Gradient	26
4.7 Additional Siting Considerations	27
4.8 PAPI Foundations	28
4.9 PAPI Aiming Angles	34
4.10 Assembling Adjustable Legs	35
4.11 Mounting Unit	35
4.12 Aligning Units	37
4.12.1 How Bubble-Level Aiming Device Works	38
4.12.2 How Digital-Level Aiming Device Works	38
4.13 Calibrating Digital Protractor	39
4.13.1 Performing Digital Protractor Accuracy Test	40
4.13.2 Performing Digital Protractor Calibration Procedure	41
4.13.3 Aligning PAPI Using Bubble-Level/Digital-Level Aiming Devices	44
4.14 Adjusting Rough Elevation Setting	45
4.14.1 Adjusting Rough Elevation Setting for Four-Leg PAPI System	45
4.14.2 Adjusting Rough Elevation Setting for Three-Leg PAPI System	46
4.14.3 Adjusting Rough Elevation Setting for Three-Leg PAPI System	46
4.15 Adjusting Fine Elevation Setting	46
4.15.1 Adjusting Fine Elevation Setting for Four-Leg PAPI System	46
4.15.2 Adjusting Fine Elevation Setting for Three-Leg PAPI System	47
4.16 Installing Master Box Assembly	47
4.16.1 Leveling Tilt Switches	48
4.17 Wiring between Masters and Light Units	48
4.17.1 Grounding Units	48
4.17.2 Connecting External Wiring	48
4.18 Checking Slope Angles of PAPI Units	50
4.19 Using Reference Bases for Checking Stick	51
4.19.1 Locating Reference Bases	51
4.19.2 Making Observations with Checking Stick	52
4.19.3 Making Flight Checks for Reduced Horizontal Coverage	52
5.0 Operation	53
5.1 Operating PAPI System	53
5.1.1 Normal Operation	53
5.1.2 Regions with Heavy Snowfall	53
5.1.3 Criteria for System Deactivation	53
5.1.4 Initial Startup Using Local Control	53
5.1.5 Remote Control Operation	54
5.1.6 Optional Interlock Relay	54
5.2 Operating Digital Protractor	54

6.0 Maintenance	57
6.1 Maintenance Schedule	57
6.2 Maintenance Procedures	58
6.2.1 Replacing Lamp	58
6.2.2 Replacing Objective Lens	59
6.2.3 Replacing Filters	59
6.2.4 Cleaning and Storing Digital Protractor	59
7.0 Troubleshooting	61
7.1 Troubleshooting	61
7.2 Wiring Schematics and Installation Drawings	63
8.0 PAPI A Parts	69
8.1 L-880/L-881 Style A Part Numbering System	69
8.2 Optical Box Final Assembly Parts List	70
8.3 Optical Assembly Parts List	71
8.4 PAPI Style A Master Box Assembly Parts List	73
8.5 PAPI Style A L-880 (4-Box) Field Splice Kit Parts List	76
8.6 PAPI Style A L-881 (2-Box) Field Splice Kit Parts List	77
8.7 PAPI Style A L-881 (2-Box) Field Splice Kit (Without Interlock Option) Parts List	77
8.8 Spare Parts	78
A.0 SUPPORT	79
A.1 ADB SAFEGATE Website	79
A.2 Recycling	80
A.2.1 Local Authority Recycling	80
A.2.2 ADB SAFEGATE Recycling	80

List of Figures

Figure 1: L-880 Four-Box System	7
Figure 2: L-881 Two-Box System	7
Figure 3: PAPI Obstacle Clearance Surface	8
Figure 4: L-880 Signal Display	9
Figure 5: L-881 Signal Display	10
Figure 6: PAPI Light Unit (3-Lamp)	11
Figure 7: PAPI Light Unit (2-Lamp)	11
Figure 8: Adjustable Mounting Legs	12
Figure 9: Master Component Panel	13
Figure 10: Checking Stick	20
Figure 11: Side View of Digital-Level Aiming Device for Two-Lamp PAPI	21
Figure 12: Top View of Digital-Level Aiming Device for Two-Lamp PAPI	22
Figure 13: Obstacle Clearance Surface	24
Figure 14: Correction for Runway Longitudinal Gradient	26
Figure 15: Relocating PAPI Units	27
Figure 16: Installation on Concrete Pad (Two-Lamp, Three-Leg PAPI)	28
Figure 17: Installation on Concrete Pad (Two-Lamp, Four-Leg PAPI)	29
Figure 18: Installation on Concrete Pad (Three-Lamp, Three-Leg PAPI)	30
Figure 19: Installation on Concrete Pad (Three-Lamp, Four-Leg PAPI)	31
Figure 20: Positioning Plate (Two Lamps/Three Legs)	32
Figure 21: Positioning Plate (Two Lamps/Four Legs)	32
Figure 22: Positioning Plate (Three Lamps/Three Legs)	33
Figure 23: Positioning Plate (Three Lamps/Four Legs)	33
Figure 24: Frangible Coupling	34
Figure 25: Elevation Setting Sequence (Two-Lamp, Four-Leg PAPI Shown)	36
Figure 26: Elevation Setting Sequence (Two-Lamp, Three-Leg PAPI Shown)	37
Figure 27: Positioning Digital Protractor	40
Figure 28: Rotating and Rolling Protractor	40
Figure 29: Digital Protractor Displays and Buttons	41
Figure 30: O within Flashing Brackets	41
Figure 31: Rotating and Rolling Digital Protractor for Horizontal Settings	42
Figure 32: Rotating and Rolling Digital Protractor for Vertical Settings	43
Figure 33: Digital Protractor Installation	44
Figure 34: Master Box Assembly	47
Figure 35: L-880/L-881 Master External Connections	49
Figure 36: L-880/L-881 Light Box External Connections	50

Figure 37: Checking Slope Angles	51
Figure 38: Digital Protractor Initial Angle Displayed	55
Figure 39: Filter	59
Figure 40: 43A2204-1	63
Figure 41: 43A2204	64
Figure 42: PAPI Installation, 117A0011 sht 1	65
Figure 43: PAPI Installation, 117A0011 sht 1	66
Figure 44: Two-Lamp PAPI Light Box Internal Wiring Schematic	67
Figure 45: Three-Lamp Light Box Internal Wiring Schematic	68
Figure 46: Optical Box Parts and Details	70
Figure 47: Optical Box Part Detail B-B	70
Figure 48: Optical Box Parts Detail C-C, E-E	71
Figure 49: Optical Box Side View	72
Figure 50: Master Box Assembly	73
Figure 51: Master Panel Assemblies	75

List of Tables

Table 1: L-880 PAPI Required Equipment Supplied	14
Table 2: L-881 PAPI Required Equipment Supplied	15
Table 3: Required Equipment Not Supplied	15
Table 4: Contractor-Supplied Connectors, Conduit, Cable, and Bushings	15
Table 5: Threshold Crossing Height	23
Table 6: Aiming Angles for L-880 PAPI Units	34
Table 7: Aiming Angles for L-881 PAPI Units	35
Table 8: Conversion from Decimal Degrees to Minutes	39
Table 9: Output Current	53
Table 10: PAPI Maintenance	57
Table 11: L-880/L-881 PAPI Troubleshooting	62
Table 12: L-880 PAPI System	69
Table 13: L-881 PAPI System	70
Table 14: Lamp Reflector Assembly Parts	71
Table 15: PAPI Style A Master Panel Assembly Parts List	73
Table 16: L-880/L-881 PAPI Style A Optical Box Final Assembly Parts List	76
Table 17: PAPI Style A L-880 (4-Box) Field Splice Kit (With Interlock Option) Parts List	76
Table 18: PAPI Style A L-880 (4-Box) Field Splice Kit (Without Interlock Option) Parts List	77
Table 19: PAPI Style A L-881 (2-Box) Field Splice Kit (With Interlock Option) Parts List	77
Table 20: PAPI Style A Aiming Device Kit Parts List	78
Table 21: PAPI A Spare Parts	78

1.0 Safety

Introduction to Safety







This section contains general safety instructions for installing and using ADB SAFEGATE equipment. Some safety instructions may not apply to the equipment in this manual. Task- and equipment-specific warnings are included in other sections of this manual where appropriate.

1.1 Safety Messages

HAZARD Icons used in the manual

For all HAZARD symbols in use, see the Safety section. All symbols must comply with ISO and ANSI standards.

Carefully read and observe all safety instructions in this manual, which alert you to safety hazards and conditions that may result in personal injury, death or property and equipment damage and are accompanied by the symbol shown below.

	<p>WARNING Failure to observe a warning may result in personal injury, death or equipment damage.</p>
	<p>DANGER - Risk of electrical shock or ARC FLASH Disconnect equipment from line voltage. Failure to observe this warning may result in personal injury, death, or equipment damage. ARC Flash may cause blindness, severe burns or death.</p>
	<p>WARNING - Wear personal protective equipment Failure to observe may result in serious injury.</p>
	<p>WARNING - Do not touch Failure to observe this warning may result in personal injury, death, or equipment damage.</p>
	<p>CAUTION Failure to observe a caution may result in equipment damage.</p>
	<p>ELECTROSTATIC SENSITIVE DEVICES This equipment may contain electrostatic devices.</p>

Qualified Personnel

	<p>Important Information The term qualified personnel is defined here as individuals who thoroughly understand the equipment and its safe operation, maintenance and repair. Qualified personnel are physically capable of performing the required tasks, familiar with all relevant safety rules and regulations and have been trained to safely install, operate, maintain and repair the equipment. It is the responsibility of the company operating this equipment to ensure that its personnel meet these requirements. Always use required personal protective equipment (PPE) and follow safe electrical work practice.</p>
---	---

1.1.1 Introduction to Safety



CAUTION

Unsafe Equipment Use

This equipment may contain electrostatic devices, hazardous voltages and sharp edges on components

- Read installation instructions in their entirety before starting installation.
- Become familiar with the general safety instructions in this section of the manual before installing, operating, maintaining or repairing this equipment.
- Read and carefully follow the instructions throughout this manual for performing specific tasks and working with specific equipment.
- Make this manual available to personnel installing, operating, maintaining or repairing this equipment.
- Follow all applicable safety procedures required by your company, industry standards and government or other regulatory agencies.
- Install all electrical connections to local code.
- Use only electrical wire of sufficient gauge and insulation to handle the rated current demand. All wiring must meet local codes.
- Route electrical wiring along a protected path. Make sure they will not be damaged by moving equipment.
- Protect components from damage, wear, and harsh environment conditions.
- Allow ample room for maintenance, panel accessibility, and cover removal.
- Protect equipment with safety devices as specified by applicable safety regulations
- If safety devices must be removed for installation, install them immediately after the work is completed and check them for proper functioning prior to returning power to the circuit.

Failure to follow this instruction can result in serious injury or equipment damage

Additional Reference Materials



Important Information

- IEC - International Standards and Conformity Assessment for all electrical, electronic and related technologies.
- IEC 60364 - Electrical Installations in Buildings.
- FAA Advisory: AC 150/5340-26 (current edition), Maintenance of Airport Visual Aid Facilities.
- Maintenance personnel must refer to the maintenance procedure described in the ICAO Airport Services Manual, Part 9.
- ANSI/NFPA 79, Electrical Standards for Metalworking Machine Tools.
- National and local electrical codes and standards.

1.1.2 Intended Use



CAUTION

Use this equipment as intended by the manufacturer

This equipment is designed to perform a specific function, do not use this equipment for other purposes

- Using this equipment in ways other than described in this manual may result in personal injury, death or property and equipment damage. Use this equipment only as described in this manual.

Failure to follow this instruction can result in serious injury or equipment damage

1.1.3 Material Handling Precautions: Storage



CAUTION

Improper Storage

Store this equipment properly

- If equipment is to be stored prior to installation, it must be protected from the weather and kept free of condensation and dust.

Failure to follow this instruction can result in equipment damage

1.1.4 Operation Safety



CAUTION

Improper Operation

Do Not Operate this equipment other than as specified by the manufacturer

- Only qualified personnel, physically capable of operating the equipment and with no impairments in their judgment or reaction times, should operate this equipment.
- Read all system component manuals before operating this equipment. A thorough understanding of system components and their operation will help you operate the system safely and efficiently.
- Before starting this equipment, check all safety interlocks, fire-detection systems, and protective devices such as panels and covers. Make sure all devices are fully functional. Do not operate the system if these devices are not working properly. Do not deactivate or bypass automatic safety interlocks or locked-out electrical disconnects or pneumatic valves.
- Protect equipment with safety devices as specified by applicable safety regulations.
- If safety devices must be removed for installation, install them immediately after the work is completed and check them for proper functioning.
- Route electrical wiring along a protected path. Make sure they will not be damaged by moving equipment.
- Never operate equipment with a known malfunction.
- Do not attempt to operate or service electrical equipment if standing water is present.
- Use this equipment only in the environments for which it is rated. Do not operate this equipment in humid, flammable, or explosive environments unless it has been rated for safe operation in these environments.
- Never touch exposed electrical connections on equipment while the power is ON.

Failure to follow these instructions can result in equipment damage

1.1.5 Maintenance Safety



DANGER

Electric Shock Hazard

This equipment may contain electrostatic devices

- Do not operate a system that contains malfunctioning components. If a component malfunctions, turn the system OFF immediately.
- Disconnect and lock out electrical power.
- Allow only qualified personnel to make repairs. Repair or replace the malfunctioning component according to instructions provided in its manual.

Failure to follow these instructions can result in death or equipment damage

2.0 L-880 & L-881 PAPI, Style A

L-880 & L-881 PAPI, Style A, Voltage Powered PAPI manual.



2.1 About this manual

The manual shows the information necessary to:

- Install
- Carry Out Maintenance
- Carry Out Troubleshooting on the L-880 & L-881 PAPI, Style A.

2.2 How to work with the manual

1. Become familiar with the structure and content.
2. Carry out the actions completely and in the given sequence.

3.0 PAPI A Overview

See [Figure 1](#) and [Figure 2](#). This section describes the Style A, L-880 and L-881 Precision Approach Path Indicator (PAPI) systems used to provide visual approach path guidance to pilots of landing aircraft. The PAPI system is designed to operate from 220/240

Vac 60 Hz power.

Figure 1: L-880 Four-Box System

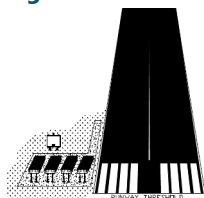
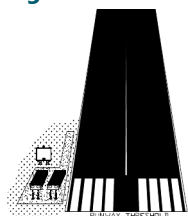

Figure 2: L-881 Two-Box System



3.1 Precision Approach Path Indicator

Uses

A PAPI system uses either 2-light channel or 3-light channel units, which offer the pilot information to carry out the approach procedure with the utmost accuracy and safety.

The L-880 PAPI system consists of four light units located at the side of the runway adjacent to the origin of the glide path. The nominal glide slope angle is midway between the angular settings of the central pair of the four units. If an aircraft is on the correct approach path, the pilot will see two red and two white light indicators.

If the aircraft approach is too high, an increased number of white light indicators will be seen. If the approach is too low, the pilot will note an increased number of red light indicators. The L-881 PAPI system is identical to the L-880, except only two light units (instead of four) are used. The nominal glide slope is midway between the angular settings of the two units, and when the pilot is on or close to the correct approach path, the unit nearest the runway will be seen as red and the other unit as white.

The Style A system is for use with either a 220 or 240 VAC input voltage. The Style B system is for use on 6.6 or 20 A series circuits. A tilt switch assembly is provided on each PAPI unit to de-energize the system in the case that the optical pattern of any light unit is raised between 0.5° and 1.0° or lowered between 0.25° and 0.5° with respect to the setting angle of the unit.

Electrical Supply

Style A ¹	
Input Voltage: 220-240 VAC ± 10% (VA max.) ²	
L-880 (4-box) 2-lamps/optical box	1,800
L-880 (4-box) 3-lamps/optical box	2,700
L-881 (2-box) 2-lamps/optical box	1,650
L-881 (2-box) 3-lamps/optical box	1,650
Style B	
Two Lamp – 6.6 A through one 500 W isolation transformer	

L-880 (4-Box) – Total CCR Load ³	1960 VA maximum
L-881 (2-Box) – Total CCR Load ³	980 VA maximum
Three Lamp – 6.6 A through one 500 W and one 200 W isolation transformer	
L-880 (4-Box) – Total CCR Load ³	3,160 VA maximum
L-881 (2-Box) – Total CCR Load ³	1,580 VA maximum

Notes

- ¹ Limit on distance from Master to first light unit is 100 ft (30.5 m)
- ² As seen at input of PAPI Master
- ³ Includes PAPI light units and isolation transformers

3.2 Type L-880 PAPI System

See Figure 1, Figure 3, and Figure 4. The L-880 PAPI system consists of four identical light units that are normally installed on the left side of the runway (viewed from the approach end) in a line perpendicular to the runway centerline.

Figure 3: PAPI Obstacle Clearance Surface

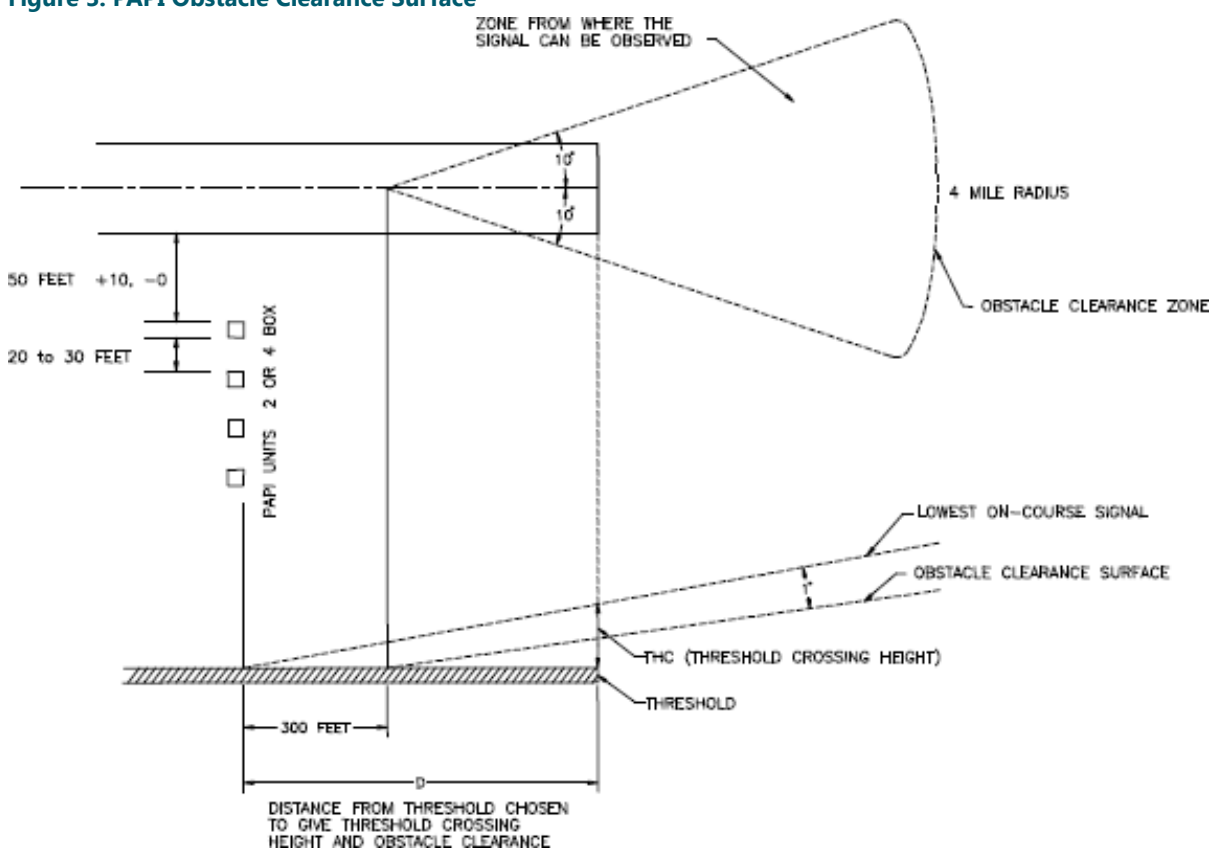
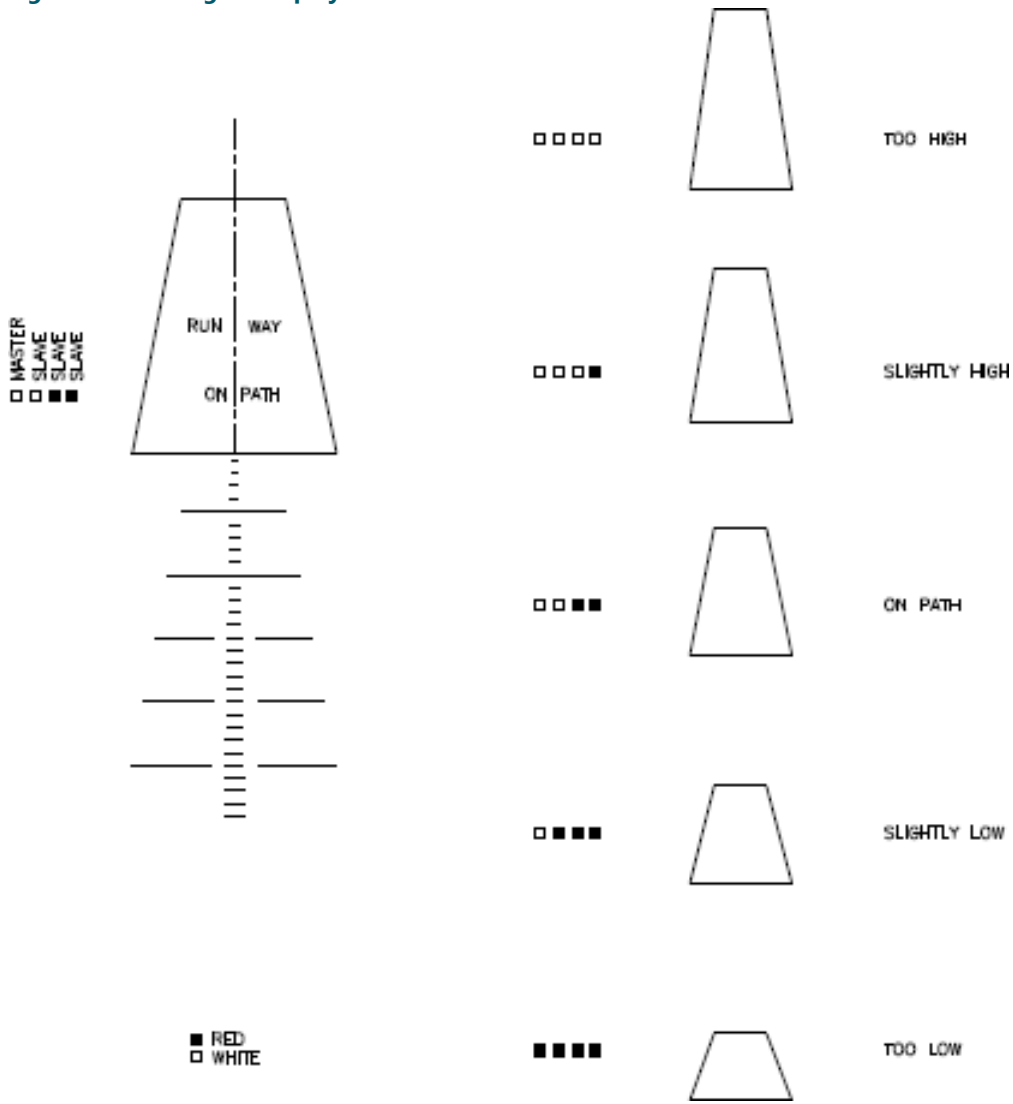

Figure 4: L-880 Signal Display



The units are aimed so that during a landing approach the pilot will see the following signal format:

- The inner two units as red and the outer two units as white when the aircraft is close to or on the approach slope.
- The unit nearest the runway as red and the three units farthest from the runway as white when above the approach slope; all four units appear white if the aircraft is excessively above the approach slope;
- The three units closest to the runway are seen as red and the unit farthest from the runway as white if the aircraft is slightly below the approach slope; and still further below, all the units will appear red.

3.3 Type L-881 PAPI System

See [Figure 2](#) , [Figure 3](#) , and [Figure 5](#) . The L-881 PAPI system consists of two identical light units that are normally installed on the left side of the runway (viewed from the approach end) in a line perpendicular to the runway centerline.

Figure 5: L-881 Signal Display

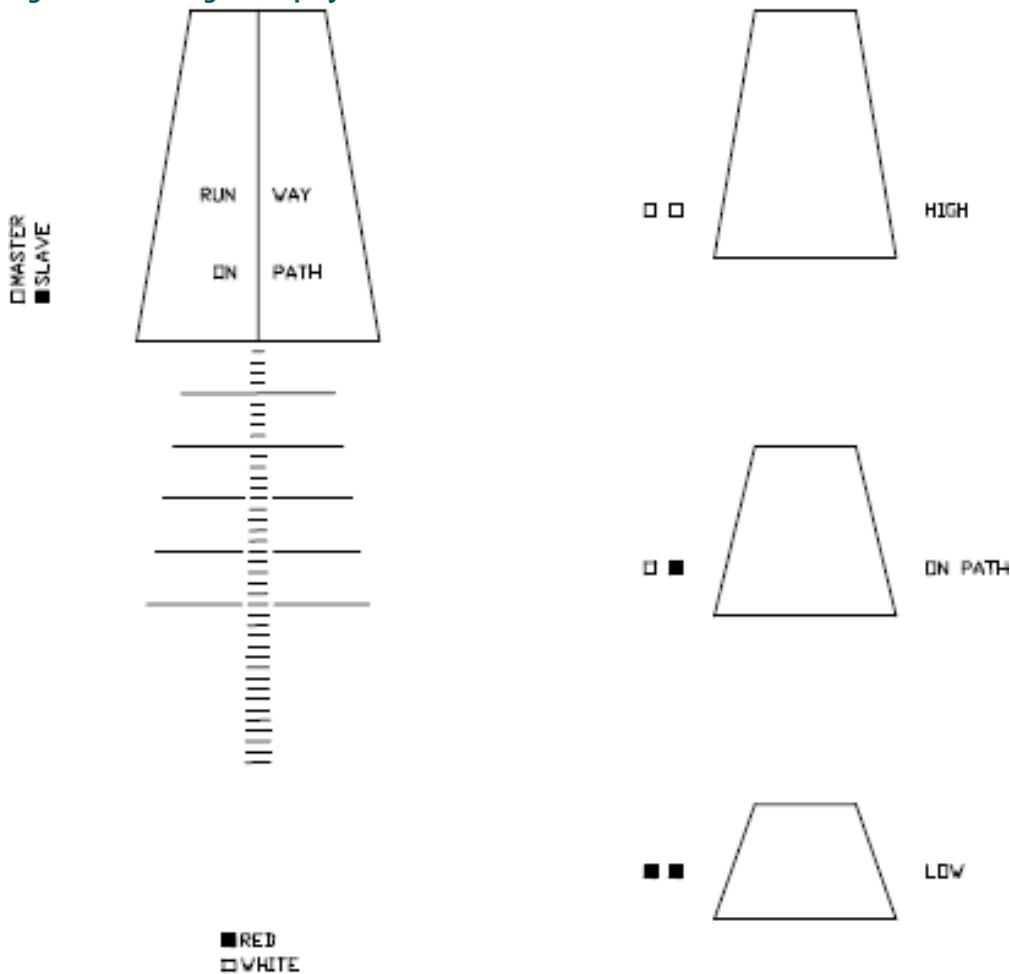

3.4 Type L-881 PAPI

The units are aimed so that during a landing approach the pilot will see the following signal format:

Both units as red when the aircraft is below the approach slope

The unit nearest the runway as red and the other unit as white when on or close to the approach slope

Both units as white when the aircraft is above the approach slope

3.5 PAPI Light Unit

See [Figure 6](#) for a 3-lamp PAPI and [Figure 7](#) for a 2-lamp PAPI. A single PAPI light unit contains two or three 6.6 A, 200 W lamps, two or three reflectors and red filters, four or six lenses, a lens shield, an electronic shorting device PCB, and a tilt switch assembly. The PAPI unit is mounted on three or four adjustable legs. Each of these parts is discussed below.

Figure 6: PAPI Light Unit (3-Lamp)

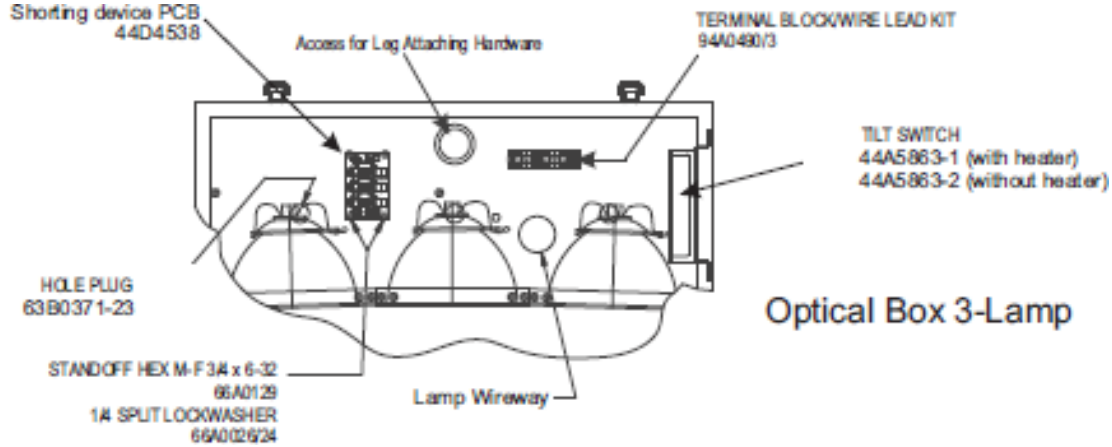
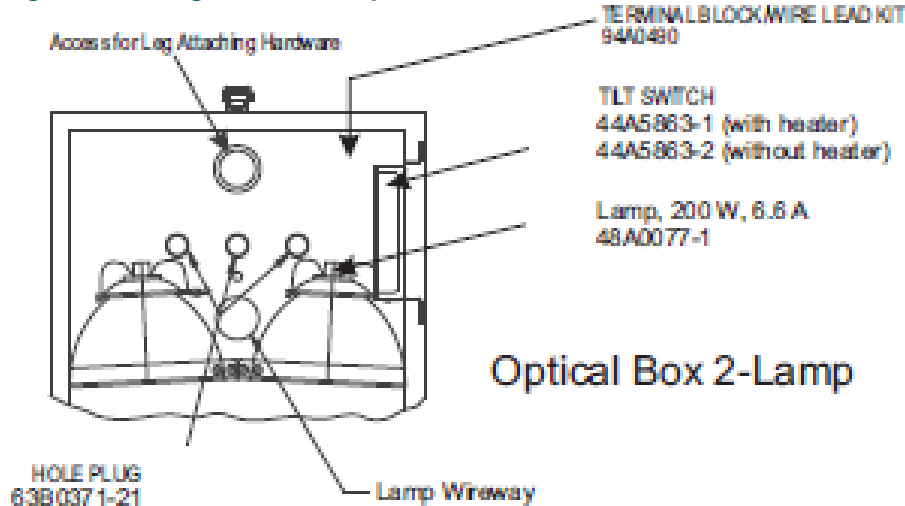

Figure 7: PAPI Light Unit (2-Lamp)



3.5.1 Lamps

Two or three 200-watt halogen lamps are located in the rear of the unit, each in an indexed lamp holder in a reflector and held in place with a forked spring clip. Slip-on type electrical connections permit easy replacement of failed lamps.

3.5.2 Reflector Panel

The reflector panel is fitted with two apertures in which the elliptical reflectors are housed. The reflectors are made of aluminum that is mechanically polished for brilliance and anodized for protection.

3.5.3 Filter Panel

The filter panel houses the two or three red filters. It also has two reference slots, C and D, used to locate the aiming device for making field adjustments of the light unit. These reference slots are precision machined in the factory. Be careful not to damage these machined slots.

3.5.4 Lens Panels

Four or six high optical quality objective lenses are housed in two or three lens panels. The upper rim of the front lens panel is equipped with two reference blocks, A and B, for field adjustment of the light unit. These blocks are precision-adjusted in the factory to be parallel with the optical centerline of the objective lenses.

3.5.5 Lens Shield

The flat glass shield (protective glass) serves to protect the lenses against materials such as sand and stone, and is designed to avoid reflections.

3.5.6 Adjustable Mounting Legs

See Figure 8 . The three or four adjustable mounting legs are each made up of two screw rods (3, 8) connected by a differential sleeve (4). The upper (smaller diameter) rod is fitted with nuts and locking nuts designed for coarse height setting of the unit. The differential sleeve is used for the fine adjustment setting of the unit. The lower (larger diameter) rod is inserted into a conduit column with frangible coupling held in place by a flange bolted on a concrete pad.

When installing the upper and lower rods in the differential make sure there is room for movement of the rods.

Figure 8: Adjustable Mounting Legs

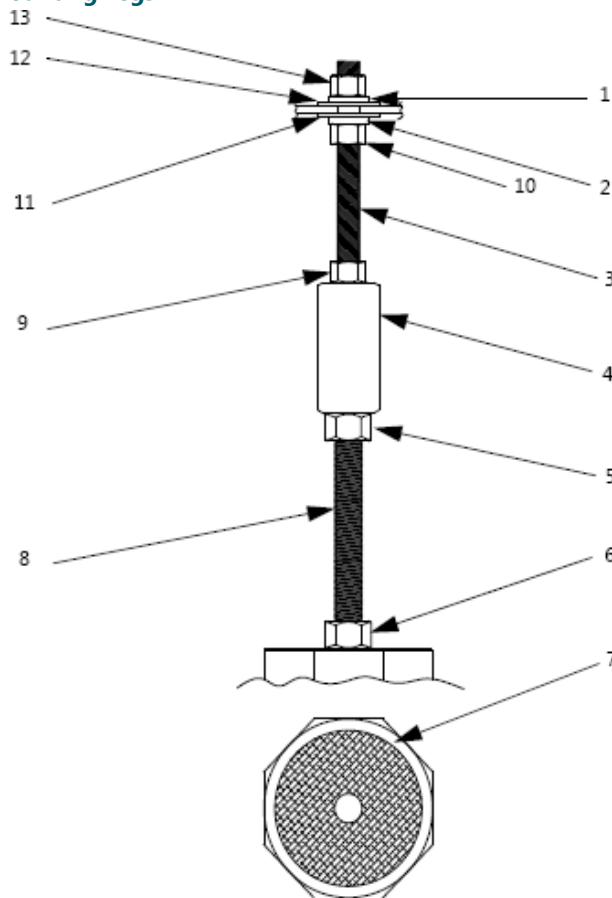

1. Upper 3/8 Split Lock Washer	5. Locking Hex Nut 1/2-13	9. 3/8-16 Hex Nut 3/8-16
2. Lower 3/8 Split Lock Washer	6. 1/2-13 Hex Nut	10. Lower Hex Nut 3/8-16
3. 3/8-16 x 6 All Thread	7. Leg Cap	11. Lower 3/8 Flat Washer
4. Differential	8. 1/2-13 x 5 All Thread	12. Upper 3/8 Flat Washer
		13. Upper Hex Nut 3/8-16

3.5.7 Tilt Switch

The tilt switch assembly is designed to de-energize the lamps if the optical pattern is raised more than 1/2 degree or lowered more than 1/4 degree with respect to the present setting angle of the light unit. A time delay of 10-30 seconds is incorporated to prevent intermittent tilt switch activation due to vibration. The tilt switch assembly has a fail-safe operation so that any malfunction of the switch including loss of power de-energizes the lamp circuits controlled by the tilt switch.

3.6 Theory of Operation

This section describes the L-880/L-881 PAPI system theory of operation. It includes operations of the master, slave, optional heater, and tilt switch.

3.6.1 Master

See [Figure 9](#) . See the *Wiring Schematics* section. 220/240 Vac is supplied to the Master box at TB1-1 and TB1-3. TB-2 is the neutral line. TB1-1 and TB1-3 is fed through VR1 and VR2 to provide lightning protection. 220/240 Vac is fed through circuit breaker CB1 and contactor K1. CB1 provides overcurrent protection. When CB1 is turned on, 220/240 Vac is fed to transformer T4. This steps the voltage down to 18 Vac. When the tilt switches are closed, this 18 Vac is fed to the LC-control PCB1, which provides power for the PCB.

When S1 is set to LOCAL or to REM and remote wires are connected, contactor K1 is energized. When contactor K1 is energized,

220/240 Vac is fed to the inductor L1, SCRs, and step-up transformer T1 (on the L-880 system only). The LC-control PCB1 turns

the SCRs on and provides 6.6 A to the lamps at TB1-13 and TB1-14. VR3 and VR4 provide lightning protection at the output.

Note
 T1-35A0494 is for 4-Box, 3-LT. Units or T1-35A0689 for 4-Box, 2-LT. Units

Figure 9: Master Component Panel

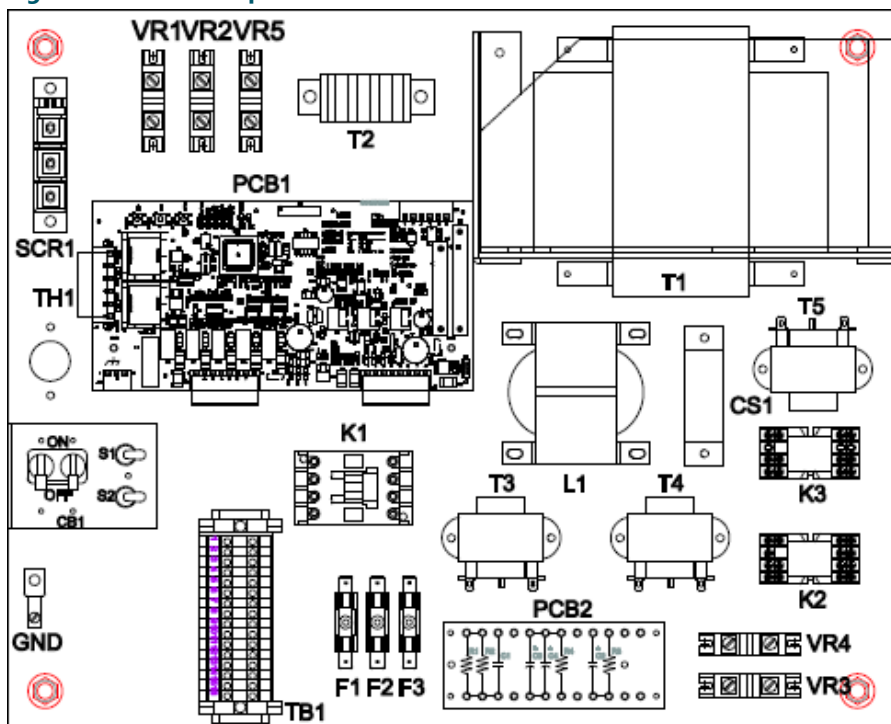

3.6.2 Daytime Operation

When the illumination on the photocell rises to 50 to 60 foot-candles, the photocell PC1 is de-energized. This de-energizes relay

K2 and provides 120 Vac to J2-7 on LC-control PCB1 and turns on the PAPI system to full intensity.

3.6.3 Nighttime Operation

When the illumination drops to 25 to 35 foot-candles, photocell PC1 energizes. This energizes relay K2 and removes 120 Vac from J2-7 on LC-control PCB1. This causes the PAPI system to operate at low intensity (if the interlock relay is used, the PAPI system will not energize until the interlock relay CS1 detects the current flow). A time delay of 45-75 seconds is incorporated in the photocell circuit to prevent switching because of stray light or temporary shadows. In case of failure of the photocell control circuitry, the system reverts to high intensity. Two night intensity settings, approximately 5% and 20% of full intensity, can be set by using toggle switch S2. This allows the user to select either of the two settings to accommodate local site conditions.



Note

Refer to [Optional Interlock Relay](#) on page 14.

3.6.4 Remote/Local Operation

Toggle switch S1 allows the unit to operate either in REM or LOCAL. When the switch is set to LOCAL, the unit can be operated locally. When the switch is set to REM and the remote wires are connected to TB1-7 and TB1-8, the unit can be operated from a remote location by a switch closure across TB1-7 and TB1-8.

3.6.5 Light Unit

See [Figure 6](#) and [Figure 7](#). Power is provided to the lamps in the light boxes via TB1-13 and TB1-14 in the master and are connected in series. The normally closed tilt switch in each unit is connected to TB1-5 and TB1-6 and are connected in series. These wires connect to TB1-9 and TB1-10 in the master unit. If the optional heater is used in the tilt switch, two wires must be connected from TB1-11 and TB1-12 on the master unit to TB1-7 and TB1-8 on all the light units to provide power to the heater when required.

3.6.6 Optional Heater

See [Figure 9](#). Thermostat TH1 in the master is used to supply 240 Vac to the heater. When the outside air temperature drops below 0 °F, the thermostat turns on. This provides 240 Vac to the heater resistors R1 in the tilt switch boxes. This prevents the mercury in the tilt switches from freezing.

3.6.7 Optional Interlock Relay

This option provides ON/OFF control through current sensing of the runway series circuit during nighttime operations.

3.6.8 Tilt Switch

The tilt switch assembly is designed to de-energize the lamps if the optical pattern is raised more than 1/2 degree or lowered more than 1/4 degree with respect to the present setting angle of the light unit. If a tilt switch is moved from proper alignment, the time delay relay in the master will de-energize after a nominal 15-second time delay, which de-energizes the system and removes the 6.6 A power supply to all the lamps in the PAPI system.

3.7 Style A L-880/L-881 PAPI: Required Equipment

Refer to [Table 1](#) and [Table 2](#) for required equipment that is supplied. Refer to [Table 3](#) for required equipment that is not supplied. Refer to the *Parts* section for ordering information.

Table 1: L-880 PAPI Required Equipment Supplied

Description	Quantity
Master PAPI assembly	1
Light box assembly	4
Field splice kit	4
Instruction manual	1 per order

Table 2: L-881 PAPI Required Equipment Supplied

Description	Quantity
Master PAPI assembly	1
Light Box assembly	2
Field splice kit	2
Instruction manual	1 per order

Table 3: Required Equipment Not Supplied

Description	Quantity	Note
Aiming device kit (optional)	1	One required per airport.
Positioning plate	1	See Table 21 through Table 27 in the <i>Installation</i> section.
Survey instrument	1	
L-867 light base for L-880 and L-881 (optional)	As required	One L-867 light base is required per light box.
L-867 base plate, 1 hub (optional)	As required	One L-867 base plate (1 hub) is required for the L-867 base near each optical box.
1-1/4 inch (31.75 mm) flex conduit male connector	As required	Supplied by contractor. Refer to Table 4 for quantities.
1-1/2 inch x 1-1/4 inch (38.1 x 31.75 mm) hex reducer bushing	As required	Supplied by contractor. Refer to Table 4 for quantities.
1-1/4 inch (31.75 mm) flex conduit/fluid tight	As required	Supplied by contractor. Refer to Table 4 for quantities.
Interconnector cable (6- conductor)	As required	Supplied by contractor. Refer to Table 4 for quantities.
Concrete	As required	
L-830 30 W/45 W transformer	1	Required only with interlocking relay option.
Primary connector kit	1	Required only with interlocking relay option.

Table 4: Contractor-Supplied Connectors, Conduit, Cable, and Bushings

Description	L-880 PAPI				L-881 PAPI		L-880/881 PAPI
	Light Box #1	Light Box #2	Light Box #3	Light Box #4	Light Box #1	Light Box #2	Master Box
1 1/4 flex conduit male connector	2	2	2	2	2	2	
1 1/2 x 1 1/4 hex reducer bushing	1	1	1	1	1	1	
1 1/4 flex conduit/fluid tight	1	1	1	1	1	1	
Inter-connector cable (6-conductor)	2	1	1	1	2	1	2

3.8 Specifications

This subsection describes the specifications for the L-880 (4 box) and L-881 (2 box) PAPI systems. Refer to the *Parts* section for part numbers.

3.8.1 Lamps

Two or three 200 W, 6.6 A quartz lamps per PAPI unit

3.8.2 Lamp Life

1000 hours

3.8.3 Transmission Factor of Red Sector

At least 15%

3.8.4 Transmission Sector

Three minutes of arc over full beam spread

3.8.5 Visual Acquisition Range

7.1 miles within an approach envelope of ± 5 degrees from the approach axis

3.8.6 Transient Suppression

Solid state equipment is capable of withstanding lightning transient consisting of a 10 x 20 microsecond current surge of 15,000 amperes with the subsequent power-follow current and voltage surge of 10 kV/microsecond. System also will withstand without damage the repeated application of an overvoltage transient on the input power lines equal to 500 volts peak for a duration of 50 milliseconds.

3.8.7 Tilt Switch

De-energizes all lamps in the PAPI system if optical pattern of any light unit is raised more than 1/2 degree or lowered more than 1/4 degree.

3.8.8 Mean Time Between Failures

Six months (minimum) between failures for all components (excluding lamps)

3.8.9 Environmental Operating Conditions

The environmental operating conditions includes temperature range of operation, humidity, and wind.

3.8.9.1 Humidity

0 to 100%

3.8.9.2 Wind

Velocities up to 100 mph (161 km/h)

3.8.10 Mounting Provisions

Three or four mounting legs

3.8.11 Photometrics

Each light unit used in the L-880/L-881 PAPI systems has two/three lamps and provides a beam of light split horizontally to produce white light in the top sector and red light in the bottom sector. When viewed by an observer at a distance of 1000 feet (304.8 m), the transition from red light to white light occurs within an angle of three minutes of arc at the beam center and within an angle of five minutes of arc at the beam edges.

3.9 Digital Protractor Specifications

This subsection provides specifications for the optional digital protractor used to aim the PAPI.

3.9.1 Range

Range is 360 degrees (90 degrees x 4).

3.9.2 Resolution

Resolution is 0.01 degree (0 to 9.99 degrees).

Resolution is 0.10 degree (10 to 90 degrees).

3.9.3 Accuracy

Refer below for digital protractor accuracy.

±0.05 degree (0 to 10 degrees).

±0.10 degree (80 to 90 degrees).

±0.20 degree (10 to 80 degrees).

3.9.4 Repeatability

Repeatability is ±0.05 degree.

3.9.5 Supply Voltage

9 volt alkaline battery.

3.9.6 Battery Life

500 hours typical.

3.9.7 Temperature

Operating temperature: -5 to 50 °C (23 to 122 °F).

Storage temperature: -20 to 65 °C (-4 to 149 °F).

3.9.8 Weight

Weight is 295 g (10.4 oz).

4.0 Installation



WARNING

Read installation instructions in their entirety before starting installation.

- Become familiar with the general safety instructions in this section of the manual before installing, operating, maintaining or repairing this equipment.
- Read and carefully follow the instructions throughout this manual for performing specific tasks and working with specific equipment.
- Follow all applicable safety procedures required by your company, industry standards and government or other regulatory agencies.
- Protect equipment with safety devices as specified by applicable safety regulations.

Failure to follow these warnings may result in serious injury or equipment damage.

This section provides instructions for the installation of the PAPI system. Refer to the airport project plans and specifications for the specific installation instructions.

4.1 Unpacking

Handle equipment very carefully to prevent component damage. Note any exterior damage to the crate that might lead to detection of equipment damage. If you note any damage to any equipment, file a claim with the carrier immediately. The carrier may need to inspect the equipment.

4.2 Instruments for Installation and Verification

This subsection provides information about the instruments necessary to install the PAPI.

4.2.1 Installation Using Bubble-Level Style Aiming Device

The instruments below are required for installing, leveling, setting, and checking the elevation setting of the light units using the bubble-level style aiming device.

- One bubble-level style aiming device for azimuth and elevation setting.
- One precision bubble level for leveling the units.
- One checking stick for routine checks of the elevation setting.

4.2.2 Bubble-Level Style Aiming Device

The bubble-level style aiming device consists of the following:

- One base to rest on reference block B and slot C, and two movable arms to rest on reference block A and slot D.
- Two graduated scales for elevation setting.
- One bar used for the longitudinal horizontal reference required to set both azimuth and elevation.

Bubble Level

This instrument has a 0.004 in/ft (0.3 mm/m) degree of precision which allows a very precise setting (within one minute of arc) compatible with the design precision of the PAPI light unit.

Checking Stick

See [Figure 10](#). The checking stick is used to make routine checks of the elevation setting of the PAPI units. It consists of a small transparent screen attached to a lightweight rod.

The screen has two horizontal lines 23 mm (0.90 in.) apart to correspond to approximately 3 minutes of arc at 25 m (82 ft). Refer to *Reference Bases for Checking Stick* in this section for instructions on using the checking stick.

Figure 10: Checking Stick

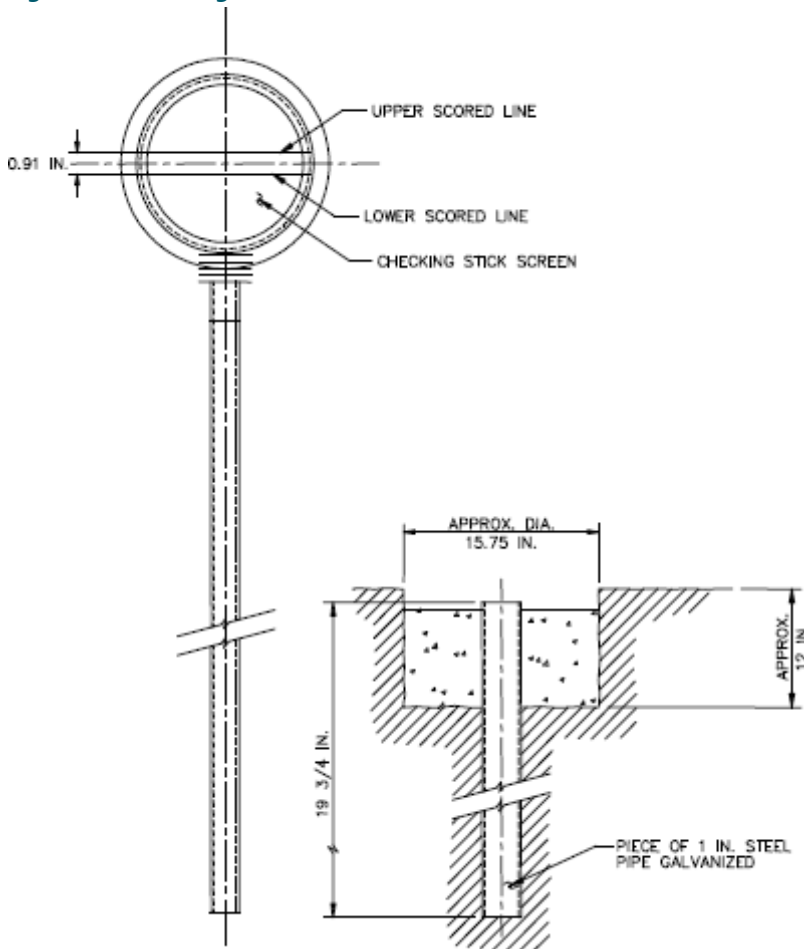

4.2.3 Installation Using Digital-Level Style Aiming Device

The instruments below are required for installing, leveling, setting, and checking the elevation setting of the light units using the digital-level style aiming device.

- one digital-level style aiming device for azimuth and elevation setting
- one precision digital protractor for leveling the units and setting the tilt switch

Digital-Level Style Aiming Device

See [Figure 11](#) and [Figure 12](#) for the digital-level aiming device. The digital-level style aiming device consists of the following:

- One base to rest on reference block B and slot C, and long arms to rest on reference block A.
- One bar used for the longitudinal horizontal reference required to set both azimuth and elevation.



Note

[Figure 11](#) and [Figure 12](#) show the aiming device on the two-lamp PAPI. These figures also apply to the three-lamp PAPI.

Figure 11: Side View of Digital-Level Aiming Device for Two-Lamp PAPI



The two movable arms increase the stability of the aiming device and are used to establish the transverse horizontal references. Screws are provided on the bar and on the movable arms to guarantee an exact positioning of the level during setting and adjustment. This exact positioning is required to have a perfect match between the level and the longitudinal and transverse horizontal references. The two V-sights on the bar of the aiming device are for azimuth alignment.

Figure 12: Top View of Digital-Level Aiming Device for Two-Lamp PAPI

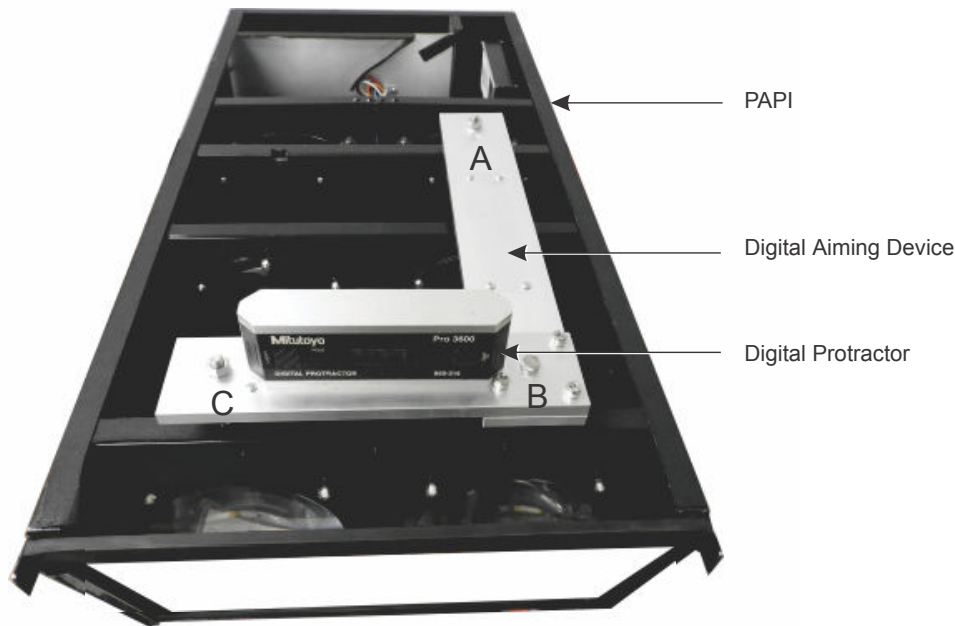

Digital Protractor

For information on the digital protractor, refer to *How Digital-Level Aiming Device Works* in this section and *Operating Digital Protractor* in the Operation section.

4.3 Siting Considerations

When viewed from the approach end, the PAPI system shall be located on the left-hand side of the runway as shown in [Figure 3](#). The PAPI may be located on the right side of the runway if siting problems exist, such as conflicts with runways or taxiways. The PAPI must be sited and aimed so that it defines an approach path with adequate clearance over obstacles and a minimum threshold crossing height.

If the runway has an established ILS glideslope, refer to *Siting PAPI with ILS Glideslope* in this section. The PAPI must be installed so that the visual glideslope coincides (as much as possible) with the electronic glideslope. If there is no ILS on the runway, refer to *Siting PAPI on Runways Without an ILS* in this section. The PAPI's glideslope must be chosen to ensure the on-course signal of the PAPI provides adequate clearance over obstacles.

4.3.1 Distance of PAPI Units from Runway Edge

See [Figure 3](#). The light unit nearest to the runway shall be no closer than 50 feet (15.24 m) (+10, -0 feet) (+3.048, -0 m) from the runway edge or to other runways or taxiways.

This distance may be reduced to 30 feet (9.144 m) for small general aviation runways used by non-jet aircraft.

4.3.2 Lateral Spacing of PAPI Units

The PAPI units shall have a spacing between units of 20 to 30 feet (6.096 to 9.144 m). The distance between boxes shall not vary by more than 1 foot (304.8 mm).

4.4 Siting PAPI with ILS Glideslope

When a runway has an established ILS electronic glideslope, the PAPI on-slope signal should coincide, as much as possible, with that for the ILS. To accomplish this, place the PAPI at the same distance (tolerance of ± 30 feet or ± 9.144 m) from the threshold as the virtual source of the ILS glideslope and aim at the same angle as the ILS glideslope.

Refer to [Table 5](#) . This procedure must be modified for runways that serve aircraft in height group 4 because of the eye-to-antenna distance. For these runways, the distance of the PAPI from the threshold shall equal the distance to the virtual source of the ILS glideslope plus an additional

300 feet (91.44 m) (+50 ft, -0 ft) (+15.24 m, -0 m). Calculations should be performed to ensure that the site chosen provides adequate obstacle clearance and threshold crossing height.

Table 5: Threshold Crossing Height

Type of Aircraft	Cockpit-to-Wheel Height	Visual Threshold Crossing Height	Remarks
Height Group 1 (General aviation, small commuters, corporate turbojets)	10 feet (3.048 m) or less	40 feet (12.2 m) (+5 ft, -20 ft) (+1.524 m, -6.1 m)	Many runways less than 6,000 ft (1828.8 m) long with reduced widths and/or restricted weight bearing which would normally prohibit landings by larger aircraft
Height Group 2 (F-28, CV-340/440/580, B-737, DC-8/9)	15 feet (4.6 m)	45 feet (13.7 m) (+5 ft, -20 ft) (+1.524 m, -6.1 m)	Regional airport with limited air carrier service
Height Group 3 (B-707/720/727/757)	20 feet (6.1 m)	50 feet (15.24 m) (+5 ft, -15 ft) (+1.524 m, -4.6 m)	Primary runways not normally used by aircraft with ILS glideslope-to-wheel heights exceeding 20 ft (6.1 m)
Height Group 4 (B-747/767, L-1011, DC-10, A-300)	Over 25 feet (7.6 m)	75 feet (22.9 m) (+5 ft, -15 ft) (+1.524 m, -4.6 m)	Most primary runways at major airports.

4.5 Siting PAPI on Runways Without ILS

When the runway doesn't have an ILS glideslope, the PAPI must be sited and aimed so that it defines an approach path which will produce the required threshold crossing height and clearance over any obstacles in the approach area.

4.5.1 Threshold Crossing Height (TCH)

See [Figure 3](#) . The TCH is the height of the lowest on-course signal at a point directly above the threshold and the runway centerline. The minimum allowable TCH depends on the height group of the aircraft using the runway, and is shown in [Table 5](#) . The glideslope of the PAPI must provide the proper TCH for the most demanding aircraft height group using the runway.

4.5.2 Glideslope Angle

The standard visual glideslope angle for the PAPI is 3 degrees. For non-jet runways, this may be raised to 4 degrees if required to provide obstacle clearance.

4.5.3 Distance of PAPI from Threshold

The following method can be used to determine the PAPI installation distance from the runway threshold provided there are no obstacles in the area from which the PAPI signals can be observed, no differences in elevation between the threshold and the installation zone of the PAPI or between the units, or reduced length of runway. The distance of the PAPI units from the threshold (D1) can be calculated from the equation:

$D1 = TCH \times \cot(\text{angle of lowest on-course signal})$ where the TCH is the threshold crossing height for the most demanding aircraft using the runway. Refer to [Table 5](#) . The angle of the lowest on-course signal is determined as follows:

For the L-880 PAPI system the angle of the lowest on-course signal will be the aiming angle of the third light unit from the runway minus 1.5 minutes or arc.

Note

The subtraction of 1.5 minutes of arc takes into account the width of the transition sector (3 minutes of arc) between the white and red part of the PAPI light beam. The lowest possible on-course signal is $3/2 = 1.5'$ lower than the aiming angle.

For the L-881 PAPI system this angle will be the aiming angle of the outside light unit minus 1.5 minutes of arc.

4.5.4 Obstacle Clearance Surface

Position and aim the PAPI so that no risk exists of an obstruction being located in an area where the PAPI signals can be observed. Make a survey of the site to determine if an obstruction is present in the area where you can observe the PAPI signals.

See Figure 3 . This obstacle clearance surface begins 300 feet (91.44 m) in front of the PAPI units (closer to the threshold) and proceeds outward into the approach area at an angle of 1 degree less than the lowest on-course signal. This surface extends 10 degrees on either side of the runway centerline to a distance of 4 miles (6.44 km) from the point of origin.

If an obstruction penetrates the obstacle clearance surface and cannot be removed, then

re-aim the glideslope angle or move the PAPI system further from the threshold. By moving or re-aiming the PAPI, re-position the

obstacle clearance surface so that it will not be penetrated by an obstruction. See Figure 13 .

Figure 13: Obstacle Clearance Surface

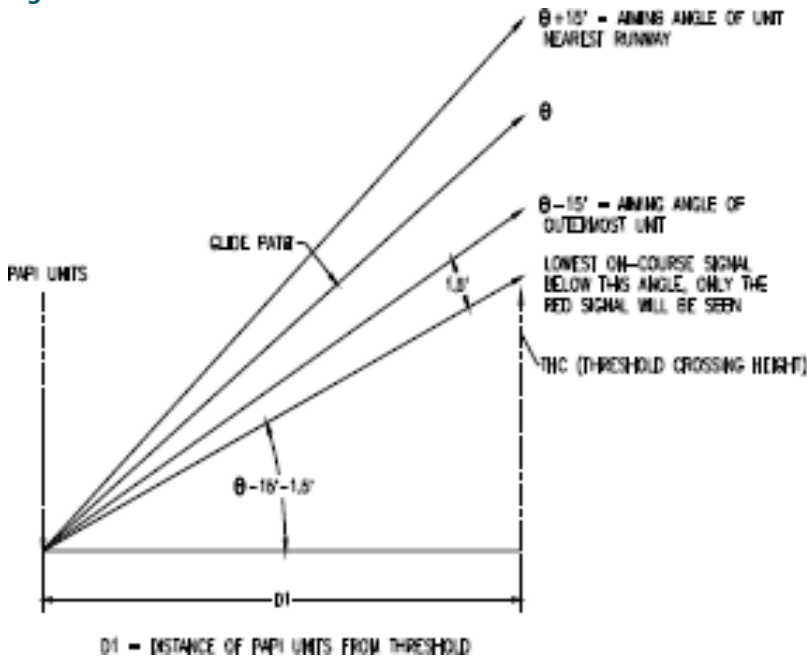

The 1.5' is one-half the width of the transition sector of the light beam. The transition between the white to red part of the beam is 3 minutes of arc (3'). Hence the additional 1.5' must be taken into account in calculating D1.

For L-881: $D1 = TCH \times \cotan (\Theta - 15' - 1.5')$

Note

For the L-880 PAPI system, the lowest on-course signal will be the aiming angle of the third light unit from the runway minus 1.5'. For a standard L-880 installation the lowest on-course signal will be $\Theta - 10' - 1.5'$. For Height Group 4 aircraft this angle will be $\Theta - 15' - 1.5'$.

For L-880 (Standard Installation): $D1 = TCH \times \cotan (\Theta - 10' - 1.5')$

For L-880 (Ht. Group 4 aircraft): $D1 = TCH \times \cotan (\Theta - 15' - 1.5')$

4.5.5 Reduction of Beam Coverage for Obstacle Avoidance

A PAPI system may require a reduction of the horizontal beam coverage because of an obstacle in the approach area. If this is the case, special consideration should be given to the following factors when determining the required system cutoff angle(s):

Type and location of the obstacle with respect to the area where the PAPI signals can be observed

- Wingspan of aircraft using the runway
- Vertical pitch of the glideslope
- Installation tolerances
- Position of the PAPI system
- Additional safety considerations
- Manufacturing tolerances are $+0.0^\circ$ to -0.4°
- Origin of the cutoff angle should be either the outermost or innermost unit (whichever is closest in azimuth to the obstacle)
- When ordering a PAPI system with a reduced horizontal beam coverage from ADB SAFEGATE, the following information is required:
 - Number of systems required
 - Type of system -- L-880 or L-881; Style A or Style B
 - Required cutoff angle (from pilot's viewpoint and tolerance)



Note

For example, if the nominal required cutoff is 7° , the cutoff angle which would be ordered is 7.2° ($+0.0^\circ$, -0.4°). The additional 0.2° is added to the nominal value because it is the midpoint of the manufacturing tolerance ($+0.0^\circ$, -0.4°). The sales order would say, for example, cutoff = 7° Right (from pilot's viewpoint).

Left/right cutoff (from pilot's viewpoint when landing)

4.6 Siting Tolerances

Siting tolerances involve azimuthal aiming, mounting height tolerance, PAPI tolerance along a line perpendicular to the runway, and correction for the runway longitudinal gradient.

4.6.1 Azimuthal Aiming

Each light unit shall be aimed outward into the approach zone on a line parallel to the runway centerline within a tolerance of $\pm 1/2^\circ$.

4.6.2 Mounting Height Tolerance

The beam centers of all light units shall be within ± 1 inch (25.4 mm) of a horizontal plane. This plane shall be within ± 1 foot (304.8 mm) of the elevation of the runway centerline at the intercept point of the visual approach angle with the runway except for additional siting considerations. Refer to *Additional Siting Considerations* in this section.

4.6.3 PAPI Tolerance Along Line Perpendicular to Runway

The front face of each light unit in a bar shall be located on a line perpendicular to the runway centerline within ± 6 inches (152.4 mm).

4.6.4 Correction for Runway Longitudinal Gradient

See Figure 14. Refer to AC 150/5435-28. On runways where a difference exists in elevation between the runway threshold and the elevation of the runway centerline adjacent to the PAPI, you may need to adjust the location of the light units with respect to the threshold to meet the required obstacle clearance and TCH.

Figure 14: Correction for Runway Longitudinal Gradient

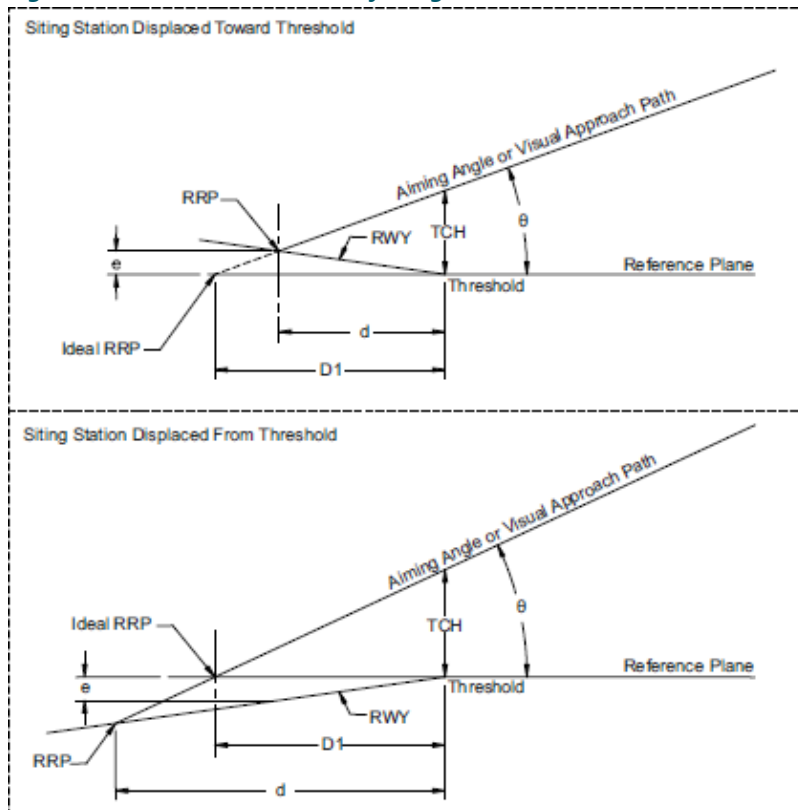

If the condition exists, perform the following steps to compute the change in the distance from the threshold required to preserve the proper geometry:

1. Obtain the runway longitudinal gradient. This can be done by survey or obtained from airport obstruction charts or as-built drawings.
2. Determine the ideal (zero gradient) distance from the threshold in accordance with the preceding instructions.
3. Assume a level reference plane at the runway threshold elevation. Plot the location determined in Step 2 above.
4. Plot the runway longitudinal gradient.
5. Project the visual glideslope angle to its intersection with the runway longitudinal gradient. Then solve for the adjusted distance from the threshold either mathematically or graphically. Refer to *Mounting Height Tolerance* in this section.
6. Verify the calculated location gives the desired threshold crossing height.

4.7 Additional Siting Considerations

Below are additional siting considerations.

- Where the terrain drops off rapidly near the approach threshold and severe turbulence is experienced, locate the PAPI farther from the threshold to keep the aircraft at the maximum possible threshold crossing height.
- On short runways, the PAPI should be as near the threshold as possible to provide the maximum amount of runway for braking after landing.
- See [Figure 15](#). At locations where snow is likely to obscure the light beams, install the light units up to a maximum height of 6 feet (1.83 m) above ground level. This may require installing the light units farther from the runway edge to ensure adequate clearance for the most critical aircraft.

Since increasing the height of the light units also increases the threshold crossing height of the visual glideslope, you may need to relocate the lights closer to the threshold to remain within the specified tolerance.

- Since the effectiveness of the PAPI system is dependent on the optical red and/or white signal pattern from the light units, make sure that no other lights are close enough to confuse the pilot.

Figure 15: Relocating PAPI Units

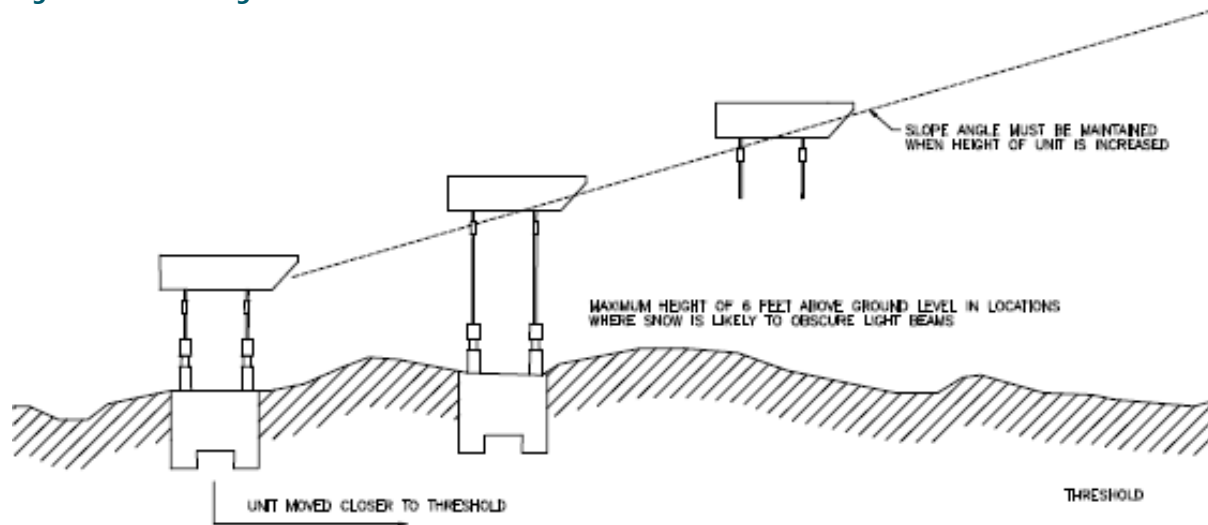

4.8 PAPI Foundations

The PAPI units shall be installed on concrete pads at ground level with frangible couplings. The foundation should extend at least

12 inches (304.8 mm) below the frost line and at least 1 foot (304.8 mm) beyond the light unit to minimize damage from mowers.

Figure 16 through Figure 19 show dimensions that are generally acceptable for the concrete pad for the two-lamp and three-lamp

PAPI respectively.

Figure 16: Installation on Concrete Pad (Two-Lamp, Three-Leg PAPI)

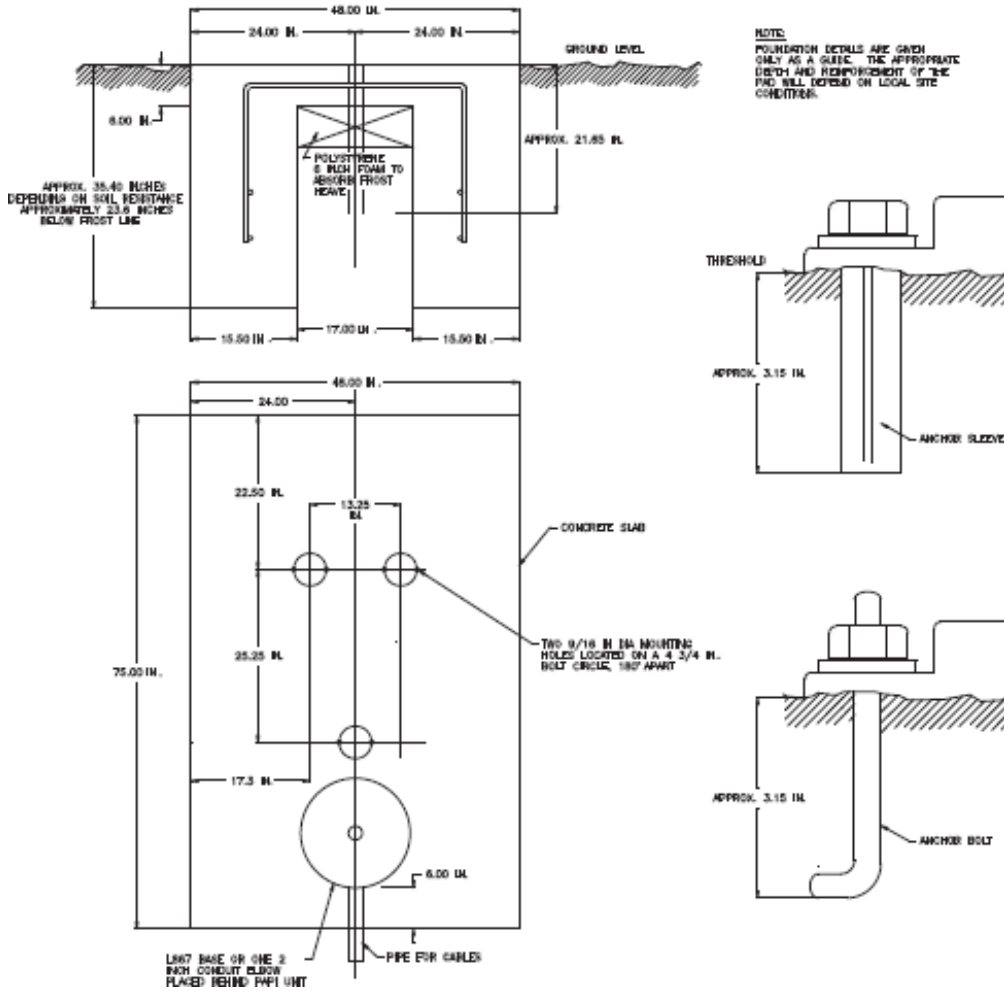

Figure 17: Installation on Concrete Pad (Two-Lamp, Four-Leg PAPI)

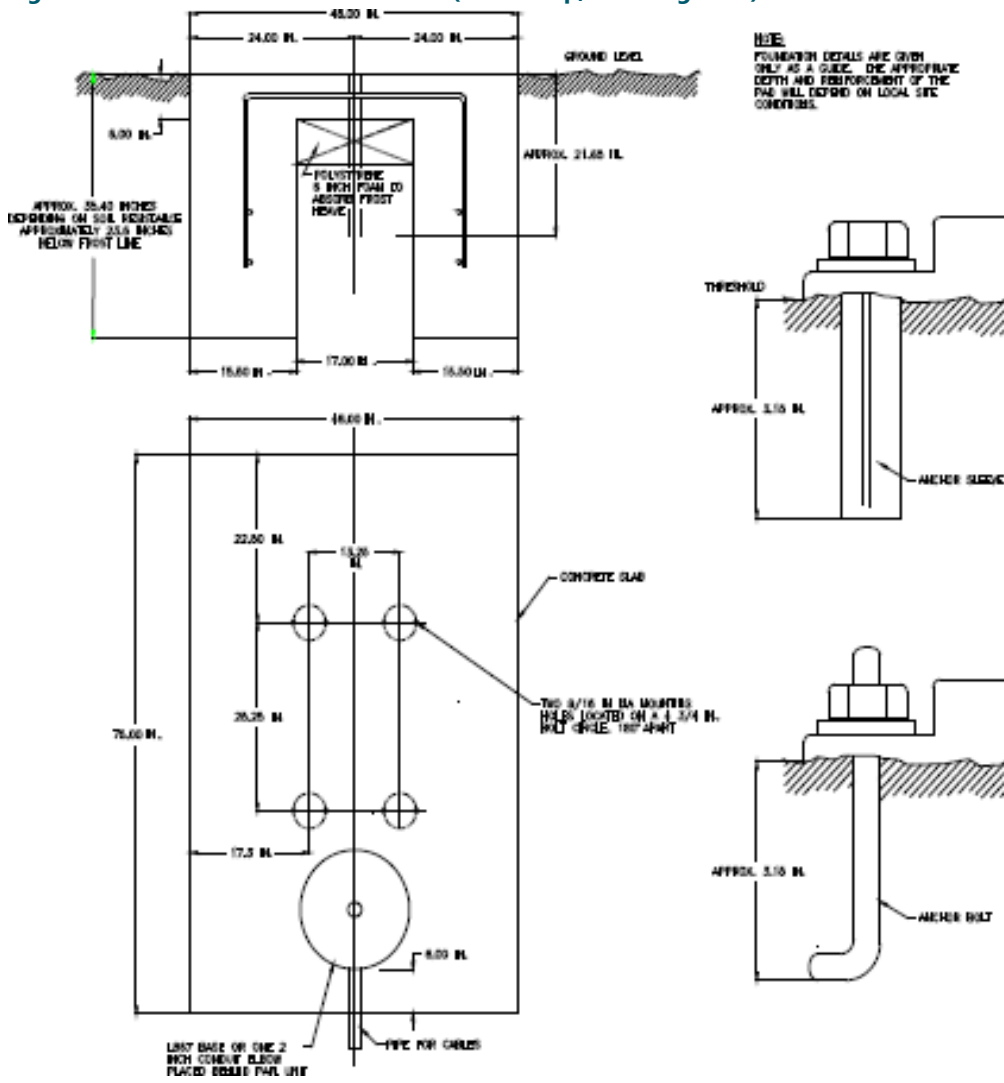

Figure 18: Installation on Concrete Pad (Three-Lamp, Three-Leg PAPI)

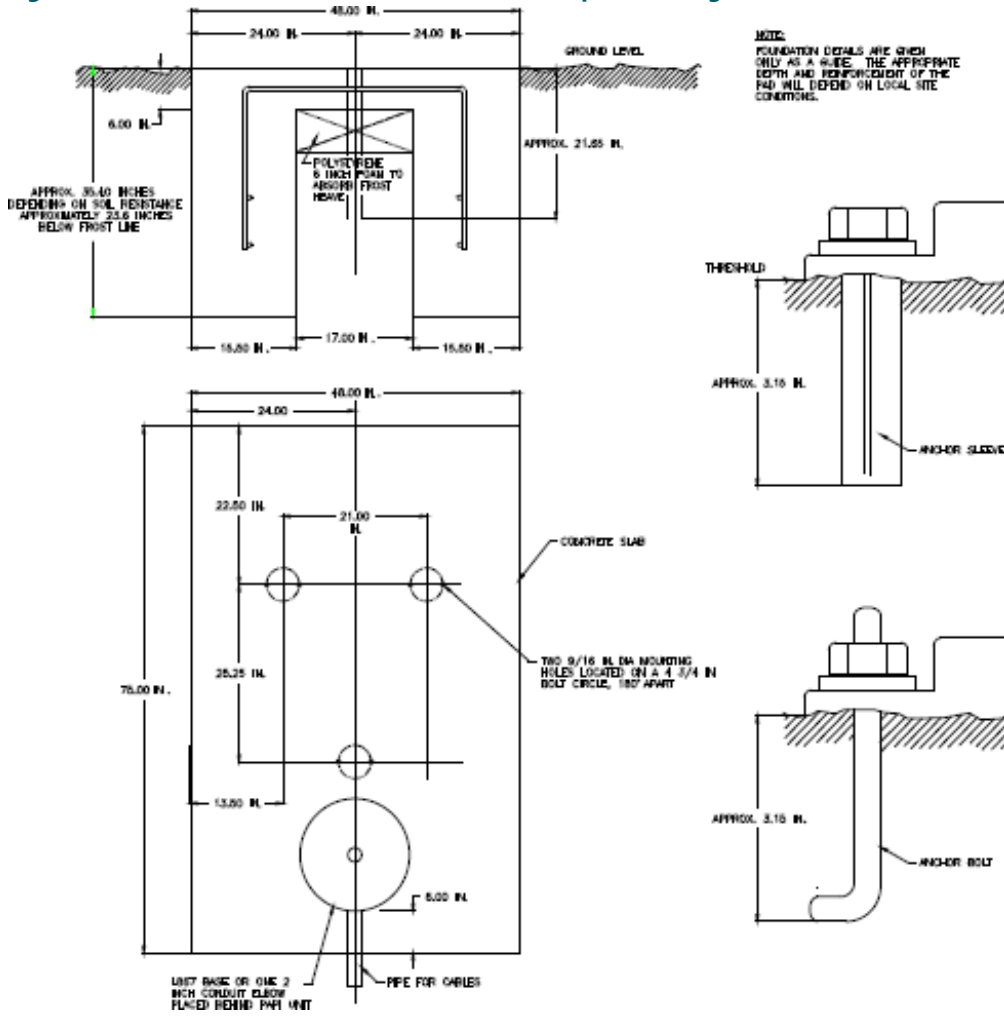
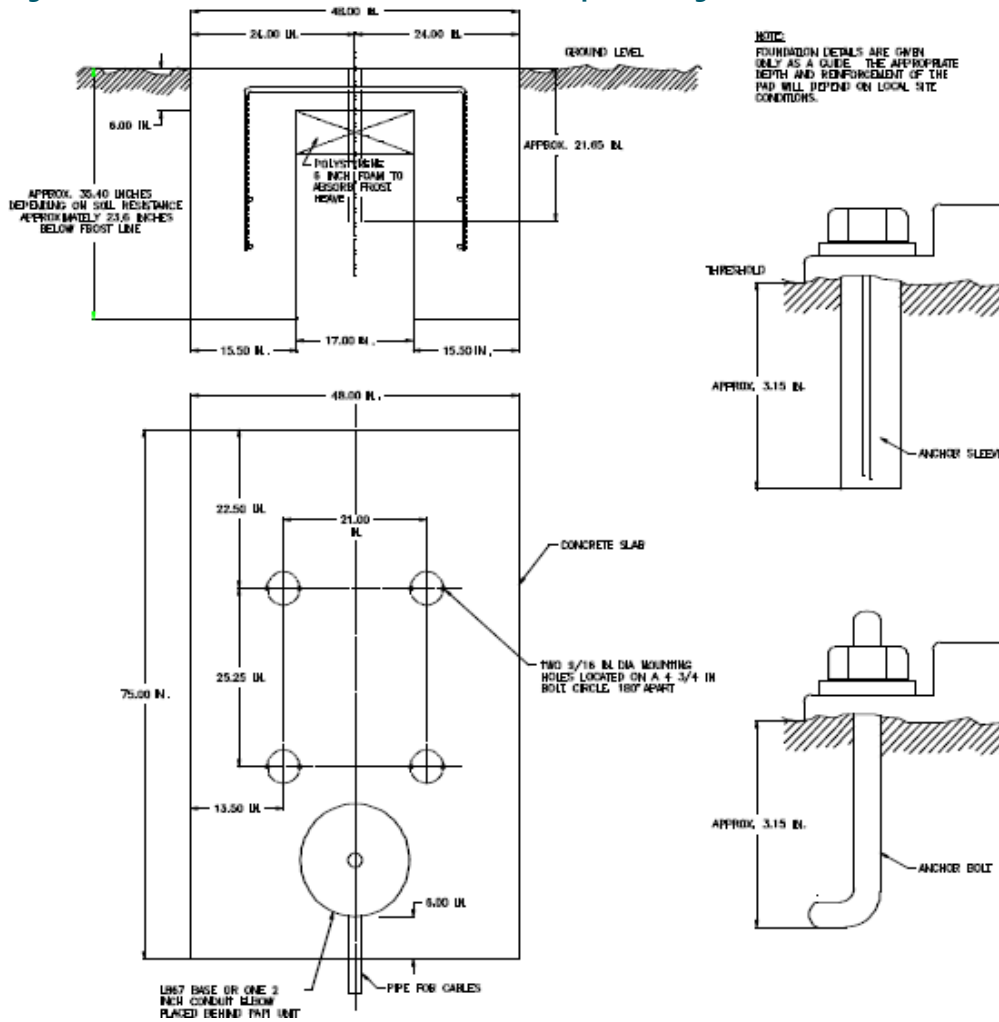

Figure 19: Installation on Concrete Pad (Three-Lamp, Four-Leg PAPI)



To cast the concrete pad and anchor the support fixtures, perform the following procedure:

1. Stake out the longitudinal axis of the light units parallel to the runway centerline.
2. Dig the foundation hole per [Figure 16](#) and [Figure 17](#) for the two-lamp and [Figure 18](#) and [Figure 19](#) for the three-lamp.
3. Place foam in pit to absorb frost heave below the central part of the slab. Place L-867 light base/conduit elbows or pipes for cables. Place bars for reinforcement of concrete.
4. Pour in concrete and allow it to harden for at least one day.
5. After concrete sets up, using chalk draw a longitudinal axis (in accordance with the axis staked out on the ground) on the upper surface of the pad. Draw a transverse axis perpendicular to the other axis.
6. See [Figure 20](#) and [Figure 21](#) for the two-lamp/three- and four-leg and [Figures 3-15](#) and [3-16](#) for the three-lamp/three- and four-leg PAPI. Lay a positioning plate on the pad; center it by positioning the central hole at the intersection of both axes; align the plate along the longitudinal axis using the V-notches in the plate.
7. Mark the eight locations of the screws on the slab; drill the eight holes to the diameter and depth required for the expansion sleeves and insert the sleeves.
8. See [Figure 20](#) through [Figure 23](#) to locate flanges using mounting templates. Place and fasten the flanges with two screws.

Figure 20: Positioning Plate (Two Lamps/Three Legs)

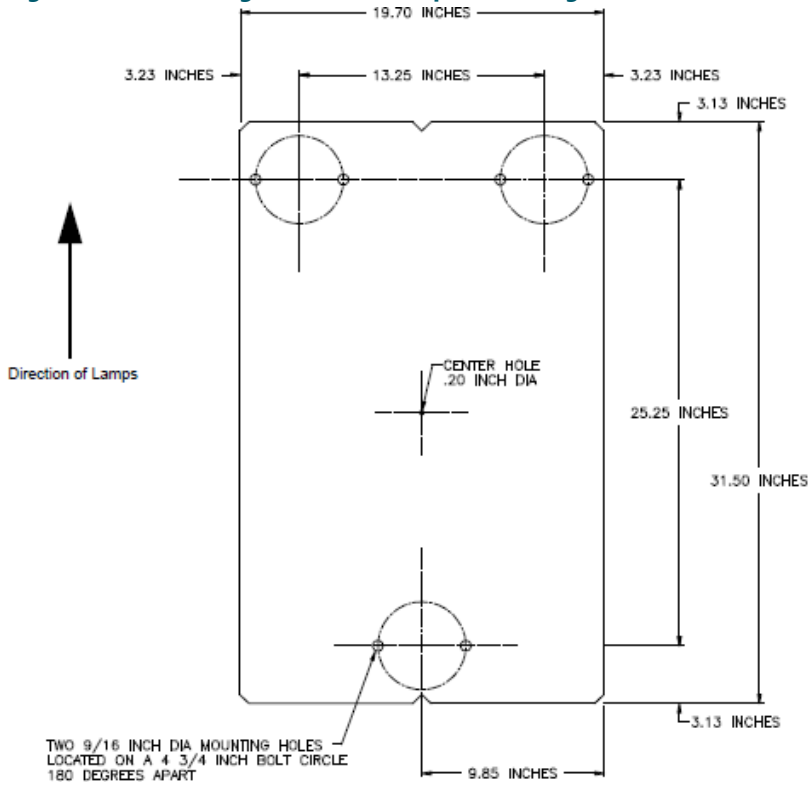

Figure 21: Positioning Plate (Two Lamps/Four Legs)

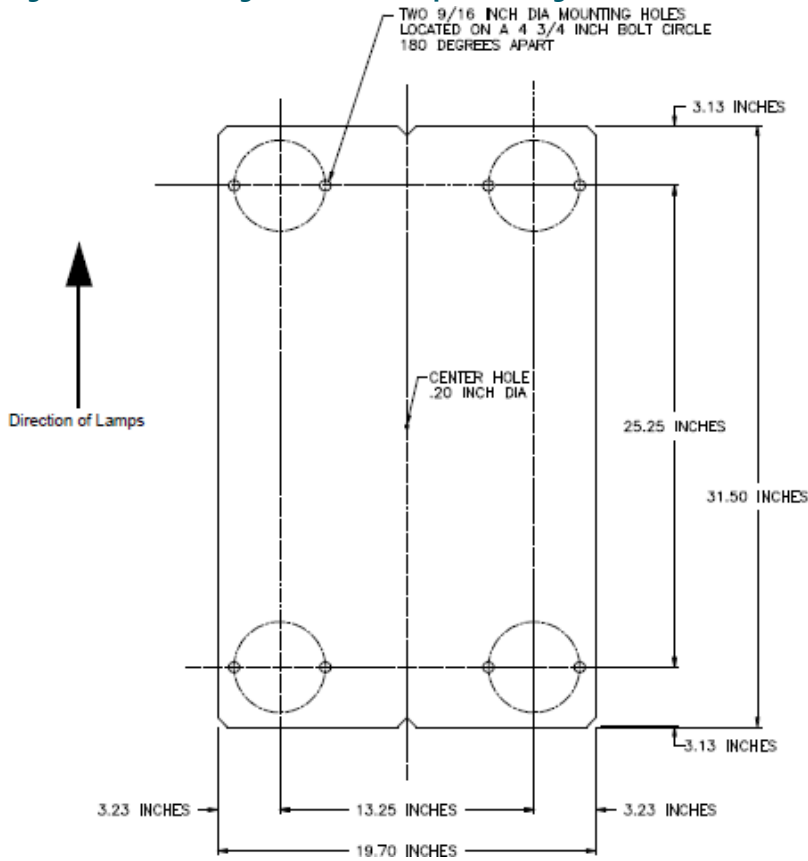

Figure 22: Positioning Plate (Three Lamps/Three Legs)

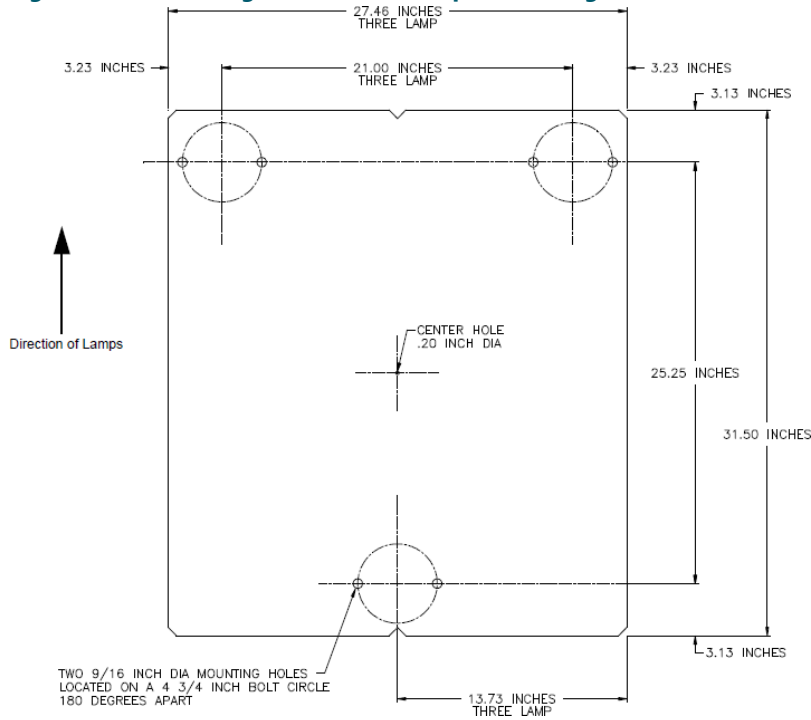
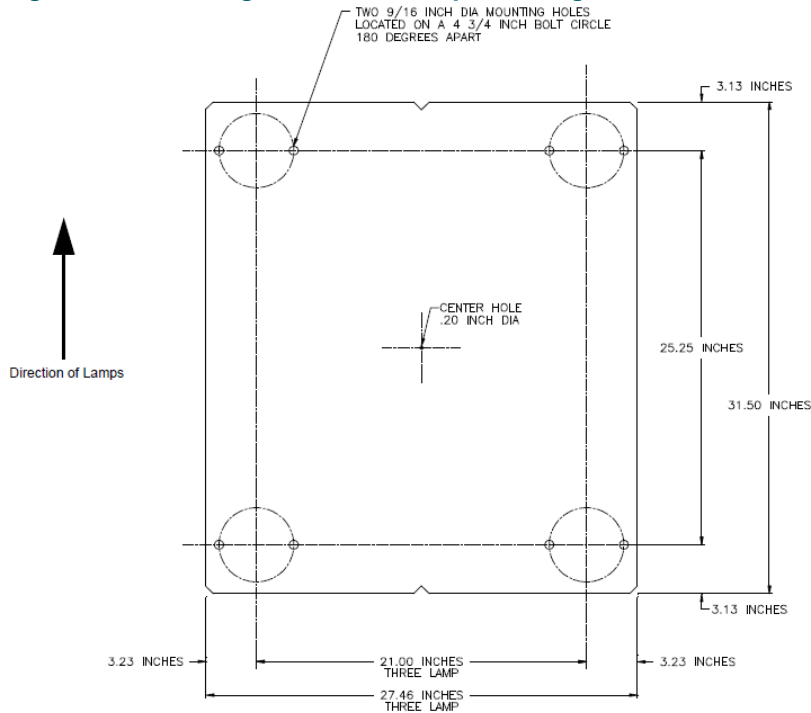

Figure 23: Positioning Plate (Three Lamps/Four Legs)



9. Install the frangible couplings. Make sure to place the second nut, ferrule compression joint, and ferrule ring on the bottom of the EMT tube first before screwing the tube with nuts, joints, and rings onto the frangible coupling. See [Figure 24](#).



Note

The contractor supplies and installs the 2-inch (50.8 mm) diameter (2-3/16 OD) EMT tube. Determine length at installation to adjust for uneven elevation above the runway.
The 2-inch EMT tube extends into the frangible coupling 3.25 inches (82.55 mm) and 1-1/2 inches (38.1 mm) into the nut and ferrule compression joint to ensure stable installation. Paint the tube according to Federal standard 595A, color #12197, international orange, to reduce corrosion.

Instead of expansion sleeves, cast 3/8-16 x 6-inch anchor j-bolts into the concrete at the proper locations on a 4 3/4 in. (120.65 mm) diameter bolt circle, in two places.

Figure 24: Frangible Coupling

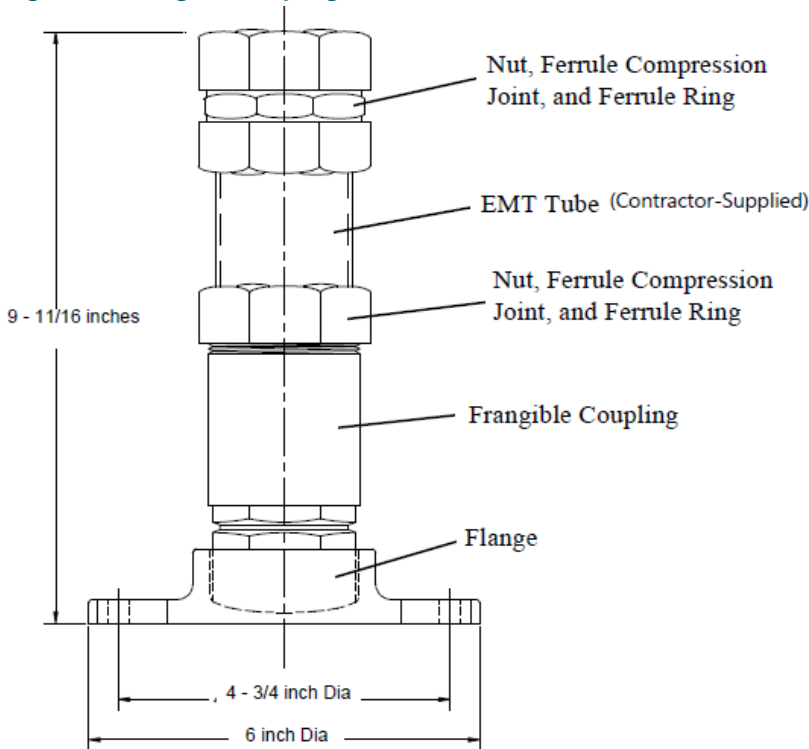

4.9 PAPI Aiming Angles

Refer to [Table 6](#) and [Table 7](#) for the aiming angles for the L-880 and L-881 PAPI light units.

Table 6: Aiming Angles for L-880 PAPI Units

L-880 (4 box) PAPI	Aiming Angle (Minutes of Arc) (Standard Installation)	Aiming Angle (Minutes of Arc) (Height Group 4 Aircraft* on Runway with ILS)	Note
Unit nearest runway	30' above glide path	35' above glide path	A
Next adjacent unit	10' above glide path	15' above glide path	A
Next adjacent unit	10' below glide path	15' below glide path	A
Next adjacent unit	30' below glide path	35' below glide path	A

NOTE A: Refer to [Table 5](#) in *Siting PAPI with ILS Glideslope* in this section.

Table 7: Aiming Angles for L-881 PAPI Units

L-881 (2 box) PAPI	Aiming Angle (Minutes of Arc) (Standard Installation)
Unit nearest runway	15' above glide path
Unit farthest from runway	15' below glide path

i Note 60 minutes of arc = one degree (60' = 1°).

4.10 Assembling Adjustable Legs

Assemble the legs for each PAPI unit as follows:

See [Figure 8](#). Screw threaded rods (5, 11) into differentials (7) and assemble legs.

i Note Do not assemble upper hex nut (1), upper split lockwasher (2), and upper flatwasher (13). These items will be installed after the PAPI unit is mounted on the legs.

Screw front and rear leg assemblies into the frangible couplings installed on concrete pad.

4.11 Mounting Unit

To mount the unit, perform the following procedure:

See [Figure 8](#). Gently mount PAPI unit on the three or four legs so that the unit rests on the top of the lower flatwasher (12), lockwasher (3), and hex nut (4).

i Note For the three-leg PAPI, assemble the upper end of the center rear leg as shown in Item 14 of [Figure 8](#). Make further adjustment of the leg height by using the PAPI differential (7).

See also [Figure 25](#) and [Figure 26](#) while mounting unit. [Figure 25](#) shows the two-lamp, four-leg PAPI. [Figure 25](#) shows the two-lamp, three-leg PAPI.

Figure 25: Elevation Setting Sequence (Two-Lamp, Four-Leg PAPI Shown)

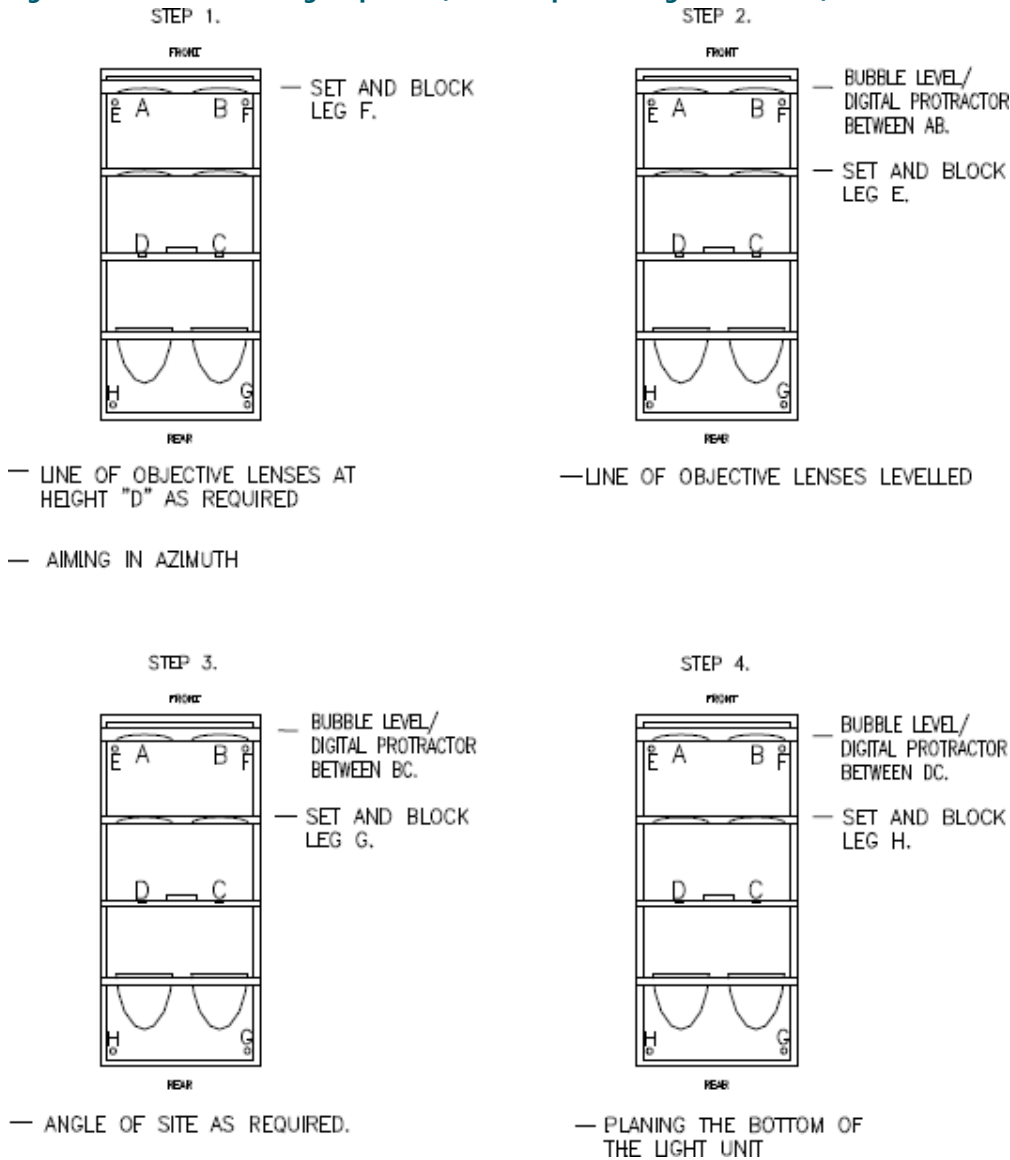
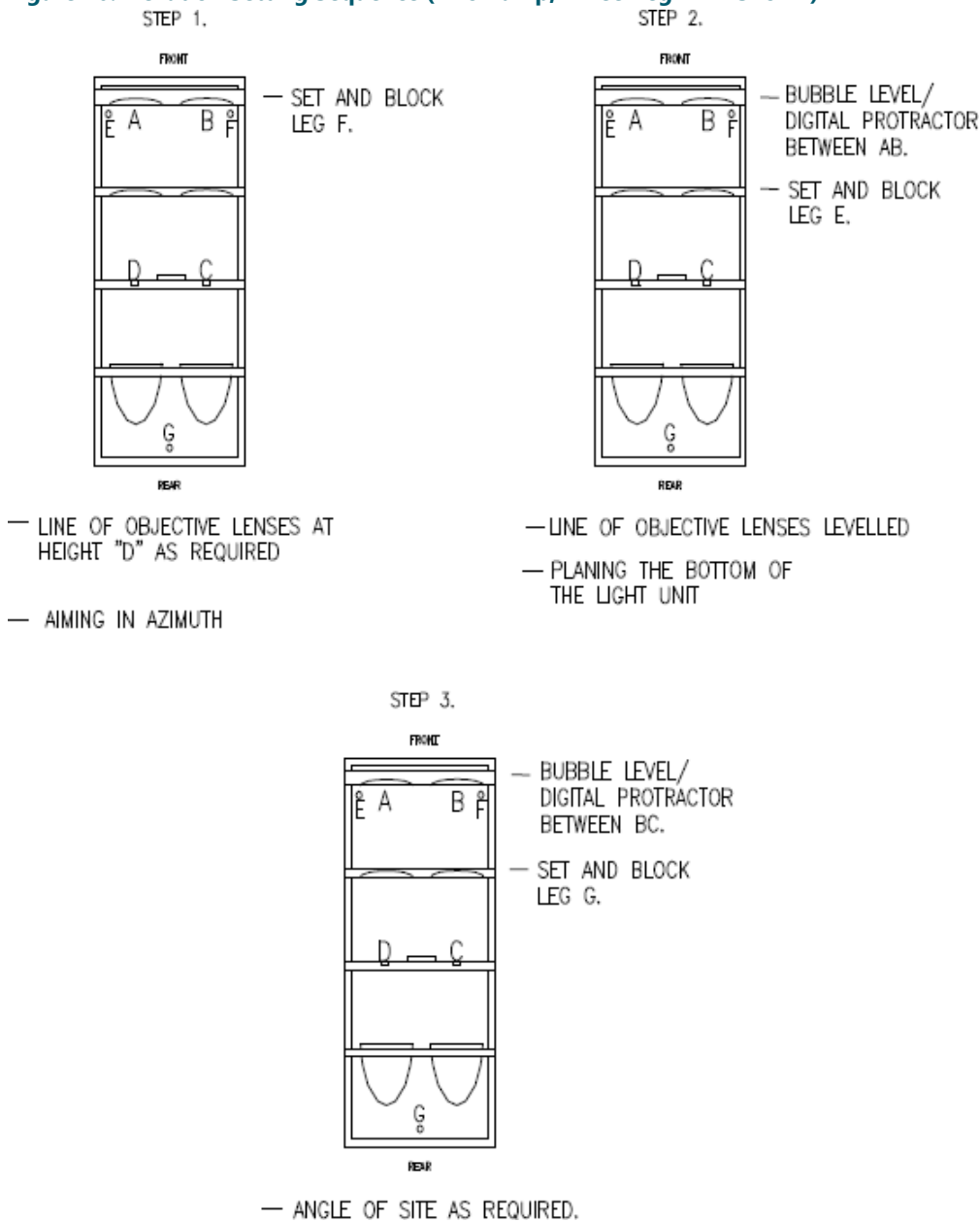

Figure 26: Elevation Setting Sequence (Two-Lamp, Three-Leg PAPI Shown)



See [Figure 8](#), install the upper flat washer (8), lock washer (1), and hex nut (10) on the threaded rod (3). Do not tighten nuts. Make sure the bottom of the unit is resting on the top of the lower flat washer (11) of the right front leg F.

Make sure all locking nuts on the frangible couplings are tightened.

4.12 Aligning Units

This subsection provides information for aligning the PAPI units using the two types of aiming devices: the bubble-level style and the digital-level style. Aligning the PAPI involves knowing how the two types of aiming devices work, using bubble-level or digital-level aiming device to align PAPI, and leveling the tilt switch.



Note

Alignment procedures are shown for the 2-lamp PAPI in [Figure 25](#) and [Figure 26](#), but the procedures apply to the 3-lamp PAPI as well.

4.12.1 How Bubble-Level Aiming Device Works

See [Bubble-Level Style Aiming Device](#) . The bubble-level aiming device has two graduated scales, a large metallic scale and a plastic scale (on the upper arm of the aiming device) which are used to set the aiming angle.

The **metallic scale** is calibrated in **10 minutes of arc** from 0° to 10°. Since there are 60 minutes of arc in one degree (60' = 1° or 30' = 1/2°), there are 6 divisions (0-10', 10-20', 20-30', 30-40', 40-50', 50-60') between each degree tic mark on the scale. Note the 30 minute or 1/2 degree tic mark between each degree tic mark (0 to 1°, 1 to 2°, 9 to 10°) on the metallic scale is slightly longer than the 10', 20' or 40' and 50' tic marks.

The **plastic scale** is calibrated in **minutes of arc** from 0 to 10 minutes. If an angular setting of, for example, 3° 30' is desired, the setting on the aiming device is obtained by moving the upper bar of the aiming device with the attached plastic graduate scale so that the *0 line on the plastic scale lines up exactly with the 3° 30' tic mark on the metallic scale* (the 30 minute (30') tic mark is midway between the 3 degree and 4 degree tic marks). After obtaining this setting, tighten the locking screw on the upper arm to secure the angular setting.

Suppose now that an angle of 3° 35' is desired. To obtain this setting, perform the following procedure:

Set the 0 line on the plastic scale at the 3° 30' tic mark as described above.

Locate the 5 minute line on the plastic scale. It will not be lined up with any of the tic marks on the metallic scale.

To obtain the desired setting of 3° 35', slowly move the 5 minute line upward until it lines up exactly with the next tic mark on the metallic scale. The 5 minute line on the plastic scale will be exactly lined up with the 4° 20' tic mark on the metallic scale when the aiming device is set for 3° 35'.



Note

The 0° line on the bottom of the plastic scale will be centered between 3° 30' tic mark and 3° 40' tic mark on the metallic scale. Tighten the locking screw on the upper arm to secure the arm's angular setting.

Practice using the aiming device to obtain the following angular settings: 3° 33' and 3° 38'.



Note

The 3° 33' angular setting is obtained when the 3 minute line on the plastic scale is lined up with the 4 degree tic mark on the metallic scale; the 3° 38' angular setting is obtained when the 8 minute line on the plastic scale is lined up with the 4° 50' tic mark on the metallic scale.

4.12.2 How Digital-Level Aiming Device Works

This subsection describes how the digital-level aiming device works. It provides information about the digital aiming device, how to calibrate the digital protractor, and how to install the digital protractor battery.

Digital Aiming Device



Note

Calibrate the digital-level before each use. See [Performing Digital Protractor Calibration Procedure](#)

See [Figure 11](#) and [Figure 12](#) . The digital-level aiming device has one survey device with two pivoting arms and a precision digital protractor that reads in 0.01 degree increments. Each 0.01 degree increment indicates a 0.6 minute movement.

The digital level reads directly in degrees with one hundredth (.XX) of a degree resolution. [Table 8](#) is provided to convert minutes to decimal of degrees.

Example: 3° 35' would read 3.58°.

3° 15' would read 3.25°.

Suppose now that an angle of 3° 33' is desired. To obtain this setting, perform the following procedure:

Set the digital leveling device on mounting points A, B, C, and D per [Figure 11](#) and [Figure 12](#) .

Aim the PAPI A box per the procedure on [Figure 25](#) or [Figure 26](#) as applicable.



Note

The digital level displays the precise angle at which the PAPI is aimed. In this case, 3° 33' converts to 3.55°.

A laminated card with the conversion chart is provided with each alignment device.

Table 8: Conversion from Decimal Degrees to Minutes

Minutes	Decimal Degrees	Minutes	Decimal Degrees
1	0.02	31	0.52
2	0.03	32	0.53
3	0.05	33	0.55
4	0.07	34	0.57
5	0.08	35	0.58
6	0.10	36	0.60
7	0.12	37	0.62
8	0.13	38	0.63
9	0.15	39	0.65
10	0.17	40	0.67
11	0.18	41	0.68
12	0.20	42	0.70
13	0.22	43	0.72
14	0.23	44	0.73
15	0.25	45	0.75
16	0.27	46	0.77
17	0.28	47	0.78
18	0.30	48	0.80
19	0.32	49	0.82
20	0.33	50	0.83
21	0.35	51	0.85
22	0.37	52	0.87
23	0.38	53	0.88
24	0.40	54	0.90
25	0.42	55	0.92
26	0.43	56	0.93
27	0.45	57	0.95
28	0.47	58	0.97
29	0.48	59	0.98
30	0.50	60	1.00

4.13 Calibrating Digital Protractor

Calibrating the digital-level style aiming device involves performing an accuracy test and if necessary, a calibration test for the digital protractor.



Note

Refer to *Operating Digital Protractor* in the *Operation* section for digital protractor operating instructions.



CAUTION

- To ensure accurate readings with the digital protractor, calibrate before use. It is also recommended to calibrate the digital protractor if it has been dropped or is being used in an environment that varies more than 5 °C (9 °F) from the environment in which it was last calibrated. Refer below for calibration instructions.

4.13.1 Performing Digital Protractor Accuracy Test

To perform the accuracy test for the digital protractor, perform the following procedure:

1. See [Figure 27](#) . Position the digital protractor with the display facing you on a clean, flat horizontal surface. It doesn't have to be exactly level. Wait ten seconds so the unit is completely settled and note the angle on the display.

Figure 27: Positioning Digital Protractor

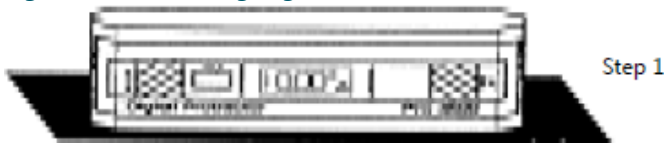

2. See [Figure 28](#) . Rotate the unit end-for-end so that the display is facing away from you. Be sure to set the digital protractor in exactly the same spot, and wait 10 seconds before reading the angle that is displayed.

Figure 28: Rotating and Rolling Protractor

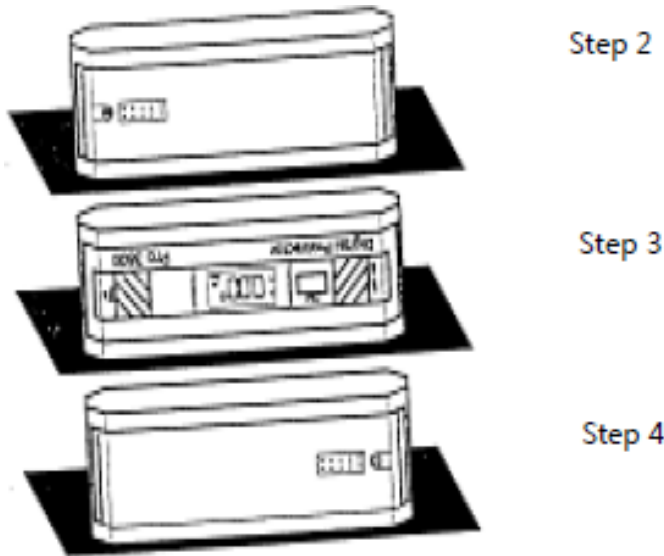

3. Now roll the unit forward so that that display is facing you, but the lettering on the face of the unit is upside down. Wait 10 seconds and note the angle on the display.
4. Rotate the unit end-for-end so that the display is facing away from you. The lettering should still be upside down. Wait 10 seconds and note the angle on the display.



CAUTION

- If any of the four measurements in steps 1 through 4 varies from any other by more than 0.1 degrees, you must recalibrate the digital protractor. Refer below for calibration procedure.

4.13.2 Performing Digital Protractor Calibration Procedure

The calibration procedure below calibrates the digital protractor through its entire 360 degree range by electronically recording four horizontal and four vertical settings. It should be performed whenever the accuracy test shows a discrepancy of 0.1 degrees or more.

Note You may cancel the calibration procedure at any time by turning off the digital protractor.

To calibrate the digital protractor, perform the following procedure:

1. Turn on the digital protractor and place it on a flat surface. You can use any horizontal surface within 10 degrees of level and any vertical surface within 10 degrees of plumb. You must use the same surfaces throughout the entire process.

Note Each time you reposition the digital protractor, wait a minimum of 10 seconds before pressing the HOLD button to advance to the next step.

2. See [Figure 29](#). Press and hold the HOLD and ALT ZERO buttons simultaneously. Keep them depressed for approximately three seconds.

Figure 29: Digital Protractor Displays and Buttons

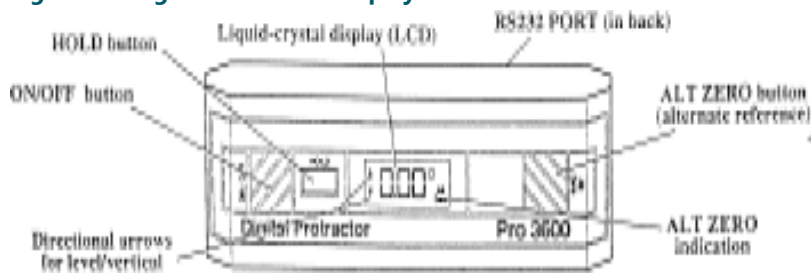

3. See [Figure 30](#). Release the buttons when the symbol "SUP" appears. A 0 within flashing brackets then appears. These brackets are composed of four horizontal and four vertical segments.

Note As you proceed through this procedure, a new segment will hold steady after you complete each step.

Figure 30: 0 within Flashing Brackets



4. Calibrate horizontal settings by performing the following procedure:
- See [Figure 31](#). Face the digital protractor toward you. The white lettering on the face should be right-side up. Align with an edge or line. Wait 10 seconds. Press the HOLD button until **[1]** appears.

Figure 31: Rotating and Rolling Digital Protractor for Horizontal Settings

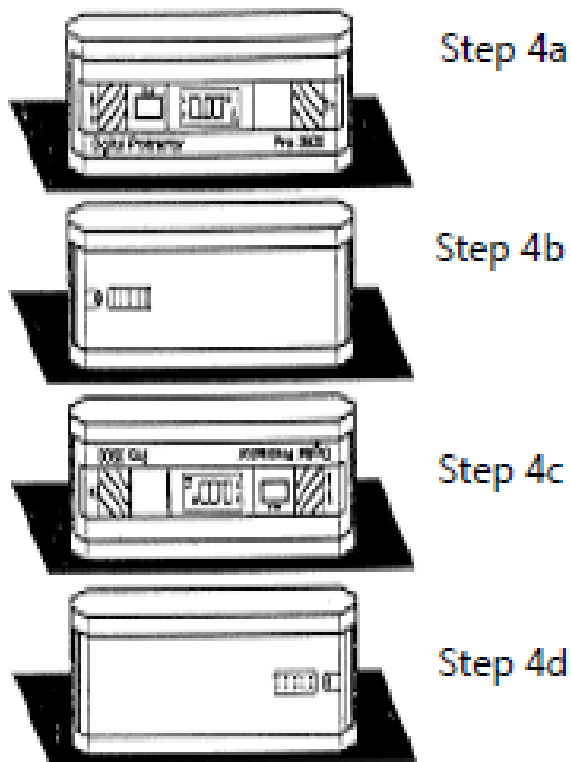

- Rotate the digital protractor so that it faces away from you. The lettering should still be right-side up. Align with the same edge or line. Wait 10 seconds. Press the HOLD button until **[2]** appears.

- c. Roll the protractor so that it faces you. The lettering should now be upside down. Align with the same edge or line. Wait 10 seconds. Press the HOLD button until **[3]** appears.
 - d. Rotate the protractor so that it faces away from you. The lettering should still be upside down. Align with the same edge or line. Wait 10 seconds. Press the HOLD button until **[4]** appears.
5. Calibrate vertical settings by performing the following procedure:
- a. See [Figure 32](#) . Place the digital protractor against a vertical surface so that it faces you. The lettering on the face should read from bottom to top. Align with an edge or line. Wait 10 seconds. Press the HOLD button until **[5]** appears.

Figure 32: Rotating and Rolling Digital Protractor for Vertical Settings

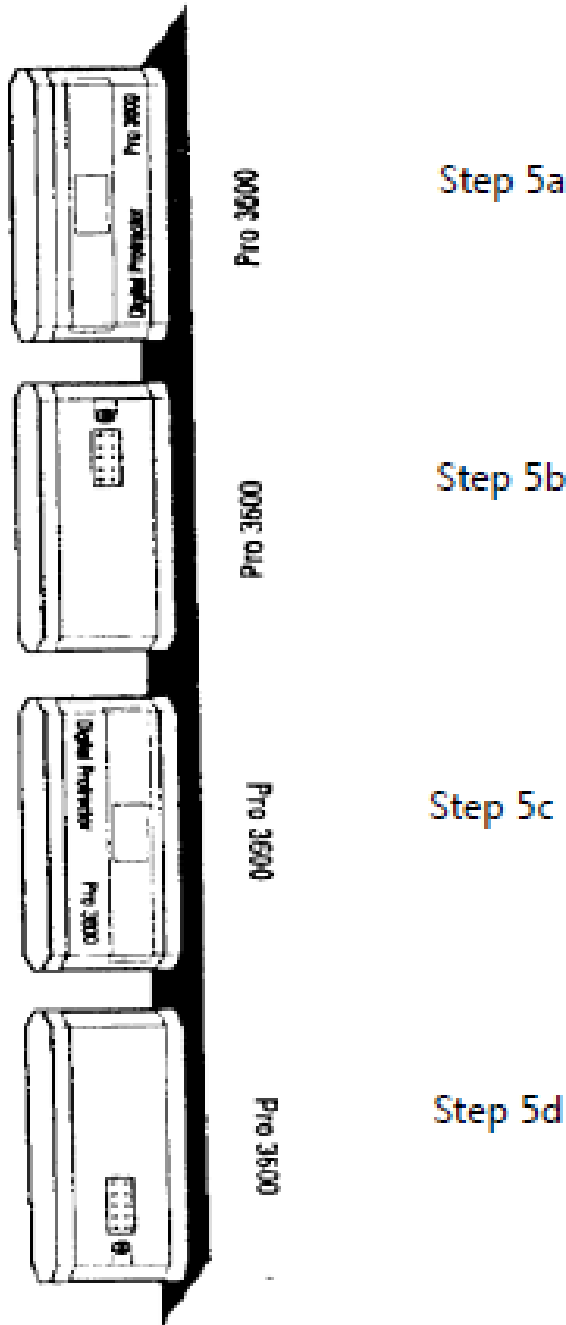

- b. Roll the digital protractor so that it faces away from you. The lettering should still read from bottom to top. Align with the same edge or line. Wait 10 seconds. Press the HOLD button until **[6]** appears.

- c. Rotate the digital protractor end-for-end so that it faces you. The lettering should now read top to bottom. Align with the same edge or line. Wait 10 seconds. Press the HOLD button until **[7]** appears.
- d. Roll the digital protractor so that it faces away from you. The lettering should still read top to bottom. Align with the same edge or line. Wait 10 seconds. Press the HOLD button until **[8]** briefly appears, followed immediately by regular angle measuring.

Installing Digital Protractor Batteries

See [Figure 33](#) for installing batteries.

Figure 33: Digital Protractor Installation

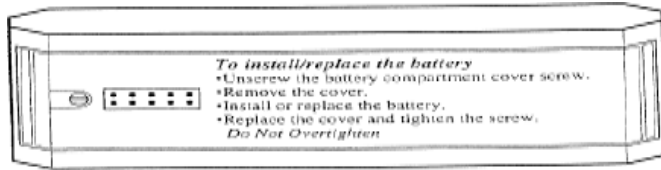

The digital protractor is powered by a 9-volt battery. A new alkaline battery provides 500 hours of use. A 9-volt lithium battery can be used for even longer life.

To extend battery life, the digital protractor shuts off automatically when left undisturbed for five minutes, unless activity exists on the serial port. To reactivate the digital protractor, push the ON/OFF button.



Note

Hooking serial port pin 5 (REQ) to pin 9 (BATT+) disables the auto-power shutoff. The digital protractor also indicates when the battery is low. Change the battery when the display alternately flashes "LobAt" with angle measurements.

The digital protractor does not display inaccurate angles due to a weak battery.

4.13.3 Aligning PAPI Using Bubble-Level/Digital-Level Aiming Devices

Using the bubble-level or digital-level aiming devices to align the PAPI units involves performing horizontal aiming, performing rough elevation setting, checking the horizontal aiming, and performing fine elevation setting.

Preliminary Remarks

The remarks below should be kept in mind in all the following operations: aligning horizontal cutoffs to aiming device, adjusting rough elevation setting, and checking horizontal aiming.

- When handling the unit and, in particular, during installation and aiming, avoid movement of the reference adjusting screws in blocks A and B.



Note

Any accidental movement of these screws will require resetting in the factory by specialized personnel.

- When placing the aiming device on the PAPI unit, make sure the holes and slots in the movable arms of the aiming device are properly inserted over the screw heads in the reference blocks (A and B) and into reference slots (C and D).
- The bubble level/digital protractor should be carefully positioned between the locator screws on the bar of the aiming device or against the locator screws on the movable arms.
- When working with the fastening nuts and locknuts on the legs, make sure that the threaded rod does not rotate.

Aligning Horizontal Cut-Offs to Aiming Device

See [Figure 25](#), Step 1 for the 4-leg PAPI and [Figure 26](#), Step 1 for the 3-leg PAPI. Horizontal cut-offs are aligned to the aiming device, not the PAPI box.

Note

The bubble-level style aiming device is set to the desired elevation setting (3 degrees, 15 minutes), then the PAPI unit is adjusted until the aiming device is level. For the digital-level style aiming device, the digital protractor reads the angular setting of the PAPI box directly. For more detail on the differences between the bubble-style and digital-style aiming devices, refer to Installation Using Bubble-Level Style Aiming Device and Installation Using Digital-Level Style Aiming Device in this section.

To align the horizontal cut-offs, perform the following procedure:

1. For the bubble-level style aiming device only, first set the aiming device at the required aiming angle for the unit.
2. Open up the two movable arms and place the instrument on the reference blocks A, B, and slots C and D as shown in [Figure 25](#) and [Figure 26](#) . Carry out the following aiming procedure:
 - a. Place rod at 164 feet (50 m) in front of the PAPI unit at the same distance from the runway centerline as reference block B and slot C.
 - b. Check the alignment through the V-sites on bar of aiming device. Use the sighting pictures given in [Bubble-Level Style Aiming Device](#) and [Bubble-Level Style Aiming Device](#) for the bubble-level aiming device and [Figure 10](#) and [Figure 11](#) for the digital-level aiming device. See [Figure 8](#) . If necessary, adjust alignment of unit by a small movement of the lower hex nut (4).
 - c. Tighten upper hex nut (13) on the right front leg F.
 - d. Do not tighten lower hex nut (10). Leg F will be the pivot during the following operations.

4.14 Adjusting Rough Elevation Setting

This subsection describes how to adjust the rough elevation for the 4-leg and 3-leg PAPI.

4.14.1 Adjusting Rough Elevation Setting for Four-Leg PAPI System

Note

If the legs of the unit are installed at the same height and are level, the unit will be aimed at approximately 3 degrees. To adjust the coarse setting of the 4-leg PAPI unit, perform the following procedure:

1. See Step 2, [Figure 25](#) . Place the bubble level/digital protractor between locator screws on the movable arm resting on reference blocks A and B.
2. See [Figure 8](#) and [Figure 25](#) . Level by adjusting the hex nuts (13, 10) on the left front leg E.
3. Tighten hex nuts (13, 10) simultaneously.
4. See Step 3, [Figure 25](#) . Place bubble level/digital protractor between locator screws on the bar of the aiming device resting on reference block B and slot C.
5. See [Figure 8](#) and [Figure 25](#) . Level by adjusting hex nut (6) of the right rear leg G. During this operation, the rigid bottom of the unit must be free from hex nut (13) on the left rear leg H.
6. Position upper hex nut (13) on leg G against upper flat washer (12). Simultaneously tighten hex nuts and on leg G.
7. See Step 4, [Figure 25](#) . Place bubble level/digital protractor between locator screws on the movable arm resting on reference slots C and D.
8. See [Figure 8](#) and [Figure 25](#) . Level by adjusting hex nut (10) on the left rear leg H. Some adjustment of the upper hex nut (13) may also be required.
9. Position hex nut on leg H against upper flat washer (12). Simultaneously tighten hex nuts (13,10).
10. Tighten lower hex nut (10) on leg F.

Note

No further adjustment is required on the hex nuts.

4.14.2 Adjusting Rough Elevation Setting for Three-Leg PAPI System



Note

If the legs of the unit are installed at the same height and are level, the unit will be aimed at approximately 3 degrees.

To adjust the coarse setting of the 3-leg PAPI unit, perform the following procedure:

1. See Step 2, [Figure 26](#) . Place the bubble level/digital protractor between locator screws on the movable arm resting on reference blocks A and B.
2. See [Figure 8](#) and [Figure 26](#) .
Level by adjusting the hex nuts (13, 10) on the left front leg E.
3. Tighten hex nuts (13, 10) simultaneously.
4. See Step 3, [Figure 26](#) . Place bubble level/digital protractor between locator screws on the bar of the aiming device resting on reference block B and slot C.

4.14.3 Adjusting Rough Elevation Setting for Three-Leg PAPI System

1. See [Figure 8](#) and [Figure 26](#) . Level by adjusting hex nut (6) of the right rear leg G.
2. Position upper hex nut (13) on leg G against upper flat washer (12). Simultaneously tighten hex nuts on leg G.
3. Tighten lower hex nut (10) on leg F.

Checking Horizontal Aiming

See [Figure 8](#) . Make sure rod at 164 feet (50 m) from the unit is still properly aligned with the V-sites on aiming bar. If not, loosen upper hex nut (13). Align the unit. Refer to "Aligning Horizontal Cut-Offs to Aiming Device" on page 49. Repeat the operations in the preceding section.



Note

It is not necessary for the alignment to be absolutely perfect. An error of 20 inches (508 mm) at 164 feet (50 m) yields an error of 0.5°, which is within tolerance. Refer to Azimuthal Aiming in Siting Tolerances in this section.

4.15 Adjusting Fine Elevation Setting

This subsection describes how to adjust the fine elevation setting for the 3-leg and 4-leg PAPI systems.

4.15.1 Adjusting Fine Elevation Setting for Four-Leg PAPI System

To adjust the fine elevation settings using the differential for the 4-leg PAPI, perform the following procedure:

1. Place aiming device on unit so that it rests on the screws of reference blocks A and B, and slots C and D.
2. See [Figure 25](#) , Step 1 and [Figure 8](#) . Make sure the locking hex nuts (5, 9) for the differential (4) on right front leg F are tightened. The locking hex nuts (5, 9) for the differentials on the other legs have to remain loose.
3. See [Figure 25](#) , Step 2 and [Figure 8](#) . Place bubble level/digital protractor on the arm of the aiming device resting on reference blocks A and B. Level by turning the differential on left front leg E in the proper direction. Tighten locking hex nuts (5, 9) on the differential on leg E when leveled.
4. See [Figure 25](#) , Step 3 and [Figure 8](#) . Place bubble level/digital protractor on the bar of the aiming device resting on reference block B and slot C. Proceed with the leveling procedure by adjusting the differential on rear legs G and H, turning both differentials in the same direction with equal amplitude. Tighten locking hex nuts (6, 8) on differential on leg G when leveling is completed.
5. See [Figure 25](#) , Step 4 and [Figure 8](#) . Place bubble level/digital protractor on the movable arm resting on slots C and D. Level by turning differential of left rear leg H in the appropriate direction. Tighten locking hex nuts on differential on leg H when leveling is completed.
6. Repeat the above fine elevation adjustment steps 2 through 5. If the setting is still not correct, go back and repeat the rough elevation adjustment steps and then the fine adjustment steps until the correct setting is obtained.

4.15.2 Adjusting Fine Elevation Setting for Three-Leg PAPI System

To adjust the fine elevation settings using the differential for the 3-leg PAPI, perform the following procedure:

1. Place aiming device on unit so that it rests on the screws of reference blocks A and B, and slots C and D.
2. See [Figure 26](#), Step 1 and [Figure 8](#). Make sure the locking hex nuts (5, 9) for the differential (4) on right front leg F are tightened. The locking hex nuts (5, 9) for the differentials on the other legs have to remain loose.
3. See [Figure 26](#), Step 2 and [Figure 8](#). Place bubble level/digital protractor on the arm of the aiming device resting on reference blocks A and B. Level by turning the differential on left front leg E in the proper direction. Tighten locking hex nuts (5, 9) on the differential on leg E when leveled.
4. See [Figure 26](#), Step 3 and [Figure 8](#). Place bubble level/digital protractor on the bar of the aiming device resting on reference block B and slot C. Proceed with the leveling procedure by adjusting the differential on rear leg G, turning both differentials in the same direction with equal amplitude. Tighten locking hex nuts (5, 9) on differential on leg G when leveling is completed.
5. Repeat the above fine elevation adjustment steps 2 through 4. If the setting is still not correct, go back and repeat the rough elevation adjustment steps and then the fine adjustment steps until the correct setting is obtained.

4.16 Installing Master Box Assembly

This subsection provides information for installing the master box assembly.

Locating Master Box

See [Figure 34](#). The master should be located behind the optical box #1 (the unit most distant from the runway) from 0 to 100 feet from the light unit. It should be located so that stray light from taxiing aircraft, rotating beacons, and automobiles does not energize the photocell on the unit.

Figure 34: Master Box Assembly

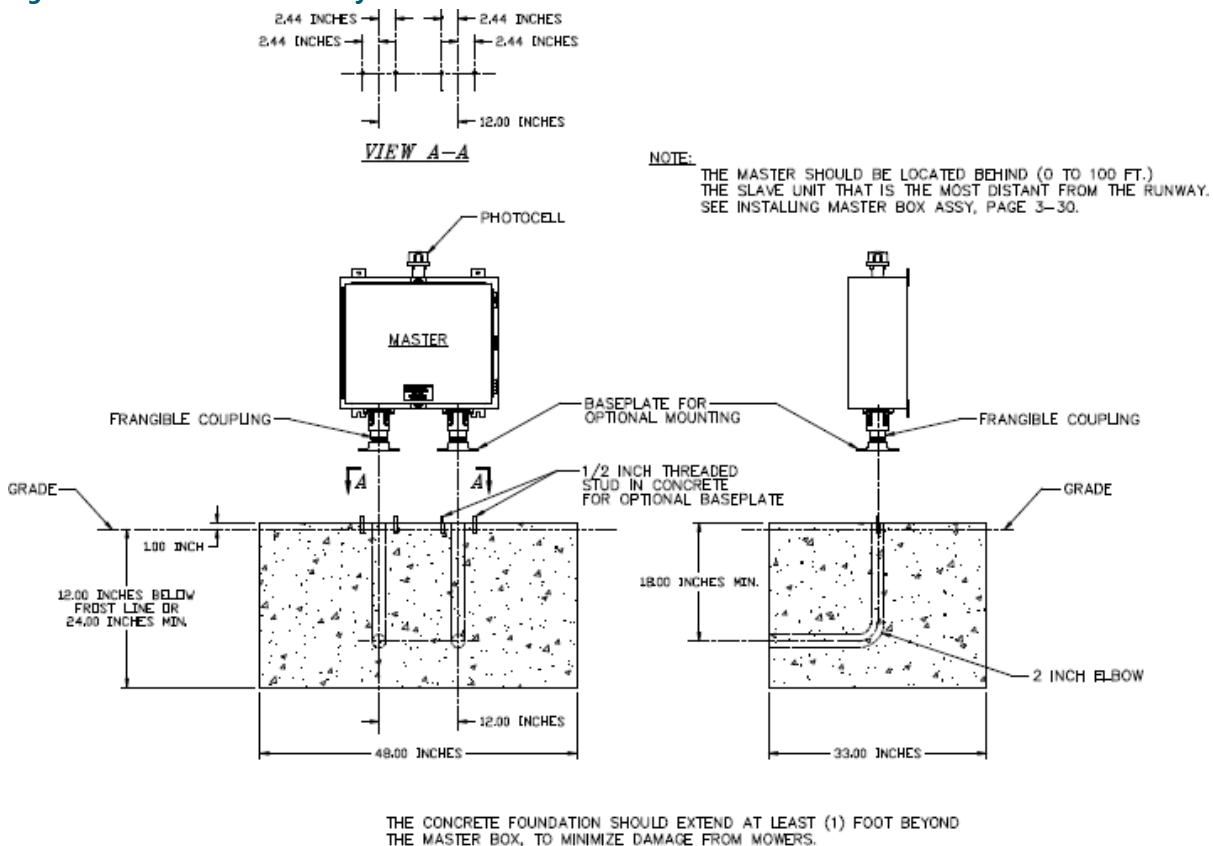

Preparing Master Foundation

To prepare the master foundation, perform the following procedure:

1. Dig, frame, and pour the foundation for the master per [Figure 34](#).
2. Install two-inch, 90 degree conduit elbows with couplings in the trench prior to pouring the concrete.
3. After the concrete has hardened, install frangible couplings in the two couplings on the concrete pad (optional baseplate with mounting studs can be used as shown).
4. Set the master unit on the frangible couplings and secure in place using the locking screws on the slipfitters on the bottom of the master unit.
5. Ground the master unit using AWG #12 ground wire.
6. See [Figure 44](#) and [Figure 45](#). Use external wiring diagrams to attach the appropriate field wiring to the labeled terminals of the master. See [Figure 51](#) and [Figure 51](#) for master internal wiring schematics.

4.16.1 Leveling Tilt Switches

To level the tilt switch, place a precision bubble level/digital protractor on top of the tilt switch (with metal plate attached to hold level). Loosen bolts and adjust the up/down position of the tilt switch until level reads true. Tighten the locking bolts.



Note

The bubble-level and digital protractor are located respectively in the Bubble-Type Level Aiming Device and Digital Protractor-Type Level Aiming Device Kit.



Note

Use a precision level such as the ± 0.004 in/ft degree of precision level used for leveling the PAPI units.

4.17 Wiring between Masters and Light Units



WARNING

- Before making any wire connections, make sure that you turn off the constant current regulator. Failure to observe this warning may result in personal injury, death, or equipment damage.

This subsection describes series circuit wiring requirements.

4.17.1 Grounding Units

Each PAPI unit must be grounded. To ground each unit: Attach a ground wire AWG #12 (minimum) to the ground lug located on the floor flange on the rear PAPI unit leg.

4.17.2 Connecting External Wiring

All installation wiring should conform to the applicable sections of the National Electric Code and Local Codes. Make wire connections as shown in [Figure 44](#) for the L-880 PAPI system or in [Figure 45](#) for the L-881 PAPI system. Route cable through the flexible conduit assemblies.



Note

All external wiring must be a minimum of 16 AWG/600 V.

See [Figure 35](#) and [Figure 36](#) for suggested method of connecting the wires between the master unit and the light box and the equipment that the contractor supplies. A field splice kit is available for L-880 installation and for L-881 PAPI installation. Each field splice kit provides enough items for entire installation. Refer to the *Parts* section for ordering information.



Note

It is important that the tilt switch wires be free from nicks and routed in such a manner as to minimize conducted interference between adjacent wires.



Note

After making all wiring connections and checking the operation of the units, install duct seal or RTV in all conduit entrances.

Figure 35: L-880/L-881 Master External Connections

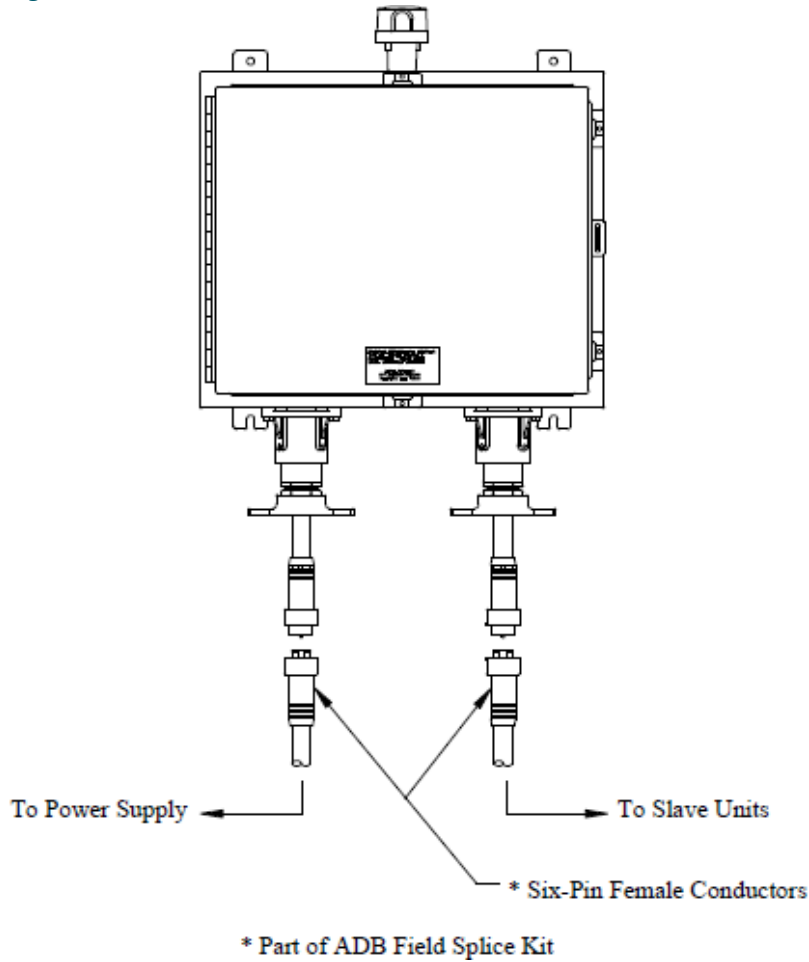
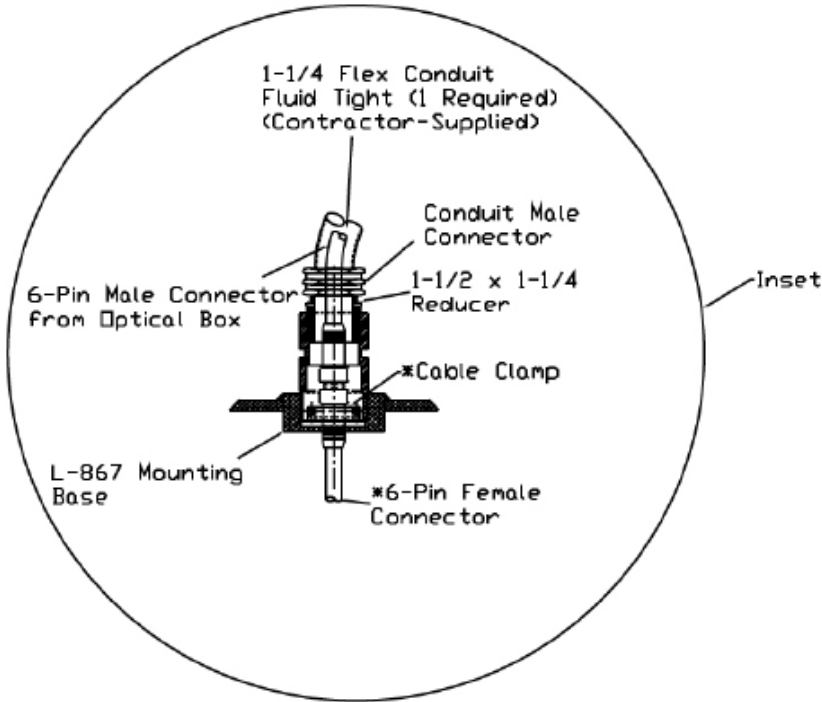
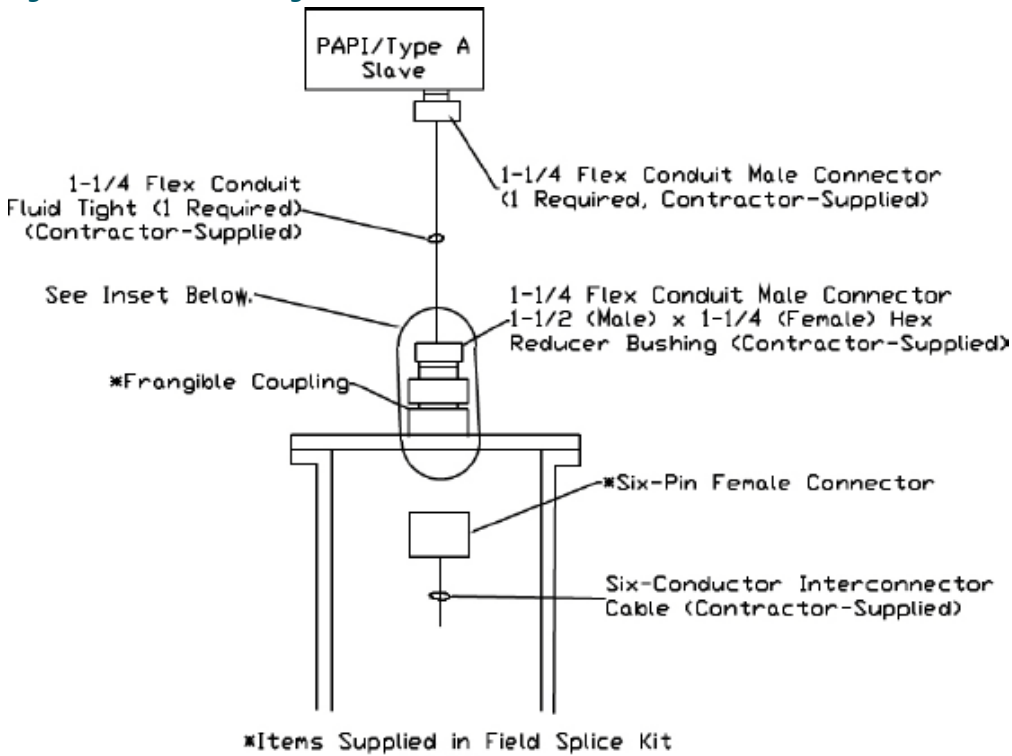

Figure 36: L-880/L-881 Light Box External Connections



4.18 Checking Slope Angles of PAPI Units

It may be requested that when the equipment is put initially into operation and at regular intervals thereafter, the cut-off angle of the units be checked. To make this measurement, it will be necessary to use a surveying instrument or a bubble level with telescope and a surveyor's stake.

To check the slope angles of the PAPI units, perform the following procedure:

1. See [Figure 37](#) . Place the surveying instrument 6 to 10 feet (1.83 to 3.05 m) behind the unit pointing down beam.

Figure 37: Checking Slope Angles

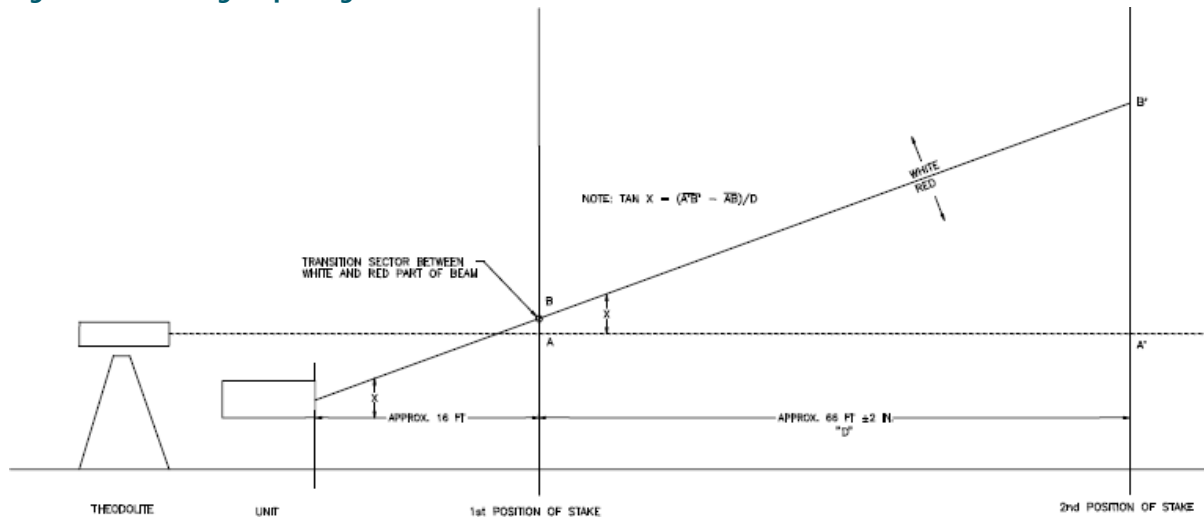

2. A surveyor's stake is held by an assistant approximately 16 feet (4.88 m) in front of the unit.
3. Take reading *A* for the intersection of the horizontal of the telescope with the stake.
4. Take reading *B* for the intersection of the cut-off plane of the light beam with the surveyor's stake.
5. The assistant should now move a precisely measured distance of about 50 to 66 feet (15 to 20 m) ($\pm 0.25\%$) down beam and take the same measurements *A'* and *B'*, as in steps 3 and 4 above.
6. The angle *x* of the beam cut-off to the horizontal is found from the following formula:

$$\tan x = \frac{A'B' - AB}{D}$$



Note

The overline (—) denotes length where *D* is the horizontal distance between the two stake positions. If similar checks are to be scheduled in the future, a small concrete pad holding a galvanized pipe may be installed in front of each unit at the distances used above.

4.19 Using Reference Bases for Checking Stick

See [Figure 10](#) . As soon as the system is found to be operationally acceptable in all respects, install permanent sighting bases in front of each light unit to allow for routine checks of the elevation setting using the checking stick.

4.19.1 Locating Reference Bases

To locate a reference bases, perform the following procedure:

1. Locate a concrete sighting base on the extended centerline of each unit.
2. When the PAPI is switched on, walk along the centerline of the unit observing it from time to time through the screen on the checking stick until the lower limit of the white sector is about to disappear under the lower scored line.
3. At this point, dig a hole approximately 16 inches (406.4 mm) square and 12 inches (304.8 mm) deep.
4. See [Figure 20](#) and [Figure 21](#) for the two-lamp/three- and four- leg positioning plate and [Figure 22](#) and [Figure 23](#) for the three- lamp/three- and four-leg positioning plate. Drive a steel pipe vertically in the center of the hole until its top is at ground level.
5. Place the bottom end of the checking stick on top of the pipe and observe the light unit through the screen.

6. Gradually drive the pipe into the hole, while frequently observing the light unit through the screen, until the light beam no longer appears completely white just below the upper line of the screen.
7. Repeat this procedure for the other units, using the same observer.

4.19.2 Making Observations with Checking Stick

See [Figure 10](#). Refer to *Reference Bases for Checking Stick* in this section. Place the checking stick on concrete sighting base in front of the light unit and switch the PAPI system on. Observe the light unit through the screen. Just below the upper line of the screen, the light beam should no longer appear completely white. If this is not the case, the unit is out of alignment and requires resetting. Refer to *Aligning Units* in this section.

4.19.3 Making Flight Checks for Reduced Horizontal Coverage

A flight check is required for the PAPI system when there is reduced horizontal coverage to determine if all horizontal cutoffs of the PAPI beams are properly located relative to any obstacles. If horizontal realignment is required, the upper and lower locknuts on all PAPI legs must be loosened and the unit realigned. Refer to *Aligning Horizontal Cut-Offs to Aiming Device* in this section.

5.0 Operation

This section provides operating information for the PAPI system and the aiming device digital protractor.

5.1 Operating PAPI System

This subsection provides information concerning PAPI normal operation, regions with heavy snowfall, criteria for system deactivation, initial startup using local control, REM control operation, and optional interlock relay.

5.1.1 Normal Operation

The PAPI system must operate continuously as long as the runway is in service. At night the system may operate continuously at either 5% or 20%. The nighttime intensity is set with a switch in the Master box.

5.1.2 Regions with Heavy Snowfall

Units should operate continuously at normal standby brightness even when the runway is not in use. Any snow will thus melt and drain off. When snowfall is expected to bury the units, the location of the units should be marked with sticks or flags (approximately 7 feet high) (2.13 m) to prevent damage to the units by snow removal equipment.

5.1.3 Criteria for System Deactivation

Pending repair and provided it is continually monitored, a unit in which one of the lamps has failed can still be regarded as operational. Should the system show more serious defects, it must be put out of operation.

5.1.4 Initial Startup Using Local Control

To turn on PAPI A using local control, perform the following procedure:

Verify that the PAPI Control Board jumper J9 is set to the 3-step setting. Short TB1-13 and TB-14 with 10 AWG wire, minimum. Connect a true RMS ammeter to this wire.

Place S1 to REM and turn circuit breaker CB1 to on.

Turn toggle switch S1 to LOCAL. The unit should turn on and the ammeter should read 6.6 A.

If the ammeter does not read 6.6 A, adjust the output current with buttons INC and DEC on the PAPI Control Board until the correct current is obtained. Press and hold the SAVE button for two seconds to save the setting.

Turn S1 to REM and CB1 to off.

Disconnect photocell by removing relay K2.

Turn CB1 to on and S1 to LOCAL. Unit should turn on.

Refer to [Table 9](#) . Turn toggle switch S2 to 20%. The ammeter should read 5.08A.

Table 9: Output Current

Intensity	Output Current
5%	4.09 A
20%	5.08 A
100%	6.6 A

If the ammeter does not read 5.08A, adjust the output current with buttons INC and DEC on the PAPI Control Board until the correct current is obtained. Press and hold the SAVE button for two seconds to save the setting.

Turn toggle switch S2 to 5%. The ammeter should read 4.09A.

If the ammeter does not read 4.09A, adjust the output current with buttons INC and DEC on the PAPI Control Board until the correct current is obtained. Press and hold the SAVE button for two seconds to save the setting.

Turn S1 to REM and CB1 to off. Install relay K2, and place S2 to 5% or 20% intensity for nighttime operation. Remove wire between TB1-13 and TB1-14 and re-apply field load.

Turn CB1 to on and S1 to LOCAL. The system should energize and all lamps should come on.

With the load applied, verify all current steps are correct. Re-adjust if necessary.

5.1.5 Remote Control Operation

To set Remote control, perform the following procedure:

When the toggle switch S1 is set to REM and remote control wiring is connected to TB1-7 and TB1-8. The system should energize and the ammeter should read 6.6 A. All lamps should come on.

Turn CB1 to off and disconnect photocell by removing relay K2.

Turn CB1 to on. The system should energize, all lamps should come on, and the ammeter should read corresponding to setting of S2.

Turn CB1 to off and install relay K2.

Turn CB1 to on.

5.1.6 Optional Interlock Relay

To test interlock relay operation, perform the following procedure:

1. Turn S1 to REM and CB1 to off.
2. Remove relay K2.
3. Turn CB1 to on.
4. Unit should remain off.
5. Turn on CCR that control the interlock relay.
6. Unit should turn on and all lamps should come on, and current to lamp should read corresponding to setting of switch S2.
7. Turn CCR off, unit should turn off.
8. Turn CB1 to off and install relay K2. Turn CB1 to on.

5.2 Operating Digital Protractor

This subsection provides information for operating the digital protractor. The digital protractor is a part of the digital-level style aiming device. For more information on calibrating, maintaining, installing, and using the digital protractor, refer to [Calibrating Digital Protractor](#) and "Installing Digital Protractor Batteries ", and [Maintenance Procedures](#) .



Note

Calibrate the digital-level before each use.

See [Calibrating Digital Protractor](#) .

To operate the digital protractor, perform the following procedure:

See [Figure 29](#) . Push the ON/OFF button. The digital protractor displays angle readings immediately.



Note

See Figure 38 . When the unit is first turned on, the displayed angles are in standard reference mode. The true horizontal level is displayed as 0.00°. An arrow on the left side of the display indicates which way to move the digital protractor to achieve level or plumb.

Figure 38: Digital Protractor Initial Angle Displayed

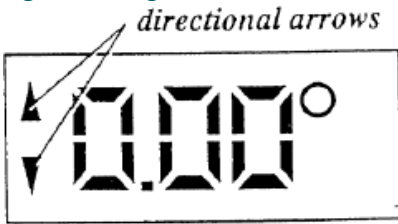

Set the digital protractor on the surface to be measured and read the angle.



Note

To get the most accurate reading, allow the unit to settle for 5 seconds before noting the angle.



Note

Expect a resolution of one hundredths of a degree for ±10 degrees of level. The resolution automatically changes to tenths of a degree beyond these points.

6.0 Maintenance

This section provides maintenance information for the L-880/L-881 PAPI systems.

6.1 Maintenance Schedule

Refer to [Table 10](#) for L-880/L-881 maintenance schedule.

Table 10: PAPI Maintenance

Interval	Maintenance Task	Action
After initial installation (during first few weeks)	(1) Check elevation angle of units.	(1) For the bubble-level style aiming device only, use that checking stick that comes in the Bubble- Type Level Aiming Kit. Reset any units out of alignment.
		(2) For the digital-level style aiming device, check the digital protractor calibration and verify the unit elevation aiming with aiming device and digital protractor located in the Digital Protractor-Type Level Aiming Kit.
Daily	(1) Check for frost or dew on outer lens if units are not operated continuously.	Remove frost or dew and change airport lighting circuitry per Cert Alert 02-08. See NTSB Cert Alert FAA Cert Alert No. 02-08 in Section 1
	(2) Check to ensure all lamps are lighted and illuminated evenly.	(1) Replace burned-out lamps. Clean any dirty glassware.
	(3) Check for any apparent evidence of damage to unit.	(2) Repair or replace any damaged components.
	(4) Check all control equipment for proper operation.	(3) Repair or replace any damaged components.
	(5) If using the aiming device with digital protractor, check the accuracy of the digital protractor. Calibrate the digital-level before each use. See Calibrating Digital Protractor	(4) Perform the digital protractor end-for-end accuracy test to make sure the digital protractor is in calibration. If the digital protractor is not accurate, perform the digital protractor calibration test. Refer to <i>Performing Accuracy Test</i> and <i>Performing Calibration Procedure</i> in the <i>Installation</i> section.
Weekly (more frequently during rainy season)	(1) Clean outer surface of protective glass.	(1) Use a soft cotton cloth moistened with alcohol.
	(1) Check elevation angle of units.	(1) For the bubble-level style aiming device only, use that checking stick that comes in the Bubble- Type Level Aiming Kit. Reset any units out of alignment.
	Calibrate the digital-level before each use. See Calibrating Digital Protractor	For the digital-level style aiming device, check the digital protractor calibration and verify the unit elevation aiming with aiming device and digital protractor located in the Digital Protractor-Type Level Aiming Kit.

Table 10: PAPI Maintenance (Continued)

Interval	Maintenance Task	Action
Monthly	(1) Inspect housing and closure system, lamps, electrical connections, filters, and protective glass for damage, breakage, or warpage.	(1) Repair or replace any damaged parts.
	(2) Clean interior.	(2) Remove any foreign matter. Clean both sides of the protective glass, color filters, lenses and reflectors. Use a soft cotton cloth moistened with alcohol.
	(3) Make sure mounting is rigid.	(3) Tighten any loose hardware, nuts, screws, etc. Realign unit if hardware has loosened.
	(4) Make sure no vegetation obscures the light beams.	(4) Remove vegetation. Use weed killer to prevent any additional growth.
	(5) Make flight check of system, if possible.	(5) Verify that units give proper approach path indication.

6.2 Maintenance Procedures

Refer to maintenance procedures below.

6.2.1 Replacing Lamp

To replace a lamp, perform the following procedure:

1. Turn off circuit breaker CB1.
2. De-energize main input breaker.
3. Disconnect the electrical slip-on fitting on burned-out lamp, swing back the spring-loaded fork and remove lamp from the reflector.



Note

Replacement lamps shipped after May 1, 2005 will include extra male disconnects. Replacement lamp(s) 48A0077-1 will have female disconnects. If the lamps being replaced have male disconnects, then the female disconnects on the power leads must be cut off and replaced with the male disconnects supplied in the Replacement Lamp Kit (94A0337). If the lamps being replaced have female disconnects, then disconnects on the power leads do not need to be replaced.

4. Reverse Step 1 to install a new lamp.
5. Orientate lamp to match index slots in lamp base with index tabs in lamp holder (one tab/slot is square, the other tab/slot is circular). Hold lamp in place by placing the forked spring clip over lamp base and locking spring clip in place by latching forked spring clip behind the locking ears located on side of lamp holder.



CAUTION

- Wear cotton gloves when handling the lamps. Touching the quartz bulb with bare fingers may seriously shorten lamp life. If the quartz bulb has been touched, wipe it carefully with lens cleaning tissue or similar material moistened with isopropyl alcohol.



Note

It is recommended that a systematic replacement of all lamps be made after a service period of approximately 800 hours at the 100% brightness level. An elapsed-time recorder connected to the constant current regulator may be used to determine the time for replacement.

6.2.2 Replacing Objective Lens

The objective lenses are precisely positioned in the unit and are not field repairable since the optical center of the lens must be realigned after replacement. Whenever an objective lens is damaged, the PAPI light unit must be returned to the factory for repair and adjustment. Contact ADB SAFEGATE, Inc. Sales Department for details.

6.2.3 Replacing Filters

The filters must be perfectly clean. Use a soft cotton cloth moistened with alcohol to clean filters, and wear cotton gloves when handling filters.

Each filter is held in place in the filter holder by two springs.

To remove or replace a filter, perform the following procedure:

1. Remove the two springs using a small pliers.
2. Unclip the lower end of each spring from the hole in the panel and pull upward on the other end of the spring to remove.
3. Remove the filter by sliding it upward out of the holder.
4. To reinstall filter, reverse the removal steps. The filter must be installed in the holder so that the lower edge (dull edge or machine edge) of the filter is down.



Note

When cleaning filters, make sure each filter is returned to the same filter holder from which it was removed.

Figure 39: Filter

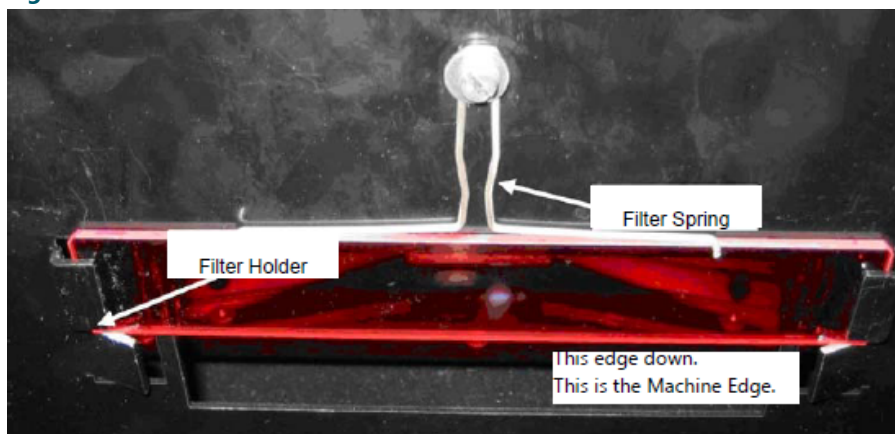

6.2.4 Cleaning and Storing Digital Protractor

Refer to the guidelines below for cleaning and storing the digital protractor used for aiming the PAPI.

- Clean the digital protractor with mild liquid soap applied to a damp cloth.
Never immerse the protractor in water.
- Do not use solvents directly on any of the digital protractor plastic surfaces.
- Store the digital protractor away from extreme temperature.



CAUTION

Equipment Damage

- Never store digital protractor below $-20\text{ }^{\circ}\text{C}$ ($-4\text{ }^{\circ}\text{F}$) or above $65\text{ }^{\circ}\text{C}$ ($149\text{ }^{\circ}\text{F}$)

7.0 Troubleshooting



WARNING

Electric Shock

- Allow only qualified personnel to perform the following tasks. Observe and follow the safety instructions in this document and all other related documentation.
- De-energize the circuit and lock out the circuit or regulator so that the circuit cannot be energized by remote means before attempting to service the fixture.

This section provides troubleshooting procedures.



Note

As of 12/4/01, the tilt switch assembly for the PAPI A is internal only. Before 12/4/01, the tilt switch was external.

7.1 Troubleshooting

Refer to [Table 11](#). This section describes preliminary troubleshooting and provides a basic troubleshooting table.

To do preliminary troubleshooting for the PAPI, perform the following procedure:

1. Check all fuses and circuit breaker.
2. Visually examine all areas of the PAPI. Check for burnt or loose connections and parts.
3. Check that input voltage is present and within +10% to -5% of nominal.
4. If the PAPI works in LOCAL but not in REMOTE, check voltage on the remote control lines. Check fuse F3. If voltage on remote control lines is correct and fuse F3 is normal, replace LC-control PCB1.
5. Turn toggle switch S1 from REM to LOCAL to check if the PAPI can be re-energized. If the PAPI re-energizes, the cause of the problem is an open circuit or over-current. Check the output wire for open circuit. If the output wire is closed, check over-current by calibrating LC-control PCB.
6. If open circuit exists, short the PAPI output with an AWG 8 (2000 volts, minimum) wire between TB1-13 and TB1-14 on the master, and turn on the PAPI. If the PAPI operates normally, the problem may be load related. Repair the PAPI output wire from the master to the individual light unit.
7. If the PAPI turns on for a few seconds and then shuts off and the the ammeter indicates 0 amps, the problem is either an open circuit, or current transformer T2 is open.
Replace transformer T2.
8. If the PAPI turns on and then shuts off after a few seconds and a high current reading exists on the the ammeter, the problem is an over-current. Adjust the output current accordingly.

If this does not work, replace LC-control PCB1 and then SCRs.

9. If the PAPI does not energize at all, check for under-voltage. If under-voltage exists, correct the under-voltage problem.

Table 11: L-880/L-881 PAPI Troubleshooting

Problem	Possible Cause	Solution
All lamps out	PAPI unit tilts	Realign PAPI unit.
	Tilt switch not level	Realign tilt switch.
	Power input	Repair or replace loose or broken wire.
	All lamps failed	Replace lamps. Check output current level. Calibrate, if necessary.
	LC-control PCB1 in master failed	Replace PCB1.
	SCRs failed	Replace SCRs.
	Fuses burned	Check all fuses. Replace blown fuses. If F4 is blown multiple times check that there are no ground faults in the output cables connected to the PAPI boxes. Ground faults must be repaired for proper PAPI operation.
	Shorting device PCB in light box bad	Replace shorting device PCB.
Lamp(s) dim	Dirty lens shield	Clean with soft cotton cloth moistened with alcohol.
	Lamp not properly seated in reflector	Re-seat lamp in reflector. Replace lamp socket, if necessary.
	Current level too low	Calibrate, if necessary.
	Lens is improperly aligned	Replace lens if loose in ring.
	Unit improperly aligned	Use check stick to check alignment.
Signal Interruption when PAPI unit is not operated continuously	Frost or Dew on outer lens	Change airport circuitry to ensure PAPI's are preset to operate on a low power setting of either 5 or 20 per cent. See FAA "CERT ALERT" on page iv.
Short lamp life	Current level too high	Check output current level. Calibrate, if necessary.
Tilt switch circuitry tilted	Tilt switches incorrectly wired	Correct wiring.
Interlock relay not operating	CCR is off Interlock relay not calibrated properly	Turn CCR on. Calibrate interlock relay by adjusting CS1 in master unit.
T1 Failure	Varying load on T1	Replace Power Core transformer (T1) and add 250V, 1A SLO-BLO fuse to protect (T1) if PCB does not have F4. See Parts List F4 and T1.

Figure 41: 43A2204

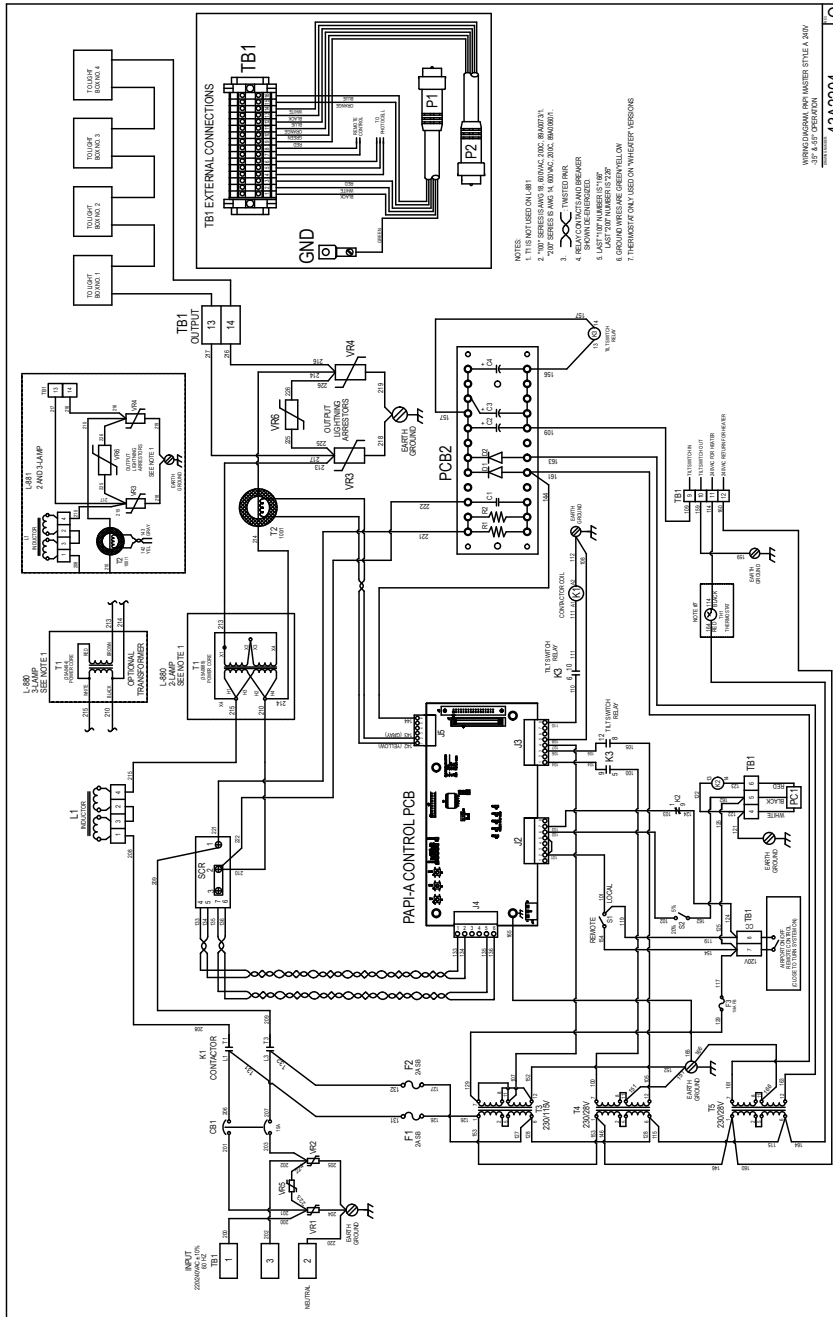

Figure 43: PAPI Installation, 117A0011 sht 1

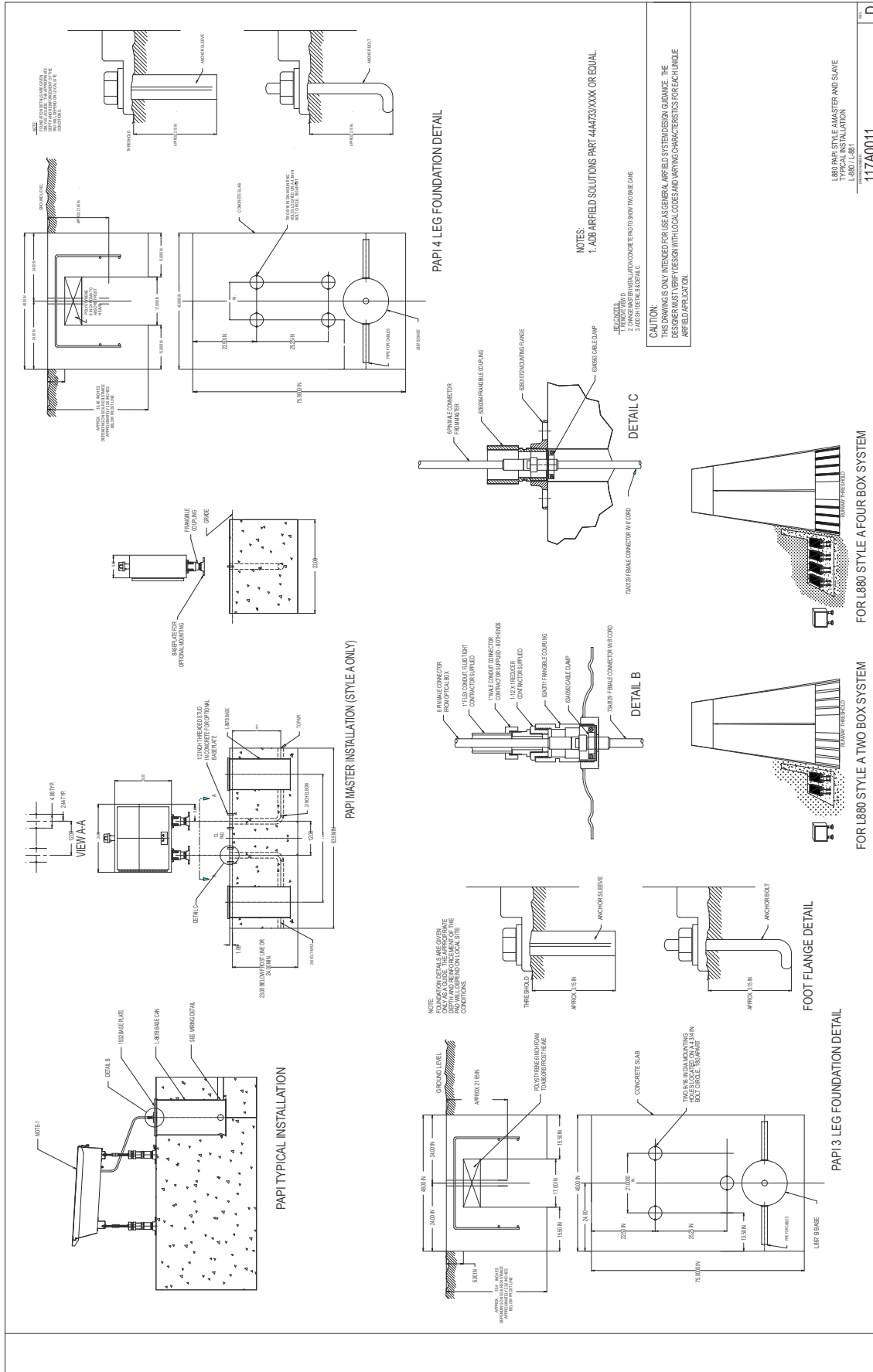

Figure 44: Two-Lamp PAPI Light Box Internal Wiring Schematic

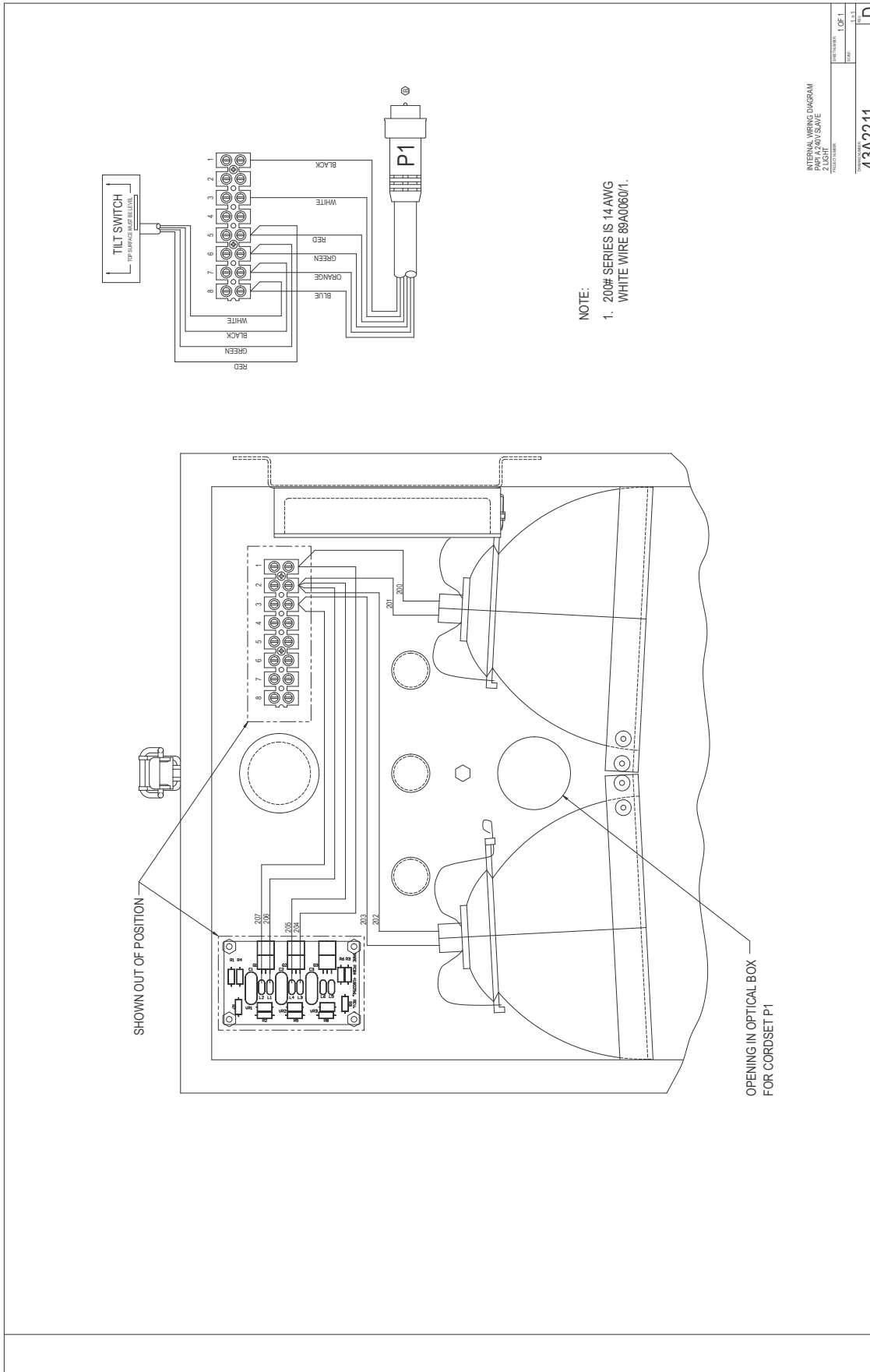
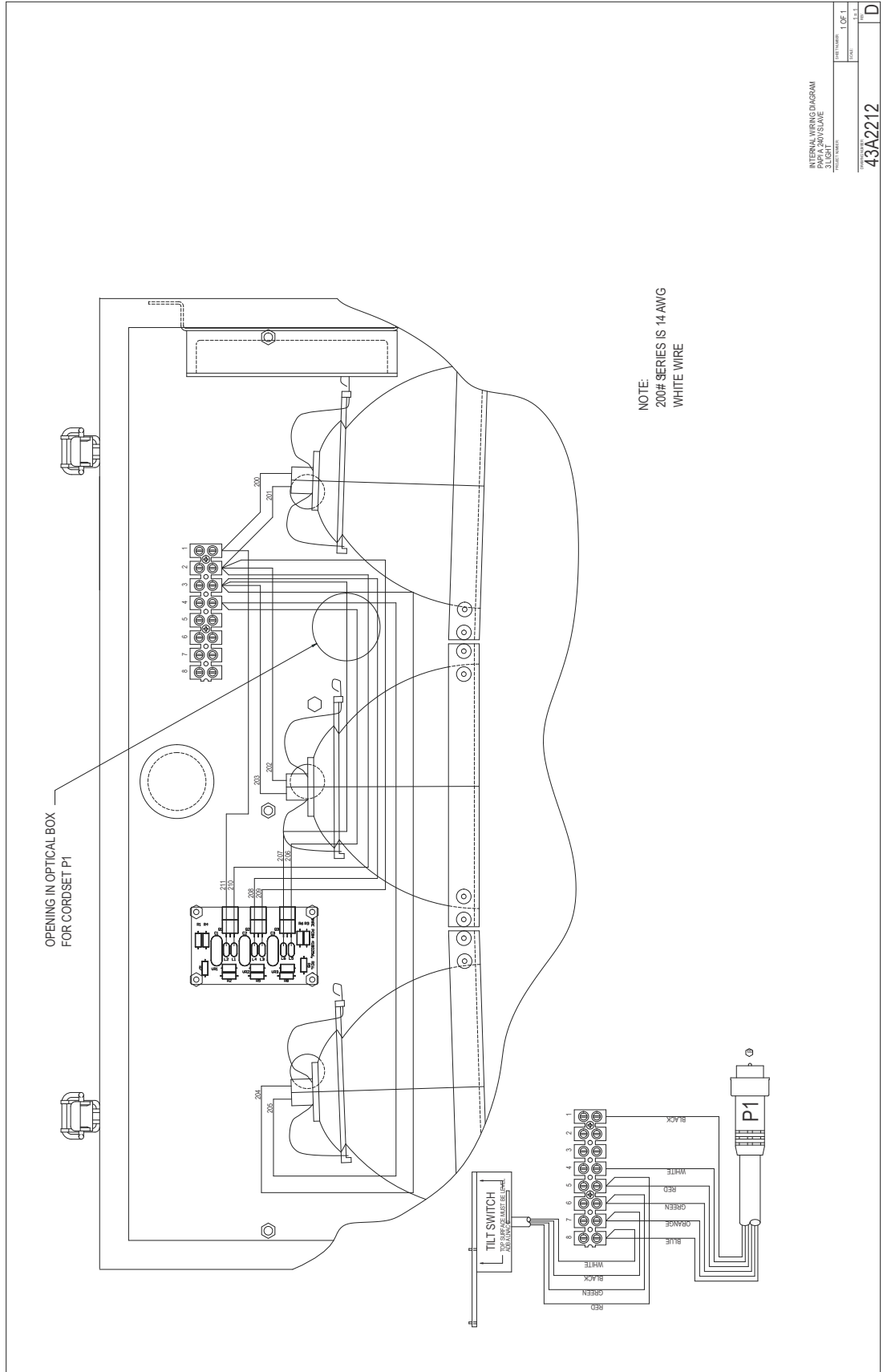

Figure 45: Three-Lamp Light Box Internal Wiring Schematic



8.0 PAPI A Parts

To order parts, call ADB SAFEGATE Customer Service or your local representative.

Ordering Code PAPI Style A 4 4 A 4 7 3 3 /

Style

1 = L-880 (4 Box)

2 = L-881 (2 Box)

Interlock Options

1 = With Interlock Relay

2 = Without Interlock Relay

Lamp

1 = 3-Lamp Optical Box

2 = 2-Lamp Optical Box

Legs

1 = Three Legs

2 = Four Legs



Notes

- Each PAPI system requires a digital aiming device kit, which is ordered separately.
- Interlock Relay Option provides ON/OFF control through current sensing of the runway series circuit during nighttime operations. During daytime, the PAPI is activated at the 100% step.
- Reference NTSB Cert Alert No. 02-08 dated Dec. 12, 2002, regarding prevention of the possibility of dew or frost forming on the light unit optics: At airports where PAPI units are activated when needed and thus are not operated continuously, change airport lighting circuitry to ensure PAPIs are preset to operate continuously on a low power setting, either 5 percent or 20 percent of full intensity as necessary for local site conditions.

Ordering Code Digital Aiming Device 44A6031

8.1 L-880/L-881 Style A Part Numbering System

Refer to [Table 12](#) and [Table 13](#) for all replaceable parts for each replaceable component or assembly for the L-880 and L-881 Style A PAPI systems.

[Spare Parts](#) shows how to determine the part number for a particular L-880/L-881 PAPI system.



Note

Substitution of electrical components may be done only if substitution is the exact physical equivalent (body or case size) and equal, or better electrical characteristics with respect to tolerance, failure rate, and/or reliability.

Table 12: L-880 PAPI System

Component	Part Number
Master box assembly	44A4734-1XXX
Light box #1	44A4735-XXX
Light box #2	44A4735-XXX
Light box #3	44A4735-XXX
Light box #4	44A4735-XXX

Table 13: L-881 PAPI System

Component	Part Number
Master box assembly	44A4734-2XXX
Light box #1	44A4735-XXX
Light box #2	44A4735-XXX

8.2 Optical Box Final Assembly Parts List

Figure 46: Optical Box Parts and Details

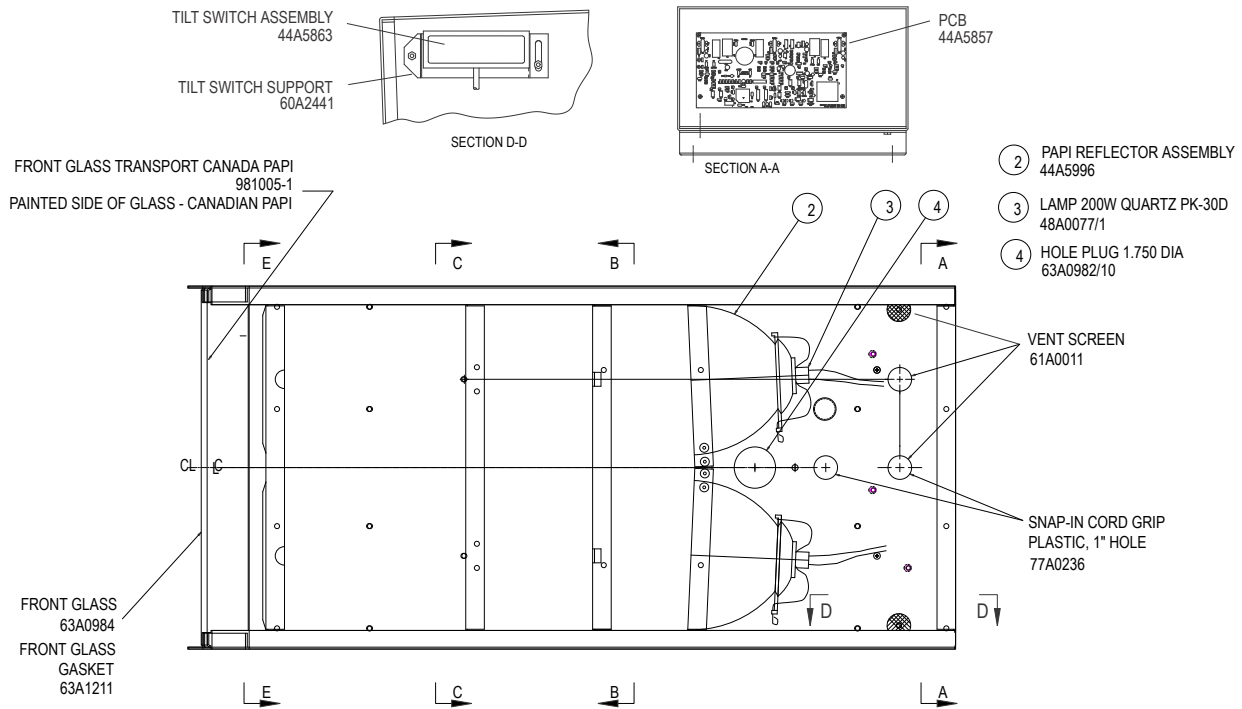

Figure 47: Optical Box Part Detail B-B

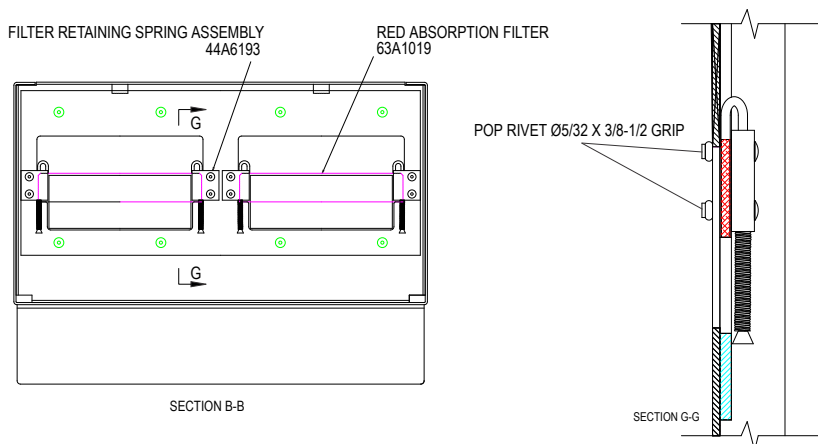
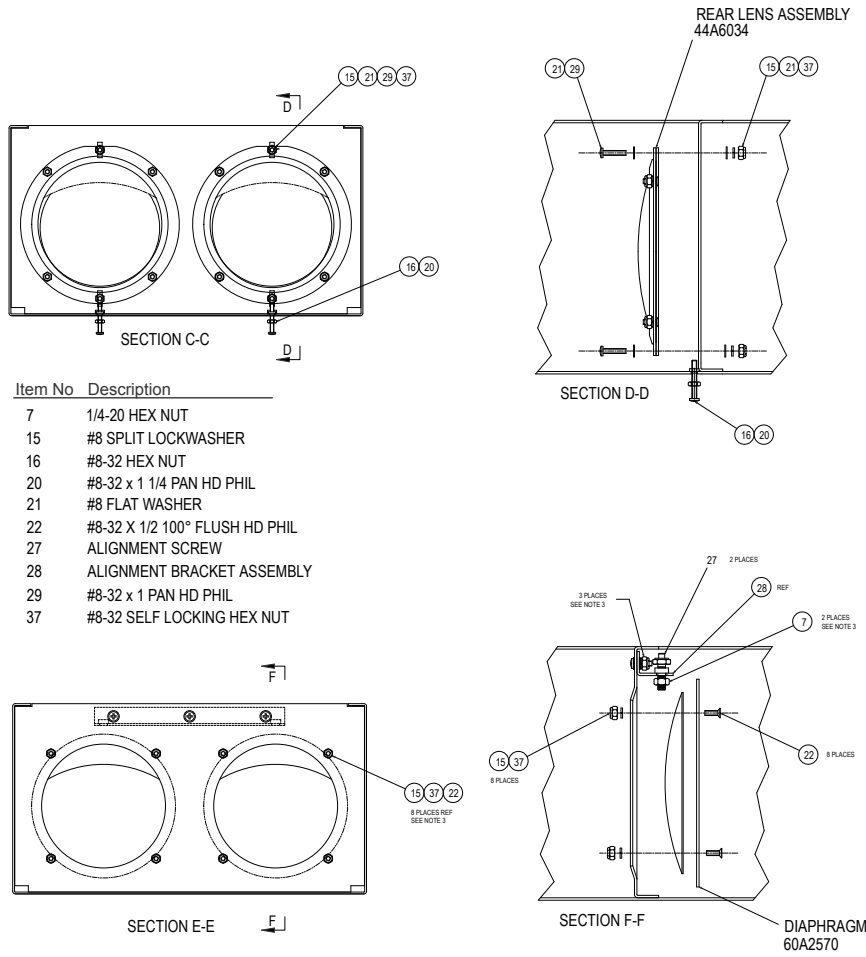

Figure 48: Optical Box Parts Detail C-C, E-E



Item No	Description
7	1/4-20 HEX NUT
15	#8 SPLIT LOCKWASHER
16	#8-32 HEX NUT
20	#8-32 x 1 1/4 PAN HD PHIL
21	#8 FLAT WASHER
22	#8-32 X 1/2 100° FLUSH HD PHIL
27	ALIGNMENT SCREW
28	ALIGNMENT BRACKET ASSEMBLY
29	#8-32 x 1 PAN HD PHIL
37	#8-32 SELF LOCKING HEX NUT

8.3 Optical Assembly Parts List

Table 14: Lamp Reflector Assembly Parts

Description	Part Number	Quantity	Note
Protective glass	63A0984	1	
Gasket for outer protective glass	63A1211	1	
Two-lamp lens	44A6034	2	A
Three-lamp lens		3	
Two-lamp filter	1438.12.220 Canada	2	A
Three-lamp filter	63A1019 FAA	3	
Two-lamp reflector	44A5996	2	A
Three-lamp reflector		3	

Notes

Table 14: Lamp Reflector Assembly Parts (Continued)

Description	Part Number	Quantity	Note
-------------	-------------	----------	------

^A Trained Qualified Personnel installation only.

Figure 49: Optical Box Side View

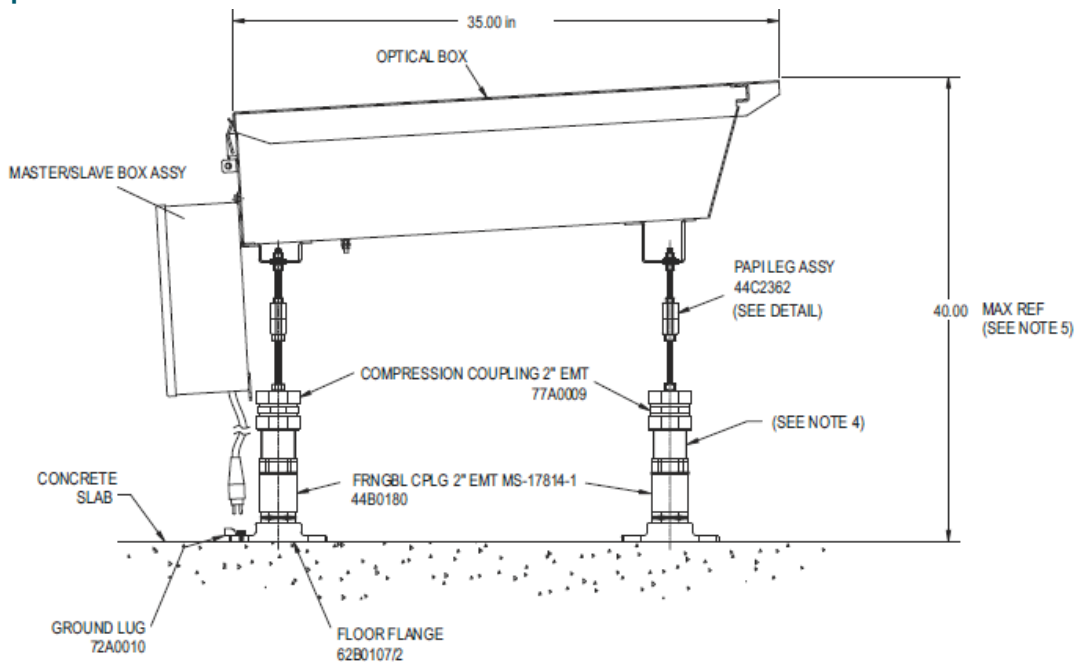

NOTES: from 44A4743:

#4: 2 inch EMT diameter (2 3/16 O.D.) Tube to be supplied and installed by contractor. Length to be determined at installation to adjust for uneven terrain and to mount light box at the correct elevation above runway. 2" EMT tube to extend 3 1/4 inches into item M1 and 1 1/2 inches into item M5 to insure straight installation. Tube must be painted int. orange FED. STD. 595A, Color# 12197 to reduce corrosion.

#5: See AC 150/5345-28 for exceptions

#7: Contractor to supply flexible conduit and couplings for cord sets to power supply and master/slave.

#8: See 43B1649 and 43B1650/2 for slave/master wiring.

#9: The nominal cord set length is 72 in. Since the length required for installation depends on the height of the PAPI unit and distance of the bottom of the unit from the wire entry point in the can or conduit, the customer should check the length required. If a longer or shorter cord set is required, the wires may be spliced (in accordance with local codes)

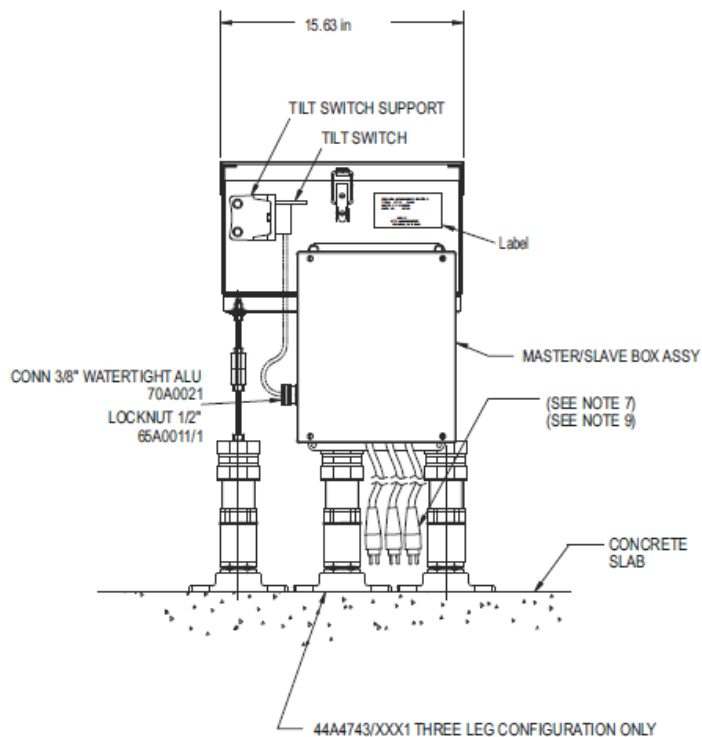

8.4 PAPI Style A Master Box Assembly Parts List

Item	Description	Part Number	Quantity	Note
Figure 51	Panel assembly	44D2656-XXX	1	
Figure 50	Male plug	73A0180	2	

NS: Not Shown

Figure 50: Master Box Assembly

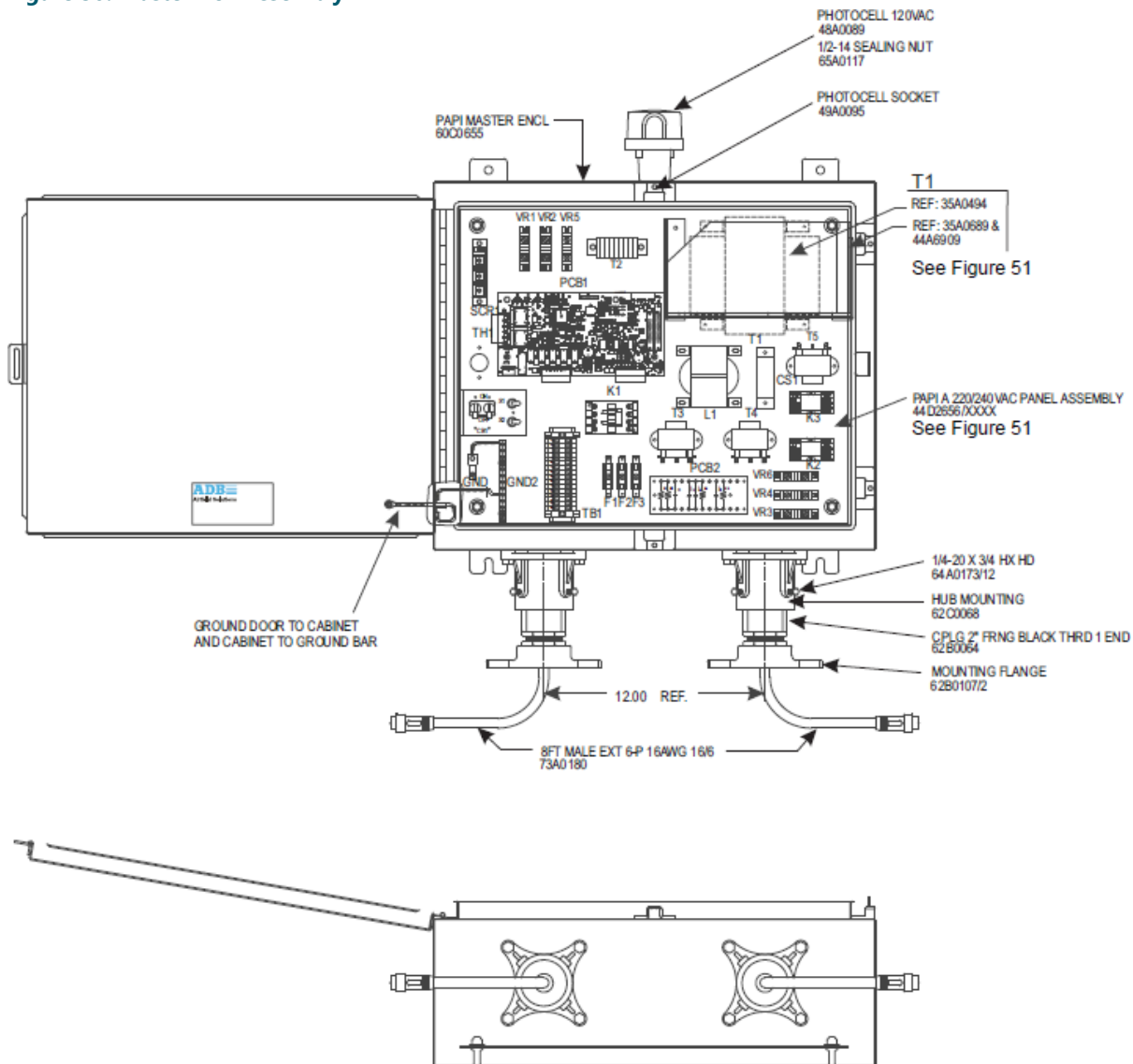

Table 15: PAPI Style A Master Panel Assembly Parts List

Item	Description	Part Number	Quantity	Note
TH1	Thermostat (Therm-O-Disc #37121)	54A0007	1	
PCB1	PAPI control PCB	44A6546-3	1	
SCR1	SCR	28A0011	1	
K3	Relay, 4PDT, 3 A, 24 Vdc coil	53A0310	1	

Table 15: PAPI Style A Master Panel Assembly Parts List (Continued)

Item	Description	Part Number	Quantity	Note
K2	Relay, 4PDT, 1A, 120 Vac coil	53A0284	1	
K2-3	Relay socket panel mounting	49A0155	2	
T2	Current XF, 6.6 A to .066 A	35A0548	1	
T3	Step down XF, 240 Vac to 120 Vac	35A0474	1	
T4	Step down XF, 240 to 18 Vac	35A0685	1	
T5	Step down XF, 240 to 18 Vac	35A0685	1	
K1	Contactor, 4P, 15 A, 120 Vac coil	53A0222	1	
CB1	Circuit breaker, 15 A, 2P	57A0039	1	
F1, F2	Fuse, 2 A, 250 V, Slo-Blo	47A0049	2	
F3	Fuse, 1/4 A, 250 V, Slo-Blo	47A0117	1	
F1-3	Fuse block	47A0061	3	
VR1, VR2	Lightning varistors, 571 Vac	32A0028	2	
VR3, VR4	Lightning varistors, 751 Vac	32A0025	2	
S1, S2	Toggle switch, SPST, 15 A, ON-OFF	45A0207	2	
PCB2	Snubber network PCB	44A4752	1	
CS1	Current sense switch	53A0283	1	
L1	Inductor	33A0013	1	
	Step-up transformer (used on L-880 only)			
T1	Two-lamp transformer	35A0689	1	A
	Three-lamp transformer	35A0494	1	
F4	Fuse 1A	47A0017	1	
F4	Fuse Block	47A0061	1	

See [Figure 51](#) .

Note

A: Replace T1 35A0457 with 35A0689 using Kit# 94A0548.
T1-35A0494 is for 4-Box, 3-LT. Units or 35A0689 for 4-Box, 2-LT. Units.
Master Box, 240 V, 4 Box, PAPI A only 44A4734-1210
Master Box, 240 V, 2 Box, PAPI A only 44A4734-2210

Figure 51: Master Panel Assemblies

44D2656-1X1X (4-BOX,3-LT. UNITS)
USING THE 35A0494 TX.

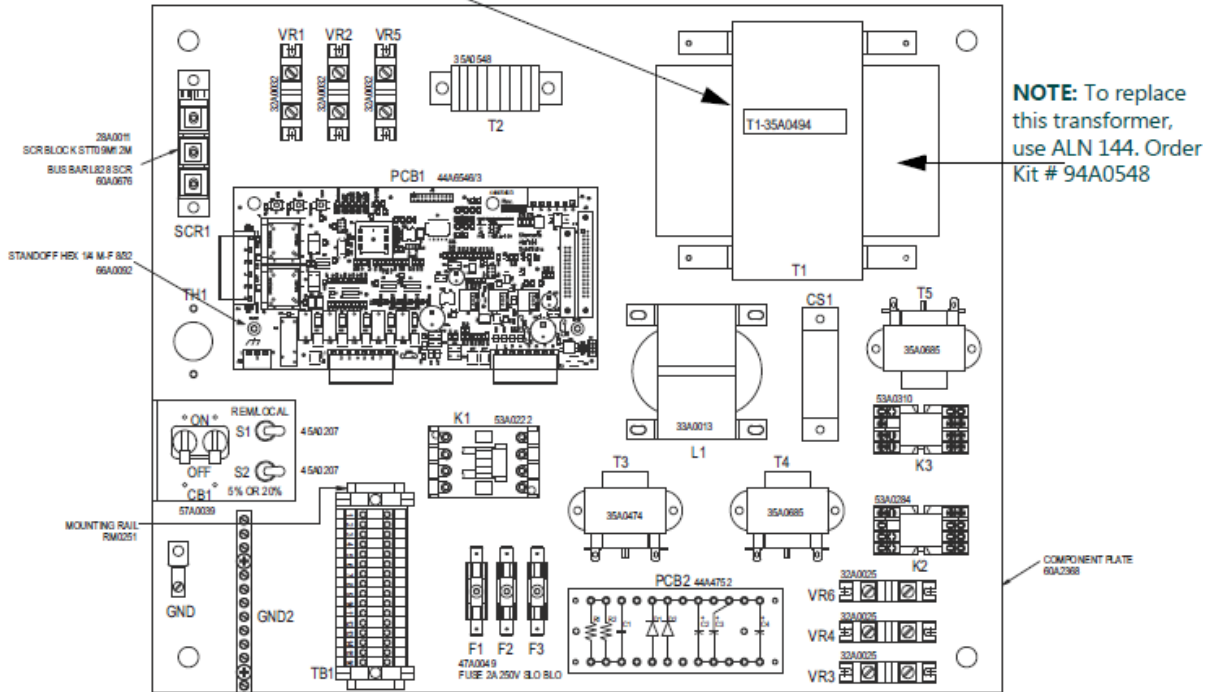

44D2656-1X2X (4-BOX,2-LT. UNITS)
USING THE 35A0689 TX.

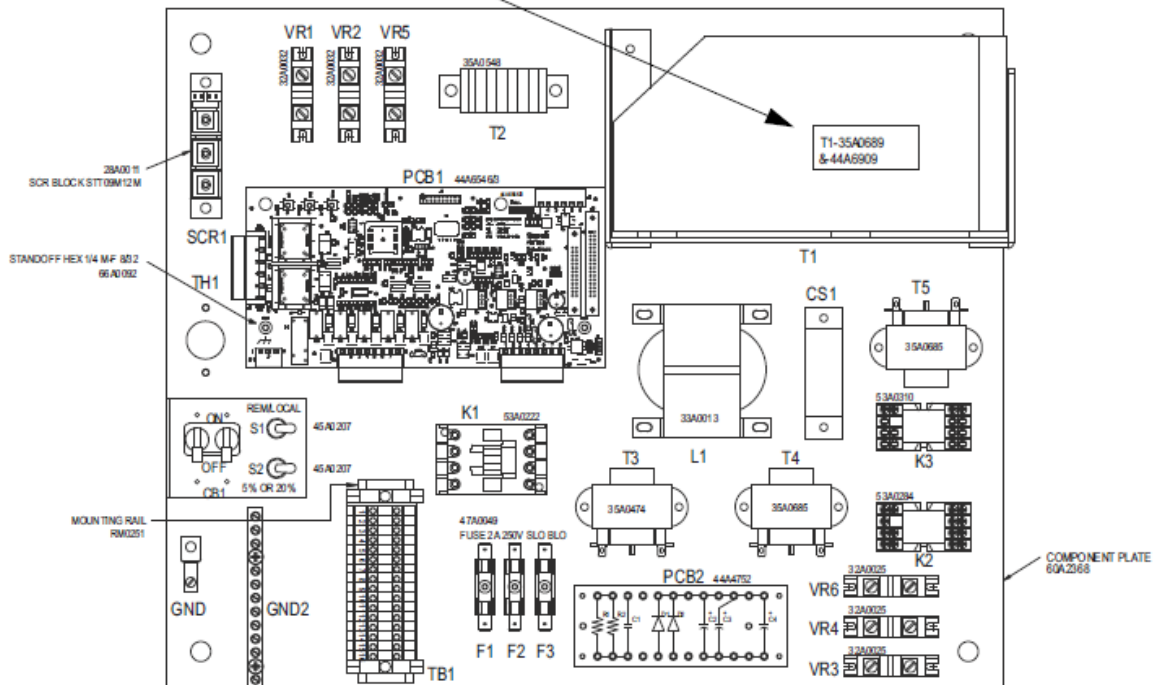

Table 16: L-880/L-881 PAPI Style A Optical Box Final Assembly Parts List

Item	Description	Part Number	Quantity	Note
1	Tilt switch assembly			
	Tilt switch assembly, Class I, -35 °C, without Heater	44A5863-2	1	
	Tilt switch assembly, Class II, -55 °C, with heater	44A5863-1	1	
2	Lamp, 200 W, 6.6 A	48A0077-1	See note.	A
3	Shorting device PCB	44D4538	1	B
4	Light box assembly			
	Light box assembly, two lights	60A2356	1	
	Light box assembly, three lights	60A2357	1	
5	Adjustable leg assembly	44C2362/SS	See note.	C
6	Frangible coupling assembly	44B0180	See note.	C
7	Coupling (Near TC616)	77A0009	See note.	C
8	Base flange	62B0107-2	See note.	C
9	Plug			
	Plug, two light	63B0371-21	2	
	Plug, three light	63B0371-23	2	

NOTE A: Two required for two-lamp assembly; three required for three-lamp assembly. Refer to *Replacing Lamp* in *Maintenance Procedures* in Section 5, *Maintenance*.

NOTE B: PCB is mounted vertically on inside back of light box for two-lamp box.

NOTE C: Three required for three-leg assembly; four required for four-leg assembly.

NS: Not Shown

8.5 PAPI Style A L-880 (4-Box) Field Splice Kit Parts List

This subsection provides parts for the L-880 PAPI A field splice kit with and without interlock option.

Table 17: PAPI Style A L-880 (4-Box) Field Splice Kit (With Interlock Option) Parts List

Item	Description	Part Number	Quantity	Note
NS	L-880 field splice kit (with interlock option)	94A0235-1	1	
NS	Frangible coupling	62A0711	4	
NS	6-pin female plug	73A0129	6	
NS	One-inch (25.4 mm) cable clamp	63A0563	4	
NS	Connector secondary kit plug	70A0050	1	
NS	Field splice heatshrink tube, 6 in. (152 mm) long	71A0053	15	
NS	Field butt splice for wire	71A0054	30	

NS: Not Shown

Table 18: PAPI Style A L-880 (4-Box) Field Splice Kit (Without Interlock Option) Parts List

Item	Description	Part Number	Quantity	Note
NS	L-880 field splice kit (without interlock option)	94A0235-3	1	
NS	Frangible coupling	62A0711	4	
NS	6-pin female plug	73A0129	6	
NS	One-inch (25.4 mm) cable clamp	63A0563	4	
NS	Field splice heatshrink tube, 6 in. (152 mm) long	71A0053	15	
NS	Field butt splice for wire	71A0054	30	

NS: Not Shown

8.6 PAPI Style A L-881 (2-Box) Field Splice Kit Parts List

This subsection provides parts for the L-881 PAPI A field splice kit with and without interlock option.

Table 19: PAPI Style A L-881 (2-Box) Field Splice Kit (With Interlock Option) Parts List

Item	Description	Part Number	Quantity	Note
NS	L-881 field splice kit (with interlock option)	94A0235-2	1	
NS	Frangible coupling	62A0711	4	
NS	6-pin female plug	73A0129	6	
NS	One-inch (25.4 mm) cable clamp	63A0563	4	
NS	Connector secondary kit plug	70A0050	1	
NS	Field splice heat shrink tube, 6 in. (152 mm) long	71A0053	15	
NS	Field butt splice for wire	71A0054	30	

NS: Not Shown

8.7 PAPI Style A L-881 (2-Box) Field Splice Kit (Without Interlock Option) Parts List

Item	Description	Part Number	Quantity	Note
NS	L-881 field splice kit (without interlock option)	94A0235-4		
NS	Frangible coupling	62A0711	4	
NS	6-pin female plug	73A0129	6	
NS	One-inch (25.4 mm) cable clamp	63A0563	4	
NS	Field splice heat shrink tube, 6 in. (152 mm) long	71A0053	15	
NS	Field butt splice for wire	71A0054	30	

NS: Not Shown

Table 20: PAPI Style A Aiming Device Kit Parts List

Item	Description	Part Number	Quantity	Note
NS	Aiming Device Kit	44A6031	See note.	A

NOTE A One per airport.
NS: Not Shown

8.8 Spare Parts

Table 21: PAPI A Spare Parts

Item	Description	Part Number	Quantity	Note
2	Lamp, 200 W, 6.6 A	48A0077-1	See note.	A, C
	Lamp driver/tilt sensing PCB (2 & 3 lamp)	44A5857		
	LC Control Board	44A6546-3		
1	Tilt switch assembly, Class I, -35 °C, without Heater	44A5863-2	1	C
1	Tilt switch assembly, Class II, -55 °C, with heater	44A5863-1	1	C
	PAPI-control PCB	44A6546-3	1	C
	Optical box, 2-lamp	44A5861-1	1	C
	Optical box, 3-lamp	44A5861-2	1	C
	Master box, 240 V, 4 box	44D4734-1210	1	D
	Master box, 240 V, 2 box	44D4734-2210	1	D
	Frangible coupling	44B0180	See note	B
	Frangible coupling 2" EMT	62A0711	See note	B
	Leg assembly	44C2362/SS	See note	B, E
	SCR Block	28A0011	1	D
NS	Shorting Device	44D4538	1	
NS	Spare Lamp Kit	94A0337	1	G
NS	Glass, protective (2 lamp PAPI) Glass, protective (3 lamp PAPI)	63A0984	1	
		63A0671-1	1	
NS	Gasket, 2 lamp optical assembly	63A1211	1	
	Gasket, 3 lamp optical assembly	63A1211	1	
NS	Red filter 6.61 inch length	1438.12.220	See note.	A
	Red filter 6.07 inch length (units sold after 2005)	63A1019		

NOTE A: Three required for three-lamp assembly; two required for two-lamp assembly. Refer to "Replacing Lamp" on page 62.

NOTE B: Three required for three-leg assembly; four required for four-leg assembly.

Note C: See [PAPI Style A Master Box Assembly Parts List](#).

Note D: See [Figure 50](#).

Note E: See [PAPI Style A Master Box Assembly Parts List](#).

Note F: For PAPI As ordered before Fall 2007, the LC Control Board may have part no. 44D1475/3. This part is now obsolete. To order a retrofit kit, use part no. 94A0549 for both L-880 and L-881. An L-880 unit also requires part no. 94A0548 to replace the T1 transformer.

Note G: For installations before May 2002. Spare Lamp Kit includes lamp and disconnects to convert power leads so lamp 48A0077-1 can be installed.

NS: Not Shown

Appendix A: SUPPORT

Our experienced engineers are available for support and service at all times, 24 hour/7 days a week. They are part of a dynamic organization making sure the entire ADB SAFEGATE is committed to minimal disturbance for airport operations.

ADB SAFEGATE Support

Live Technical Support - Americas

If at any time you have a question or concern about your product, just contact ADB SAFEGATE's technical service department. Trained in all areas of system issues, troubleshooting, quality control and technical assistance, our highly experienced Technical support specialists are available 24 hours a day, seven days a week to provide assistance over the phone.

ADB SAFEGATE **Americas Technical Service & Support (US & Canada): +1-800-545-4157**

ADB SAFEGATE Americas Technical Service & Support (International): +1-614-861-1304

During regular business hours, you can also Chat with a Service Technician. We look forward to working with you!

Before You Call

When you have an airfield lighting or system control system problem it is our goal to support airfield maintenance staff as quickly as possible. To support this effort we ask that you have the following information ready before calling.

- The *airport code*
- If not with an airport, then company name (prefer customer id number)
- Contact phone number and email address
- Product with part number preferable or product number
- Have you reviewed the product's manual and troubleshooting guide
- Do you have a *True RMS* meter available (and any other necessary tools)
- Be located with the product ready to troubleshoot

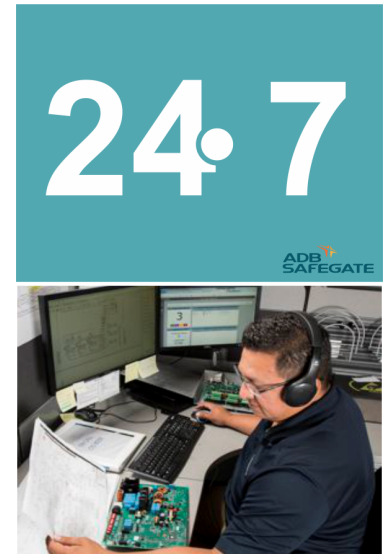

Note

For more information, see www.adbsafegate.com, or contact ADB SAFEGATE Support via email at support@adbsafegate.com or

Brussels: +32 2 722 17 11

Rest of Europe: +46 (0) 40 699 17 40

Americas: +1 614 861 1304. Press 3 for technical service or press 4 for sales support.

China: +86 (10) 8476 0106

A.1 ADB SAFEGATE Website

The ADB SAFEGATE website, www.adbsafegate.com, offers information regarding our airport solutions, products, company, news, links, downloads, references, contacts and more.

A.2 Recycling

A.2.1 Local Authority Recycling

The disposal of ADB SAFEGATE products is to be made at an applicable collection point for the recycling of electrical and electronic equipment. The correct disposal of equipment prevents any potential negative consequences for the environment and human health, which could otherwise be caused by inappropriate waste handling. The recycling of materials helps to conserve natural resources. For more detailed information about recycling of products, contact your local authority city office.

A.2.2 ADB SAFEGATE Recycling

ADB SAFEGATE is fully committed to environmentally-conscious manufacturing with strict monitoring of our own processes as well as supplier components and sub-contractor operations. ADB SAFEGATE offers a recycling program for our products to all customers worldwide, whether or not the products were sold within the EU.

ADB SAFEGATE products and/or specific electrical and electronic component parts which are fully removed/separated from any customer equipment and returned will be accepted for our recycling program.

All items returned must be clearly labeled as follows:

- For *ROHS/WEEE* Recycling
- Sender contact information (Name, Business Address, Phone number).
- Main Unit Serial Number.

ADB SAFEGATE will continue to monitor and update according for any future requirements for *EU directives* as and when *EU member states* implement new *regulations* and or *amendments*. It is our aim to maintain our *compliance plan* and assist our customers.

Company Addresses

ADB SAFEGATE, Belgium	ADB SAFEGATE BV Leuvensesteenweg 585, B-1930 Zaventem Belgium
Contact: Tel.: +32 2 722 17 11 Fax: +32 2 722 17 64	Email: marketing@adbsafegate.com Internet: www.adbsafegate.com
ADB SAFEGATE, Americas	ADB SAFEGATE Americas LLC 977 Gahanna Parkway, Columbus, OH 43230 USA
Contact: Tel.: +1 (614) 861 1304 Fax: +1 (614) 864 2069	Email: sales.us@adbsafegate.com Internet: www.adbsafegate.com
ADB SAFEGATE, Sweden	ADB SAFEGATE Sweden AB Djurhagegatan 19 SE-213 76 Malmö Sweden
Contact: Tel.: +46 (0)40 699 17 00 Fax: +46 (0)40 699 17 30	Email: marketing@adbsafegate.com Internet: www.adbsafegate.com
ADB SAFEGATE, China	ADB SAFEGATE Airfield Technologies Ltd. China Unit 603, D Block, CAMIC International Convention Center, No 3, Hua Jia Di East road, ChaoYang district, Beijing 100102 P.R. China
Contact: Tel.: +86 (10) 8476 0106 Fax: +86 (10) 8476 0090	Email: china@safegate.com Internet: www.adbsafegate.com
ADB SAFEGATE, Germany	ADB SAFEGATE Germany GmbH Konrad-Zuse-Ring 6, D-68163 Mannheim Germany
Contact: Tel.: +49 (621) 87 55 76-0 Fax: +49 (621) 87 55 76-55	Email: marketing@adbsafegate.com Internet: www.adbsafegate.com



Powering Your Airport Performance from Approach to Departure

adbsafegate.com

Copyright © ADB SAFEGATE, all rights reserved

