



Constant Current Regulator

Type CRE

User Manual

UM-6008, Rev. 2.9.0, 2026-02-20

**ADB
SAFEGATE**

A.0 Disclaimer / Standard Warranty

CE certification

The equipment listed as CE certified means that the product complies with the essential requirements concerning safety and hygiene. The European directives that have been taken into consideration in the design are available on written request to ADB SAFEGATE.

ETL certification

The equipment listed as ETL certified means that the product complies with the essential requirements concerning safety and C22.2 No.180:13 (R2018) regulations. The CSA directives that have been taken into consideration in the design are available on written request to ADB SAFEGATE.

All Products Guarantee

ADB SAFEGATE will correct by repair or replacement per the applicable guarantee below, at its option, equipment or parts which fail because of mechanical, electrical or physical defects, provided that the goods have been properly handled and stored prior to installation, properly installed and properly operated after installation, and provided further that Buyer gives ADB SAFEGATE written notice of such defects after delivery of the goods to Buyer. Refer to the Safety section for more information on Material Handling Precautions and Storage precautions that must be followed.

ADB SAFEGATE reserves the right to examine goods upon which a claim is made. Said goods must be presented in the same condition as when the defect therein was discovered. ADB SAFEGATE further reserves the right to require the return of such goods to establish any claim.

ADB SAFEGATE's obligation under this guarantee is limited to making repair or replacement within a reasonable time after receipt of such written notice and does not include any other costs such as the cost of removal of defective part, installation of repaired product, labor or consequential damages of any kind, the exclusive remedy being to require such new parts to be furnished.

ADB SAFEGATE's liability under no circumstances will exceed the contract price of goods claimed to be defective. Any returns under this guarantee are to be on a transportation charges prepaid basis. For products not manufactured by, but sold by ADB SAFEGATE, warranty is limited to that extended by the original manufacturer. This is ADB SAFEGATE's sole guarantee and warranty with respect to the goods; there are no express warranties or warranties of fitness for any particular purpose or any implied warranties of fitness for any particular purpose or any implied warranties other than those made expressly herein. All such warranties being expressly disclaimed.

Standard Products Guarantee

Products manufactured by ADB SAFEGATE are guaranteed against mechanical, electrical, and physical defects (excluding lamps) which may occur during proper and normal use for a period of two years from the date of ex-works delivery, and are guaranteed to be merchantable and fit for the ordinary purposes for which such products are made.



Note

See your applicable sales agreement for a complete warranty description.

Replaced or repaired equipment under warranty falls into the warranty of the original delivery. No new warranty period is started for these replaced or repaired products.

FAA Certified products manufactured by ADB SAFEGATE

ADB SAFEGATE L858 Airfield Guidance Signs are warranted against mechanical and physical defects in design or manufacture for a period of 2 years from date of installation, per FAA AC 150/5345-44 (applicable edition).

ADB SAFEGATE LED products (with the exception of obstruction lighting) are warranted against electrical defects in design or manufacture of the LED or LED specific circuitry for a period of 4 years from date of installation, per FAA EB67 (applicable edition). These FAA certified constant current (series) powered LED products must be installed, interfaced and powered with and through products certified under the FAA Airfield Lighting Equipment Program (ALECP) to be included in this 4 (four) year warranty. This includes, but is not limited to, interface with products such as Base Cans, Isolation Transformers, Connectors, Wiring, and Constant Current Regulators.



Note

See your sales order contract for a complete warranty description.

Replaced or repaired equipment under warranty falls into the warranty of the original delivery. No new warranty period is started for these replaced or repaired products.

Liability



WARNING

Use of the equipment in ways other than described in the catalog leaflet and the manual may result in personal injury, death, or property and equipment damage. Use this equipment only as described in the manual.

ADB SAFEGATE cannot be held responsible for injuries or damages resulting from non-standard, unintended uses of its equipment. The equipment is designed and intended only for the purpose described in the manual. Uses not described in the manual are considered unintended uses and may result in serious personal injury, death or property damage.

Unintended uses, includes the following actions:

- Making changes to equipment that have not been recommended or described in this manual or using parts that are not genuine ADB SAFEGATE replacement parts or accessories.
- Failing to make sure that auxiliary equipment complies with approval agency requirements, local codes, and all applicable safety standards if not in contradiction with the general rules.
- Using materials or auxiliary equipment that are inappropriate or incompatible with your ADB SAFEGATE equipment.
- Allowing unskilled personnel to perform any task on or with the equipment.

Copyright Statement

This manual or parts thereof may not be reproduced, stored in a retrieval system, or transmitted, in any form or by any means, electronic, mechanical, photocopying, recording, nor otherwise, without the author's prior written consent.

This manual could contain technical inaccuracies or typographical errors. The author reserves the right to revise this manual from time to time in the contents thereof without obligation of the author to notify any person of such revision or change. Details and values given in this manual are average values and have been compiled with care. They are not binding, however, and the author disclaims any liability for damages or detriments suffered as a result of reliance on the information given herein or the use of products, processes or equipment to which this manual refers. No warranty is made that the use of the information or of the products, processes or equipment to which this manual refers will not infringe any third party's patents or rights. The information given does not release the buyer from making their own experiments and tests.

Table of Contents

1.0 Safety	1
1.1 Safety Messages.....	1
1.1.1 Introduction to Safety.....	2
1.1.2 Intended Use.....	2
1.1.3 Material Handling Precautions: Storage.....	3
1.1.4 Material Handling Precautions, ESD.....	3
1.1.5 Operation Safety.....	4
1.1.6 Maintenance Safety.....	4
1.1.7 Touch Current.....	4
2.0 Description	5
2.1 Intended Use.....	5
2.2 Working Principle.....	5
2.3 Layout of the Equipment Cabinet	6
2.3.1 Outside - stackable cabinet 2.5 kVA	7
2.3.2 Inside - stackable cabinet 2.5 kVa	8
2.3.3 Outside - small cabinet: 2.5 to 15 kVA.....	9
2.3.4 Inside - small cabinet: 2.5 to 15 kVA.....	9
2.3.5 Outside - small cabinet: 2.5 to 15 kVA with CS (option CS)	11
2.3.6 Inside - small cabinet: 2.5 to 15 kVA with CS (option CS).....	11
2.3.7 Outside - big cabinet 20 to 30 kVA.....	12
2.3.8 Inside - big cabinet 20 to 30 kVa	13
2.3.9 Outside - big cabinet: 20 to 30 kVA with CS (option CS)	14
2.3.10 Inside - big cabinet: 20 to 30 kVA with CS (option CS).....	14
2.4 Components.....	15
2.4.1 Line input.....	15
2.4.2 Input filter.....	17
2.4.3 IGBT power bridge	18
2.4.4 Hall sensor, big cabinet	20
2.4.5 Output filter	20
2.4.6 Main transformer, all cabinets	21
2.4.7 Output measure PCB (EPS422), all cabinets.....	21
2.4.8 Power output	21
2.4.9 CPU PCB (EPS479), all cabinets.....	22
2.4.10 Remote control PCB (EPS495 or EP00047), all cabinets	22
2.4.11 Power supply PCB (EPS480), all cabinets	23
2.4.12 Lamp Fault Detection (LFD)	23
2.4.13 Earth Fault Detection (EFD).....	23
2.5 Options.....	24
2.5.1 Remote control.....	24
2.5.2 Ethernet PCB (EPS542), all cabinets.....	24
2.5.3 Multiwire PCB (EP00051), all cabinets	24
2.5.4 Circuit selector (CS)	24
2.5.5 Lightning arrestors (option CS)	25
2.5.6 Interface PCB (PCB1702) (option CS).....	25
2.5.7 CS PCB (PCB1619) (option CS)	25
2.5.8 HMI SIN PCB (PCB1703) (option CS).....	26
2.5.9 Remote control SIN PCB (PCB1694) (option CS)	26
2.5.10 CS relay (option CS).....	27
2.5.11 Current sensor (option CS)	27
2.5.12 Series Connector Box (SCB), all cabinets	28
2.5.13 Series CutOut (SCO), all cabinets	28
2.5.14 Rolling castors	28
2.6 HMI.....	28
2.7 HMI of an equipment with CS (option CS).....	29
2.8 Nameplate	29
3.0 Description of the HMI	31
3.1 HMI overview for an equipment with a CS (option CS)	31
3.2 Display overview: Main screen.....	32

3.3 Description of general functions	33
3.4 Main menu.....	33
3.5 Options menu	34
3.6 Alarms menu	34
3.7 Maintenance menu	34
3.8 Mode menu	35
3.9 How to enter an alphanumeric string.....	35
3.10 Alarm texts and messages on the HMI.....	36
4.0 Description of the configuration software tool	39
4.1 Description of screens and menus	39
4.1.1 Screens	40
4.2 CCR status screen	40
4.2.1 CCR Status	41
4.2.2 EFD Errors.....	41
4.2.3 LFD Errors.....	41
4.2.4 Regulation Errors.....	42
4.2.5 CCR Errors	42
4.2.6 Mains Voltage Errors.....	43
4.2.7 Output.....	43
4.3 Output/Mains screen	43
4.3.1 Output currents.....	44
4.3.2 Off if overload.....	44
4.3.3 Overcurrent.....	44
4.3.4 Step Parameters.....	45
4.3.5 Mains.....	45
4.4 Test screen.....	45
4.4.1 Brightness	46
4.4.2 Ctrl Hardware Iprim	46
4.4.3 Test JBUS.....	46
4.5 Configuration screen.....	46
4.5.1 CCR ID	47
4.5.2 Change Slave Number	47
4.5.3 SN/YearCode.....	47
4.5.4 Maintenance Password	47
4.6 EFD/LFD screen	48
4.6.1 EFD Enable	48
4.6.2 EFD Levels.....	48
4.6.3 LFD Inh.....	49
4.6.4 LFD Levels.....	49
4.6.5 VA Drop + delay	49
4.7 Diag/Dsp/BUS screen	49
4.7.1 Slave Errors	50
4.7.2 Rem Reset	51
4.7.3 Dsp Parameters.....	51
4.7.4 Imp Test.....	51
4.7.5 Hours_Meter	51
4.7.6 Rem Reset	52
4.7.7 Speed	52
4.8 Copy Parameters screen.....	52
4.8.1 Load parameters from CCR	52
4.9 Log screen.....	53
4.10 Test JBus screen	53
5.0 Circuit selector web interface (option CS)	55
6.0 Install and operate the configuration software tool.....	57
6.1 Install the configuration tool software	57
6.2 Start the configuration software tool	57
6.3 Monitor the data of an equipment	59
6.4 Stop the configuration software tool.....	59
7.0 Commissioning.....	61
7.1 First start-up	61

7.1.1 Procedure.....	61
7.1.2 Measure input voltage.....	61
7.1.3 Measure input voltage on stackable cabinet	62
7.1.4 Measure output current in short-circuit	63
7.1.5 Put SCB in short-circuit.....	63
7.1.6 Put SCO in short circuit	64
7.1.7 Measure the output current in short circuit	64
7.1.8 Test CS in short-circuit (option CS)	65
7.1.9 Measure output current series circuit (option CS)	67
7.1.10 Measure resistance and the insulation resistance of series circuit.....	68
7.1.11 Prepare with SCB	68
7.1.12 Prepare with SCO	69
7.1.13 Measure resistance of series circuit.....	69
7.1.14 Measure insulation resistance of series circuit	70
7.1.15 Calculate minimum insulation resistance of series circuit	70
7.1.16 Calculate resistance of series circuit	70
7.1.17 Complete the measurement	70
7.1.18 Measure the output current to the series circuit.....	71
7.2 Calibrate Lamp Fault Detection (LFD).....	71
7.3 Remote control configuration: multiwire (option)	73
7.4 Remote control configuration: J-Bus (option)	73
7.5 Remote control configuration: ethernet (option).....	73
7.6 CS configuration (option CS)	74
8.0 Operation.....	77
8.1 Switch ON the equipment	77
8.2 Switch OFF the equipment	77
8.3 Switch OFF the power supply.....	77
8.4 Switch between local and remote mode.....	78
8.5 Select brightness step	78
8.6 Adjust number of used brightness steps	78
8.7 Alarms	78
8.8 Use Series CutOut (SCO).....	79
8.8.1 Operation mode	79
8.8.2 Adjust operation mode	80
8.9 Operation mode.....	80
9.0 Troubleshooting.....	83
9.1 Preliminary checks.....	83
9.2 Troubleshooting guide.....	83
9.2.1 Fault: Equipment does not turn ON	83
9.2.2 Fault: Equipment does not go to the ON state	84
9.2.3 Fault: Equipment turns ON but suddenly de-energizes	85
9.2.4 Fault: equipment does not produce requested output current.....	85
9.3 Checks and measurements.....	85
9.3.1 Measure input voltage.....	86
9.3.2 Measure output current.....	86
9.3.3 Check fuse breaker and voltage of switch board	86
9.3.4 Calculate minimum insulation resistance of series circuit.....	86
9.3.5 Calculate resistance of series circuit	86
9.3.6 Measure cable capacitance	87
10.0 Maintenance.....	89
10.1 Preventive maintenance schedule	89
10.2 Part replacement	89
10.2.1 Required tools	90
10.2.2 CPU PCB (EPS479) replacement.....	91
10.2.3 CS PCB (PCB1619) replacement (option CS).....	91
10.2.4 CS Relay replacement (option CS).....	92
10.2.5 Diode bridge + sensing PCB (EPS476 / EPS507) replacement, small and stackable cabinet.....	93
10.2.6 Diode bridge and sensing PCB (EPS476) replacement, big cabinet	94
10.2.7 Display and keyboard replacement	96
10.2.8 Fuses on the power supply PCB (EPS480) replacement.....	96

10.2.9 HMI SIN PCB (PCB1694) replacement (option CS).....	97
10.2.10 IGBT replacement, stackable and small cabinet	97
10.2.11 IGBT replacement, big cabinet.....	99
10.2.12 IGBT PCB (EPS477 / EPS 478) replacement, small cabinet.....	100
10.2.13 IGBT PCB (EPS496) replacement, big cabinet	102
10.2.14 Input filter replacement, stackable cabinet	103
10.2.15 Input filter replacement, small (up to 10 kVA) cabinet.....	104
10.2.16 Input filter replacement, small cabinet (15 kVA) and big cabinet.....	105
10.2.17 Interface PCB (PCB1702) replacement (option CS)	106
10.2.18 Lightning arrestors replacement, equipment with SCO or SCB.....	106
10.2.19 Line filter replacement.....	107
10.2.20 Main contactor replacement, small cabinet	107
10.2.21 Main contactor replacement, big cabinet	108
10.2.22 Main fuses replacement	109
10.2.23 Manual switch replacement	110
10.2.24 Output filter replacement, stackable cabinet.....	111
10.2.25 Output filter replacement, small (up to 10 kVA) cabinet.....	111
10.2.26 Output filter replacement, small cabinet 15 kVA and big cabinet.....	112
10.2.27 Output measure PCB (EPS442) replacement.....	113
10.2.28 Power supply PCB (EPS480) replacement	114
10.2.29 Remote control PCB (EPS495 or EP00051) replacement.....	115
10.2.30 Series CutOut (SCO) replacement (option).....	115
10.2.31 Series Connection Box (SCB) replacement (option).....	117
10.3 Remove panels.....	118
10.3.1 Generic panels.....	119
10.3.2 Remove the display / keyboard panel of the small cabinet.....	120
10.3.3 Remove the display / keyboard panel of the big cabinet.....	121
10.3.4 Remove the display / keyboard panel of a cabinet with a CS (option CS).....	121
10.3.5 Top panel (small cabinet).....	122
10.4 Firmware update	123
10.4.1 Install the software to upload the firmware	124
10.4.2 Change the SD Flash file paths.....	124
10.4.3 Check equipment parameters	125
10.4.4 Update the firmware	125
10.4.5 Start the equipment after a firmware update	126
11.0 PCB drawings and settings	127
11.1 CPU PCB (EPS479).....	127
11.1.1 LEDs	127
11.2 Power supply PCB (EPS480)	128
11.2.1 LEDs	128
11.2.2 Fuses	128
11.3 Remote Control PCB.....	129
11.3.1 EPS495 (1597.00.300)	129
11.3.1.1 LEDs.....	129
11.3.1.2 Jumper settings.....	129
11.3.2 EP00047 and EP00051	131
11.3.3 Multiwire/J-Bus Connection Scheme.....	131
11.4 IGBT PCB (EPS477 / EPS 496)	135
11.4.1 LEDs EPS477 for 2s Semix.....	135
11.4.2 Printed Circuit Board (PCB) EPS496 for 3s Semix.....	136
11.4.3 LEDs EPS477 for 1s and 2s Semix.....	136
11.5 Output measure PCB (EPS442).....	137
11.5.1 LEDs	137
11.6 Diode bridge and sensing PCB (EPS476 / EPS 507).....	137
11.6.1 LEDs	137
11.7 Interface PCB (PCB1702) (option CS)	138
11.7.1 Jumper J2	138
11.7.2 Connectors.....	138
11.7.3 LEDs	140
11.8 CS PCB (PCB1619) (option CS).....	141
11.8.1 Connectors.....	142

11.8.2 LEDs	142
11.8.3 Dip switch	142
11.9 HMI SIN PCB (PCB1703) (option CS)	143
11.9.1 Connectors	143
11.9.2 LEDs	143
11.10 Test parameters	144
11.10.1 Analog channels	144
11.10.2 Input	145
11.10.3 Output	145
11.10.4 External input	145
11.10.5 External output	145
11.10.6 PIC analog channels	145
12.0 Wiring Diagram	147
13.0 Technical Data	149
13.1 Applicable standards	150
13.2 ElectroMagnetic Compatibility (EMC)	150
13.3 Dimensions and mass	151
13.4 Protection devices	152
13.5 Used brightness steps	152
13.6 Ambient conditions	153
13.7 Parts list	153
13.7.1 Preventive spare parts	153
13.7.2 Corrective spare parts	159
A.0 Support	163
A.1 ADB SAFEGATE Website	164
A.2 Recycling	165
A.2.1 ADB SAFEGATE Recycling	165
A.2.1.1 Local Authority Recycling	165

List of Figures

Figure 1: Series circuit system overview	5
Figure 2: Input terminal, all cabinets	15
Figure 3: Line filter, all cabinets.....	15
Figure 4: Manual switch, all cabinets.....	15
Figure 5: Main fuses, all cabinets	16
Figure 6: Main contactor, stackable cabinet and small cabinet.....	16
Figure 7: Main contactor, big cabinet	16
Figure 8: Sensing transformer, all cabinets	16
Figure 9: Power supply transformer, all cabinets	17
Figure 10: Input filter, stackable cabinet and small cabinet (except 15 kVA).....	17
Figure 11: Input filter, 15 kVA small cabinet and big cabinet	17
Figure 12: Diode bridge + sensing PCB (EPS476 /EPS507), stackable cabinet and small cabinet	18
Figure 13: Sensing PCB (EPS476), big cabinet.....	18
Figure 14: Diode bridge, big cabinet.....	19
Figure 15: IGBT, all cabinets	19
Figure 16: IGBT PCB (EPS477 /EPS496 /EPS 478), all cabinets.....	19
Figure 17: Output filter, stackable cabinets and small cabinet (except 15 kVA).....	20
Figure 18: Output filter, 15 kVA small cabinet and big cabinet.....	20
Figure 19: HMI overview	31
Figure 20: General	39
Figure 21: Description of settings	55
Figure 22: Select a 'useable IP address'.....	74
Figure 23: CS PCB.....	92
Figure 24: Printed Circuit Board (PCB).....	127
Figure 25: Printed Circuit Board (PCB).....	128
Figure 26: Printed Circuit Board (PCB).....	129
Figure 27: Printed Circuit Board (PCB).....	131
Figure 28: Multiwire/J-Bus Pin Numbering.....	131
Figure 29: Multiwire and J-Bus Connection.....	134
Figure 30: Printed Circuit Board (PCB) EPS477 for 2s Semix	135
Figure 31: Printed Circuit Board (PCB).....	137
Figure 32: Printed Circuit Board (PCB).....	137
Figure 33: Printed Circuit Board (PCB).....	138
Figure 34: Printed Circuit Board (PCB).....	141
Figure 35: Printed Circuit Board (PCB).....	143
Figure 36: CRE Wiring Diagram.....	147
Figure 37: The stackable cabinet (A), the small cabinet (B) and the big cabinet (C).....	151

List of Tables

Table 1: Display description: Main screen	32
Table 2: General function buttons	33
Table 3: Display description: Menu screen	33
Table 4: Buttons.....	34
Table 5: Buttons.....	34
Table 6: General function buttons	35
Table 7: General function buttons	35
Table 8: Configuration settings.....	55
Table 9: Series circuits data	55
Table 10: Theoretical insulation resistance for the series circuit	70

Table 11: Equipment does not turn ON	83
Table 12: Equipment does not turn ON	84
Table 13: Equipment turns ON but suddenly de-energizes	85
Table 14: Equipment does not produce the requested output current.....	85
Table 15: Preventive maintenance schedule	89
Table 16: CPU PCB LED functions.....	127
Table 17: Power supply PCB LED functions	128
Table 18: Power supply PCB Fuses	128
Table 19: Remote control PCB LED functions.....	129
Table 20: Remote control PCB jumper settings	129
Table 21: Factory set terminal assignments for remote control connections with multiwire and single J-Bus (Cable Set 4072.30.XXX).....	132
Table 22: Factory set terminal assignments for remote control connections with multiwire dual J-Bus (Cable Set 4072.30.182).....	133
Table 23: IGBT PCB LED functions.....	135
Table 24: IGBT PCB LED functions.....	136
Table 25: Phase bridge PCB LED RUN light functions	137
Table 26: LEDs - Diode bridge and sensing PCB LED functions	138
Table 27: 12CS connectors	138
Table 28: LEDs that indicate the logic functionality.....	140
Table 29: LEDs that indicate the interface functionality	141
Table 30: CS connectors	142
Table 31: Dip switch SW1	142
Table 32: Analog channels.....	144
Table 33: Test input parameters	145
Table 34: Test output parameters.....	145
Table 35: PIC analog channels test	145
Table 36: Technical Specifications.....	149
Table 37: Output specifications.....	149
Table 38: Supply earthing systems and system voltage (V).....	150
Table 39: Prospective short-circuit current (PSCC) and residual current device (RCD).....	150
Table 40: Dimensions.....	151
Table 41: Mass	151
Table 42: Protection devices specifications	152
Table 43: Current values produced at each brightness step	152
Table 44: Ambient conditions	153
Table 45: Preventive spare parts - Main fuse	154
Table 46: Preventive spare parts - Main contactor.....	154
Table 47: Preventive spare parts - Lightning arrestors.....	155
Table 48: Preventive spare parts - Overvoltage protection.....	155
Table 49: Preventive spare parts - Capacitors.....	155
Table 50: Preventive spare parts - Safety switches	155
Table 51: Preventive spare parts - Fans	155
Table 52: Preventive spare parts - CPU PCB and CPU PCB with OVP	156
Table 53: Preventive spare parts - IGBT bridge.....	156
Table 54: Preventive spare parts - Output measure PCB	156
Table 55: Preventive spare parts - Power supply PCB	157
Table 56: Preventive spare parts - Remote control PCB.....	157
Table 57: Preventive spare parts - Diode bridge PCB and diode bridge PCB with OVP	158
Table 58: Preventive spare parts - IGBT PCB.....	158
Table 59: Preventive spare parts - Ethernet adapter	159
Table 60: Preventive spare parts - Display and keyboard	159

Table 61: Corrective spare parts - Manual switch.....	159
Table 62: Corrective spare parts - Main fuse housing.....	160
Table 63: Corrective spare parts - Line filter	160
Table 64: Corrective spare parts - Input filter	160
Table 65: Corrective spare parts - Output filter	161
Table 66: Corrective spare parts - Main transformer	161
Table 67: Corrective spare parts - Hall sensor	162
Table 68: Corrective spare parts - CS parts	162

1.0 Safety

Introduction to Safety







This section contains general safety instructions for installing and using ADB SAFEGATE equipment. Some safety instructions may not apply to the equipment in this manual. Task- and equipment-specific warnings are included in other sections of this manual where appropriate.

1.1 Safety Messages

HAZARD Icons used in this manual

For all HAZARD symbols in use, see the Safety section. All symbols must comply with ISO and ANSI standards.

Carefully read and observe all safety instructions in this manual, which alert you to safety hazards and conditions that may result in personal injury, death or property and equipment damage and are accompanied by the symbols shown below.

	<p>WARNING</p> <p>Failure to observe a warning may result in personal injury, death or equipment damage.</p>
	<p>DANGER – Risk of electrical shock or ARC FLASH</p> <p>Disconnect equipment from line voltage. Failure to observe this warning may result in personal injury, death, or equipment damage. ARC Flash may cause blindness, severe burns or death.</p>
	<p>WARNING – Wear personal protective equipment</p> <p>Failure to observe may result in serious injury.</p>
	<p>WARNING – Do not touch</p> <p>Failure to observe this warning may result in personal injury, death, or equipment damage.</p>
	<p>CAUTION</p> <p>Failure to observe a caution may result in equipment damage.</p>
	<p>ELECTROSTATIC SENSITIVE DEVICES</p> <p>This equipment may contain electrostatic devices.</p>

Qualified Personnel

	<p>Important Information</p> <p>The term qualified personnel is defined here as individuals who thoroughly understand the equipment and its safe operation, maintenance and repair. Qualified personnel are physically capable of performing the required tasks, familiar with all relevant safety rules and regulations and have been trained to safely install, operate, maintain and repair the equipment. It is the responsibility of the company operating this equipment to ensure that its personnel meet these requirements.</p> <p>Always use required personal protective equipment (PPE) and follow safe electrical work practice.</p>
---	---

1.1.1 Introduction to Safety



CAUTION

Unsafe Equipment Use

This equipment may contain electrostatic devices, hazardous voltages and sharp edges on components

- Read installation instructions in their entirety before starting installation.
- Become familiar with the general safety instructions in this section of the manual before installing, operating, maintaining or repairing this equipment.
- Read and carefully follow the instructions throughout this manual for performing specific tasks and working with specific equipment.
- Make this manual available to personnel installing, operating, maintaining or repairing this equipment.
- Follow all applicable safety procedures required by your company, industry standards and government or other regulatory agencies.
- Install all electrical connections to local code.
- Use only electrical wire of sufficient gauge and insulation to handle the rated current demand. All wiring must meet local codes.
- Route electrical wiring along a protected path. Make sure they will not be damaged by moving equipment.
- Protect components from damage, wear, and harsh environment conditions.
- Allow ample room for maintenance, panel accessibility, and cover removal.
- Protect equipment with safety devices as specified by applicable safety regulations
- If safety devices must be removed for installation, install them immediately after the work is completed and check them for proper functioning prior to returning power to the circuit.

Failure to follow these instructions can result in serious injury, death or equipment damage

Additional Reference Materials



Important Information

- IEC – International Standards and Conformity Assessment for all electrical, electronic and related technologies.
- IEC 60364 – Electrical Installations in Buildings.
- CSA – C22.2 No.180:13 (R2018), series isolating transformers for airport lighting.
- FAA Advisory: AC 150/5340-26 (current edition), Maintenance of Airport Visual Aid Facilities.
- Maintenance personnel must refer to the maintenance procedure described in the ICAO Airport Services Manual, Part 9.
- ANSI/NFPA 79, Electrical Standards for Metalworking Machine Tools.
- National and local electrical codes and standards.

1.1.2 Intended Use



CAUTION

Use this equipment as intended by the manufacturer

This equipment is designed to perform a specific function, do not use this equipment for other purposes

- Using this equipment in ways other than described in this manual may result in personal injury, death or property and equipment damage. Use this equipment only as described in this manual.

Failure to follow this instruction can result in serious injury or equipment damage

1.1.3 Material Handling Precautions: Storage



CAUTION

Improper Storage

Store this equipment properly

- If equipment is to be stored prior to installation, it must be protected from the weather elements and kept free of condensation and dust.

Failure to follow this instruction can result in equipment damage

1.1.4 Material Handling Precautions, ESD



CAUTION

Electrostatic Sensitive Devices

This equipment may contain electrostatic devices

- Protect from electrostatic discharge.
- Electronic modules and components should be touched only when this is unavoidable e.g. soldering, replacement.
- Before touching any component of the cabinet you shall bring your body to the same potential as the cabinet by touching a conductive earthed part of the cabinet.
- Electronic modules or components must not be brought in contact with highly insulating materials such as plastic sheets, synthetic fiber clothing. They must be laid down on conductive surfaces.
- The tip of the soldering iron must be grounded.
- Electronic modules and components must be stored and transported in conductive packing.

Failure to follow this instruction can result in equipment damage

1.1.5 Operation Safety



CAUTION

Improper Operation

Do Not Operate this equipment other than as specified by the manufacturer

- Only qualified personnel, physically capable of operating the equipment and with no impairments in their judgment or reaction times, should operate this equipment.
- Read all system component manuals before operating this equipment. A thorough understanding of system components and their operation will help you operate the system safely and efficiently.
- Before starting this equipment, check all safety interlocks, fire-detection systems, and protective devices such as panels and covers. Make sure all devices are fully functional. Do not operate the system if these devices are not working properly. Do not deactivate or bypass automatic safety interlocks or locked-out electrical disconnects or pneumatic valves.
- Protect equipment with safety devices as specified by applicable safety regulations.
- If safety devices must be removed for installation, install them immediately after the work is completed and check them for proper functioning.
- Route electrical wiring along a protected path. Make sure they will not be damaged by moving equipment.
- Never operate equipment with a known malfunction.
- Do not attempt to operate or service electrical equipment if standing water is present.
- Use this equipment only in the environments for which it is rated. Do not operate this equipment in humid, flammable, or explosive environments unless it has been rated for safe operation in these environments.
- Never touch exposed electrical connections on equipment while the power is ON.

Failure to follow these instructions can result in serious injury, death or equipment damage.

1.1.6 Maintenance Safety



DANGER

ELECTRIC SHOCK HAZARD

THIS EQUIPMENT MAY CONTAIN ELECTROSTATIC DEVICES

- DO NOT OPERATE A SYSTEM THAT CONTAINS MALFUNCTIONING COMPONENTS. IF A COMPONENT MALFUNCTIONS, TURN THE SYSTEM OFF IMMEDIATELY.
- DISCONNECT AND LOCK OUT ELECTRICAL POWER.
- ALLOW ONLY QUALIFIED PERSONNEL TO MAKE REPAIRS OR REPLACE MALFUNCTIONING COMPONENTS ACCORDING TO INSTRUCTIONS PROVIDED IN MANUAL.

FAILURE TO FOLLOW THESE INSTRUCTIONS CAN RESULT IN DEATH OR EQUIPMENT DAMAGE

1.1.7 Touch Current



WARNING

Touch current exceeds 3.5mA AC. The minimum size of the PE conductor shall comply with the local safety regulations for high PE conductor current equipment.

2.0 Description

Figure 1: Series circuit system overview

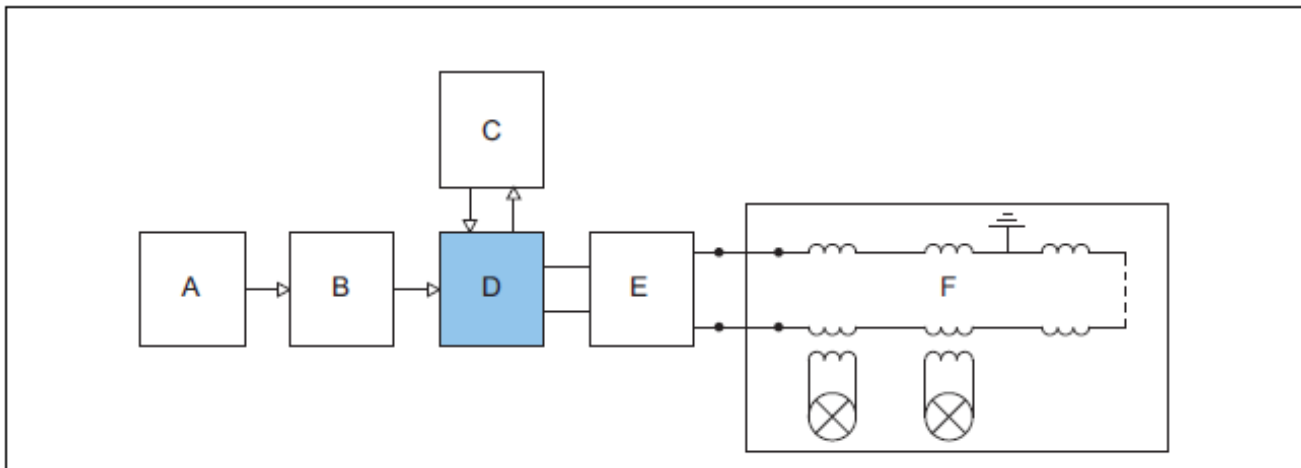

A Input power supply

B Manual switch

C Remote control system

D Equipment

E Output disconnection device (optional)

F Series circuit

The equipment is a microprocessor-controlled Constant Current Regulator with an optional output disconnection device (circuit selector).

2.1 Intended Use

The equipment is designed to convert an AC sine wave input voltage into an adjusted output current selected in brightness steps to supply a series AGL circuit.

Any other or additional use will not considered to be in conformity with the purpose.

Do not operate the equipment outside the limits of the specifications or outside the specified ambient conditions.

2.2 Working Principle

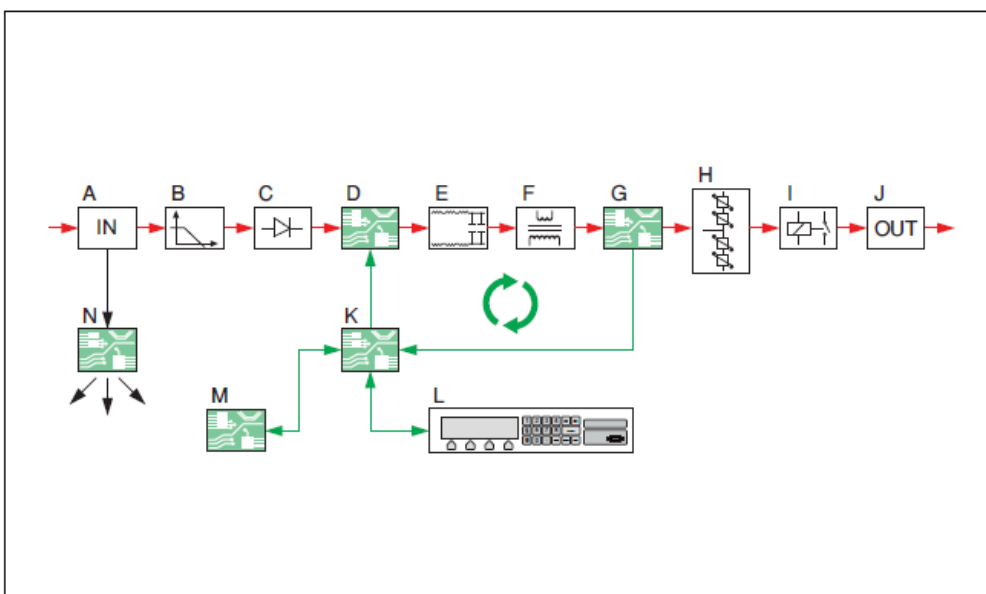

A	Line input. See Line input
B	Input filter. See Input filter
C	Diode bridge and sensing PCB, components of the IGBT power bridge. See IGBT power bridge
D	IGBT module and IGBT PCB, components of the IGBT power bridge. See IGBT power bridge
E	Output filter. See Output filter
F	Main transformer. See Main transformer, all cabinets
G	Output measure PCB. See Output measure PCB (EPS422), all cabinets
H	Lightning arrestors. See Power output
I	Circuit selector (optional). See Circuit selector (CS)
J	Series output connection. See Remote control
K	CPU PCB. See CPU PCB (EPS479), all cabinets
L	HMI. See HMI
M	Remote control PCB. See Remote control PCB (EPS495 or EP00047), all cabinets
N	Power supply PCB. See Power supply PCB (EPS480), all cabinets

Legend

- Red lines: current
- Green lines: signal wires connections
- Black lines: low voltage connections

Current regulation

The equipment converts the single phase input voltage line into a rectified current and voltage. The equipment then converts this DC current and voltage into a pure sine wave with a defined power rating.

Main feedback loop

The output measure PCB sends the measured output to the CPU PCB. Depending on the output, the CPU PCB automatically generates a signal to adjust the regulation.

2.3 Layout of the Equipment Cabinet

2.3.1 Outside - stackable cabinet 2.5 kVA

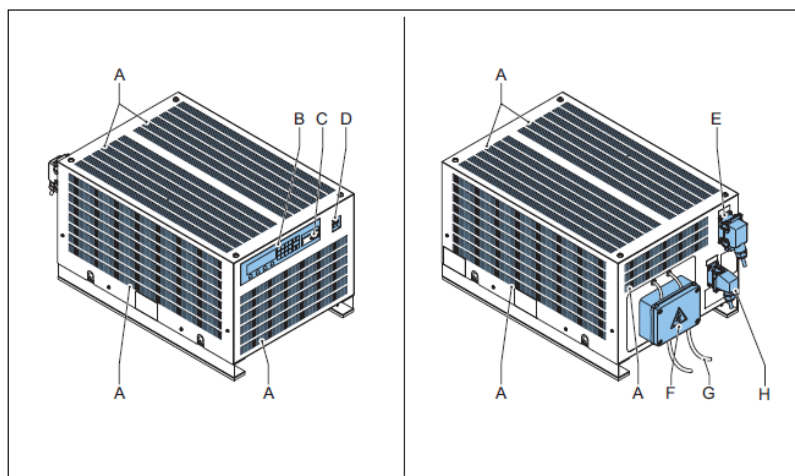

A	Ventilation grids
B	HMI
C	Serial communication port
D	Manual switch
E	Remote control connector
F	Series output connection. The illustration shows the SCB.
G	Output to Series Circuit
H	Power supply connector

2.3.2 Inside - stackable cabinet 2.5 kVa

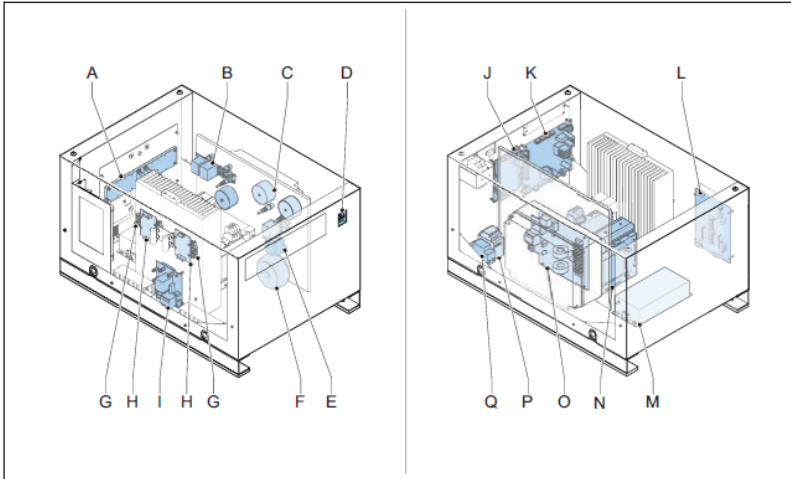

A	Lightning arrestors
B	Input filter
C	Output filter
D	Manual switch
E	Sensing transformer
F	Power supply transformer
G	IGBTs
H	IGBT-PCBs (EPS477)
I	Diode bridge + sensing PCB (EPS476)
J	CPU PCB (EPS479)
K	Power supply PCB (EPS480)
L	Remote control PCB (EPS495 or EP00047)
M	Line filter
N	Main transformer
O	Output measure PCB (EPS442)
P	Main contactor
Q	Main fuses

2.3.3 Outside - small cabinet: 2.5 to 15 kVA

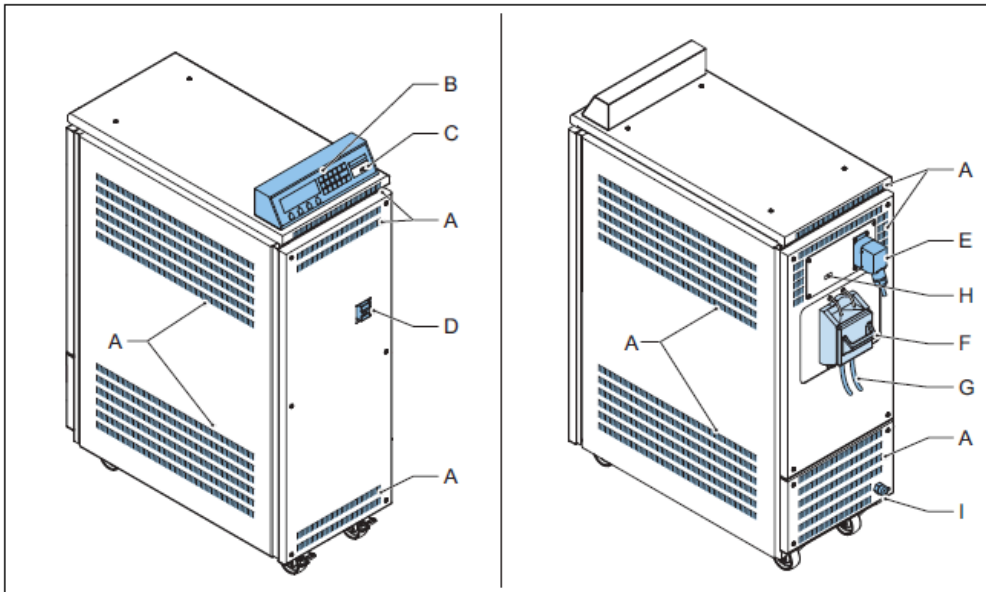

A	Ventilation grids
B	HMI
C	Serial communication port
D	Manual switch
E	Remote control connector
F	Series output connection. The illustration shows the SCO
G	Output to Series Circuit
H	Ethernet connector
I	Power supply cable entry

2.3.4 Inside - small cabinet: 2.5 to 15 kVA



Note

The illustrations show the 10 kVA cabinet.

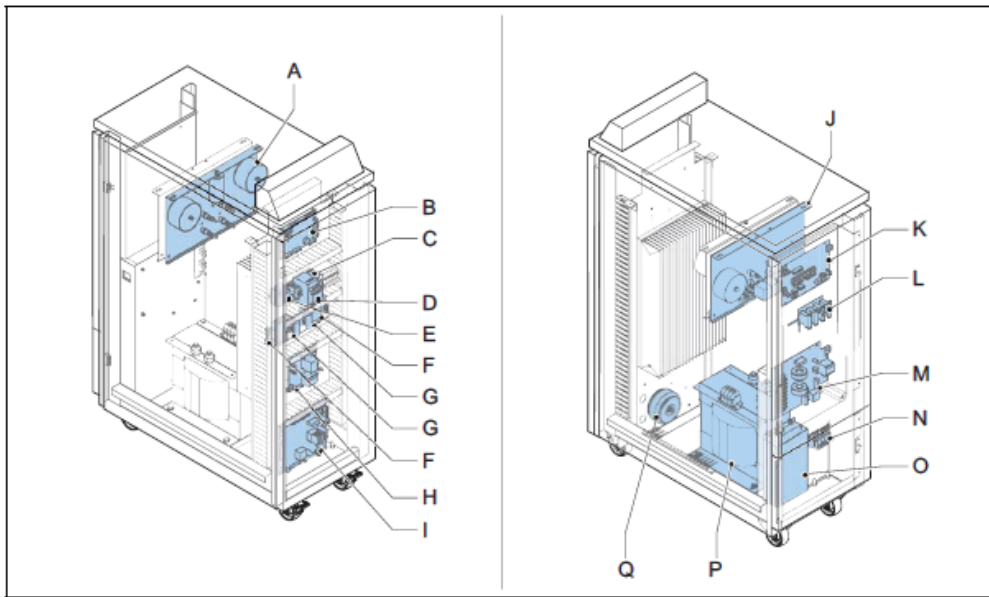

A	Output filter
B	CPU PCB
C	Main fuses
D	Main contactor
E	Sensing transformer
F	IGBT
G	IGBT PCB (EPS477)
H	Diode bridge and sensing PCB (EPS476 / EPS507)
I	Power supply PCB (EPS480)
J	Input filter
K	Remote control PCB (EPS495 or EP00047)
L	Lightning arrestors
M	Output measure PCB (EPS442)
N	Input terminals
O	Line filter
P	Main transformer
Q	Power supply transformer

2.3.5 Outside - small cabinet: 2.5 to 15 kVA with CS (option CS)

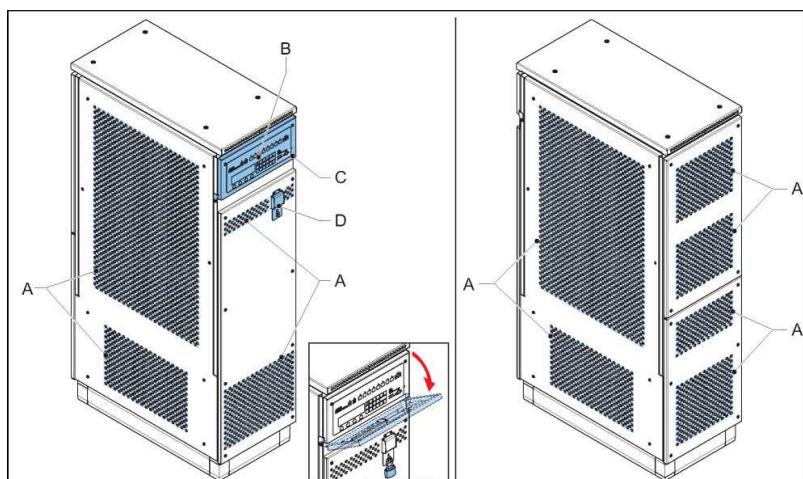

A	Ventilation grids
B	HMI
C	Serial communication port
D	Manual switch with lockable cover

2.3.6 Inside - small cabinet: 2.5 to 15 kVA with CS (option CS)



Note

The illustration shows only the items of the CS. For all other items, see [Inside - small cabinet: 2.5 to 15 kVA](#).

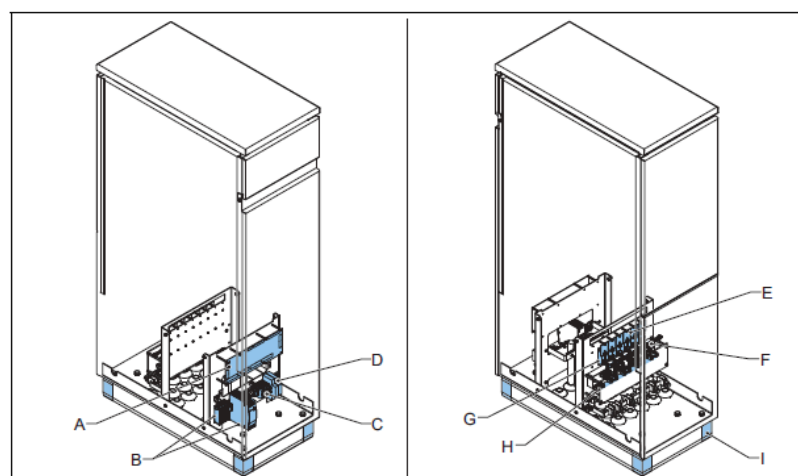

A	Interface PCB (PCB1702)
B	Power supply converters for multiwire remote control
C	Input terminals
D	Lightning arrestors
E	CS PCB (PCB1619)
F	Current sensors
G	CS relays
H	Connection terminals for the primary circuit
I	Supports

2.3.7 Outside - big cabinet 20 to 30 kVA

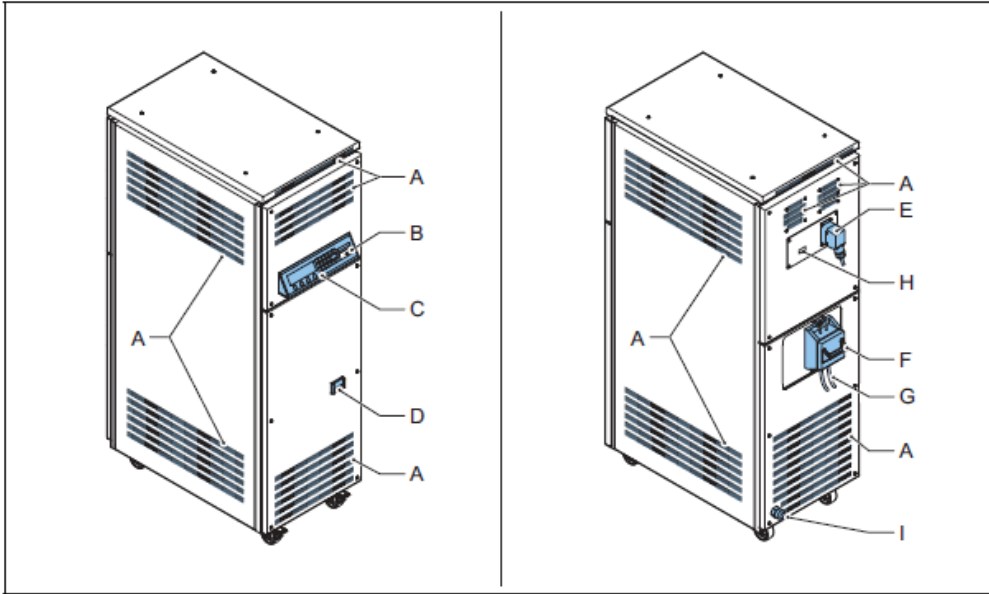

A	Ventilation grids
B	HMI
C	Serial communication port
D	Manual switch
E	Remote control connector
F	Series output connection. The illustration shows the SCO
G	Output to Series Circuit
H	Ethernet connector
I	Power supply cable entry

2.3.8 Inside - big cabinet 20 to 30 kVa

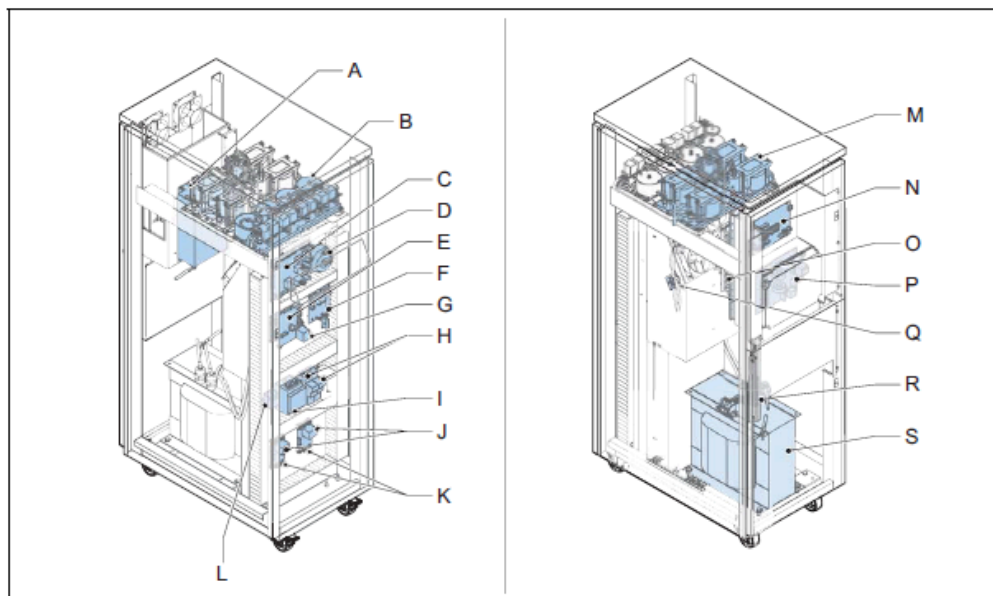

A	Line filter
B	Input filter
C	Power supply PCB (EPS480)
D	Power supply transformer
E	CPU PCB (EPS479)
F	Sensing PCB (EPS476)
G	Diode Bridge
H	Main fuses
I	Main contactor
J	IGBT-PCBs (EPS496)
K	IGBTs
L	Sensing transformer
M	Output filter
N	Remote control PCB (EPS495 or EP00047)
O	Lightning arrestors
P	Output measure PCB (EPS442)
Q	Hall sensor
R	Input terminals
S	Main transformer

2.3.9 Outside - big cabinet: 20 to 30 kVA with CS (option CS)

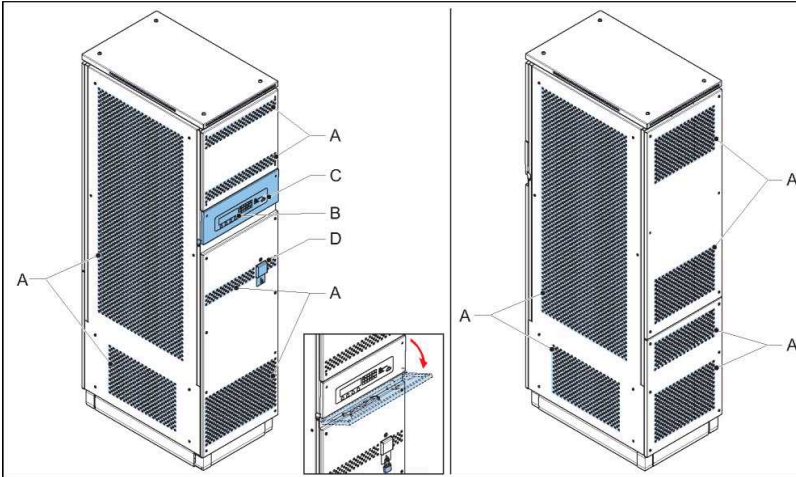

A	Ventilation grids
B	HMI
C	Serial communication port
D	Manual switch

2.3.10 Inside - big cabinet: 20 to 30 kVA with CS (option CS)



Note

The illustration shows only the items of the CS. For all other items, see [Inside - small cabinet: 2.5 to 15 kVA](#).

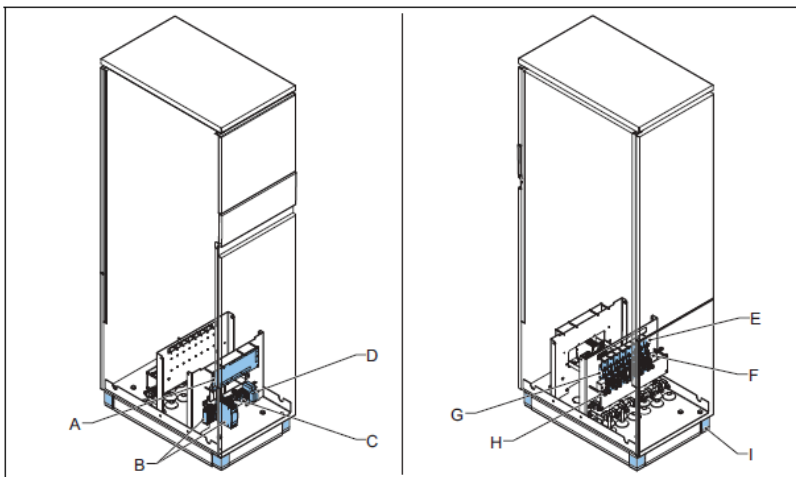

A	Interface PCB (PCB1702)
B	Power supply converters for multiwire remote control
C	Input terminals
D	Lightning arrestors
E	CS PCB (PCB1619)
F	Current sensors
G	CS relays
H	Connection terminals for the primary circuit
I	Supports

2.4 Components

For the exact location and connectors see [Layout of the Equipment Cabinet](#) and the electrical scheme. You can find the electrical scheme attached on the outside of the equipment.

2.4.1 Line input

Figure 2: Input terminal, all cabinets

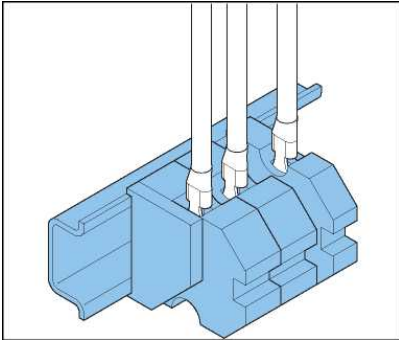

The input terminal connects the power input cables to the equipment.

Figure 3: Line filter, all cabinets

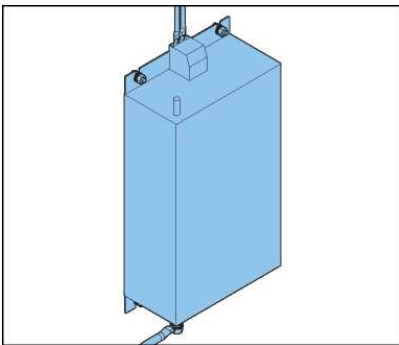

The line filter blocks the noise the equipment generates to the line input and filters out voltage pulses from the input voltage.

Figure 4: Manual switch, all cabinets

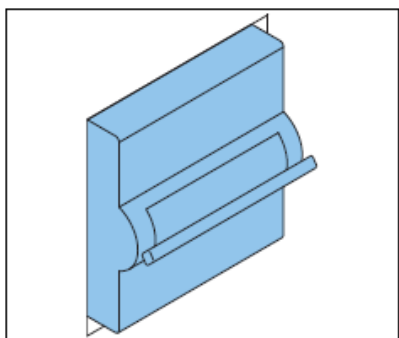

The manual switch is a magneto-thermal switch that connects the mains power supply to the equipment. You can manually set the switch to the **ON** or **OFF** position.

Figure 5: Main fuses, all cabinets

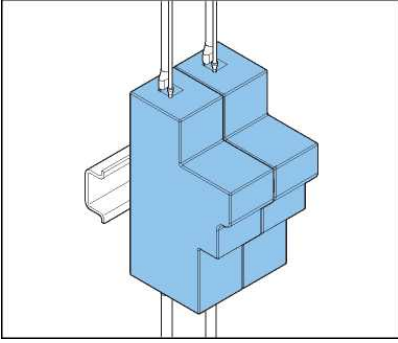

The main fuses disconnect the equipment from the mains power supply if the input current is above a given value.

Figure 6: Main contactor, stackable cabinet and small cabinet

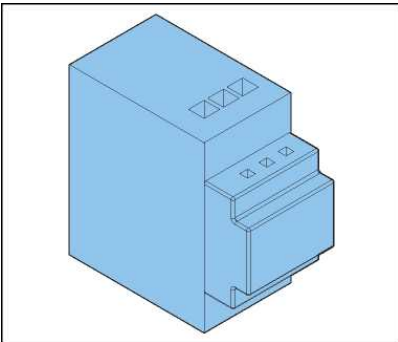

The main contactor allows the power supply PCB to automatically interrupt the power.

Figure 7: Main contactor, big cabinet

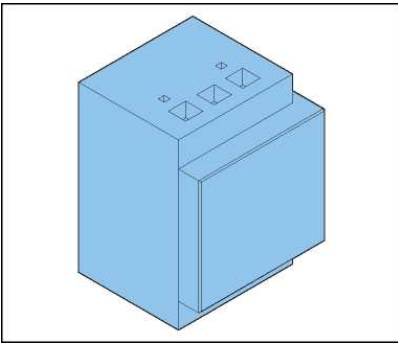

The main contactor allows the power supply PCB to automatically interrupt the power.
The resistors on the precharge PCB limit the current for the precharge of the capacitor bank.

Figure 8: Sensing transformer, all cabinets

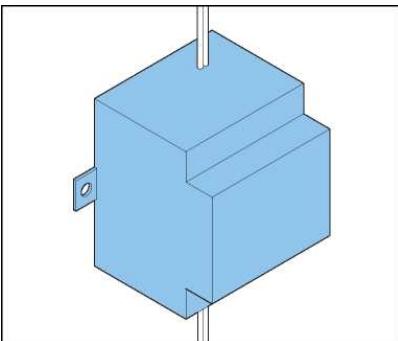

The sensing transformer measures the input voltage level of the line input.

Figure 9: Power supply transformer, all cabinets

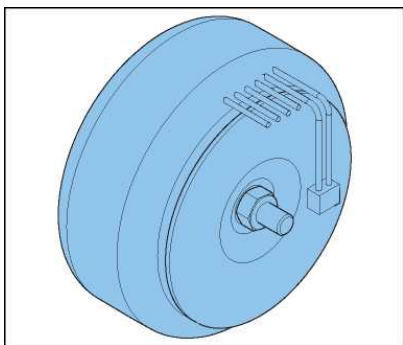

The power supply transformer:

- Supplies the zero crossing signal determined from the input voltage.
- Provides the correct current and voltage to power all the electronic components such as PCBs and to power the fans (for 15 to 30kVA equipment).

2.4.2 Input filter

Figure 10: Input filter, stackable cabinet and small cabinet (except 15 kVA)

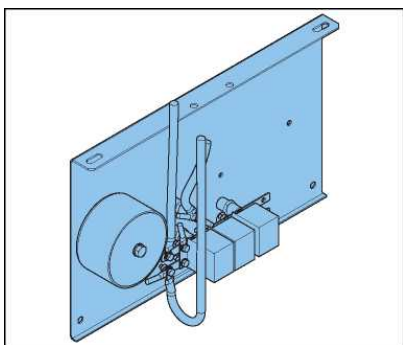

The input filter is a 12.5 kHz filter that blocks the noise the equipment produces from the line input at a different frequency than the line filter.

Figure 11: Input filter, 15 kVA small cabinet and big cabinet

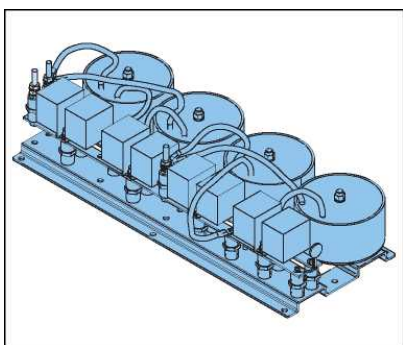

The input filter is a 12.5 kHz filter that blocks the noise the equipment produces from the line input at a different frequency than the line filter.

2.4.3 IGBT power bridge

The IGBT power bridge has the following components:

- Diode bridge + sensing PCB
 - IGBT PCB
 - IGBT
-



WARNING

If one of these three components breaks, replace the entire IGBT power bridge.

Figure 12: Diode bridge + sensing PCB (EPS476 /EPS507), stackable cabinet and small cabinet

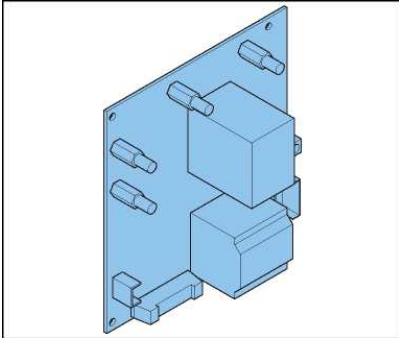

The diode bridge converts the AC line input to a rectified current and voltage.

The sensing PCB measures the AC input line.



Note

In the stackable cabinet and the small cabinet, the sensing PCB and the diode bridge are combined into one part.

Figure 13: Sensing PCB (EPS476), big cabinet

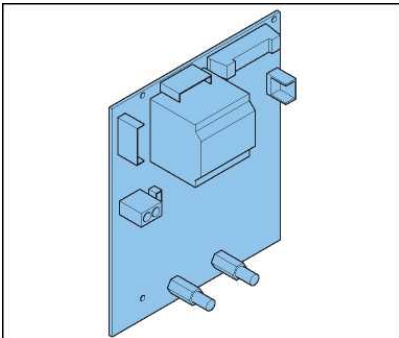

The sensing PCB measures the AC input line and controls the diode bridge.



Note

In the big cabinet, the sensing PCB and the diode bridge are separate parts.

Figure 14: Diode bridge, big cabinet

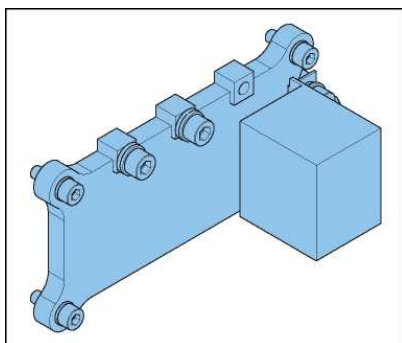

The diode bridge converts the AC line input to a rectified current and voltage.



Note

In the big cabinet, the sensing PCB and the diode bridge are separate parts.

Figure 15: IGBT, all cabinets

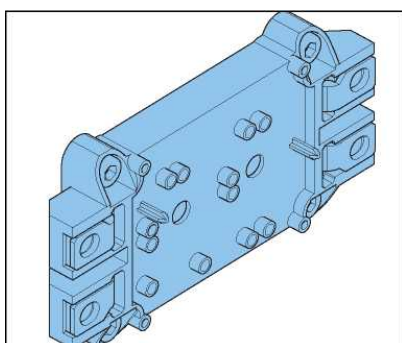

An IGBT controls a high power via a low power electronic signal.

The IGBT can switch at high frequency.

Two IGBTs are installed together in one housing.

The system uses four IGBTs connected as an H-bridge to make an AC-signal.

Figure 16: IGBT PCB (EPS477 /EPS496 /EPS 478), all cabinets

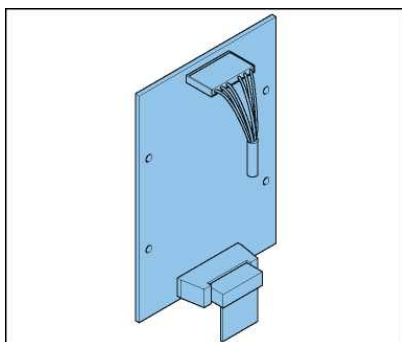

The IGBT PCB measures the output signal from the IGBT H-bridge.

2.4.4 Hall sensor, big cabinet

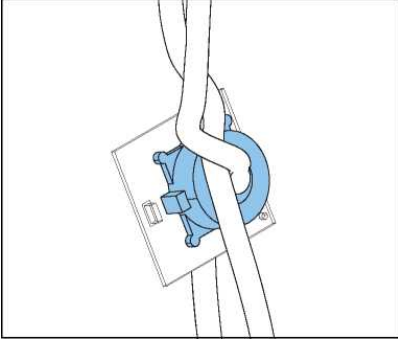

The Hall sensor measures the current between the IGBT and the output filter.

2.4.5 Output filter

Figure 17: Output filter, stackable cabinets and small cabinet (except 15 kVA)

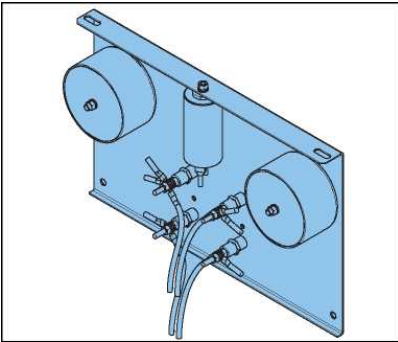

The output filter is a Pulse Width Modulation (PWM) filter that builds the pure sine wave signal that comes from the H-bridge.

Figure 18: Output filter, 15 kVA small cabinet and big cabinet

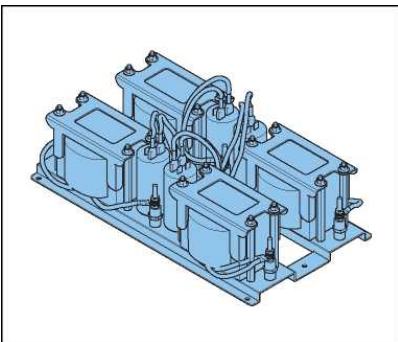

The output filter is a Pulse Width Modulation (PWM) filter that builds the pure sine wave signal that comes from the H-bridge.

2.4.6 Main transformer, all cabinets

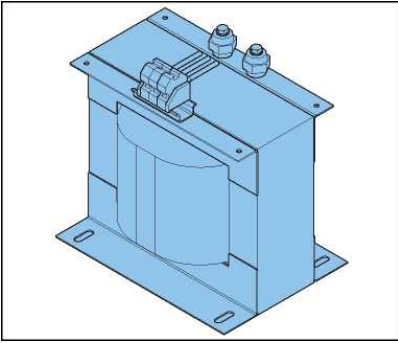

The main transformer converts the pure sine wave to the correct output voltage and current.

2.4.7 Output measure PCB (EPS422), all cabinets

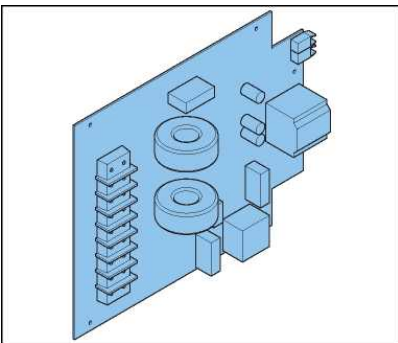

The output measure PCB measures the output voltage and current and sends these measurements to the CPU PCB.

The EFD (See [Earth Fault Detection \(EFD\)](#)) and LFD (See [Lamp Fault Detection \(LFD\)](#)) logic is also located on the output measure PCB.

2.4.8 Power output

Lightning arrestors, all cabinets

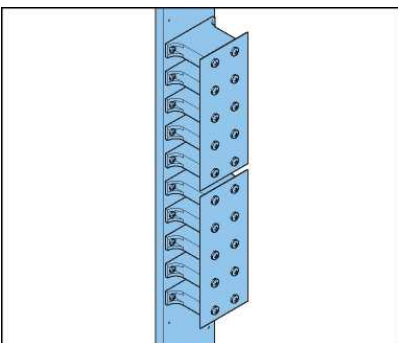

- The lightning arrestors are installed on the power output. The lightning arrestors are varistors.
- A varistor is a surge protection device that is connected directly across the AC output.

Connection to the series circuit

- There are mutual exclusive options possible. See [Options](#).

2.4.9 CPU PCB (EPS479), all cabinets

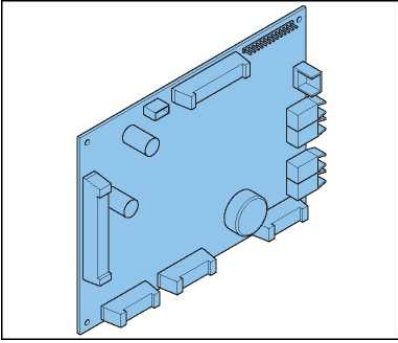

The CPU PCB:

- Receives the measurement data of the output current and voltage from the output measure PCB via an optical fibre and compares these values with the required values. A software algorithm processes this data to adjust the signals from the output filters.
- Receives and processes input signals from the HMI and the remote control PCB.

2.4.10 Remote control PCB (EPS495 or EP00047), all cabinets



Note

Until 2022, the CRE was delivered with the EPS495 board as the remote control PCB. Since 2022, the CRE has been delivered with the EP00047, and the EP00051 as an add-on board when Multiwire is required. The functionalities of these boards are equivalent in most cases, with the exception of the most demanding recent ALCMS systems with a redundant bus. For CRE units equipped with the EPS495, there are options to transition to the EP00047 (and the EP00051 add-on if needed) when required. Please contact your ADB SAFEGATE representative for more details if needed.

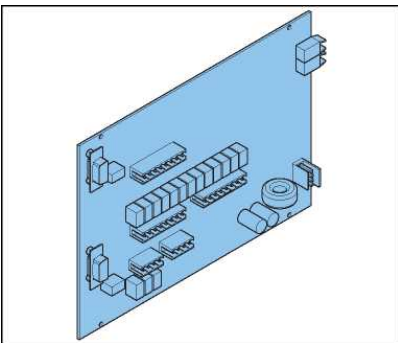

The equipment can be monitored or controlled remotely with J-Bus (2-wire RS485), multiwire or ethernet. This remote control allows the remote control system to:

- Receive information about the equipment.
- Configure the brightness steps.
- Test the equipment.

The remote control PCB connects the equipment to the remote control system. The internal connection between the remote control PCB and the CPU PCB goes through an optical fibre.



Note

For EPS495, remote control through an ethernet connection requires an additional PCB. See [Ethernet PCB \(EPS542\)](#), all cabinets.



Note

For EP00047, Multiwire support requires an add-on PCB, EP00051.

2.4.11 Power supply PCB (EPS480), all cabinets

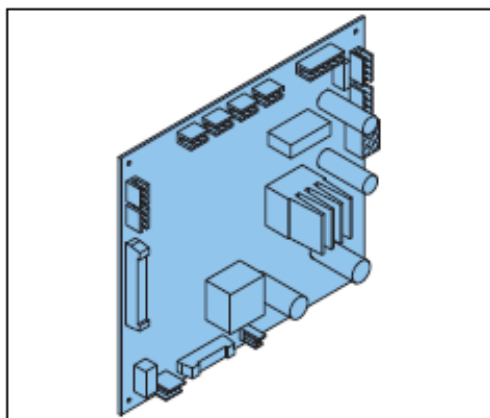

The power supply PCB provides the power supply for:

- All electronic components such as PCBs of the equipment
- The fans (for 15 to 30 kVA equipments)
- The control for the main contactor

The power supply PCB also manages the safety switches on the panels.

2.4.12 Lamp Fault Detection (LFD)

The equipment analyses the output current and the voltage pattern to calculate, on a linear load, the number of open circuited lamps, in compliance with IEC 61822:2009.

The accuracy is ± 1 lamp with a range from 1 to 15 broken lamps.

The HMI shows the actual LFD value.

2.4.13 Earth Fault Detection (EFD)

The EFD measures the insulation resistance between the series circuit and the earth in compliance with IEC 61822:2009.

The EFD module works when the equipment is connected to the mains supply, even if no output current is present.

You can set two alarm levels, Level 1 and Level 2, for the measured values. Both alarm levels can be set to any value between 5 kOhm and 500 MOhm. However, Level 1 must always be higher than Level 2.

Working principle: A high-voltage resistor applies a stable, current-limited voltage of 450 VDC between the series circuit and the earth or cable screen.

The HMI shows the actual EFD value.



Note

EFD measurement is done through a DC voltage with a positive voltage applied on to the series circuit and the 0 (zero) to the earth.

2.5 Options

2.5.1 Remote control



Note

Until 2022, the CRE was delivered with the EPS495 board as the remote control PCB. Since 2022, the CRE has been delivered with the EP00047, and the EP00051 as an add-on board when Multiwire is required. The functionalities of these boards are equivalent in most cases, with the exception of the most demanding recent ALCMS systems with a redundant bus. For CRE units equipped with the EPS495, there are options to transition to the EP00047 (and the EP00051 add-on if needed) when required. Please contact your ADB SAFEGATE representative for more details if needed.

The following remote control connections are possible:

- Ethernet (Ethernet PCB required for EPS495)
 - Single
 - Double
- J-Bus
 - Single
 - Double
- Multiwire with 8 input signals and 17 output signals, always possible to monitor via single J-Bus. For CRE units equipped with EP00047, the add-on board EP00051 is also required.

2.5.2 Ethernet PCB (EPS542), all cabinets



Note

This applies to CRE units equipped with EPS495.

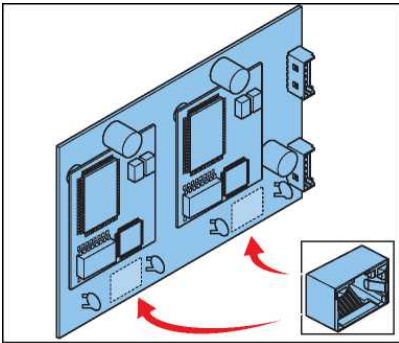

The ethernet PCB converts the ethernet to an RS-485 signal. This PCB is required for EPS495 if you need to remotely operate the equipment through an ethernet connection.

The illustration shows a double ethernet connection.

2.5.3 Multiwire PCB (EP00051), all cabinets

The EP00051 is a mezzanine board which is designed for multiwire connection support for CRE units since 2022. This board is required in addition to the EP00047 if you need to remotely operate the equipment through a multiwire connection.

2.5.4 Circuit selector (CS)

With a CS you can connect several (up to eight) series circuits to a single equipment.

The CS has two modes:

- Simultaneous: the equipment can connect to a number of the available circuits at the same time

- Alternate: the equipment can connect to only one circuit at a time

2.5.5 Lightning arrestors (option CS)



Note

This item is installed on the CS when the CS option is chosen.

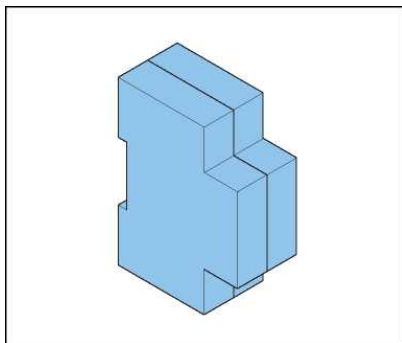

The additional lightning arrestors for the CS are installed on the power output. The lightning arrestors are varistors. A varistor is a surge protection device that is connected directly across the AC output.

2.5.6 Interface PCB (PCB1702) (option CS)



Note

This item is installed on the CS when the CS option is chosen.

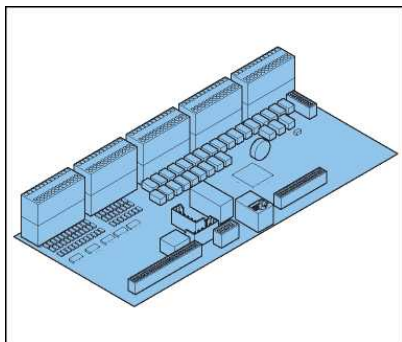

The interface PCB is the remote control interface PCB of the equipment, if the equipment has a CS.

2.5.7 CS PCB (PCB1619) (option CS)



Note

This item is installed on the CS when the CS option is chosen.

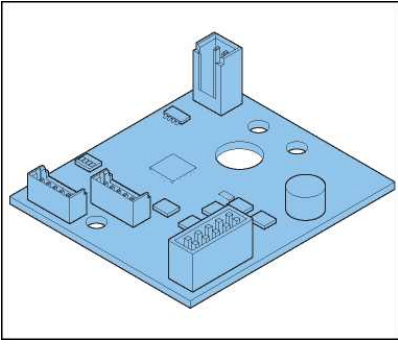

The CS PCBs drive the CS relays through CANbus and measure the current after the relay with a current sensor. (see [Current sensor \(option CS\)](#)).

2.5.8 HMI SIN PCB (PCB1703) (option CS)

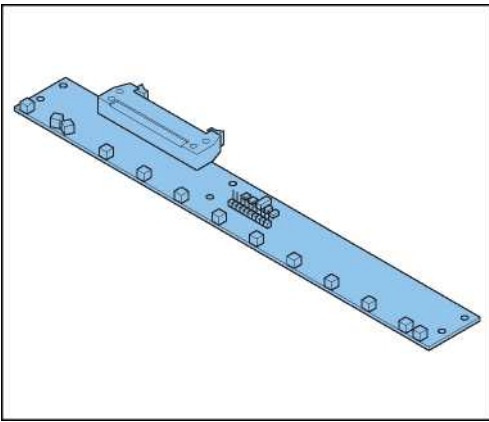

Note

This item is installed on the CS when the CS option is chosen.

The HMI SIN BCB provides the indication of the state of the different series circuits (selected or not selected).

2.5.9 Remote control SIN PCB (PCB1694) (option CS)



Note

This item is installed on the CS when the CS option is chosen.

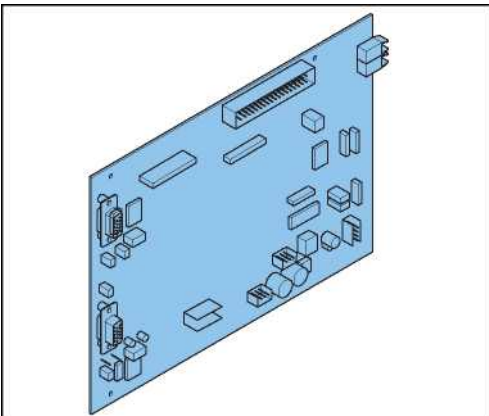

The remote control SIN PCB is the interface between the CPU PCB and the interface PCB

2.5.10 CS relay (option CS)

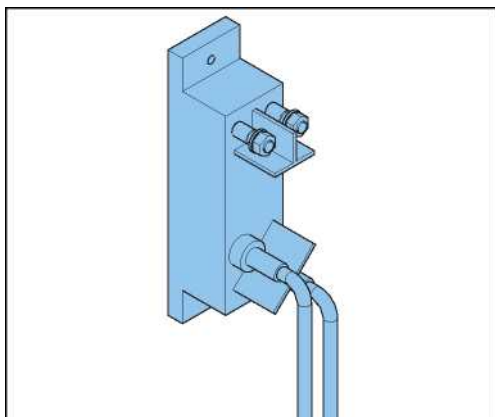

Note

This item is installed on the CS when the CS option is chosen.

The CS relays switch on or off its designated series circuit.

2.5.11 Current sensor (option CS)

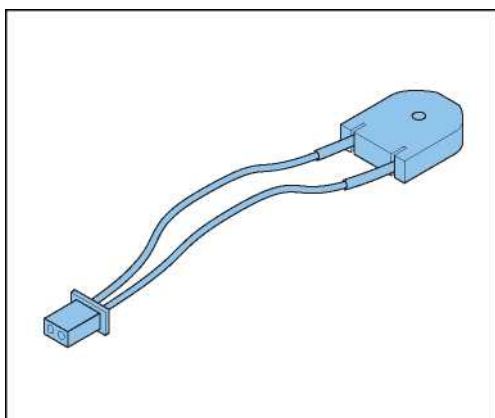

Note

This item is installed on the CS when the CS option is chosen.

The current sensors sense current running through the series circuits.

2.5.12 Series Connector Box (SCB), all cabinets

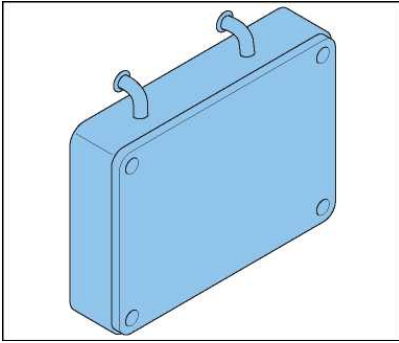

The SCB connects the equipment to the series circuit with two medium voltage cables of the primary circuit. The SCB does not allow the short circuit connection.

2.5.13 Series CutOut (SCO), all cabinets

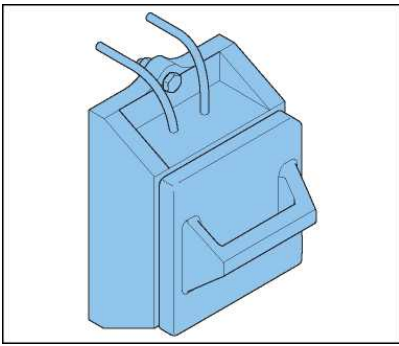

The SCO acts as an output disconnection device between the equipment and the series circuit. The SCO also isolates the series circuit from the equipment during maintenance or testing operations. The cover is locked with a key to prevent unauthorized access.

2.5.14 Rolling castors

The equipment can be supplied with two fixed and two pivoting rolling castors to facilitate the movement of the equipment. The option is not available for stackable equipments or for an equipment with a CS.

2.6 HMI

You can operate the equipment with the HMI.

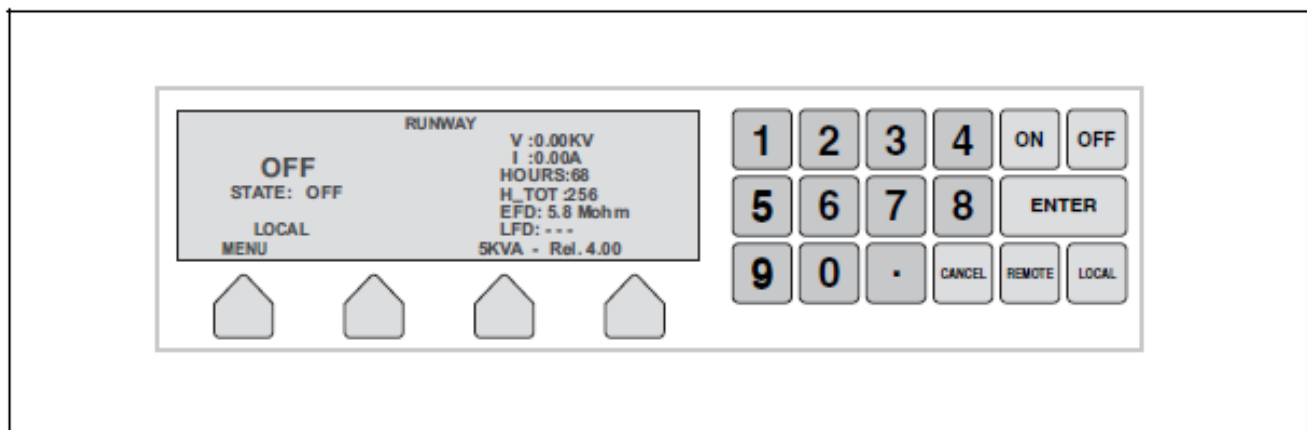

2.7 HMI of an equipment with CS (option CS)

You can operate the equipment with the HMI.

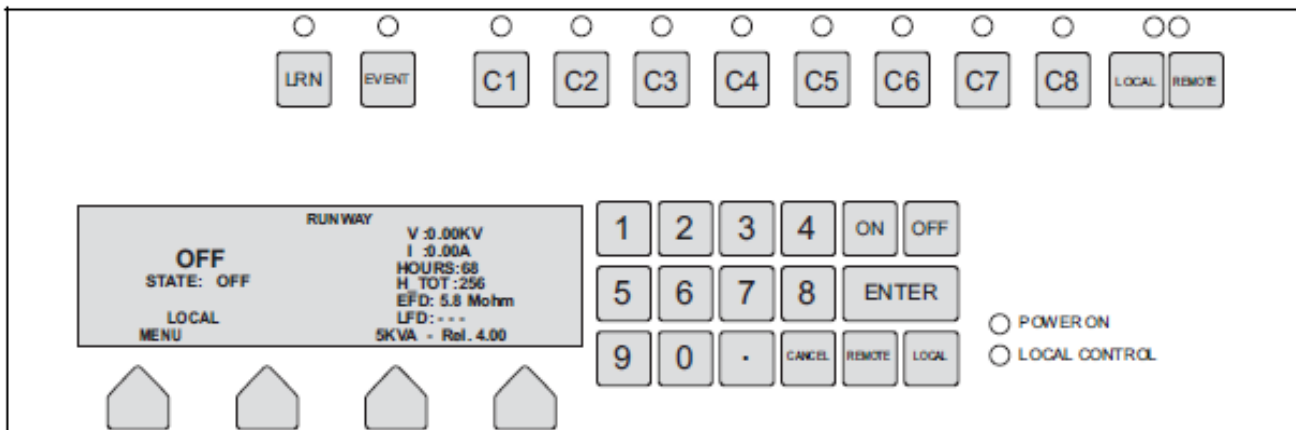

2.8 Nameplate

Each equipment has a standard nameplate:

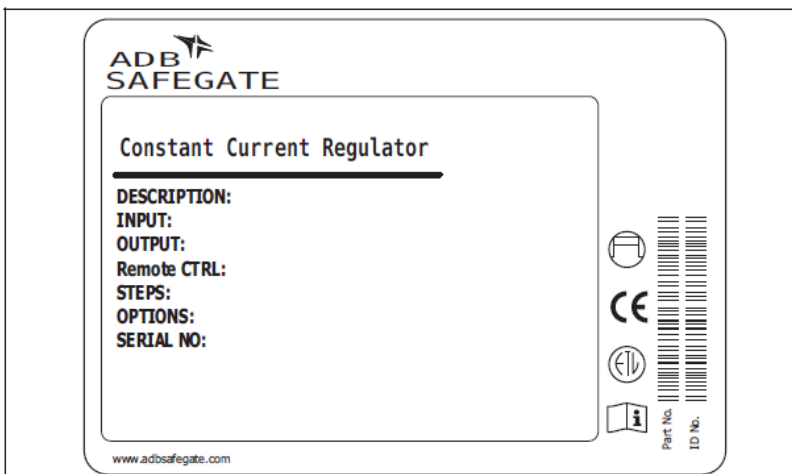

3.0 Description of the HMI

Figure 19: HMI overview

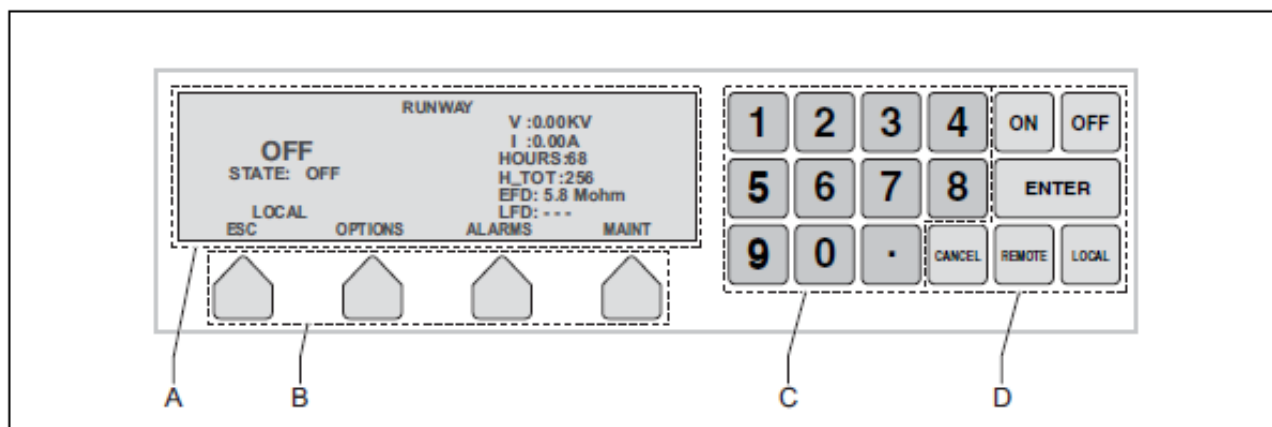

- A. Display
- B. Function buttons
- C. Keypad
- D. On, Off, Enter, Cancel, Remote and Local buttons

3.1 HMI overview for an equipment with a CS (option CS)



Note

The HMI of an equipment has the standard HMI (see [Description of the HMI](#)), with an extra set of buttons and indicators.

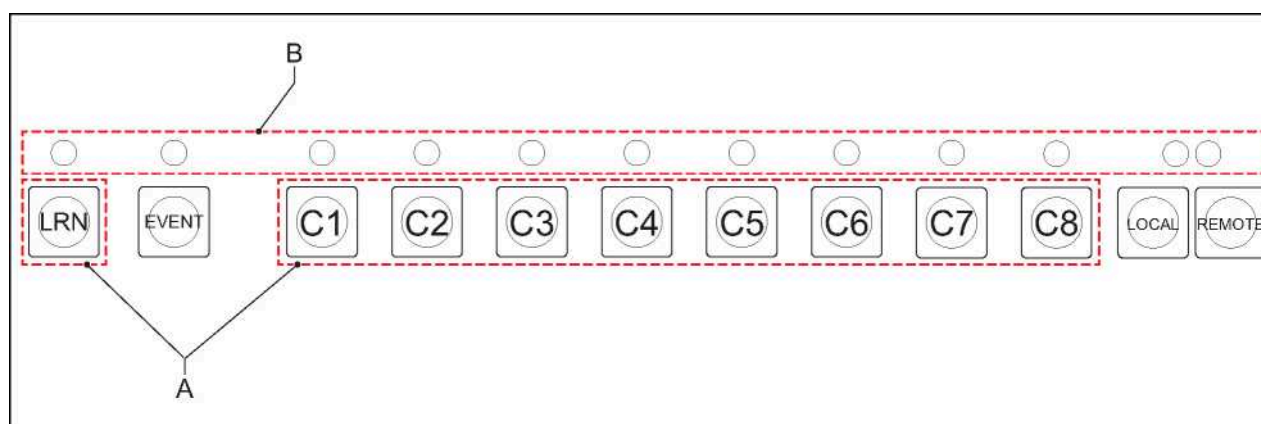

A	Function buttons
B	Function indicator LEDs

The LED's for the function buttons C1 to C8 are **On** if the circuit is selected. The LEDs are **Off** when the circuit is not selected. The LRN function button is not used.

LED	LED colour	Description
CS ON	Green	The equipment and the CS are active
EVENT	Red	An alarm is active

LED	LED colour	Description
LOCAL	Red	The equipment and the CS are in local mode ¹
REMOTE	Green	The equipment and the CS are in local mode ¹

3.2 Display overview: Main screen

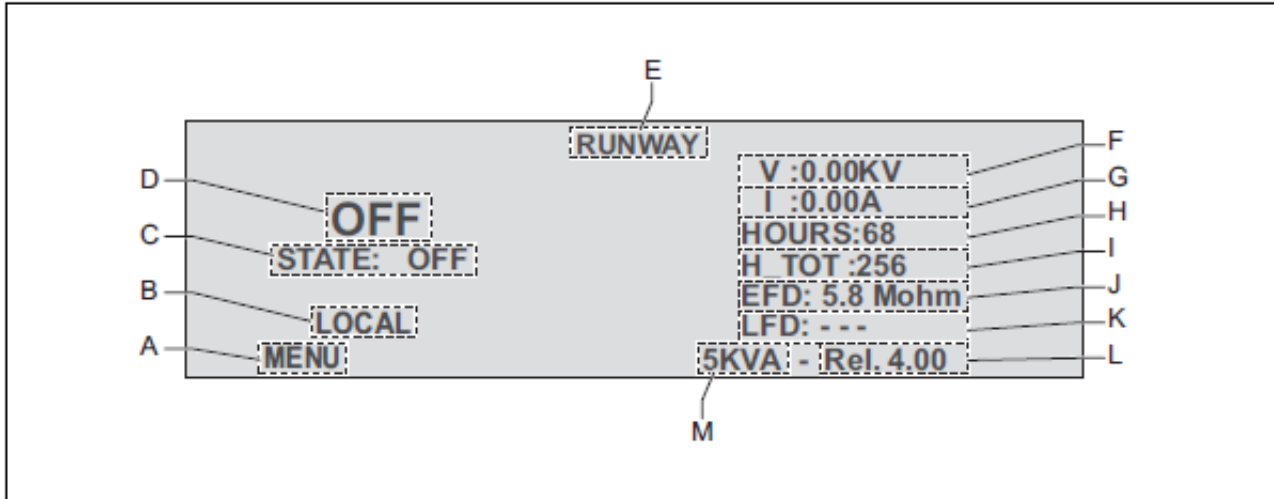

Table 1: Display description: Main screen

Name	Description
A Menu	Push the corresponding function button to go to the Main menu
B Mode indication	Shows the state, LOCAL or REMOTE
C State	The state can be OFF or ON
D Brightness level	OFF, or BRIGHTNESS 0 to 5. Optionally, more levels are possible. If the display shows BRIGHTNESS 0, this means that the equipment has a pre-defined current as output, due to a remote control loss
E Field circuit	Shows the name of the field circuit that the equipment delivers power to
F True RMS output voltage	Shows the true RMS output voltage in kV
G True RMS output current	Shows the true RMS output current in A
H Highest brightness step counter	Shows the time that the equipment operates at the maximum brightness step in h
I Total brightness counter	Shows the total time that the equipment is set to 'on' in h
J EFD indicator	Shows the measurement of the resistance to earth. The equipment continuously measures the value, also when the equipment is in the OFF state, when the equipment has power
K LFD indicator	In normal mode (linear load): Shows the number of broken lamps if the LFD is calibrated In inductive mode (non-linear load): Shows the text 'inductive'
L Software version	Shows the current software version
M Power rating	Shows the power rating of the equipment

¹You can only select local or remote control on the equipment

3.3 Description of general functions

The buttons can have different functions. The display description indicates the dedicated functions. This section shows the general functions, which are available in several menus.

Table 2: General function buttons

Button	Description
→	To go to the next submenu
←	To go to the previous submenu
ESC	To go to the higher level menu
-	To decrease the value
+	To increase the value
YES	To confirm the selection
NO	To decline the selection
SAVE	To save an alphanumeric or numeric string
UP, DOWN, LEFT, RIGHT	To move the cursor in the display

3.4 Main menu

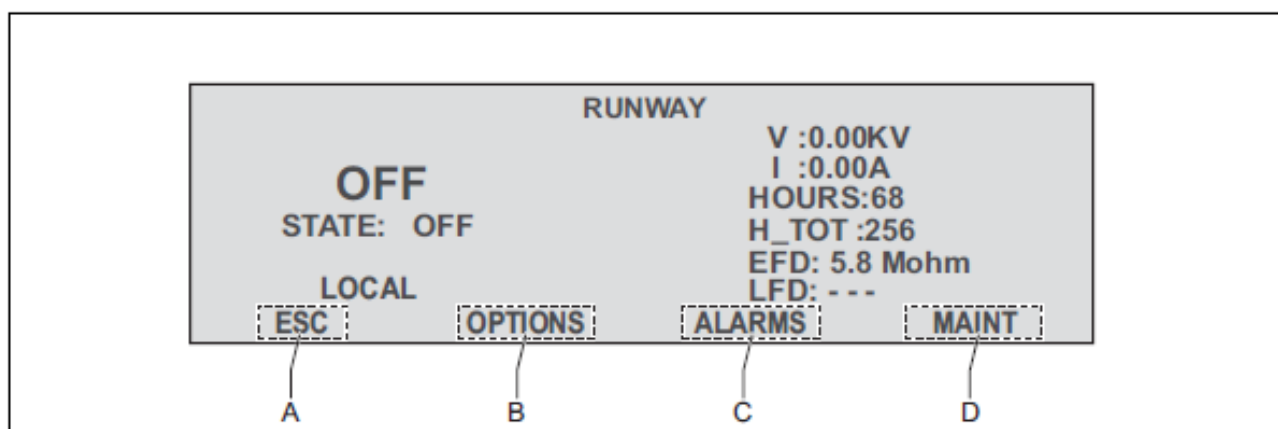

Table 3: Display description: Menu screen

Name	Description
A ESC	To return to the Main menu. See Main menu
B OPTIONS	To go to the Options menu. See Options menu
C ALARMS	To go to the Alarms menu. See Alarms menu
D MAINT	To got to the Maintenance menu. See Maintenance menu

3.5 Options menu

Table 4: Buttons

Button	Description
RS232/485	To activate or deactivate the RS232 or RS485 port
MODE	To select the correct equipment work mode (see Operation mode): <ul style="list-style-type: none">▪ NORMAL (for linear loads)▪ INDUCTIVE (for non-linear loads (e.g. LED loads))
ID	To change the name of the field circuit that the equipment powers. See How to enter an alphanumeric string how to enter an alphanumeric string with the HMI
SLVNUM	To change the address number of the equipment in the RS485 network
LANG	To change the language of the display
CONTR	To change the display contrast
LFD	To calibrate the LFD
HCOUNT	To reset the HOURS indicator

3.6 Alarms menu

Table 5: Buttons

Button	Description
RESET	To reset the alarm: See also Alarms
FORWARD	To show the previous alarm in the list: See also Alarm texts and messages on the HMI .

For an overview of alarm texts and messages, see [Alarm texts and messages on the HMI](#)

3.7 Maintenance menu

A password is required to access the maintenance menu.

Table 6: General function buttons

Button	Description
TEST	Shows the DSP microcontroller operating parameters. These parameters show the state of the software process that controls the equipment. These parameters are only for an advanced user.
MORE	<p>To go to more submenus:</p> <ul style="list-style-type: none"> ▪ IGBT TEST A verification test of the IGBT. ▪ INPUT FREQ Do not change this parameter. ▪ REMOTE CONTROL MODE Multiwire or J-Bus ▪ JBUS PROTOCOL MCR2 protocol or MCR3 protocol ▪ CSE/MODE Activate circuit selector. Yes or No. ▪ JBUS mode 485 or Ethernet mode ▪ MULTIWIRES CONFIGURATION To configure the output pins of the multiwire connector. You can change the connector function with the ON and OFF buttons. To save the configuration, push the ENTER button. ▪ V/I CALIBRATION Do not use this parameter. ▪ ETHERNET CONFIGURATION Only for an equipment with the Ethernet Remote Control PCB. To configure the 2 IP addresses.

3.8 Mode menu

Table 7: General function buttons

Button	Description
RAMP TIME	The time that the equipment takes to change from one brightness step to another, in seconds (0 to 125 s).
HALFWAVE WIDTH	To enhance the current peak. You can decrease the half wave width and so reshape the sinusoidal waveform (50 to 100%). The default value is 100% (no enhancement).
MAX PWM WIDTH	To smoothen the maximum current the equipment can supply to prevent a too high current to run on the lamps. You can reduce maximum power threshold on the PWM cycle (1 to 100%). The default value is 100% (no threshold on the current output).
CURRENT LIMIT	Maximum peak current
PID TYPE	Do not change this parameter

3.9 How to enter an alphanumeric string

1. The display shows an alphanumeric matrix (B).
2. Push the LEFT and RIGHT buttons to select the character.
3. Push the ENTER button. The HMI adds the character to the string (A).
4. Push the CANCEL button to delete the last character.
5. Push the SAVE button to confirm the string.

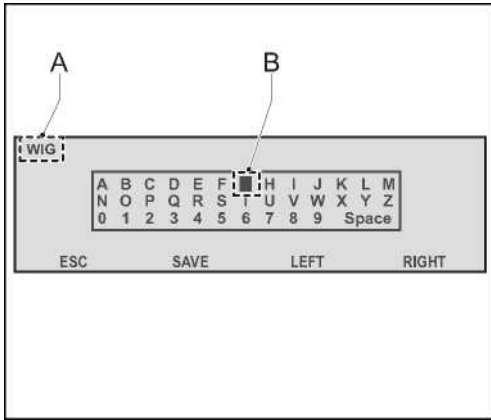

3.10 Alarm texts and messages on the HMI

There are four types of alarms:

- Equipment alarms
 - The equipment automatically switches **OFF**. Restart the equipment only after you have found the cause of the alarm.
 - The red light goes on but the equipment still operates. Find the cause of the alarm.
- Field alarms
 - The equipment automatically switches **OFF**. Restart the equipment only after you have found the cause of the alarm.
 - The red light goes on but the equipment still operates. Find the cause of the alarm.

Alarm text / message	Possible cause	Equipment alarm	Field alarm	Only red light goes on	Equipment switches off automatically
450V EFD MISSING	The 450 V EFD test voltage is missing	x		x	
560VDC BUS OVERCURRENT	The current on the primary power transformer is too high	x			x
ALARM!!!	Several alarms have occurred at the same time	x			x
BAD REGULATION	The current did not reach the selected level within the ramp up time	x		x	
DSP ERROR OR WRONG FIRMWARE	The CPU DSP has failed or the DSP firmware is corrupted	x			x
EFD LEVEL 1 FAULT	The resistance to earth is less than level 1 (20 MOhm default value)		x	x	
EFD LEVEL 2 FAULT	The resistance to earth is less than level 2 (2 MOhm default value)		x	x	
GATE H FAULT	There is a problem with the H-bridge (IGBT). On the HMI, a message shows "IGBT KO: xxx x"	x			x
IGBT KO: ...	Both IGBTs are broken	x		x	
IGBT KO: BTM A	The IGBT A is broken	x		x	
IGBT KO: TOP A	The IGBT A is broken	x		x	
IGBT KO: BTM B	The IGBT B is broken	x		x	
IGBT KO: TOP B	The IGBT B is broken	x		x	

Alarm text / message	Possible cause	Equipment alarm	Field alarm	Only red light goes on	Equipment switches off automatically
IGBT KO: TOP BTM A	The IGBT A is broken	x		x	
IGBT KO: TOP BTM B	The IGBT B is broken	x		x	
INPUT VOLTAGE TOO HIGH	The input voltage is too high	x		x	
INPUT VOLTAGE TOO LOW	The input voltage is too low. This can lead to an over current situation	x			x
LFD LEVEL 1 FAULT	Minimum 3 broken lamps		x	x	
LFD LEVEL level 2 fault	Minimum 5 broken lamps		x	x	
MAIN CONTACTOR FAILED (OFF)	The main contactor is broken	x			x
MAIN CONTACTOR FAILED (ON)	The main contactor is broken	x			x
MAIN DC <95%	The rectified 560 V DC voltage is too low. (Only applies to 3 phase input)	x			x
MAIN REMOTE CTRL SWITCH OFF	The main remote control switch does not go on when the microprocessor gives an 'on' command	x			x
MAIN REMOTE CTRL SWITCH ON	The main remote control switch goes on before the microprocessor gives an 'off' command	x			x
MANY ERRORS HAVE HAPPENED, DURING CONTROL	Different alarms are generated in the same alarm time interval after the equipment startup phase	x			x
MANY ERRORS HAVE HAPPENED, DURING ON	Different alarms are generated in the same alarm time interval during the equipment startup phase	x			x
NO FAN	One or more fans do not operate correctly	x		x	
ONE PHASE MISSING	One phase is missing. The display shows which phase is missing	x			x
OPEN CIRCUIT	The output circuit is interrupted. Link the cable correctly before you restart the equipment		x		x
OVERCURRENT	<ul style="list-style-type: none"> ▪ The output current is more than $I_{max} + 5\%$ for minimum 4s ▪ The output current is more than $I_{max} + 20\%$ for minimum 0.4 s 		x		x
OVERLOAD	The load of the equipment is too high		x	x	
OVERVOLTAGE FROM FIELD	The "IGBT OVP" has stopped the equipment when it could not find a suitable operation mode after several retries		x		x
PHASE ERROR	There is a problem with the mains frequency detection	x		x	
PIC COMMUNICATION ERROR	A faulty communication with the measurement PCB	x			x
PRE-CHARGE CONTACTOR ON	The pre-charge contactor is broken (VIS only)	x			x
PRE-CHARGE CONTACTOR OFF	The pre-charge contactor is broken (VIS only)	x			x
SCO / DOOR OPENED	A front, rear and or field connection panel is open	x			x

Alarm text / message	Possible cause	Equipment alarm	Field alarm	Only red light goes on	Equipment switches off automatically
TEMPERATURE SENSOR FAULT	There is a fault in the temperature measurement circuit	x		x	
TLC ERROR	There is an error on the remote control PCB	x		x	
TOO HIGH TEMPERATURE	The temperature of the heat sink is too high	x		x	
V IN UNSTABLE	The input voltage is not stable	x		x	
VA DROP LEVEL EXCEEDED	The output power goes below a preset level	x		x	

4.0 Description of the configuration software tool

With the configuration software tool, you can:

- Read the state of the equipment (alarms, output current, input current)
- Read the configuration of the equipment
- Adjust the configuration of the equipment
- Test the equipment
- Send writing and reading commands to the equipment



WARNING

When you activate the configuration tool, you transfer all control of the equipment to the configuration software tool. In this situation, remote or local control of the equipment is not possible.

To update the software version, contact ADB SAFEGATE.

4.1 Description of screens and menus

Figure 20: General

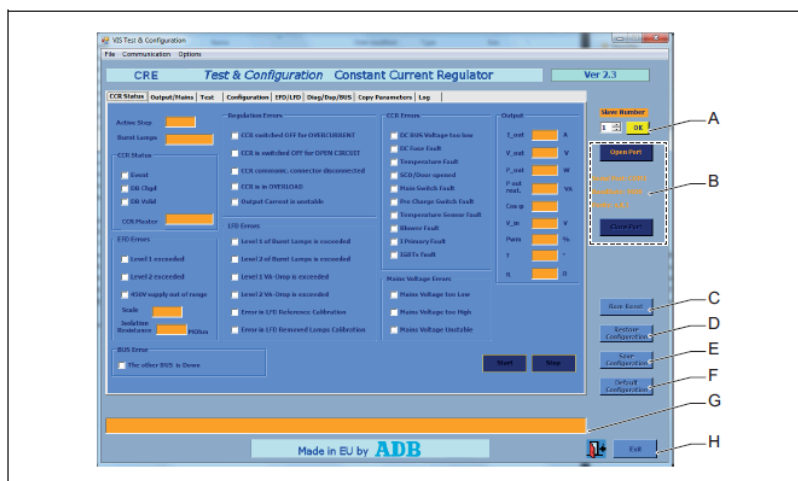

	Description	
A	Slave	To select the slave number of the equipment you want to connect to
B	Connection	To open and close the port to the selected slave number
C	Rem Reset	To reset the alarm. See also Alarms
D	Restore configuration	To restore a saved configuration from the PC to the equipment
E	Save configuration	To make the values sent to the equipment active on eeprom The values you send to the equipment are not active on the eeprom
F	Default configuration	To return to the factory default configuration
G	Message bar	Shows communication messages and error messages about the software configuration tool
H	Exit	To exit the configuration software tool

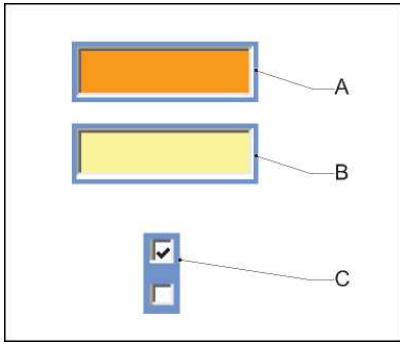

You can adjust the values in the yellow areas (A).
You cannot adjust values in the orange areas (B).
White selection boxes: if the box is marked, the item applies (C).

4.1.1 Screens

- CCR Status screen. See [CCR status screen](#)
- Output/Mains screen. See [Output/Mains screen](#)
- Test screen. See [Test screen](#)
- Configuration screen. See [Configuration screen](#)
- EFD/LFD screen. See [EFD/LFD screen](#)
- Diag/Dsp/BUS screen. See [Diag/Dsp/BUS screen](#)
- Copy Parameters screen. See [Copy Parameters screen](#)
- Log screen. See [Log screen](#)
- Test JBus screen. See [Test JBus screen](#)

4.2 CCR status screen

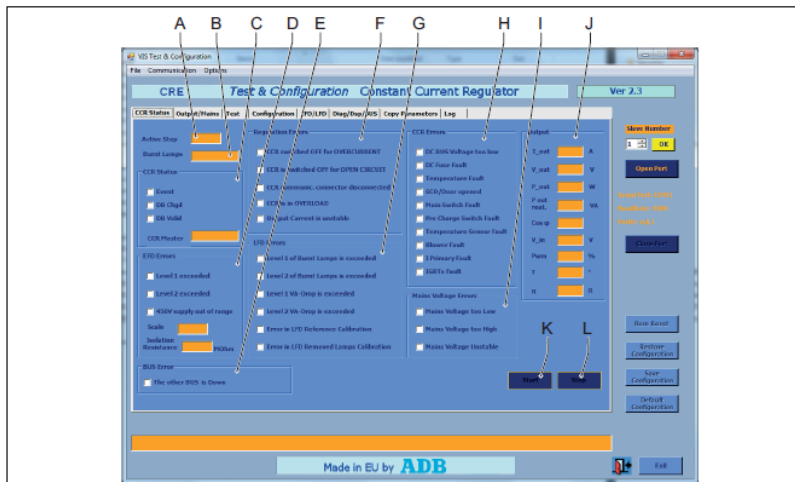

Description		
A	Active step	Shows the active brightness step of the selected equipment
B	Burnt lamps	Shows the number of burnt lamps in the series circuit
C	CCR Status	See CCR Status
D	EFD Errors	See EFD Errors
E	Bus Error	Only applies to a double J-Bus or Ethernet connection

Description		
F	LFD Errors	See LFD Errors
G	Regulation Errors	See Regulation Errors
H	CCR Errors	See CCR Errors
I	Mains Voltage Errors	See Mains Voltage Errors
J	Output	See Output
K	Start	To show the parameters of the selected slave equipment
L	Stop	To stop to show the parameters of the slave equipment

4.2.1 CCR Status

Item	Description
Event	An error event occurred
DB Chgd	A change was made to the database
DB Valid	The data in the database is up to date
CCR Master	<ul style="list-style-type: none"> LOCAL SELECTOR: the master is in LOCAL mode PC: the RS232 port of the master is active BUS A. The J-BUS is active and the master is in REMOTE mode

4.2.2 EFD Errors

	Possible cause	Alarm type
Level 1 exceeded	The resistance to earth is less than level 1 (20 MOhm default value)	The red light on the equipment goes on
Level 2 exceeded	The resistance to earth is less than level 2 (2 MOhm default value)	
450V supply out of range	The 450 V EFD test voltage is missing	
Scale	Shows 0 for a 20 pA EFD scale and 1 for a 200 pA EFD scale	
Isolation resistance	Shows the isolation resistance value (0 to 500 MOhm)	

4.2.3 LFD Errors

	Possible cause	Alarm type
Level 1 of Burnt Lamps is exceeded	Minimum 3 broken lamps	The red light on the equipment goes on
Level 2 of Burnt Lamps is exceeded	Minimum 5 broken lamps	
Level 1 VA-Drop is exceeded	The output power goes below a preset level	
Level 2 VA-Drop is exceeded	The output power goes below a preset level	
Error in LFD Reference Calibration	The LFD reference calibration is not done or is not successful	
Error in LFD Removed Lamps Calibration	The LFD removed lamps calibration is not done or is not successful	

4.2.4 Regulation Errors

	Possible cause	Alarm type
CCR switched OFF for OVERCURRENT	<ul style="list-style-type: none"> The output current is more than $I_{max} + 5\%$ for minimum 4s The output current is more than $I_{max} + 20\%$ for minimum 0.4s 	<ul style="list-style-type: none"> The equipment automatically switches OFF Restart the equipment only after you have found the cause of the alarm
CCR switched OFF for OPEN CIRCUIT	The output circuit is interrupted. Connect the cable correctly before you restart the equipment	
Measure board connector disconnected	<p>There is no communication between the CPU PCB and the measure PCB</p> <p>Possible root causes:</p> <ul style="list-style-type: none"> The optical cable is disconnected The power supply cable is disconnected Malfunction of the measure PCB 	
CCR is in OVERLOAD	The load of the equipment is too high	
Output current is unstable	<p>The output current fluctuates or could not reach the requested value</p> <p>Possible root causes:</p> <ul style="list-style-type: none"> Load switching (E.g. Aglas, Brite) To much load on the series circuit 	

4.2.5 CCR Errors

	Possible cause	Alarm type
DC BUS Voltage too low	<p>Only for a three-phase equipment. The voltage on the DC bus does not reach the nominal value</p> <p>Possible root causes:</p> <ul style="list-style-type: none"> Malfunction of the IGBT The wiring is not connected properly 	<ul style="list-style-type: none"> The equipment automatically switches OFF Restart the equipment only after you have found the cause of the alarm
Temperature Fault	The temperature of the heat sink is too high	
SCO/Door opened	A front, rear and/or field connection panel is open	The red light on the equipment goes on
Main Contactor Fault	<p>The main contactor does not switch on when the microprocessor gives an 'on' command</p> <p>Possible root causes:</p> <ul style="list-style-type: none"> Malfunction of the main contactor Malfunction of the feedback of the contactor A faulty connection on the power supply PCB 	
Pre-Charge Contactor Fault	<p>The precharge contactor does not go on when the microprocessor gives an 'on' command</p> <p>Possible root causes:</p> <ul style="list-style-type: none"> Malfunction of the main contactor Malfunction of the feedback of the contactor A faulty connection on the power supply PCB 	

	Possible cause	Alarm type
Temperature Sensor Fault	There is fault in the temperature measurement circuit	<ul style="list-style-type: none"> The equipment automatically switches OFF Restart the equipment only after you have found the cause of the alarm
Blower Fault	One or more fans do not operate correctly	
I Primary Fault	There is a problem with the current after the IGBT	
IGBT Fault	The IGBT test did not succeed after the 'ON step request' Possible root causes: <ul style="list-style-type: none"> Malfunction of the IGBT. A faulty wiring between the CPU PCB and the IGBT PCB Malfunction of the IGBT PCB 	

4.2.6 Mains Voltage Errors

	Possible cause	Alarm type
Mains Voltage too Low	The input voltage is too low. This can lead to an over current situation	<ul style="list-style-type: none"> The equipment automatically switches OFF Restart the equipment only after you have found the cause of the alarm
Mains Voltage too high	The input voltage is too high	
Mains Voltage unstable	The input voltage is not stable	The red light on the equipment goes on

4.2.7 Output

Item	Description
I_out	Shows the output current
V_out	Shows the output voltage
P_out	Shows the output power
V_in	Shows the input voltage
Pwm	Shows the PWM

4.3 Output/Mains screen

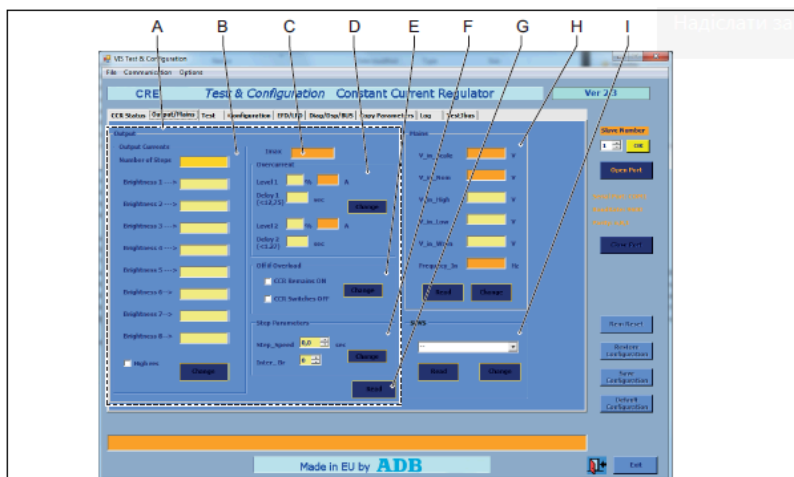

Description		
A	Output screen part	See items B to F
B	Output currents	See Off if overload
C	I _{max}	Shows the maximum output current
D	Overcurrent	See Overcurrent
E	Off if overload	See Off if overload
F	Step parameters	See Step Parameters
G	Read	To read the actual Output parameters from the selected equipment
H	Mains	See Mains
I	SHVS	Not used

4.3.1 Output currents

Item	Description
Number of Steps	To select the number of brightness steps
Brightness 1 to 8	To adjust the current for each brightness step, accurate up to 25 mA
Change	To activate the values and to send them to the equipment



Note

When you select less than 8 brightness steps, the steps higher than the highest step automatically get the current of the highest brightness step.

Example: When you select 4 brightness steps and you select 4.750 A for brightness step 4, brightness steps 5 to 8 are disabled and get 4.750 A current assigned automatically.

4.3.2 Off if overload

Item	Description
CCR Remains ON	To make sure that the equipment remains ON when the equipment is in overload state and the alarm comes up
CCR Switches OFF	To make sure that the equipment switches OFF when the equipment is in overload state and the alarm comes on
Change	To activate the values and to send them to the equipment

4.3.3 Overcurrent

Item	Description
Level 1 and Level 2	To set the percentage of the maximum of the two thresholds for overcurrent. The screen part also shows the actual current threshold values
Delay 1 and 2	To set the delay before the overcurrent alarm comes on, in s
Change	To activate the values and to send them to the equipment

4.3.4 Step Parameters

Item	Description
Step_Speed	To set the time that the equipment takes to change from one brightness step to another, in seconds (0 to 125 s)
Inter_Br	To define an intermediate brightness between steps
Change	To activate the values and to send them to the equipment

4.3.5 Mains

Item	Description
V_in_Scale	Shows the scale used to calculate the nominal voltage
V_in_Nom	Shows the nominal supply voltage
V_in_High	To adjust the supply voltage threshold above which the equipment restarts when switched OFF due to too low supply voltage
V_in_Low	To adjust the supply voltage threshold below which the equipment sounds an alarm and switches OFF
V_in_Warn	To adjust the voltage threshold above which the equipment sounds an alarm
Frequency_In	Shows the supply voltage frequency
Change	To activate the values and to send them to the equipment
Read	To read the actual Mains parameters from the selected equipment

4.4 Test screen

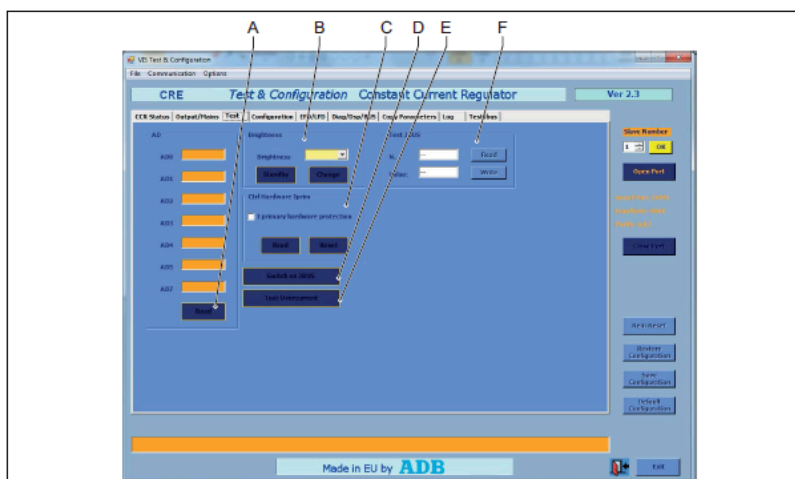

		Description
A	Read	To read the actual Analogue Data parameters (AD0 to AD7) from the selected equipment
B	Brightness	See Brightness
C	Ctrl Hardware Iprim	See Ctrl Hardware Iprim
D	Switch on JBUS	To enable the J-Bus serial port an to disable the RS232 serial port
E	Test Overcurrent	To start the overcurrent alarm test
F	Test JBUS	See Test JBUS

4.4.1 Brightness

Item	Description
Brightness	To select the step
Standby	To set the selected equipment to stand-by
Change	To activate the values and to send them to the equipment

4.4.2 Ctrl Hardware Iprim

Item	Description
I primary hardware protection	Shows if the primary current hardware protection is released. This is a read-only parameter
Reset	To reset the primary current hardware protection
Read	To read the actual primary current protection parameter from the selected equipment

4.4.3 Test JBUS

Item	Description
N.	To select the data line
Value	To select the test data value
Read	To read the actual JBUS parameters from the selected data line
Write	To send the selected test data to the selected data line

4.5 Configuration screen

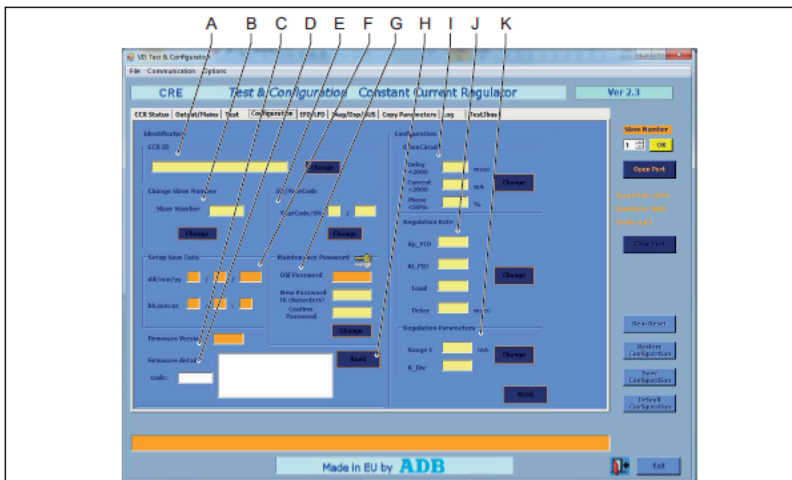

	Description
A CCR ID	See CCR ID
B Change Slave Number	See Change Slave Number
C Firmware version	Shows the firmware version of the selected equipment
D Firmware details	Shows a description on the firmware version of the selected equipment

Description	
E	SN/YearCode See SN/YearCode
F	Setup Save Date Shows the date and time of the latest save of the data of the selected equipment. The date and time are generated from the PC that is connected to the equipment
G	Maintenance Password See Maintenance Password
H	Read To read the actual configuration parameters from the selected data line
I	Open Circuit Do not use these parameters. There is a risk of damage to the equipment. Only ADB SAFEGATE service engineers are allowed to use these parameters
J	Regulation Rate
K	Regulation Parameters

4.5.1 CCR ID

Item	Description
Blank field	To change the name of the field circuit that the equipment delivers power to. This name shows in the HMI
Change	To activate the value and to send it to the equipment

4.5.2 Change Slave Number

Item	Description
Slave Number	To adjust the slave number of the selected equipment
Change	To activate the value and to send it to the equipment

4.5.3 SN/YearCode

Item	Description
YearCode/SN	To change the production year and the serial number
Change	To activate the value and to send it to the equipment

4.5.4 Maintenance Password

Item	Description
Old Password	Shows the current maintenance password
New Password	To adjust the maintenance password
Confirm Password	Copy the adjusted maintenance password for confirmation
Change	To activate the value and to send it to the equipment

4.6 EFD/LFD screen

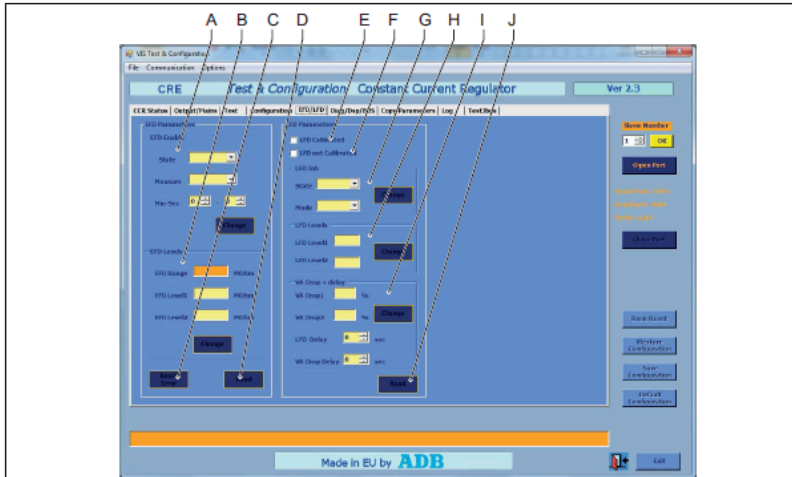

Description		
A	EFD Enable	See EFD Enable
B	EFD Levels	See EFD Levels
C	Reset error	To reset the EFD error
D	Read	To read the actual EFD parameters from the selected equipment
E	LFD Calibrated	Shows if the LFD is calibrated
F	LFD not Calibrated	Shows if the LFD is not calibrated
G	LFD Inh	See LFD Inh
H	LFD Levels	See LFD Levels
I	VA Drop + delay	See VA Drop + delay
J	Read	To read the actual LFD and VA Drop parameters from the selected equipment

4.6.1 EFD Enable

Item	Description
State	To select if the EFD measurement is enabled or disabled
Measure	If the EFD measurement is enabled, you can choose between these values: <ul style="list-style-type: none"> Interval: the interval between measurements is indicated in the Min-Sec field Continuous: the equipment measure continuously. The Min-Sec field is not active
Min-Sec	To set the time between measurement if the measurement is set as interval
Change	To activate the value and to send it to the equipment

4.6.2 EFD Levels

Item	Description
EFD Range	Shows the maximum earth leakage value the equipment can measure
EFD Level 1	To adjust the insulation resistance below which the equipment gives the EFD Level 1 alarm

Item	Description
EFD Level 2	To adjust the insulation resistance below which the equipment gives the EFD Level 2 alarm
Change	To activate the value and to send it to the equipment

4.6.3 LFD Inh

Item	Description
State	To select if the LFD is enabled or not
Mode	To choose between different LFD modes: <ul style="list-style-type: none"> Normal: both the LFD 1 and 2 Levels are active Degraded: only LFD 2 Level is active
Change	To activate the value and to send it to the equipment

4.6.4 LFD Levels

Item	Description
LFD Level 1 and Level 2	To adjust the threshold above which the equipment gives the LFD Level 1 and Level 2 alarm
Change	To activate the value and to send it to the equipment

4.6.5 VA Drop + delay

Item	Description
VA Drop1 and Drop2	To adjust the threshold above which the equipment gives the VA Drop 1 and Drop 2 alarm
LFD Delay	To adjust the minimum time span after the error before the equipment gives the LFD Level 1 or Level 2 alarm
VA Drop Delay	To adjust the minimum time span after the error before the equipment gives the VA Drop 1 or Drop 2 alarm
Change	To activate the value and to send it to the equipment

4.7 Diag/Dsp/BUS screen

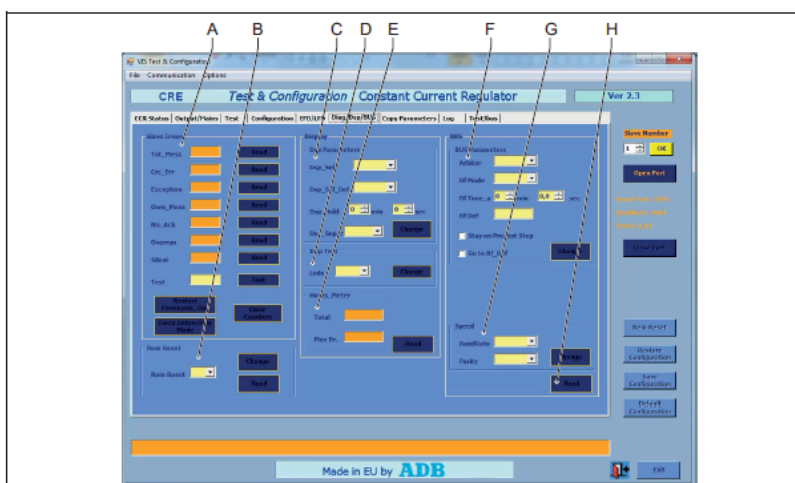

Description	
A Slave errors	See Slave Errors
B Rem Reset	See Rem Reset
C Dsp parameters	See Dsp Parameters
D Imp Test	See Imp Test
E Hours_Meter	See Hours_Meter
F Bus Parameters	<ul style="list-style-type: none"> ▪ Arbiter: To set the signal source for remote control. To set a priority for different systems. If you set this parameter to disabled, remote control is not possible. ▪ BF Mode: Use <i>normal</i> or <i>stop bar</i>. ▪ BF Time: The time after which the equipment starts to use the default settings. ▪ BF Def: To set default values that the equipment uses when the remote control (J-Bus) connection is down for longer than the time set in the menu. Leave this field blank or set a value from 1 to 8. ▪ Select either <i>Stay on Prevent</i> step or <i>Go to Bf-Def</i>.
G Speed	See Speed
H Read	To read the actual J-Bus parameter of the equipments



Note

To show the screen part with the bus parameters, select Options>Advanced.

4.7.1 Slave Errors

Item	Description
Read buttons	To read the actual slave error from the selected equipment
Tot_Mess	Shows the number of messages that the equipment received
Crc_Err	Shows the number of messages with checksum that the equipment received
Exception	Shows the number of messages with wrong commands that the equipment received
Own_Mess	Shows the number of messages that belong to the selected equipment
No_Ack	Shows the number of messages for which the equipment did not receive a reply
Overrun	Shows the number of messages with overrun that the equipment received
Silent	Shows the if the equipment replies to messages: <ul style="list-style-type: none"> ▪ 0: the equipment replies to messages ▪ 1: the equipment does not reply to messages
Test field	To test the communication. You can enter a number in the field to test
Test button	To test the communication with the value in the test field
Restart Communic.Opt	To set all counters to 0 and the silent value to 0
Force Listen Only Mode	To set the silent field to 1 and to force the equipment to reply to messages
Clear Counters	To set all counters to 0 but not to change the silent value

4.7.2 Rem Reset

Item	Description
Rem Reset	To enable or disable the Rem Reset button <ul style="list-style-type: none"> 1: the Rem Reset button is enabled 0: the Rem Reset button is disabled
Change	To activate the value and to send it to the equipment
Read	To read the actual Rem Reset parameter from the selected equipment

4.7.3 Dsp Parameters

Item	Description
Dsp_Sel	To select what the HMI shows optionally. You can choose from four parameters The HMI only shows the selected parameter <ul style="list-style-type: none"> LAMP: the number of broken lamps VA_Out: the VA output VA_Out%: the percentage of the VA output LMP_Test: to carry out a display test
Desp_Sel_Def	To select what the HMI shows optionally. You can choose from four parameters. The HMI shows the selected parameter, but only for the time indicated in the DSP_Hold field. <ul style="list-style-type: none"> LAMP: the number of broken lamps VA_Out: the VA output VA_Out%: the percentage of the VA output LMP_Test: to carry out a display test
Dsp_Hold	To adjust the time the HMI shows the optional parameter
Dec_Separ	To adjust the decimal separator for the UI (, or .)
Change	To activate the value and to send it to the equipment

4.7.4 Imp Test

Item	Description
LEDs	To carry out a test on the LEDs of the keyboard on the HMI. The LED adjacent to the DB9 connector comes on
Change	To activate the value and to send it to the equipment

4.7.5 Hours_Meter

Item	Description
Total	Shows the total time that the equipment is set to 'on' in h
Max Br.	Shows the time that the equipment operates at the maximum brightness step in h
Read	To read the actual hours parameters from the selected equipment

4.7.6 Rem Reset

Item	Description
Rem Reset	To enable or disable the Rem Reset button <ul style="list-style-type: none"> 1: the Rem Reset button is enabled 0: the Rem Reset button is disabled
Change	To activate the value and to send it to the equipment
Read	To read the actual Rem Reset parameter from the selected equipment

4.7.7 Speed

Item	Description
BaudRate	To adjust BaudRate of the J-Bus connection between the equipments
Parity	To adjust the parity of the J-Bus connection between the equipments
Change	To activate the value and to send it to the equipment. Do not change the speed parameters when you connect the equipment with the ethernet line

4.8 Copy Parameters screen

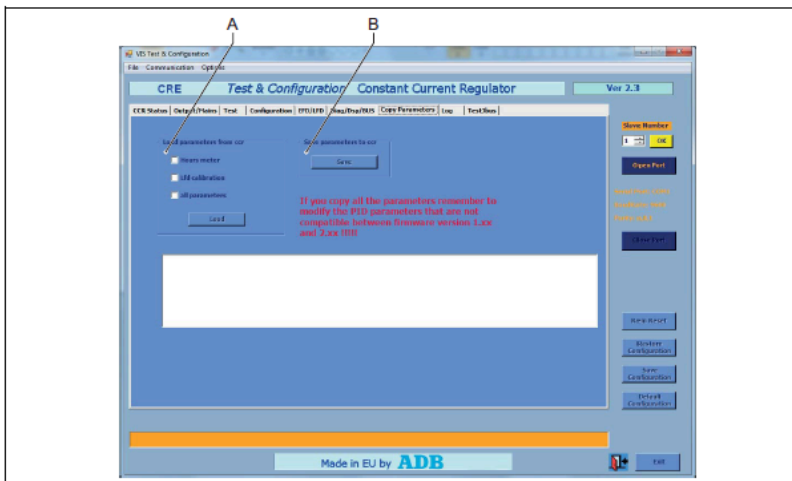

	Description
A Load parameters from ccr	See Load parameters from CCR
B Save	To save the parameters from the PC to the selected equipment

4.8.1 Load parameters from CCR

Item	Description
Hours meter	To select if you want to load/save the hours meter values of the equipment
Lfd calibration	To select if you want to load/save the LFD calibration parameters of the equipment
All parameters	To select if you want to load/save the all parameters of the equipment
Load	To load the selected parameters to the PCCCR

4.9 Log screen

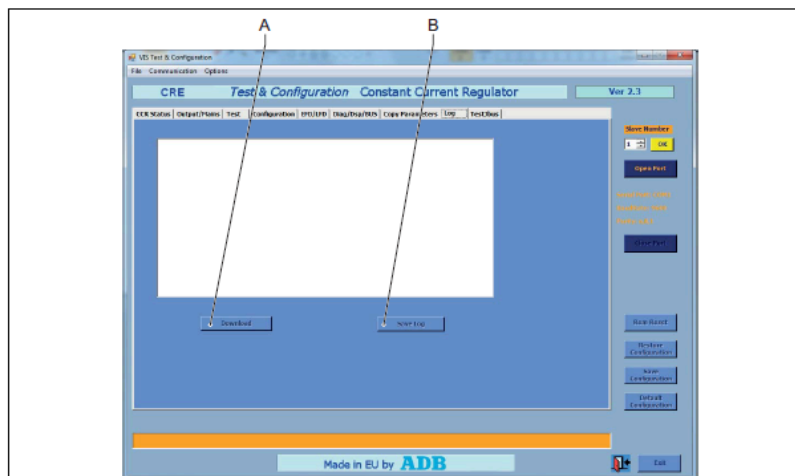

Description

A	Download	To show the history file of the selected equipment in the Log screen
B	Save Log	To save the log file to the PC

4.10 Test JBus screen

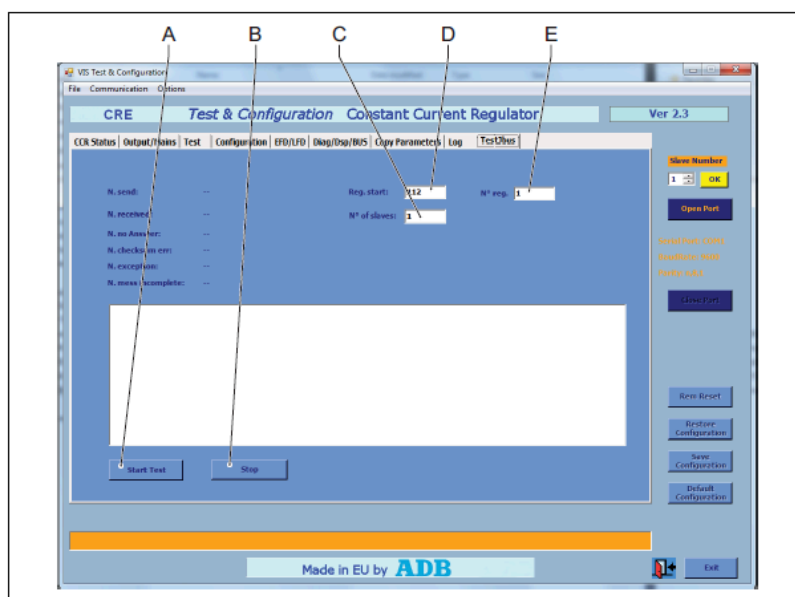

Description

A	Start Test	To start the test
B	Stop	To stop the test
C	No. of slaves	Shows the number of slaves
D	Reg. start	
E	No. of reg	

5.0 Circuit selector web interface (option CS)

Figure 21: Description of settings

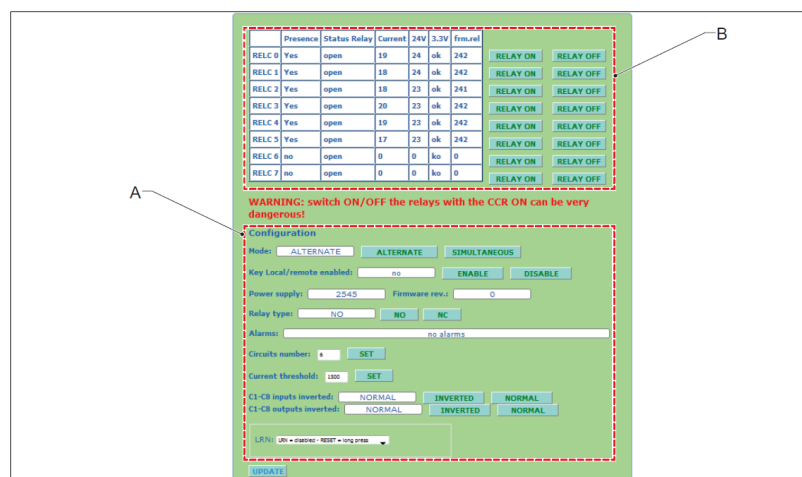

A Configuration settings

B Series circuits data

Table 8: Configuration settings

Setting	Description
Mode	Simultaneous: free circuit selection Alternate: only 1 circuit selection is possible (only for 2 way CS)
Key local/remote enabled	Set to: DISABLE
Circuits number	The number of used series circuits
Current threshold	Set to: 1500
C1-C8 inputs inverted	Set to: NORMAL
C1-C8 outputs inverted	Set to: NORMAL
LRN	Set to: LRN - disabled - REST = long press

Table 9: Series circuits data

Item	Description
Presence	YES for detected relays NO for undetected relays
3.3V	OK for all connected CS PCBs KO for all not connected CS PCBs
24V	Input voltage measured by the CS PCB
Status relay	To check the correction functioning of the relay, push the buttons RELAY ON and RELAY OFF
Current	The output current that the CS PCB measures
frm.rel	Firmware version on the interface PCB

6.0 Install and operate the configuration software tool

6.1 Install the configuration tool software

System requirements

- PC with Microsoft Windows 2000, XP operation system, or later
- At least 50 Mbytes free disk space
- 1 free serial communication (COM) port, or a virtual serial communication port over a USB bridge or a PCMCIA card
- PC user account with either administrator or power user rights

Move the WINCCR.exe file from the CD-ROM to the hard drive of the PC.

6.2 Start the configuration software tool

Activate the serial port, if applicable

1. On the HMI, push the **MENU** button to go to the Main menu.
2. Push the **SER/JBUS** button to go to the **SER/JBUS** screen.
3. Push the **SERIAL** button to activate the serial port.

Configure the ethernet port, if applicable

1. On the HMI, push the **MENU** button to go to the Main menu.
2. Push the **MORE** button to go to the **Mode** screen.
3. Push the **ETHERNET CONFIGURATION** button to configure the ethernet port.

Find the slave number of the equipment

1. On the HMI, push the **ESC** button to go to the Main menu.
2. Push the **OPTIONS** button to go to the **Options** menu.
3. Push the **SLVNUM** button to show the slave number.
4. Note the slave number. You will need it for reference later.

Connect the serial cable, if applicable

1. Switch **OFF** the equipment. See [Switch OFF the equipment](#).
2. Connect the extension cable to the dongle (A) and to the serial communication port of the PC (B).

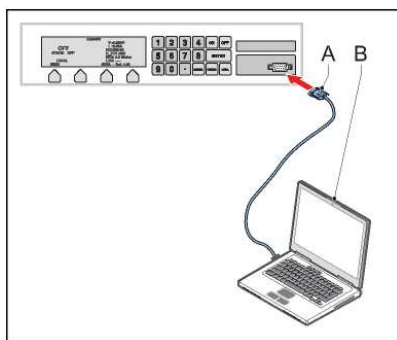

Connect ethernet cable, if applicable

1. Switch **OFF** the equipment. See [Switch OFF the equipment](#).
2. Connect the ethernet cable (B) to the equipment (A) and to the PC (C).

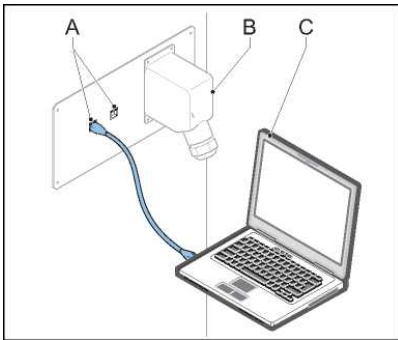

Configure the remote control ethernet connection

1. Make sure that the IP range of the PC is in the same range as the device.
2. Access the web control interface of the device.
3. From the **Network Settings** control panel, set the IP address, Netmask, and IP configuration to the values of the network that the Ethernet board uses.
4. From the **Serial Settings** control panel, make sure that the serial parameters have the values that follow:
 - Baud Rate: 9600
 - Data Bits: 8
 - Stop Bits: 1
 - Parity: None
5. From the **Operating Settings** control panel, make sure that the Port=01 parameters have the values that follow:
 - Operation mode: TCP Server Mode
 - TCP alive check time: 0
 - Inactivity time: 5000
 - Max connection: 1
6. Make sure the **Data Packing** parameters have the values that follow:
 - Delimiter 1: 0: Do not select Enable
 - Delimiter 2: 0: Do not select Enable
 - Force transmit: 10
7. Make sure the **TCP Server Mode** parameters have the values that follow:
 - Local TCP port: 502
 - Do not select Apply the above settings to all serial ports
8. From the **Serial Command Mode** control panel, make sure the serial parameters have the values that follow:
 - Trigger Setting: HW Trigger
 - SW Trigger Character: 2B 2B 2B

Start software

1. Switch the equipment **ON**.
2. Click the WINCCR.exe file in the directory where you installed the software. The configuration tool opens on the CCR Status screen.

Set up the serial port, if applicable

1. Select the menu **Communication**.
2. Select the applicable serial communication port (COM).



Note

The baud rate and parity settings for the communication between the PC and the equipment must be the same. For the dongle, the default baud rate is 9600 and the default parity setting is None.

3. Push the OK button to confirm the settings.
4. Push the Open Port button to open the selected serial port.
 - If the settings are correct, the yellow OK button is enabled and the bottom bar shows the message 'Port opened'.
 - If the settings are not correct, the bottom bar shows an error message.

Set up the Ethernet port if applicable

1. Select the menu Communication>Ethernet.
2. Select the applicable IP address and Port.
3. Push the **OK** button to confirm the settings.
4. Push the **Open Port** button to open the selected serial port.
 - If the settings are correct, the yellow OK button is enabled and the bottom bar shows the message 'Port opened'.
 - If the settings are not correct, the bottom bar shows an error message.

6.3 Monitor the data of an equipment

Select the equipment

1. Select the slave number of the equipment you want to monitor.
2. Push the **OK** button.

Start monitoring

1. Select the CCR status screen. See [CCR status screen](#).
2. Push the **Start** button. The screen shows the data of the selected equipment.

Stop monitoring

- Push the **Stop** button. The screen no longer shows the data of the selected equipment.

6.4 Stop the configuration software tool

1. Serial connection: Disconnect the extension cable from the dongle and the PC connector of the equipment.
2. Ethernet connection: Disconnect the ethernet cable from the PC and the equipment.

7.0 Commissioning

Main commissioning procedure

1. Do the first start-up. See [First start-up](#).
2. Calibrate the Lamp Fault Detection (LFD) module. See [Calibrate Lamp Fault Detection \(LFD\)](#).
3. Adjust the number of available brightness steps. See [Adjust number of used brightness steps](#).
4. Configure the remote control interface (option). See [Remote control configuration: multiwire \(option\)](#), [Remote control configuration: J-Bus \(option\)](#), or [Remote control configuration: ethernet \(option\)](#), depending on the hardware.

7.1 First start-up

The equipment stores the last request after a power cycle. This means that when the equipment is switched **ON**, it starts to produce the same output current that was valid before the equipment was switched **OFF**.

When you start up the equipment for the first time, the powering-down status is unknown. This procedure allows you to prevent the equipment from producing the output current at first start-up.

7.1.1 Procedure

1. Measure the input voltage. See [Measure input voltage](#) or [Measure input voltage on stackable cabinet](#).
2. Measure the output current in short circuit. See [Measure output current in short-circuit](#).
3. Measure the resistance and the insulation resistance of the series circuit. See [Measure insulation resistance of series circuit](#).
4. Measure the output current to the series circuit. See [Measure the output current to the series circuit](#).

7.1.2 Measure input voltage

Prepare

1. Make sure that the manual switch is in the **OFF** position. See [Switch OFF the power supply](#).
2. Remove the lower rear panel. See [Remove panels](#).
3. Set the manual switch to the **ON** position.
4. On the HMI, push the **Local** button. The screen now shows the state **LOCAL**.
5. Push the **OFF** button. The equipment goes to the mode **OFF**.

Measure

1. Measure the input voltage on the input terminals (A). Use a True RMS Multimeter.
2. Examine if the voltage is in accordance with:
 - The nameplate of the equipment.
 - Local regulations.



CAUTION

Excessive input voltage can damage the equipment.

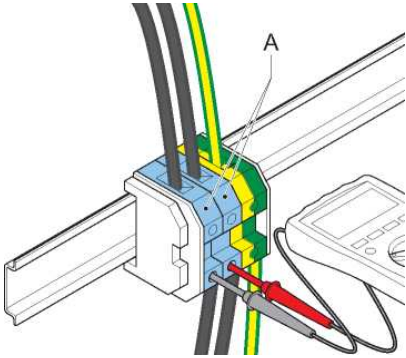

Finish

1. Switch off the power supply. See [Switch OFF the power supply](#).
2. Install the lower rear panel.

7.1.3 Measure input voltage on stackable cabinet

Prepare

1. Set the manual switch to the **ON** position.
2. On the HMI, push the **Local** button. The screen now shows the state **LOCAL**.
3. Push the **OFF** button. The equipment goes to the mode **OFF**.

Measure

1. Measure the input voltage on the pins 1 and 3 (A). Use a True RMS Multimeter.

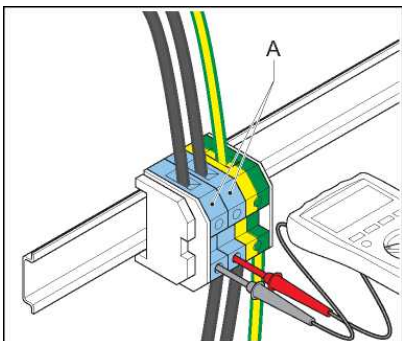

2. Examine if the voltage is in accordance with:
 - The nameplate of the equipment.
 - Local regulations.



CAUTION

An excessive input voltage can damage the equipment.

Finish

1. Switch off the power supply. See [Switch OFF the power supply](#).
2. Install the lower rear panel.

7.1.4 Measure output current in short-circuit

1. Make sure that all power to the equipment is **OFF**. See [Switch OFF the power supply](#).
2. Put the output in short-circuit. For SCB, see [Put SCB in short-circuit](#). For SCO, see [Put SCO in short circuit](#).
3. Measure the output current in short-circuit. See [Measure the output current in short circuit](#).
4. Make sure that all power to the equipment is **OFF**. See [Switch OFF the power supply](#).
5. If you use an SCB: Remove the separate piece of cable and connect the series circuit cables. See [Put SCB in short-circuit](#).
6. If you use an SCO: set the SCO to mode A. See [Operation mode](#).

7.1.5 Put SCB in short-circuit

Strip cables

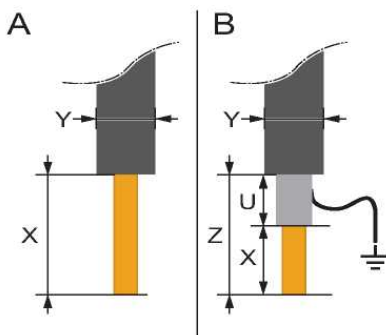

Strip a separate piece of series circuit cable at both ends.

- A: unscreened cables
 - X: 16 mm
 - \varnothing Y: less than or equal to 18 mm
- B: unscreened cables
 - X: 16 mm
 - \varnothing Y: less than or equal to 18 mm
 - U: 11 mm
 - Z: 77 mm

Remove the box panel of the SCB

1. Loosen the screws (A).
2. Remove the box panel (B).

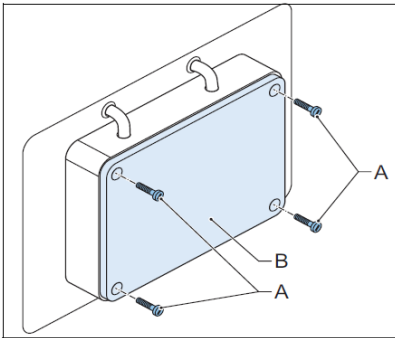

Short circuit SCB with separate piece of output cable

1. Disconnect the series circuit cables.
2. With the separate piece of output cable (B), short-circuit the output terminals (A).
3. Install the box panel.

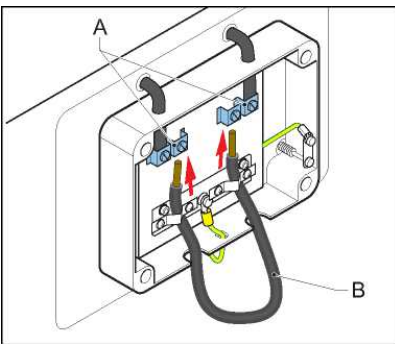

7.1.6 Put SCO in short circuit

Set the SCO to mode C. See [Operation mode](#)

7.1.7 Measure the output current in short circuit

Connect AC True RMS multimeter (SCB)

- Connect the current clamp of an AC True RMS multimeter (B) to the short-circuited cable (A).

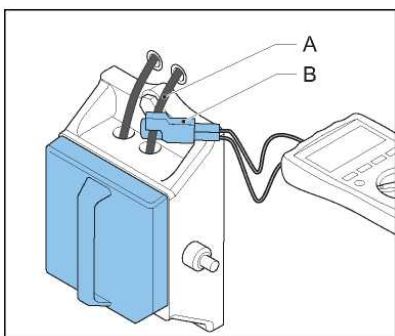

Measure output current

1. Switch **ON** the equipment and set it to **LOCAL** mode. See [Operation](#).
2. Select the step 6.6 A.
3. Read the output current value from the AC True RMS Multimeter.
4. Repeat the previous steps and examine the output current value for each brightness step. Check each brightness step separately from the highest to the lowest level.

7.1.8 Test CS in short-circuit (option CS)

Test the CS to make sure that the equipment produces the correct output current.

Prepare

1. Make sure that all power to the equipment is **OFF**. See [Switch OFF the equipment](#).
2. Remove the front panel and the CS cabinet panel. See [Remove panels](#).
3. Remove the output cable.

Strip cable

1. Strip a separate piece of output cable:
 - a. unscreened cables
 - X: 16 mm
 - \emptyset Y: less than or equal to 7 mm
 - \emptyset Z: less than or equal to 12 mm
 - b. screened cables
 - X: 14 mm
 - \emptyset Y: less than or equal to 14 mm
 - Z: less than or equal to 50 mm

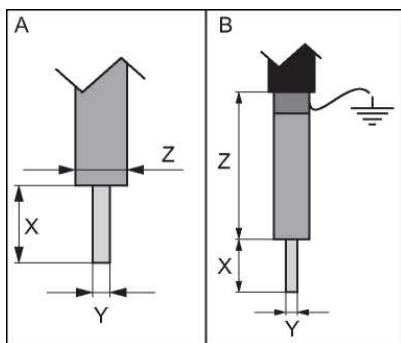

Short-circuit

With the separate piece of output cable, short-circuit the series circuit terminals (A).



Note

The illustration shows an equipment with connections to two series circuits, both in short-circuit. The procedure for more or less series circuits is similar.

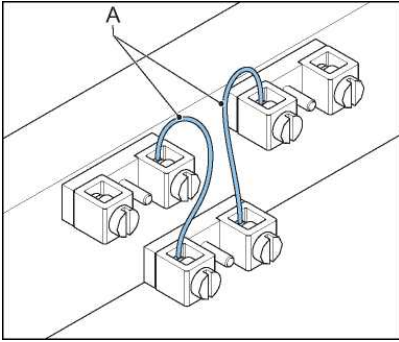

Connect AC True RMS multimeter

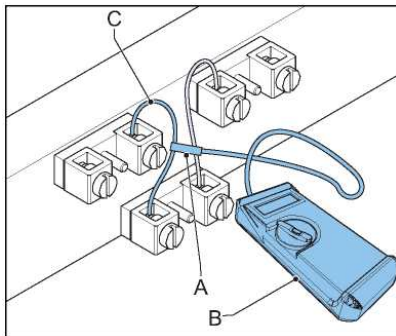

Connect an AC current clamp (A) and a True RMS multimeter (B) to the first short-circuited cable (C).

Activate Circuit 1

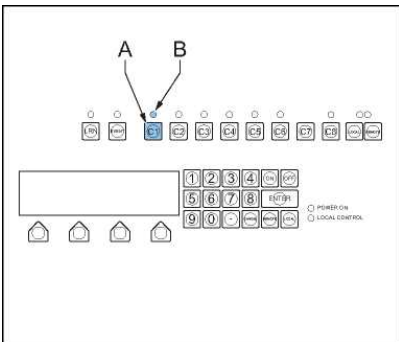

1. Switch ON the equipment. See [Operation](#).
2. Push the **C1** button (A) to select **Circuit 1**. The indicator for circuit 1 (B) goes on.

Measure

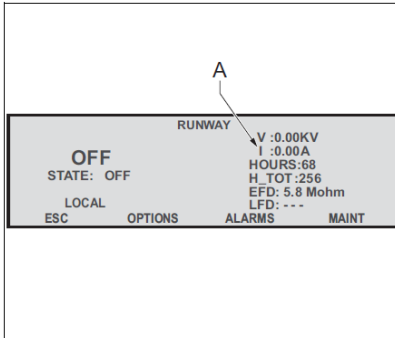

1. Adjust the brightness step until the HMI shows 6.6 A for True RMS output current (A). See [Select brightness step](#).
2. If the output current on the AC True RMS multimeter does not reach 6.6 A, change the series circuit configuration before you proceed.
3. Repeat the previous steps and examine the output current value for each step. Go through all steps separately from the highest to the lowest level.

Repeat

1. Make sure that all power to the equipment is **OFF**. See [Switch OFF the equipment](#).
2. Install the AC True RMS multimeter on the next circuit.
3. Activate the next circuit.
4. Measure the output current for the next circuit.
5. Repeat the previous steps for all circuits.

Repeat

1. Make sure that all power to the equipment is **OFF**. See [Switch OFF the equipment](#).
2. Install the front panel and the CS cabinet panel.

7.1.9 Measure output current series circuit (option CS)

The procedure applies to simultaneous circuit selectors. For alternate circuit selectors, measure each circuit separately.

Prepare

1. Switch ON the equipment. See [Operation](#).
2. Push the **C1** button (A) to select **Circuit 1**. The indicator for circuit 1 (B) goes on.
3. Repeat the previous step again and select all circuits.

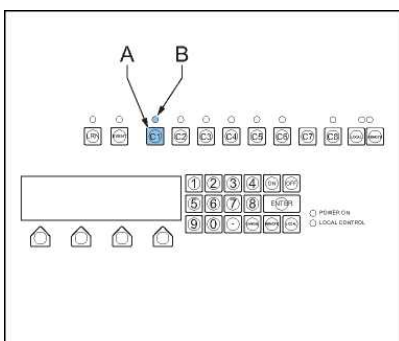

Measure

1. Adjust the brightness step until the HMI shows 6.6 A for True RMS output current (A). See [Select brightness step](#).
2. If the output current does not reach 6.6 A, change the series circuit configuration before you proceed.
3. Examine if all lights to the respective circuits have a similar current level. Go to the runway area to make a visual inspection.

Finish

1. Disable each circuit one by one menu (the indicators must be OFF). After you disable a circuit, check that the lights in that circuit go **OFF**.
2. Set the equipment to **OFF**. See [Switch OFF the equipment](#).

7.1.10 Measure resistance and the insulation resistance of series circuit

1. Prepare the series circuit. For SCB, see [Prepare with SCB](#). For SCO, see [Prepare with SCO](#).
2. Measure the resistance of the series circuit. See [Measure resistance of series circuit](#).
3. Measure the insulation resistance of the series circuit. See [Measure insulation resistance of series circuit](#).
4. Calculate minimum insulation resistance of series circuit. See [Calculate minimum insulation resistance of series circuit](#).
5. Calculate resistance of series circuit See [Calculate resistance of series circuit](#).
6. Complete the activities. See [Complete the measurement](#).

7.1.11 Prepare with SCB

Set power to OFF

- Make sure that all power to the equipment is **OFF**. See [Switch OFF the power supply](#).

Remove the box panel

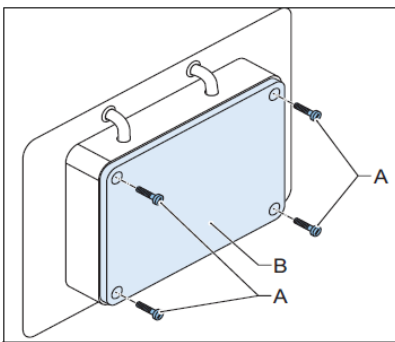

1. Loosen the screws (A).
2. Remove the box panel (B).

Discharge the output terminals

1. Discharge the output terminals.
2. Completely remove the series circuit cables, also the shielding, if applicable.

7.1.12 Prepare with SCO

Set power to OFF

1. Make sure that all power to the equipment is **OFF**. See [Switch OFF the power supply](#).
2. Set the SCO to mode C. See [Operation mode](#). The output terminals are now discharged.

Remove cover

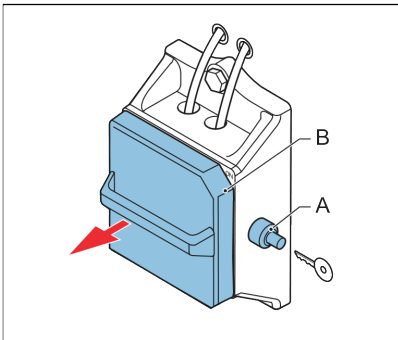

1. Open the lock (A).
2. Remove the cover (B). Use the handle.

Remove series circuit cables

- Completely remove the series circuit cables, also the shielding, if applicable.

7.1.13 Measure resistance of series circuit

Measure the resistance: measure on the ends of the series cable (A). Use a multimeter (B), in accordance with local regulations.

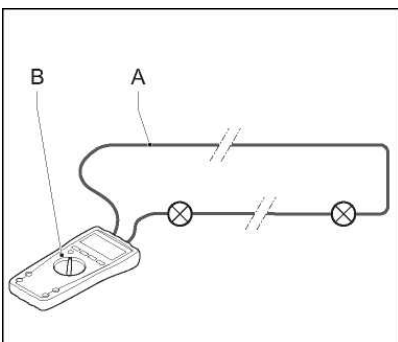

7.1.14 Measure insulation resistance of series circuit

1. Join the ends of the series circuit cables (C).
2. Measure the insulation resistance of the series circuit. Use the insulation tester (E). Megger 5000 V or 10000 V, in accordance with local regulations.
 - A: when the series circuit cable is not shielded
 - B: when the series circuit cable is shielded. Measure the earth on the shield (D).

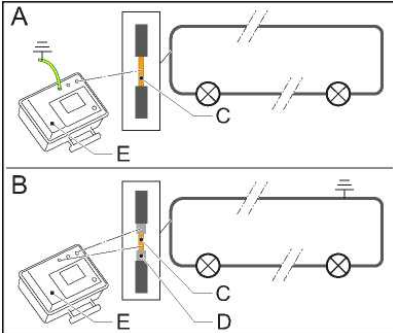

7.1.15 Calculate minimum insulation resistance of series circuit

Table 10: Theoretical insulation resistance for the series circuit

Item	Maximum insulation resistance current (standard: ICAO, part 5, § 3.9.4.7) [µA]
Series transformer	2
100 m of cable with standard number of connectors	1

Example: a runway center-line circuit with 133 light fixtures with a total length of the series circuit of 8 km.

- Allowed insulation resistance current for the transformers is $133 \times 2 = 266 \mu\text{A}$
- Allowed insulation resistance current the cable is $80 \times 1 = 80 \mu\text{A}$
- Total allowed insulation resistance current for this circuit is $266 \mu\text{A} + 80 \mu\text{A} = 346 \mu\text{A}$
- When you test with 5000 V, according to Ohms law, the minimum resistance is 14 MOhm.

7.1.16 Calculate resistance of series circuit

$$R_{\text{prim}} = \rho \times L/A + y \times 0.1212$$

Where:

- R_{prim} = resistance of the series circuit in Ohm
- $\rho = 18 \times 10^{-3} \text{ (Ohm} \times \text{mm}^2\text{)/m}$
- L = length of the circuit in m
- A = section of the cable in mm^2
- y = number of series transformers in the circuit

Example:

circuit length is 8000 m

cable section is 6 mm^2

number of series transformers is 122

Then $R_{\text{prim}} = (18 \times 10^{-3}) \times 8000/6 + 122 \times 0.1212 = 36.7 \text{ Ohm}$

7.1.17 Complete the measurement

1. Make sure that the measured and the calculated values match and that all the values are in accordance with all local safety regulations.

2. Connect the series circuit cables to the equipment.
3. Install the cover or the box panel.

7.1.18 Measure the output current to the series circuit

Prepare

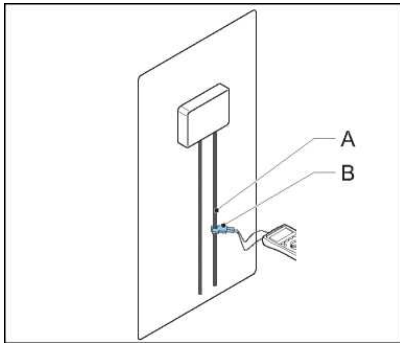

1. Make sure that the series circuit is measured and approved. See [Measure resistance and the insulation resistance of series circuit](#).
2. Make sure that all power to the equipment is **OFF**. See [Switch OFF the power supply](#).
3. Make sure that the series circuit is connected.
4. Connect an AC current clamp (B) to the series circuit cable (A).

Measure

1. Switch **ON** the equipment and set it to **LOCAL** mode. See [Operation](#).
2. Select the step 6.6 A.
3. If the output current does not reach 6.6 A, change the series circuit configuration before you proceed. This indicates that the equipment is too small for the load.
4. Compare the output current reading on the HMI with the reading on the True RMS Multimeter.
5. Examine if the output current readings are in accordance with local regulations. If not, do not continue.

Check brilliancy level

1. Examine if all light fittings have the same brilliancy level. Go to the runway area to make a visual inspection.
2. Examine all the brightness steps separately. Go through the whole procedure for each brightness step.

Finish

1. Wait for approximately 30 minutes and make sure that the equipment works correctly.
2. Make sure that all power to the equipment is **OFF**. See [Switch OFF the power supply](#).

7.2 Calibrate Lamp Fault Detection (LFD)

Follow this procedure to make sure that the equipment indicates the correct number of broken lamps. See [Input filter](#) for the accuracy of the LFD.



CAUTION

The LFD module does not work if the series circuit includes these types of lights:

- LED lights without the monitoring option
- PVO/PVL lights (guidance signs)
- WIGWAG (runway guard lights)

Make sure that all lamps in the series circuit operate

1. Make sure that the equipment is connected to the series circuit.
2. Switch **ON** the equipment and set it to **LOCAL** mode. See [Preliminary checks](#).
3. Set the equipment to the highest brightness step. See [Checks and measurements](#).
4. Examine if all light fittings light up. Go to the runway area to make a visual inspection.
5. Push the **OFF** button on the UI.

Select LFD calibration

1. On the HMI, push the **Options** button to go to the **Calibrate Lamp Fault Detection** menu.
2. Push the **LFD** button. The HMI prompts you to do the calibration.
3. Push the **Yes** button. The HMI prompts you regarding the number of burnt lamps (0 - 99).
4. Select '0', no broken lamps.
5. Wait until the equipment shows the Main screen. See [Display overview: Main screen](#)

Remove lamps

1. Make sure that all power to the equipment is **OFF**. See [Switch OFF the power supply](#).
2. Earth the series circuit
 - With the SCO. See [Use Series CutOut \(SCO\)](#)
 - With an earthing wire on the SCB
3. Remove the desired number of lamps in the field.



Note

Choose the number of lamps in function of the alarm level you use. By default, 8 to 10 lamps.

4. Switch **ON** the equipment and set it to **LOCAL** mode. See [Operation](#).

Set number of removed lamps

1. On the HMI, push the **Options** button to go to the **Options** menu.
2. Push the **LFD** button. The HMI prompts you to do the calibration.
3. Push the **Yes** button. The HMI prompts you regarding the number of burn lamps (0 - 99).
4. Enter the number of removed lamps.
5. Wait until the equipment shows the Main screen. See [Display overview: Main screen](#).

Examine the LFD measurement

1. Make sure that all power to the equipment is **OFF**. See [Switch OFF the power supply](#).
2. Connect a number of lamps, but not all.
3. Switch **ON** the equipment and set it to **LOCAL** mode. See [Operation](#).
4. Make sure that the number of lamps removed corresponds to the LFD reading on the main menu.
5. Make sure that all power to the equipment is **OFF**. See [Switch OFF the power supply](#).
6. Leave the equipment **OFF** for 10 seconds.
7. Repeat the previous steps and connect the rest of the lamps.

Set alarm level

- With the configuration software tool, set the LFD Level1 and LFD Level2 alarm levels. See [EFD/LFD screen](#).

7.3 Remote control configuration: multiwire (option)

Examine if the equipment is set to multiwire remote control

1. On the HMI, push the **MENU** button to go to the Main menu.
2. Push the **MAINT** button to go to the Maintenance menu. See [Maintenance menu](#).
3. Push the **MORE** button.
4. Push the → or ← buttons until the HMI shows the remote control mode.
5. Make sure that the remote control mode is 'MULTIWIRE'.
6. If necessary, adjust the remote control mode.

Examine or adjust the input and output signals function assigned to terminals

1. Push the → or ← buttons until the HMI shows the multiwire configuration.
2. Check and adjust the signals if necessary. See [Maintenance menu](#).



Note

For the standard multiwire configuration, see [Remote Control PCB](#).
You can only adjust the signals 6 to 15. The other signals are fixed.

7.4 Remote control configuration: J-Bus (option)

Configure the slave number

1. On the HMI, push the **MENU** button to go to the Main menu.
2. Push the **OPTIONS** button to go to the Options menu.
3. Push the **SLVNUM** button to set the slave number of the equipment.
4. Push the **SAVE** button to save the slave number to the equipment.

Examine and adjust the configuration, if necessary

1. On the HMI, push the **ESC** button a number of times until the UI shows the Main menu.
2. Push the **MAINT** button to go to the Maintenance menu. See [Maintenance menu](#).
3. Push the **MORE** button.
4. Push the → or ← buttons until the HMI shows the remote control mode.
5. Set the remote control mode to 'JBUS'.
6. Set the applicable J-Bus protocol. The default value is 'MCR2'.
7. Set the J-Bus mode to '485'.

7.5 Remote control configuration: ethernet (option)

Examine the remote control mode and adjust if necessary

1. On the HMI, push the **MENU** button to show the Main menu. See [Display overview: Main screen](#).
2. Push the **MAINT** button to go to the Maintenance menu. See [Maintenance menu](#).
3. Push the **MORE** button.
4. Push the → or ← buttons until the HMI shows the remote control mode.
5. Set the remote control mode to 'JBUS'.
6. Set the applicable J-Bus protocol. The default value is 'MCR2'.
7. Set the J-Bus mode to 'Ethernet'.

Examine the ethernet configuration and adjust if necessary

1. Push the → or ← buttons until the HMI shows the ethernet configuration.
2. Examine the parameters and adjust if necessary.
3. If you use a double ethernet connection, push the DOWN button until the HMI shows the ethernet configuration of the second ethernet connection.
4. Examine the parameters and adjust if necessary.

7.6 CS configuration (option CS)

Tools

- PC with ethernet connector
- RJ45 cable (ethernet cable)

Connect the PC to the interface PCB (PCB1702)

1. Switch OFF the equipment. See [Switch OFF the equipment](#).
2. Remove the front panel. See [Remove panels](#).
3. Connect the ethernet cable (A) to the PC (B) and the interface PCB (C).

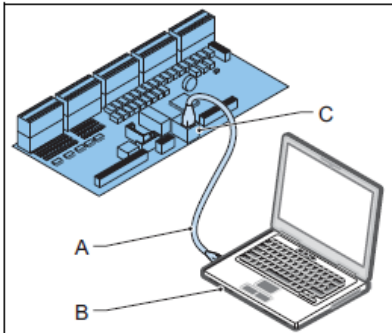
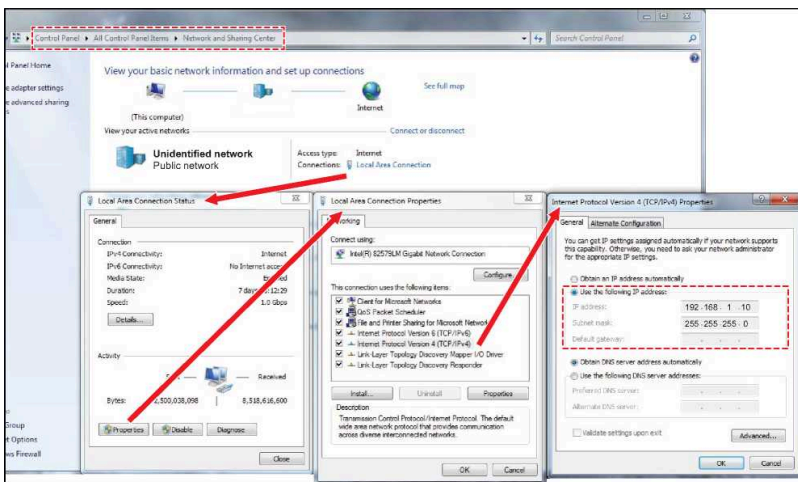

Figure 22: Select a 'useable IP address'



Examine the ethernet configuration and adjust if necessary

1. Simultaneously press button C2 on the HMI and switch **ON** the equipment. See [Operation](#).
 2. Wait until the LEDs on the HMI for local and remote will flash simultaneously. Now, you can configure the CS.
 3. Release the button C2 on the HMI. Now, you can configure the CS.
 4. On the PC, go to web address 192.168.1.22 to connect to the Circuit selector web-interface.
 5. Change parameters where necessary.
-



Note

Press the 'Update' button after a change.

6. Switch OFF the equipment. See [Switch OFF the equipment](#).
7. Disconnect the ethernet cable.
8. Install the front panel. See [Remove panels](#).

Configure the HMI

1. Switch ON the equipment. See [Operation](#).
 2. On the HMI, go to the maintenance menu.
 3. Push the **MORE** button.
 4. Push the → or ← buttons until the HMI shows the CSE mode screen.
 5. Push the **ON** button.
 6. Push the → or ← buttons until the HMI shows the multiwire configuration.
 7. Set the values to the list below:
 - J6.1: Circuit selector CCRON
 - J6.2: OVER CURRENT
 - J6.3: OPEN CIRCUIT
 - J6.5: Circuit selector 2
 - J6.7: EFD WARNING
 - J6.8: EFD ERROR
 - J7.1: HIGH TEMPERATURE ALARM
 - J7.2: Circuit selector 6
-



Note

The alarms OVER CURRENT and OPEN CIRCUIT are also used on the interface PCB to generate the error signal 'CCR FAULT'

8.0 Operation

8.1 Switch ON the equipment

When you switch **ON** the equipment, it starts to produce the same output current that was valid before the equipment was switched **OFF**.

To set a different output current, select another brightness step. See [Select brightness step](#). For more information on the produced output currents, see [Used brightness steps](#).

A prerequisite for this procedure is that the equipment is switched off.

1. Set the manual switch (A) to the **ON** position.
 - The equipment starts to produce the same output current that was valid before the equipment was switched **OFF**
 - The HMI lights up
 - The equipment starts in the same mode as it was stopped: Local or Remote mode



WARNING

High voltage can be present on the system.

2. If the UI shows that the equipment is in the state **OFF**, push the **ON** button. The HMI shows the state **ON**.
3. To switch between Local and Remote mode, see [Switch between local and remote mode](#).

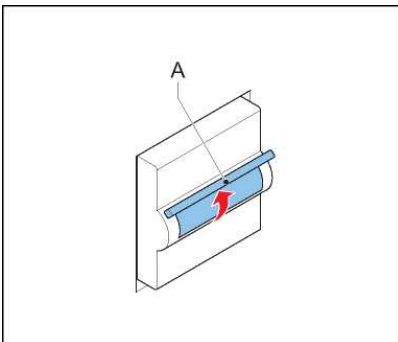

8.2 Switch OFF the equipment

1. On the HMI, push the **Local** button. The screen now shows the state **LOCAL**.
2. Push the **OFF** button. The equipment goes to the mode **OFF**.
3. Switch **OFF** the power supply. See [Switch OFF the power supply](#).

8.3 Switch OFF the power supply

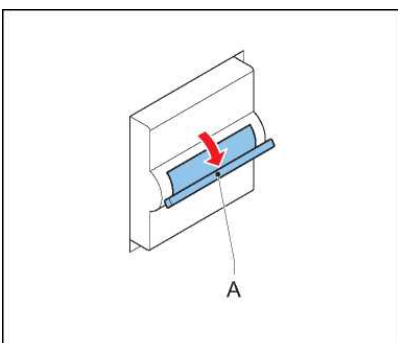

1. Set the manual switch (A) to the **OFF** position.
2. Open the main switch on the main distribution board.
3. Disconnect the equipment from the series circuit.

8.4 Switch between local and remote mode

To control the equipment through the HMI, switch to the local mode.

To control the equipment with the remote control system, switch to the remote mode.

1. For Local mode, push the **LOCAL** button on the HMI. The HMI now shows the mode **LOCAL**.



Note

The keypad keys on the HMI only operate when the equipment is in **Local** mode.

2. For Remote mode, push the **REMOTE** button on the HMI. The UI now shows the mode **REMOTE**. You can change the brightness step with the remote control device.

8.5 Select brightness step

1. Make sure that the equipment is powered **ON**, is in the **ON** state and in **Local** mode. See [Operation](#).
2. To select a brightness step, push the corresponding number on the keypad. The equipment immediately starts to produce the chosen brightness.

8.6 Adjust number of used brightness steps

1. Use the configuration software tool. See [Output/Mains screen](#). For information on the used brightness steps, see [Used brightness steps](#).
2. Examine all brightness steps one by one. See [Select brightness step](#). Examine if all light fittings have the same brilliancy level. Go to the runway area to make a visual inspection.

8.7 Alarms

The HMI only shows information about errors that the equipment can detect. The equipment does not detect all possible errors. You have to observe if the equipment operates correctly.

Local mode

An alarm occurs, the equipment switches **OFF** automatically.

- If you need to switch off the power supply to remove the cause of the alarm: The equipment starts to produce the same output current that was valid before the equipment was switched **OFF**.
- If you do not need to switch off the power supply to remove the cause of the alarm: The equipment remains in the state **OFF**. Only after you reset the alarm and push the **ON** button, does the equipment start to produce the same output current that was valid before the equipment was switched **OFF**.

Remote mode

An alarm occurs, the equipment switches **OFF** automatically.

- If you need to switch off the power supply to remove the cause of the alarm: The equipment starts at the actual multiwire/J-Bus command.
- If you do not need to switch off the power supply to remove the cause of the alarm: After you reset the alarm, the equipment automatically goes to the actual multiwire command.

Reset an alarm

1. If the HMI does not show the alarm, push the **Menu** button to go to the Main Menu.
2. To go to the Alarms menu push the **Alarms** button.
3. To reset the alarm push the **Reset** button.

Clear the error list

1. On the HMI, push the **Menu** button to go to the Main Menu.
2. Push the **Alarms** button to go to the Alarms menu.
3. Push the **Clear alarms** button. The equipment clears the error list.

8.8 Use Series CutOut (SCO)

8.8.1 Operation mode



WARNING

Always wear protective gloves and shoes when working with the equipment or series circuit.

The SCO has three operation modes:

Description	Mode A	Mode B	Mode C
Purpose	Normal operation Equipment delivers current to the connected series circuit	Maintenance operation Equipment or series circuit can be serviced safely	Measurement possible The series circuit insulation relative to ground can be measured
Diagram			
Cover placement¹			
Handle position	Horizontal	Turned 90 degrees counter clockwise from position A	Turned 90 degrees clockwise from position A
Series circuit	Connected to the equipment	Shorted and grounded	Disconnected from equipment, shorted and connected to measurement terminal
Equipment	Delivers current to the series circuit	Shorted and grounded	Shorted and grounded
Microswitch²	Activated. Equipment is ON	Not activated. Equipment is OFF	Activated. Equipment is ON

¹Only the three positions shown can be used. In another position, the cover fits correctly.

²When the cover is closed, the micro switch is activated. When the cover is open, the microcircuit is deactivated and the equipment shuts down.

8.8.2 Adjust operation mode

Remove the cover

1. Open the lock (A).
2. Remove the cover (B). Use the handle.

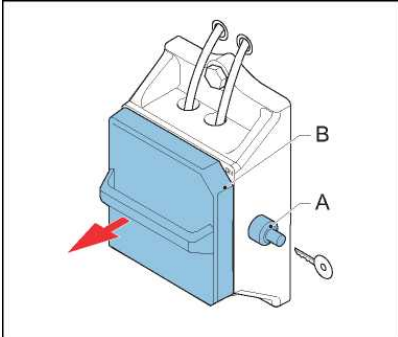

Set operation mode

1. Install the cover (B). See the cover placement in [Operation mode](#).
2. Close the lock (A).

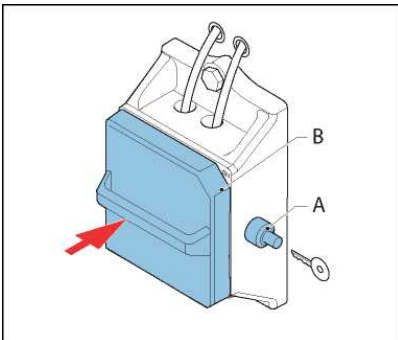

8.9 Operation mode

A series circuit with non-linear loads can be unstable. If the system is unstable, follow the procedure below.



Note

The equipment automatically detects if the inductive mode is required. The alarm message '**DC BUS VOLTAGE TOO HIGH**' means that the series circuit is unstable.

1. On the HMI, push the **MENU** button to go to the Main menu.
2. Push the **OPTIONS** button to go to the Options menu.
3. Push the **MODE** button to go to the Mode menu.
4. Select the applicable mode: **Normal** is the factory default. **Inductive** is for cases where the current regulation is under the influence of inductive load and becomes unstable. The HMI now shows the Main screen.

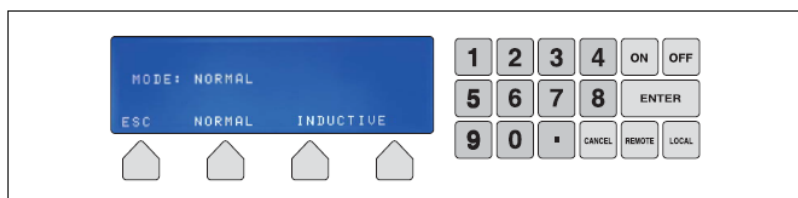

Note

The equipment has these limitations in inductive mode:

- The power is limited to 85%
- The LFD measurement is not active
- In normal mode the equipment limits all current peaks higher than 7 A in less than 10 ms, in inductive mode the current peak can reach 9 A
- The output waveform is not a perfect sinusoidal wave.

9.0 Troubleshooting



WARNING

Do not troubleshoot unless you have read and understood all the information in the chapter [Safety](#) and you are qualified to work on high-voltage systems.

- Set the equipment to **Local** mode
- Set the equipment to the brightness step **OFF** before you examine the series circuit
- Turn **Off** the main switch of the equipment

If you do not follow the steps above, an increase of the power input can start an on cycling and restart the equipment. This results in a possible lethal output voltage.

9.1 Preliminary checks

Before you do any adjustments on the equipment, check:

- the alarm and back-indication signals on the display and/or remote control
- if the power supply to the equipment is within the acceptance limit
- if the fused input switches and auxiliary fuses are operational
- if the input fuses and auxiliary fuses work normally
- if all connectors are correctly in place
- that no components show burned marks.
- if the input circuit breaker is in the 'open' position
- wires are not interrupted or damaged.

9.2 Troubleshooting guide



Note

For a list of errors, see [CCR status screen](#).

9.2.1 Fault: Equipment does not turn ON

Table 11: Equipment does not turn ON

Problem	Possible cause	Possible solution
No display indications	A problem with the power supply on the diode bridge PCB	<ul style="list-style-type: none"> ▪ Examine the transformer on the diode bridge ▪ If necessary, replace the IGBT power bridge that contains the diode bridge PCB <p>See Diode bridge + sensing PCB (EPS476 / EPS507) replacement, small and stackable cabinet</p>
	The main switch is damaged	Replace the main switch. See Manual switch replacement
	The input line filter is damaged	Replace the line filter. See Line filter replacement
	The main contactor is damaged	Replace the main contactor. See Main contactor replacement, small cabinet or Main contactor replacement, big cabinet

Table 11: Equipment does not turn ON

Problem	Possible cause	Possible solution
		Replace the power supply PCB. See Power supply PCB (EPS480) replacement
		Replace the CPU PCB. See CPU PCB (EPS479) replacement

9.2.2 Fault: Equipment does not go to the ON state

Table 12: Equipment does not turn ON

Problem	Possible cause	Possible solution
Local mode: <ul style="list-style-type: none"> The display shows an alarm The red lamp on top of the equipment goes on 	One of the panels is open	Close the panel <ul style="list-style-type: none"> Examine the fuses on power supply PCB Replace the fuses if necessary. See Fuses on the power supply PCB (EPS480) replacement
Remote mode: <ul style="list-style-type: none"> The red lamp on top of the equipment goes on 		<ul style="list-style-type: none"> Examine the CPU PCB Replace the CPU PCB if necessary See CPU PCB (EPS479) replacement
	The main contactor is enabled when the equipment is in the OFF state when there is no command from the CPU PCB. Or The main contactor is not enabled when there is a command from the CPU PCB	<ul style="list-style-type: none"> Examine the main contactor Replace the main contactor if necessary See Main contactor replacement, small cabinet or Main contactor replacement, big cabinet
		Examine the wiring connections <ul style="list-style-type: none"> Examine the CPU PCB Replace the CPU PCB if necessary See CPU PCB (EPS479) replacement
	One or more phases is not present	<ul style="list-style-type: none"> Examine the fuses on power supply PCB Replace the fuses if necessary See Fuses on the power supply PCB (EPS480) replacement
		<ul style="list-style-type: none"> Examine the external 400 VAC/24VAC transformer Replace the external transformer, if necessary
	One of the fuses for the phases is broken	<ul style="list-style-type: none"> Examine the main fuses Replace the broken fuse. See Main fuses replacement

9.2.3 Fault: Equipment turns ON but suddenly de-energizes

Table 13: Equipment turns ON but suddenly de-energizes

Problem	Possible cause	Solution (See)
After you press the ON button, record these problems: Local mode: <ul style="list-style-type: none"> The display shows an alarm The red lamp on top of the equipment goes on Remote mode: <ul style="list-style-type: none"> The red lamp on top of the equipment goes on 	The input AC line delivers less than 360 VAC	Examine the input VAC line <ul style="list-style-type: none"> Examine the external 400 VAC/24VAC transformer Replace the external transformer, if necessary
	Open circuit	Examine the connection of the high voltage cable to the field connection unit and to the power supply transformer <ul style="list-style-type: none"> Examine the output measure PCB. Replace the output measure PCB, if necessary. See Output measure PCB (EPS442) replacement
	Overcurrent	<ul style="list-style-type: none"> Examine the output measure PCB Replace the output measure PCB, if necessary. See Output measure PCB (EPS442) replacement
	A malfunction of the communication of the output measurement PCB	<ul style="list-style-type: none"> Examine the IGBTs If necessary, replace the IGBT power bridge that contains the IGBT. See IGBT replacement, stackable and small cabinet or IGBT replacement, big cabinet
	The current on the primary winding of the power supply transformer is too high	<ul style="list-style-type: none"> Examine the CPU PCB Replace the CPU PCB if necessary See CPU PCB (EPS479) replacement
		<ul style="list-style-type: none"> Examine the IGBT PCB If necessary, replace the IGBT power bridge that contains the IGBT PCB. See IGBT replacement, stackable and small cabinet or IGBT replacement, big cabinet

9.2.4 Fault: equipment does not produce requested output current

Table 14: Equipment does not produce the requested output current

Problem	Possible cause	Solution (See)
The red lamp on top of the equipment goes on	The equipment does not operate correctly	<ul style="list-style-type: none"> Examine the IGBT modules If necessary, replace the IGBT power bridge that contains the IGBT module See IGBT replacement, stackable and small cabinet or IGBT replacement, big cabinet
		<ul style="list-style-type: none"> Examine the output measure PCB Replace the output measure PCB, if necessary. See Output measure PCB (EPS442) replacement
		<ul style="list-style-type: none"> Examine the IGBT PCB If necessary, replace the IGBT power bridge that contains the IGBT PCB. See IGBT replacement, stackable and small cabinet or IGBT replacement, big cabinet

9.3 Checks and measurements

9.3.1 Measure input voltage

1. Make sure that the main switch is **OFF**.
2. Make sure that the input supply cables that come from the mains distribution panel are only connected to the equipment you want to measure.
3. Switch on the mains distribution to feed the equipment you want to measure.
4. Make sure that all connectors are securely tightened.
5. Measure the input voltage (V) to the equipment. Use a True RMS Multimeter.
6. Check the nameplate of the equipment and make sure that the input voltage is compatible with the equipment.

9.3.2 Measure output current

1. Make sure that main switch is **OFF**.
2. Install a calibrated True RMS multimeter with a current clamp in the output circuit.
3. Switch on the equipment and set the equipment to the highest brightness step. See [Select brightness step](#).
4. Read the output current from the True RMS multimeter.
5. Make sure that the measurement is accurate. Calibrate the output current again if necessary.

9.3.3 Check fuse breaker and voltage of switch board

1. Make sure that the main switch is **OFF**.
2. Check the nameplate of the equipment to make sure that the fuse breaker voltage and the current rating of the switchboard is compatible with the equipment. Allowed variance by standards:
 - IEC: +10%
 - FAA: $\pm 10\%$
3. Set the main switch to **ON**.
4. Measure the voltage (V) of the switchboard. Use a calibrated True RMS multimeter.

9.3.4 Calculate minimum insulation resistance of series circuit

1. Calculate the minimum insulation resistance of the series circuit. See [Calculate minimum insulation resistance of series circuit](#).
2. Make sure that the calculated values are higher than the values measured during commissioning.

9.3.5 Calculate resistance of series circuit

$$R_{\text{prim}} = \rho \times L/A + y \times 0.1212$$

Where:

- R_{prim} = resistance of the series circuit in Ohm
- $\rho = 18 \times 10^{-3}$ (Ohm \times mm²)/m
- L = length of the circuit in m
- A = section of the cable in mm²
- y = number of series transformers in the circuit

Example:

circuit length is 8000 m

cable section is 6 mm²

number of series transformers is 122

Then $R_{\text{prim}} = (18 \times 10^{-3}) \times 8000/6 + 122 \times 0.1212 = 36.7$ Ohm

9.3.6 Measure cable capacitance

Measure the cable capacitance towards the ground as follows:

1. Make sure that the main switch is **OFF**.
2. Connect a multimeter to the regulator output cable. Use a Multimeter that has an internal resistance of 10 MOhm.
3. Disconnect the 500 V DC power cable to the EFD module. The Multimeter now measures the discharge time of the cable capacitance from 400 V DC to 147 V DC.

If the cable capacitance is 1 pF, the measured voltage decreases from 400 V DC to 147 V DC ($=0.37 \times 400$) in approximately 10 seconds.

If the voltage you measure with the LFD module connected is already 330 V DC, the cable leakage resistance is approximately 10 MOhm. In this case, the discharge time is approximately 5 seconds for a cable capacitance of 1 pF.

10.0 Maintenance



WARNING

- Only personnel authorized to work on high-voltage equipment can do maintenance work on the equipment.
- Operate the equipment under local control when you do maintenance work on the equipment to prevent the equipment from being accidentally switched **ON**.
- Follow all local safety procedures.
- Make sure that you have obtained the necessary permissions according to the local operation procedures and procedures regarding HV equipment.

10.1 Preventive maintenance schedule

Table 15: Preventive maintenance schedule

Frequency	Check	Action
In accordance with ICAO Aerodrome Design Manual Part 9 Airport Maintenance practices or in accordance with local maintenance regulations. Adapt the maintenance frequency to the local conditions	Examine the operation of the equipment on all brightness steps on all readings	Use a PC to log the data, if required
	Input voltage	If the input voltage is not within the limits, tell the power company to adjust the voltage. Make sure that you do the necessary actions to align the input voltage with the input limitations
	Output current. Use a calibrated True RMS multimeter and/or a current clamp.	If the output current is not within tolerance, calibrate the output current again
	Visually: <ul style="list-style-type: none"> ▪ that the wiring of the equipment and the circuit is not damaged ▪ for rust spots and general damage ▪ the housing for dust accumulation ▪ all signs on the equipment for legibility and damage 	<ul style="list-style-type: none"> ▪ Repair damaged or loose wires ▪ Replace damaged components ▪ Clean and repair rust spots ▪ Clean the inside of the equipment with an dry air blower
	If the electrical connections (e.g. input connections, output connections) are tightened correctly	Make sure that all connections are tightened

10.2 Part replacement



WARNING

- Make sure you have read and understood all safety procedures and standards related to this equipment. See [Safety](#).
- Make sure you switch **OFF** the power to the equipment. See [Switch OFF the power supply](#).
- Make sure you switch **OFF** the manual switch to remove all power to the equipment.



CAUTION

While you carry out maintenance:

- Do not drop screws or nuts inside the equipment cabinet. Collect loose nuts and screws immediately.
 - To identify all cables you disconnect, label the cables.
 - Make sure that you change the correct PCB.
 - You have saved the equipment settings as a profile. To do this in the configuration software tool, see [Install and operate the configuration software tool](#).
 - Put in the new parts exactly the same way as the parts you removed.
 - After you replace a part, test the equipment to make sure it is replaced correctly.
-



Note

Refer to the electrical schemes inside the equipment cabinet for the connection schemes.

10.2.1 Required tools

Measurement tools

- True RMS Multimeter
-



CAUTION

The output voltage of the 30 kVA / 6.6 A equipment can reach approximately 4600 V at full load. An isolating measurement transformer for use on the 5000 V AC line is recommended.

- Multimeter
 - Insulation tester "Megger" 500 V or 1000 V
 - Clamp or A-meter true RMS scale 10 and 30 A
-



CAUTION

The current regulation is +/- 1%. To make an acceptable readjustment of the output current, the accuracy of the meter must be better than 0.5% for the adjusted value.

Other tools

- Standard electrical and mechanical tool kit
- Screwdrivers with protection up to 1000 V
- Spanner set (ring or socket spanners)
- Allen keys 4 and 6 mm
- Torque screwdrivers (2 - 10 Nm) and adaptors
- Short, slotted screwdriver
- Magnet rod for collecting loose items
- Angle socket wrench

10.2.2 CPU PCB (EPS479) replacement



CAUTION

If you install an OVP version of the CPU PCB, make sure that the diode bridge PCB is also an OVP version.

If you install a non-OVP version of the CPU PCB, make sure that the diode bridge PCB is also a non-OVP version.

Make sure that you update the correct firmware. The firmware code for an OVP version of the PCB ends with an 'e'.

For parts, see [Parts list](#).

- CPU PCB
- Firmware

Remove panel

- Remove the front panel. See [Remove panels](#).

Disconnect

1. Disconnect the connectors and the wires (A).
2. Remove the fasteners (B).
3. Remove the CPU PCB (C).

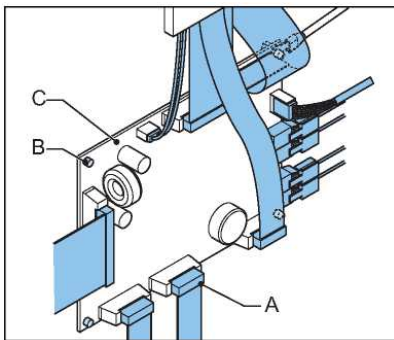

Install

1. Install the new CPU PCB.
2. Install the fasteners.
3. Connect all the wires.



CAUTION

Connect the keyboard cable with the green side down.

Update the firmware

1. Update the firmware. See [Firmware update](#).
2. Install the front panel. See [Remove panels](#).

10.2.3 CS PCB (PCB1619) replacement (option CS)

For parts, see [Parts list](#).

- CS PCB

Figure 23: CS PCB

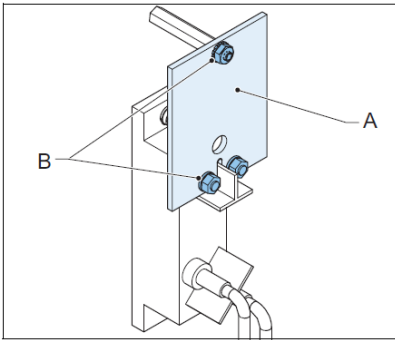

1. Switch **OFF** the power supply. See [Switch OFF the equipment](#).
2. Remove the rear panel. See [Remove panels](#).
3. Disconnect the cables from the CS PCB that you need to replace (A).
4. Remove the fasteners (B).
5. Replace the CS PCB.
6. Install the fasteners (A).
7. Connect the cables to the connectors.
8. Install the rear panel.

10.2.4 CS Relay replacement (option CS)

For parts, see [Parts list](#).

- CS relay

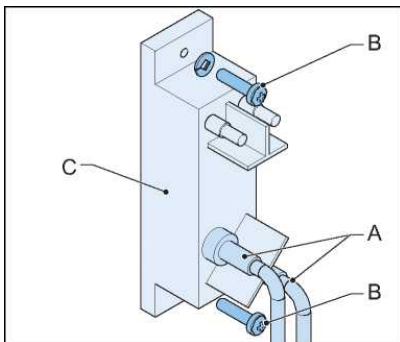

1. Switch **OFF** the power supply. See [Switch OFF the equipment](#).
2. Remove the rear panel. See [Remove panels](#).
3. Remove the CS PCB. See [CS PCB \(PCB1619\) replacement \(option CS\)](#).
4. Disconnect the cables (A) from the output terminals.
5. Remove the fasteners (B).
6. Replace the CS relay (C).
7. Install the fasteners.
8. Connect the cables to the output terminals.
9. Install the CS PCB. See [CS PCB \(PCB1619\) replacement \(option CS\)](#).

10.2.5 Diode bridge + sensing PCB (EPS476 / EPS507) replacement, small and stackable cabinet



CAUTION

If you install an OVP version of the CPU PCB, make sure that the diode bridge + sensing PCB is also an OVP version.

If you install a non-OVP version of the CPU PCB, make sure that the diode bridge + sensing PCB is also a non-OVP version.

Make sure that you update the correct firmware. The firmware code for an OVP version of the PCB ends with an 'e'.

For parts, see [Parts list](#).

- Diode bridge + sensing PCB



Note

The IGBT PCB, IGBT module, and the diode bridge and sensing PCB together are the IGBT power bridge. If one component breaks, replace the entire IGBT power bridge.

Prepare

- Remove the front panel by way of preparation. See [Remove panels](#).

Remove

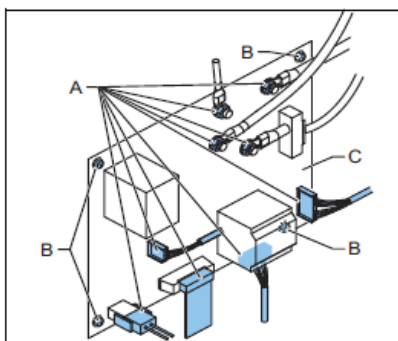

1. Disconnect the wires and connectors (A).
2. Remove the fasteners (B).
3. Remove the diode bridge + sensing PCB (C).

Install

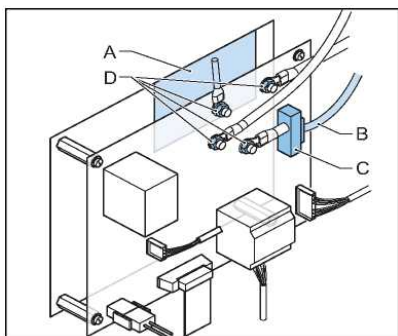

1. Wipe clean the copper plate (A).
2. Apply an even layer of conductive paste on the copper plate.
3. Install the new diode bridge on the new sensing PCB.

4. Make sure that the diode bridge makes good contact with the heatsink.



CAUTION

If there is a washer or a screw between the diode bridge and the heatsink, the heat dissipation is not sufficient.

5. Connect the wires.



CAUTION

Carefully put the wire (B) through the sensing transformer (C). The sensing transformer is easily damaged.

6. Tighten the fasteners (D). Apply a torque of 2 Nm.
7. Install the front panel. See [Remove panels](#).
8. On the HMI, check the firmware version. The firmware code for an OVP version of the PCB ends with an 'e'.
9. If the firmware version is not correct, update the firmware version. See [Firmware update](#).

10.2.6 Diode bridge and sensing PCB (EPS476) replacement, big cabinet



CAUTION

If you install a non-OVP version of the CPU PCB, make sure that the diode bridge and sensing PCB are also a non-OVP version.

Make sure that you update the correct firmware. The firmware code for an OVP version of the PCB ends with an 'e'.

If you install a non-OVP version of the CPU PCB, make sure that the diode bridge and sensing PCB is also a non-OVP version.

For parts, see [Parts list](#).

- Diode bridge and sensing PCB
-



Note

The IGBT PCB, IGBT module, and the diode bridge and sensing PCB together are the IGBT power bridge. If one component breaks, replace the entire IGBT power bridge.

Prepare

:

- Remove the lower front panel. See [Remove panels](#).

Remove sensing PCB

1. Disconnect the wires and connectors (A).
2. Remove the fasteners (B).
3. Remove the sensing PCB (C).

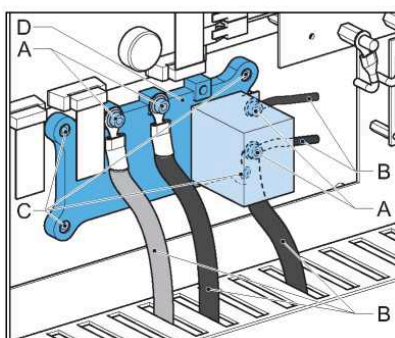
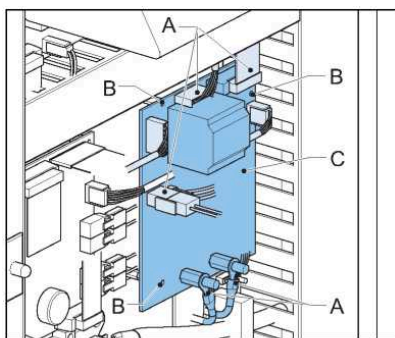

Remove diode bridge

:

1. Remove the fasteners (A).
2. Disconnect the wires (B).
3. Remove the fasteners (C).
4. Remove the diode bridge (D).

Install

1. Wipe clean the heat sink where you install the new diode bridge.
 2. Apply an even layer of conductive paste on the back side of the new diode bridge.
 3. Install the new diode bridge.
 4. Make sure that the diode bridge makes good contact with the heatsink.
-



CAUTION

If there is a washer or a screw between the diode bridge and the heatsink, the heat dissipation is not sufficient.

5. Tighten the fasteners (A). Apply a torque of 4 Nm.
6. Install the new sensing PCB.
7. Connect all the wires to the sensing PCB.
8. Tighten the fasteners (B). Apply a torque of 2 Nm.

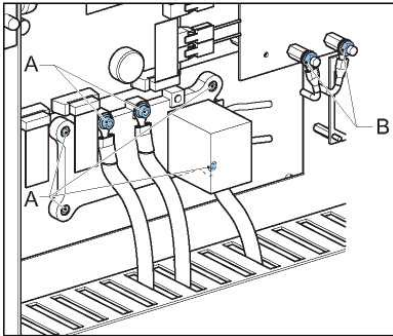

Finish

1. Install the lower front panel. See [Generic panels](#).
2. On the HMI, check the firmware version. The firmware code for an OVP version of the PCB ends with an 'e'.
3. If the firmware version is not correct, update the firmware version. See [Firmware update](#).

10.2.7 Display and keyboard replacement

For parts, see [Parts list](#).

- Display/keyboard panel
1. Remove the display/keyboard panel. See [Remove panels](#).
 2. Install the new display/keyboard panel. See [Remove panels](#).

10.2.8 Fuses on the power supply PCB (EPS480) replacement

For parts, see [Parts list](#).

- Fuses. See also [Protection devices](#).
1. Remove the lower front panel. See [Remove panels](#).
 2. To replace, push, turn counterclockwise and remove the fuse (A). If only one fuse is broken, replace only the broken fuse.

3. Install the new fuse.

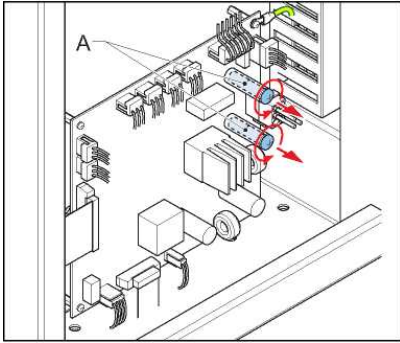

4. Install the lower front panel. See [Remove panels](#).

10.2.9 HMI SIN PCB (PCB1694) replacement (option CS)

For parts, see [Parts list](#).

- HMI SIN PCB

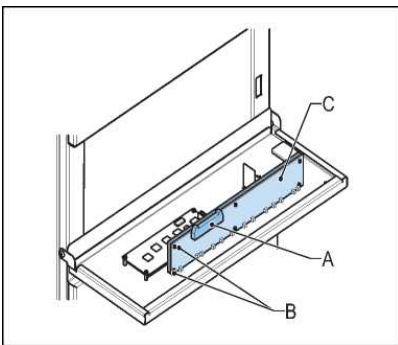

1. Remove the display/keyboard panel. See [Remove panels](#).
2. Disconnect the connectors and the wires (A).
3. Remove the fasteners (B).
4. Remove the HMI SIN PCB (C).
5. Install the new remote control PCB.
6. Connect all the wires.
7. Install the display / keyboard panel. See [Remove panels](#).

10.2.10 IGBT replacement, stackable and small cabinet

For parts, see [Parts list](#).

- IGBT



Note

The IGBT PCB, IGBT module, and the diode bridge and sensing PCB together are the IGBT power bridge. If one component breaks, replace the entire IGBT power bridge.

The illustrations for this procedure show the situation for the 2.5 kVA and 10 kVA cabinets.



CAUTION

Before switching ON the output of the CCR, the "IGBT Test" function must be activated. This reduces the risk of IGBT damage in case of incorrect installation. If the start-up is successful, the "IGBT Test" function shall be deactivated to allow normal operation of the CCR.

Remove panel

- Remove the front panel. See [Remove panels](#).

Remove 1

- Remove the fasteners (A).
- Remove the capacitor plate (B).
- Remove the IGBT PCB. See [IGBT PCB \(EPS477 / EPS 478\) replacement, small cabinet](#).

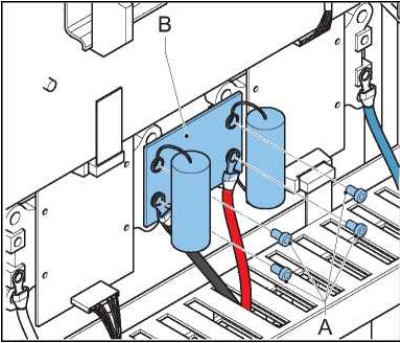

Remove 2

- Disconnect the wire (A).
- Remove the fasteners (B).
- Remove the IGBT (C).

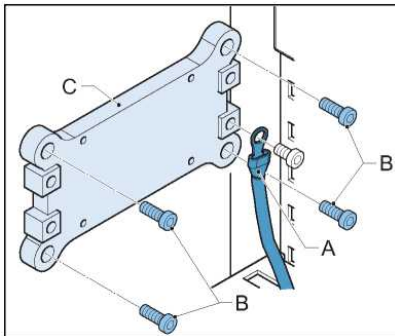

Prepare the IGBT

- Make sure that spring number 7 (A) of the IGBT is removed. Once a spring has been removed, it cannot be re-installed.

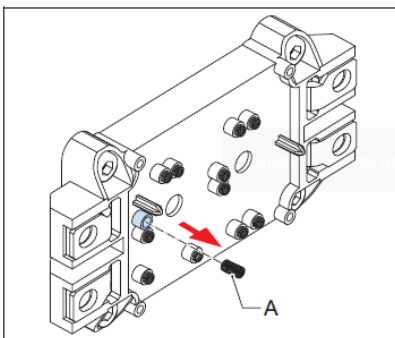

Install 1

1. Wipe clean the heat sink below the IGBT (A).
2. Apply an even layer of conductive paste on the rear of the IGBT (the side that touches the heat sink).
3. Tighten the fasteners (B) crosswise. Apply a torque of 4 Nm.

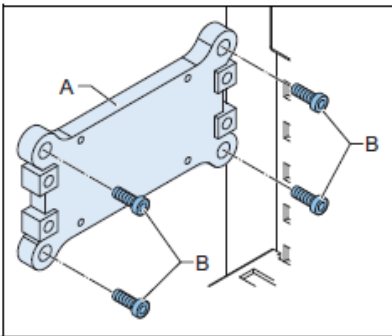

Install 2

1. Install the IGBT PCB. See [IGBT PCB \(EPS477 / EPS 478\) replacement, small cabinet](#).
2. Install the capacitor plate.
3. Connect the wires.
4. Install the fasteners (A). Apply a torque of 4 Nm.
5. Install the front panel. See [Remove panels](#).

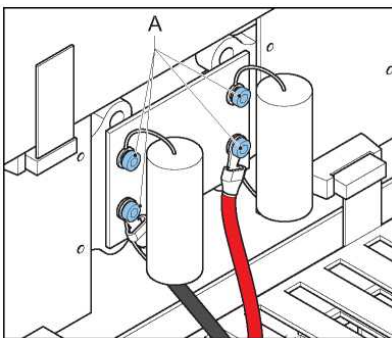

10.2.11 IGBT replacement, big cabinet

For parts, see [Parts list](#).

- IGBT



Note

- The IGBT PCB, IGBT module, and the diode bridge and sensing PCB together are the IGBT power bridge. If one component breaks, replace the entire IGBT power bridge.
- The procedure shows the IGBT at the right-hand side. The procedure for the IGBT at the left-hand side is similar.



CAUTION

Before switching ON the output of the CCR, the "IGBT Test" function must be activated. This reduces the risk of IGBT damage in case of incorrect installation. If the start-up is successful, the "IGBT Test" function shall be deactivated to allow normal operation of the CCR.

Remove

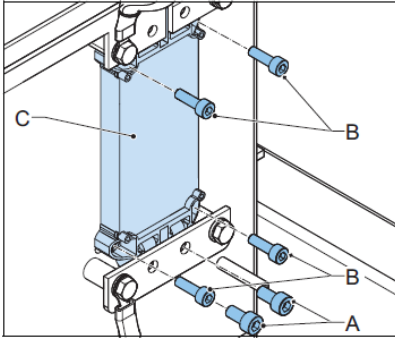

1. Remove the IGBT PCB. See [IGBT PCB \(EPS496\) replacement, big cabinet](#).
2. Remove the fasteners (A).
3. Remove the fasteners (B).
4. Remove the IGBT (C).

Install

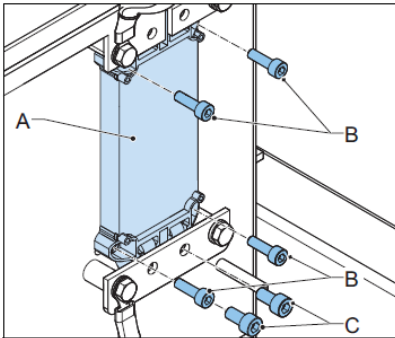

CAUTION

When you tighten the fasteners, only apply force vertically. Use an allen key screwdriver or an allen key handle instead of a socket wrench or a ratchet. Sideways force can damage components.

1. Wipe clean the heat sink below the new IGBT (A). Apply an even layer of conductive paste on the rear of the IGBT (the side that touches the heat sink).
2. Install the IGBT.
3. Install the fasteners (B). Apply a torque of 4 Nm.
4. Install the fasteners (C). Apply a torque of 4 Nm.
5. Install the IGBT PCB. See [IGBT PCB \(EPS496\) replacement, big cabinet](#).

10.2.12 IGBT PCB (EPS477 / EPS 478) replacement, small cabinet

For parts, see [Parts list](#).

- IGBT PCB



Note

The IGBT PCB, IGBT module, and the diode bridge and sensing PCB together are the IGBT power bridge. If one component breaks, replace the entire IGBT power bridge.

The illustrations for this procedure show the situation for the 2.5 kVA and 10 kVA cabinets.



CAUTION

Before switching ON the output of the CCR, the "IGBT Test" function must be activated. This reduces the risk of IGBT damage in case of incorrect installation. If the start-up is successful, the "IGBT Test" function shall be deactivated to allow normal operation of the CCR.

Remove panel

- Remove the front panel. See [Remove panels](#).

Disconnect

- Make sure that spring number 7 (A) of the IGBT is removed.
Once a spring is removed, it cannot be installed again.
- Disconnect the connectors and the wires (A).
- Remove the fasteners (B).
- Remove the IGBT PCB (C).

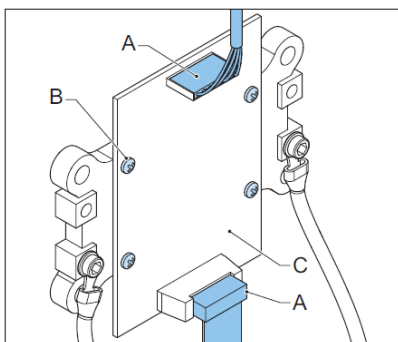

Install



CAUTION

When you tighten the fasteners, only apply force vertically. Use an allen key screwdriver or an allen key handle instead of a socket wrench or a ratchet. Sideways force can cause the components to get damaged.

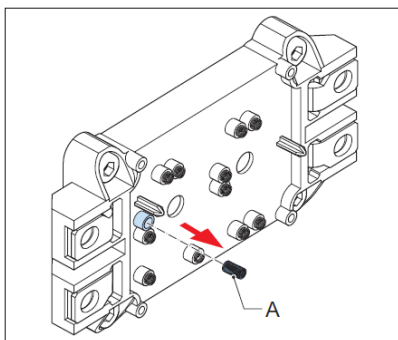

- Make sure that spring number 7 (A) of the IGBT is removed. Once a spring has been removed, it cannot be reinstalled
- Install the new IGBT PCB.
- Connect all the wires.
- Install the front panel. See [Remove panels](#).

10.2.13 IGBT PCB (EPS496) replacement, big cabinet

For parts, see [Parts list](#).

- IGBT PCB



Note

The IGBT PCB, IGBT module, and the diode bridge and sensing PCB together are the IGBT power bridge. If one component breaks, replace the entire IGBT power bridge.

The procedure shows the IGBT PCB at the right-hand side. The procedure for the IGBT PCB at the left-hand side is similar.



CAUTION

Before switching ON the output of the CCR, the "IGBT Test" function must be activated. This reduces the risk of IGBT damage in case of incorrect installation. If the start-up is successful, the "IGBT Test" function shall be deactivated to allow normal operation of the CCR.

Remove panel

- Remove the lower front panel. See [Remove panels](#).

Remove

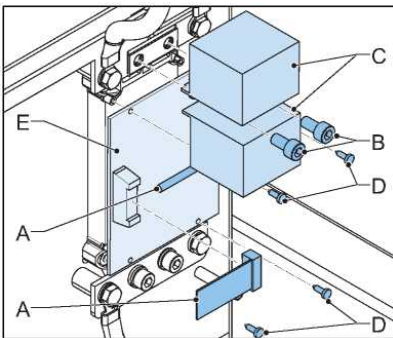

1. Disconnect the wires (A).
2. Remove the fasteners (B).
3. Remove the capacitors (C).
4. Remove the fasteners (D).
5. Remove the IGBT PCB.

Remove the spring from the IGBT

- Make sure that spring number 7 (A) of the IGBT is removed. Once a spring has been removed, it cannot be reinstalled.

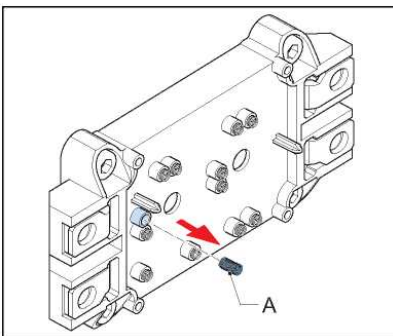

Install



CAUTION

When you tighten the fasteners, only apply force vertically. Use an alien key screwdriver or an allen key handle instead of a socket wrench or a ratchet. Sideways force can cause the components to get damaged.

1. Install the new IGBT PCB (A) on the IGBT.
2. Install the fasteners (B) crosswise. Apply a torque of 4 Nm.
3. Install the capacitors (C).
4. Install the fasteners (D). Apply a torque of 4 Nm.
5. Connect the wires (E).

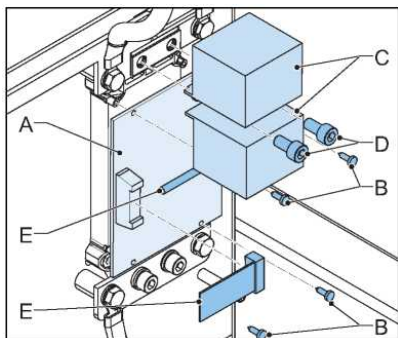

10.2.14 Input filter replacement, stackable cabinet

For parts, see [Parts list](#).

- Input filter
- Output filter



Note

Always replace the input filter and the output filter together.

The number of filters and capacities can be different from the illustrations, depending on the output power.

1. Remove the top panel. See [Remove panels](#).

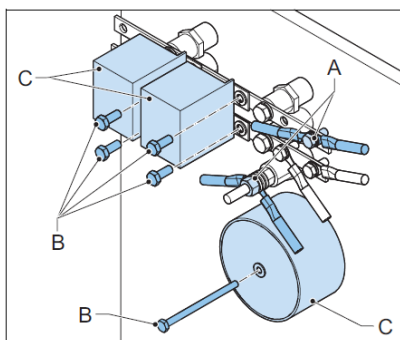

2. Disconnect the wires (A).
3. Remove the fasteners (B).
4. Remove the parts of the input filter (C).

Install:

1. Install the new parts of the input filter (A).
2. Tighten the fasteners (B). Apply a torque of 3 Nm.
3. Connect the wires.
4. Tighten the fasteners (C). Apply a torque of 6 Nm.
5. Install the top panel. See [Remove panels](#).

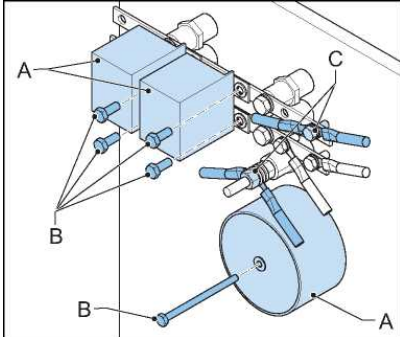

10.2.15 Input filter replacement, small (up to 10 kVA) cabinet

For parts, see [Parts list](#).

- Input filter
- Output filter



Note

Always replace the input filter and the output filter together.

The number of filters and capacities can be different from the illustrations, depending on the output power.

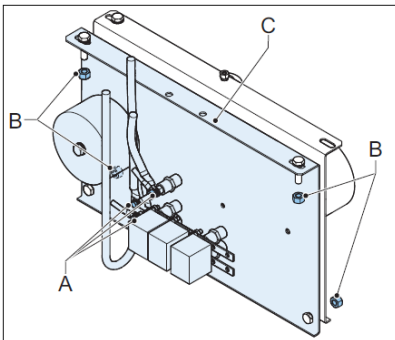

Remove:

1. Remove the side panels. See [Remove panels](#).
2. Disconnect the wires (A).
3. Remove the fasteners (B).
4. Remove the input filter plate (C).

Install:

1. Install the new input filter plate (A).
2. Tighten the fasteners (B).
3. Install the wires.
4. Tighten the fasteners (C). Apply a torque of 6 Nm.
5. Install the side panels. See [Remove panels](#).

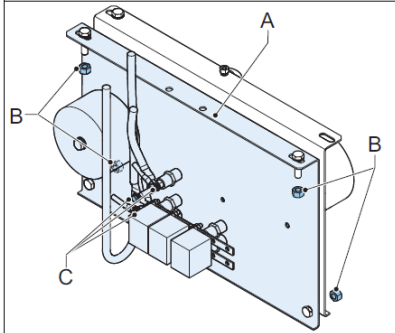

10.2.16 Input filter replacement, small cabinet (15 kVA) and big cabinet

For parts, see [Parts list](#).

- Input filter
- Output filter



Note

Always replace the input filter and the output filter together.

The number of filters and capacities can be different from the illustrations, depending on the output power.

1. Remove the side panels. See [Remove panels](#).

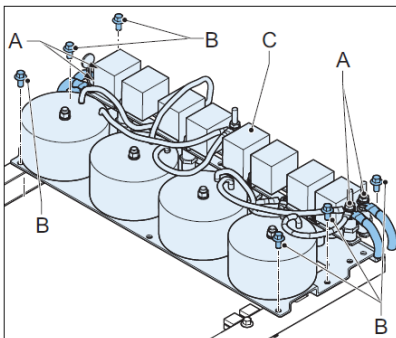

2. Disconnect the wires (A).
3. Remove the fasteners (B).
4. Remove the complete input filter (C).

Install:

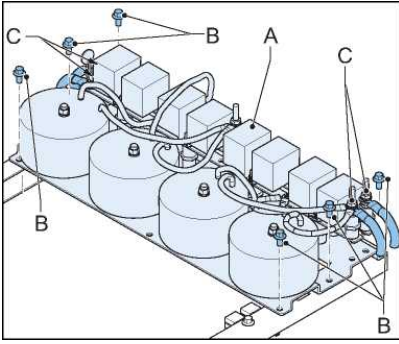

1. Install the new complete input filter (A).
2. Tighten the fasteners (B).
3. Install the wires.
4. Tighten the fasteners (C). Apply a torque of 6 Nm.
5. Install the side panels. See [Remove panels](#).

10.2.17 Interface PCB (PCB1702) replacement (option CS)

For parts, see [Parts list](#).

- Interface PCB

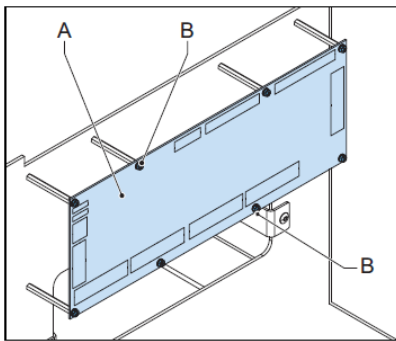

1. Switch **OFF** the power supply. See [Switch OFF the equipment](#).
2. Remove the front panel. See [Remove panels](#).
3. Disconnect the cables from the CS PCB (A).
4. Remove the fasteners (B).
5. Replace the CS PCB.
6. Install the fasteners (A).
7. Connect the cables to the connectors.
8. Install the front panel of the CS cabinet.

10.2.18 Lightning arrestors replacement, equipment with SCO or SCB

For parts, see [Parts list](#).

- Lightning arrestors



Note

The number of lightning arrestors can be different from the illustrations, depending on the output power.

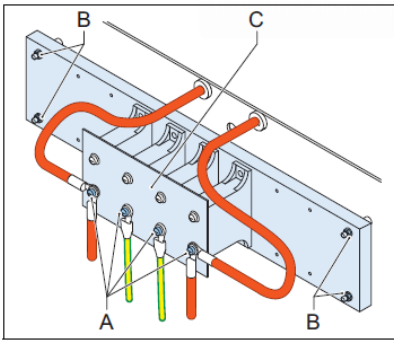

1. Remove the side panels. See [Remove panels](#).
2. Disconnect the wires (A).
3. Remove the fasteners (B).
4. Remove the lightning arrestors assembly (C).
5. Install the new lightning arrestors assembly.
6. Install the wires.
7. Install the side panels. See [Remove panels](#).

10.2.19 Line filter replacement

For parts, see [Parts list](#).

- Line filter

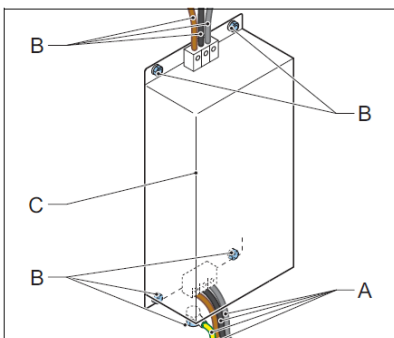

1. Remove the side panels. See [Remove panels](#).
2. Remove the lower rear panel. See [Remove panels](#).
3. Disconnect the wires (A).
4. Remove the fasteners (B).
5. Remove the line filter (C).
6. Install the new line filter.
7. Install the wires.
8. Install the lower rear panel. See [Remove panels](#).
9. Install the side panels. See [Remove panels](#).

10.2.20 Main contactor replacement, small cabinet



WARNING

Make sure that you have switched **OFF** the power to the equipment. See [Switch OFF the power supply](#).

For parts, see [Parts list](#).

- Main contactor

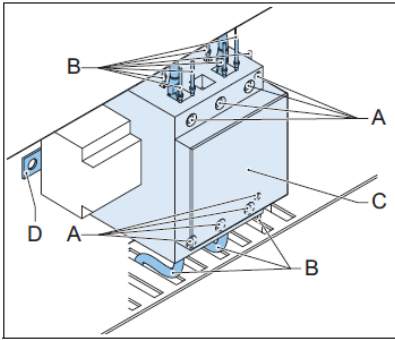

1. Remove the lower front panel. See [Remove panels](#).
2. Loosen the screws (A).
3. Disconnect the wires (B).
4. Remove the main contactor (C). Use a screwdriver as a lever to release the manual switch from the rail (D).

Install

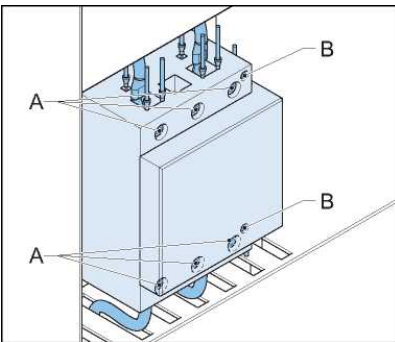

1. Install the new main contactor.
2. Connect all the wires.
3. Tighten the screws of the main power cables (A). Apply a torque of 5 Nm.
4. Tighten the screws of the auxiliary power cables (B). Apply a torque of 1.7 Nm.
5. Install the lower front panel. See [Remove panels](#).

10.2.21 Main contactor replacement, big cabinet

For parts, see [Parts list](#).

- Main contactor



WARNING

Make sure that you switched OFF the power to the equipment. See [Switch OFF the power supply](#)

1. Remove the main front panel. See [Remove panels](#).

Disconnect

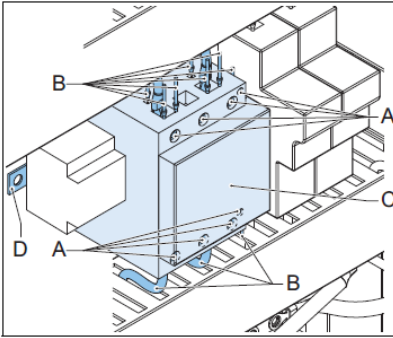

1. Loosen the screws (A).
2. Disconnect the wires (B).
3. Remove the main contactor (C). Use a screwdriver as a lever to release the manual switch from the rail (D).

Install

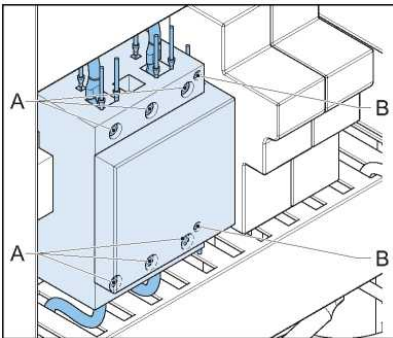

1. Install the new main contactor.
2. Connect all the wires.
3. Tighten the screws of the main power cables (A). Apply a torque of 4 Nm.
4. Tighten the screws of the auxiliary power cables (B). Apply a torque of 1.7 Nm.
5. Install the lower front panel. See [Remove panels](#).

10.2.22 Main fuses replacement

For parts, see [Parts list](#).

- Fuses. See also [Protection devices](#).

1. Remove the lower front panel. See [Remove panels](#).
2. Open the fuse holder (A).
3. Replace the fuse (B).
4. Close the fuse holder.
5. Install the lower front panel. See [Remove panels](#).

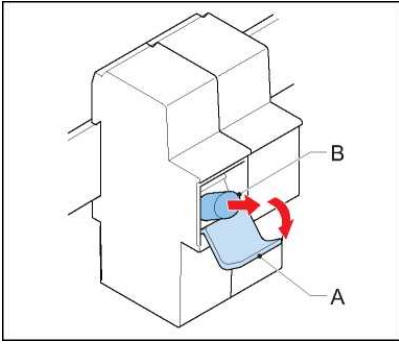

10.2.23 Manual switch replacement



WARNING

Make sure to switch **OFF** power to the equipment. See [Remove panels](#).

For parts, see [Parts list](#).

- Manual switch
1. Remove the lower front panel. See [Remove panels](#).
 2. Loosen the screws (A).

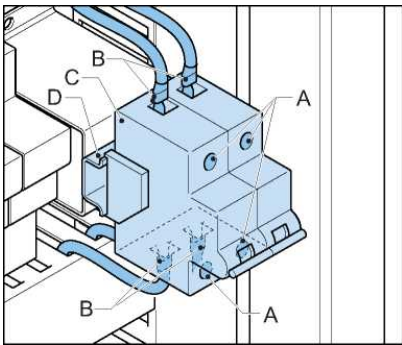

3. Disconnect the wires (B).
4. Remove the manual switch (C). Use a screwdriver as a lever to release the manual switch from the rail (D).

Install

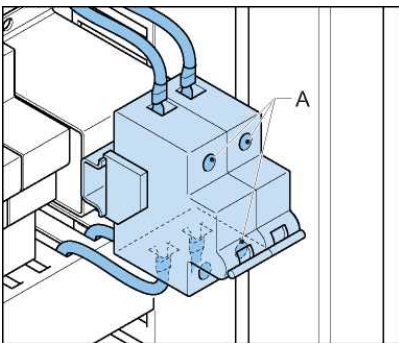

1. Install the new manual switch.
2. Connect all the wires.
3. Tighten the screws (A). Apply a torque of 4 Nm.
4. Install the lower front panel. See [Remove panels](#).

10.2.24 Output filter replacement, stackable cabinet

For parts, see [Parts list](#).

- Input filter
- Output filter



Note

Always replace the input filter and the output filter together.

The number of filters and capacities can be different from the illustrations, depending on the output power.

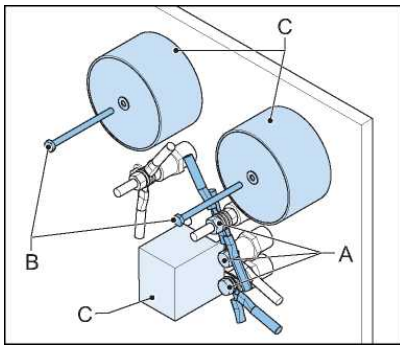

1. Remove the top panel. See [Remove panels](#).
2. Disconnect the wires (A).
3. Remove the fasteners (B).
4. Remove the parts of the output filter (C).

Install:

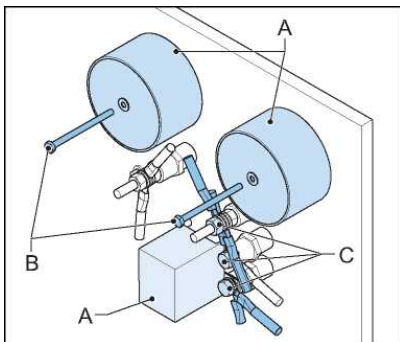

1. Install the new parts of the output filter (A).
2. Tighten the fasteners (B). Apply a torque of 3 Nm.
3. Connect the wires.
4. Tighten the fasteners (C). Apply a torque of 6 Nm.
5. Install the top panel. See [Remove panels](#).

10.2.25 Output filter replacement, small (up to 10 kVA) cabinet

For parts, see [Parts list](#).

- Input filter
- Output filter



Note

Always replace the input filter and the output filter together.

The number of filters and capacities can be different from the illustrations, depending on the output power.

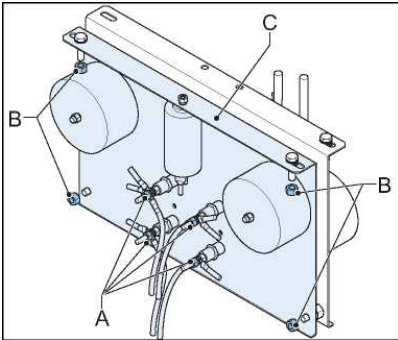

1. Remove the side panels. See [Remove panels](#).
2. Disconnect the wires (A).
3. Remove the fasteners (B).
4. Remove the output filter plate (C).

Install:

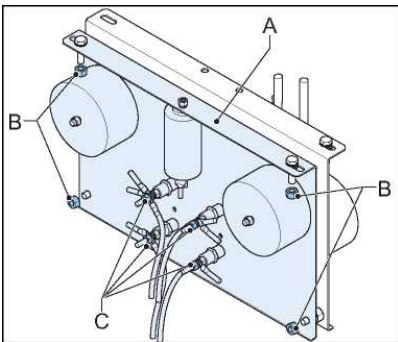

1. Install the new output filter plate (A).
2. Tighten the fasteners (B).
3. Install the wires.
4. Tighten the fasteners (C). Apply a torque of 6 Nm.
5. Install the side panels. See [Remove panels](#).

10.2.26 Output filter replacement, small cabinet 15 kVA and big cabinet

For parts, see [Parts list](#).

- Input filter
 - Output filter
-



Note

Always replace the input filter and the output filter together.

The number of filters and capacities can be different from the illustrations, depending on the output power.

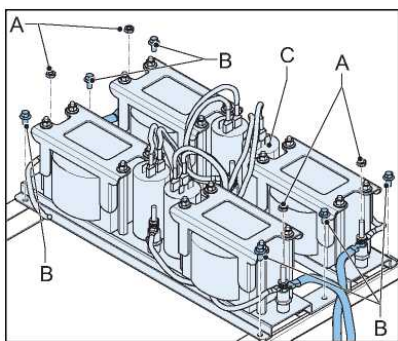

1. Remove the side panels. See [Remove panels](#).
2. Disconnect the wires (A).
3. Remove the fasteners (B).
4. Remove the complete output filter (C).

Install:

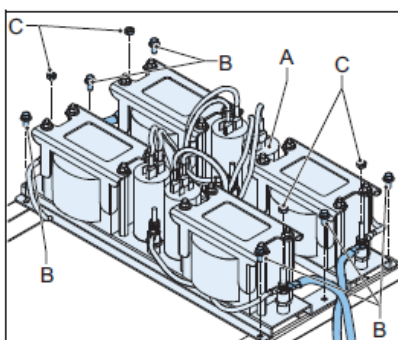

1. Install the new complete output filter (A).
2. Tighten the fasteners (B).
3. Install the wires.
4. Tighten the fasteners (C). Apply a torque of 6 Nm.
5. Install the side panels. See [Remove panels](#).

10.2.27 Output measure PCB (EPS442) replacement

Parts: see [Parts list](#).

- Output measure PCB

Remove panels

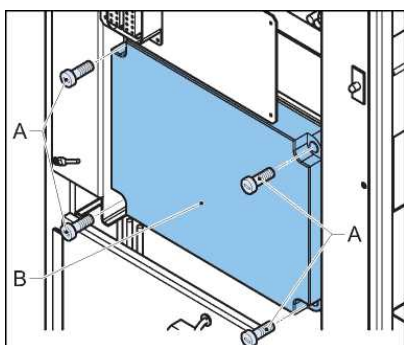

1. Remove the upper rear panel. See [Remove panels](#).
2. Remove the screws (A).
3. Remove the box panel (B).

Disconnect

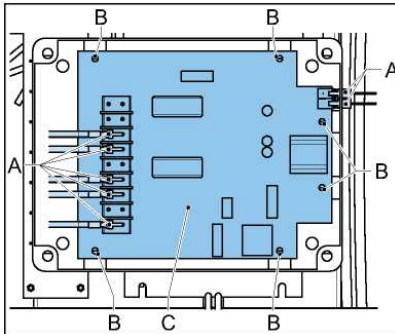

1. Disconnect the wires and connectors (A).
2. Remove the fasteners (B).
3. Remove the output measure PCB (C).

Install

1. Install the new output measure PCB.
2. Install the wires and connectors.
3. Install the box panel.
4. Install the upper rear panel. See [Remove panels](#).

10.2.28 Power supply PCB (EPS480) replacement

For parts, see [Parts list](#).

- Power supply PCB

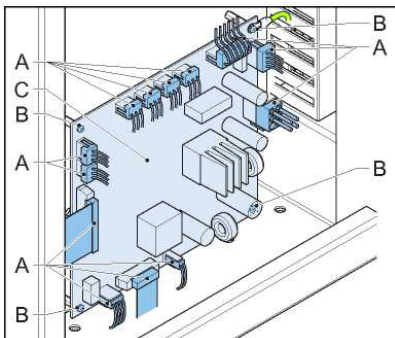

1. Remove the front panel. See [Remove panels](#).
2. Disconnect the connectors and the wires (A).
3. Remove the fasteners (B).
4. Remove the power supply PCB (C).
5. Install the new power supply PCB.
6. Connect all the wires.
7. Install the front panel. See [Remove panels](#).

10.2.29 Remote control PCB (EPS495 or EP00051) replacement

For parts, see [Parts list](#).

- Remote control PCB or remote control PCB SIN



Note

The procedure is similar for the replacement of the remote control PCB SIN.

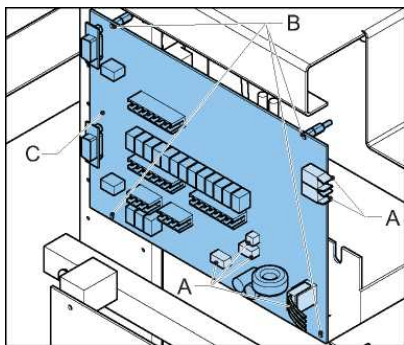

1. Remove the upper rear panel. See [Remove panels](#).
2. Disconnect the connectors and the wires (A).
3. Remove the fasteners (B).
4. Remove the remote control PCB (C).
5. [Only applicable to EPS495.] Set the dip-switches of the new remote control PCB. See [Remote Control PCB](#).
6. Install the new remote control PCB.
7. Connect all the wires.



CAUTION

Depending on the configuration of the equipment, other wires need to be connected. These can be different from the illustration above.

8. Install the upper rear panel. See [Remove panels](#).

10.2.30 Series CutOut (SCO) replacement (option)

For parts, see [Parts list](#).

- Series CutOut (SCO)

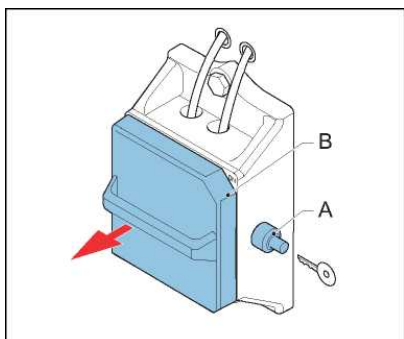

Prepare

1. Switch Off the power supply. See [Switch OFF the power supply](#).
2. Make sure that the circuit is earthed.
3. Open the lock (A).
4. Remove the cover (B). Use the handle.

Remove

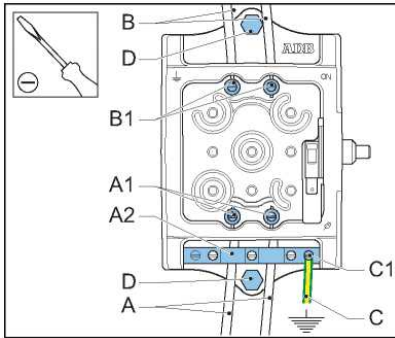

1. Loosen the screws (A1).
2. Remove the series circuit cables from the earthing bar (A2).
3. Disconnect the series circuit cables (A).
4. Loosen the screws (B1).
5. Disconnect the output cables (B).
6. Loosen the screw (C1)
7. Disconnect the earthing wire (C).
8. Remove the bolts (D).
9. Remove the SCO.

Connect the micro switch

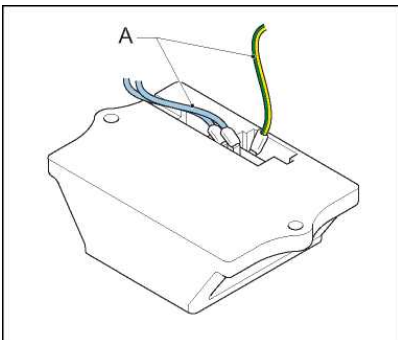

1. Disconnect the cables to the micro switch (A).
2. Connect the cables to the micro switch (A) in the new SCO.

Install

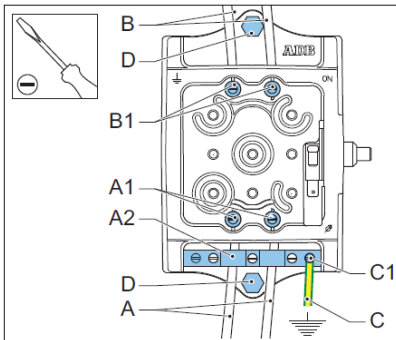

1. Install the new SCO.
2. Install the bolts (D).
3. Connect the earthing wire (C). Use the screw connection (C1).
4. Connect the output cables (B).
5. Tighten the screws B1.
6. Connect the series circuit cables (A).
7. Tighten the screws (A1).
8. Connect the wires to the earthing bar (A2).
 - Make the connection of the shield of the cable to the earthing bar.
 - If there is no shield on the cable, connect a clamp to the outside of the cable.

Finish

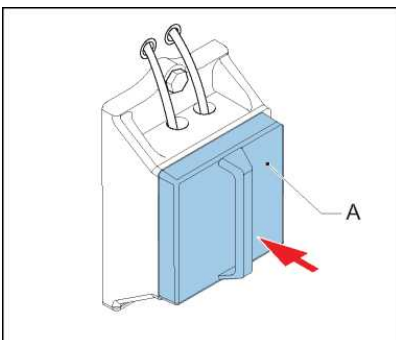

- Install the cover of the SCO (A).

10.2.31 Series Connection Box (SCB) replacement (option)

For parts, see [Parts list](#).

- Series Connection Box (SCB)

Prepare

1. Switch **OFF** the power supply. See [Switch OFF the power supply](#).
2. Make sure that the circuit is earthed.

Remove panel

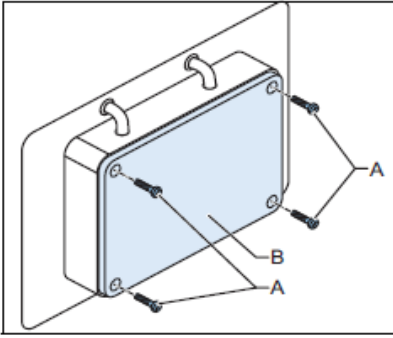

1. Loosen the fasteners (A).
2. Remove the box panel (B).

Remove

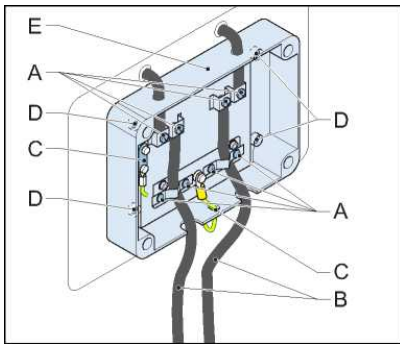

1. Loosen the screws (A).
2. Disconnect the series circuit cables (B).
3. Disconnect the wires and connectors (C).
4. Loosen the screws (D).
5. Carefully remove the SCB (E).

Install

1. Install the new SCB.
2. Put the series circuit cables through the stress-relief clamps.
3. Tighten the screws of the stress-relief clamps.
4. Install all the wires and connectors.
5. Install the box panel.

10.3 Remove panels

The panels of the equipment can be removed for installation or maintenance procedures.



WARNING

- Do not operate the equipment with any of the panels removed
- Always connect the earthing wires before you install the panels
- The panels can be heavy, especially the side panels
- Do not change or lock the panel switches. A panel switch sees if a panel is installed or not.



Note

The panels differ in size and number of screws. The illustrations below show the principle.

10.3.1 Generic panels

Remove panel

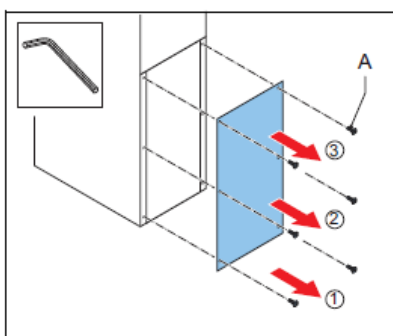

1. Set the manual switch to the **Off** position.
2. Remove the screws (A) from the bottom to the top.



WARNING

The panels are heavy. Also, the momentum of the panel can cause damage to the panel and the screws if you remove the top screws first.

3. Carefully remove the panel (B).



CAUTION

Take care to not damage cables and connectors.

Disconnect wires

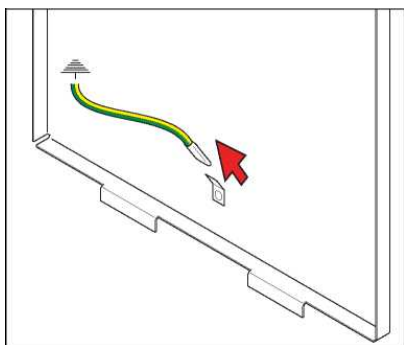

- Disconnect the green/yellow earthing wires. The wires have a fast-on connector.

10.3.2 Remove the display / keyboard panel of the small cabinet

Disconnect HMI

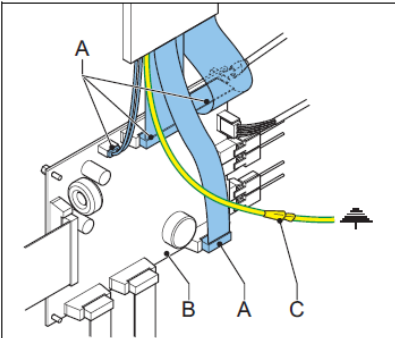

1. Remove the front panel. See [Generic panels](#).
2. Disconnect the wires (A) to the HMI from the CPU PCB (B).
3. Disconnect the earthing wire (C).

Remove panel

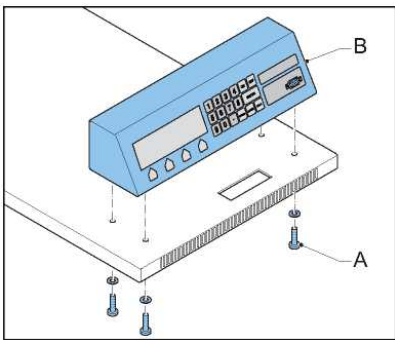

1. Remove the top panel. See [Top panel \(small cabinet\)](#).
2. Remove the screws (A).
3. Carefully remove the panel (B).



CAUTION

Take care not to damage cables and connectors.

10.3.3 Remove the display / keyboard panel of the big cabinet

Disconnect HMI

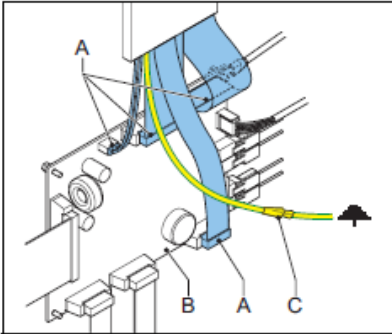

1. Remove the lower front panel. See [Top panel \(small cabinet\)](#).
2. Disconnect the wires (A) to the HMI from the CPU PCB (B).
3. Disconnect the earthing wire (C).

Remove panel

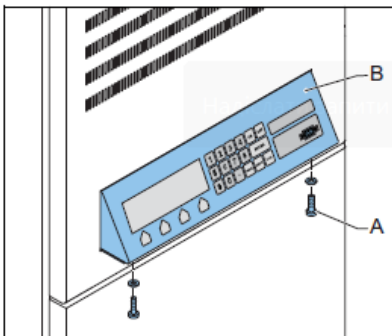

1. Remove the screws (A).
2. Carefully remove the panel (B).



CAUTION

Take care not to damage cables and connectors.

10.3.4 Remove the display / keyboard panel of a cabinet with a CS (option CS)

Open panel:

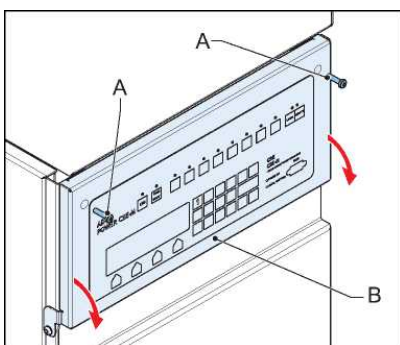

1. Remove the screws (A).

2. Open the panel (B) downwards.

Disconnect HMI:

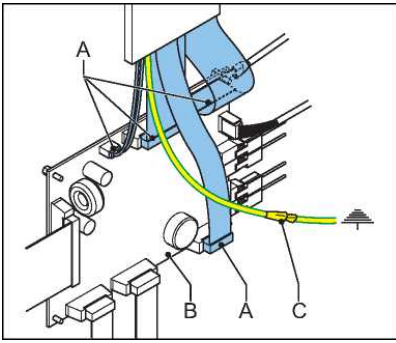

1. Disconnect the wires (A) to the HMI from the CPU PCB (B).
2. Disconnect the earthing wire (C).

Remove panel:

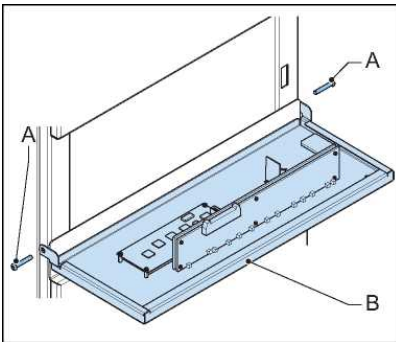

1. Remove the screws (A).
2. Remove the panel (B).

10.3.5 Top panel (small cabinet)

Disconnect HMI

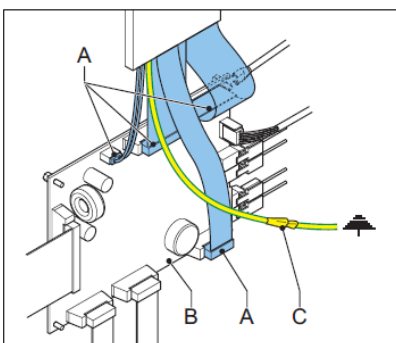

1. Remove the front panel. See [Generic panels](#) .
2. Disconnect the wires (A) to the HMI from the CPU PCB (B).
3. Disconnect the earthing wire (C).

Remove

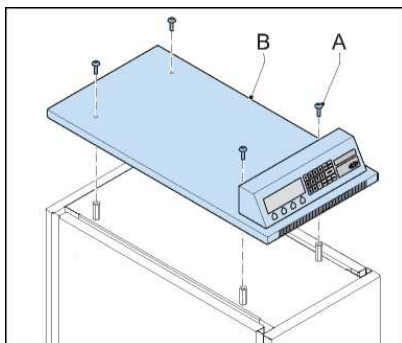

1. Remove the screws (A).
2. Remove the top panel (B).

Disconnect wires

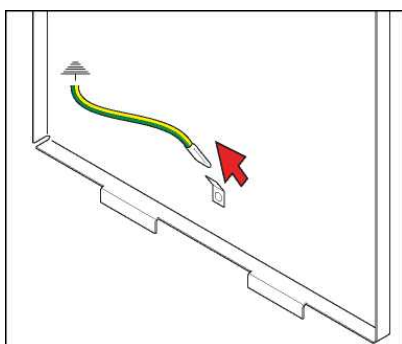

- Disconnect the green/yellow earthing wires. The wires have a fast-on connector.

10.4 Firmware update

Tools

- PC with serial port connection
- Firmware update dongle: 'Pin to Pin DB9P & DB9S cable'
- Correct firmware upload file

Firmware update procedure

1. Install the software to upload the firmware. See [Install the software to upload the firmware](#).
2. Change the SD flash file paths, if necessary. See [Change the SD Flash file paths](#).
3. Do a check on the equipment parameters. See [Check equipment parameters](#).
4. Update the firmware. See [Update the firmware](#).
5. Start the equipment after a firmware update. See [Start the equipment after a firmware update](#).

10.4.1 Install the software to upload the firmware

Install the software

1. Unzip the file 'sdflash.zip' to the default path of D:\sdflash.



Note

If you extract the zip file to a different location, see [Change the SD Flash file paths](#).

2. Run the program SDFlash.exe.
3. Select **File > Open Project**.
4. Select the 'F2812SerialFlash.sdp' project from the 'sdflash' directory.
5. If you opened the program for the first time, select the correct Emulator Address/ID.



Note

This is the same process as selecting the correct COM-port address, where C4 would equal COM 4. Refer to the device manager of the PC to find the correct address. You can change this setting later from the Project >Settings >Target tab>Emulator Address/ID drop down list.

6. Go to **File > Exit**.
7. Click **Save**.

Check the port settings

1. Go to **Start>Control Panel>System>Hardware tab>Device Manager>Ports>USB Serial Port**.
2. Right-click on **USB Serial Port**.
3. Select **Properties**.
4. Select the tab **Port Settings**.
5. In the **Advanced Settings for COM** window, do as follows:
 - Make sure that the COM Port Number is correct. Select the correct Emulator Address/ID (see earlier in this procedure)
 - Change Receive (Bytes) to 4096
 - Change Transmit (Bytes) to 4096
 - Change Latency Timer (msec) to 16

10.4.2 Change the SD Flash file paths



Note

Follow this procedure if you extracted the zip file 'sdflash.zip' to a different location than D:\sdflash.

1. Go to **Project > Settings**.
2. In the indicated tabs, change the indicated fields to the correct file path.

Tab	Field
Target	Driver
	Board File
Erase	Algorithm
Programming	Algorithm
Verify	Algorithm

3. Click **OK**.

10.4.3 Check equipment parameters

1. Start the configuration software tool. See [Start the configuration software tool](#).
2. Go to the **Configuration** screen.
3. Go to the **Identification** tab.
4. Push the **Read** button to show the firmware details.
5. Make sure that the equipment parameters below match those of the filename of the required firmware version:
 - Single Phase (CRE) or Tri-phase (VIS)
 - Input Voltage: 230V range or 400V range
 - CCR Power Rating in kVA
 - SHVS installed or SHVS not installed.
 - The type of control system. This is PPT unless specified.
6. Stop the configuration software tool. See [Stop the configuration software tool](#).
7. Switch **OFF** the equipment. See [Switch OFF the equipment](#).
8. Make sure that the manual switch is in the **OFF** position. See [Switch OFF the power supply](#).

10.4.4 Update the firmware

Prepare the equipment

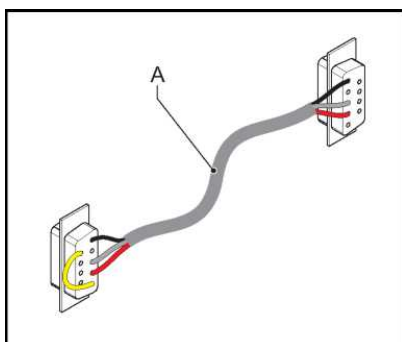

1. Remove the lower front panel. See [Generic panels](#)
2. Remove the watch-dog jumper from the CPU PCB (EPS479). See [CPU PCB \(EPS479\)](#).
3. Connect the firmware update dongle (A) between the PC and the equipment.
4. Click on SDFlash.exe.
5. Do a check if F2812SerialFlash.sdp loads.
6. If not, see [Install the software to upload the firmware](#) and load the correct project.
7. Switch ON the equipment. See [Operation](#). When the equipment is ready for the firmware upload, the HMI is blank.
8. If the HMI is not blank, see [Install the software to upload the firmware](#) and load the correct project.

Upload the firmware

1. Go to **Project>Settings>Programming tab>Flash Data File field**.
2. Select the correct firmware version file from the files with a *.out extension.
3. Go to **Device>Flash**. If asked to save changes, click **yes**.
4. Make sure that the **Erase, Program and Verify** check boxes are checked.
5. Click **Start**.
6. Wait until the upload is complete.
7. Close the SDFlash program.

10.4.5 Start the equipment after a firmware update

Start the equipment again

1. Switch **OFF** the equipment. See [Switch OFF the equipment](#).
2. Make sure that the manual switch is in the **OFF** position. See [Switch OFF the power supply](#).
3. Install the watch-dog jumper on the CPU PCB.
4. Switch **ON** the equipment. See [Operation](#).

Check if the firmware is correctly updated

1. Make sure that the firmware data on the lower line of the main menu on the HMI is correct.
2. Start the configuration software tool. See [Start the configuration software tool](#).
3. Go to the **Configuration** screen.
4. Go to the **Identification** tab.
5. Push the **Read** button to show the firmware details.

Disconnect the cable and install the front panel

1. Switch **OFF** the equipment. See [Switch OFF the equipment](#).
2. Make sure that the manual switch is in the **OFF** position. See [Switch OFF the power supply](#).
3. Disconnect the firmware update dongle.
4. Install the lower front panel. See [Generic panels](#).
5. Switch **ON** the equipment. See [Operation](#).

11.0 PCB drawings and settings

11.1 CPU PCB (EPS479)

Figure 24: Printed Circuit Board (PCB)

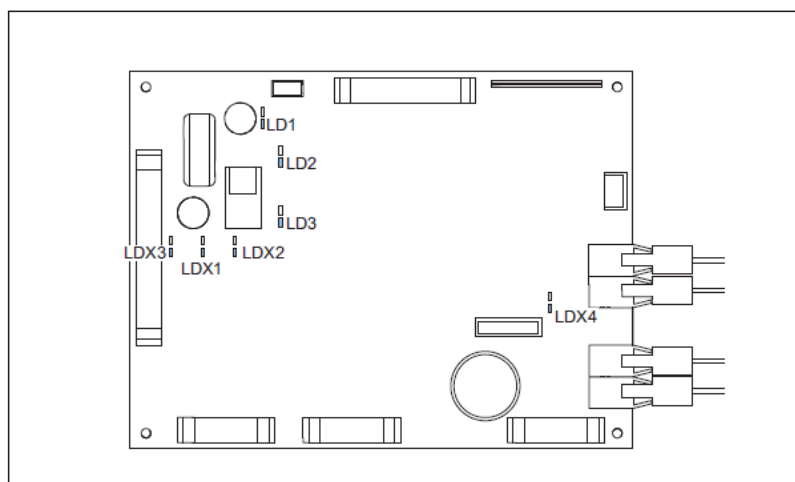

11.1.1 LEDs

Table 16: CPU PCB LED functions

LED	Color	Function
LDX1	Red	The voltage for the power supply is +5V DC (generated on the PCB)
LDX2	Red	The voltage is +5V DC
LDX3	Red	The voltage from the power supply PCB is +12 V DC
LDX4	Red	The CPU operates
LD1	Green	The voltage for the power supply on the PCB is +5 V DC (generated on the PCB)
LD2	Green	The voltage for the power supply on the PCB is +3.3 V DC (generated on the PCB)
LD3	Green	The voltage for the powers supply on the PCB is +1.8 V DC (generated on the PCB)

11.2 Power supply PCB (EPS480)

Figure 25: Printed Circuit Board (PCB)

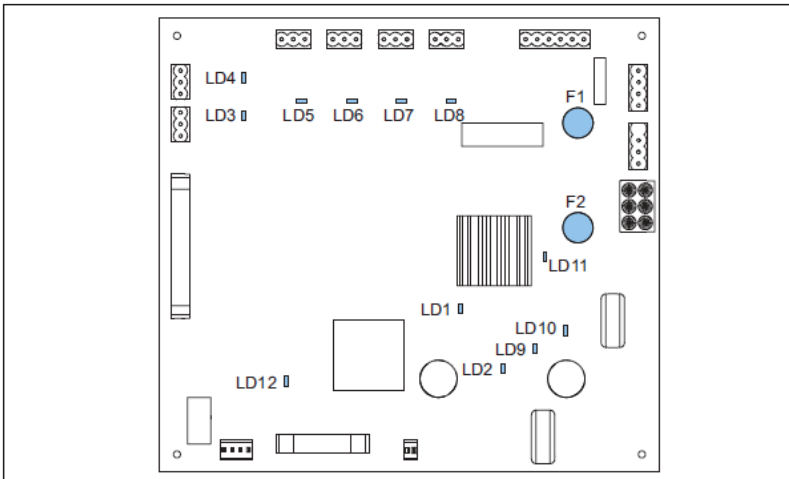

11.2.1 LEDs

Table 17: Power supply PCB LED functions

LED	Color	Function
LD1	Green	The voltage for the fans, if applicable is +24 V DC (generated on the PCB)
LD2	Red	The voltage of the power supply on the PCB is 12 V DC
LD3	Red	The fan connected to J8 is active
LD4	Red	The fan connected to J10 is active
LD5	Red	The LED is red when the fan connected to J12 is active
LD6	Red	The fan connected to J14 is active
LD7	Red	The fan connected to J16 is active
LD8	Red	The fan connected to J18 is active
LD9	Red	The the input voltage after the diode bridge PT is 24 V DC (nominal)
LD10	Red	The voltage of the power supply on the PCB is 20 V DC
LD11	Red	The sense input line voltage is 24 V AC (nominal)
LD12	Green	The voltage from the 50 kHz power supply on the PCB is 48 V DC

11.2.2 Fuses

Table 18: Power supply PCB Fuses

F1	1.6 A
F2	2.5 A

11.3 Remote Control PCB



Note

Until 2022, the CRE was delivered with the EPS495 board as the remote control PCB. Since 2022, the CRE has been delivered with the EP00047, and the EP00051 as an add-on board when Multiwire is required. The functionalities of these boards are equivalent in most cases, with the exception of the most demanding recent ALCMS systems with a redundant bus. For CRE units equipped with the EPS495, there are options to transition to the EP00047 (and the EP00051 add-on if needed) when required. Please contact your ADB SAFEGATE representative for more details if needed.

11.3.1 EPS495 (1597.00.300)

Figure 26: Printed Circuit Board (PCB)

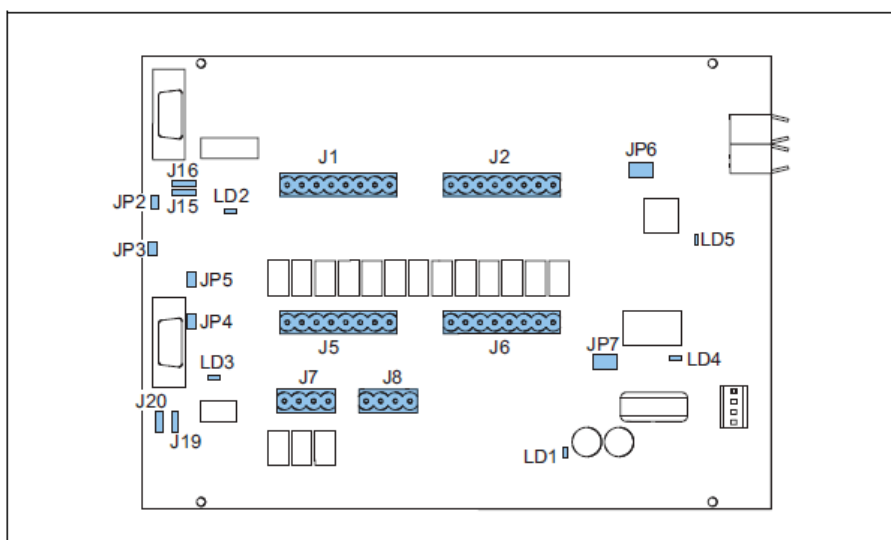

11.3.1.1 LEDs

Table 19: Remote control PCB LED functions

LED	Color	Function
LD1	Green	The LED is green when the voltage of the power supply on the PCB is 12 V DC
LD2	Green	The LED is green when the voltage from the DCDC1, generated on the PCB, is + 5 V DC insulated
LD3	Green	The LED is green when the voltage from the DCDC2, generated on the PCB, is + 5 V DC insulated
LD4	Red	The LED flashes red when the U5 CPU is active
LD5	Red	The LED flashes red when the U6 CPU is active

11.3.1.2 Jumper settings

Table 20: Remote control PCB jumper settings

Jumper	Position	Function
JP2	insert	enable TX serial channel 1 termination resistance
JP3	insert	enable RX serial channel 1 termination resistance

Table 20: Remote control PCB jumper settings

Jumper	Position	Function
JP4	insert	enable TX serial channel 2 termination resistance
JP5	insert	enable RX serial channel 2 termination resistance
JP6	position 1-3 and position 2-4 1 3 5 2 4 6	ethernet channel 1: enable
	position 3-5 and position 4-6 1 3 5 2 4 6	serial channel 1: enable
JP7	position 1-3 and position 2-4 1 3 5 2 4 6	ethernet channel 2: enable
	position 3-5 and position 4-6 1 3 5 2 4 6	serial channel 2: enable
J15	position 2-3 3 2 1	serial channel 1: RS485 configuration
	position 1-2 3 2 1	serial channel 1: RS422 configuration (not used)
Jumper	Position	Function
J16	position 2-3 1 2 3	serial channel 1: RS485 configuration
	position 1-2 1 2 3	serial channel 1: RS422 configuration (not used)
J19	position 2-3 1 2 3	serial channel 2: RS485 configuration
	position 1-2 1 2 3	serial channel 2: RS422 configuration (not used)
J20	position 2-3 1 2 3	serial channel 2: RS485 configuration
	position 1-2 1 2 3	serial channel 2: RS422 configuration (not used)

11.3.2 EP00047 and EP00051

Figure 27: Printed Circuit Board (PCB)

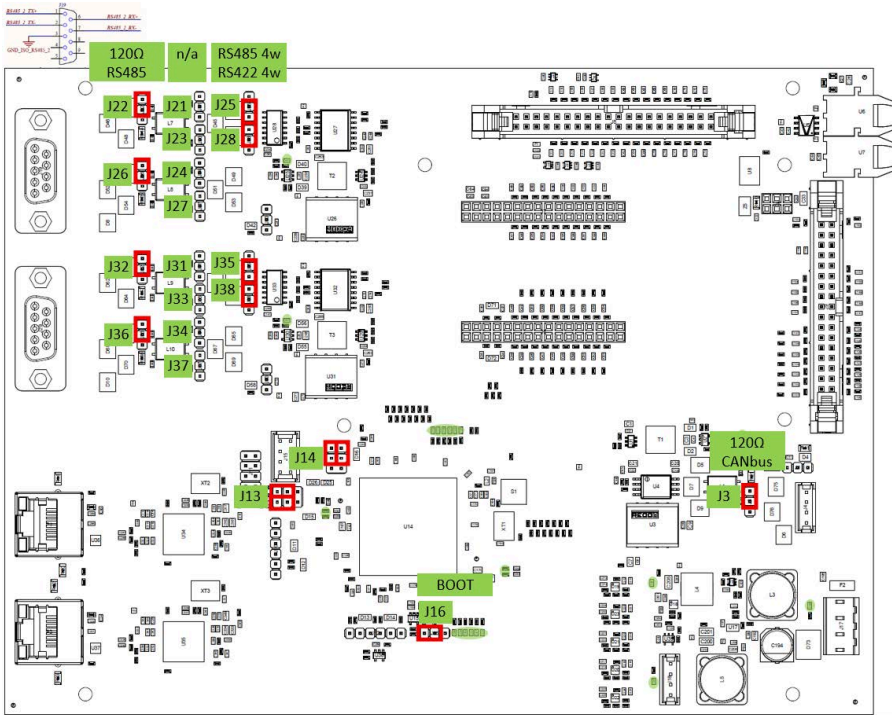

Bus A		Bus B		CAN		µProc	
J22	120 Ohm RS485_2_TX+ (1-2)	J32	120 Ohm RS485_1_TX+	J3	120 Ohm CAN (1-2)	J16	Boot-GND (2-3)
J26	120 Ohm RS485_2_RX+	J36	120 Ohm RS485_1_RX+				
J25	RS485_2_RX+ (4w:2-3, 2w:1-2)	J35	RS485_1_RX+ (4w:2-3)				
J28	RS485_2_RX- (4w:2-3)	J38	RS485_1_RX- (4w:2-3)				
J14	RS485_2 (3-5, 4-6)	J13	RS485_1 (3-5, 4-6)				

11.3.3 Multiwire/J-Bus Connection Scheme

Figure 28: Multiwire/J-Bus Pin Numbering

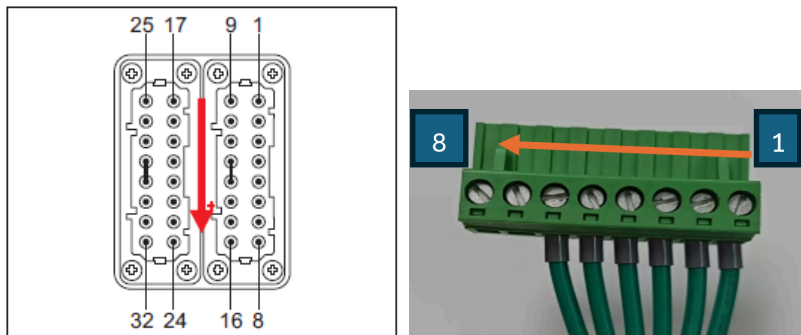

Note

The table shows the standard remote control configuration for the signals. If you want another configuration, contact ADB SAFEGATE.

Table 21:

Factory set terminal assignments for remote control connections with multiwire and single J-Bus (Cable Set 4072.30.XXX)

Function	Terminal number on 32-pole connector	Relay number on Remote Control PCB (unless indicated otherwise)
Control signals (fixed)		
Step 1 - CMD	1	J1.1
Step 2 - CMD	2	J1.2
Step 3 - CMD	3	J1.3
Step 4 - CMD	4	J1.4
Step 5 - CMD	5	J1.5
ON - CMD	6	J1.6
CCR OFF from HVCS - CMD	26	J1.7
NC	NC	J1.8
V-OUT 48V	15	J8.1
GND 48V	17	J8.2
CM – FB (general common relay return)	8	J8.3
CM – FB (general common relay return)	7, 18, J6.4	J8.4
Feedback signals (fixed)		
Step 1	9	J5.1
Step 2	10	J5.2
Step 3	11	J5.3
Step 4	12	J5.4
Step 5	13	J5.5
ON (step1,2...5) / OFF (OFF or Standby Step0)	19	J5.6
Feedback signals (configurable via HMI): the values below are default values, for configuration options (for the options, see the table that follows)		
Disable local/remote (relay 7 for both connections)	14	J5.7 (NC relay)
	28	J5.8 (NO relay)
Open circuit - FB	16	J6.1
Overcurrent - FB	20	J6.2
Bad regulation	22	J6.3
	7, 18, J8.4	J6.4 (CM)
LFD alarm (Relay 11)	23	J6.5 (NO relay)
NC	NC	J6.6
EFD warning - FB	24	J6.7
EFD error - FB	25	J6.8
High temperature alarm - FB	27	J7.1
Short circuit - FB	29	J7.2

Table 21:
Factory set terminal assignments for remote control connections with multiwire and single J-Bus (Cable Set 4072.30.XXX)

Function	Terminal number on 32-pole connector	Relay number on Remote Control PCB (unless indicated otherwise)
Lamp fault warning - FB	21	J7.3
(not used)	NC	J7.4
J-Bus interface (fixed)		
RS485 Bus A GND	30	DB9.3
RS485 Bus A +	31	DB9.1
RS485 Bus A -	32	DB9.2

Table 22: Factory set terminal assignments for remote control connections with multiwire dual J-Bus (Cable Set 4072.30.182)

Function	Terminal number on 32-pole connector	Relay number on Remote Control PCB (unless indicated otherwise)
Control signals (fixed)		
Step 1 - CMD	1	J1.1
Step 2 - CMD	2	J1.2
Step 3 - CMD	3	J1.3
Step 4 - CMD	4	J1.4
Step 5 - CMD	5	J1.5
ON - CMD	6	J1.6
CCR OFF from HVCS - CMD	7	J1.7
NC	8	J1.8
V-OUT 48V	25	J8.1
GND 48V	9	J8.2
Feedback signals (fixed)		
GND - FB	10	J8.3
GND - FB	NC	J8.4
Step 1 - FB	11	J5.1
Step 2 - FB	12	J5.2
Step 3 - FB	13	J5.3
Step 4 - FB	14	J5.4
Step 5 - FB	15	J5.5
ON (step1,2...5) / OFF (OFF or Standby Step 0 - FB)	16	J5.6
Feedback signals (configurable via HMI):		
Disable local/remote NC	NC	J5.7 (NC relay)
	NC	J5.8 (NO relay)
Open circuit - FB	17	J6.1
Overcurrent - FB	18	J6.2

Table 22: Factory set terminal assignments for remote control connections with multiwire dual J-Bus (Cable Set 4072.30.182)

Function	Terminal number on 32-pole connector	Relay number on Remote Control PCB (unless indicated otherwise)
Bad regulation	19	J6.3 (CM)
CM specific return for Relay 11	NC	J6.4
LFD alarm (Relay 11)	NC	J6.5 (NO relay)
NC	NC	J6.6
EFD warning - FB	20	J6.7
EFD error - FB	NC	J6.8
High temperature alarm - FB	NC	J7.1
Short circuit - FB	NC	J7.2
Lamp fault warning - FB	NC	J7.3
(not used)	NC	J7.4
J-Bus interface (fixed)		
RS485 Bus B GND	27	DB92.3
RS485 Bus B-	28	DB92.1
RS485 Data B+	29	DB92.2
RS485 Bus A GND	30	DB9.3
RS485 Data A -	32	DB9.2
RS485 Data A +	31	DB9.1

Figure 29: Multiwire and J-Bus Connection

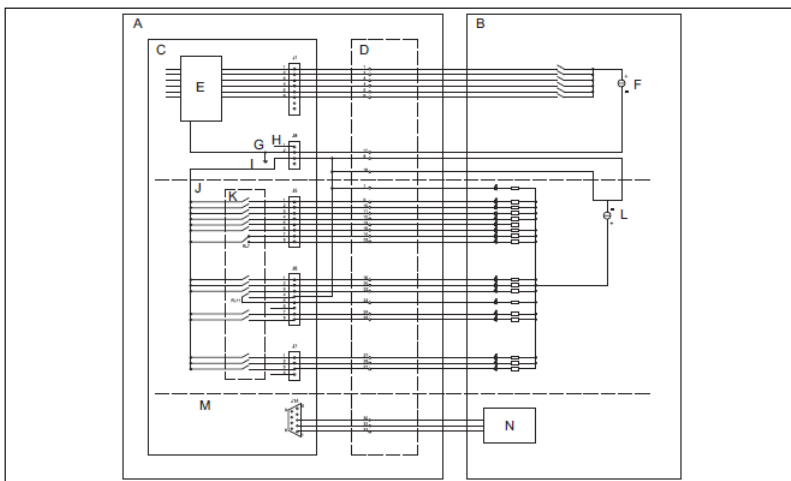

A	Equipment
B	Remote control equipment
C	Remote control PCB - input signals
D	Remote control connector on the equipment
E	Opto coupler
F	48 V DC power supply
G	Isoground
H	+48 V DC I Rel com

J	Remote control PCB - feedback signals
K	Relays
L	24 V DC power supply
M	J-Bus RS485 connection
N	J-Bus RS485 interface

11.4 IGBT PCB (EPS477 / EPS 496)

Figure 30: Printed Circuit Board (PCB) EPS477 for 2s Semix

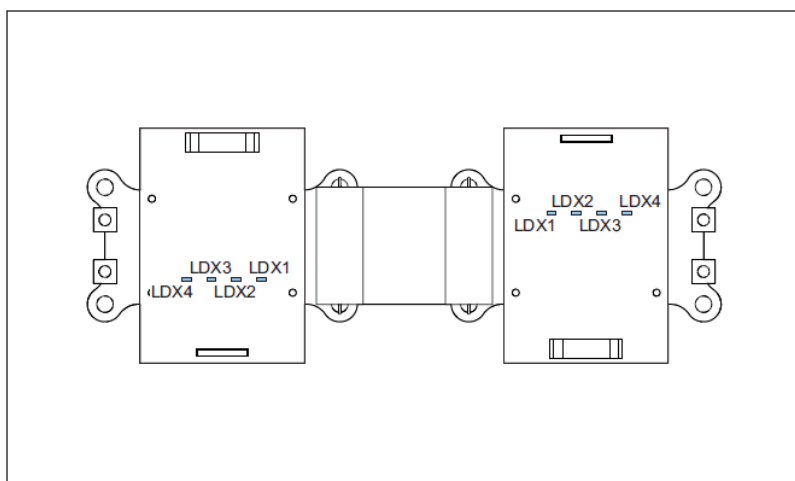

11.4.1 LEDs EPS477 for 2s Semix

Table 23: IGBT PCB LED functions

LED	Color	Function
LDX1	Red	The voltage for the high side IGBT, generated on the PCB, is +18 V DC.
LDX2	Red	The voltage for the high side IGBT, generated on the PCB, is -5 V DC.
LDX3	Red	The voltage for the low side IGBT, generated on the PCB, is +18 V DC.
LDX4	Red	The voltage for the low side IGBT, generated on the PCB, is -5 V DC.

11.4.2 Printed Circuit Board (PCB) EPS496 for 3s Semix

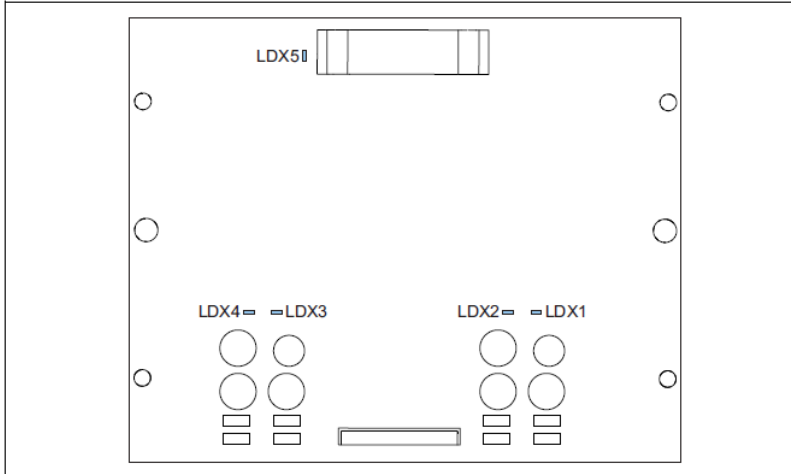

A	LDX1 - red
B	LDX2 - red
C	LDX3 - red
D	LDX4 - red
E	LDX4 - red

11.4.3 LEDs EPS477 for 1s and 2s Semix

Table 24: IGBT PCB LED functions

LED	Color	Function
LDX1	Red	The voltage for the high side IGBT, generated on the PCB, is +18 V DC.
LDX2	Red	The voltage for the high side IGBT, generated on the PCB, is -5 V DC.
LDX3	Red	The voltage for the low side IGBT, generated on the PCB, is +18 V DC.
LDX4	Red	The voltage for the low side IGBT, generated on the PCB, is -5 V DC.
LDX5	Red	The voltage for logic IC power supply is + 5 V DC.

11.5 Output measure PCB (EPS442)

Figure 31: Printed Circuit Board (PCB)

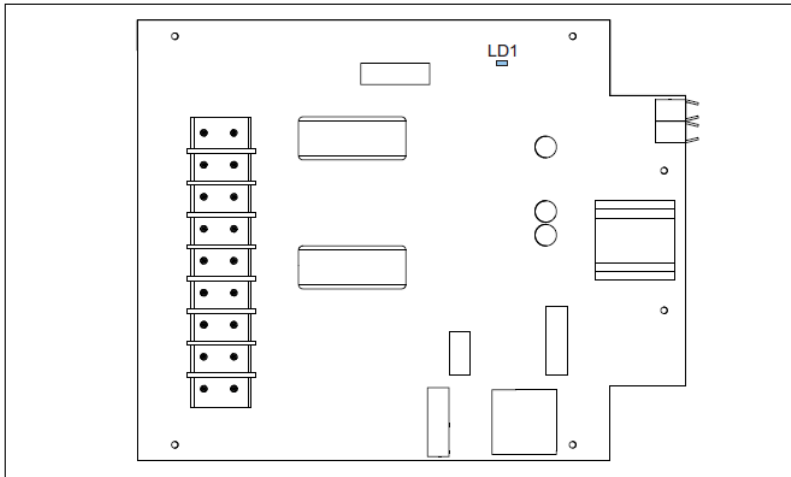

11.5.1 LEDs

Table 25: Phase bridge PCB LED RUN light functions

LED	Color	Function
LD1	Red	Flashes red when the CPU on the PCB is active.

11.6 Diode bridge and sensing PCB (EPS476 / EPS 507)

Figure 32: Printed Circuit Board (PCB)

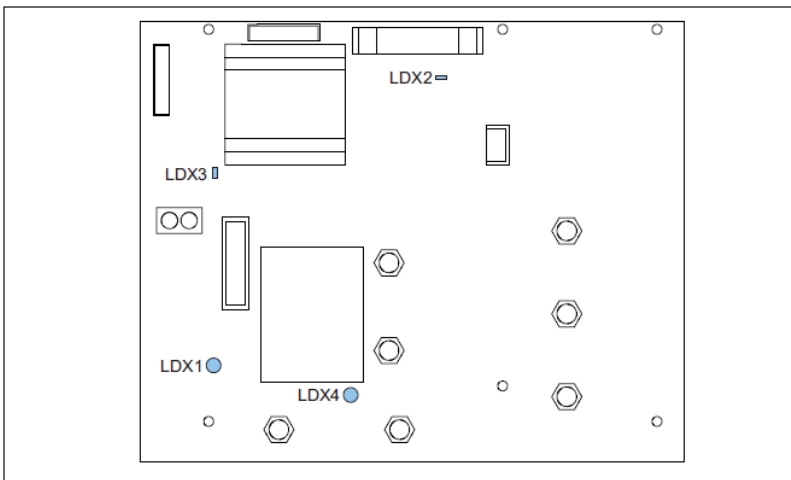

11.6.1 LEDs

Table 26: LEDs - Diode bridge and sensing PCB LED functions

LED	Color	Function
LDX1	Red	The nominal voltage for the IGBT test is 24 V DC
LDX2	Red	The voltage from the power supply PCB is +5 V DC
LDX3	Red	The voltage from the 50 kHz power supply on the PCB is +18 V DC
LDX4	Red	The nominal voltage for the IGBT bridge bus is 560 V DC

11.7 Interface PCB (PCB1702) (option CS)

Figure 33: Printed Circuit Board (PCB)

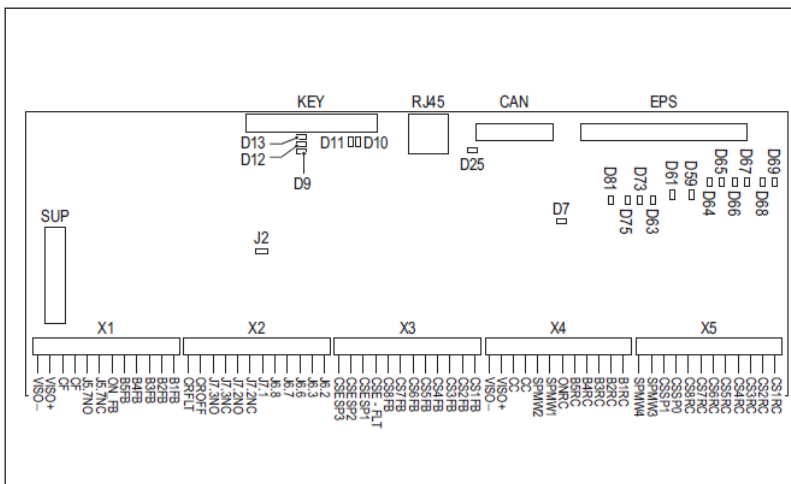

11.7.1 Jumper J2

- Installed: more than one series circuit
- Not installed: only one series circuit

11.7.2 Connectors

Table 27: 12CS connectors

Connector	Connection to	Connection point	Description
EPS	Flat cable connection to EPS495 or EP00047 (remote control PCB)		
CAN	Connection to CS PCB		
RJ45	Webpage configuration tool connection		
KEY	Flat cable connection to HMI button		
SUP	External and internal 24VDC power supply		
Connector	Connection to	Connection point	Description
X5	Remote control multiwire connection	CS1RC	Remote control input circuit 1
		CS2RC	Remote control input circuit 2
		CS3RC	Remote control input circuit 3
		CS5RC	Remote control input circuit 4

Connector	Connection to	Connection point	Description
		CS5RC	Remote control input circuit 5
		CS6RC	Remote control input circuit 6
		CS7RC	Remote control input circuit 7
		CS8RC	Remote control input circuit 8
		CSSP0	Remote control input CS spare 0
		CSSP1	Remote control input CS spare 1
		SPMW3	Remote control input equipment spare 3
		SPMW4	Remote control input equipment spare 4
X4	Remote control multiwire connection	B1RC	Remote control input brightness step 1
		B2RC	Remote control input brightness step 2
		B3RC	Remote control input brightness step 3
		B4RC	Remote control input brightness step 4
		B5RC	Remote control input brightness step 5
		ONRC	Remote control equipment ON ¹
		SPMW1	Remote control input equipment spare 2
		SPMW2	Remote control input equipment spare 1
		CC	Common for remote control signals
		CC	Common for remote control signals
		VISO+	Voltage source 24 VDC, positive pole ²
		VISO-	Voltage source 24 VDC, negative pole ²

Connector	Connection to	Connection point	Description
X3	Remote control multiwire connection	CS1FB	Feedback circuit 1
		CS2FB	Feedback circuit 2
		CS3FB	Feedback circuit 3
		CS4FB	Feedback circuit 4
		CS5FB	Feedback circuit 5
		CS6FB	Feedback circuit 6
		CS7FB	Feedback circuit 7
		CS8FB	Feedback circuit 8
		CSE-FLT	Feedback CS fault
		CSESP1CS6FB	Feedback CS, spare 1
		CSESP2CS5FB	Feedback CS, spare 2

¹ Equipment ON control can only occur through an external signal in the standard configuration. In specific configurations, and with appropriate setup, the ON control can also be managed by a brightness command. For further details, please contact your ADB SAFEGATE service representative.

² The voltage source (floating in regard to earth in this equipment) can be used as a source for the remote control signals if the positive or negative pole is connected to CC.

Connector	Connection to	Connection point	Description
		CSESP3CS4FB	Feedback CS, spare 3
X2	Remote control multiwire connection	J6.2	Feedback equipment, configured for 'Over current'
		J6.3	Feedback equipment, configured for 'Open circuit'
		J6.6	Feedback equipment, configured for 'EFD ERROR L1'
		J6.7	Feedback equipment, configured for 'EFD ERROR L2'
		J6.8	Feedback equipment, configurable spare J6.8
		J7.1	Feedback equipment, configured for 'HI TEMP'
		J7.2NC	Feedback equipment, configurable spare J7.2 NC
		J7.2NO	Feedback equipment, configurable spare J7.2 NO
		J7.3NC	Feedback equipment, configurable spare J7.3 NC
		J7.3NO	Feedback equipment, configurable spare J7.3 NO
		CROFF	Feedback equipment OFF
		CRFLT	Feedback equipment fault

Connector	Connection to	Connection point	Description
X1	Remote control multiwire connection	B1FB	Feedback equipment, configurable spare J5.1
		B2FB	Feedback equipment, configurable spare J5.2
		B3FB	Feedback equipment, configurable spare J5.3
		B4FB	Feedback equipment, configurable spare J5.4
		B5FB	Feedback equipment, configurable spare J5.5
		ON_FB	Feedback equipment ON
		J5.7NC	Feedback equipment in local mode
		J5.7NO	Feedback equipment in remote mode
		CF	Common for feedback signals
		CF	Common for feedback signals
		VISO+	Voltage source 24 VDC, positive pole ¹
		VISO-	Voltage source 24 VDC, negative pole ¹

11.7.3 LEDs

Table 28: LEDs that indicate the logic functionality

LED	Function
D7	RV3. The LED is ON if the CPU power supply is OK
D9	The LED is ON during normal operation
D10	The LED is ON if the equipment is in configuration mode The LED flashes during normal operation

¹The voltage source (floating in regard to earth in this equipment) can be used to give a voltage feedback signal if the positive or negative pole is connected to CF.

Table 28: LEDs that indicate the logic functionality

LED	Function
D11	The LED is ON if there is no CAN-bus activity The LED flashes if the CAN-bus is operational
D12	The LED is ON during normal operation
D13	The LED is ON during normal operation
D25	The LED is ON if the CAN-bus voltage (isolated 5V) is OK

Table 29: LEDs that indicate the interface functionality

LED	Function
D59	LED 'CRE_ON_IN'. The LED is ON if the equipment is operational and supplies power to the output circuit
D61	LED J5.7 IN. The LED is ON if the equipment is in remote mode
D63	LED J7.1 IN. Spare LED
D64	LED to CRE LOCREM. The LED is ON if the equipment is in local mode
D65	LED to CRE REQCON. The LED is ON if the CS requests to switch on the equipment
D66	LED CSEFLT. The LED is ON if the circuit selector is faulty (CSE-FAULT)
D67	LED SP_UC1. Spare LED
D68	LED SP_UC2. Spare LED
D69	LED SP_UC3. Spare LED
D73	LED J7.2_IN, SP IN1. Spare LED
D75	LED J7.2_IN, SP IN2. Spare LED
D81	LED 5VEPS

11.8 CS PCB (PCB1619) (option CS)

Figure 34: Printed Circuit Board (PCB)

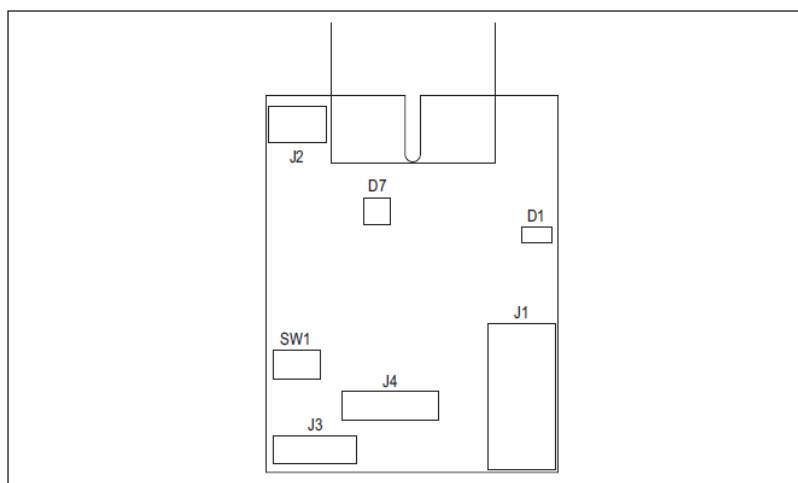

11.8.1 Connectors

Table 30: CS connectors

Connector	Connection to
J1	Flat cable to piggy with 24VDC power supply, earthing and CAN-bus
J2	Connection for the current sensor
J3	Not used
J4	Not used

11.8.2 LEDs

LED	Function
D7	<p>The LED flashes BLUE if the relay coil is not energized</p> <p>The LED flashes GREEN if the relay coil is energized</p> <p>The LED flashes RED or alternating BLUE/GREEN if there is a failure</p> <p>The LED is OFF if the PCB is not operational</p>
D1	<p>The LED is ON if the PCB is operational</p> <p>The LED is OFF if the PCB is not operational</p>

11.8.3 Dip switch

Table 31: Dip switch SW1





Dip switch setting	Function
<p>ON</p> 	Circuit 1 (Address 0)
<p>ON</p> 	Circuit 2 (Address 1)
<p>ON</p> 	Circuit 3 (Address 2)
<p>ON</p> 	Circuit 4 (Address 3)
<p>ON</p> 	Circuit 5 (Address 4)

Table 31: Dip switch SW1

Dip switch setting	Function
<p>ON</p> 	Circuit 6 (Address 5)
<p>ON</p> 	Circuit 7 (Address 6)
<p>ON</p> 	Circuit 8 (Address 7)

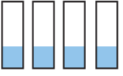
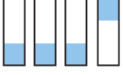
11.9 HMI SIN PCB (PCB1703) (option CS)

Figure 35: Printed Circuit Board (PCB)

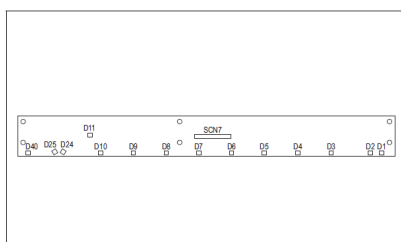

11.9.1 Connectors

Connector	Connection to
CSN 7	KEY_LED1 flat cable connection to the interface PCB (1702).

11.9.2 LEDs

LED	Colour	LED status	Description
D1	Green	ON	The CS is in remote mode
D2	Red	ON	The CS is in local mode
D3	Green	ON	Circuit 1 is selected and the equipment supplies output current
		Flashing: 0.5 s ON, 2.5 s OFF	The equipment is OFF or in stand-by
		Flashing (interval 1 s)	The CS PCB is faulty
D4	Green	ON	Circuit 1 is selected and the equipment supplies output current
		Flashing: 0.5 s ON, 2.5 s OFF	The equipment is OFF or in stand-by
		Flashing (interval 1 s)	The CS PCB is faulty
D5	Green	ON	Circuit 1 is selected and the equipment supplies output current

LED	Colour	LED status	Description
		Flashing: 0.5 s ON, 2.5 s OFF	The equipment is OFF or in stand-by
		Flashing (interval 1 s)	The CS PCB is faulty
D6	Green	ON	Circuit 1 is selected and the equipment supplies output current
		Flashing: 0.5 s ON, 2.5 s OFF	The equipment is OFF or in stand-by
		Flashing (interval 1 s)	The CS PCB is faulty
D7	Green	ON	Circuit 1 is selected and the equipment supplies output current
		Flashing: 0.5 s ON, 2.5 s OFF	The equipment is OFF or in stand-by
		Flashing (interval 1 s)	The CS PCB is faulty.
D8	Green	ON	Circuit 1 is selected and the equipment supplies output current
		Flashing: 0.5 s ON, 2.5 s OFF	The equipment is OFF or in stand-by
		Flashing (interval 1 s)	The CS PCB is faulty
D9	Green	ON	Circuit 1 is selected and the equipment supplies output current
		Flashing: 0.5 s ON, 2.5 s OFF	The equipment is OFF or in stand-by
		Flashing (interval 1 s)	The CS PCB is faulty
D10	Green	ON	Circuit 1 is selected and the equipment supplies output current
		Flashing: 0.5 s ON, 2.5 s OFF	The equipment is OFF or in stand-by
		Flashing (interval 1 s)	The CS PCB is faulty
D24	Green	ON	The CS and the equipment are ON
		Flashing: 0.5 s ON, 2.5 s OFF	The equipment is OFF
D25	Red	Flashing	The CS generates and alarm signal
D40	Green	Flashing	LRN - function

11.10 Test parameters

11.10.1 Analog channels

Table 32: Analog channels

Channel	Description	Value range
0	Temperature	17000 - 32000
1	Temperature	27000 - 32000
2	I bridge	100 - 2000
3	V bridge	0 - 30000
4	V in	±31000
5	Aux 1	x = 0
6	Aux 2	x = 0
Ref1	V reference 1	± 54000
Ref2	V reference 2	± 2800

11.10.2 Input

Table 33: Test input parameters

Connector	Function
PB0	Fan 1
PB1	If 1, the Precharge control switch is enabled
PB2	If 1, the Main control switch is enabled
PB3	Fan 2
PB4	If 0, SCO/panel is open
PB5	If 1, BUS fuse is not damaged
PF0	If 0, the overcurrent protection is ON
PF1	If 0, the overcurrent protection is ON

11.10.3 Output

Table 34: Test output parameters

Connector	Function
PE0	0 = Main control switch enabled
PE1	0 = Precharge control switch enabled
PE2	0 = Gate H activation
PE3	1 = Fan enabled
PE4	Display font
PE5	1 = Display back lighting ON
PE6	1 = Red fault LED ON
PE7	1 = Green power LED ON

11.10.4 External input

I0 to I15: Inputs from multiwire PCB.

11.10.5 External output

O0 to O15: Outputs from multiwire PCB.

11.10.6 PIC analog channels

Table 35: PIC analog channels test

Channel	Description
Div_I	Number of divisions of output current
Div_V	Number of divisions of output voltage
EFD	Number of divisions of EFD
Phase	Phase displacement between V and I (x 1000)

12.0 Wiring Diagram

Figure 36: CRE Wiring Diagram

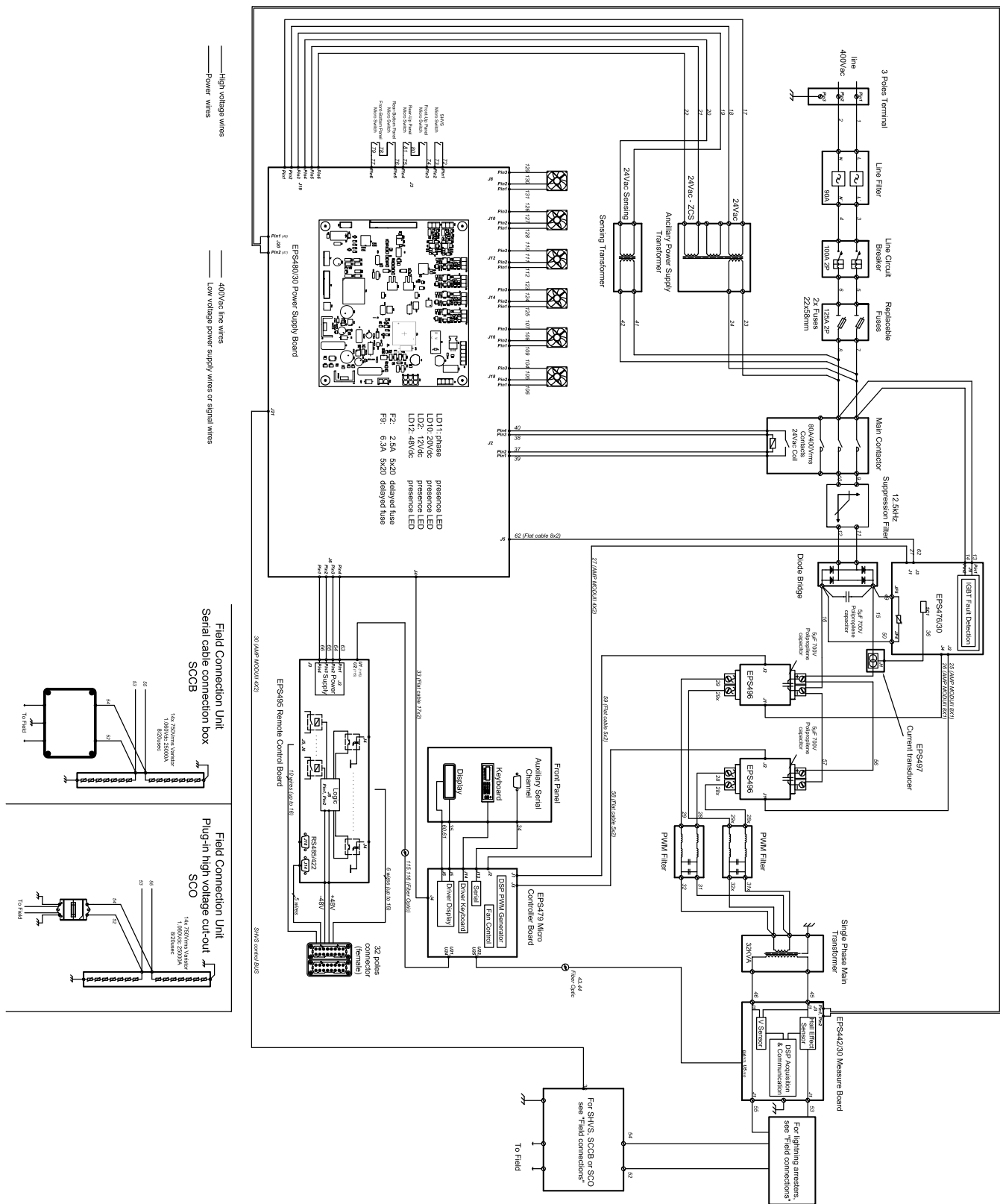

13.0 Technical Data

Table 36: Technical Specifications

Rated input voltage [V]	400 V AC ($\pm 10\%$) single phase 230 V AC ($\pm 10\%$) single phase
Rated frequencies [Hz]	50 or 60
Current regulation limits	Current regulation is guaranteed under the following conditions (± 0.1 A): <ul style="list-style-type: none"> Under IEC 61822:2009 environmental conditions For nominal input voltage under IEC or FAA standard conditions From full load to short circuit
Current regulation modes	Two preset regulation modes: <ul style="list-style-type: none"> normal mode (for linear loads) inductive mode (for non-linear loads (e.g. LED loads))
Average efficiency at full load	92 to 94% depending on the size of the equipment, under nominal resistive load, nominal output current, and nominal input voltage
Power factor at output	The power factor exceeds the IEC and FAA requirements. The power factor at rated load is close to 1 and is kept at a high level for possible operational conditions
Brightness steps	5 standard, 8 maximum, fully adjustable in 65k levels (1mA resolution)
Output current [A]	6.6
Remote control and monitoring	<ul style="list-style-type: none"> Multiwire: <ul style="list-style-type: none"> Compatible voltage: 24 VDC to 48 VDC for units without circuit selector; 24 VDC for units with circuit selector Internal power supply: 48 VDC for units without circuit selector; 24 VDC for units with circuit selector Single or dual J-Bus protocol over 2-wire RS485 Single or dual J-Bus protocol over Ethernet IEEE 802.3
Regulation response time	<ul style="list-style-type: none"> Less than 0.5 seconds Exceeds the requirements of IEC 61822:2009
Open circuit output voltage	Less than 1.2 times the nominal output voltage (RMS)
Enclosure protection	IP2X (according to IEC60529 and required by IEC61822) ¹ Object falling protection: Protected from objects falling vertically or at up to 5° from vertical (per IEC 62477-1)
OVC Rating	OVC II
Protective Class of the equipment	Class I

Table 37: Output specifications

Type	Rated output power [kW]	RMS output voltage at 6.6 A RMS output current [kV]	Insulated test on output ² [kV]	Output overvoltage protection 25kApk
CRE 2.5	2.5	0.38	3	0.75 kVRMS, 1.4 kJ
CRE 4.0	4.0	0.60	5	1.5 kVRMS, 2.8 kJ

¹The product is available with various IP ratings in addition to the standard IP2X, designed to suit diverse operational needs. Please note that certain options may affect the outline dimensions of the product. For more information or to discuss specific requirements, please contact your ADB SAFEGATE sales representative. Custom solutions are available upon request.

²Test condition: 50 Hz sinusoidal wave for 1 minute. The test is done without output overvoltage protections.

Table 37: Output specifications

Type	Rated output power [kW]	RMS output voltage at 6.6 A RMS output current [kV]	Insulated test on output [kV]	Output overvoltage protection 25kApk
CRE 5.0	5.0	0.75	5	1.5 kVRMS, 2.8 kJ
CRE 7.5	7.5	1.13	6	2.2 kVRMS, 4.2 kJ
CRE 10	10	1.50	10	2.2 kVRMS, 4.2 kJ
CRE 15	15	2.30	12	3.0 kVRMS, 5.6 kJ
CRE 20	20	3.03	15	4.5 kVRMS, 8.4 kJ
CRE 25	25	3.80	19	5.2 kVRMS, 9-8 kJ
CRE 30	30	4.54	23	6.0 kVRMS, 11.2 kJ

Table 38: Supply earthing systems and system voltage (V)

Supply earthing systems	System voltage
TN-S, TN-C, TN-CS, TT (not corner earthed)	≤ 230 V
TN-S, TT (corner earthed)	≤ 400 V
TN-C (middle point earthed)	≤ 200 V
IT (corner or not corner referenced)	≤ 230 V (TOV: 400 V)

Table 39: Prospective short-circuit current (PSCC) and residual current device (RCD)

	All power ratings
Max. PSCC	6kA
Min. PSCC	1500 A
RCD type	B

13.1 Applicable standards

The equipment is in accordance with these standards:

Standard	Description
ICAO	Aerodrome Design Manual, Part 5 paragraphs 3.2. (current edition)
FAA	AC 150/5345-10 (current edition), L-828 and L-829 except for input voltage
IEC	IEC 61822:2009
CENELEC	EN 61822
CE certified	

13.2 ElectroMagnetic Compatibility (EMC)

The equipment is designed to operate in an industrial electro-magnetic environment. The regulator complies with IEC 61822:2009, in accordance with IEC 61000-6-4 and IEC 6-6-2 (generic standard for industrial environment). The equipment is, with adapted test levels, in accordance with IEC/TS61000-6-5, G (substation environment, location G).

13.3 Dimensions and mass

Figure 37: The stackable cabinet (A), the small cabinet (B) and the big cabinet (C)

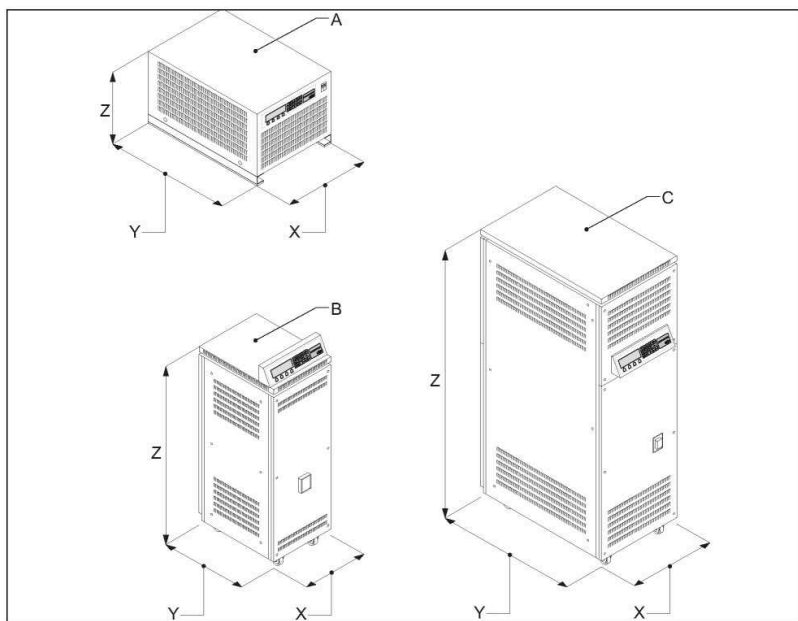

Table 40: Dimensions

Item	A - 2.5 kVA (stackable)	B - 2.5 kVA	B - 4 to 15 kVA	C - 20 to 30 kVA
X [mm]	420	420	420	520
Y [mm] ¹	800	550	840	840
Z [mm]	460	1300	1300	1600

Table 41: Mass

Type	Net mass	Crate mass	Crate dimensions width x depth x height [mm]
2.5 (rack)	95	20	600 x 1000 x 650
2.5	130	23	1200x800x1500
4	160	23	1200 x 800 x 1500
5	165	23	1200 x 800 x 1500
7.5	190	23	1200x800x 1500
10	230	23	1200 x 800 x 1500
15	260	23	1200 x 800 x 1500
20	330	40	1200 x 800 x 1850
25	380	40	1200 x 800 x 1850
30	410	40	1200 x 800 x 1850

¹ Depending on the type of series output connection (options).

13.4 Protection devices

Table 42: Protection devices specifications

Equipment type [kVA]	Equipment voltage [V]	Main fuse rating [A]	Manual switch type C rating [A]	Maximum line input current [A]
2.5	208 to 230	16	16	14.7
	380 to 400	16	10	8.0
4	208 to 230	32	25	23.4
	380 to 400	20	16	12.8
5	208 to 230	50	40	29.3
	380 to 400	32	20	16.0
7.5	208 to 230	50	50	44.0
	380 to 400	32	25	24.1
10	380 to 400	50	40	32.1
15	380 to 400	50	50	48.1
20	380 to 400	80	80	64.2
25	380 to 400	100	100	80.2
30	380 to 400	125	100	96.2

13.5 Used brightness steps

All equipments are programmed with five steps by default. You can change the number of required steps. [Table 43](#) shows the current values that the equipment produces at each step, depending on how many steps are programmed.

Example:

The equipment is set to five brightness steps. The default current value set for step 3 is 4.1 A.

Table 43: Current values produced at each brightness step

Brightness step	Default current value [A]					
	No. of steps used					
	3	4	5 (default)	6	7	8
1	4.8	3.3	2.8	2.7	2.2	2.8
2	5.5	4.4	3.4	3.4	2.8	3.1
3	6.6	5.5	4.1	3.9	3.4	3.4
4		6.6	5.2	4.5	4.1	3.9
5			6.6	5.4	5.2	4.6
6				6.6	6.4	5.5
7					6.6	6.4
8						6.6

These values apply when the minimum current is 2.8 A and the maximum current is 6.6 A.

13.6 Ambient conditions

The equipment is air-cooled with fans. Thus, the equipment must have a good airflow, especially if they operate near the maximum temperature. The installation environment shall be rated at maximum Pollution Degree 2 and free of vibrations.

Table 44: Ambient conditions

Temperature	From -20 °C up to +50 °C ¹
Storage temperature	From -40 °C up to +70°C
Temperature humidity for long-term storage	From 10% up to 95% RH without condensation
Altitude	From 0 (sea level) up to 2000 meters
Relative humidity	From 10% up to 95% RH without condensation
Relative humidity for long-term storage	< 60%

13.7 Parts list



WARNING

Use only original ADB SAFEGATE spare parts. If you use other spare parts, the specific module or the equipment may be damaged. This can also put personnel in danger.



Note

The parts list may be subject to change without prior notice. Contact ADB SAFEGATE to obtain the latest version.

Part orders

Each part of the equipment has a part number. When you order parts:

- Always mention the part number of the ordered part
- Always mention serial number and type of the equipment. These are indicated on the nameplate of the equipment.

For all spare part orders, contact ADB SAFEGATE or the local representative of ADB SAFEGATE.

Recommendations

To reduce downtime during maintenance, have one or more extra equipment cabinets in stand-by at the substation. This is especially important at major airports, which have a large amount of equipments.

Keep spare parts always in stock. For example:

- Fuses
- Lightning arrestors
- PCBs

13.7.1 Preventive spare parts

Item	Table
Main fuse	Table 45
Main contactor	Table 46
Lightning arrestors	Table 47

¹This product is certified and guaranteed to operate within a temperature range of 0°C to 50°C, as defined by IEC 61822:2009, IEC 62477-1, and IEC 61477-2. The product can also function within the temperature range of -20°C to +55°C ensuring that its core functionalities and behavior remain consistent with the ICAO Manual 5 requirements.

Item	Table
Overvoltage protection	Table 48
Capacitors	Table 49
Safety switches	Table 50
Fans	Table 51
IGBT bridge	Table 53
CPU PCB	Table 52
Output measure PCB	Table 54
Power supply PCB	Table 55
Remote control PCB	Table 56
Diode bridge PCB	Table 57
IGBT PCB	Table 58
Ethernet adapter	Table 59
Display and keyboard	Table 60

Table 45: Preventive spare parts - Main fuse

Description	Part number	New part number	Quantity per order														
			400 V										230 V				
			2.5	4	5	7.5	10	15	20	25	30	2.5 ST	2.5	4	5	7.5	
Fuse 16A 10X38 aM	6130.20.150	SP.011249	2											2	2		
Fuse 20A 10X38 aM	6130.20.160			2													
Fuse 32A 10x38 aM	6130.20.200	SP.011251			2	2										2	
Fuse 50A 14x51 aM	6130.20.210	SP.011252					2	2									2
Fuse 80A 22x58 aM	6130.20.280	SP.011254								2							
Fuse 100A 22x58 aM	6130.20.300											2					
Fuse 125A 22x58 aM	6130.20.220												2				

Table 46: Preventive spare parts - Main contactor

Description	Part number	Quantity per order															
		400 V										230 V					
		2.5	4	5	7.5	10	15	20	25	30	2.5 ST	2.5	4	5	7.5		
Contactor LC1D12B7	6148.46.030	1	1										1	1			
Contactor LC1D32B7	6148.46.000			1	1	1									1	1	
Contactor LC1D40B7	6148.46.010						1										1
Contactor LC1D80B7	6148.46.020							1	1	1							

Table 47: Preventive spare parts - Lightning arrestors

Description	Part number	New part number	Quantity per order													
			400 V						230 V							
			2.5	4	5	7.5	10	15	20	25	30	2.5 ST	4	5	7.5	
Lightning arrestor SIOV B72232-B751-K1	6314.32.750	SP.011369	2	4	4	4	6	8	10	12	14	2	2	4	4	4

Table 48: Preventive spare parts - Overvoltage protection

Description	Part number	New part number	Quantity per order													
			400 V						230 V							
			2.5	4	5	7.5	10	15	20	25	30	2.5 ST	4	5	7.5	
Overvoltage protection V480LA80BP	6314.12.286	SP.011368				1	1									

Table 49: Preventive spare parts - Capacitors

Description	Part number	New part number	Quantity per order													
			400 V						230 V							
			2.5	4	5	7.5	10	15	20	25	30	2.5 ST	4	5	7.5	
CAP. PPA1854100KN polypropylene film +	6322.60.240	SP.011373	2	2	2	2	2					2	2	2	2	2
CAP. RMB2104250KVR 2.5uF/1000V	6322.60.270							2	3	3	3					

Table 50: Preventive spare parts - Safety switches

Description	Part number	New part number	Quantity per order													
			400 V						230 V							
			2.5	4	5	7.5	10	15	20	25	30	2.5 ST	4	5	7.5	
Doorswitch EPS: 684	6150.49.060	SP.011297	3	3	3	3	3	3	20	4	4	4	3	3	3	3

Table 51: Preventive spare parts - Fans

Description	Part number	New part number	Quantity per order													
			400 V						230 V							
			2.5	4	5	7.5	10	15	20	25	30	2.5 ST	4	5	7.5	
CCR FAN 120x120x38 24VDC ball bearing	7074.10.100	SP.011436						2	6	6	6					

Table 52: Preventive spare parts - CPU PCB and CPU PCB with OVP

Description	Part number	New part number	Quantity per order														
			400 V						230 V								
			2.5	4	5	7.5	10	15	20	25	30	2.5 ST	4	5	7.5		
EPS479/5 CRE/VIS CPU pcb:CS00179 rev.1.1	1597.00.000		1	1	1	1							1	1	1	1	1
EPS479e/5 CRE/VIS CPU & OVP pcb:CS00179 rev.1.1	1597.00.030	SP.010668	1	1	1	1											
EPS479/15 CRE/VIS CPU pcb:CS00179 rev1.1	1597.00.010						1	1									
EPS479/15 CRE/VIS CPU & OVP pcb:CS00179 rev1.1	1597.00.040	SP.010669					1	1									
EPS479/30 CRE/VIS CPU pcb:CS00179 rev1.1	1597.00.020	SP1597.00.020									1	1	1				
EPS479/30 CRE/VIS CPU & OVP pcb:CS00179 rev1.1	1597.00.050	SP.010670									1	1	1				

Table 53: Preventive spare parts - IGBT bridge

Description	Part number	New part number	Quantity per order														
			400 V						230 V								
			2.5	4	5	7.5	10	15	20	25	30	2.5 ST	4	5	7.5		
Semix 202 GB 12E4s (IGBT)	6351.88.040	SP.011382	2	2	2	2	2	2					2	2	2	2	2
Semix 453 GB 12E4s (IGBT)	6351.88.060	SP.011383									2	2	2				
ISOLAT.M6 0.6kV	6126.12.485										2	2	2				
Semix 341D16s (Bridge Rectifier)	6351.88.030	SP.011381									1	1	1				

Table 54: Preventive spare parts - Output measure PCB

Description	Part number	New part number	Quantity per order														
			400 V						230 V								
			2.5	4	5	7.5	10	15	20	25	30	2.5 ST	4	5	7.5		
EPS442/2.5 CRE/VIS out.meas.board CS0039 rev.2.2	1597.00.100		1										1	1			
EPS442/5 CRE/VIS out.meas.board CS0039 rev.2.2	1597.00.110			1	1									1	1		
EPS442/7.5 CRE/VIS out.meas.board CS0039 rev.2.2	1597.00.120					1											1
EPS442/10 CRE/VIS out.meas.board CS0039 rev.2.2	1597.00.130						1										

Table 54: Preventive spare parts - Output measure PCB

Description	Part number	New part number	Quantity per order																
			400 V										230 V						
			2.5	4	5	7.5	10	15	20	25	30	2.5 ST	2.5	4	5	7.5			
EPS442/15 CRE/VIS out.meas.board CS0039 rev.2.2	1597.00.140							1											
EPS442/20 CRE/VIS out.meas.board CS0039 rev.2.2	1597.00.150	SP.010671								1									
EPS442/30 CRE/VIS out.meas.board CS0039 rev.2.2	1597.00.160											1	1						

Table 55: Preventive spare parts - Power supply PCB

Description	Part number	Quantity per order																	
		400 V										230 V							
		2.5	4	5	7.5	10	15	20	25	30	2.5 ST	2.5	4	5	7.5				
EPS480/30 VIS pow.sup.board PCB CS00180 rev.1.2 (6 fans, with SHVS)	1597.00.230		1	1	1	1	1	1	1	1	1	1	1	1	1	1	1	1	1

Table 56: Preventive spare parts - Remote control PCB

Description	Part number	New part number	Quantity per order																
			400 V										230 V						
			2.5	4	5	7.5	10	15	20	25	30	2.5 ST	2.5	4	5	7.5			
EPS495 CRE/VIS communication board PCB CS00190 rev. 1.2 ¹	1597.00.300	SP.010673	1	1	1	1	1	1	1	1	1	1	1	1	1	1	1	1	1
EP00047 Communication Board: Spares for Single or Dual JBUS RS485 or Single or Dual Ethernet CCRs ²	1597.00.310	SP.013108	1	1	1	1	1	1	1	1	1	1	1	1	1	1	1	1	1
EP00051 Communication Board add-on: Spares for Multiwire with or without Single or Dual JBUS RS485 or Single or Dual Ethernet CCRs ³	N/A	SP.013109	1	1	1	1	1	1	1	1	1	1	1	1	1	1	1	1	1
PCB1694 CRE EPS495 SIN (option CS)	1593.27.500		1	1	1	1	1	1	1	1	1	1	1	1	1	1	1	1	1

¹For CCRs made before September 2022.

²For CCRs made after September 2022.

³For CCRs made after September 2022.

Table 57: Preventive spare parts - Diode bridge PCB and diode bridge PCB with OVP

Description	Part number	New part number	Quantity per order													
			400 V						230 V							
			2.5	4	5	7.5	10	15	20	25	30	2.5 ST	2.5	4	5	7.5
EPS476/5 CRE2.5/ 7.5KVA PCB CS00176 rev.2.0 (diode bridge & sensing)	1597.00.401		1	1	1	1										
EPS476e/5 CRE2.5/ 7.5KVA PCB CS00176 rev.2.0 (diode bridge & sensing + OVP)	1597.00.402	SP.010674	1	1	1	1										
EPS476/5 CRE2.5KVA PCB CS00176 230V+ rev.V2.0 (diode bridge & sensing)	1597.00.460											1	1			
EPS507e CRE10/15KVA PCB CS00202 rev.1.2 (diode bridge & sensing + OVP)	1597.00.412	SP.010675				1	1									
EPS476/30 CRE/VIS 20/ 30KVA PCB CS00176 rev.2.0 (sensing, without diode bridge)	1597.00.421								1	1	1					
EPS476e/30 CRE/VIS 20/ 30KVA PCB CS00176 rev.2.0 (sensing, without diode bridge + OVP)	1597.00.422	SP.010676							1	1	1					
EPS476e/5/230 CRE2.5KVA PCB CS00176 230V+ rev.V2.0 (diode bridge & sensing + OVP)	1597.00.462											1	1			
EPS507 CRE4/7,5KVA PCB CS00202 230V+ rev,V1,2	1597.00.470													1	1	1
EPS507e/230 CRE4/ 7,5KVA PCB CS00202 230V+ rev.V1.2 (diode bridge & sensing + OVP)	1597.00.472													1	1	1

Table 58: Preventive spare parts - IGBT PCB

Description	Part number	New part number	Quantity per order													
			400 V						230 V							
			2.5	4	5	7.5	10	15	20	25	30	2.5 ST	2.5	4	5	7.5
EPS477 CRE/VIS 2.5/ 15KVA PCB CS00177 rev.1.1 (IGBT driver)	1597.00.510	SP.010681	2	2	2	2	2	2				2	2	2	2	2
EPS496 CRE/VIS 20/ 30KVA PCB CS00191 rev. 1.0 (IGBT driver)	1597.00.530	SP1597.00.530								2	2	2				
EPS478 CRE/VIS 2.5/ 15KVA PCB CS00178 rev.1.0 (connection board)	1597.00.520	SP.010682	1	1	1	1	1	1				1	1	1	1	1



Note

Depending on the communication configuration, the use of the new spares is possible with or without an upgrade kit. Contact ADB Safegate for more information.

Table 59: Preventive spare parts - Ethernet adapter

Description	Part number	Quantity per order													
		400 V										230 V			
		2.5	4	5	7.5	10	15	20	25	30	2.5 ST	2.5	4	5	7.5
EPS542 CRE/VIS single ethernet adapter PCB CS00230 rev.1.0	1597.00.600	1	1	1	1	1	1	1	1	1	1	1	1	1	1
EPS542 CRE/VIS double ethernet adapter PCB CS00230 rev.1.0	1597.00.610	1	1	1	1	1	1	1	1	1	1	1	1	1	1

Table 60: Preventive spare parts - Display and keyboard

Description	Part number	Quantity per order													
		400 V										230 V			
		2.5	4	5	7.5	10	15	20	25	30	2.5 ST	2.5	4	5	7.5
CCR Keyboard Box Assy. Monophase	4072.30.620	1	1	1	1	1	1	1	1	1		1	1	1	1

13.7.2 Corrective spare parts

Item	Table
Manual switch	Table 61
Main fuse housing	Table 62
Line filter	Table 63
Input filter	Table 64
Output filter	Table 65
Main transformer	Table 66

Table 61: Corrective spare parts - Manual switch

Description	Part number	Quantity per order													
		400 V										230 V			
		2.5	4	5	7.5	10	15	20	25	30	2.5 ST	2.5	4	5	7.5
S202-C10	6150.90.750	1													
S202-C16	6150.90.530		1							1	1				
S202-C20	6150.90.600			1											
S202-C25	6150.90.560				1								1		
S202-C40	6150.90.610					1									1

Table 61: Corrective spare parts - Manual switch

Description	Part number	Quantity per order														
		400 V										230 V				
		2.5	4	5	7.5	10	15	20	25	30	2.5	2.5	4	5	7.5	
		ST														
S202-C50	6150.90.580						1								1	
S292-C80	6150.90.630							1								
S292-C100	6150.90.640								1	1						

Table 62: Corrective spare parts - Main fuse housing

Description	Part number	Quantity per order														
		400 V										230 V				
		2.5	4	5	7.5	10	15	20	25	30	2.5	2.5	4	5	7.5	
		ST														
Fuse housing 32	6150.90.700		1	1	1	1							1	1	1	1
Fuse housing 50	6150.90.710						1	1								1
Fuse housing 125	6150.90.720								1	1	1					

Table 63: Corrective spare parts - Line filter

Description	Part number	New part number	Quantity per order														
			400 V										230 V				
			2.5	4	5	7.5	10	15	20	25	30	2.5	2.5	4	5	7.5	
			ST														
Line filter 284.003(1Ph 10A/ 400V)	6115.18.090	1															
MK1015 (1Ph 230V)	6115.18.120											1	1				
Line filter 284.001(1Ph 20A/ 400V)	6115.18.050			1	1												
Line filter 284.002(2Ph 40A/ 400V)	6115.18.060					1	1	1					1	1			
EMK1065 (1Ph 230V)	6115.18.130															1	
Line filter 284.004(2Ph 90A/ 400V)	6115.18.070								1	1	1						

Table 64: Corrective spare parts - Input filter

Description	Part number	New part number	Quantity per order														
			400 V										230 V				
			2.5	4	5	7.5	10	15	20	25	30	2.5	2.5	4	5	7.5	
			ST														
Toroidal inductor 750uH/15A	6166.50.350			1	1	1								1	1	1	1
Inductance 285uH/40A	6166.50.310	SP.011322					2	2	2	4	4	4					2

Table 64: Corrective spare parts - Input filter

Description	Part number	New part number	Quantity per order														
			400 V									230 V					
			2.5	4	5	7.5	10	15	20	25	30	2.5	2.5	4	5	7.5	
CAP. PMC1704500KVR 5uF/ 700V step 20-25+	6322.60.220	SP.011372	2	3	3	3	3						2	3	3	3	3
CAP. RMB2104250KVR 2.5uF/ 1000V	6322.60.270							8	8	8	8						

Table 65: Corrective spare parts - Output filter

Description	Part number	New part number	Quantity per order														
			400 V									230 V					
			2.5	4	5	7.5	10	15	20	25	30	2.5	2.5	4	5	7.5	
Toroidal inductor 750uH/15A	6166.50.350		2										2				
Inductance 285uH/40A	6166.50.310	SP.011322		2	2	2	2						2	2	2	2	
CAP. PMC1704500KVR 5uF/ 700V step 20-25+	6322.60.220	SP.011372	1														
Capacitor, 30uF 400V	6322.60.300	SP.011375		3	3	3	3	2	4	4	4	1					
Induct 150uH 100A - 20-25-30 kVA	6166.50.360								4	4	4						
Induct 300uH 50A - 15 kVA	6166.50.370								2								

Table 66: Corrective spare parts - Main transformer

Description	Part number	New part number	Quantity per order														
			400 V									230 V					
			2.5	4	5	7.5	10	15	20	25	30	2.5	2.5	4	5	7.5	
Transf.400Vac out:24V	6300.03.430	SP.011357	1	1	1	1	1	1	1	1	1						
Transf.100VA 400V/24V-	6300.03.400	SP6300.03.400	1	1	1	1	1	1									
Transf.200VA 400V/24V-6VA/ 24V-194VA	6300.03.410	SP6300.03.410							1	1	1						
Transf.100VA 230V/ 24V-94VA/24V-6VA	6300.03.420	SP6300.03.420											1	1	1	1	1
Transf. 6VA 230V/24V	6300.03.440												1	1	1	1	1

Table 67: Corrective spare parts - Hall sensor

Description	Part number	Quantity per order													
		400 V										230 V			
		2.5	4	5	7.5	10	15	20	25	30	2.5	2.5	4	5	7.5
Hall sensor old version ¹	1597.00.500							1	1	1					
Hall sensor new version ² big cabinet 20 to 30 kVa. Use from firmware version rel4.27e. PCB1628 CRE current sensor 200A	1593.21.000							1	1	1					

Table 68: Corrective spare parts - CS parts

Description	Part number	New part number	Quantity per order														
			400 V										230 V				
			2.5	4	5	7.5	10	15	20	25	30	2.5	2.5	4	5	7.5	
PCB1702 CSE-M SIN Logic MW	1593.28.300		1	1	1	1	1	1	1	1	1	1	1	1	1	1	1
DC-DC CONV. 18-36V/24VDC 15W SD-15B-24	6341.82.024		1	1	1	1	1	1	1	1	1	1	1	1	1	1	1
PSU 180-550VAC 24VDC 5A WDR-120-24	6341.80.240		1	1	1	1	1	1	1	1	1	1	1	1	1	1	1
Surge arrester cartridge L1-PE 230V IT	6134.03.080	SP.011278	2	2	2	2	2	2	2	2	2	2	2	2	2	2	2
Relay Gigavac G81AB47 code Epsilon 7784	6169.07.100		Depends on the number of series circuits														
RELC CSE-M	1593.20.200		Depends on the number of series circuits														
PCB1703 CSE-M HMI SIN	1593.28.400		1	1	1	1	1	1	1	1	1	1	1	1	1	1	1

¹Shape: square Location: connected to the sensing PCB

²Shape and location: see

Appendix A: Support

Our experienced engineers are available for support and service at all times, 24 hour/7 days a week. They are part of a dynamic organization making sure the entire ADB SAFEGATE is committed to minimal disturbance for airport operations.

ADB SAFEGATE Support

Technical Support – Global

Customers in Europe, the Middle East, Africa and Asia Pacific are more than welcome to our portal for technical support. Trained in all areas of system issues, troubleshooting, quality control and technical assistance, our highly experienced Technical support specialists are available 24 hours a day, seven days a week to provide assistance over the phone.

Europe: **+32-2-722-17-11**

China: **+86-10-8476-0106**

Middle East and Africa: **+971-4-452-7575**

In the Americas, we also offer live technical support.

Live Technical Support – Americas

If at any time you have a question or concern about your product, contact ADB SAFEGATE's US-based technical support specialists, available 24 hours a day, seven days a week, to assist you via phone.

ADB SAFEGATE Americas Technical Service & Support (US & Canada) :**+1-800-545-4157**

ADB SAFEGATE Americas Technical Service & Support (Canada): **+1-905-631-1597**

ADB SAFEGATE Americas Technical Service & Support (International): **+1-614-861-1304**. For technical service press 3 and for sales support press 4.

We can also be reached via email during regular business hours.

Airfield and Gate: **techservice.us@adbsafegate.com**

Gate: **gateservice.us@adbsafegate.com**

We look forward to working with you!

Before You Call

When you have an airfield lighting or control system problem, prior to calling, please ensure the following:

- Review the product's manual and troubleshooting guide.
- Be located with the product ready to troubleshoot.
- Have all necessary information available: airport code/company name, customer id number, contact phone number/email address, product/part number.
- Have all necessary tools that may be needed at hand.

When calling about an issue with Safedock A-VDGS, we can serve you better if you collect the following information before you call:

- Relevant information regarding the issue you are calling about, such as gate number, flight number, aircraft type and time of the event.
- What, if any, actions have been taken to resolve the issue prior to the call.
- If available, provide a CCTV recording of the incident to aid in aligning the information from the Safedock log file.

For more information, see www.adbsafegate.com, contact ADB SAFEGATE Support via email at **support@adbsafegate.com**.

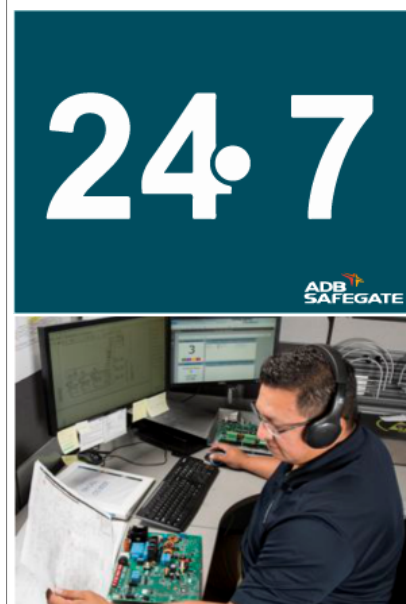

A.1 ADB SAFEGATE Website

The ADB SAFEGATE website, www.adbsafegate.com, offers information regarding our airport solutions, products, company, news, links, downloads, references, contacts and more.

A.2 Recycling

A.2.1 ADB SAFEGATE Recycling

ADB SAFEGATE is fully committed to environmentally-conscious manufacturing with strict monitoring of our own processes as well as supplier components and sub-contractor operations. ADB SAFEGATE offers a recycling program for our products to all customers worldwide, whether or not the products were sold within the European Union (EU).

ADB SAFEGATE products and/or specific electrical and electronic component parts which are fully removed/separated from any customer equipment and returned will be accepted for our recycling program.

All items returned must be clearly labeled as follows:

- For Restriction of Hazardous Substances (RoHS)/Waste Electrical and Electronic Equipment (WEEE) Recycling
- Sender contact information (Name, Business Address, Phone number).
- Main Unit Serial Number.

ADB SAFEGATE will continue to monitor and update according for any future requirements for EU directives as and when EU member states implement new regulations and or amendments. It is our aim to maintain our compliance plan and assist our customers.

A.2.1.1 Local Authority Recycling

The disposal of ADB SAFEGATE products is to be made at an applicable collection point for the recycling of electrical and electronic equipment. The correct disposal of equipment prevents any potential negative consequences for the environment and human health, which could otherwise be caused by inappropriate waste handling. The recycling of materials helps to conserve natural resources. For more detailed information about recycling of products, contact your local authority city office.

WWW.ADBSAFEGATE.COM

Empowering the Airside **Evolution**

SMARTER. BETTER. **NOW.**



Copyright ©2023—2026 ADB SAFEGATE, All Rights Reserved