



Constant Current Regulator
Type VIS

Installation Manual

6009, Rev. 2.1, 2024/07/17

**ADB
SAFEGATE**

A.0 Disclaimer / Standard Warranty

CE certification

The equipment listed as CE certified means that the product complies with the essential requirements concerning safety and hygiene. The European directives that have been taken into consideration in the design are available on written request to ADB SAFEGATE.

ETL certification

The equipment listed as ETL certified means that the product complies with the essential requirements concerning safety and C22.2 No.180:13 (R2018) regulations. The CSA directives that have been taken into consideration in the design are available on written request to ADB SAFEGATE.

All Products Guarantee

ADB SAFEGATE will correct by repair or replacement per the applicable guarantee below, at its option, equipment or parts which fail because of mechanical, electrical or physical defects, provided that the goods have been properly handled and stored prior to installation, properly installed and properly operated after installation, and provided further that Buyer gives ADB SAFEGATE written notice of such defects after delivery of the goods to Buyer. Refer to the Safety section for more information on Material Handling Precautions and Storage precautions that must be followed.

ADB SAFEGATE reserves the right to examine goods upon which a claim is made. Said goods must be presented in the same condition as when the defect therein was discovered. ADB SAFEGATE further reserves the right to require the return of such goods to establish any claim.

ADB SAFEGATE's obligation under this guarantee is limited to making repair or replacement within a reasonable time after receipt of such written notice and does not include any other costs such as the cost of removal of defective part, installation of repaired product, labor or consequential damages of any kind, the exclusive remedy being to require such new parts to be furnished.

ADB SAFEGATE's liability under no circumstances will exceed the contract price of goods claimed to be defective. Any returns under this guarantee are to be on a transportation charges prepaid basis. For products not manufactured by, but sold by ADB SAFEGATE, warranty is limited to that extended by the original manufacturer. This is ADB SAFEGATE's sole guarantee and warranty with respect to the goods; there are no express warranties or warranties of fitness for any particular purpose or any implied warranties of fitness for any particular purpose or any implied warranties other than those made expressly herein. All such warranties being expressly disclaimed.

Standard Products Guarantee

Products manufactured by ADB SAFEGATE are guaranteed against mechanical, electrical, and physical defects (excluding lamps) which may occur during proper and normal use for a period of two years from the date of ex-works delivery, and are guaranteed to be merchantable and fit for the ordinary purposes for which such products are made.



Note

See your applicable sales agreement for a complete warranty description.

Replaced or repaired equipment under warranty falls into the warranty of the original delivery. No new warranty period is started for these replaced or repaired products.

FAA Certified products manufactured by ADB SAFEGATE

ADB SAFEGATE L858 Airfield Guidance Signs are warranted against mechanical and physical defects in design or manufacture for a period of 2 years from date of installation, per FAA AC 150/5345-44 (applicable edition).

ADB SAFEGATE LED products (with the exception of obstruction lighting) are warranted against electrical defects in design or manufacture of the LED or LED specific circuitry for a period of 4 years from date of installation, per FAA EB67 (applicable edition). These FAA certified constant current (series) powered LED products must be installed, interfaced and powered with and through products certified under the FAA Airfield Lighting Equipment Program (ALECP) to be included in this 4 (four) year warranty. This includes, but is not limited to, interface with products such as Base Cans, Isolation Transformers, Connectors, Wiring, and Constant Current Regulators.



Note

See your sales order contract for a complete warranty description.

Replaced or repaired equipment under warranty falls into the warranty of the original delivery. No new warranty period is started for these replaced or repaired products.

Liability



WARNING

Use of the equipment in ways other than described in the catalog leaflet and the manual may result in personal injury, death, or property and equipment damage. Use this equipment only as described in the manual.

ADB SAFEGATE cannot be held responsible for injuries or damages resulting from non-standard, unintended uses of its equipment. The equipment is designed and intended only for the purpose described in the manual. Uses not described in the manual are considered unintended uses and may result in serious personal injury, death or property damage.

Unintended uses, includes the following actions:

- Making changes to equipment that have not been recommended or described in this manual or using parts that are not genuine ADB SAFEGATE replacement parts or accessories.
- Failing to make sure that auxiliary equipment complies with approval agency requirements, local codes, and all applicable safety standards if not in contradiction with the general rules.
- Using materials or auxiliary equipment that are inappropriate or incompatible with your ADB SAFEGATE equipment.
- Allowing unskilled personnel to perform any task on or with the equipment.

Copyright Statement

This manual or parts thereof may not be reproduced, stored in a retrieval system, or transmitted, in any form or by any means, electronic, mechanical, photocopying, recording, nor otherwise, without the author's prior written consent.

This manual could contain technical inaccuracies or typographical errors. The author reserves the right to revise this manual from time to time in the contents thereof without obligation of the author to notify any person of such revision or change. Details and values given in this manual are average values and have been compiled with care. They are not binding, however, and the author disclaims any liability for damages or detriments suffered as a result of reliance on the information given herein or the use of products, processes or equipment to which this manual refers. No warranty is made that the use of the information or of the products, processes or equipment to which this manual refers will not infringe any third party's patents or rights. The information given does not release the buyer from making their own experiments and tests.

TABLE OF CONTENTS

1.0 Safety	1
1.1 Safety Messages	1
1.1.1 Introduction to Safety	2
1.1.2 Intended Use	2
1.1.3 Material Handling Precautions: Storage	3
1.1.4 Operation Safety	3
1.1.5 Maintenance Safety	3
1.1.6 Material Handling Precautions, ESD	4
2.0 Description	5
2.1 Intended Use	5
2.2 Working Principle	6
2.3 Layout of the Equipment Cabinet	8
2.3.1 Outside - small cabinet: 2.5 to 15 kVA	8
2.3.2 Inside - small cabinet: 2.5 to 15 kVA	8
2.3.3 Outside - big cabinet 20 to 30 kVA	10
2.3.4 Inside - big cabinet 20 to 30 kVa	11
2.4 Components	11
2.4.1 Line input	12
2.4.2 IGBT power bridge	16
2.4.3 Capacitor bank	18
2.4.4 Hall sensor, big cabinet	18
2.4.5 Output filter	19
2.4.6 Main transformer, all cabinets	19
2.4.7 Output measure PCB (EPS422), all cabinets	20
2.4.8 Power output	20
2.5 Options	23
2.5.1 Remote control	23
2.5.2 Ethernet PCB (EPS542), all cabinets	23
2.5.3 Circuit selector (CS)	23
2.5.4 Lightning arrestors (option CS)	24
2.5.5 Interface PCB (PCB1702) (option CS)	24
2.5.6 CS PCB (PCB1619) (option CS)	24
2.5.7 HMI SIN PCB (PCB1703) (option CS)	25
2.5.8 Remote control SIN PCB (PCB1694) (option CS)	25
2.5.9 CS relay (option CS)	26
2.5.10 Current sensor (option CS)	26
2.5.11 Series Connector Box (SCB), all cabinets	26
2.5.12 Series CutOut (SCO), all cabinets	27
2.5.13 Rolling castors	27
2.6 HMI	27
2.7 HMI of an equipment with CS (option CS)	27
2.8 Nameplate	28
3.0 Inspection, Transportation and Storage	29
3.1 Inspect equipment on delivery	29
3.2 Transport and unpack the crate	29
3.3 Transport Unpacked Equipment	29
3.4 Storage	31
4.0 Pre-Installation	33
4.1 How to pre-install - general procedure	33
4.2 Prepare Substation	33
4.2.1 Provide heat dissipation	34
4.2.2 Ventilation	35
4.3 Prepare lightning protection	36

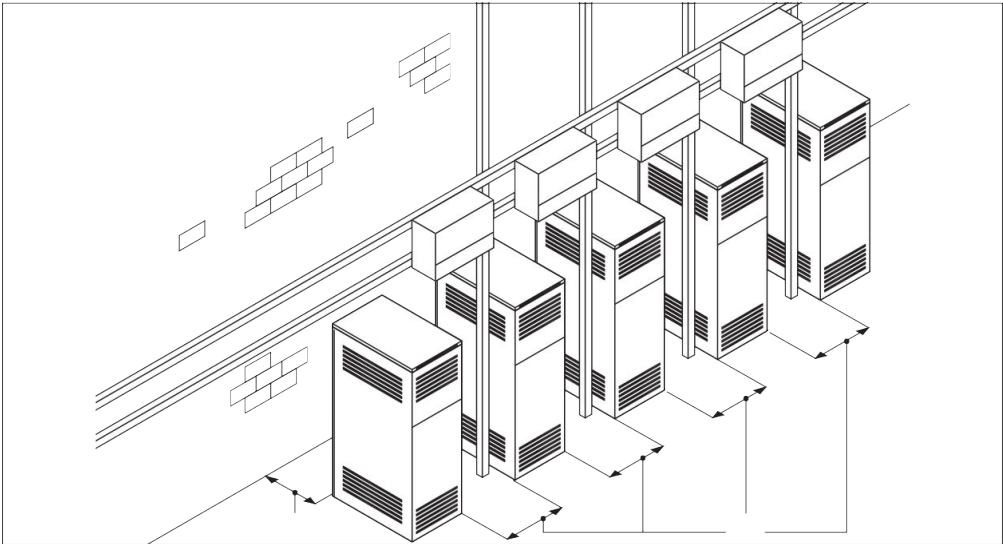
4.4 Install power supply	36
4.5 Plan cables and lay-out of cables	36
4.5.1 Plan cables to remote control interface	37
5.0 Installation	41
5.1 Required tools and equipment	42
5.2 Inspection	42
5.3 Remove lower rear panel, big and small cabinet	43
5.4 Switch OFF the power supply	44
5.5 Install additional earthing, big and small cabinet	44
5.6 Connect power input supply	44
5.7 Connect Output to Series Circuit	45
5.7.1 Connect Output to Series Circuit with SCB	46
5.7.2 Connect Output to Series Circuit with SCO	47
5.8 Connect Remote Control Cables	50
5.9 Install Lower Rear Panel	51
6.0 Technical Data	53
6.1 Applicable standards	54
6.2 ElectroMagnetic Compatibility (EMC)	54
6.3 Ambient conditions	54
6.4 Dimensions and mass	55
6.5 	56
6.5.1 layout, big and small cabinets	56
6.6 Protection devices	56
6.7 Remote Control PCB	57
6.7.1 EPS495 (1597.00.300)	57
6.7.2 EP00047 and EP00051	59
6.7.3 Multiwire/J-Bus connection scheme	60
A.0 SUPPORT	65
A.1 ADB SAFEGATE Website	66
A.2 Recycling	66
A.2.1 ADB SAFEGATE Recycling	66

List of Figures

Figure 1: Series circuit system overview	5
Figure 2: Input terminal, all cabinets	12
Figure 3: Line filter, all cabinets	12
Figure 4: Manual switch, all cabinets	12
Figure 5: Main fuses, small cabinet	13
Figure 6: Main fuses, big cabinet	13
Figure 7: Main contactor, small cabinet	13
Figure 8: Main contactor, big cabinet	13
Figure 9: Precharge contactor, small cabinet	14
Figure 10: Precharge contactor, big cabinet	14
Figure 11: Precharge PCB (EPS456), all cabinets	14
Figure 12: Sensing transformer, all cabinets	14
Figure 13: Power supply transformer, all cabinets	15
Figure 14: Diode bridge + sensing PCB (EPS540 / EPS541), small cabinet	16
Figure 15: Sensing PCB (EPS497), big cabinet	16
Figure 16: Diode bridge, big cabinet	17
Figure 17: IGBT, all cabinets	17
Figure 18: IGBT PCB (EPS477 /EPS496 /EPS 478), all cabinets	17
Figure 19: Capacitor bank, small cabinet	18
Figure 20: Capacitor bank, big cabinet	18
Figure 21: Hall sensor, big cabinet	18
Figure 22: Output filter, small cabinet	19
Figure 23: Output filter, big cabinet	19
Figure 24: Remove panel	43
Figure 25: Disconnect wires	43
Figure 26: The small cabinet (A) and the big cabinet (B)	55
Figure 27: Printed Circuit Board (PCB)	57
Figure 28: Printed Circuit Board (PCB)	59
Figure 29: Multiwire and J-Bus connection	63

List of Tables

Table 1: Indicative values for heat dissipation	34
Table 2: Recommended multiwire cables	38
Table 3: Wire sections and cable lengths for multiwire cables	38
Table 4: Wire sections for J-Bus cables	38
Table 5: Pre-installation checklist	41
Table 6: Technical Specifications	53
Table 7: Output specifications	53
Table 8: Ambient conditions	54
Table 9: Dimensions	55
Table 10: Mass	55
Table 11: Protection devices specifications	56
Table 12: Remote control PCB LED functions	57
Table 13: Remote control PCB jumper settings	57
Table 14: Factory set terminal assignments for remote control connections with multiwire and single J-Bus (Cable Set 4072.30.XXX)	60
Table 15: Factory set terminal assignments for remote control connections with multiwire dual J-Bus (Cable Set 4072.30.182)	61

1.0 Safety

Introduction to Safety

This section contains general safety instructions for installing and using ADB SAFEGATE equipment. Some safety instructions may not apply to the equipment in this manual. Task- and equipment-specific warnings are included in other sections of this manual where appropriate.

1.1 Safety Messages

HAZARD Icons used in the manual

For all HAZARD symbols in use, see the Safety section. All symbols must comply with ISO and ANSI standards.

Carefully read and observe all safety instructions in this manual, which alert you to safety hazards and conditions that may result in personal injury, death or property and equipment damage and are accompanied by the symbol shown below.



WARNING
Failure to observe a warning may result in personal injury, death or equipment damage.



DANGER - Risk of electrical shock or ARC FLASH
Disconnect equipment from line voltage. Failure to observe this warning may result in personal injury, death, or equipment damage. ARC Flash may cause blindness, severe burns or death.



WARNING - Wear personal protective equipment
Failure to observe may result in serious injury.



WARNING - Do not touch
Failure to observe this warning may result in personal injury, death, or equipment damage.



CAUTION
Failure to observe a caution may result in equipment damage.



ELECTROSTATIC SENSITIVE DEVICES
This equipment may contain electrostatic devices.

Qualified Personnel



Important Information

The term **qualified personnel** is defined here as individuals who thoroughly understand the equipment and its safe operation, maintenance and repair. Qualified personnel are physically capable of performing the required tasks, familiar with all relevant safety rules and regulations and have been trained to safely install, operate, maintain and repair the equipment. It is the responsibility of the company operating this equipment to ensure that its personnel meet these requirements.

Always use required personal protective equipment (PPE) and follow safe electrical work practice.

1.1.1 Introduction to Safety



CAUTION

Unsafe Equipment Use

This equipment may contain electrostatic devices, hazardous voltages and sharp edges on components

- Read installation instructions in their entirety before starting installation.
- Become familiar with the general safety instructions in this section of the manual before installing, operating, maintaining or repairing this equipment.
- Read and carefully follow the instructions throughout this manual for performing specific tasks and working with specific equipment.
- Make this manual available to personnel installing, operating, maintaining or repairing this equipment.
- Follow all applicable safety procedures required by your company, industry standards and government or other regulatory agencies.
- Install all electrical connections to local code.
- Use only electrical wire of sufficient gauge and insulation to handle the rated current demand. All wiring must meet local codes.
- Route electrical wiring along a protected path. Make sure they will not be damaged by moving equipment.
- Protect components from damage, wear, and harsh environment conditions.
- Allow ample room for maintenance, panel accessibility, and cover removal.
- Protect equipment with safety devices as specified by applicable safety regulations
- If safety devices must be removed for installation, install them immediately after the work is completed and check them for proper functioning prior to returning power to the circuit.

Failure to follow this instruction can result in serious injury or equipment damage

Additional Reference Materials



Important Information

- IEC - International Standards and Conformity Assessment for all electrical, electronic and related technologies.
- IEC 60364 - Electrical Installations in Buildings.
- CSA - C22.2 No.180:13 (R2018) Series isolating transformers for airport lighting
- FAA Advisory: AC 150/5340-26 (current edition), Maintenance of Airport Visual Aid Facilities.
- Maintenance personnel must refer to the maintenance procedure described in the ICAO Airport Services Manual, Part 9.
- ANSI/NFPA 79, Electrical Standards for Metalworking Machine Tools.
- National and local electrical codes and standards.

1.1.2 Intended Use



CAUTION

Use this equipment as intended by the manufacturer

This equipment is designed to perform a specific function, do not use this equipment for other purposes

- Using this equipment in ways other than described in this manual may result in personal injury, death or property and equipment damage. Use this equipment only as described in this manual.

Failure to follow this instruction can result in serious injury or equipment damage

1.1.3 Material Handling Precautions: Storage



CAUTION

Improper Storage

Store this equipment properly

- If equipment is to be stored prior to installation, it must be protected from the weather and kept free of condensation and dust.

Failure to follow this instruction can result in equipment damage

1.1.4 Operation Safety



CAUTION

Improper Operation

Do Not Operate this equipment other than as specified by the manufacturer

- Only qualified personnel, physically capable of operating the equipment and with no impairments in their judgment or reaction times, should operate this equipment.
- Read all system component manuals before operating this equipment. A thorough understanding of system components and their operation will help you operate the system safely and efficiently.
- Before starting this equipment, check all safety interlocks, fire-detection systems, and protective devices such as panels and covers. Make sure all devices are fully functional. Do not operate the system if these devices are not working properly. Do not deactivate or bypass automatic safety interlocks or locked-out electrical disconnects or pneumatic valves.
- Protect equipment with safety devices as specified by applicable safety regulations.
- If safety devices must be removed for installation, install them immediately after the work is completed and check them for proper functioning.
- Route electrical wiring along a protected path. Make sure they will not be damaged by moving equipment.
- Never operate equipment with a known malfunction.
- Do not attempt to operate or service electrical equipment if standing water is present.
- Use this equipment only in the environments for which it is rated. Do not operate this equipment in humid, flammable, or explosive environments unless it has been rated for safe operation in these environments.
- Never touch exposed electrical connections on equipment while the power is ON.

Failure to follow these instructions can result in equipment damage

1.1.5 Maintenance Safety



DANGER

Electric Shock Hazard

This equipment may contain electrostatic devices

- Do not operate a system that contains malfunctioning components. If a component malfunctions, turn the system OFF immediately.
- Disconnect and lock out electrical power.
- Allow only qualified personnel to make repairs. Repair or replace the malfunctioning component according to instructions provided in its manual.

Failure to follow these instructions can result in death or equipment damage

1.1.6 Material Handling Precautions, ESD



CAUTION

Electrostatic Sensitive Devices

This equipment may contain electrostatic devices

- Protect from electrostatic discharge.
- Electronic modules and components should be touched only when this is unavoidable e.g. soldering, replacement.
- Before touching any component of the cabinet you shall bring your body to the same potential as the cabinet by touching a conductive earthed part of the cabinet.
- Electronic modules or components must not be brought in contact with highly insulating materials such as plastic sheets, synthetic fiber clothing. They must be laid down on conductive surfaces.
- The tip of the soldering iron must be grounded.
- Electronic modules and components must be stored and transported in conductive packing.

Failure to follow this instruction can result in equipment damage

2.0 Description

Figure 1: Series circuit system overview

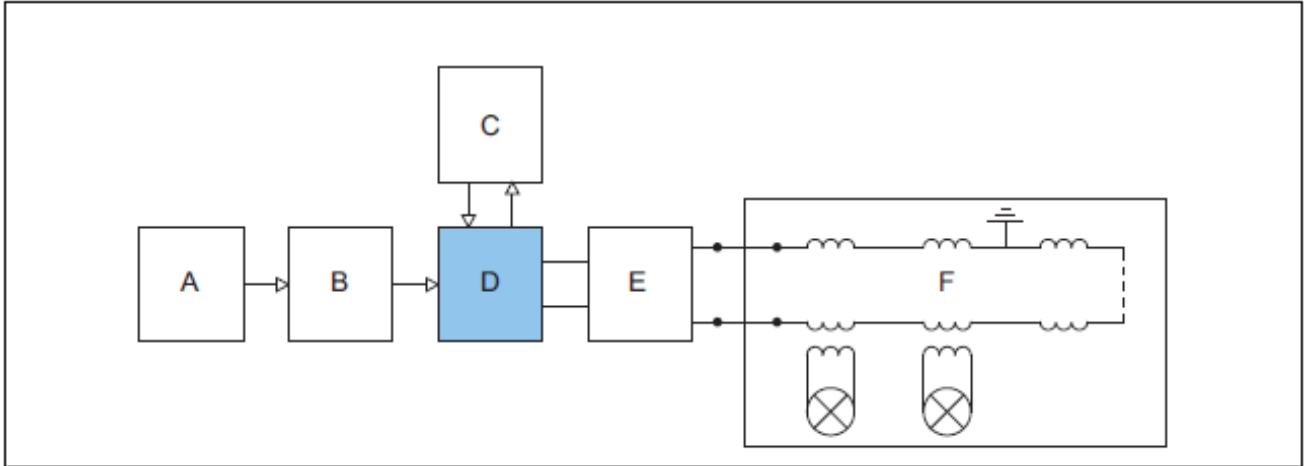

A Input power supply
 B Manual switch
 C Remote control system

D Equipment
 E Output disconnection device (optional)
 F Series circuit

The equipment is a microprocessor-controlled Constant Current Regulator with an optional output disconnection device (circuit selector).

2.1 Intended Use

The equipment is designed to convert an AC sine wave input voltage into an adjusted output current selected in brightness steps to supply a series AGL circuit.

Any other or additional use will not be considered to be in conformity with the purpose.

Do not operate the equipment outside the limits of the specifications or outside the specified ambient conditions.

2.2 Working Principle

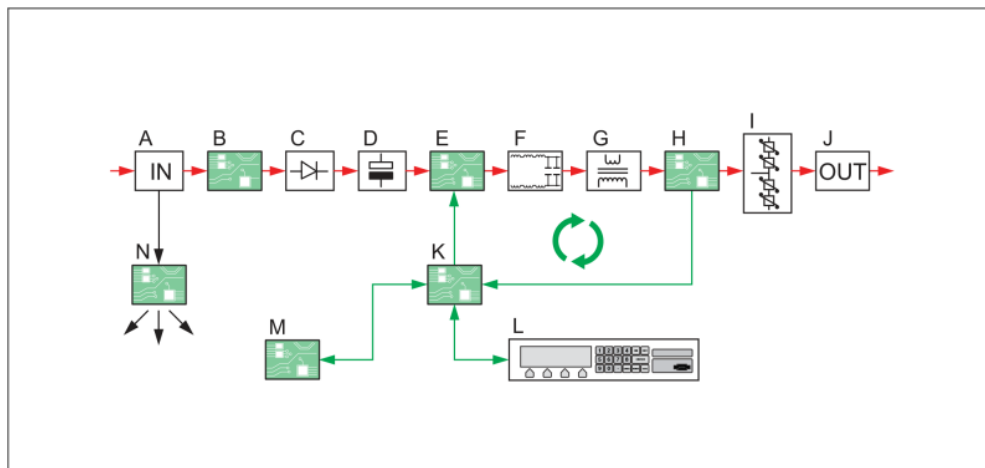
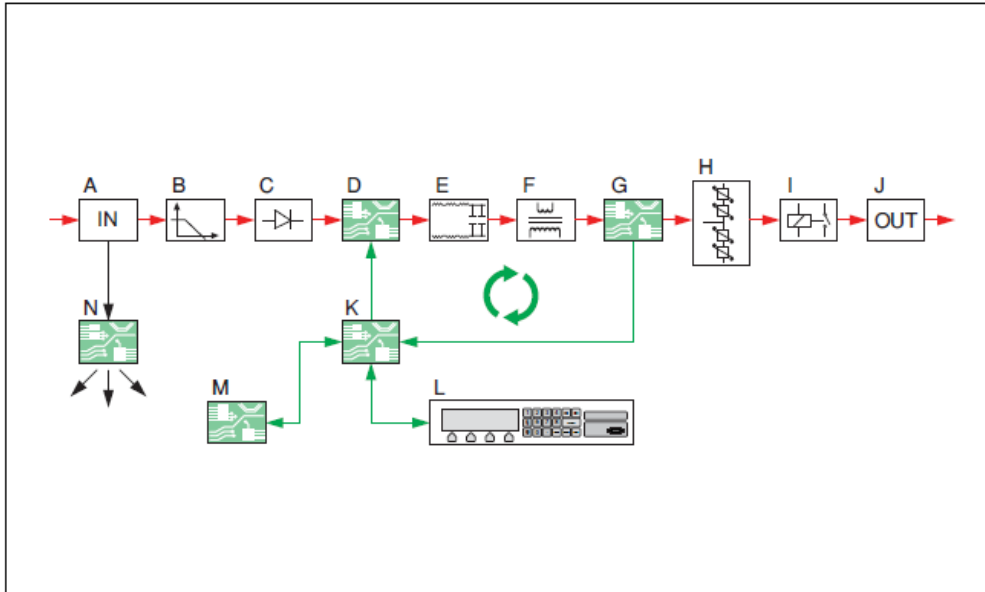

A	Line input. See Line input
B	Precharge PCB. See Line input
C	Diode bridge and sensing PCB. See IGBT power bridge
D	Capacitor bank. See Capacitor bank
E	IGBT module and IGBT PCB. See IGBT power bridge
F	Output filter. See Output filter
G	Main transformer. See Main transformer, all cabinets
H	Output measure PCB. See Output measure PCB (EPS422), all cabinets
I	Lightning arrestors. See Power output
J	Series output connection. See Power output
K	CPU PCB. See CPU PCB (EPS479), all cabinets

L	HMI. See HMI
M	Remote control PCB. See Remote control PCB (EPS495 or EP00047) , all cabinets
N	Power supply PCB. See Power supply PCB (EPS480) , all cabinets

Legend

- Red lines: current
- Green lines: signal wires connections
- Black lines: low voltage connections

Current regulation

The equipment converts the single phase input voltage line into a rectified current and voltage. The equipment then converts this DC current and voltage into a pure sine wave with a defined power rating.

Main feedback loop

The output measure PCB sends the measured output to the CPU PCB. Depending on the output, the CPU PCB automatically generates a signal to adjust the regulation.

2.3 Layout of the Equipment Cabinet

2.3.1 Outside - small cabinet: 2.5 to 15 kVA

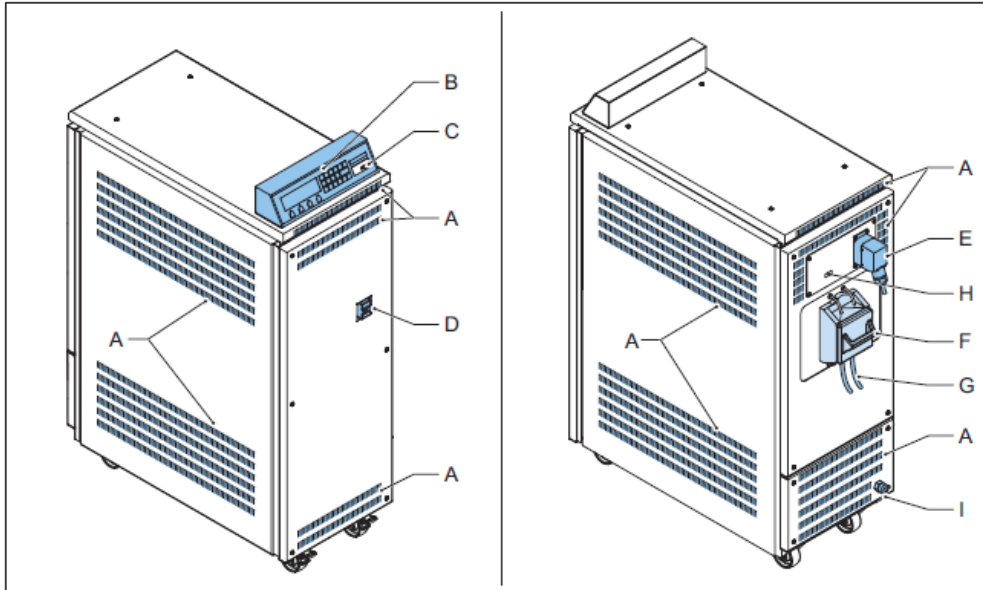

A	Ventilation grids
B	HMI
C	Serial communication port
D	Manual switch
E	Remote control connector
F	Series output connection. The illustration shows the SCO
G	Output to Series Circuit
H	Ethernet connector
I	Power supply cable entry

2.3.2 Inside - small cabinet: 2.5 to 15 kVA

i Note

The illustrations show the 10 kVA cabinet.

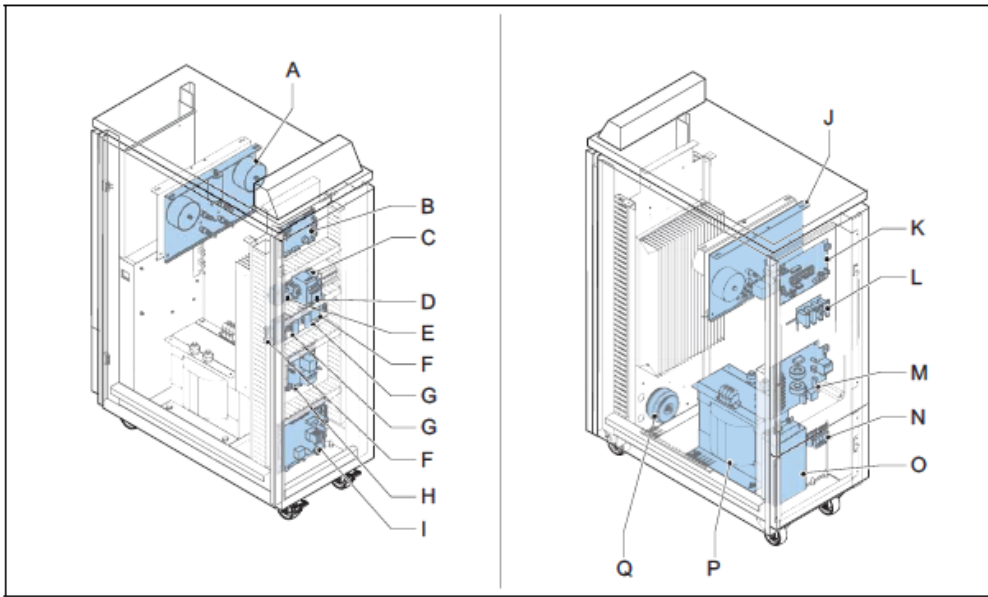

A	Output filter
B	CPU PCB
C	Main fuses
D	Main contactor
E	Sensing transformer
F	IGBT
G	IGBT PCB (EPS477)
H	Diode bridge and sensing PCB (EPS476 / EPS507)
I	Power supply PCB (EPS480)
J	Input filter
K	Remote control PCB (EPS495 or EP00047)
L	Lightning arrestors
M	Output measure PCB (EPS442)
N	Input terminals
O	Line filter
P	Main transformer
Q	Power supply transformer

2.3.3 Outside - big cabinet 20 to 30 kVA

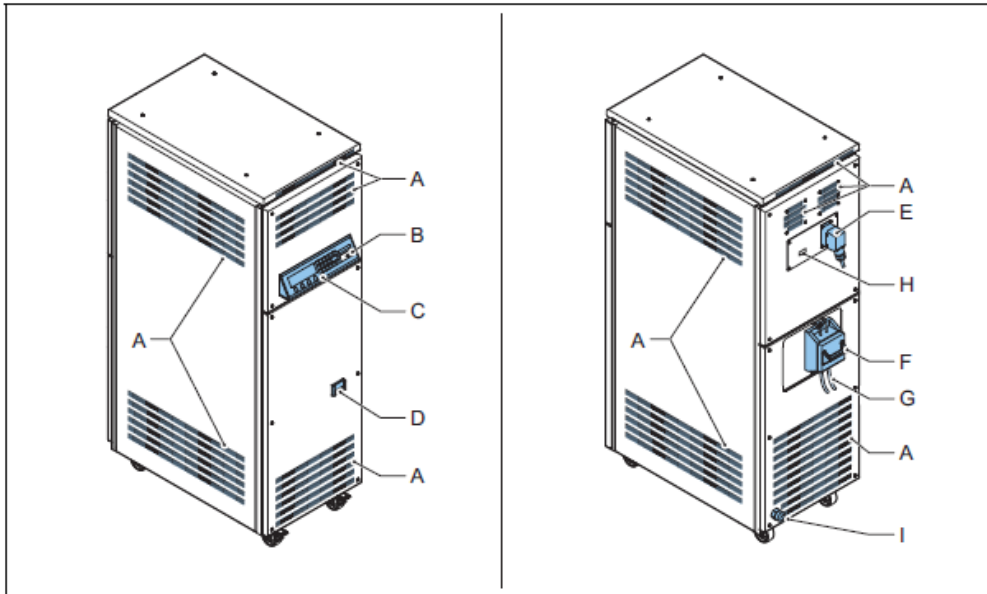

A	Ventilation grids
B	HMI
C	Serial communication port
D	Manual switch
E	Remote control connector
F	Series output connection. The illustration shows the SCO
G	Output to Series Circuit
H	Ethernet connector
I	Power supply cable entry

2.3.4 Inside - big cabinet 20 to 30 kVa

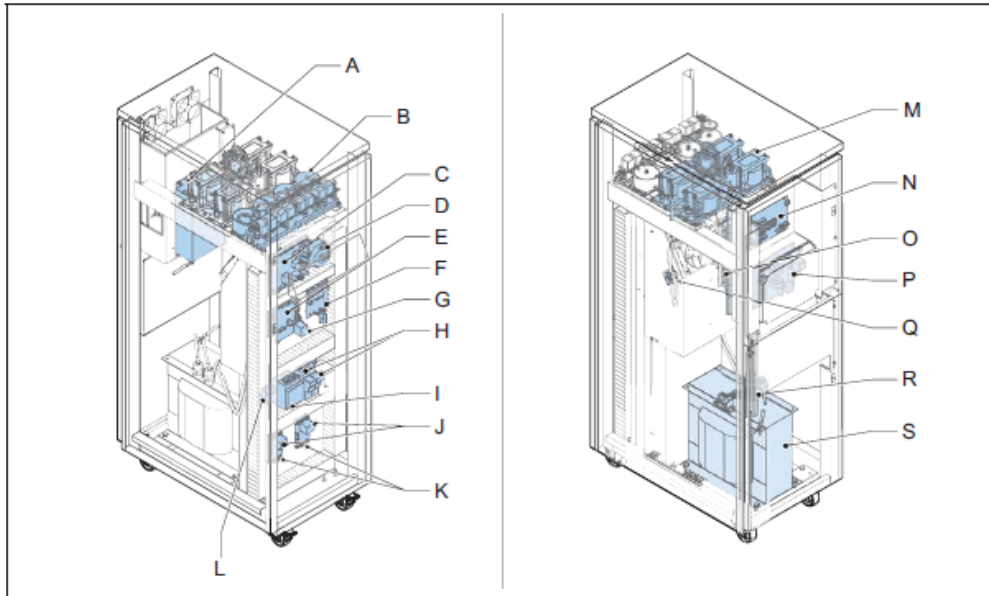

A	Line filter
B	Input filter
C	Power supply PCB (EPS480)
D	Power supply transformer
E	CPU PCB (EPS479)
F	Sensing PCB (EPS476)
G	Diode Bridge
H	Main fuses
I	Main contactor
J	IGBT-PCBs (EPS496)
K	IGBTs
L	Sensing transformer
M	Output filter
N	Remote control PCB (EPS495 or EP00047)
O	Lightning arrestors
P	Output measure PCB (EPS442)
Q	Hall sensor
R	Input terminals
S	Main transformer

2.4 Components

For the exact location and connectors see [Layout of the Equipment Cabinet](#) and the electrical scheme. You can find the electrical scheme attached on the outside of the equipment.

2.4.1 Line input

Figure 2: Input terminal, all cabinets

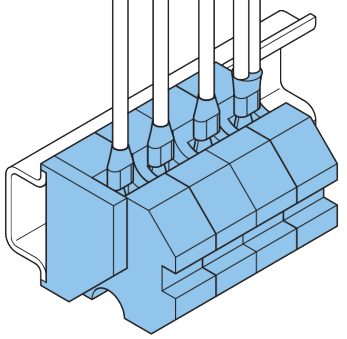

The input terminal connects the power input cables to the equipment.

Figure 3: Line filter, all cabinets

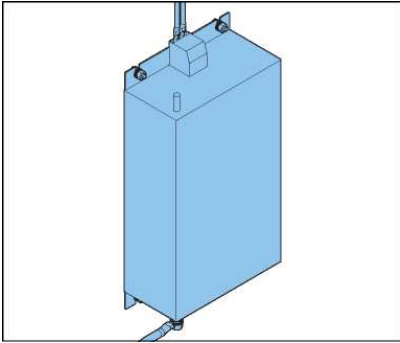

The line filter blocks the noise the equipment generates to the line input and filters out voltage pulses from the input voltage.

Figure 4: Manual switch, all cabinets

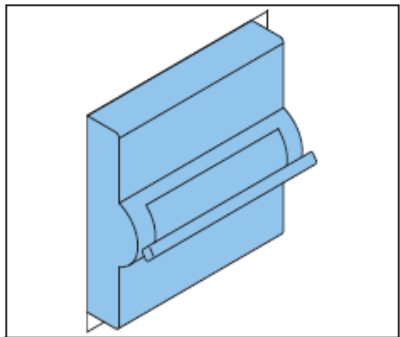

The manual switch is a magneto-thermal switch that connects the mains power supply to the equipment. You can manually set the switch to the **ON** or **OFF** position.

Figure 5: Main fuses, small cabinet

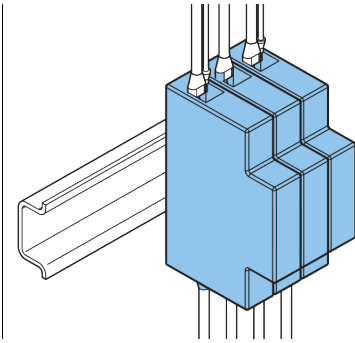

The main fuses disconnect the equipment from the mains power supply if the input current is above a given value.

Figure 6: Main fuses, big cabinet

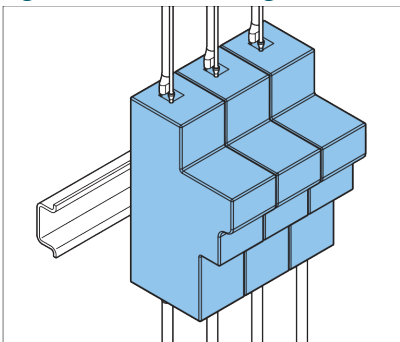

The main fuses disconnect the equipment from the mains power supply if the input current is above a given value.

Figure 7: Main contactor, small cabinet

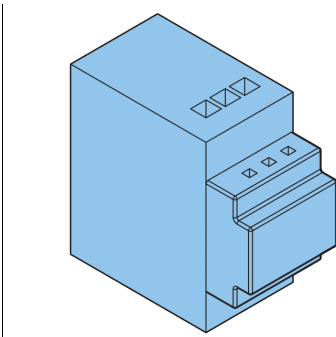

The main contactor allows the power supply PCB to automatically interrupt the power.

Figure 8: Main contactor, big cabinet

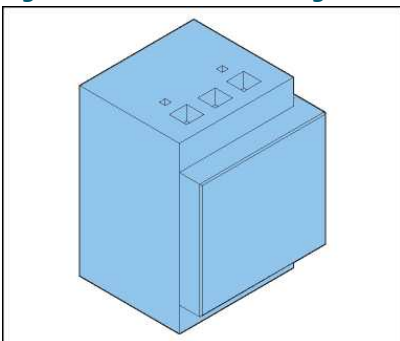

The main contactor allows the power supply PCB to automatically interrupt the power.

Figure 9: Precharge contactor, small cabinet

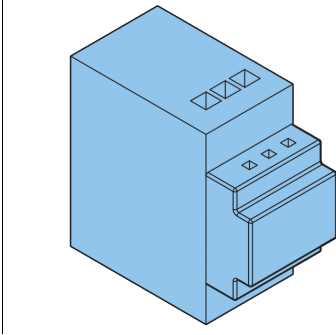

The precharge contactor allows a smooth charge of the capacitors on the capacitor bank.

Figure 10: Precharge contactor, big cabinet

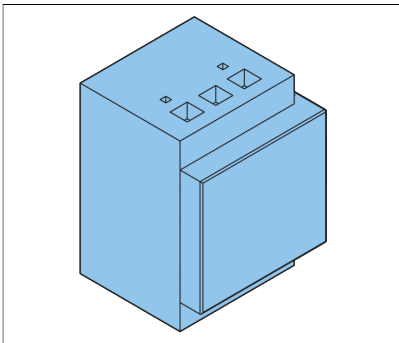

The precharge contactor allows a smooth charge of the capacitors on the capacitor bank.

Figure 11: Precharge PCB (EPS456), all cabinets

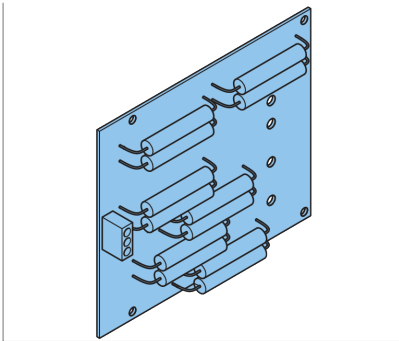

The resistors on the precharge PCB limit the current for the precharge of the capacitor bank.

Figure 12: Sensing transformer, all cabinets

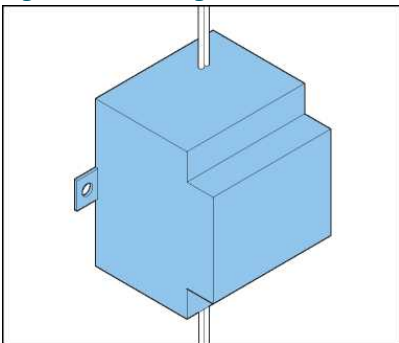

The sensing transformer measures the difference in the input voltage level between phases L1 and L2.

Figure 13: Power supply transformer, all cabinets

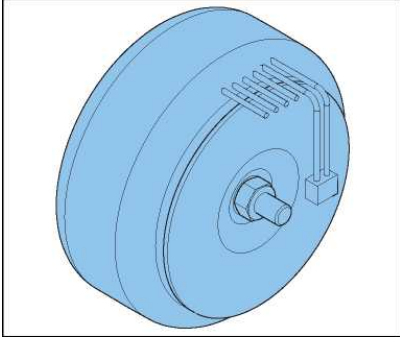

The power supply transformer:

- Measures the input voltage level between phases L2 and L3.
- Provides the correct current and voltage to power all the electronic components such as PCBs and to power the fans (for 15 to 30kVA equipment).

2.4.2 IGBT power bridge

Figure 14: Diode bridge + sensing PCB (EPS540 / EPS541), small cabinet

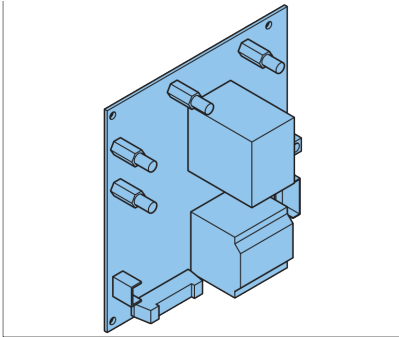

The diode bridge converts the AC line input to a rectified current and voltage.



Note

The sensing PCB measures the AC input line.



Note

In the small cabinet, the sensing PCB and the diode bridge are combined into one part.

Figure 15: Sensing PCB (EPS497), big cabinet

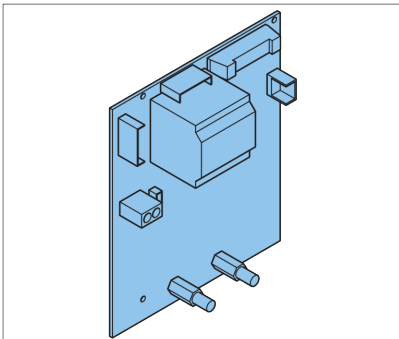

Note

The sensing PCB measures the AC input line and controls the diode bridge.



Note

In the big cabinet, the sensing PCB and the diode bridge are separate parts.

Figure 16: Diode bridge, big cabinet

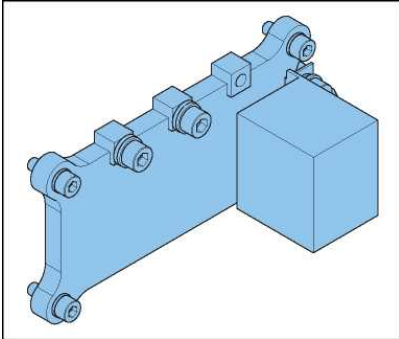

The diode bridge converts the AC line input to a rectified current and voltage.



Note

In the big cabinet, the sensing PCB and the diode bridge are separate parts.

Figure 17: IGBT, all cabinets

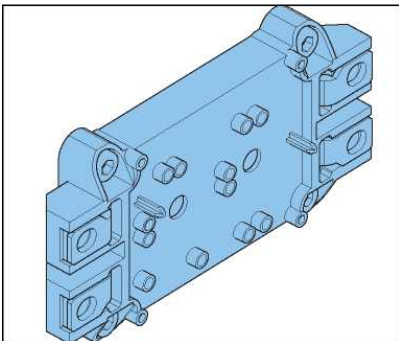

An IGBT controls a high power via a low power electronic signal.

The IGBT can switch at high frequency.

Two IGBTs are installed together in one housing.

The system uses four IGBTs connected as an H-bridge to make an AC-signal.

Figure 18: IGBT PCB (EPS477 /EPS496 /EPS 478), all cabinets

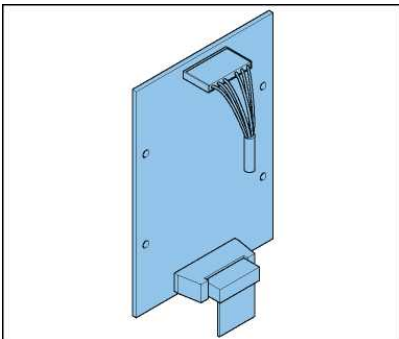

The IGBT PCB measures the output signal from the IGBT H-bridge.

2.4.3 Capacitor bank

The capacitor bank smoothens the DC current and voltage to make a constant DC current and voltage.

Figure 19: Capacitor bank, small cabinet

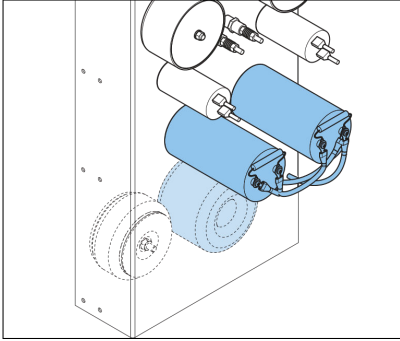
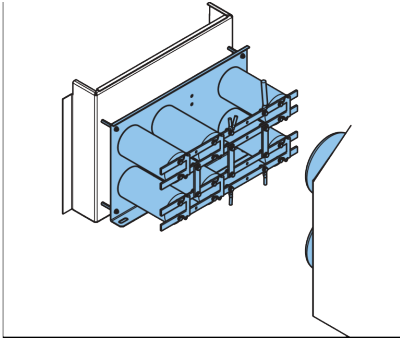
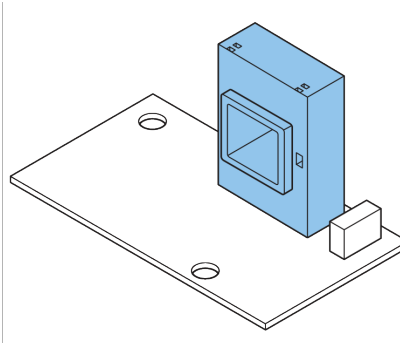

Figure 20: Capacitor bank, big cabinet



2.4.4 Hall sensor, big cabinet

Figure 21: Hall sensor, big cabinet



The Hall sensor measures the current between the IGBT and the output filter.

2.4.5 Output filter

Figure 22: Output filter, small cabinet

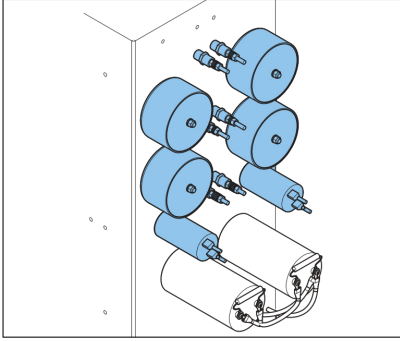

The output filter is a Pulse Width Modulation (PWM) filter that builds the pure sine wave signal that comes from the H-bridge.

Figure 23: Output filter, big cabinet

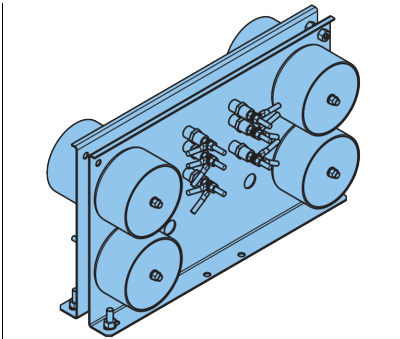

The output filter is a Pulse Width Modulation (PWM) filter that builds the pure sine wave signal that comes from the H-bridge.

2.4.6 Main transformer, all cabinets

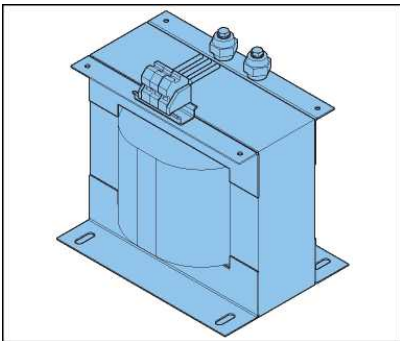

The main transformer converts the pure sine wave to the correct output voltage and current.

2.4.7 Output measure PCB (EPS422), all cabinets

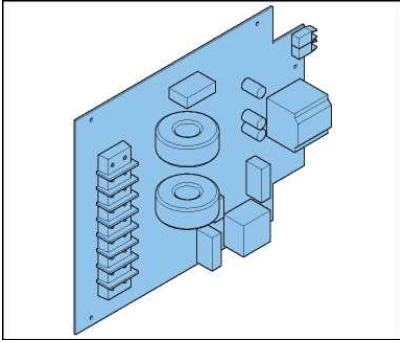

The output measure PCB measures the output voltage and current and sends these measurements to the CPU PCB.

The EFD (See [Earth Fault Detection \(EFD\)](#)) and LFD (See [Lamp Fault Detection \(LFD\)](#)) logic is also located on the output measure PCB.

2.4.8 Power output

Lightning arrestors, all cabinets

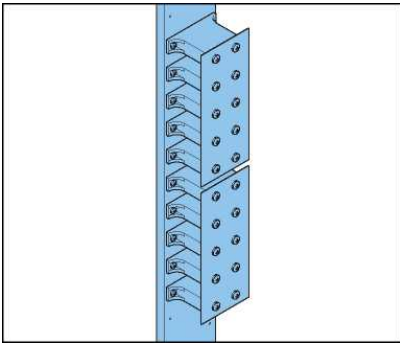

- The lightning arrestors are installed on the power output. The lightning arrestors are varistors.
- A varistor is a surge protection device that is connected directly across the AC output.

Connection to the series circuit

- There are mutual exclusive options possible. See [Options](#).

2.4.8.1 CPU PCB (EPS479), all cabinets

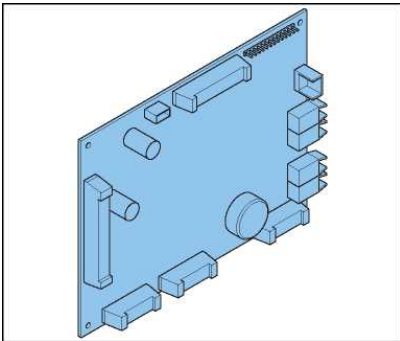

The CPU PCB:

- Receives the measurement data of the output current and voltage from the output measure PCB via an optical fibre and compares these values with the required values. A software algorithm processes this data to adjust the signals from the output filters.
- Receives and processes input signals from the HMI and the remote control PCB.

2.4.8.2 Remote control PCB (EPS495 or EP00047), all cabinets

Note Until 2022, the VIS was delivered with the EPS495 board as the remote control PCB. Since 2022, the VIS has been delivered with the EP00047, and the EP00051 as an add-on board when Multiwire is required. The functionalities of these boards are equivalent in most cases, with the exception of the most demanding recent ALCMS systems with a redundant bus. For VIS units equipped with the EPS495, there are options to transition to the EP00047 (and the EP00051 add-on if needed) when required. Please contact your ADB Safegate representative for more details if needed.

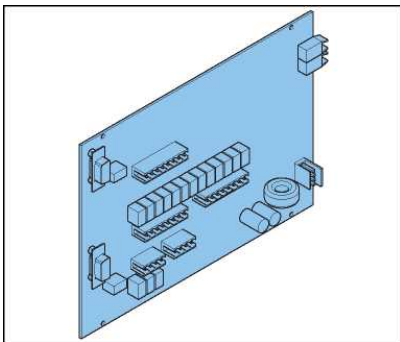

The equipment can be monitored or controlled remotely with J-Bus (2-wire RS485), multiwire or ethernet. This remote control allows the remote control system to:

- Receive information about the equipment.
- Configure the brightness steps.
- Test the equipment.

The remote control PCB connects the equipment to the remote control system. The internal connection between the remote control PCB and the CPU PCB goes through an optical fibre.

Note For EPS495, remote control through an ethernet connection requires an additional PCB. See [Ethernet PCB \(EPS542\)](#), all cabinets.

Note For EP00047, Multiwire support requires an add-on PCB, EP00051.

2.4.8.3 Power supply PCB (EPS480), all cabinets

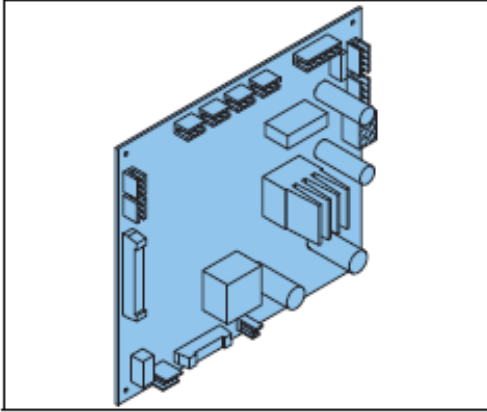

The power supply PCB provides the power supply for:

- All electronic components such as PCBs of the equipment
- The fans (for 15 to 30 kVA equipments)
- The control for the main contactor

The power supply PCB also manages the safety switches on the panels.

2.4.8.4 Lamp Fault Detection (LFD)

The equipment analyses the output current and the voltage pattern to calculate, on a linear load, the number of open circuited lamps, in compliance with IEC 61822:2009.

The accuracy is ± 1 lamp with a range from 1 to 15 broken lamps.

The HMI shows the actual LFD value.

2.4.8.5 Earth Fault Detection (EFD)

The EFD measures the insulation resistance between the series circuit and the earth in compliance with IEC 61822:2009.

The EFD module works when the equipment is connected to the mains supply, even if no output current is present.

You can set two alarm levels, Level 1 and Level 2, for the measured values. Both alarm levels can be set to any value between 5 kOhm and 500 MOhm. However, Level 1 must always be higher than Level 2.

Working principle: A high-voltage resistor applies a stable, current-limited voltage of 450 VDC between the series circuit and the earth or cable screen.

The HMI shows the actual EFD value.



Note

EFD measurement is done through a DC voltage with a positive voltage applied on to the series circuit and the 0 (zero) to the earth.

2.4.8.6 Ventilation

The equipment has air ventilation grids for air inlet and air outlet. The air circulation cools the equipment. For 15 to 30 kVA equipments, additional fans cool the equipment.

2.5 Options

2.5.1 Remote control

Note

Until 2022, the VIS was delivered with the EPS495 board as the remote control PCB. Since 2022, the VIS has been delivered with the EP00047, and the EP00051 as an add-on board when Multiwire is required. The functionalities of these boards are equivalent in most cases, with the exception of the most demanding recent ALCMS systems with a redundant bus. For VIS units equipped with the EPS495, there are options to transition to the EP00047 (and the EP00051 add-on if needed) when required. Please contact your ADB Safegate representative for more details if needed.

The following remote control connections are possible:

- Ethernet (Ethernet PCB required for EPS495)
 - Single
 - Double
- J-Bus
 - Single
 - Double
- Multiwire with 8 input signals and 17 output signals, always possible to monitor via single J-Bus. For CRE units equipped with EP00047, the add-on board EP00051 is also required.

2.5.2 Ethernet PCB (EPS542), all cabinets

Note

This applies to CRE units equipped with EPS495.

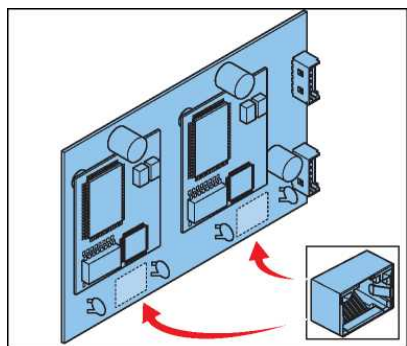

The ethernet PCB converts the ethernet to an RS-485 signal. This PCB is required for EPS495 if you need to remotely operate the equipment through an ethernet connection.

The illustration shows a double ethernet connection.

2.5.3 Circuit selector (CS)

With a CS you can connect several (up to eight) series circuits to a single equipment.

The CS has two modes:

- Simultaneous: the equipment can connect to a number of the available circuits at the same time
- Alternate: the equipment can connect to only one circuit at a time

2.5.4 Lightning arrestors (option CS)



Note

This item is installed on the CS when the CS option is chosen.

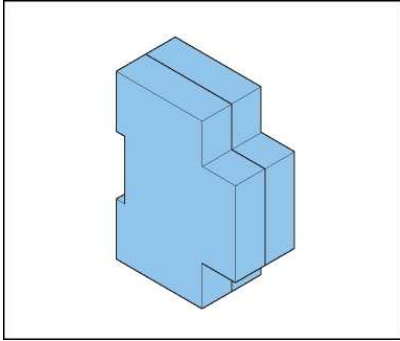

The additional lightning arrestors for the CS are installed on the power output. The lightning arrestors are varistors. A varistor is a surge protection device that is connected directly across the AC output.

2.5.5 Interface PCB (PCB1702) (option CS)



Note

This item is installed on the CS when the CS option is chosen.

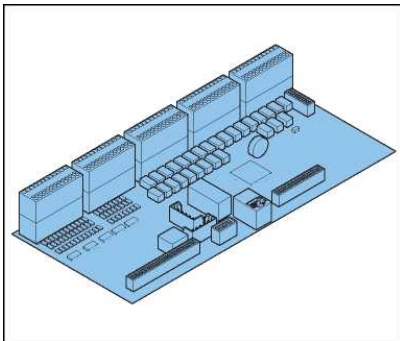

The interface PCB is the remote control interface PCB of the equipment, if the equipment has a CS.

2.5.6 CS PCB (PCB1619) (option CS)



Note

This item is installed on the CS when the CS option is chosen.

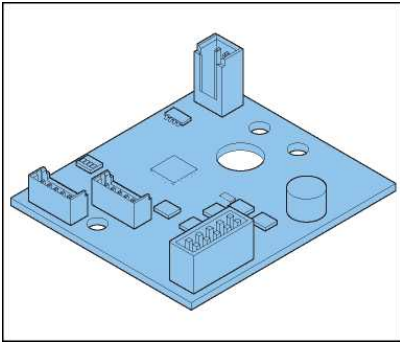

The CS PCBs drive the CS relays through CANbus and measure the current after the relay with a current sensor. (see [Current sensor \(option CS\)](#)).

2.5.7 HMI SIN PCB (PCB1703) (option CS)

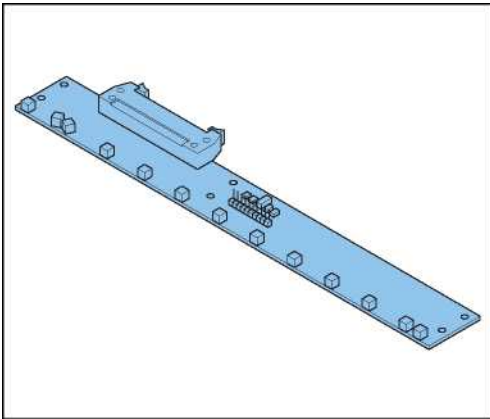

Note

This item is installed on the CS when the CS option is chosen.

The HMI SIN BCB provides the indication of the state of the different series circuits (selected or not selected).

2.5.8 Remote control SIN PCB (PCB1694) (option CS)



Note

This item is installed on the CS when the CS option is chosen.

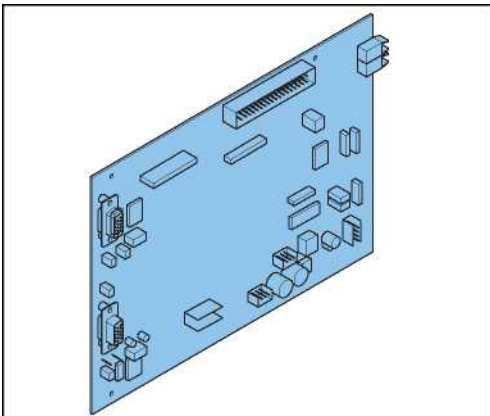

The remote control SIN PCB is the interface between the CPU PCB and the interface PCB

2.5.9 CS relay (option CS)

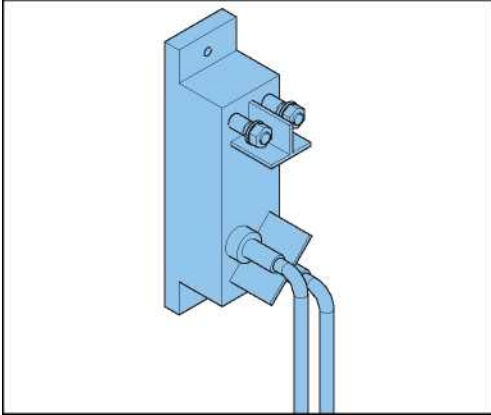

i Note This item is installed on the CS when the CS option is chosen.

The CS relays switch on or off its designated series circuit.

2.5.10 Current sensor (option CS)

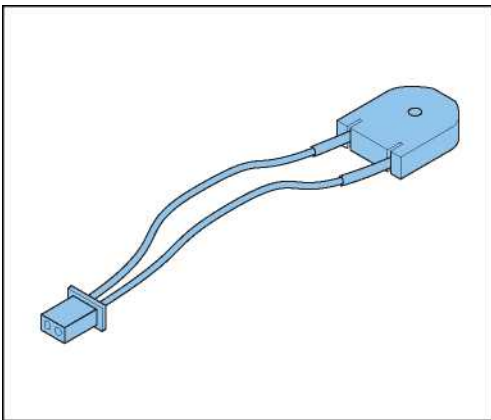

i Note This item is installed on the CS when the CS option is chosen.

The current sensors sense current running through the series circuits.

2.5.11 Series Connector Box (SCB), all cabinets

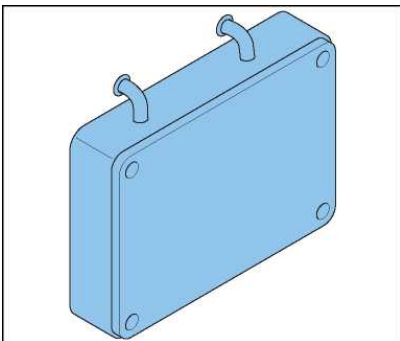

The SCB connects the equipment to the series circuit with two medium voltage cables of the primary circuit. The SCB does not allow the short circuit connection.

2.5.12 Series CutOut (SCO), all cabinets

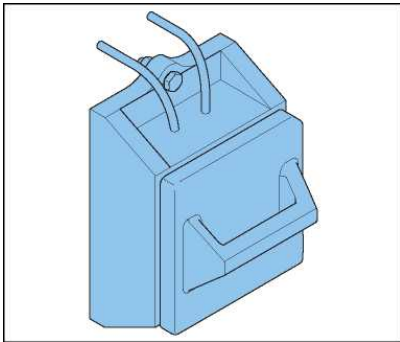

The SCO acts as an output disconnection device between the equipment and the series circuit. The SCO also isolates the series circuit from the equipment during maintenance or testing operations. The cover is locked with a key to prevent unauthorized access.

2.5.13 Rolling castors

The equipment can be supplied with two fixed and two pivoting rolling castors to facilitate the movement of the equipment. The option is not available for stackable equipments or for an equipment with a CS.

2.6 HMI

You can operate the equipment with the HMI.

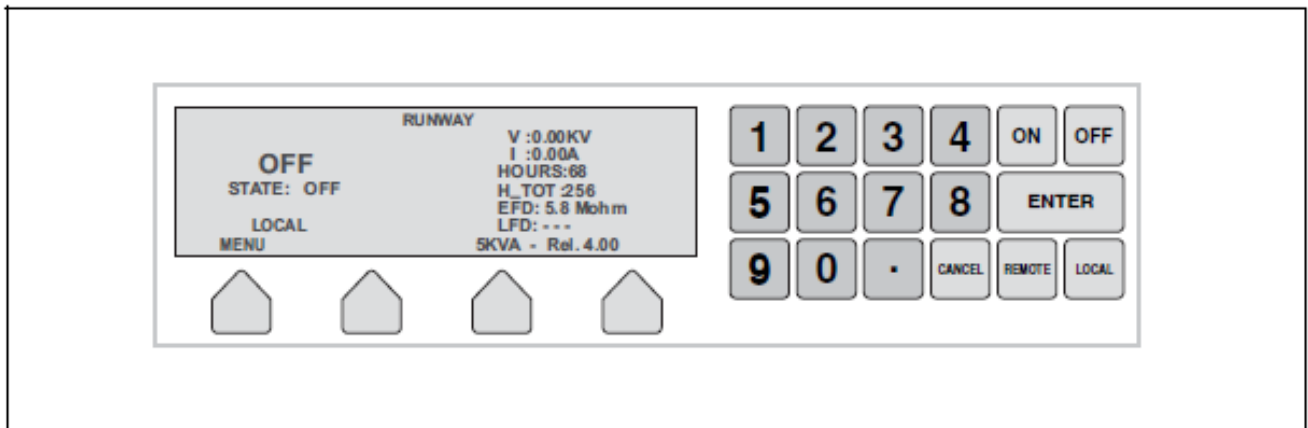

2.7 HMI of an equipment with CS (option CS)

You can operate the equipment with the HMI.

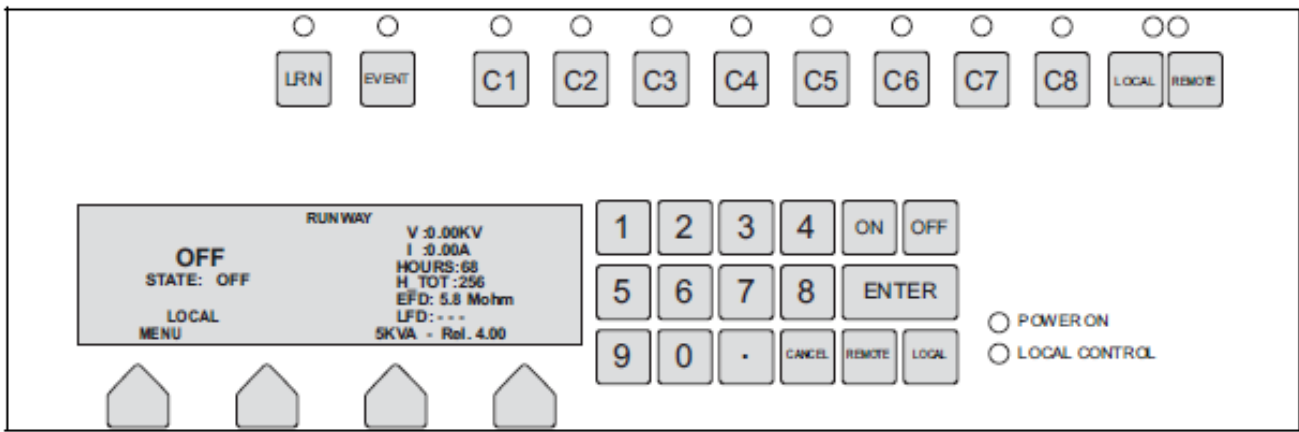

2.8 Nameplate

Each equipment has a standard nameplate:

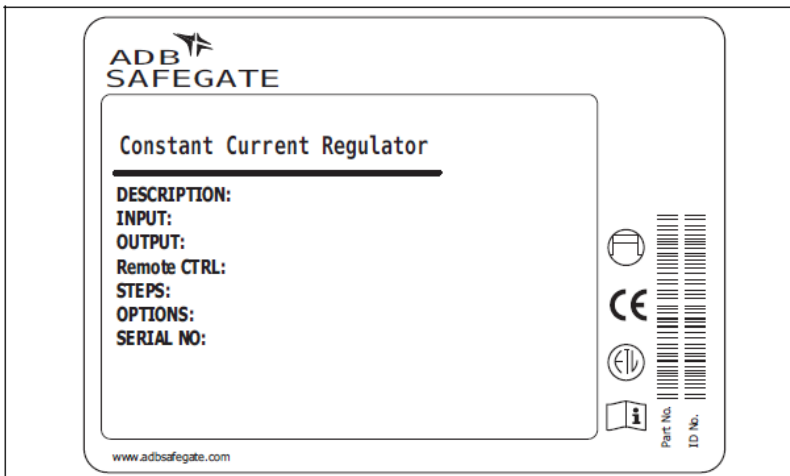

3.0 Inspection, Transportation and Storage

3.1 Inspect equipment on delivery

Each equipment comes in a crate.

1. Check that the crate is not damaged.
2. In case of damage, inform the carrier immediately.
3. Unpack the crates. See [Unpack at installation area](#).
4. Check if the equipment corresponds to your order.
5. Check the equipment for damage.
6. In case of damage or if the equipment does not correspond to your order, inform the carrier immediately.

3.2 Transport and unpack the crate

Observe the following caution while transporting the crate:



CAUTION

- The maximum weight of the equipment is approximately 500 kg.
- Keep the crate in a vertical position at all times.
- Do not let the crate tilt or fall.
- The center of gravity of the crate is not the same as the physical center of the crate.

Unpack at installation area

1. Make sure that the crate is at the installation area.
2. Remove the cover and side panels of the crate.

3.3 Transport Unpacked Equipment

Transport equipment with lifting lugs

You can lift all equipment configurations when you take into account these rules:

- Always use the lifting lugs (option) and adequate hoisting cables to lift the load. If required, remove the side panels from the equipment before you lift it.
- Do not let the load swing without control.
- Install the top panel (roof) of the equipment.
- Use the correct type of eye bolt. Suppliers of eye bolts provide data on configurations and maximum allowed load for different types of eye bolts. Use a rotation eye bolt to cover all applications with the same type of eye bolt.



Note

Contact ADB Safegate for the correct eye bolt type.

Prepare

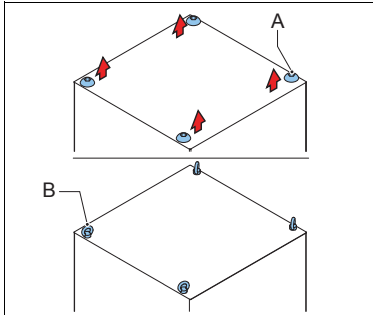

1. Remove the bolts (A).
2. Install the lifting lugs (B).

Transport

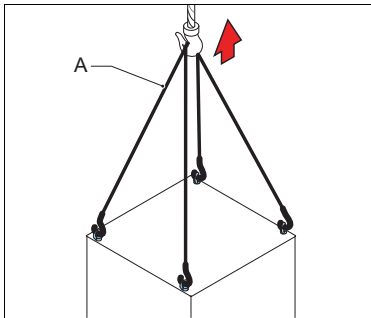

1. Secure a chain or a rope (A) to the lifting lugs.
2. Slightly lift the equipment. The cables tighten.
3. Carefully move the equipment to the applicable location.

Transport - small and big cabinet with wheels

Push the equipment to the applicable location.



WARNING

Make sure that the ground surface is flat and horizontal.

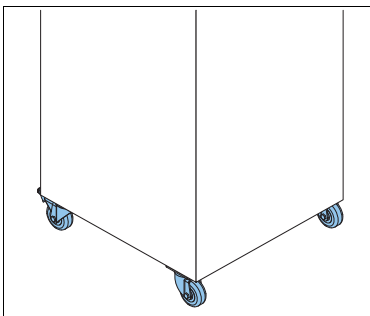

3.4 Storage

Make sure to do the following regarding storage:

- Do not store the equipment for a prolonged period in its packaging.
- Store the equipment in an environment that complies with the environmental conditions defined for its use in the environmental conditions under the Technical Data section.
- Inspect the equipment regularly.

Do the following after a long storage period:

- Clean the equipment, if necessary.
- Remove the oxidation layer from the electrical contact before connection, if necessary.



NOTICE

For long term storage, it is recommended to keep the equipment in a dry (<60% humidity) and moderate temperature area (15–30°C ambient temperature).

4.0 Pre-Installation

4.1 How to pre-install - general procedure

1. Prepare the substation for the equipment. See [Prepare Substation](#).
2. Prepare the lightning protection. See [Prepare lightning protection](#).
3. Plan a power supply for each equipment. See [Install power supply](#).
4. Plan the cables and the lay-out of the cables. See [Plan cables and lay-out of cables](#).

4.2 Prepare Substation



WARNING

Make sure that the supply voltage of the equipment is in accordance with the local supply voltage.

1. Make sure that the substation complies with the general substation specifications. See [Substation specifications](#).
2. Make sure that sufficient heat dissipation is present. See [Provide heat dissipation](#).
3. Make sure that sufficient ventilation is present. See [Ventilation](#).
4. Make sure that the substation layout meets the minimum clearance specifications. See [Substation Layout](#).
5. Install an external fuse. See [External fuse](#).
6. Make sure that the circuit breakers are of the correct type. See [Circuit breakers](#).
7. Install the separate disconnection devices. See [Disconnection devices](#).

Substation specifications

For details on the substation specifications below, see ICAO Aerodrome Design Manual, Part 5 Electrical Systems, DOC 9157-AN/901.

Item	Description
Vault lighting	Well illuminated for used day and night. Follow the local regulations
Shelter	<ul style="list-style-type: none">• Clean and dry• Lockable• Fireproof• Separate construction with reinforced concrete floors and walls• Adequate drainage above ground level• Sufficient room and lighting for personnel to do maintenance work
Location	<ul style="list-style-type: none">• Reasonable distance from the control tower• Leaves limitation surfaces free• Vehicular access in all weather conditions• Minimum interference with aircraft traffic
Ventilation	Install forced ventilation
Electrical connections	<ul style="list-style-type: none">• Sufficient number of conduits and cable entrance accesses• Sufficient power to supply all equipments• Access to the required power supply, remote control and series circuit cabling• Ground network• External fuse and an electrical distribution cabinet• Disconnection devices for the input and output current

4.2.1 Provide heat dissipation

The equipment meets the FAA AC150/5345-10F standard for equipment efficiency.

Table 1: Indicative values for heat dissipation

Equipment [kVA]	Heat dissipation [W]
2.5	250
4	400
5	500
7	750
10	900
15	1200
20	1400
25	1750
30	1800

Make sure that the heat dissipation efficiency is better than 90% for an equipment less than 30kVA and at least 92% for a 30kVA equipment.



Note

The necessary heat dissipation also depends on the input voltage range and on the ambient conditions.

4.2.2 Ventilation



CAUTION

If there is not enough air-flow, the components of the equipment become too hot.

Make sure that you do not block the ventilation grids (A) of the equipment.

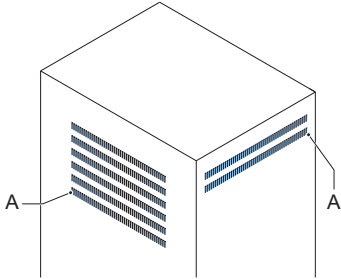

External fuse

Install the external fuse in the distribution panel with at least one rating higher than the manual switch (see [Protection Devices](#)) for fuses type gG or aM.

Circuit breakers

1. If you use circuit breakers, make sure they are of the type D, or an equivalent type. This means that the magnetic trip current must be from 10 up to 14 times higher than the nominal current.
2. If you install more than one circuit breaker close to each other, make sure that you take into account the thermal derating to maintain the selectivity.

Disconnection devices

Install a separate disconnection device for the input and output power, according to these standards:

- FAA: AC 150/5345-10F and L829
- IEC: IEC 61822

Install power supply

1. Install a power supply for each equipment.
2. Make sure the protection devices are correct. See also [External fuse](#), [Circuit breakers](#) and [Disconnection devices](#)

4.3 Prepare lightning protection

1. Examine the need for additional lightning protection.
2. If you need additional lightning protection, contact ADB Safegate to supply lightning diverters in accordance with IEC 61822.

4.4 Install power supply

1. Install a power supply for each equipment.
2. Make sure the protection devices are correct. See also [External fuse](#) , [Circuit breakers](#), and [Disconnection devices](#).

4.5 Plan cables and lay-out of cables

1. Plan the routing of the cables so that the power cables and remote control cables are separated from each other.
2. Plan the cable slack. See [Plan the cable slack, big and small cabinet](#) .
3. Plan the power supply cables and earthing cables. See [Power supply cables and earthing cables](#).
4. Plan the cables to the remote control interface (option). See [Plan cables to remote control interface](#).
5. Plan the cables for the series circuit. See [#unique_66/unique_66_Connect_42_section-2893](#).

Plan the cable slack, big and small cabinet

Required cable slack from the bottom to the top of the cabinet:

- X: maximum 1000 mm for the input power supply.
- Y: maximum 1000 mm for the output power supply.
- Z: maximum 1500 mm for the remote control cables.

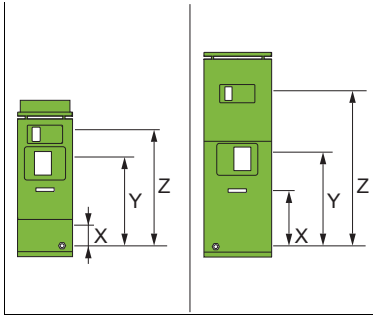

Power supply cables and earthing cables

Make sure that you plan power supply and earthing cables that comply with table 3-B in IEC 6095-1 latest edition.

4.5.1 Plan cables to remote control interface



WARNING

Only earth the remote control cable at one end, preferably at the equipment side.

Multiwire cables (option)

1. Plan screened cables with the screen connected to the ground at only one end.
2. Plan the signal wires. See also the remote control scheme in [Multiwire / J-Bus connection scheme](#)
 - Plan one paired wire for the signal and the other wire of that pair as a return. Bundle all returns to the same terminal to minimize the voltage drop.
 - Do not combine the remote control and back-indication signals in one cable, except when these signals do not require more than low-level isolation. The latter is the case if the remote control and back-indication signals use one common energy source.
3. Calculate the wire sections. Take into account these items:
 - The tolerances of the power supply.
 - The maximum permitted voltage drop on the line. This is the minimum available power supply voltage minus the minimum required voltage for the load. The coils of the relays have a resistance of 1700 Ohm.
 - The typical resistance.
 - The required load current in each line.
 - The number of signals that may exist at the same time.

Table 2: Recommended multiwire cables

Type	Number of conductors	Diameter [mm]
JE-LiYCY with armouring type R, B, Q or Z	number of signals + return(s)	0.5
TWAVB	number of signals + return(s)	0.8

Table 3: Wire sections and cable lengths for multiwire cables

Diameter [mm]	Typical resistance at 55 °C [Ohm/m]	Power supply tolerance [%]	Maximum cable length 48 V DC [km]	Maximum cable length 24 V DC [km]
0.5	0.1	-5	3	0.65
		-10	1.7	-
0.8	0.04	-5	7.5	1.5
		-10	4	-

J-Bus cables (option)

Ideally, the maximum length of a J-Bus cable is 1200 m.



CAUTION

Do not mix J-bus A and J-bus B signals in one pair.

1. For a Tx+/Tx- and Rx+/Rx- connection, plan a twisted-pairs cable.
2. Provide screened (armoured) data cable according to the selected protocol:
 - RS485 (2 wire communication).
 - One cable for a single J-bus, two cables for a dual J-Bus.

Table 4: Wire sections for J-Bus cables

Cable type	Number of wires	Diameter [mm]
JE-LiYCY (with armouring type R, B, Q or Z)	2 or 3 pairs twisted	0.5
TWAVB	4 or 6 x 0.8mm (0 V wire)	0.8

Ethernet cables (option)

Use an FTP CAT 5e patchcable to limit the electromagnetic interference. You can use also a higher cable standard.

5.0 Installation



WARNING

Always wear protective gloves and shoes when you do work on the equipment or the series circuit.



WARNING

Make sure that the power is **OFF** when you install the equipment.

Main installation procedure

1. Examine the pre-installation. See [Check pre-installation](#).
2. Examine the required tools. See [Required tools and equipment](#).
3. Transport the cabinet to the correct location. See [How to transport the crate](#).
4. Unpack the equipment. See [Unpack at installation area](#).
5. Examine the equipment. See [Inspect equipment on delivery](#).
6. Remove the lower rear panel. See [Remove lower rear panel, big and small cabinet](#).
7. Install the electrical connections:
 - Switch off the power supply. See [Switch OFF the power supply](#)
 - Install additional earthing. See [Install additional earthing, big and small cabinet](#).
 - Connect the power input supply. See [Connect power input supply, big and small cabinet](#).
 - Connect the output to the series circuit. See [Connect Output to Series Circuit](#).
8. Install the remote control connections. See [Connect Remote Control Cables](#).
9. Install the panels. See [Install Lower Rear Panel](#).

Check pre-installation

Table 5: Pre-installation checklist

Checked	Item
	The substation meets the general requirements
	The cables have been installed according to an applicable layout
	All the cables have enough slack to connect to the equipment
	All the cables meet the specifications
	For each equipment there is a power supply cable available
	For each equipment there is a remote control cable available
	For each equipment there is a series circuit cable available

5.1 Required tools and equipment

Required safety items

- Protective gloves
- Protective shoes

Required meters

- True RMS Multimeter
 - Isolating measurement transformer
-



CAUTION

The output voltage of the 30 kVA / 6.6 A equipment can reach approximately 4600 V at full load

- Insulation tester "Megger" 5000 V and 10000 V
 - AC True RMS measurement device (follow ICAO part 5 § 3.9.4.7)
-



CAUTION

The current regulation is +/- 1%. To make an acceptable readjustment of the output current, the precision of the meter should be better than 0.5% for the adjusted value.

Required tools

A standard electrical and mechanical tool kit

Required cables

- Remote control cable N x 0.8 mm diameter (between the equipment and the control panel) Remote control cable N x 0.8 mm diameter (between the equipment and the control panel)
- Earthing wire
- Input supply cable
- Series circuit cable

5.2 Inspection

1. Carry out a general inspection. See [Inspect equipment on delivery](#).
2. Examine if the inner side of the equipment is not damaged.
3. Examine the transformers for displacement or bending.
4. If you see damage, displacement or bending, tell the carrier immediately.

5.3 Remove lower rear panel, big and small cabinet

The panels of the equipment can be removed for installation or maintenance procedures.



WARNING

- Do not operate the equipment with any of the panels removed.
- Do not mix panels from different equipment.
- Always connect the earthing wire before you install the panels.

Figure 24: Remove panel

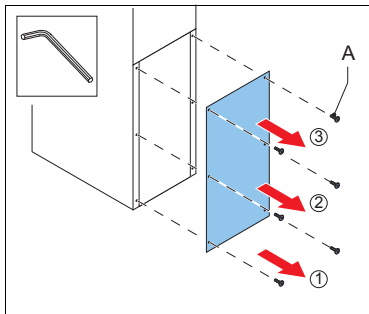

1. Set the manual switch to the **OFF** position.
2. Remove the screws (A) from the bottom to the top.



WARNING

The panels are heavy. Also, the momentum of the panel can cause damage to the panel and the screws if you remove the top screws first.

3. Carefully remove the panel (B).



CAUTION

Do not damage cables and/or connectors.

4. Disconnect the green/yellow earthing wires. The wires have a fast-on connector.

Figure 25: Disconnect wires

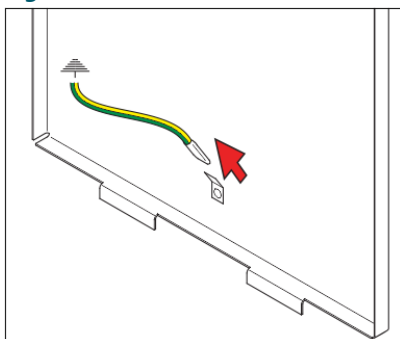

5.4 Switch OFF the power supply

1. Set the manual switch (A) to the OFF position.
2. Open the main switch on the main distribution board.
3. Disconnect the equipment from the series circuit.

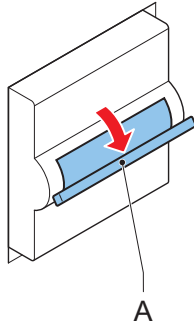

5.5 Install additional earthing, big and small cabinet



Note

The procedure is not applicable when the equipment has a CS.

1. Connect an earthing wire to the M8 earthing screw (A). Use an earthing wire with a cross-section of at least 10 mm². The wire must be as short as possible.
-



WARNING

Earth the cabinet correctly. The equipment can create ground return currents up to 3.5 mA. Also when the equipment is not connected to the load, the equipment can create lethal ground currents.

2. Connect the earthing wire to the earthing network of the substation.

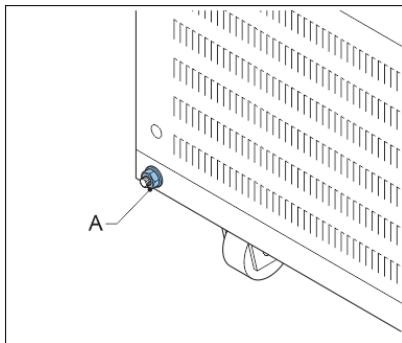

5.6 Connect power input supply

The connection is based on screw terminals.

Strip the cables

- Strip the input power supply cables.
 - 208-230V input
 - up to 15 kVA: 16 mm
 - from 15 to 30 kVA: 18 mm
 - 380-400V input
 - up to 15 kVA: 16 mm
 - from 15 to 30 kVA: 18 mm

Connect - 1

1. Pull the cables through the opening in the rear panel (A).
2. Connect the input supply cables to the terminals (B).
3. Connect the earthing wire to the terminal (C).

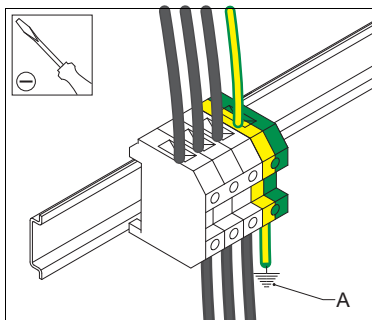
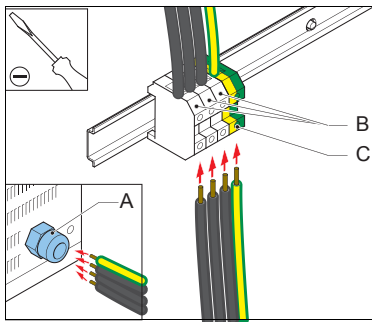

Connect - 2

Connect the earthing wire to the earthing network (A) of the substation.

5.7 Connect Output to Series Circuit



CAUTION

If the series circuit cable is screened, connect the screen to an earthing network either inside or outside the equipment.

The procedures show how to connect the integrated output connections:

- With SCB (option). See [Connect Output to Series Circuit with SCB](#).
- With SCO (option). See [Connect Output to Series Circuit with SCO](#).

If the output connection is not integrated in the equipment, see the dedicated installation manuals:

- AGLAS Master
- External SCO

5.7.1 Connect Output to Series Circuit with SCB

Strip cables

Strip the series circuit cables at the end.

- A: unscreened cables
 - X: 16 mm
 - \varnothing Y: less than or equal to 18 mm
- B: screened cables
 - X: 16 mm
 - \varnothing Y: less than or equal to 18 mm
 - U: 11 mm
 - Z: 77 mm

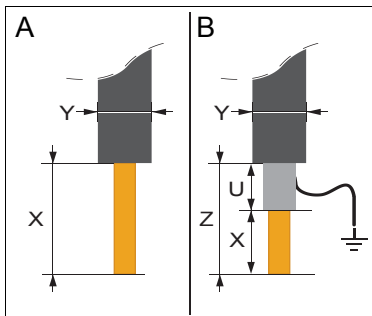

Remove the box panel

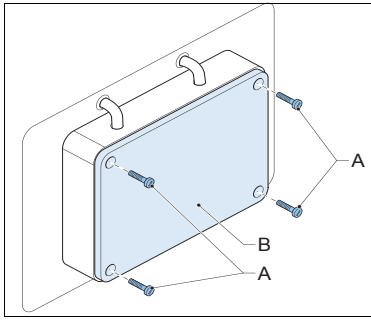

1. Loosen the screws (A).
2. Remove the box panel (B).

Connect

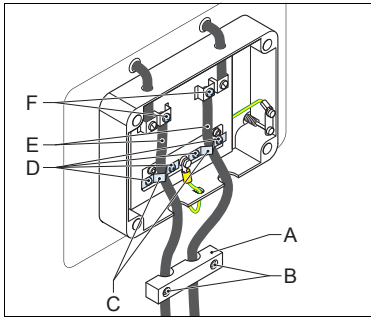

1. Loosen the screws (B) of the cable guide (A).
2. Loosen the screws (D) of the stress-relief clamps (C)
3. Lead the series circuit cables (E) through the cable guide and through the stress-relief clamps.
4. Loosen the screws (F).
5. Install the series circuit cables.
6. Tighten the screws (B), (D) and (E).

Finish

Install the box panel.

5.7.2 Connect Output to Series Circuit with SCO

Remove cover

Remove the cover (A) of the SCO.

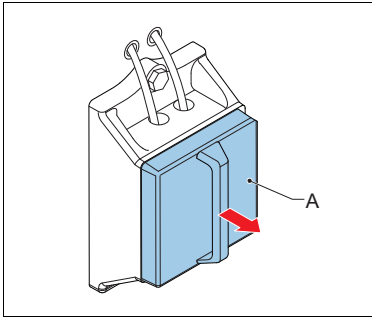

Strip cables

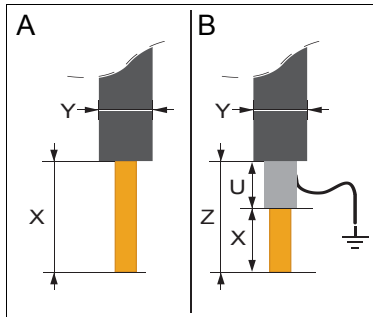

1. Strip the series circuit cables at the end.

- A: unshielded cables
 - Strip the series circuit cables at the end.
 - X: 14 mm
 - \varnothing Y: less than or equal to 12 mm
- B: shielded cables
 - X: 16 mm
 - U: 10 mm
 - Z: 43 mm

Installation - Connect

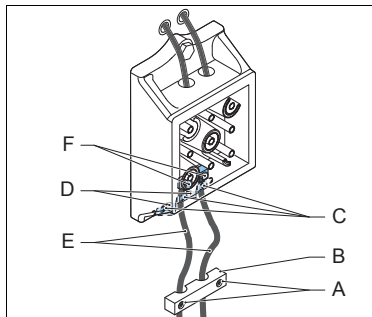

1. Loosen the screws (A) of the cable guide (B).
2. Loosen the screws (C) of the stress-relief clamps (D)
3. Lead the series circuit cables (E) through the cable guide and through the stress-relief clamps.
4. Loosen the screws (F).
5. Install the series circuit cables.
6. Tighten the screws (A), (C) and (E).

5.8 Connect Remote Control Cables

Connect multiwire or J-Bus (option)



Note

If the terminal blocks are not located on the correct sides, the remote control does not work.

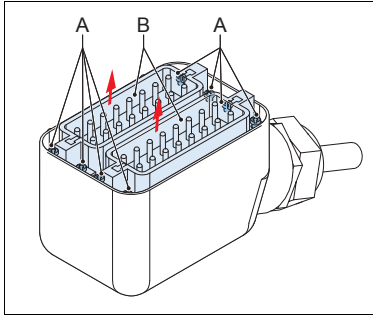

To disassemble the connector:

1. Remove the screws (A).
2. Note the correct side for each terminal block (B).
3. Remove the terminal blocks (B).

Connect - 1

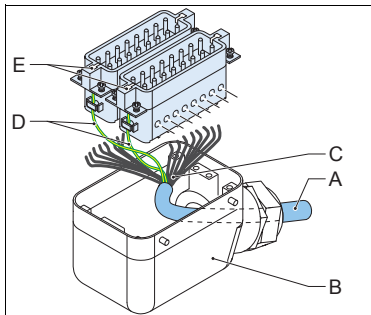

1. Put the remote control wire (A) through the connector (B).
2. Strip the signal wires (C) approximately 100 mm.
3. Connect the signal wires to the terminal blocks. For the connection scheme, see [Multiwire / J-Bus connection scheme](#).
4. Connect the earthing wire (D) to the earthing connector (E).

Connect - 2

1. Install the terminal blocks to the connector.
2. Make sure that the orientation of the terminal blocks corresponds with the illustration above.
3. Examine if the numbers on the connector correspond with the numbers on the female side on the receiver of the remote connector.
4. Install the connector to the equipment.
5. Close the clamps of the connector.

Connect ethernet cable(s) (option)

Install the connector(s) to the ethernet connection(s).

5.9 Install Lower Rear Panel

Connect the earthing wire and install the lower rear panel. See [Remove lower rear panel, big and small cabinet](#).

6.0 Technical Data

Table 6: Technical Specifications

Item	Description
Rated input voltage [V]	400 V AC ($\pm 10\%$) single phase
Rated frequencies [Hz]	50 or 60
Current regulation limits	Current regulation is guaranteed under the following conditions (± 0.1 A): <ul style="list-style-type: none"> • Under IEC 61822:2009 environmental conditions • For nominal input voltage under IEC or FAA standard conditions • From full load to short circuit
Current regulation modes	Two preset regulation modes: <ul style="list-style-type: none"> • normal mode (for linear loads) • inductive mode (for non-linear loads (e.g. LED loads))
Average efficiency at full load	92 to 94% depending on the size of the equipment, under nominal resistive load, nominal output current, and nominal input voltage
Power factor at output	The power factor exceeds the IEC and FAA requirements. The power factor at rated load is close to 1 and is kept at a high level for possible operational conditions
Brightness steps	5 standard, 8 maximum, fully adjustable in 65k levels (1mA resolution)
Output current [A]	6.6
Remote control and monitoring	<ul style="list-style-type: none"> • Multiwire: <ul style="list-style-type: none"> • Compatible voltage: for units without circuit selector; 24 VDC for units with circuit selector • Internal power supply: 48 VDC for units without circuit selector; 24 VDC for units with circuit selector • Single or dual J-Bus protocol over RS485/RS422 • Single or dual J-Bus protocol over Ethernet IEEE 802.3
Regulation response time	<ul style="list-style-type: none"> • Less than 0.5 seconds • Exceeds the requirements of IEC 61822:2009
Open circuit output voltage	Less than 1.2 times the nominal output voltage (RMS)
Ingress protection	IP 21

Table 7: Output specifications

Type	Rated output power [kW]	RMS output voltage at 6.6 A RMS output current [kV]	Insulated test on output ¹ [kV]	Output overvoltage protection 25kApk
VIS 2.5	2.5	0.38	3	0.75 kV _{RMS} , 1.4 kJ
VIS 4.0	4.0	0.60	5	1.5 kV _{RMS} , 2.8 kJ
VIS 5.0	5.0	0.75	5	1.5 kV _{RMS} , 2.8 kJ
VIS 7.5	7.5	1.13	6	2.2 kV _{RMS} , 4.2 kJ
VIS 10	10	1.50	10	2.2 kV _{RMS} , 4.2 kJ
VIS 15	15	2.30	12	3.0 kV _{RMS} , 5.6 kJ

Table 7: Output specifications (Continued)

Type	Rated output power [kW]	RMS output voltage at 6.6 A RMS output current [kV]	Insulated test on output ¹ [kV]	Output overvoltage protection 25kApk
VIS 20	20	3.00	15	4.5 kV _{RMS} , 8.4 kJ
VIS 25	25	3.80	19	5.2 kV _{RMS} , 9-8 kJ
VIS 30	30	4.54	23	6.0 kV _{RMS} , 11.2 kJ

Notes

¹ Test condition: 50 Hz sinusoidal wave for 1 minute. The test is done without output overvoltage protections.

6.1 Applicable standards

The equipment is in accordance with these standards:

Standard	Description
ICAO	Aerodrome Design Manual, Part 5 paragraphs 3.2. (current edition)
FAA ¹	AC 150/5345-10 (current edition), L-828 and L-829 except for input voltage
IEC	IEC 61822:2009
CENELEC	EN 61822
CE certified	

Notes

¹ The equipment is not FAA equipment but it complies with most of the FAA requirements.

6.2 ElectroMagnetic Compatibility (EMC)

The equipment is designed to operate in an industrial electro-magnetic environment. The regulator complies with IEC 61822:2009, in accordance with IEC 61000-6-4 and IEC 6-6-2 (generic standard for industrial environment). The equipment is, with adapted test levels, in accordance with IEC/TS61000-6-5, G (substation environment, location G).

6.3 Ambient conditions

The equipment is air-cooled with fans. Thus, the equipment must have a good airflow, especially if they operate near the maximum temperature.

Table 8: Ambient conditions

Item	Description
Temperature	From -20 up to +55 °C ¹
Altitude	From 0 (sea level) up to 1000 meter
Relative humidity	From 10% up to 95% RH without condensation

Notes

¹ For IEC conformity to -40 °C an optional modification is required.

6.4 Dimensions and mass

Figure 26: The small cabinet (A) and the big cabinet (B)

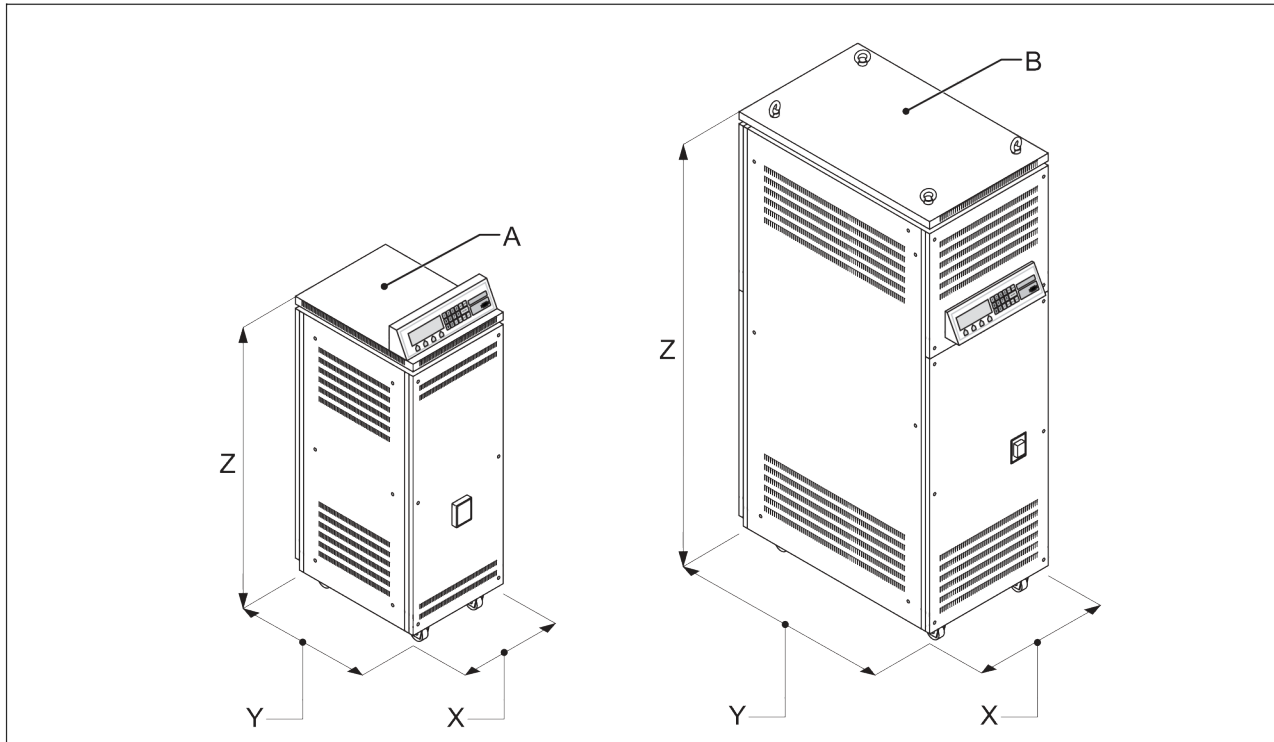

Table 9: Dimensions

Item	A - 2.5 kVA	A - 4 to 15 kVA	B - 20 to 30 kVA
X [mm]	420	420	520
Y [mm] ¹	550	840	840
Z [mm]	1300	1300	1600

Notes

¹ Depending on the output power connection (options)

Table 10: Mass

Type	Net mass	Crate mass	Crate dimensions width x depth x height [mm]
2.5	140	23	1200 x 800 x 1500
4	180	23	1200 x 800 x 1500
5	190	23	1200 x 800 x 1500
7.5	215	23	1200 x 800 x 1500
10	255	23	1200 x 800 x 1500
15	285	23	1200 x 800 x 1500
20	360	40	1200 x 800 x 1850
25	410	40	1200 x 800 x 1850
30	450	40	1200 x 800 x 1850

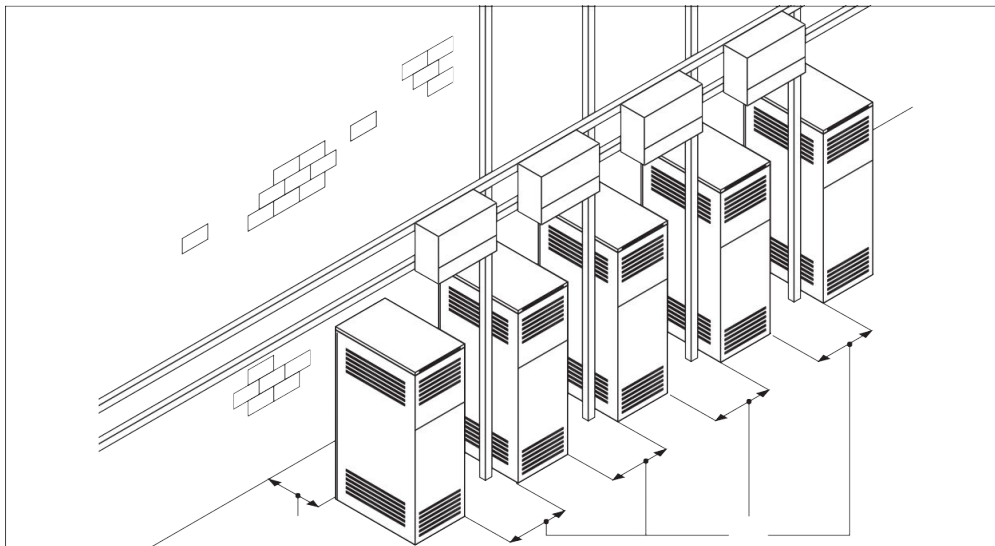

6.5 layout, big and small cabinets

Substation

Table: 7.8 Clearance specifications

Clearance specification	Distance [mm]
Front clearance	Approximately 500
Between the rear of the machine and the wall, X	Approximately 500
Between two machines (side by side) or between another machine, Y	Minimum 150

If necessary, the distances can be increased for maintenance purposes.

6.6 Protection devices

Table 11: Protection devices specifications

Equipment type [kVA]	Equipment voltage [V]	Main fuse rating [A]	Manual switch type C rating [A]	Maximum line input current [A]
2.5	380 to 400	16	10	5.9
4		16	16	9.4
5		16	16	11.7
7.5		20	20	17.6
10		50	40	23.4
15		50	40	35.2
20		80	80	46.9
25		80	80	58.6
30		100	100	70.3

6.7 Remote Control PCB



Note

Until 2022, the VIS was delivered with the EPS495 board as the remote control PCB. Since 2022, the VIS has been delivered with the EP00047, and the EP00051 as an add-on board when Multiwire is required. The functionalities of these boards are equivalent in most cases, with the exception of the most demanding recent ALCMS systems with a redundant bus. For VIS units equipped with the EPS495, there are options to transition to the EP00047 (and the EP00051 add-on if needed) when required. Please contact your ADB Safegate representative for more details if needed.

6.7.1 EPS495 (1597.00.300)

Figure 27: Printed Circuit Board (PCB)

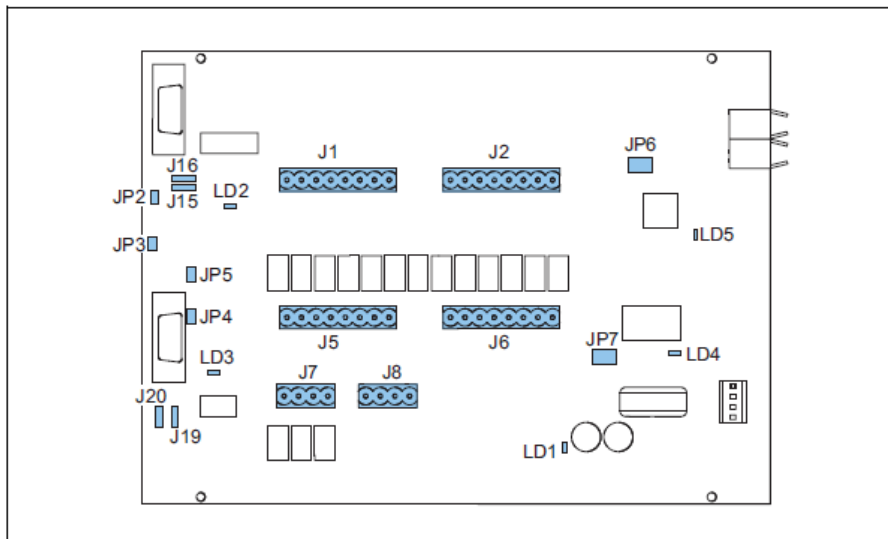

6.7.1.1 LEDs

Table 12: Remote control PCB LED functions

LED	Color	Function
LD1	Green	The LED is green when the voltage of the power supply on the PCB is 12 V DC
LD2	Green	The LED is green when the voltage from the DCDC1, generated on the PCB, is + 5 V DC insulated
LD3	Green	The LED is green when the voltage from the DCDC2, generated on the PCB, is + 5 V DC insulated
LD4	Red	The LED flashes red when the U5 CPU is active
ID5	Red	The LED flashes red when the U6 CPU is active

6.7.1.2 Jumper settings

Table 13: Remote control PCB jumper settings

Jumper	Position	Function
JP2	insert	enable TX serial channel 1 termination resistance
JP3	insert	enable RX serial channel 1 termination resistance
JP4	insert	enable TX serial channel 2 termination resistance
JP5	insert	enable RX serial channel 2 termination resistance

Table 13: Remote control PCB jumper settings (Continued)

Jumper	Position	Function
JP6	position 1-3 and position 2-4 1 3 5 2 4 6	ethernet channel 1: enable
	position 3-5 and position 4-6 1 3 5 2 4 6	serial channel 1: enable
JP7	position 1-3 and position 2-4 1 3 5 2 4 6	ethernet channel 2: enable
	position 3-5 and position 4-6 1 3 5 2 4 6	serial channel 2: enable
J15	position 2-3 3 2 1	serial channel 1: RS485 configuration
	position 1-2 3 2 1	serial channel 1: RS422 configuration (not used)
Jumper	Position	Function
J16	position 2-3 1 2 3	serial channel 1: RS485 configuration
	position 1-2 1 2 3	serial channel 1: RS422 configuration (not used)
J19	position 2-3 1 2 3	serial channel 2: RS485 configuration
	position 1-2 1 2 3	serial channel 2: RS422 configuration (not used)
J20	position 2-3 1 2 3	serial channel 2: RS485 configuration
	position 1-2 1 2 3	serial channel 2: RS422 configuration (not used)

6.7.2 EP00047 and EP00051

Figure 28: Printed Circuit Board (PCB)

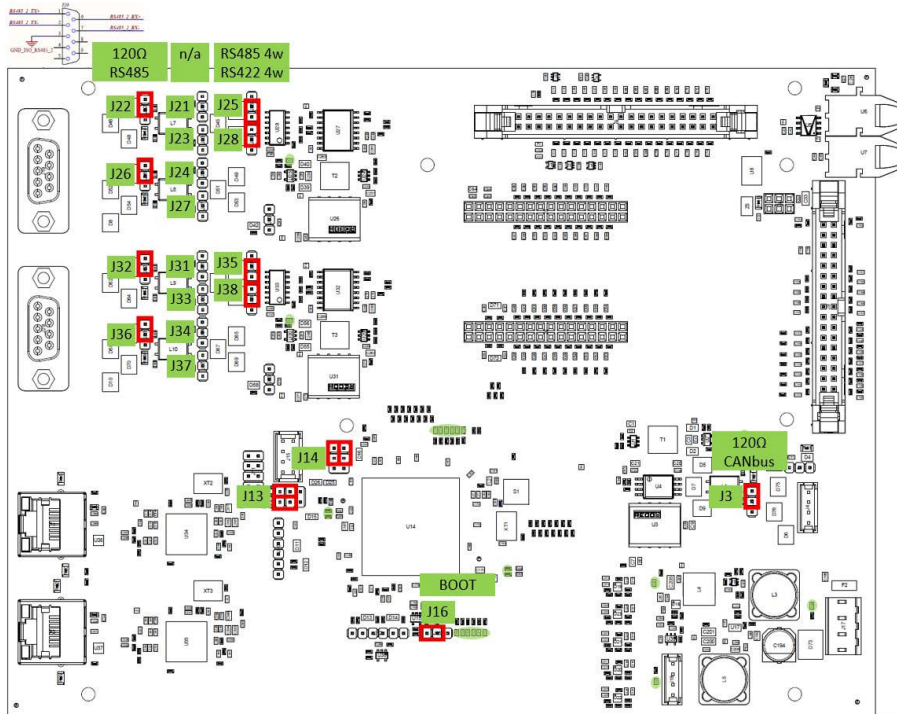

Bus A		Bus B		CAN		μProc	
J22	120 Ohm RS485_2_TX+ (1-2)	J32	120 Ohm RS485_1_TX+	J3	120 Ohm CAN (1-2)	J16	Boot-GND (2-3)
J26	120 Ohm RS485_2_RX+	J36	120 Ohm RS485_1_RX+				
J25	RS485_2_RX+ (4w:2-3, 2w:1-2)	J35	RS485_1_RX+ (4w:2-3)				
J28	RS485_2_RX- (4w:2-3)	J38	RS485_1_RX- (4w:2-3)				
J14	RS485_2 (3-5, 4-6)	J13	RS485_1 (3-5, 4-6)				

6.7.3 Multiwire/J-Bus connection scheme

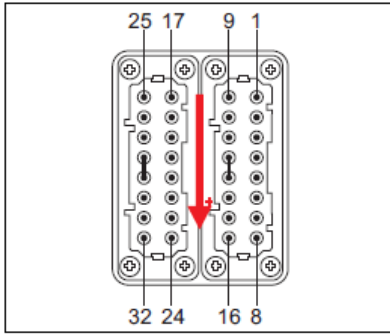

Note

The table shows the standard remote control configuration for the signals. If you want another configuration, contact ADB Safegate.

Table 14: Factory set terminal assignments for remote control connections with multiwire and single J-Bus (Cable Set 4072.30.XXX)

Function	Terminal number on 32-pole connector	Relay number on Remote Control PCB (unless indicated otherwise)
Control signals (fixed)		
Step 1 - CMD	1	J1.1
Step 2 - CMD	2	J1.2
Step 3 - CMD	3	J1.3
Step 4 - CMD	4	J1.4
Step 5 - CMD	5	J1.5
ON - CMD	6	J1.6
CCR OFF from HVCS - CMD	26	J1.7
NC	NC	J1.8
V-OUT 48V	15	J8.1
GND 48V	17	J8.2
CM – FB (general common relay return)	8	J8.3
CM – FB (general common relay return)	7, 18, J6.4	J8.4
	24	CRE doormswitch (power input door)
	26	CRE doormswitch (power input door)
	7	
Feedback signals (fixed)		
Step 1	9	J5.1
Step 2	10	J5.2
Step 3	11	J5.3
Step 4	12	J5.4
Step 5	13	J5.5
ON (step1,2...5) / OFF (OFF or Standby Step0)	19	J5.6

Table 14: Factory set terminal assignments for remote control connections with multiwire and single J-Bus (Cable Set 4072.30.XXX) (Continued)

Function	Terminal number on 32-pole connector	Relay number on Remote Control PCB (unless indicated otherwise)
Feedback signals (configurable via HMI): the values below are default values, for configuration options (for the options, see the table that follows)		
Disable local/remote (relay 7 for both connections)	14	J5.7 (NC relay)
	28	J5.8 (NO relay)
Open circuit - FB	16	J6.1
Overcurrent - FB	20	J6.2
Bad regulation	22	J6.3
	7, 18, J8.4	J6.4 (CM)
LFD alarm (Relay 11)	23	J6.5 (NO relay)
NC	NC	J6.6
EFD warning - FB	24	J6.7
EFD error - FB	25	J6.8
High temperature alarm - FB	27	J7.1
Short circuit - FB	29	J7.2
Lamp fault warning - FB (not used)	21	J7.3
	NC	J7.4
J-Bus interface (fixed)		
RS485 Bus A GND	30	DB9.3
RS485 Bus A +	31	DB9.1
RS485 Bus A -	32	DB9.2

Table 15: Factory set terminal assignments for remote control connections with multiwire dual J-Bus (Cable Set 4072.30.182)

Function	Terminal number on 32-pole connector	Relay number on Remote Control PCB (unless indicated otherwise)
Control signals (fixed)		
Step 1 - CMD	1	J1.1
Step 2 - CMD	2	J1.2
Step 3 - CMD	3	J1.3
Step 4 - CMD	4	J1.4
Step 5 - CMD	5	J1.5
ON - CMD	6	J1.6
CCR OFF from HVCS - CMD	7	J1.7
NC	8	J1.8
V-OUT 48V	25	J8.1
GND 48V	9	J8.2
Feedback signals (fixed)		
GND - FB	10	J8.3
GND - FB	NC	J8.4

Table 15: Factory set terminal assignments for remote control connections with multiwire dual J-Bus (Cable Set 4072.30.182) (Continued)

Function	Terminal number on 32-pole connector	Relay number on Remote Control PCB (unless indicated otherwise)
Step 1 - FB	11	J5.1
Step 2 - FB	12	J5.2
Step 3 - FB	13	J5.3
Step 4 - FB	14	J5.4
Step 5 - FB	15	J5.5
ON (step1,2...5) / OFF (OFF or Standby Step 0 - FB)	16	J5.6
Feedback signals (configurable via HMI):		
Disable local/remote NC	NC	J5.7 (NC relay)
	NC	J5.8 (NO relay)
Open circuit - FB	17	J6.1
Overcurrent - FB	18	J6.2
Bad regulation	19	J6.3 (CM)
CM specific return for Relay 11	NC	J6.4
LFD alarm (Relay 11)	NC	J6.5 (NO relay)
NC	NC	J6.6
EFD warning - FB	20	J6.7
EFD error - FB	NC	J6.8
High temperature alarm - FB	NC	J7.1
Short circuit - FB	NC	J7.2
Lamp fault warning - FB	NC	J7.3
(not used)	NC	J7.4
J-Bus interface (fixed)		
RS485 Bus B GND	27	DB92.3
RS485 Bus B-	28	DB92.1
RS485 Data B+	29	DB92.2
RS485 Bus A GND	30	DB9.3
RS485 Data A -	32	DB9.2
RS485 Data A +	31	DB9.1

Figure 29: Multiwire and J-Bus connection

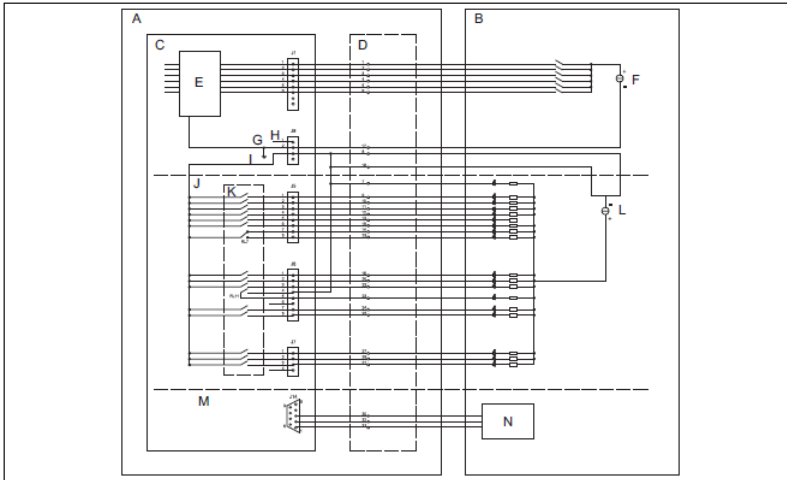

A	Equipment
B	Remote control equipment
C	Remote control PCB - input signals
D	Remote control connector on the equipment
E	Opto coupler
F	48 V DC power supply
G	Isoground
H	+48 V DC I Rel com
J	Remote control PCB - feedback signals
K	Relays
L	24 V DC power supply
M	J-Bus RS485 connection
N	J-Bus RS485 interface

Appendix A: SUPPORT

Our experienced engineers are available for support and service at all times, 24 hour/7 days a week. They are part of a dynamic organization making sure the entire ADB SAFEGATE is committed to minimal disturbance for airport operations.

ADB SAFEGATE Support

Technical Support – Global

Customers in Europe, the Middle East, Africa or Asia Pacific are more than welcome to our portal for technical support. Trained in all areas of system issues, troubleshooting, quality control and technical assistance, our highly experienced Technical support specialists are available 24 hours a day, seven days a week to provide assistance over the phone. In the Americas, we also offer live technical support.

Live Technical Support – Americas

If at any time you have a question or concern about your product, contact ADB SAFEGATE's US-based technical support specialists, available 24 hours a day, seven days a week, to assist you via phone.

ADB SAFEGATE Americas Technical Service & Support (US & Canada) :+1-800-545-4157

ADB SAFEGATE Americas Technical Service & Support (Canada): +1-905-631-1597

ADB SAFEGATE Americas Technical Service & Support (International): +1-614-861-1304

We can also be reached via email during regular business hours:

Airfield and Gate: techservice.us@adbsafegate.com

Gate: gateservice.us@adbsafegate.com

We look forward to working with you!

Before You Call

When you have an airfield lighting or system control system problem, prior to calling, please ensure the following:

- Review the product's manual and troubleshooting guide.
- Be located with the product ready to troubleshoot.
- Have all necessary information available: airport code/company name, customer id number, contact phone number/email address, product/part number.
- Have a *True RMS* meter available and any other necessary tools.

When calling about an issue with Safedock A-VDGS, we can serve you better if you collect the following information before you call:

- Relevant information regarding the issue you are calling about, such as gate number, flight number, aircraft type and time of the event.
- What, if any, actions have been taken to resolve the issue prior to the call.
- If available, provide a CCTV recording of the incident to aid in aligning the information from the Safedock log file.

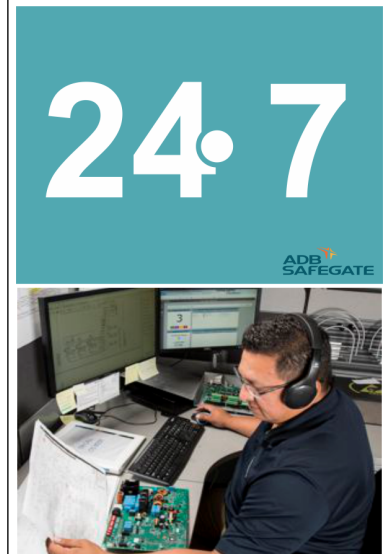

Note

For more information, see www.adbsafegate.com, contact ADB SAFEGATE Support via email at support@adbsafegate.com or

Europe: +32 2 722 17 11

Americas: +1 614 861 1304. Press 3 for technical service or press 4 for sales support.

China: +86 (10) 8476 0106

Middle East and Africa: +971 4 452 7575

A.1 ADB SAFEGATE Website

The ADB SAFEGATE website, www.adbsafegate.com, offers information regarding our airport solutions, products, company, news, links, downloads, references, contacts and more.

A.2 Recycling

A.2.1 ADB SAFEGATE Recycling

ADB SAFEGATE is fully committed to environmentally-conscious manufacturing with strict monitoring of our own processes as well as supplier components and sub-contractor operations. ADB SAFEGATE offers a recycling program for our products to all customers worldwide, whether or not the products were sold within the EU.

ADB SAFEGATE products and/or specific electrical and electronic component parts which are fully removed/separated from any customer equipment and returned will be accepted for our recycling program.

All items returned must be clearly labeled as follows:

- For *ROHS/WEEE* Recycling
- Sender contact information (Name, Business Address, Phone number).
- Main Unit Serial Number.

ADB SAFEGATE will continue to monitor and update according for any future requirements for *EU directives* as and when *EU member states* implement new *regulations* and or *amendments*. It is our aim to maintain our *compliance plan* and assist our customers.

A.2.1.1 Local Authority Recycling

The disposal of ADB SAFEGATE products is to be made at an applicable collection point for the recycling of electrical and electronic equipment. The correct disposal of equipment prevents any potential negative consequences for the environment and human health, which could otherwise be caused by inappropriate waste handling. The recycling of materials helps to conserve natural resources. For more detailed information about recycling of products, contact your local authority city office.



Powering Your Airport Performance from Approach to Departure

adbsafegate.com

Copyright © ADB SAFEGATE, all rights reserved

