



## Model 2040

### Ultrasonic Wind Sensor

PRODUCT MANUAL  
2040/Rev K

  
**ADB  
SAFEGATE**

## A.0 Disclaimer / Standard Warranty

### CE certification

The equipment listed as CE certified means that the product complies with the essential requirements concerning safety and hygiene. The European directives that have been taken into consideration in the design are available on written request to ADB SAFEGATE.

### ETL certification

The equipment listed as ETL certified means that the product complies with the essential requirements concerning safety and C22.2 No.180:13 (R2018) regulations. The CSA directives that have been taken into consideration in the design are available on written request to ADB SAFEGATE.

### All Products Guarantee

ADB SAFEGATE will correct by repair or replacement per the applicable guarantee below, at its option, equipment or parts which fail because of mechanical, electrical or physical defects, provided that the goods have been properly handled and stored prior to installation, properly installed and properly operated after installation, and provided further that Buyer gives ADB SAFEGATE written notice of such defects after delivery of the goods to Buyer. Refer to the Safety section for more information on Material Handling Precautions and Storage precautions that must be followed.

ADB SAFEGATE reserves the right to examine goods upon which a claim is made. Said goods must be presented in the same condition as when the defect therein was discovered. ADB SAFEGATE furthers reserves the right to require the return of such goods to establish any claim.

ADB SAFEGATE's obligation under this guarantee is limited to making repair or replacement within a reasonable time after receipt of such written notice and does not include any other costs such as the cost of removal of defective part, installation of repaired product, labor or consequential damages of any kind, the exclusive remedy being to require such new parts to be furnished.

ADB SAFEGATE's liability under no circumstances will exceed the contract price of goods claimed to be defective. Any returns under this guarantee are to be on a transportation charges prepaid basis. For products not manufactured by, but sold by ADB SAFEGATE, warranty is limited to that extended by the original manufacturer. This is ADB SAFEGATE's sole guarantee and warranty with respect to the goods; there are no express warranties or warranties of fitness for any particular purpose or any implied warranties of fitness for any particular purpose or any implied warranties other than those made expressly herein. All such warranties being expressly disclaimed.

### Standard Products Guarantee

Products manufactured by ADB SAFEGATE are guaranteed against mechanical, electrical, and physical defects (excluding lamps) which may occur during proper and normal use for a period of two years from the date of exworks delivery, and are guaranteed to be merchantable and fit for the ordinary purposes for which such products are made.

---

#### NOTE



See your applicable sales agreement for a complete warranty description.

Replaced or repaired equipment under warranty falls into the warranty of the original delivery. No new warranty period is started for these replaced or repaired products.

---

### FAA Certified products manufactured by ADB SAFEGATE

ADB SAFEGATE L858 Airfield Guidance Signs are warranted against mechanical and physical defects in design or manufacture for a period of 2 years from date of installation, per FAA AC 150/5345-44 (applicable edition).

ADB SAFEGATE LED products (with the exception of obstruction lighting) are warranted against electrical defects in design or manufacture of the LED or LED specific circuitry for a period of 4 years from date of installation, per FAA EB67 (applicable edition). These FAA certified constant current (series) powered LED products must be installed, interfaced and powered with and through products certified under the FAA Airfield Lighting Equipment Program (ALECP) to be included in this 4 (four) year warranty. This includes, but is not limited to, interface with products such as Base Cans, Isolation Transformers, Connectors, Wiring, and Constant Current Regulators.

### Revision History

Revision	Date	Summary of Changes
H	2013 Aug 1	Updated specifications for Model 2040HH
J	2014 June 25	Added connectorized wind sensors
K	2025 Apr 1	ADB SAFEGATE (ECP#ADBSG-0001)

# Contents

<b>1. Introduction.....</b>	<b>7</b>
1.1 Models.....	7
1.2 Accessories.....	7
<b>2. Fast-Track Setup.....</b>	<b>8</b>
<b>3. Pre-Installation.....</b>	<b>9</b>
3.1 Installation Requirements.....	9
<b>4. Installation.....</b>	<b>10</b>
4.1 Installation Guidelines.....	10
4.2 Bench System Test.....	10
4.3 Cabling.....	11
4.4 Connections.....	12
4.4.1 Connecting to a PC with an RS-422 or RS-485 Input.....	14
4.4.2 Networking Units.....	15
4.4.3 Connecting to a PCI Unit with RS-422 Input.....	16
4.4.4 PCI Connector Pin and Cable Assignments.....	17
4.4.5 RS-422 Network Out – 9 way Plug.....	19
4.5 Power Supplies.....	19
4.6 Mechanical Installation.....	20
4.6.1 Location.....	20
4.6.2 Orientation.....	20
4.6.3 Mounting Bracket.....	20
4.6.4 Alignment.....	22
<b>5. Message Formats &amp; Options.....</b>	<b>23</b>
5.1 Wind Speed Format.....	23
5.2 Output Formats.....	23
5.3 Networking.....	24
5.3.1 Proprietary Network.....	24
5.4 Units.....	25
5.5 Output Rate.....	25
5.6 Averaging Digital Data.....	25
5.7 Heating.....	25
5.7.1 45° Offset.....	25
5.8 ASCII Message Format (UV And Polar).....	26
5.8.1 ASCII UV Format.....	26
5.8.2 ASCII Polar Format.....	27
5.8.3 ASCII Polled (UV and Polar).....	28
5.9 NMEA Format.....	29
<b>6. Configuration.....</b>	<b>30</b>
6.1 Entering Configuration Mode.....	30
6.2 Returning To Measurement Mode.....	30

## Model 2040 Ultrasonic Wind Sensor

6.3 Checking The Configuration .....	30
6.4 Changing Settings .....	31
6.5 Output Formats.....	31
6.6 Unit Identifier.....	31
6.7 Units .....	31
6.8 Output Rate.....	32
6.9 Averaging.....	32
6.10 Options.....	32
6.10.1 Heating (If fitted).....	32
6.10.2 NMEA.....	32
6.10.3 Vertical Output Padding.....	32
6.10.4 45° Offset .....	33
6.11 Communications Settings.....	34
6.11.1 Baud Rate.....	34
6.11.2 Duplex Mode .....	34
6.11.3 Data and Parity Options .....	34
6.11.4 ASCII Message Terminator.....	35
6.12 Configuration and Diagnostic Information .....	35
6.13 Message Format (Output String Padding).....	35
6.14 New Unit Programming.....	35
<b>7. Maintenance &amp; Troubleshooting .....</b>	<b>36</b>
7.1 Cleaning.....	36
7.2 Servicing .....	36
7.3 Maintenance .....	36
7.3.1 Monthly Maintenance.....	36
7.3.2 Triannual Maintenance .....	36
7.3.3 Annual Maintenance .....	36
7.4 Troubleshooting.....	37
7.5 Returning Unit.....	37
7.6 Status (Error) Codes.....	37
7.7 Bench Test.....	38
7.7.1 Zero Wind Chamber.....	38
7.7.2 Integrity & Zero Wind Check .....	38
<b>8. Specifications .....</b>	<b>40</b>
<b>9. Warranty .....</b>	<b>43</b>
<b>Appendix A — Glossary &amp; Abbreviations .....</b>	<b>44</b>
<b>Appendix B — Principle Of Operation.....</b>	<b>46</b>

## **FOREWORD**

Thank you for purchasing the Model 2040 manufactured for ADB Safegate.

The unit has no customer serviceable parts and requires no calibration or maintenance.

To achieve optimum performance we recommend that you read the whole of this manual before proceeding with use. Do NOT remove black "rubber" transducer caps.

ADB Safegate products are in continuous development and therefore specifications may be subject to change and design improvements without prior notice.

The information contained in this manual remains the property of ADB Safegate, and should not be copied or reproduced for commercial gain.

# 1. Introduction

The ADB Safegate series of Model 2040 wind sensors is very robust and lightweight with no moving parts, outputting wind speed and direction. The units of wind speed, output rate and formats are all user selectable.

The Model 2040 wind sensors are available with or without deicing heating (recommended if icing is likely).

The Model 2040 wind sensors can be used in conjunction with a PC, datalogger or other device, provided it is compatible with the RS-422 output. Multiple units can be networked if required.

The output message format can be configured in Polar, UV (2-axis), and NMEA (0183 Version 3) formats, and as either a Continuous output or Polled (requested by host system), detailed in full in **Chapter 5. Message Formats & Options.**

The Model 2040 wind sensors may be configured using standard communications software on a PC. This is explained in **Chapter 6. Configuration.**

## 1.1 Models

The following models are available. Select a cable from Section 1.2 to use with the Ultrasonic Wind Sensors that have a connector only for a separate cable; see Section 4.3 for more information about custom cable lengths.

Description	Part Number	
	10 m cable attached	Connector for separate cable
Ultrasonic Wind Sensor	2040	2040C
Heated Ultrasonic Wind Sensor	2040H	2040HC
Ultrasonic Wind Sensor with High Heat	2040HH	2040HHC

## 1.2 Accessories

The following accessories are available for the Model 2040 series of Ultrasonic Wind Sensors.

Part Number	Description
M105548-00	Zero Wind Chamber
M488270-01	Corrosion-Resistant Mounting Kit
M488302-00	Mounting Bracket for Pole Mounting
M493080-00	30 m (100 ft) cable for wind sensors with connectors
M493104-00	20 m (70 ft) cable for wind sensors with connectors
M493081-00	10 m (35 ft) cable for wind sensors with connectors

## 2. Fast-Track Setup

If you are in a hurry to try out the Model 2040, are familiar with ADB Safegate equipment, and coupling to a PC using RS-422, go to the following chapters.

Chapter 4. Installation

Chapter 5. Message Formats & Options

Chapter 6. Configuration

After you have successfully set up the ultrasonic wind sensor, we strongly advise that you then go back and read the rest of the manual to ensure that you get the best results from the ultrasonic wind sensor.

## 3. Pre-Installation

### 3.1 Installation Requirements

Host system — One of the following:

- » PC with an internal or external interface compatible with the RS-422 output from the Model 2040.
- » Other equipment with I/O compatibility to the Model 2040 option selected.  
For example, if the unit has a Data Logger, Chart Recorder, or PC fitted with an ADC card.
- » Networking Multiple Model 2040 units can be networked

Software — One of the following:

- » Hyperterminal (for Windows® 9x and later), or Terminal (Windows® 3.n), normally already installed on a PC.
- » Other Terminal Emulation software packages.

#### *Cable and Junction Box*

A cable is used to connect the ultrasonic wind sensor and the host system. A mast mounted junction box (not provided) is required for onward connection.

See Section 4.4 for connection details.

The cable from sensors without a connector must be retained with a cable tie within 150 mm of the base of the ultrasonic wind sensor.

#### *Mounting Bracket*

A mounting bracket (not provided) is required to attach to the ultrasonic wind sensor via the four tapped holes in the base of the unit. Always ensure that the gasket supplied is fitted to the base of the ultrasonic wind sensor.

It is important that the gasket supplied forms a water tight seal on the base of the ultrasonic wind sensor.

In the event that the mounting bracket supplied by the customer is not flat or does not form complete support for the ultrasonic wind sensor base, the customer must fit a mounting ring as shown in Figure 2.

See Section 4.6 for mounting details.

## 4. Installation

---

### IMPORTANT



Do NOT remove the black “rubber” transducer caps. The warranty is voided if the blue security seal is damaged or removed.

All the time the ultrasonic wind sensor is not in its final location, it should be protected from damage by keeping it in the original packaging as long as possible, treating it as a delicate instrument. Take care not to knock the four transducer arms.

---

### 4.1 Installation Guidelines

The ultrasonic wind sensor has been designed to meet and exceed the stringent standards listed in its specification. Operating in diverse environments all over the world, the ultrasonic wind sensor requires no calibration or adjustment whatsoever.

As with any sophisticated electronics, good engineering practice should be followed to ensure correct operation.

- » Always check the installation to ensure the ultrasonic wind sensor is not affected by other equipment operating locally, which may not conform to current standards, e.g. radio/radar transmitters, boat engines, generators etc.

Guidelines —

- » Avoid mounting in the plane of any radar scanner — a vertical separation of at least 2 m should be achieved.
- » Radio transmitting antennas, the following minimum separations (all round) are suggested
  - VHF IMM – 1 m
  - MF/HF – 5 m
  - Satcom – 5 m (avoid likely lines of sight)
- » Ensure the product is correctly grounded in accordance with this manual
- » Use cables recommended by ADB Safegate, keeping the length below the maximum allowed (see Section 4.3) Where the cables are cut and reconnected (junction boxes, plugs and sockets) the cable screen integrity must be maintained, to prevent the EMC performance being compromised.
- » Ground loops should not be created – ground the system in accordance with the installation guidelines. (see Section 4.4)
- » Ensure the power supply operates to the specifications at all times.

Avoid turbulence caused by surrounding structures that will affect the accuracy of the ultrasonic wind sensor such as trees, masts and buildings. The World Meteorological Organisation makes the following recommendation:

- » The standard exposure of wind instruments over level open terrain is 10 m above the ground. Open terrain is defined as an area where the distance between the sensor and any obstruction is at least 10 times the height of the obstruction.

When installing the wind sensor, degrease the unit and hold it using lint free gloves to reduce the buildup of deposits.

### 4.2 Bench System Test

---

#### NOTE



Prior to physically mounting the ultrasonic wind sensor in its final location, we strongly recommend that a bench system test is carried out to confirm the system is configured correctly, is fully functional and electrically compatible with the selected host system and cabling (preferably using the final cable length). The required data format, units, output rate, and other options should also all be configured at this stage. If a Zero Wind Chamber has been purchased, refer to Section 7.7.

---

## 4.3 Cabling

### Cable Type

An RS-422 compatible cable should be used, with the number of twisted pairs matching the application.

**Generic Description** – Twisted pairs with drain wire, screened with aluminized tape, with an overall PVC sheath. Wire size 7/0.2 mm (24 AWG)

The table shows some suitable manufacturers' references; other manufacture's equivalents can be used.

No. of Pairs	Belden Ref.	Batt Electronics Ref.
2	9729	—
3	9730	91030
4	9728	91199
9	8774	91009

**Table 1. Cable Options**

ADB Safegate. offers three common cable lengths for the connectorized cable (see Section 1.2).

### Maximum Cable Length

The typical maximum length at 9600 baud is 1 km (3200 ft), using the recommended cable. If any problems of data corruption are experienced (due to, for example, a high local electrical 'noise' level), then a lower baud rate should be used. Alternatively, a thicker or higher specification cable can be tried.

### Cabling and Junction Box

The ultrasonic wind sensor is either fitted with a 10 m cable attached or with a separate connectorized cable available in multiple lengths. Custom length cables may also be used with the connectorized cable option. The cable must be terminated in a suitable terminal box to IP66 or better, and fitted with glands to prevent moisture ingress.

The cable type from the terminal box to the host system must be as specified above. If any cable is likely to be exposed to mechanical damage, it must be enclosed in a suitable conduit or cable tray. The cable must be securely fixed with cable clamps or equivalent, such that the cable is not under stress at the cable glands.

The gland area at the base of the ultrasonic wind sensor should not be directly exposed to moisture, as whilst the gland is sealed when mated, the ultrasonic wind sensor is vented to air at the base to avoid pressure build up. If an IP66 rating is essential or the unit is mounted other than 'right way up' use the gasket provided in the mounting kit.

## 4.4 Connections



### IMPORTANT

Do NOT join any of the cores of the cable together. Joining cores could damage the unit permanently. Any cores not used should be isolated.

Do NOT connect the unit's 0 V, Heater or digital 0 V to the screen or ground.

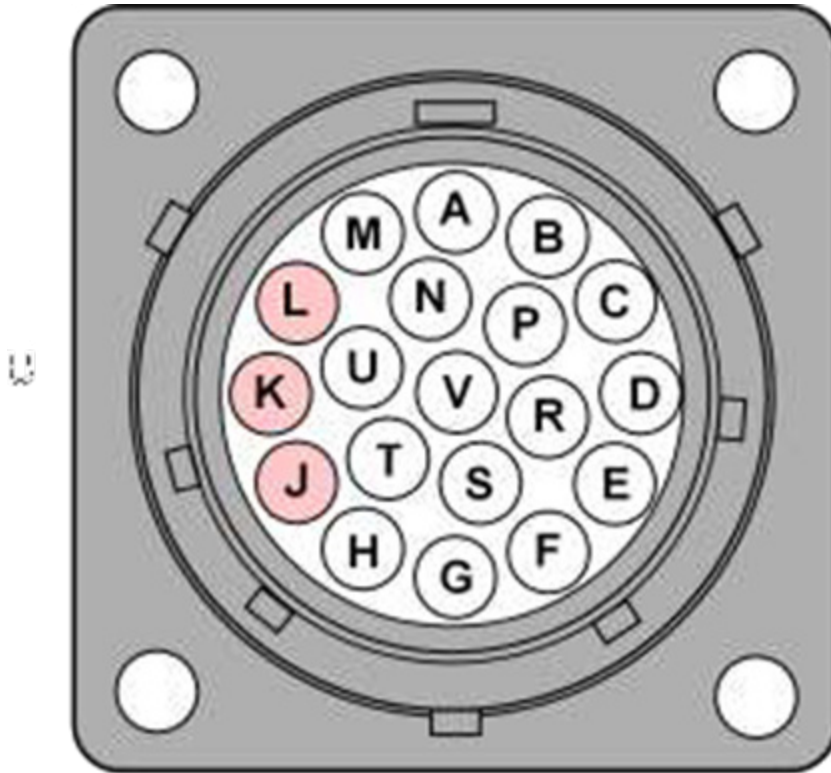

**Figure 1. Socket Pinout for Model 2040C/2040HC/2040HHC Wind Sensors**

Figure 1. shows the pinout for the ultrasonic wind sensors with a connector, which has a socket for a separate cable. The other ultrasonic wind sensor models have the cable wired directly to them through a gland. The screens of each pair are joined together inside the sensor — these should be joined to the cable screen(s) of any further cable run. Avoid long grounding loops. Digital 0 V should be used in conjunction with RS-422 TX RX lines in order to improve noise immunity. Each pair in the cable is labeled with its pair number.

Connector Socket Pin	Conductor	Color	Designation	
P	Pair 1	green	RS-422_TXB (+)	
C		black	RS-422_TXA (-)	
U	Pair 2	white	RS-422_RXB (+)	
V		black	RS-422_RXA (-)	
R	Pair 3	red	Supply V+	
D		black	Supply V-	
M	Pair 4	blue	Digital 0v	
N		black	Not used (isolate)	
A	Pair 5	yellow	Heater+ *	2040H, 2040HC, 2040HH, 2040HHC
B		black	Heater- *	
H	Pair 6	brown	Heater+ *	2040HH, 2040HHC
G		black	Heater- *	
E	Pair 7	orange	Heater+ *	2040HH, 2040HHC
F		black	Heater- *	
T†	Pair 8	white	Not used (isolate)	
S†		red	Not used (isolate)	
L†	Pair 9	green	Not used (isolate)	
K†		red	Not used (isolate)	
	Screens		Chassis ground	

\* May not be functional – used with wind sensors that have one or more heaters as listed.

† These pins and Pin J are not connected to wires on the M493080 -00 and M493081-00 cables

**Table 2. Cable Wiring Information**

### Grounding

To ensure correct operation, and for maximum protection against lightning, the ultrasonic wind sensor **MUST** be correctly grounded via its mountings. Inadequate grounding will degrade sensor performance, particularly in the presence of radio frequency interference.

See Figure Figure 2. Suggested Mounting Bracket and Grounding Arrangements

The unit **MUST** be connected to an appropriate grounding point with a minimum of 6 mm<sup>2</sup> copper wire, via the M5 base screws. The cable screens must be joined with any cable screen continuing from the unit's cable via a junction box. The primary ground for the ultrasonic wind sensor must be provided via the base screws and not via the cable screens.

#### 4.4.1 Connecting to a PC with an RS-422 or RS-485 Input

The PC requires either an internal RS-422 interface card or an external RS-422/485 to RS-232 converter that will plug into the standard 9-way or 25-way RS-232 serial port of the PC or host equipment.

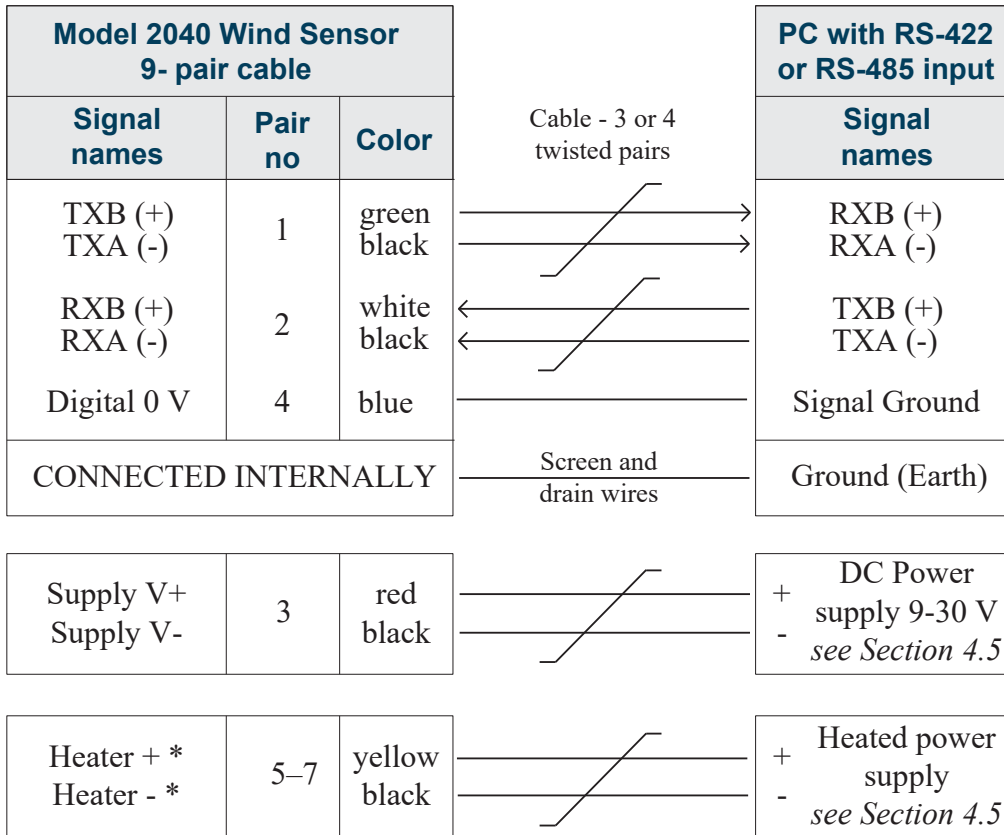

\* If unit is fitted with a heater



#### NOTE

Heater pair wires yellow, brown, and orange should be connected in parallel, as should the three return black wires. The number of heater wire combinations depends on the exact Model 2040 model number.

### 4.4.2 Networking Units

Before coupling units into a network:

- » Each device must be configured with a unique Unit Identifier (letter B to Z)
- » It must be configured to a tri state polled mode **M3** or **M4**.

See Chapter 6. - Configuring

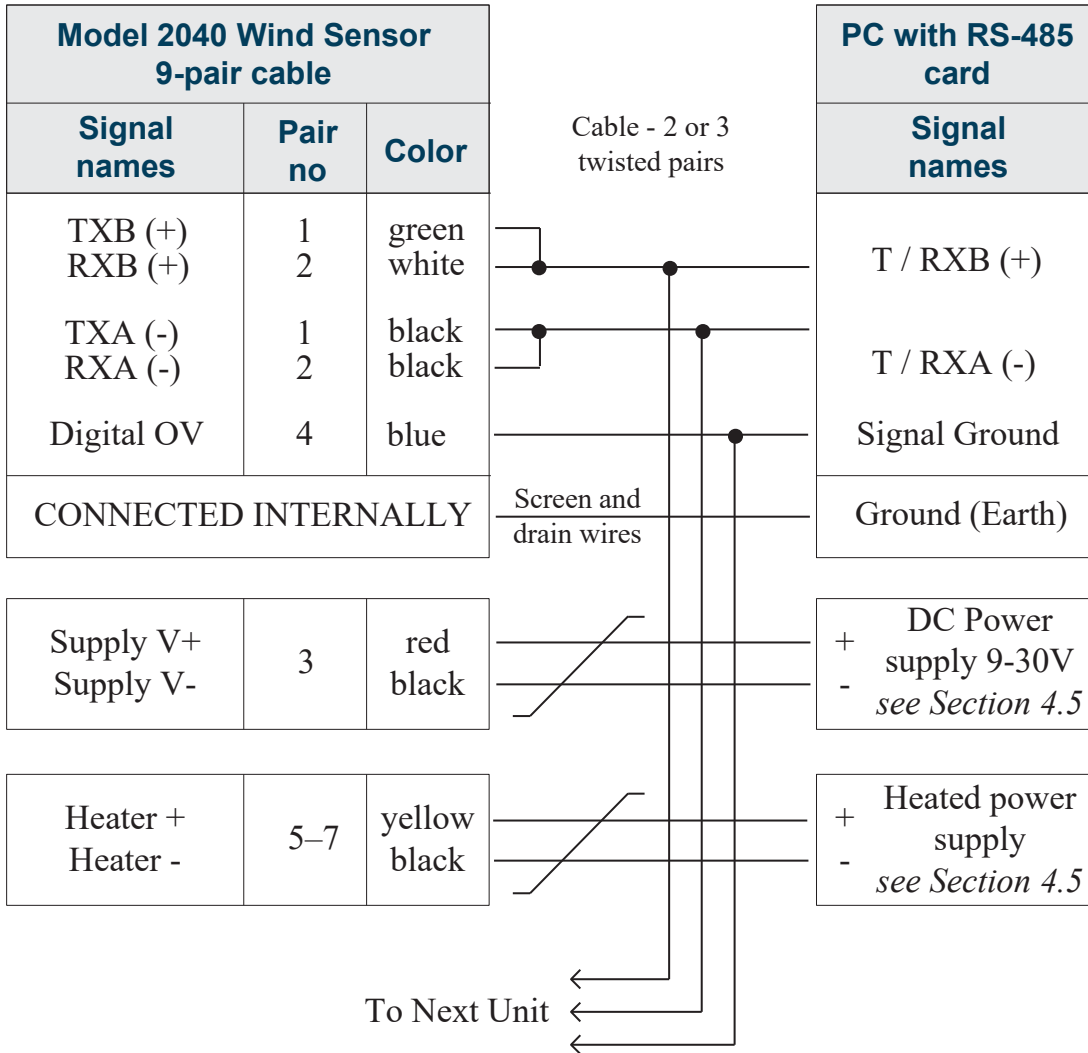

**NOTE**

Heater pair wires yellow, brown, and orange should be connected in parallel, as should the three return black wires. The number of heater wire combinations depends on the exact Model 2040 model number.



**NOTE**

Each unit in the network will require its own power supplies. Please refer to Section 4.5.

**4.4.3 Connecting to a PCI Unit with RS-422 Input**

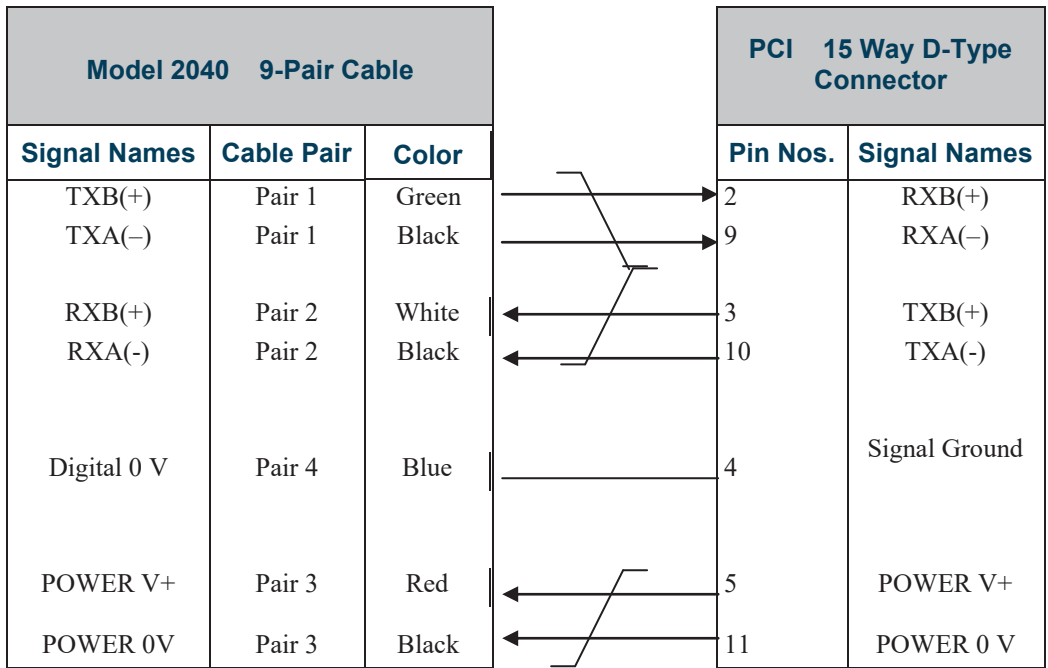

#### 4.4.4 PCI Connector Pin and Cable Assignments

Sensor connector – 15 way	
Pin	Designation
1	Chassis
2	RS-422_RXB (+)
3	RS-422_TXB (+)
4	Digital 0 V, Signal ground
5	Supply V+
6	Analog output V1
7	Not used
8	Analog output V2
9	RS-422_RXA (-)
10	RS-422_TXA (-)
11	Supply V-
12	Analog output V4
13	Not used
14	Not used
15	Analog output V3

DC Supply – 4 way	
Pin	Designation
1	Interface V+
2	Interface V-
3	Sensor V-
4	Sensor V+

RS-232 Output – 9 way	
Pin	Designation
1	DCD
2	RX data
3	TX data
4	DTR
5	Signal Ground
6	DSR
7	RTS
8	CTS
9	RI

RS-422 Network In – 9 way Socket	
Pin	Designation
1	Not connected
2	Not connected
3	Not connected
4	RS-422_RXA (-)
5	Signal ground
6	RS-422_TXA (-)
7	RS-422_TXB (+)
8	RS-422_RXB (+)
9	Chassis

#### 4.4.5 RS-422 Network Out – 9 way Plug

Pin	Designation
1	Not connected
2	Not connected
3	Not connected
4	RS-422_RXA (-)
5	Signal ground
6	RS-422_TXA (-)
7	RS-422_TXB (+)
8	RS-422_RXB (+)
9	Chassis

## 4.5 Power Supplies

### Sensor Power

Voltage	9 to 30 V DC
Current	60 mA max. 50 mA average

### Heater

If included, the heating module requires a separate power supply.

Either

22 – 30 V DC @ 3 A (Model 2040H/2040HC) or 7 A (Model 2040HH/2040HHC)  
 or 24 V AC rms  $\pm$  10% @ 3 A AC rms or 7 A rms depending on model as above



#### NOTE

The AC Supply must be isolated from the Mains Supply

## 4.6 Mechanical Installation

Before installing, a bench system test is recommended (see Section 4.2).

All the time the ultrasonic wind sensor is not in its final location, it should be protected from damage by keeping it in the original packaging as long as possible, treating it as a delicate instrument.

### 4.6.1 Location

It is important to ensure that the ultrasonic wind sensor is mounted in a position clear of any structure which may obstruct the airflow or induce turbulence.

Do NOT mount the ultrasonic wind sensor in close proximity of high-powered radar or radio transmitters. A site survey may be required if there is any doubt about the strength of external electrical noise. (See Section 4.1)

### 4.6.2 Orientation

Normally the ultrasonic wind sensor is mounted vertically with the cable exit at the bottom.

Alternatively, the unit may be mounted in any orientation, but note that if the unit is mounted with the cable uppermost, the gasket provided in the mounting kit must be used.

### 4.6.3 Mounting Bracket

A suggested mounting bracket is shown in Figure 2.

It is recommended that the mounting bracket is manufactured from 316 stainless steel to prevent possible galvanic corrosion.

It is also recommended that the supplied gasket is always fitted to ensure IP66 rating and to prevent galvanic corrosion if the mounting bracket is not manufactured from 316 stainless steel.

Fittings made from 316 stainless steel must be used.

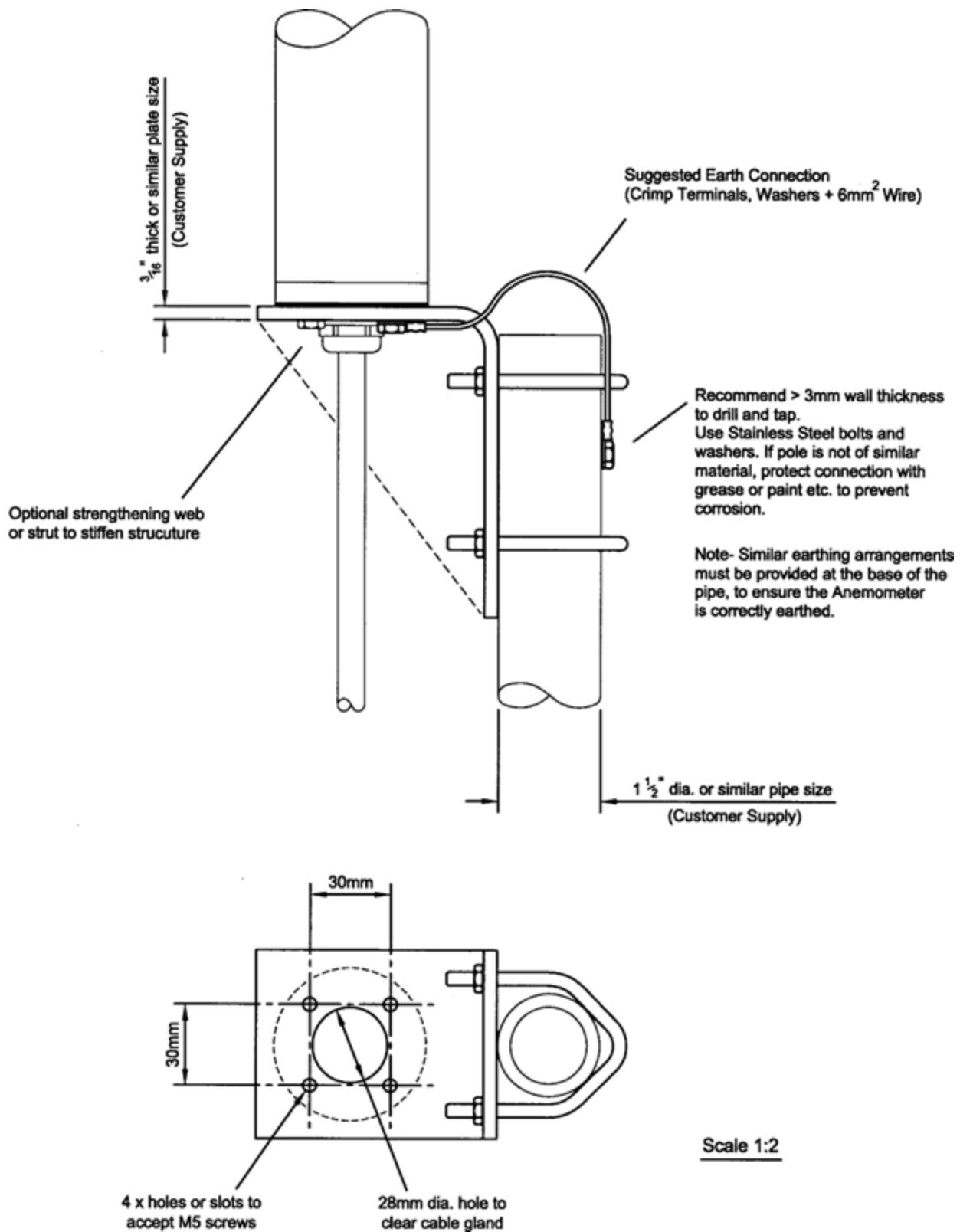

Figure 2. Suggested Mounting Bracket and Grounding Arrangements



## 5. Message Formats & Options

On first applying power, the ultrasonic wind sensor will be in 'Measurement Mode', and it will output wind measurement information in one of nine configurations as described below.

Setting the output format, units, other parameters, options and the communication settings are all carried out in the alternative 'Configuration Mode'.

See Chapter 6, Configuration, for details of how this is done.

The factory default settings are shown here in bold, and for convenience some 'Configuration codes' (as used to set the configuration) are shown in blue boxes, for example **M3**.

### 5.1 Wind Speed Format

The wind speed measurements can be output in one of the following formats:

UV, Polar, NMEA, or Tunnel (Models 2040 and 2040H).

### 5.2 Output Formats

The UV and Polar wind speed parameters are output in either ASCII or binary.

These parameters can be transmitted continuously or polled from the user.

Polar is also available in continuous NMEA format.

Output	Format	Output	Tri-state O/P	Configuration Code
ASCII	UV	Continuous	No	<b>M1</b>
		Polled	Yes	<b>M3</b>
ASCII	Polar	Continuous	No	<b>M2</b>
		Polled	Yes	<b>M4</b>
NMEA		Continuous	No	<b>M5</b>

**Table 3. Output Formats**

## 5.3 Networking

### 5.3.1 Proprietary Network

Each ultrasonic wind sensor connected to the network **MUST** be given a unique Unit Identifier (Letters A to Z), and set to a polled tri state mode (UV or Polar) **(M3 or M4)**.

In these modes the communications transmit line is tri state unless the wind sensor is responding to a command. If used in a multi drop system then it is recommended that Unit Identifiers A, B, C, D, E, F, K, M, N and P are not used.

#### Configuring Model 2040 for Half-Duplex Operation

1. Set up two terminals—one for RS-485 Half Duplex and the other for RS-422 Full Duplex. One PC (with two USB ports) can be used for both terminals, although two may be less confusing.



#### NOTE

Power must not be disconnected from the ultrasonic wind sensor throughout this procedure.

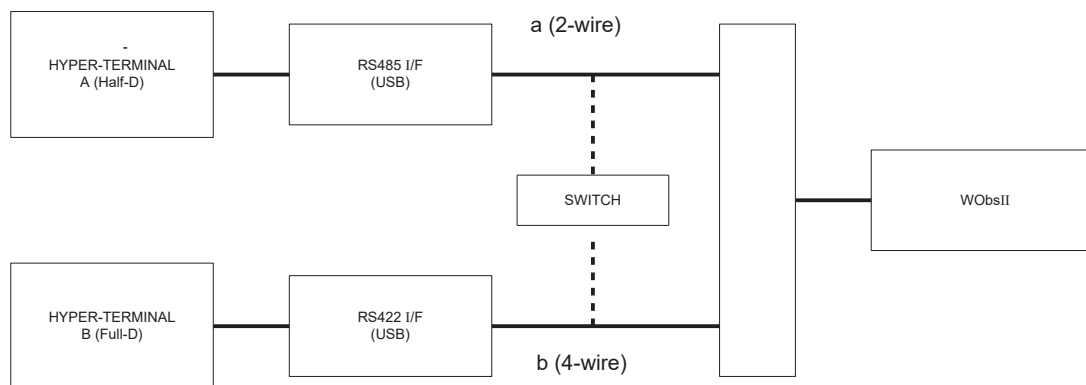

2. Assuming the unit is set for Full Duplex, connect 9-way at [b] disconnect 9-way at [a]. Set Switch to position [b] (4 wire).
3. On Terminal B, enter CONFIGURATION MODE. Set Half Duplex (E2). The CONFIRM> prompt will appear.
4. Disconnect 9-way [b] and connect 9-way [a]. Set Switch to position [a] (2 wire).
5. On Terminal A, type "E" <ENTER> to confirm.
6. The unit should now be configured in Half Duplex mode.

#### Configuring Model 2040 for Full-Duplex Operation

1. Assuming the unit is set for Half Duplex, disconnect 9-way [b] and connect 9-way [a]. Set Switch to position [a] (2 wire).
2. On Terminal A, type "E1" to select Full Duplex. The CONFIRM> prompt will appear.
3. Disconnect 9-way [a] and connect 9-way [b]. Set Switch to position [b] (4 wire).
4. On Terminal B type "E" <ENTER> to confirm.

## 5.4 Units

The wind speed can be set to any of the following units:

Unit	Abbreviation
Metres per sec	m/s
Knots	knots
Miles per hour	mph
Kilometers per hour	km/h
feet per minute	ft/min

## 5.5 Output Rate

The output frequency can be set between 1 and 4 per second. The wind speed is sampled every 25 ms, each axis being sampled sequentially. The following table lists the possible outputs per second and the corresponding number of averaged samples. A 25 ms sample period is used to process and output the results.

Outputs per Second	Sample Average
1	39
2	19
4	9

## 5.6 Averaging Digital Data

The Averaging Period can be set from zero to 3600 seconds (1 hour). The default setting is zero. When averaging is enabled, data is output at a rate determined by the averaging period. The data is an average of valid data collected during the averaging period.

## 5.7 Heating

Heating is autonomous and requires no set-up once activated.

Upon unit switch on if heating is enabled and heater power available then a 1 minute burst of heating will occur to give confidence that the heating is functioning.



### CAUTION

When heating is activated the bullet and transducer arms will get very hot and should not be handled.

### 5.7.1 45° Offset

If required, the U axis can be offset +45° to the transducer axis.

## 5.8 ASCII Message Format (UV And Polar)

### 5.8.1 ASCII UV Format

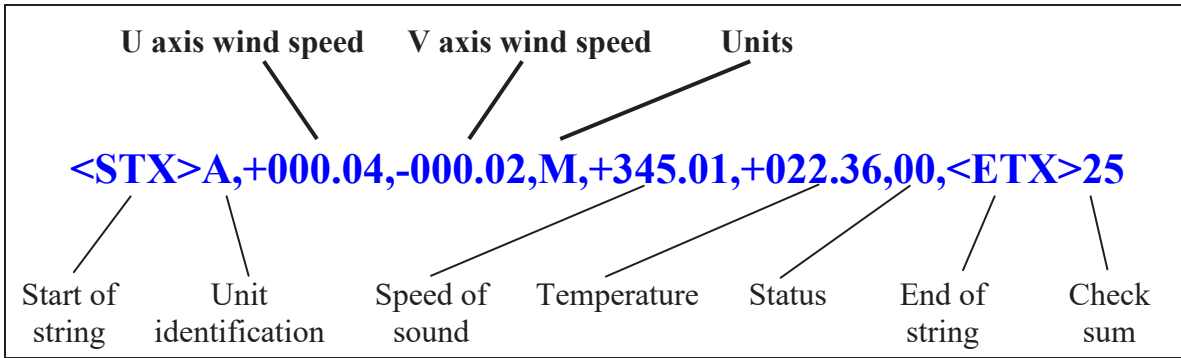

where

**U axis wind speed** In increments of 0.01 units ( $\pm$ UUU.UU)

**V axis wind speed** In increments of 0.01 units ( $\pm$ VVV.VV)

<b>Units</b>	<b>Value</b>	<b>Units</b>
	M	metres per second (m/s)
	N	knots (knots)
	P	miles per hour (MPH)
	K	kilometers per hour (km/h)
	F	feet per minute (ft/min)

**Start of string** ASCII value 2

**Unit identification** Letter A – Z (**default A**)

**Speed of sound** In metres per second (if enabled)

**Temperature** Sonic temperature in degrees C (if enabled)

<b>Status</b>	<b>Value</b>	<b>Status</b>
	0	OK
	60	<b>HEATING ENABLED AND OK IF ENABLED</b>
	Any other value	Warning or fault condition - see Section 7.6

**End of string** ASCII value 3

**Check sum** Exclusive OR of all characters between Start of String and End of String reported as ASCII hex.

### 5.8.2 ASCII Polar Format

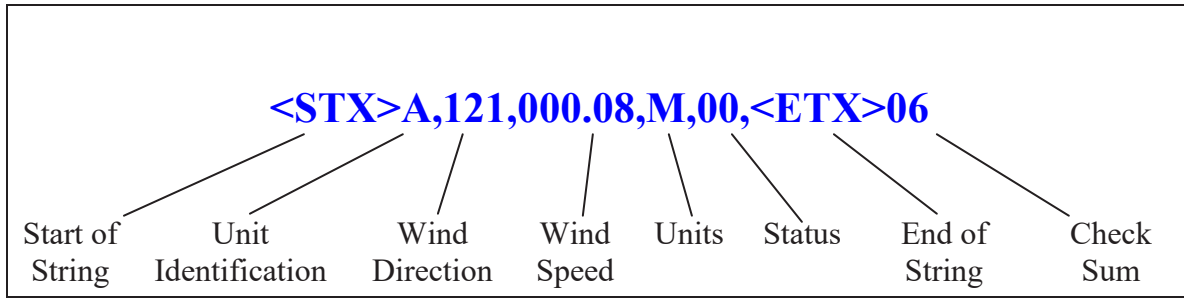

where

<b>Wind direction</b>	In degrees relative to N (DDD)	
<b>Wind speed</b>	In increments of 0.01 units ( $\pm$ MMM.MM)	
<b>Units</b>	Value	Units
	M	metres per second (m/s)
	N	knots (knots)
	P	miles per hour (MPH)
	K	kilometers per hour (km/h)
	F	feet per minute (ft/min)
<b>Start of string</b>	ASCII value 2	
<b>Unit identification</b>	Letter A – Z ( <b>default A</b> )	
<b>Status</b>	<b>Value</b>	<b>Status</b>
	0	OK
	60	<b>HEATING ENABLED AND OK IF ENABLED</b>
	Any other value	Warning or fault condition - see Section 7.6
<b>End of string</b>	ASCII value 3	
<b>Check sum</b>	Exclusive OR of all characters between Start of String and End of String reported as ASCII hex.	

### 5.8.3 ASCII Polled (UV and Polar)

When in the Polled mode, an output is only generated when the host system sends a Poll signal to the wind sensor consisting of the Unit Identifier – that is, the relevant letter A – Z.

The output formats are otherwise as described above.

The commands available in this mode are as follows.

Description	Command	Wind Sensor Response
Wind Sensor Unit Identifier	A – Z	Wind speed
Poll Mode Enabled	?	None
Poll Mode Disabled	!	None
Request Wind Sensor Unit Identifier	&	A – Z (as configured)
Enter Configuration Mode	*<N>	Configuration Mode

Where <N> is the unit identifier then it is recommended that IDs A to F and KMNP are not used when the wind sensor is used in a multi drop system as these characters can be present in the data string.

It is suggested that the following sequence is used in the polled mode for every poll for information.

- ? Ensures that the wind sensor is enabled to cover the event that a power down has occurred.
- A – Z Appropriate unit designator sent to retrieve a line of data.
- ! Sent to disable poll mode and reduce the possibility of erroneous poll generation.

When in polled mode, the system will respond to the data command within 30 ms with the last valid data sample as calculated by the Output rate (P Mode Setting).

If the unit is powered down after use or upon switch on, allow 3 seconds from switch on before sending poll commands.

## 5.9 NMEA Format

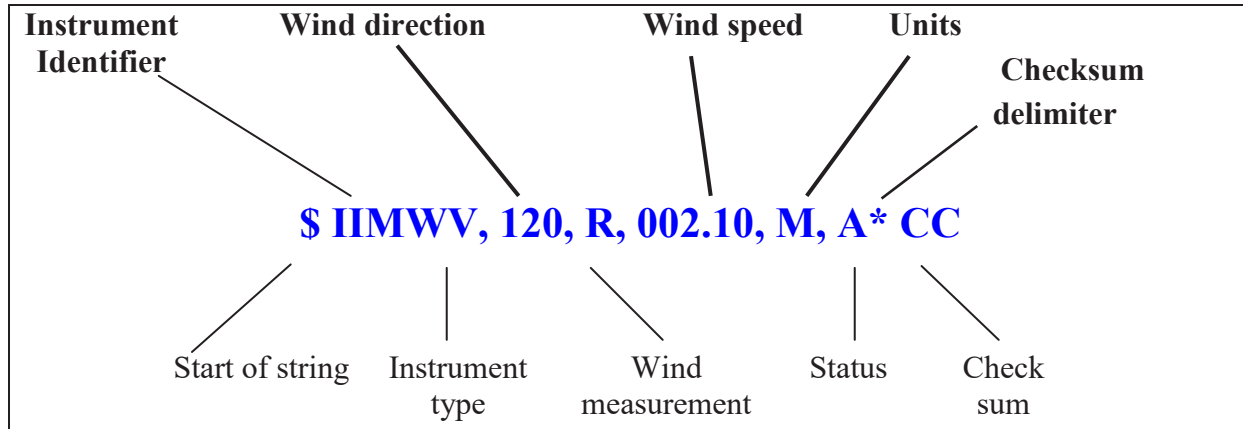

where

<b>Wind direction</b>	In degrees relative to N (DDD)
<b>Wind speed</b>	In increments of 0.01 units (±MMM.MM)
<b>Units</b>	M metres per second (m/s) N knots (knots) P miles per hour (MPH) K kilometers per hour (km/h) F feet per minute (ft/min)
<b>Start of string</b>	\$
<b>Instrument type</b>	IIMWV
<b>Wind measurement</b>	R Relative wind measurement
<b>Status</b>	A Valid measurement V Invalid measurement
<b>Check sum</b>	Exclusive OR of all characters between '\$' and '*' reported as ASCII hex.

A typical Model 2040 Ultrasonic Wind Sensor configuration suitable for NMEA would be:

B2, E1, F1, G0, K1, L1, M5, O1, P1, U1.

Consult specification NMEA 0183 version 3 (available on the web) [www.nmea.org](http://www.nmea.org) for complete interface details.

## 6. Configuration

Terminal emulator software such as Hyperterminal or Terminal is used to configure the Model 2040 Ultrasonic Wind Sensor.

The Model 2040 Ultrasonic Wind Sensor connects to an RS-422 to RS-232 adapter in the DCP. To perform the configuration described in this chapter, disconnect the serial DB-9 connector on that adapter and hook your laptop serial port to the adapter instead. Reconnect the serial DB-9 connector on that adapter once the configuration has been completed.

This section describes the commands used to change settings when using terminal emulator software. For a fuller description of the settings and options see Chapter 5.

Keystrokes are shown thus :- **D3 ENTER**

### 6.1 Entering Configuration Mode

#### From Continuous mode

**\***

#### From Polled mode

**\*N** where N is the Unit Identifier.

*Note - the Unit Identifier must be entered as upper case*

The Model 2040 Ultrasonic Wind Sensor responds with a CONFIGURATION MODE message, stops reporting wind measurements, and waits for a command (as detailed below).

### 6.2 Returning To Measurement Mode

**Q ENTER**

If in Continuous mode, the ultrasonic wind sensor responds with wind measurements immediately, continuing at the selected Sampling rate.

If in Polled mode,

- ?** Enables poll
- N** Polls ultrasonic wind sensor (where N is the Unit identifier entered as upper case)  
The ultrasonic wind sensor replies with a single set of wind measurements
- &** Ultrasonic wind sensor replies with Unit identifier
- !** Disables poll



#### NOTE

If the unit is in Polled Mode it is always best to interrogate the unit for data with a **?** before the poll identifier to cater for the event that the power has been switched off or power interrupted.

### 6.3 Checking The Configuration

Use the **D3** command prior to and after changing any settings. It shows the current settings for all the alterable settings. Note down these settings for future reference.

- \*** Enters Configuration Mode (from Continuous mode) or
- \*N** Enters Configuration Mode (from Polled mode)
- D3 ENTER** The Model 2040 responds with the current settings.

The factory default settings for a heated unit are

**A0 B3 C1 E1 F1 G0000 H2 J1 K1 L1 M2 NA O2 P1 T1 U2 V1 X1 Y1 Z1**

The following sections explain how to change these settings.

To return to Measurement mode **Q ENTER**

## 6.4 Changing Settings

To change a setting, first go into Configuration mode and then refer to the sections below. Enter the Configuration code of the new setting required, followed by **ENTER**.

If successful, the new setting will be echoed back as a message by the wind sensor.

For example, to change the message format to NMEA, enter **M5 ENTER**

The wind sensor will reply with will be in NMEA format. **M5**. When the unit is returned to the Measurement mode, it will be in NMEA format.



### NOTE

The factory set (default) settings are shown in bold in the following sections.

## 6.5 Output Formats

Output format	Configuration Code
ASCII UV Continuous	<b>M1</b>
ASCII UV Polled (tri-state) *	<b>M3</b>
ASCII Polar Continuous	<b>M2</b>
ASCII Polar Polled(tri-state) *	<b>M4</b>
NMEA Continuous	<b>M5</b>

\* If units are to be networked, they MUST be given unique Unit Identifiers (see Section 6.6 Unit Identifier)

## 6.6 Unit Identifier

**NX** Changes the Unit Identifier to 'X'.  
'X' can be any letter from A to Z.



### NOTE

The default Unit Identifier A should not be used when networking units.

## 6.7 Units

<b>Units</b>	metres/sec (m/s)	knots (knots)	miles / hour (MPH)	kilometers/hour (km/h)	feet/minute (ft/min)
<b>Configuration Code</b>	<b>U1</b>	<b>U2</b>	<b>U3</b>	<b>U4</b>	<b>U5</b>

## 6.8 Output Rate

Outputs per second	1	2	4	5	8	10
Configuration Code	<b>P1</b>	<b>P3</b>	<b>P2</b>	<b>P4</b>	<b>P5</b>	<b>P6</b>

## 6.9 Averaging

Setting	Configuration Code
Averaging (Default)	<b>G0000</b>

Enter the required averaging period in seconds as a four-figure number between 0000 and 3600.

## 6.10 Options

### 6.10.1 Heating (If fitted)

Heating is autonomous and requires no set up once activated.

Setting	Configuration Code
<b>Disabled</b>	<b>H1</b>
Activated Activated	<b>H2</b>
ASCII Polar Continuous	<b>H3</b>

Each transducer is heated independently and will be active when the ambient temperature drops below approximately +15°C; each transducer will de activate when +25°C threshold is reached.

### 6.10.2 NMEA

Setting	Configuration Code
<b>NMEA string "IIMWV"</b>	<b>K1</b>
NMEA string "WIMWV"	<b>K2</b>

### 6.10.3 Vertical Output Padding

Setting	Configuration Code
<b>Disable vertical output padding</b>	<b>V1</b>
Enable vertical output padding	<b>V2</b>

**6.10.4 45° Offset**

Setting	Configuration Code	Notes
<b>Align U axis with transducer axis</b>	<b>X1</b>	<b>X1. Aligns U axis with North/South axis.</b>
Align U axis +45° to transducer axis	X2	X2. This re aligns both U&V and polarity 45°.
Reverses Polar Direction	X3	X3 reverses reported polar direction to allow the instrument to be mounted upside down. N.B. Does NOT affect UV alignment (Mode 1, 3).
Align @ 45° from North	X4	X4 set UV & polar alignment at 45 degrees from North when instrument is mounted upside down.

Figure 4. shows the polarity of U and V if the wind components along the U and V axis are blowing in the direction of the respective arrows.

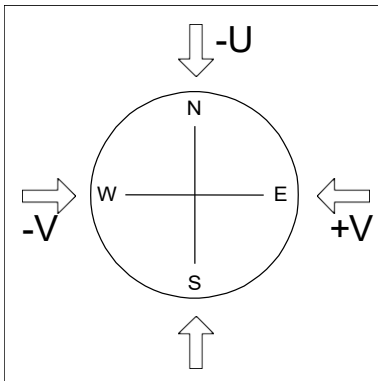

**Figure 4. UV Polarity**

## 6.11 Communications Settings

### 6.11.1 Baud Rate

Setting	Configuration Code
2400	<b>B1</b>
4800	<b>B2</b>
<b>9600</b>	<b>B3</b>
19200	<b>B4</b>
38400	<b>B5</b>
1200	<b>B6</b>
300	<b>B7</b>

If a request is sent to change the Baud rate, before it changes it must be confirmed by entering **B ENTER** (at the new Baud rate.)

eg. If set to B3 (9600 baud), to change to B5 (38400 baud), enter **B 5 ENTER** change host terminal to 38400 baud, and confirm by entering **B ENTER**



#### NOTE

Random echo will be generated after the B5 confirmation

### 6.11.2 Duplex Mode

Setting	Configuration Code
<b>Full duplex</b>	<b>E1</b>
Half duplex	<b>E2</b>

Note: Refer also to Section 5.3.

### 6.11.3 Data and Parity Options

Setting	Configuration Code
<b>8 bits, no parity, 1 stop bit</b>	<b>F1</b>
8 bits, even parity, 1 stop bit	<b>F2</b>
8 bits, odd parity, 1 stop bit	<b>F3</b>
7 bits, no parity, 1 stop bit	<b>F4</b>
7 bits, even parity, 1 stop bit	<b>F5</b>
7 bits, odd parity, 1 stop bit	<b>F6</b>

### 6.11.4 ASCII Message Terminator

Setting	Configuration Code
CR LF	L1
LF	L2

## 6.12 Configuration and Diagnostic Information

Each of these commands causes a response from the Model 2040.

Item	Command Code	Typical Response
Type and serial No.	D1	E000694
Software version	D2	2.07
Unit configuration	D3	current configuration : A0 B3 C1 E1 F1 G0000 H1 J1 K1 L1 M2 NA O1 P1 T1 U1 V1 X1 Y1 Z1
Ultrasonic wind sensor power supply voltage	D5	+29.8
Integrity check	D6	

## 6.13 Message Format (Output String Padding)

Setting	Configuration Code
<b>Comma Separated Variable (CSV)</b>	O1
Fixed Field	O2

Example data string for CSV data changing to error status code condition.

```
A,235,000.77,M,00, 0A
A,,,M,04, 24
```

Example data string for Fixed Field data changing to error status code condition.

```
A,266,000.73,M,00, 08
A,999,999.99,M,04, 0A
```

## 6.14 New Unit Programming

If you order a replacement sensor, it should arrive programmed for your system. In the event your sensor loses its programming, follow the programming steps below to make the wind sensor work correctly.

1. Set terminal communications to 9600/8/N/1.
2. Output should show on screen each second.
3. Press "\*" then "ENTER" (puts sensor in CONFIGURATION MODE).
4. Press "H2" (if heated version) then "ENTER" to enable the heater.
5. Press "U2" then "ENTER" to put sensor into knots output.
6. Press "O2" then "ENTER" to enable fixed format output.
7. Press "Q" then "ENTER" to exit configuration mode.
8. Sensor should now be outputting to the screen each second.

## 7. Maintenance & Troubleshooting

### 7.1 Cleaning

If there is any buildup of deposit on the unit, it should be gently cleaned with a cloth, moistened with soft detergent. Solvents should not be used, and care should be taken to avoid scratching any surfaces. The unit must be allowed to defrost naturally after being exposed to snow or icy conditions, do NOT attempt to remove ice or snow with a tool.

Do NOT remove black "rubber" transducer caps.

### 7.2 Servicing

There are no moving parts or user serviceable parts requiring routine maintenance.

Opening the unit or breaking the security seal will void the warranty and the calibration.

In the event of failure, prior to returning the unit to ADB Safegate, it is recommended that :

- All cables and connectors are checked for continuity, bad contacts, corrosion etc.
- A bench test is carried out as described in Section 7.7.
- You contact ADB Safegate for advice

### 7.3 Maintenance

#### 7.3.1 Monthly Maintenance

No monthly maintenance is required with this sensor.

#### 7.3.2 Triannual Maintenance

During triannual maintenance:

- Check that the wind values being output are reasonable
- Verify that no errors are displayed at the DCP

#### 7.3.3 Annual Maintenance

During annual maintenance, perform a Field Zero Wind Check as described below. The Zero Wind Chamber consists of a split shell that opens into two halves placed around the wind sensor.

1. Insert the flat piece that is provided with the Zero Wind Chamber into one of the two Wind Chamber halves are that are placed around the Model 2040 wind sensor.
2. Place two halves of the Zero Wind Chamber around the Model 2040 wind sensor. Secure the chamber is in place with the strips provided.
3. View the wind speed value displayed at the DCP. The value must not exceed 0 knots. If the wind speed displayed exceeds 0 knots, contact ADB Safegate.

## 7.4 Troubleshooting

Symptom	Solution
No output	Check DC power to Model 2040, cable and connections. Check comms settings of Model 2040 (as detailed in Chapter 6) and host system match, including correct Com port Check unit is in Continuous mode Check that in line communication devices are wired correctly. NOTE: It is usual for TX + to be connected to converter device RX +
Corrupted output	Check comms settings of Model 2040 and host system match. Try a slower baud rate. Check cable lengths and type of cable.
One way communication	Check wiring is in accordance with the manual.
Failed / Incorrect Model 2040 output, data invalid flag	Check that transducer path is not blocked

## 7.5 Returning Unit

If the unit has to be returned, it should be carefully packed in the original packaging and returned to ADB Safegate with a full description of the fault condition.

## 7.6 Status (Error) Codes

The Status code is sent as part of each wind measurement message.

Code	Status	Condition
<b>00</b>	<b>OK</b>	<b>Sufficient samples in average period</b>
<b>60</b>	<b>OK and heating enabled</b>	<b>Sufficient samples in average period</b>
<b>A</b>	<b>OK</b>	<b>NMEA data valid</b>
01	Axis 1 failed	Insufficient samples in average period on U axis
02	Axis 2 failed	Insufficient samples in average period on V axis
04	Axis 1 and 2 failed	Insufficient samples in average period on both axes
08	NVM error	NVM checksum failed
09	ROM error	ROM checksum failed
10	System gain at max.	Inaccurate results likely
50	Marginal system gain	Results OK, but marginal operation
51	Measurement average building	
62	Heating current tripped or electronic failure	
63	Thermistor open circuit	
65	Heating element open circuit	
V	NMEA data invalid	

## 7.7 Bench Test

Couple the Model 2040 to the host system and power supply, using a known working test cable.

Check that the unit is correctly configured by going into Configuration mode and using **D3** See Section 6.3 Checking The Configuration.

Check for normal output data, and that the Status Code is OK – 00, 60 or A (for NMEA format).

If the status code is other than these, refer to Section 7.6 Status (Error) Codes.

Use an office fan or similar to check that the unit is sensing wind, turning the unit to simulate changing wind direction and to check that both axes are functioning.



### NOTE

This is a quick functional test. There are no calibration adjustments; the unit is designed NOT to require recalibration within its lifetime. ADB Safegate has provided and Integrity Check, see next page for details.

---

### 7.7.1 Zero Wind Chamber

The software to perform the Integrity Check (IC) is incorporated into the Model 2040 wind sensors.

The IC is designed to:

1. Identify any gross changes in the head geometry that would affect performance.
2. Provide a zero wind environment to confirm the Model 2040 zero wind speed calibration.

The Integrity Check is done indoors with an ambient temperature between 10°C and 28°C. When conducting the test, it is important that the Zero Wind Chamber is assembled on to the Model 2040 head and is neither touched nor moved during the test.

This test is only valid if undertaken with a Zero Wind Chamber purchased from ADB Safegate.

### 7.7.2 Integrity & Zero Wind Check

#### *Zero Wind Check*

Configure your PC to run HyperTerminal and assemble the Zero Wind Chamber by inserting the reflector cases and the two halves of the Zero Wind Chamber onto the Model 2040. The Zero Wind Chamber must be retained using the strips provided. Then:

1. Ensure that the Model 2040 wind sensor is set in factory default mode. For Factory default settings see Section 6.3.
2. Enter Measurement Mode and Record/View data

## Model 2040 Ultrasonic Wind Sensor

### *Integrity Check*

Ensure the Zero Wind Chamber is assembled correctly on the Model 2040. Using HyperTerminal, enter Configuration Mode as described in Section 6.1.

Enter D6.

A typical report as shown below will be displayed.

ALIGNMENT LIMITS: U=2417,2517

V=2369,2469

ALIGNMENT U:2467 \*PASS\*

ALIGNMENT V:2419 \*PASS\*

GAIN 0:0007 \*PASS\*

GAIN 1: 0007 \*PASS\*

GAIN 2:0008 \*PASS\*

GAIN 3:0008 \*PASS\* D6

If there has been no significant changes to the head configuration, then \*PASS\* will confirm correct operation.

Alterations to the head geometry will result in a \*FAIL\* message. If this occurs, please contact ADB Safegate.

## 8. Specifications

Parameter	Specification		
	Model 2040 Model 2040C	Model 2040H Model 2040HC	Model 2040HH Model 2040HHC
<b>Wind Speed</b>			
Range	0–65 m/s (0–145 mph)		0–70 m/s (0–156 mph)
Accuracy	±2% @ 12 m/s		
Resolution	0.01 m/s		
Offset	±0.01 m/s		
<b>Direction</b>			
Range	0 – 360°		
Accuracy	±2°		
Resolution	0.01°		
Offset	± 0.01 m/s		
Dead Band Wind Direction	None		
<b>Measurement</b>			
Output	1 Hz, 4 Hz, 10 Hz		1–4 Hz
Parameters	UV, Polar, NMEA, Tunnel		UV, Polar, NMEA
Units	m/s, knots, mph, km/h, ft/min		
Averaging	Flexible 1–3600 seconds		
<b>Serial Data</b>			
Serial Output	RS-422/RS-485, full duplex/half duplex		
Baud Rates	1200, 2400, 4800, 9600, 19200, 38400 bps		
Serial Port Parameter Setting	8 data bits, odd, even or no parity		
Sensor Status	Included as part of standard message		
<b>Optional Analog Outputs</b>			
	Speed, Direction, Status		
Scale	Multiples of ±10 m/s up to ±70 m/s		
Types	±2.5 V, 0–5 V or 4–20 mA		
V output Resistance	60 Ω		
4–20 mA Loading	10–300 Ω		

## Model 2040 Ultrasonic Wind Sensor

Parameter	Specification			
	Model 2040 Model 2040C	Model 2040H Model 2040HC	Model 2040HH Model 2040HHC	
<b>Power Requirements</b>				
Sensor Only	9–30 V DC (40 mA @ 12 V DC)		9–30 V DC (60 mA max, 50 mA average @ 12 V DC)	
Heating	—	3 A @ 24 V AC or DC	7 A @ 24 V AC or DC	
<b>Environmental</b>				
Operating Temperature	-55°C to +70°C			
Moisture Protection	IP66 (NEMA4X)			
Relative Humidity	0–100%, noncondensing			
Precipitation	300 mm/h			
Icing	MILSTD810F Method 521.1 Procedure 1			
<b>Mechanical</b>				
External Construction	316 Stainless Steel			
Dimensions	2040. 2040H, 2040HH	405 × 210 mm	405 × 210 mm	381 × 213 mm
	2040C. 2040HC, 2040HHC	477 × 213 mm		
Weight	2040. 2040H, 2040HH	1.5 kg (without cable)		1.4 kg (without cable)
	2040C. 2040HC, 2040HHC	2.4 kg		
Shipping Weight	2040. 2040H, 2040HH	3.3 kg (with cable)		5 kg (with cable)
	2040C. 2040HC, 2040HHC	3.2 kg (without cable)		
<b>EMC</b>				
EN 61326-1:2006, EN 55011:2007 (Traceable to NAMAS standards)				
<b>Site Calibration</b>				
None required. (See Section 7.7 Zero Wind Check)				

Model 2040 Ultrasonic Wind Sensor

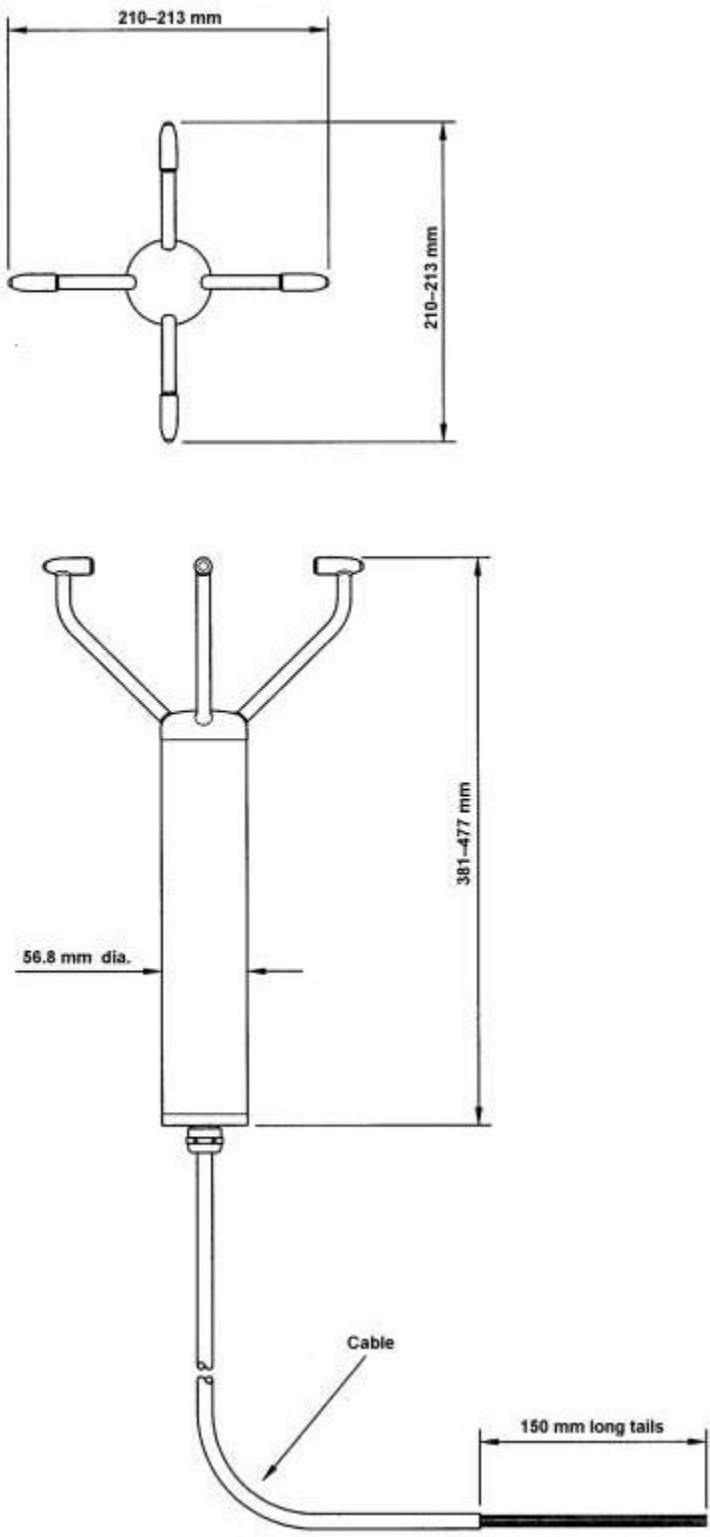

Figure 5. Model 2040 Ultrasonic Wind Sensor Outline Dimensions

## 9. Warranty



### NOTE

The warranty is void if the red security seal covering base nuts is damaged or broken, or the transducer caps have been damaged.

Unless specified otherwise, ADB Safegate. (the Company) warrants its products to be free from defects in material and workmanship under normal use and service for one year from date of installation or a maximum of two years from date of shipment, subject to the following conditions:

- a. The obligation of the Company under this warranty is limited to repairing or replacing items or parts which have been returned to the Company and which upon examination are disclosed, to the Company's satisfaction, to have been defective in material or workmanship at time of manufacture.
- b. The claimant shall pay the cost of shipping any part or instrument to the Company. If the Company determines the part to be defective in material or workmanship, the Company shall prepay the cost of shipping the repaired instrument to the claimant. Under no circumstances will the Company reimburse claimant for cost incurred in removing and/or reinstalling replacement parts.
- c. This warranty shall not apply to any Company products which have been subjected to misuse, negligence, or accident.
- d. This warranty and the Company's obligation thereunder is in lieu of all other warranties, express or implied, including warranties of merchantability and fitness for a particular purpose, consequential damages, and all other obligations or liabilities.

No other person or organization is authorized to give any other warranty or to assume any additional obligation on the Company's behalf, unless made in writing and signed by an authorized officer of the Company.

## Appendix A — Glossary & Abbreviations

Item	Meaning
CAL	Calibration
CR	Carriage Return
CR LF	Carriage Return Line Feed
CSV	Comma Separated Variable
ENG	Engineering
ESC	ESCape key on keyboard used to stop any process that is being executed
ETX	End of string character
FAC	Factory
ft/min	Feet per minute
GND	GrouND
HEX	HEXadecimal
I/P	InPut
IP66	Protection Classification
KPH	Kilometers per Hour
LF	Line Feed
m/s	Metres per second
MAG	MAGnitude scalar reference to wind speed
MAX	MAXimum
MPH	Miles per Hour
NEMA	National Electrical Manufacturers Association
NMEA 0183 (version 3)	National Marine Electronics Association standard for interfacing marine electronic navigational devices
No:	Number
NVM	Non-Volatile Memory
O/P	Output
PC	IBM compatible Personal Computer
PCB	Printed Circuit Board
POR	Power On Reset
PROCOMM	Terminal emulator software package
ROM	Read Only Memory

Model 2040 Ultrasonic Wind Sensor

Item	Meaning
RS-232	Communications standard
RS-422	Communications standard
RS-485	Communications standard
RTS	Request to Send
S/W	Software
SOS	Speed Of Sound
SEC	SECond
STX	Start of string character
TERM	TERMinal
TX	Transmit
TXD	Transmitted Data
+VE	Positive
-VE	Negative
WRT	With Respect To

## Appendix B — Principle Of Operation

The Model 2040 Ultrasonic Wind Sensor measures the times taken for an ultrasonic pulse of sound to travel from the North transducer to the South transducer, and compares it with the time for a pulse to travel from S to N transducer. Likewise times are compared between West and East, and E and W transducer.

If, for example, a North wind is blowing, then the time taken for the pulse to travel from N to S will be faster than from S to N, whereas the W to E, and E to W times will be the same. The wind speed and direction (and the speed of sound) can then be calculated from the differences in the times of flight on each axis. This calculation is independent of factors such as temperature.

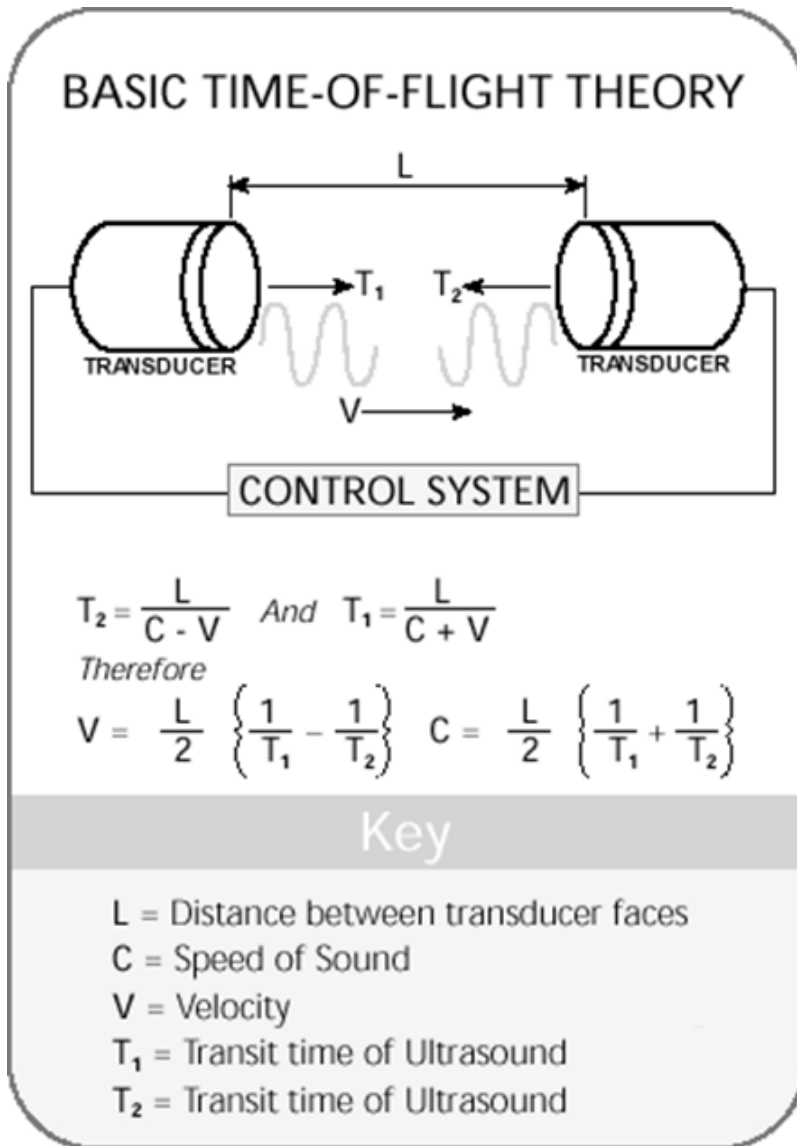

# Optimizing Airside Operations From approach to take-off

SMARTER. BETTER. **NOW.**

  
**ADB  
SAFEGATE**  
[www.adbsafegate.com](http://www.adbsafegate.com)