



L 852G(L) In-pavement Runway Guard Light (IRGL)

User Manual

96A0401, Rev. K, 2024/09/16



A.0 Disclaimer / Standard Warranty

CE certification

The equipment listed as CE certified means that the product complies with the essential requirements concerning safety and hygiene. The European directives that have been taken into consideration in the design are available on written request to ADB SAFEGATE.

ETL certification

The equipment listed as ETL certified means that the product complies with the essential requirements concerning safety and C22.2 No.180:13 (R2018) regulations. The CSA directives that have been taken into consideration in the design are available on written request to ADB SAFEGATE.

All Products Guarantee

ADB SAFEGATE will correct by repair or replacement per the applicable guarantee below, at its option, equipment or parts which fail because of mechanical, electrical or physical defects, provided that the goods have been properly handled and stored prior to installation, properly installed and properly operated after installation, and provided further that Buyer gives ADB SAFEGATE written notice of such defects after delivery of the goods to Buyer. Refer to the Safety section for more information on Material Handling Precautions and Storage precautions that must be followed.

ADB SAFEGATE reserves the right to examine goods upon which a claim is made. Said goods must be presented in the same condition as when the defect therein was discovered. ADB SAFEGATE further reserves the right to require the return of such goods to establish any claim.

ADB SAFEGATE's obligation under this guarantee is limited to making repair or replacement within a reasonable time after receipt of such written notice and does not include any other costs such as the cost of removal of defective part, installation of repaired product, labor or consequential damages of any kind, the exclusive remedy being to require such new parts to be furnished.

ADB SAFEGATE's liability under no circumstances will exceed the contract price of goods claimed to be defective. Any returns under this guarantee are to be on a transportation charges prepaid basis. For products not manufactured by, but sold by ADB SAFEGATE, warranty is limited to that extended by the original manufacturer. This is ADB SAFEGATE's sole guarantee and warranty with respect to the goods; there are no express warranties or warranties of fitness for any particular purpose or any implied warranties of fitness for any particular purpose or any implied warranties other than those made expressly herein. All such warranties being expressly disclaimed.

Standard Products Guarantee

Products manufactured by ADB SAFEGATE are guaranteed against mechanical, electrical, and physical defects (excluding lamps) which may occur during proper and normal use for a period of two years from the date of ex-works delivery, and are guaranteed to be merchantable and fit for the ordinary purposes for which such products are made.



Note

See your applicable sales agreement for a complete warranty description.

Replaced or repaired equipment under warranty falls into the warranty of the original delivery. No new warranty period is started for these replaced or repaired products.

FAA Certified products manufactured by ADB SAFEGATE

ADB SAFEGATE L858 Airfield Guidance Signs are warranted against mechanical and physical defects in design or manufacture for a period of 2 years from date of installation, per FAA AC 150/5345-44 (applicable edition).

ADB SAFEGATE LED products (with the exception of obstruction lighting) are warranted against electrical defects in design or manufacture of the LED or LED specific circuitry for a period of 4 years from date of installation, per FAA EB67 (applicable edition). These FAA certified constant current (series) powered LED products must be installed, interfaced and powered with and through products certified under the FAA Airfield Lighting Equipment Program (ALECP) to be included in this 4 (four) year warranty. This includes, but is not limited to, interface with products such as Base Cans, Isolation Transformers, Connectors, Wiring, and Constant Current Regulators.



Note

See your sales order contract for a complete warranty description.

Replaced or repaired equipment under warranty falls into the warranty of the original delivery. No new warranty period is started for these replaced or repaired products.

Liability



WARNING

Use of the equipment in ways other than described in the catalog leaflet and the manual may result in personal injury, death, or property and equipment damage. Use this equipment only as described in the manual.

ADB SAFEGATE cannot be held responsible for injuries or damages resulting from non-standard, unintended uses of its equipment. The equipment is designed and intended only for the purpose described in the manual. Uses not described in the manual are considered unintended uses and may result in serious personal injury, death or property damage.

Unintended uses, includes the following actions:

- Making changes to equipment that have not been recommended or described in this manual or using parts that are not genuine ADB SAFEGATE replacement parts or accessories.
- Failing to make sure that auxiliary equipment complies with approval agency requirements, local codes, and all applicable safety standards if not in contradiction with the general rules.
- Using materials or auxiliary equipment that are inappropriate or incompatible with your ADB SAFEGATE equipment.
- Allowing unskilled personnel to perform any task on or with the equipment.

Copyright Statement

This manual or parts thereof may not be reproduced, stored in a retrieval system, or transmitted, in any form or by any means, electronic, mechanical, photocopying, recording, nor otherwise, without the author's prior written consent.

This manual could contain technical inaccuracies or typographical errors. The author reserves the right to revise this manual from time to time in the contents thereof without obligation of the author to notify any person of such revision or change. Details and values given in this manual are average values and have been compiled with care. They are not binding, however, and the author disclaims any liability for damages or detriments suffered as a result of reliance on the information given herein or the use of products, processes or equipment to which this manual refers. No warranty is made that the use of the information or of the products, processes or equipment to which this manual refers will not infringe any third party's patents or rights. The information given does not release the buyer from making their own experiments and tests.

TABLE OF CONTENTS

1.0 Safety	1
1.1 Safety Messages	1
1.1.1 Introduction to Safety	2
1.1.2 Intended Use	2
1.1.3 Material Handling Precautions: Storage	3
1.1.4 Material Handling Precautions: Fasteners	3
1.1.5 Maintenance Safety	4
1.1.6 Material Handling Precautions, ESD	4
1.1.7 Arc Flash and Electric Shock Hazard	5
2.0 IRGL L-852G In-pavement light	7
2.1 Incandescent In-pavement Runway Guard Light	7
3.0 Installation	9
3.1 Typical L-868 Assembly	10
3.2 Safety Considerations	11
3.3 Photobiological safety	11
3.4 Verify Input Requirements and Equipment Needed	11
3.5 Unpacking the Unit	12
3.6 Inspect on delivery	12
3.7 Store	13
3.8 IRGL using a BRITE Remote, Installation	13
3.9 Earth Ground Connection	15
3.10 Installation on L-868 Base	15
3.11 Torquing and Installation Guidance for In-pavement Fixtures	16
3.12 Shallow base can installation	17
3.12.1 Installation on a Shallow Base	17
4.0 L852G IRGL Maintenance Schedule	19
4.1 Fixture Component Maintenance	19
4.2 Cleaning the Light Channel and Prism	19
4.3 Lifting Optical Unit Out of Base	19
4.4 Bolt Torque Preventive Maintenance Schedule	20
5.0 Troubleshooting and Maintenance	23
5.1 Troubleshooting	23
5.2 Repair Procedures	24
5.2.1 Opening Optical Unit	24
5.2.2 Replacing Prism	24
5.2.3 Replacing Optical Unit	26
5.2.4 Replacing L-823 Cordset	27
5.2.5 Replacing the PCB	28
5.2.6 IR Remote Control for autonomous L-852G	29
5.2.7 Remote RRHLG01 Programming Procedure	29
5.2.8 Testing for Leaks	30
6.0 IRGL Parts	33
A.0 SUPPORT	37
A.1 ADB SAFEGATE Website	38
A.2 Recycling	39
A.2.1 Local Authority Recycling	39
A.2.2 ADB SAFEGATE Recycling	39

1.0 Safety

Introduction to Safety

This section contains general safety instructions for installing and using ADB SAFEGATE equipment. Some safety instructions may not apply to the equipment in this manual. Task- and equipment-specific warnings are included in other sections of this manual where appropriate.

1.1 Safety Messages

HAZARD Icons used in the manual

For all HAZARD symbols in use, see the Safety section. All symbols must comply with ISO and ANSI standards.

Carefully read and observe all safety instructions in this manual, which alert you to safety hazards and conditions that may result in personal injury, death or property and equipment damage and are accompanied by the symbol shown below.



WARNING
Failure to observe a warning may result in personal injury, death or equipment damage.



DANGER - Risk of electrical shock or ARC FLASH
Disconnect equipment from line voltage. Failure to observe this warning may result in personal injury, death, or equipment damage. ARC Flash may cause blindness, severe burns or death.



WARNING - Wear personal protective equipment
Failure to observe may result in serious injury.



WARNING - Do not touch
Failure to observe this warning may result in personal injury, death, or equipment damage.



CAUTION
Failure to observe a caution may result in equipment damage.



ELECTROSTATIC SENSITIVE DEVICES
This equipment may contain electrostatic devices.

Qualified Personnel



Important Information

The term **qualified personnel** is defined here as individuals who thoroughly understand the equipment and its safe operation, maintenance and repair. Qualified personnel are physically capable of performing the required tasks, familiar with all relevant safety rules and regulations and have been trained to safely install, operate, maintain and repair the equipment. It is the responsibility of the company operating this equipment to ensure that its personnel meet these requirements.

Always use required personal protective equipment (PPE) and follow safe electrical work practice.

1.1.1 Introduction to Safety



CAUTION

Unsafe Equipment Use

This equipment may contain electrostatic devices, hazardous voltages and sharp edges on components

- Read installation instructions in their entirety before starting installation.
- Become familiar with the general safety instructions in this section of the manual before installing, operating, maintaining or repairing this equipment.
- Read and carefully follow the instructions throughout this manual for performing specific tasks and working with specific equipment.
- Make this manual available to personnel installing, operating, maintaining or repairing this equipment.
- Follow all applicable safety procedures required by your company, industry standards and government or other regulatory agencies.
- Install all electrical connections to local code.
- Use only electrical wire of sufficient gauge and insulation to handle the rated current demand. All wiring must meet local codes.
- Route electrical wiring along a protected path. Make sure they will not be damaged by moving equipment.
- Protect components from damage, wear, and harsh environment conditions.
- Allow ample room for maintenance, panel accessibility, and cover removal.
- Protect equipment with safety devices as specified by applicable safety regulations
- If safety devices must be removed for installation, install them immediately after the work is completed and check them for proper functioning prior to returning power to the circuit.

Failure to follow this instruction can result in serious injury or equipment damage

Additional Reference Materials



Important Information

- IEC - International Standards and Conformity Assessment for all electrical, electronic and related technologies.
- IEC 60364 - Electrical Installations in Buildings.
- CSA - C22.2 No.180:13 (R2018) Series isolating transformers for airport lighting
- FAA Advisory: AC 150/5340-26 (current edition), Maintenance of Airport Visual Aid Facilities.
- Maintenance personnel must refer to the maintenance procedure described in the ICAO Airport Services Manual, Part 9.
- ANSI/NFPA 79, Electrical Standards for Metalworking Machine Tools.
- National and local electrical codes and standards.

1.1.2 Intended Use



CAUTION

Use this equipment as intended by the manufacturer

This equipment is designed to perform a specific function, do not use this equipment for other purposes

- Using this equipment in ways other than described in this manual may result in personal injury, death or property and equipment damage. Use this equipment only as described in this manual.

Failure to follow this instruction can result in serious injury or equipment damage

1.1.3 Material Handling Precautions: Storage



CAUTION

Improper Storage

Store this equipment properly

- If equipment is to be stored prior to installation, it must be protected from the weather and kept free of condensation and dust.

Failure to follow this instruction can result in equipment damage

1.1.4 Material Handling Precautions: Fasteners



DANGER

Foreign Object Damage - FOD

This equipment may contain fasteners that may come loose - torque properly.

- Only use fasteners of the same type as the one originally supplied with the equipment.
- Use of incorrect combination of gaskets, bolts and nuts can create severe damages to the product installation and create safety risk .
- You need to know what base the light fixture will be installed in, in order to chose the correct gasket, bolts and nuts.
- Bolt type, length, and torque value are determined by type of base, height of spacers used, and clamp force required in FAA Engineering Brief No 83 (latest revision).
- Due to the risk of bolts vibrating loose, do not use any type of washer with the fixing bolts (such as split lock washers) other than an anti-vibration washer. Anti-vibration washers as defined in FAA EB 83 (latest edition) must be used. For installations other than FAA, use the base can manufacturer's recommendations.
- Always tighten the fasteners to the recommended torque. Use a calibrated torque wrench and apply the recommended adhesive type.
- Obey the instructions of the adhesives necessary for the fasteners.

Failure to follow these warnings may cause the fasteners to loosen, damage the equipment, potentially to loosen the equipment. This can lead to a highly dangerous situation of FOD, with potential lethal consequences.



Note

To minimize the risk of errors, the ADB SAFEGATE Sales Representative will have information on which gasket goes with which base. This information is also provided in the product Data sheets, the User Manuals and the Spare Part Lists.



CAUTION

Use of incorrect combination of gaskets, bolts and nuts can create severe damages to the product installation and create multiple safety risks.

To obtain a safe and watertight installation the O-ring and retaining bolt stated in the document must be used.

You need to know what base the light fixture will be installed in, in order to choose the correct gasket, bolts and nuts.

Failure to follow these cautions can result in equipment damage or aircraft FOD.

1.1.5 Maintenance Safety



DANGER

Electric Shock Hazard

This equipment may contain electrostatic devices

- Do not operate a system that contains malfunctioning components. If a component malfunctions, turn the system OFF immediately.
- Disconnect and lock out electrical power.
- Allow only qualified personnel to make repairs. Repair or replace the malfunctioning component according to instructions provided in its manual.

Failure to follow these instructions can result in death or equipment damage

1.1.6 Material Handling Precautions, ESD



CAUTION

Electrostatic Sensitive Devices

This equipment may contain electrostatic devices

- Protect from electrostatic discharge.
- Electronic modules and components should be touched only when this is unavoidable e.g. soldering, replacement.
- Before touching any component of the cabinet you shall bring your body to the same potential as the cabinet by touching a conductive earthed part of the cabinet.
- Electronic modules or components must not be brought in contact with highly insulating materials such as plastic sheets, synthetic fiber clothing. They must be laid down on conductive surfaces.
- The tip of the soldering iron must be grounded.
- Electronic modules and components must be stored and transported in conductive packing.

Failure to follow this instruction can result in equipment damage

1.1.7 Arc Flash and Electric Shock Hazard



DANGER

Series Circuits have Hazardous Voltages

This equipment produces high voltages to maintain the specified current - Do NOT Disconnect while energized.

- Allow only qualified personnel to perform maintenance, troubleshooting, and repair tasks.
- Only persons who are properly trained and familiar with ADB SAFEGATE equipment are permitted to service this equipment.
- An open airfield current circuit is capable of generating >5000 Vac and may appear OFF to a meter.
- Never unplug a device from a constant current circuit while it is operating; Arc flash may result.
- Disconnect and lock out electrical power.
- Always use safety devices when working on this equipment.
- Follow the recommended maintenance procedures in the product manuals.
- Do not service or adjust any equipment unless another person trained in first aid and CPR is present.
- Connect all disconnected equipment ground cables and wires after servicing equipment. Ground all conductive equipment.
- Use only approved ADB SAFEGATE replacement parts. Using unapproved parts or making unapproved modifications to equipment may void agency approvals and create safety hazards.
- Check the interlock systems periodically to ensure their effectiveness.
- Do not attempt to service electrical equipment if standing water is present. Use caution when servicing electrical equipment in a high-humidity environment.
- Use tools with insulated handles when working with airfield electrical equipment.

Failure to follow these instructions can result in death or equipment damage

2.0 IRGL L-852G In-pavement light

The IRGL can be used as in-pavement guard lights for runway incursion prevention applications. This low-energy long-life halogen lamp is rated with a life of 1,000 hours at 6.6A. An aluminum alloy is used as an inner and outer cover while using a light channel in front of prism windows to protect against rubber buildup.



2.1 Incandescent In-pavement Runway Guard Light

Compliance with Standards

FAA:	L-852G AC 150/5345-46 (Current Edition). Meets the requirements of Low-Visibility Taxiway Lighting Systems as specified by FAA AC 150/5340-30
-------------	---

Uses

- | | |
|-------------------|---|
| FAA L-852G | <ul style="list-style-type: none"> • Runway guard light • Runway incursion prevention |
|-------------------|---|

Features

- Designed and built with simplicity and ease of maintenance in mind
- Light channel in front of prism windows protects prisms from damage and prevents rubber buildup thereby maintaining optimal light output
- Low-energy/long-life halogen lamps are 105 W with a rated life of 1,000 hours at 6.6 A
- Low-temperature lights. Temperature rise at center of top cover remains below FAA-specified limit of 320 °F (160 °C).
- Fixture uses aluminum alloy cover and inner cover, stainless steel hardware, and aluminum alloy and stainless steel optical assembly
- Includes a UL 467 rated ground lug, which accepts an AWG 6 earth ground wire

3.0 Installation



WARNING

Read installation instructions in their entirety before starting installation.

- Become familiar with the general safety instructions in this section of the manual before installing, operating, maintaining or repairing this equipment.
- Read and carefully follow the instructions throughout this manual for performing specific tasks and working with specific equipment.
- Make this manual available to personnel installing, operating, maintaining or repairing this equipment.
- Follow all applicable safety procedures required by your company, industry standards and government or other regulatory agencies.
- Install all electrical connections to local code.
- Use only electrical wire of sufficient gauge and insulation to handle the rated current demand.
- All wiring must meet local codes.
- Protect components from damage, wear, and harsh environment conditions.
- Protect equipment with safety devices as specified by applicable safety regulations.
- If safety devices must be removed for installation, install them immediately after the work is completed and check them for proper functioning prior to returning power to the circuit.

Failure to follow these warnings may result in serious injury or equipment damage.

This section provides installation instructions for the L-852G, IRGL Light Fixture.

Input Requirement Summary

The F-Range light fixture is designed for connection to a 6.6 A or 20 A series lighting circuit via an L-830 (for 60Hz) or L-831 (for 50Hz) isolation transformer.

Unpacking

Each unit is individually packaged in a durable, cushioned, corrugated cardboard carton. To avoid unnecessary damage to the light assembly, unpack the carton at the installation site.

To unpack the carton, open the flaps and carefully remove the top packing material. Thread an eyebolt into each of the two opposite threaded holes. Run a rod through the eyebolts and lift the light assembly from the shipping carton. Set the light assembly in a protected area.

If damage to any equipment is noted, file a claim form with the carrier immediately. The carrier may request to inspect the equipment.

3.1 Typical L-868 Assembly

Figure 1: Diagram of the Fixture Installed in a 1-Piece Base Can

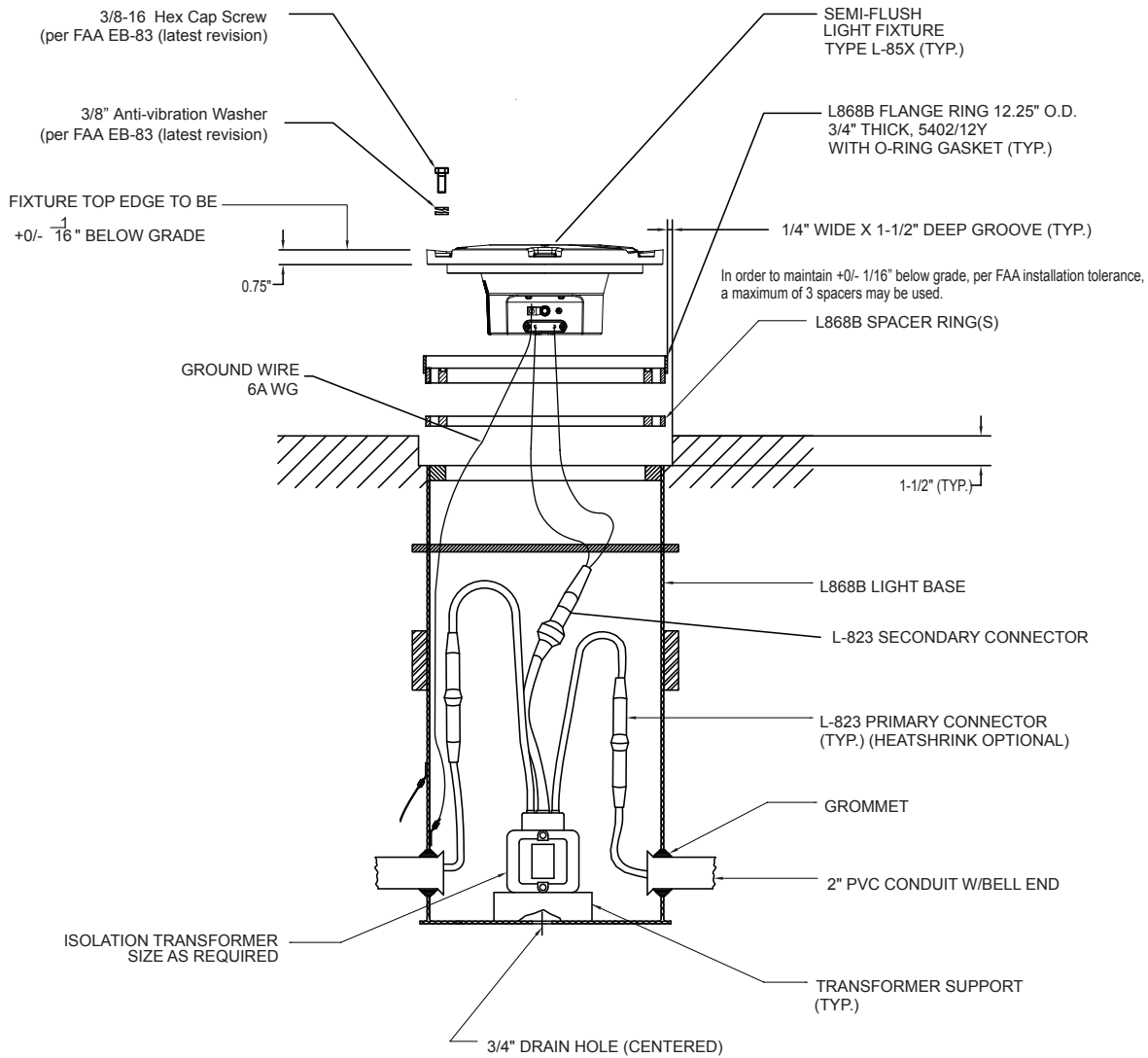

1. Torque according to: FAA EB-83 (latest revision).

Figure 2: Anti-vibration washer example

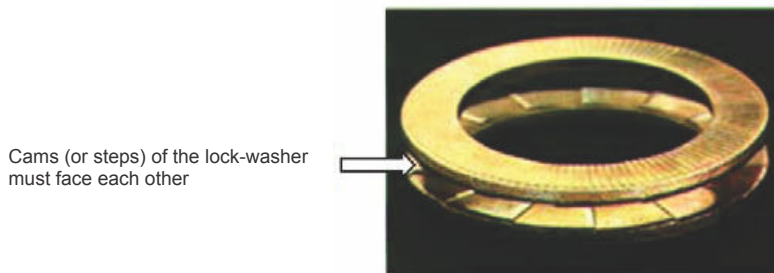



CAUTION

Per FAA AC 150/5340-30, Chapter 10, and FAA Engineering Brief No 83 (latest revision), it is extremely important that other types of washers, such as split washers, must not be used. Failure to use properly installed anti-vibration lock washers will cause mounting bolts to become loose. The cams (or steps) of each half of the lock washer must face each other.

3.2 Safety Considerations

Read the installation section of all system component manuals before starting these steps. A thorough understanding of system components and their requirements will promote safe and efficient installation. See FAA AC 150/5340-30, Design and Installation Details for Airport Visual Aids, and site plans and specifications for field installation of runway and taxiway in-pavement lights.



DANGER

Failure to follow these safety procedures can result in personal injury or death.

- Allow only qualified personnel to install ADB SAFEGATE and auxiliary equipment. Use only approved equipment. Using unapproved equipment in an approved system may void FAA approvals. Observe and follow the safety instructions in this document and all other related documentation.
- Make sure all equipment is rated and approved for the environment where it is being used.
- Follow all instructions for installing components and accessories.
- Install all electrical connections in compliance with local and national codes and regulations.
- Use only electrical wire of sufficient gauge and insulation to handle the rated current demand. All wiring must meet local and national codes.
- Route electrical wiring along a protected path. Make sure it will not be damaged by moving equipment.
- Protect components from damage, wear and harsh environmental conditions.
- Allow ample clearance for maintenance, panel accessibility and cover removal.
- Protect equipment with safety devices as specified by applicable safety regulations.
- If safety devices must be removed for installation, reinstall them immediately after the work is completed and check them for proper functioning.
- The cord set must be protected prior to installation.

3.3 Photobiological safety



CAUTION

Photobiological safety conforming with IEC 62471

RISK GROUP 0 or 1: Optical radiation emitted from LED lights may be harmful to the eyes. Do not stare with at the light source with bare eyes at a fixture operating at high intensity. Use protection goggles or similar protection method.

Goggles with a transmission factor not higher than 5% in the 400-530 nm band have been tested and provide adequate protection.

3.4 Verify Input Requirements and Equipment Needed

The In-pavement light fixture is designed for connection to a 6.6A or 20A series lighting circuit via an L-830 (60 Hz) or L-831 (50 Hz) isolation transformer.

Make sure you have the necessary tools and materials ready for installation (not supplied). Also consider other tools that might be needed based on site-specific conditions.

Table 1: Suggested Tools and Materials for Installation and Repair

Qty.	Description	Qty.	Description
1	Torque wrench	1	Set of screwdrivers, one with 3/8" (9.525mm) minimum blade width
1	Alignment jig		
1	Diamond-faced core drill	As needed	Silicone grease
1	Diamond-faced saw, 3/8" (9.525mm) thick	As needed	Joint sealing filler
1	Crimping tool	1	Pressure test fitting assembly
1	Small water suction pump	As needed	Dow Corning Molykote® 3452 or equal (P/N 67A0095) - used on top cover prism seal
2	Eyebolts, 3/8 inch (9.525mm) diameter		
1	Lifting rod, 16 inches (406mm) long	As needed	Novagard® Silicone Versilube® G322L™ (P/N 67A0009) - used on O-ring between top cover and inner pan assembly; also may be applied to four nipples of inner pan assembly to install optical assembly
1 or 2	L-830 / L-831 isolation transformer		
1	Set of fiber brushes		
1	Set of socket wrenches, 1/2" (12.7mm) drive		

3.5 Unpacking the Unit

To reduce the possibility of damaging the light assembly, unpack the light fixtures at the installation site. If damage to any equipment is noted, file a claim form with the carrier immediately.

When receiving the light fixture, open the box and verify that the characteristics of the light fixture correspond to the design requirements, such as type, color etc. When installing a light fixture where the control and monitoring function is to be activated at a later stage, make sure to register product information, such as PID/SN and position of the light fixture in, for example, a site documentation table. The information is required for remote activation and administration of control and monitoring functionality from a substation.

3.6 Inspect on delivery

1. Inspect all packings for visible damage.
2. Open every damaged box and inspect the contents for damage.
3. Immediately fill a claim form with the carrier if any fixture is damaged.
4. Store the fixture in its original packing in a protected area.



Note

If damage to any equipment is noted, file a claim form with the carrier immediately.



WARNING

Do not damage the cable insulation.



CAUTION

Do not unpack the fixture before it is at the installation site to avoid damage due to transportation and handling.

3.7 Store

Store the fixture in its original packing in a protected area. Indoor storage:

- Storage temperature: 14°F to 122°F (-10°C to +50°C).
- Humidity: <95% non condensing.

For long storage periods (longer than one year), we recommend to energize the LED lights once a year at nominal intensity (6.6 Amps) for 20 minutes.

3.8 IRGL using a BRITE Remote, Installation



Attention

- Read installation instructions in the entirety before starting installation.
- Do not unpack or remove the BRITE Remotes from their boxes until reading all these instructions.

See 96A0396 and 96A0397 for BRITE III/AGLAS remote/master

See 96A0199 and 96A0200 for BRITE I/BRITE II remote/master

Figure 3: Diagram of a BRITE Installation in a Series Circuit

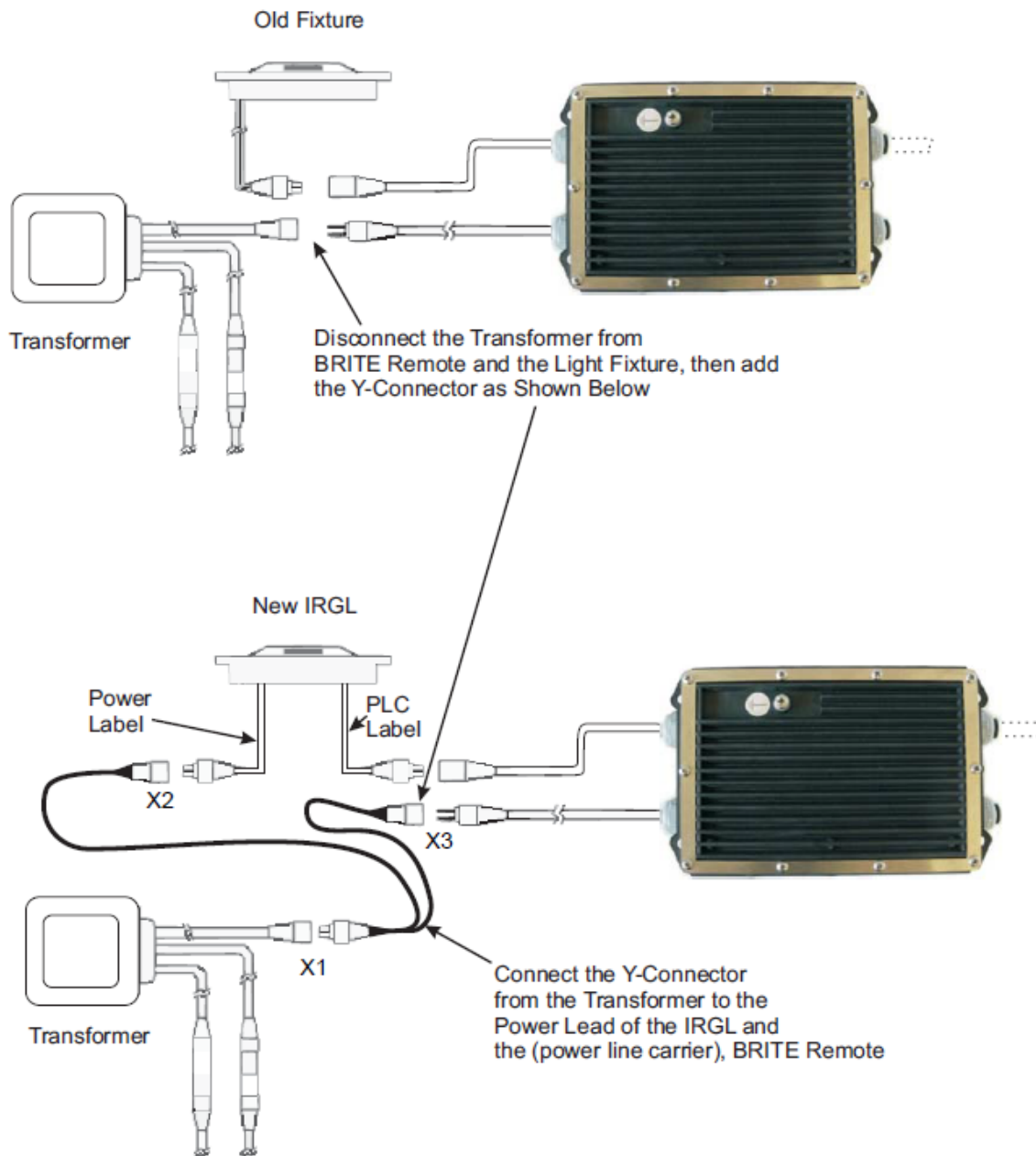

3.9 Earth Ground Connection

Figure 4: Base Can Cross-section

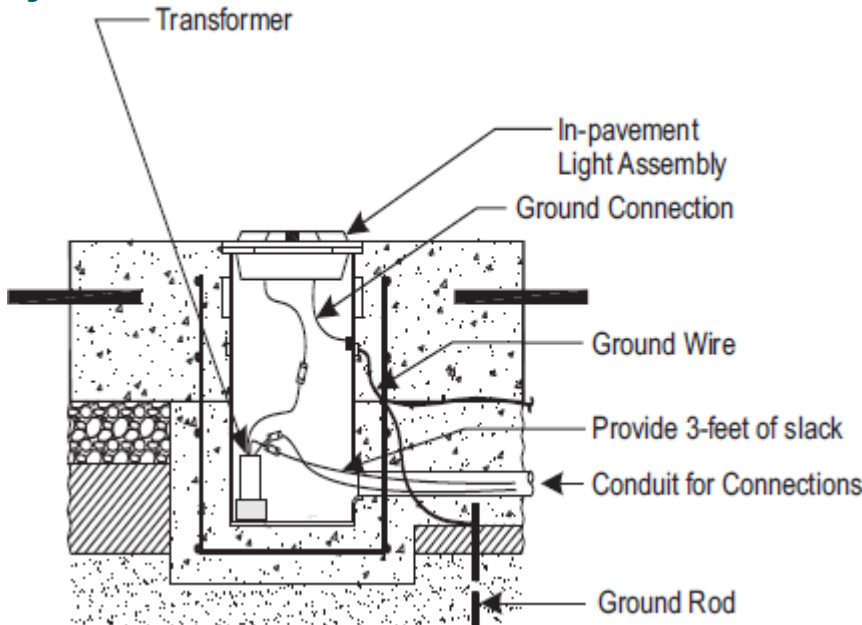

3.10 Installation on L-868 Base

The light assembly is shipped complete, and is ready for installation.

To install the fixture on an L-868 base, see FAA AC 150/5345-30 and the project site-specific plans and specifications for details on L-868 base installation.



Note

Mounting bolts are not supplied with the fixture. Mounting bolts and anti-rotation lock washers are normally supplied with the base can spacer or flange ring. If a flange ring is used, the bolt length is 1-1/4 inch (32mm) plus the thickness of the flange ring.

Also read the following guidelines:

1. Clean the base receptacle. Make sure the base receptacle is completely clean and dry. The mating surfaces must be clean and free of foreign particles.
2. If, present, fit an appropriate lifting tool into the two threaded holes, which are located 180° apart in the cover.



The lifting tool can be made from two 1/2 x 13 eyebolts (1-inch ID) and a 1/2-inch diameter, 16-inch (406mm) long rod or pipe inserted through the eyebolts.



CAUTION

Never hold the light fixture by the wires. Doing so may damage the insulation, break the waterproof seal and cause insulation faults and water leakage.

3. Carry the light assembly to the base.
 4. Place the light assembly next to the opening in the L-868 base so that the L-823 connector can be connected with the mating receptacle from the L-830 or L-831 isolation transformer in the base. Make sure that the connection is solid and secure. Refer to the Electrical Supply section of the User manual for required isolation transformers.
 5. Make sure items such as spacers, shims and gaskets are installed on the light base as indicated on site plans, specifications and drawings.
 6. Position the light assembly over the L-868 base and set it onto the base. Align the light according to FAA AC 150/5345-30 and project plans and specifications. Remove the eyebolts and lifting rod.
-



CAUTION

Ensure that the cord set wires are NOT pinched between the base can and the fixture. Pinched wires can cause water to be drawn inside the fixture.

7. If present, lubricate the labyrinth gasket with water. soap may be added to the water (8" only).
-



CAUTION

Do not use silicon or any other type of grease. Avoid the use of soap that contains silicon or glycerin.

8. Attach the six fixing bolts and anti-vibration washers. [See FAA EB-83 (latest revision)]
-



CAUTION

Due to the risk of bolts vibrating loose, do not use any type of washer with the fixing bolts (such as split lock washers) other than an anti-vibration washer. Anti-vibration washers as defined in FAA EB-83 (latest revision).

9. Turn on the power to determine whether the fixture will illuminate. Operate for a minimum of five minutes.

3.11 Torquing and Installation Guidance for In-pavement Fixtures

In-pavement fixtures must be installed according to the plans and specifications; the applicable regulatory guidance; and the following guidance. The importance of using the proper fixture clamping components and bolt torque to minimize the risk for fixture failure or loosening of clamping components cannot be overemphasized. Refer to FAA Engineering Brief No 83 (latest revision) for torque and installation guidelines for this fixture.

Also see our Product Center at www.adbsafegate.com.



CAUTION

Read installation instructions in their entirety before starting installation.

- Failure to follow the installation guidance could result in bolt loosening or bolts breaking off, resulting in catastrophic failure of the fixture and/or the mounting system components.
 - Failure to follow these warnings may result in serious injury or equipment damage.
-

3.12 Shallow base can installation

Shallow base cans may be non-load bearing or load bearing depending on location or fixture application. Following are specific requirements to insure that an either an elevated or an in-pavement fixture is properly installed.



CAUTION

Read installation instructions in their entirety before starting installation.

Fasteners:

- Make sure the power is OFF when you install or remove any fixture.
- Only use fasteners of the same type as the one originally supplied with the mounting support. See Base O-ring and Bolt Selection.
- Always tighten the fasteners to the recommended torque. Use a calibrated torque wrench and apply the recommended adhesive type.
- If this is not the case, this may cause the fasteners to loosen, damage the fixture, potentially to loosen the fixture. This can lead to a highly dangerous situation of FOD, with potential lethal consequences.
- Obey the instructions of the adhesives necessary for the fasteners.
- Only install the fixture on mounting supports:
 - That ADB Safegate has approved;
 - That are installed according to the Instruction Manual of the mounting support.
- Failure to do so can result in a highly dangerous situation of FOD, with potential lethal consequences.

Failure to follow these warnings may result in serious injury or equipment damage.



CAUTION

Proper Operation:

- The fixture is supplied from a 6.6 A series circuit;
- The series circuit is powered by a Constant Current Regulator that complies with IEC 61822;
- The transformer is an AGL series transformer that complies with IEC 61823.
- The power of the series transformer shall not exceed 200 W, for versions with the monitoring option.
- The mounting support is correctly earthed. Failure to do so will void the warranty for all damages that occur as a result of voltage surges.
- Never hold the fixture by the cable leads. This can damage the insulation, break the waterproof seal and cause insulation faults and water leakage.



Note

See the Instruction Manual of the mounting support for instructions on how to earth the mounting support.

3.12.1 Installation on a Shallow Base

Installing the light fixture on a shallow base involves preparing the pavement recess and wireways, then installing the light fixture on a shallow base.

See FAA AC 150/5345-30 and the project site-specific plans and specifications for details on shallow base installation.

Also follow the applicable instructions in the previous section, when connecting, installing and powering the fixture.

Figure 5: Example of a Shallow Base Installation

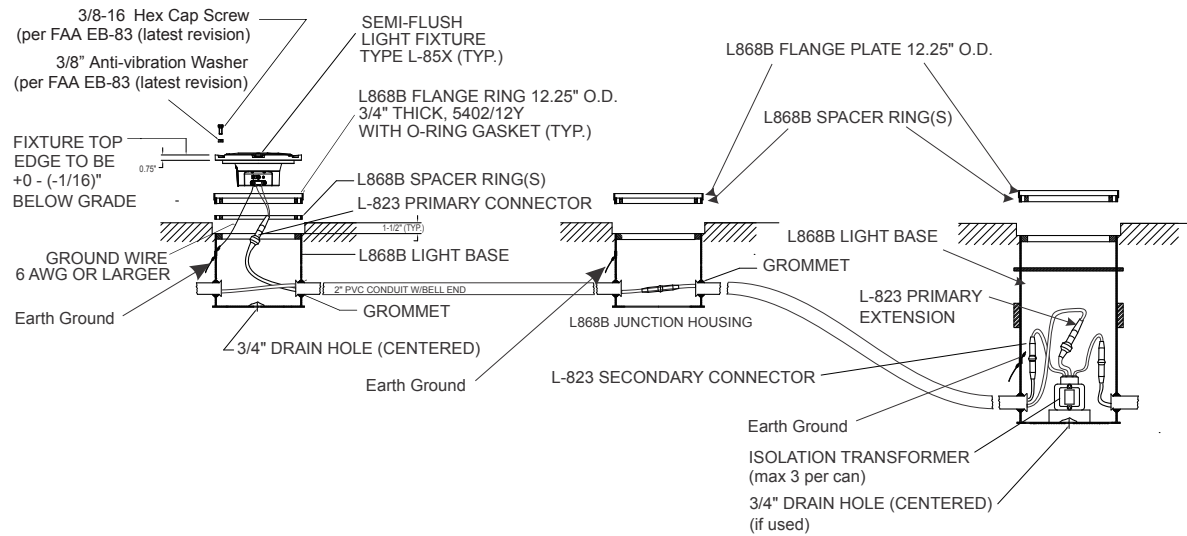

1. Torque according to: FAA EB-83 (latest revision).

Figure 6: Anti-vibration washer example

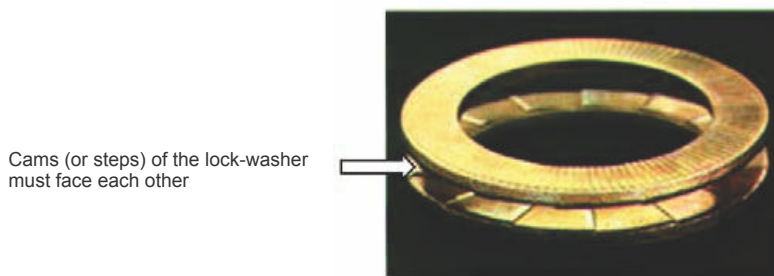

CAUTION

Per FAA AC 150/5340-30, Chapter 10, and FAA Engineering Brief No 83 (latest revision), it is extremely important that other types of washers, such as split washers, must not be used. Failure to use properly installed anti-vibration lock washers will cause mounting bolts to become loose. The cams (or steps) of each half of the lock washer must face each other.

4.0 L852G IRGL Maintenance Schedule

Interval	Maintenance Task	Action	Refer to:
Weekly	Check for dirty channel and prism.	Clean channel and prism.	Cleaning the Light Channel and Prism
Monthly (more often during rainy seasons)	Check for moisture in the light fixture.	Open up the light fixture. Clean, dry, and inspect the light assembly. Replace O-ring.	—
Every 60 days (also whenever the light assembly is serviced)	Check for improper torque on hold-down bolts.	Torque the six bolts holding the fixture to the base.	Installation on L-868 Base
After snow removal	Check for damaged light fixtures.	Replace damaged fixtures. Use a power broom for snow removal, if practical.	

4.1 Fixture Component Maintenance



WARNING

Turn off the circuit before replacing fixture(s). Failure to observe this warning may result in personal injury, death, or equipment damage.

The preferred method of maintaining the F-Range inset light is to periodically and systematically replace the light assembly and return the replaced assembly to the maintenance shop for renovation. As an alternative, you can service the light assembly in the field. It is recommended, however, that field servicing be limited to cleaning lenses and removing moisture.

4.2 Cleaning the Light Channel and Prism

To clean the light channel and prism, perform the following procedure:

1. Use a suitable fiber brush to remove all accumulated debris from the light channel (4).
2. Clean the outer surface of the prism (3) using liquid glass cleaner. If the prism is coated with a substance impervious to the cleaner, apply a suitable solvent sparingly with a wad of cotton or a patch of cloth. After the solvent has acted, remove the softened coating with a clean piece of cotton or cloth. Dry the prism with gently, dry, oil-free compressed air at a pressure no greater than 10 psi (69 KN/m²) to evaporate or remove all remaining cleaner.

4.3 Lifting Optical Unit Out of Base

To lift the optical unit from the light base, perform the following procedure:

1. Remove the six fixing screws and washers or self locking nuts.
2. Fit the appropriate lifting tool into both threaded holes located (180 degrees apart) in the cover, lift the optical unit out of the base and place the optical unit next to the base.
3. Disconnect the light fixture wires from the power wires coming from the transformer(s).
4. Mount a serviced or new light fixture as described in Installation on L-868 Base in the Installation section.



Note

See “Bolt Torque Preventive Maintenance Schedule”.

5. Take the inset fixture unit back to the maintenance base where it can be serviced entirely.



Note

Never hold the light fixture by the wires. This may damage the insulation, break the waterproof seal, and cause insulation faults and water leakage.

4.4 Bolt Torque Preventive Maintenance Schedule

An established schedule for checking light fixture bolt torque and bolt condition is mandatory. This is particularly true for areas that are subject to high impact loads from aircraft such as runway status lights, runway touchdown zone lights, runway centerline lights, and taxiway lead-off lights. Although AC 150/5340-26 offers a recommended schedule for periodic checks, these checks should be tailored to the facility based on local conditions such as environmental issues and runway traffic load.

1. Torque according to: FAA Engineering Brief No 83 (latest revision).

Figure 7: Anti-vibration washer example

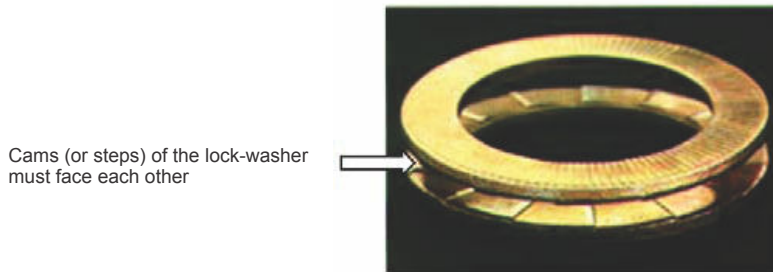

CAUTION

Per FAA AC 150/5340-30, Chapter 10, and FAA Engineering Brief No 83 (latest revision), it is extremely important that other types of washers, such as split washers, must not be used. Failure to use properly installed anti-vibration lock washers will cause mounting bolts to become loose. The cams (or steps) of each half of the lock washer must face each other.

FAA Cert Alert No. 14-03 refers to AC 150/5340-26 for the frequency of checking bolt torque. AC 150/5340-26 (latest revision) paragraph 5.3.4.1.4, *Bi-Monthly Checks* states: "The torque of the bolts attaching the light fixture to its base should be checked with a calibrated torque wrench – never use an impact wrench."

Regular inspection as outlined in FAA Engineering Brief 83 (latest edition), Canada Civil Aviation Safety Alert Document CASA 2014-05, and any other applicable regulatory guidelines is critical in insuring torque on all bolts is restored to optimum values. Bolts that loosen more often should be inspected and re-torqued on a more frequent basis.

It is especially important to maintain a regular inspection schedule for LED fixtures. Since LED fixtures operate more reliably and are not subject to removal/replacement/re-torque as frequently as would be seen with incandescent fixtures, it is even more important to implement regular torque inspections.

It is critical that remedial action be taken if bolts are found to be loose or missing during inspection. If this occurs, it is important to carefully inspect all structural elements of the mounting system as defined in Installation. Also inspect the base can for general structural conditions such as:

- Is the base can solidly mounted in the pavement, and not moving or rocking during rollovers?
- If a base can extension is present, are all extension attachment bolts tight?

If poor base can structure or mounting system components are not in accordance with regulatory requirements or are in poor condition, it is the airport's responsibility to:

- Increase the frequency of bolt torque inspection to insure that no bolts become loose or missing.
- Quickly replace/repair the mounting system components, which may include replacing the entire base can.

Airport operators must also ensure these maintenance activities are properly documented.

Digital Asset Tracking and Service Application Information

ALIS is ADB SAFEGATE's new digital asset tracking, inspection and service solution, helps airports easily register airside assets, electronically schedule and track maintenance, and record maintenance and inspection tasks in compliance with ICAO and FAA standards.

Easy to implement and use, cloud-based software enables a more reliable and fail-safe approach to asset tracking and maintenance by always using live field data and eliminating inefficiencies caused by human error. Every asset is registered using GPS data and its status recorded, so airport maintenance teams get a clearer view of maintenance schedules and history, allowing them to manage resources more effectively as well as improve the safety and longevity of airside assets. This increased visibility helps airports plan and schedule preventive maintenance, or undertake corrective maintenance more quickly, to reduce downtime and significantly improve operational availability.

<https://adbsafegate.com/product-center/airfield/airside-services/ALIS-airside-maintenance>

- Easily integrates electronic torque measurements and photometric measurement reports to provide a complete view of the asset's status.
- ALIS can be integrated with the AirTorque or Ingersoll Rand® QX series wrenches, which are used for accurate, ergonomic torque inspections of AGL fixtures. The applied torque can seamlessly be registered in the ALIS system as a part of the maintenance record.
- The iPhone application of ALIS – ALIS Personal – makes it easier than ever to register maintenance actions while working. It will proactively show you which assets you still need to work on and select the closest one to you automatically. ALIS Personal acts as a feedback and information device for the associated torque wrench.

5.0 Troubleshooting and Maintenance



WARNING

Read installation instructions in their entirety before starting troubleshooting or maintenance

- Become familiar with the general safety instructions in this section of the manual before installing, operating, maintaining or repairing this equipment.
- Read and carefully follow the instructions throughout this manual for performing specific tasks and working with specific equipment.
- Make this manual available to personnel installing, operating, maintaining or repairing this equipment.
- Follow all applicable safety procedures required by your company, industry standards and government or other regulatory agencies.
- Install all electrical connections to local code.
- Use only electrical wire of sufficient gauge and insulation to handle the rated current demand. All wiring must meet local codes.
- Protect components from damage, wear, and harsh environment conditions.
- Protect equipment with safety devices as specified by applicable safety regulations.
- If safety devices must be removed for installation, install them immediately after the work is completed and check them for proper functioning prior to returning power to the circuit.

Failure to follow these warnings may result in serious injury or equipment damage.

5.1 Troubleshooting

Problem	Possible Cause	Corrective Action
Lamp not pulsing	Defective remote control device	Consult the remote control device's instruction manual.
Short lamp life	Current too high (series circuit applications)	Check constant current regulator output current levels. Check the label on the isolation transformer and replace if necessary. For example, incorrectly installing a 6.6A/20A transformer will cause very fixture component life.
	Water in assembly	Inspect the prism. Open light assembly. Clean, dry and inspect light assembly. Replace O-ring. Verify fixture is sealed. See Cleaning the Light Channel and Prism
Distorted light beam output	Broken, damaged or wrong prism installed	Check parts list and install correct prism
	Damaged or missing prism seals or top cover O-ring	Replace both prism seals. Replace top cover O-ring. Verify that the fixture is sealed.
Water inside optical chamber	Fixture wires pinched between base can and fixture	A break in the fixture wire insulation will cause water to be drawn into the fixture during the fixture's heating and cooling cycle (when switched on and off). Replace fixture leads. Use care when remounting the fixture on the base can to ensure that the wires do not get pinched.



Note

Once power from the CCR is turned off for 3-seconds and then on again, the BRITE system will re-establish timing with all Remotes and reset any Remotes with replaced components.

5.2 Repair Procedures

5.2.1 Opening Optical Unit

To open the optical unit, perform the following procedure:

1. Turn the light unit upside-down.
2. See [Figure 8](#) . Remove the pressure release screw (E11).



Note

Removing the pressure release screw equalizes the pressure inside and outside the fixture, making it easier to break the seal and remove the inner cover.

Figure 8: Pressure Release Screw

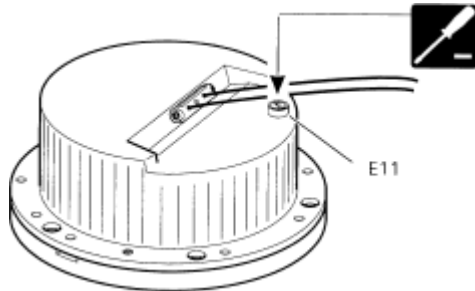

3. See [Figure 9](#) . Remove the ten screws (E10). The use of an impact driver may be required to unlock the screws.

Figure 9: Removing Screws

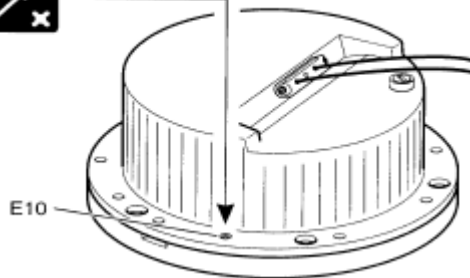

4. See [Figure 10](#) . Insert small or medium flat blade screwdriver in the machined recess slot between cover and inner cover and turn it vertically to separate the inner cover from the cover.

Figure 10: Separating Inner Cover from Top Cover

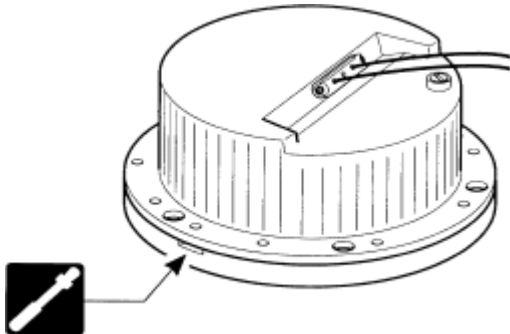

5.2.2 Replacing Prism

Replace the prism if it is broken or its surface is badly pitted or scarred.

Refer to [Table 2](#) for parts referred to in [Figure 11](#) through [Figure 12](#) .

Table 2: Parts List for Replacing Prism

Part Number	Description	Quantity	Note
63A0993/2	Prism, narrow beam, optical glass	3	

To replace the prism, perform the following procedure:

1. See [Figure 11](#) .

Remove the prism-clamp and prism-keeper plate secured in the inner pan assembly.

Figure 11: Replacing Prism

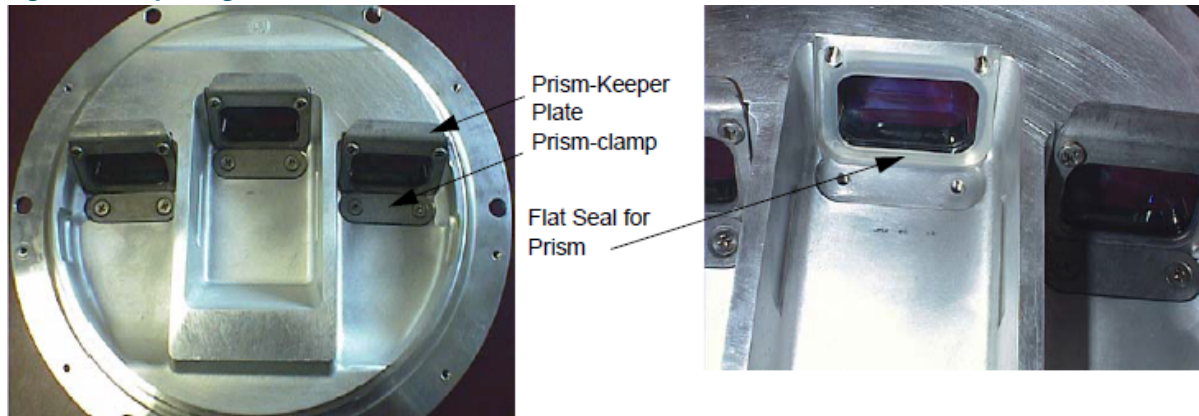
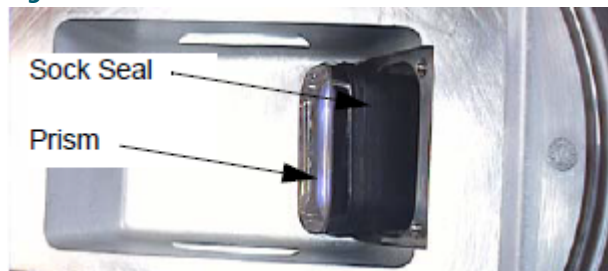

Figure 12: Sock Seal for Prism



2. See [Figure](#) . Remove the flat seal.
3. See [Figure 12](#) . Push the prism with the sock seal towards the inside of the cover.
4. Clean and remove grease from the prism chamber with any effective solvent.



Note

Never use any abrasive substance. This will scratch or frost the prism.

5. Apply a thin layer of Dow Corning Molykote 3452 or equivalent in the prism chamber using a small brush.
6. Install a new sock seal over the prism.
7. Push the prism/gasket assembly in the prism pocket from the inside and clean the inner surface of the prism.
8. Install a new flat seal over the prism-keeper plate.
9. See [Figure 11](#) . Reinstall hardware with the Phillips pan head screws. Apply a droplet of sealant Loctite 270 to the last threads. Torque to 31 ± 4 inch-pounds (3.5 ± 0.5 N•m).

5.2.3 Replacing Optical Unit

Table 3: Parts List for Replacing Optical Unit

Item	Part Number	Description	Quantity	Note
1	48A0415-TYLW	LED Light Engine	3	

Figure 13: IRGL LED Assy

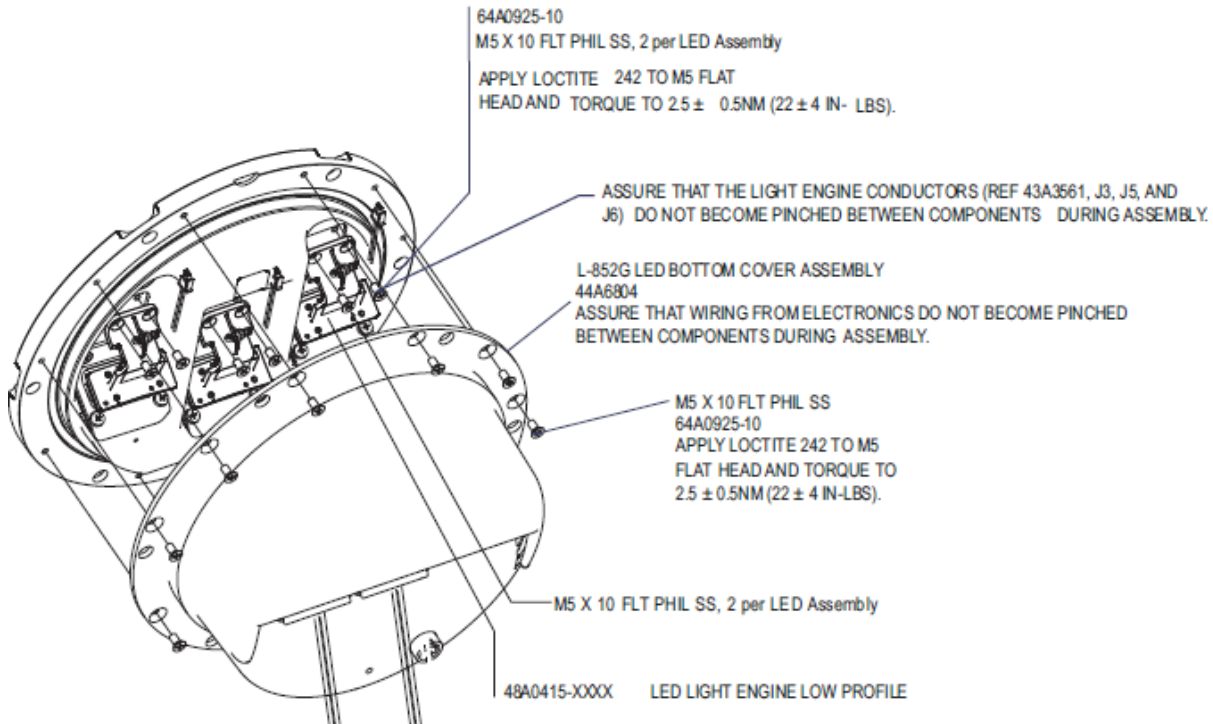

1. Open the Optical Unit, see [Opening Optical Unit](#).
2. Disconnect the LED Assembly wires at the PCB by pressing on the Molex Connectore clip and pulling gently upward.
3. Remove the two Phillips Head screws, clean the mounting surface of the top cover.
4. Replace the LED Assembly, attach with two Phillips Head screws, apply a drop of Loctite 242 and torque to $2.5 \pm 0.5\text{N}\cdot\text{m}$ (22 ± 4 IN-LBS).
5. Connect the LED Assembly to the PCB.
6. Close the Optical Unit.
7. Test for leaks, see ["Testing for Leaks"](#).

Figure 14: LED Light Engine Connections

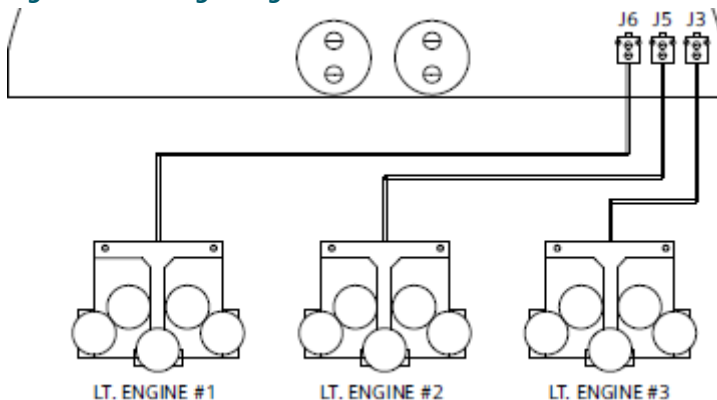

5.2.4 Replacing L-823 Cordset

Refer to [Table 4](#) for parts referred to in [Figure 15](#) thru [Figure 18](#).

Table 4: Parts List for Replacing L-823 Cordset

Item	Part Number	Description	Quantity	Note
	62A2145-3	Top cover	1	
Item F5 on Figure 15	63A1014	Grommets (for cordset)	2	
Item F6 on Figure 15	4071.50.090	Wire clamp (for cordset)	1	
Item F7 on Figure 15	7110.08.367	Screw, M4 x 10 (for cordset)	2	
Item F8 on Figure 15	73A0133-31	Cordset	1	
	6111.87.140	Fast-on connector	2	

To replace the L-823 cordset, perform the following procedure:

1. Open the optical unit. Refer to [Opening Optical Unit](#).
2. Disconnect the LED Assemblies from the PCB.
3. Remove the PCB.
4. See [Figure 15](#). Remove both screws (F7) and the wire clamp (F6).



Note

Replace the wire grommets (F5) when damaged or aged.

5. Unplug the fast-on connectors from the cable assembly wiring.

Figure 15: L-823 Cordset

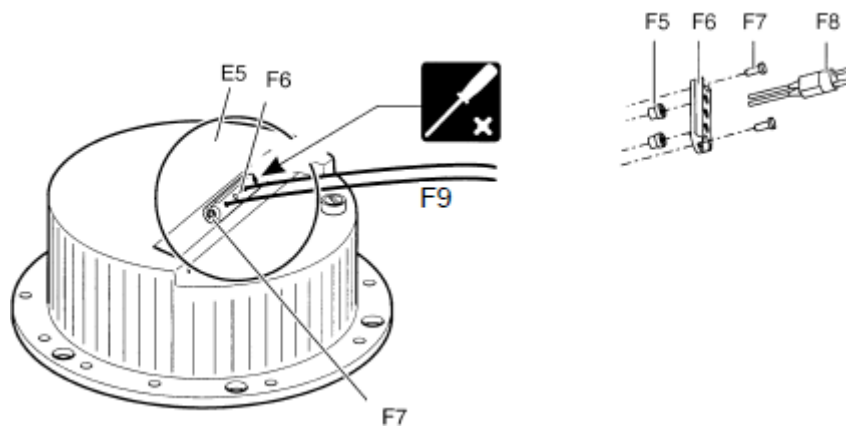

6. Pull the cordset out of the unit.
7. Replace the cordset by slipping the cords through the wire clamp (F6) wire grommets (F5) and the optical base.
8. Replace the PCB.
9. Attach the fast-on connectors to the PCB.
10. Close the optical unit.
11. Test for leaks, see ["Testing for Leaks"](#).

5.2.5 Replacing the PCB

Figure 16: IRGL PCB

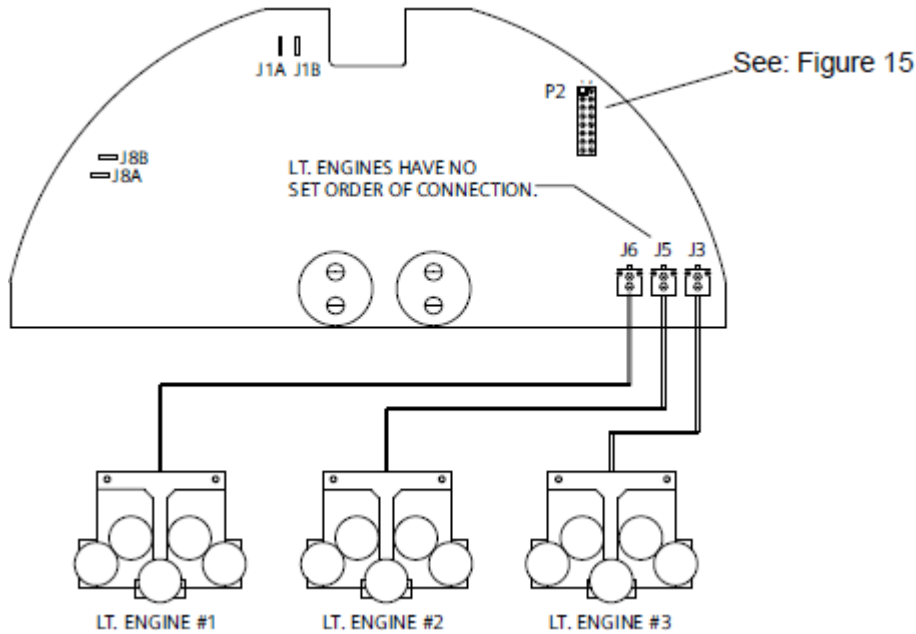

1. Open the optical unit. Refer to [Opening Optical Unit](#) .
2. Disconnect the LED Assemblies from the PCB and disconnect the fast-on connectors J1A and J1B.
3. Remove the PCB.
4. Check the shunt positions and set the new PCB to the same settings. See [Figure 18](#).

Figure 17: L-852G LED, Cordset and Light Engine Wiring Diagram

NOTE: Autonomous lights do not use a BRITE Remote and therefore do not have the Power Line Carrier (PLC) lead.

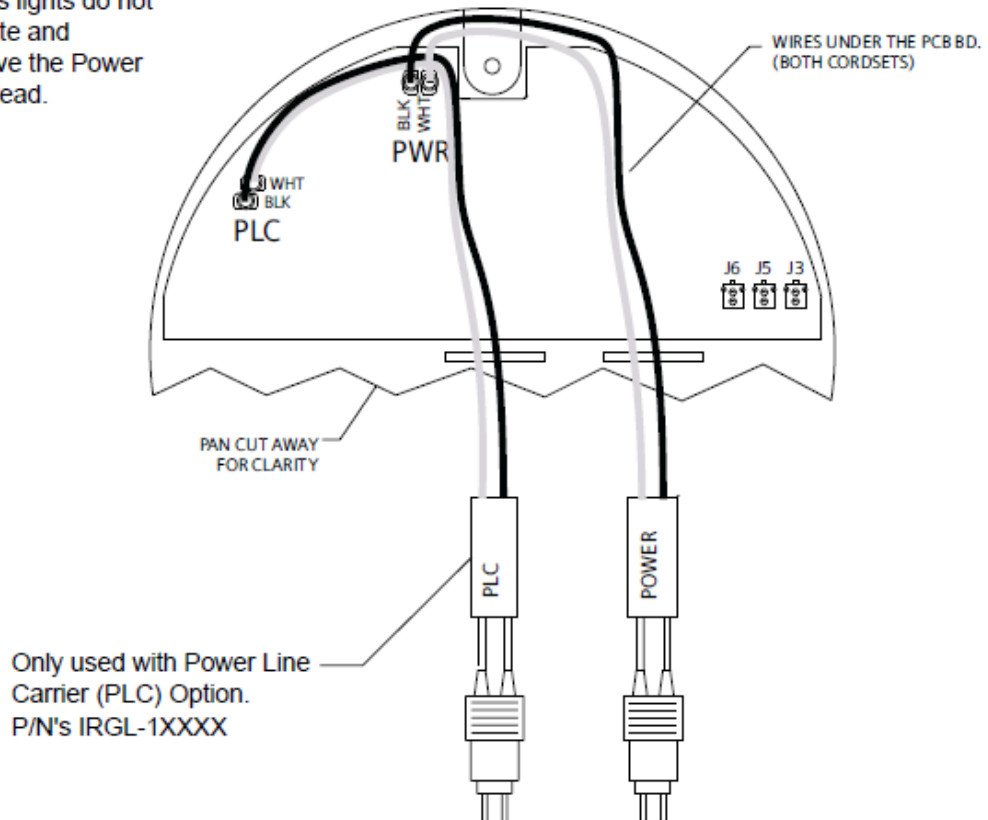

5. Replace the PCB and reconnect all wires.
6. Close the unit and, test for leaks, see ["Testing for Leaks"](#).

5.2.6 IR Remote Control for autonomous L-852G

For Autonomous, Unmonitored Applications

- Part Number: 61A0458
- Only one Remote Control is needed per installation.

Figure 18: PCB P2 Shunt Positions

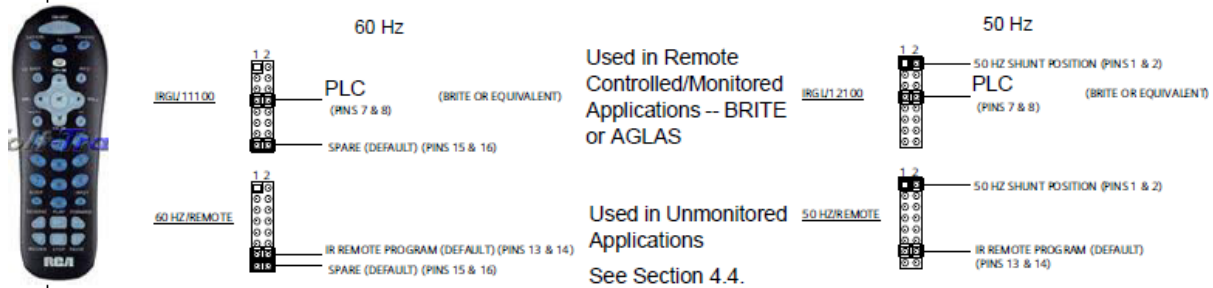

5.2.7 Remote RRHLG01 Programming Procedure

IR Remote Configuration procedure if the remote stops working or Anderic RRHLG01 batteries are replaced.



1. Press and hold the component key **TV (top-left)** for 3 seconds until the TV key light remains on. Release the TV key. The illuminated ON/OFF key turns on and remains on. During the programming mode, not pressing any button for 20 seconds will cause the remote to exit the programming mode.
2. Use the number keys (0-9) on the keypad to enter 2001. (old remote=1172)
 - a. If valid - the Mode key light will go out directly.
 - b. If invalid - the Mode key will blink 3 times quickly and go out. Please return to step 1.
3. Turn on the the IRGL-STB light you wish to control.
4. Check if the keys can control the IRGL light. (place the remote close and right in front of the light channel)
 - a. Ensure "TV" mode is enabled (press and release "TV" button).
 - b. Press and release "0" button (for initial flash "ON").

- c. Press and release "cc" button. (old remote was "OK" button)
- d. Verify the fixture flashes 4 times. (unit is configured for initial flash "ON".)

L-852G/S Programming



Note

The IR Remote is only used in unmonitored applications in which no Remote Control device is present. Prior to using the IR Remote, the fixture must be energized at any brightness step and flashing.

- 5. Press and release the remote **TV** key.
- 6. Point the IR Remote at the L-852G/S right light channel.
 The IR Remote should be held approximately 0.5" (13 mm) from the right light channel at an angle of approximately 45° from the pavement surface.
- 7. Press and release IR Remote keys according to the following table.

Setting	First Key	Second Key	NOTES
Initial Flash ON	0	"CC" (old remote was "OK" button)	The IRGL light turns on, then turns off.
Initial Flash OFF	2	"CC" (old remote was "OK" button)	The IRGL light turns off, then turns on.
ON alternative	1	"CC" (old remote was "OK" button)	Note If a CCR only powers a single RGL bar, the L-852G fixtures within the bar shall be configured "ON (IRGL/2X100 Initial flash ON) next OFF (IRGL/3X100 Initial flash OFF) next ON (IRGL/2X100 Initial flash ON) ... etc." If a CCR powers multiple RGL bars, it is recommended that approximately half of the continuous bars shall be configured "ON next OFF" and the rest use the "alternative ON next alternative OFF" settings. The alternative settings incorporate a small time delay (when compared to the ON or OFF setting). This small time delay on half of the RGL bars evens out the load on a CCR, reducing CCR output current fluctuations.
OFF alternative	3	"CC" (old remote was "OK" button)	

- 8. The First Key is pressed followed by the "CC" key within 2 seconds. (old remote was "OK" button)



Note

The system will respond to an INQUIRY to the programmed setting as follows:

- a. programmed for '0', unit will flash 4 times to confirm setting.
 - b. programmed for '2', unit will flash 2 times to confirm setting.
- 9. The L-852G should start to flash as commanded. The setting is kept in its volatile memory.



Note

The programming procedure can be repeated if necessary.

5.2.8 Testing for Leaks

To test for leaks, perform the following procedure:

- 1. See [Figure 19](#).

Remove pressure relief screw.

2. See [Figure 20](#).

Screw pressure test fitting into the pressure relief port (the opening created when the pressure relief screw is removed).
Screw fitting hand-tight.

Figure 19: Pressure Relief Screw



Figure 20: Pressure Test Fitting Assembly

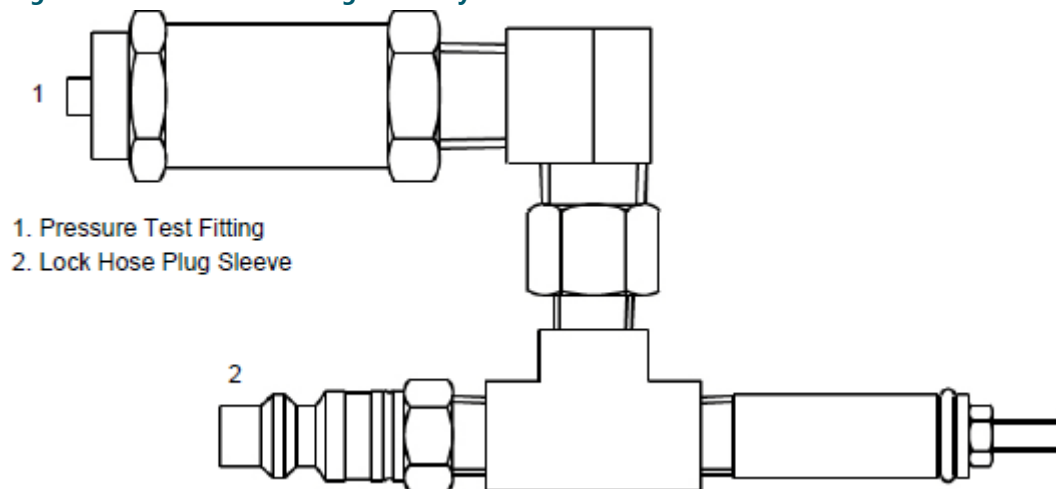

1. Pressure Test Fitting
2. Lock Hose Plug Sleeve

3. Attach the shop airline to the lock hose plug sleeve (2).

4. Pressurize to 20 psi.

5. Submerge the pressure test fitting in a water tank.

Check for air bubbles. Air bubbles indicate a leak.

6. Locate the leak source, depressurize, replace the seal that is leaking, reassemble, and retest by following steps 4 and 5.

If leak is fixed, depressurize and reinstall the pressure release screw (1).

Go to [Installation](#) to finish.

6.0 IRGL Parts

Ordering Code

44A5875 - 2 X 1

Base Mounting

1 = L-823 cord set for standard base

Lamp

1 = 105 W, 6.6 A



Note

Runway Guard Lights should be powered with ferroresonant type CCRs. RGLs using incandescent lamps should not be powered with thyristor type CCRs.

Table 5: Spare Parts

Description	Part No.
Ground lug kit	94A0469-2
IR Remote Control for autonomous L-852G	61A0458
Y-harness Adapter	70A0761
Cord set terminal, female	6111.87.140
Dow Corning Molykote 3452 or equivalent	As needed
Cable Clamp	4071.50.090
Cord Set L-823	73A0133-31
Cord Set Grommet	63A1014
LED light engine, L-852G, Style 3, yellow	48A0415-TYLV
O-ring, inner cover seal	MS00001-376-01
O-ring, pressure release screw	63B0267-011
Pressure release screw	60A2602
Prism	63A0993-2
Prism clamp	4071.50.360
Prism gasket sleeve	4071.50.030
Prism keeper plate	4071.50.052
Prism keeper plate seal	63A0986
LED L-852G power supply mounting assembly	44A6823/1

Figure 21:

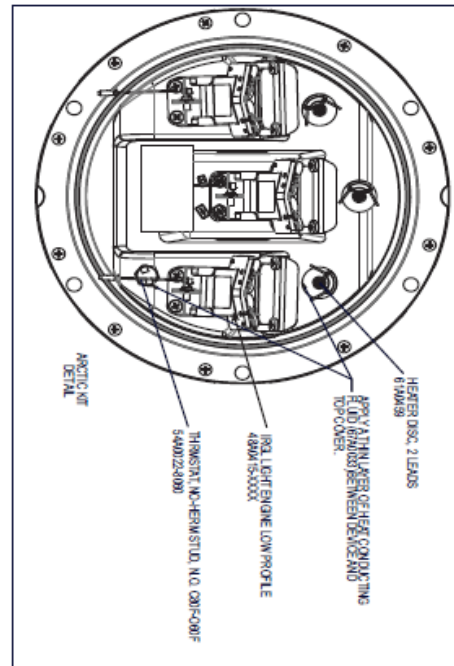
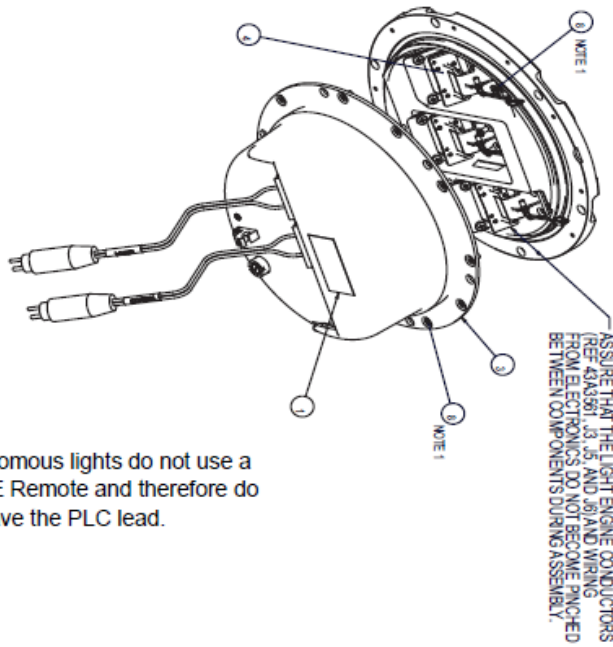

Autonomous lights do not use a BRITE Remote and therefore do not have the PLC lead.

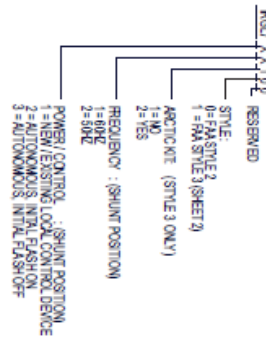
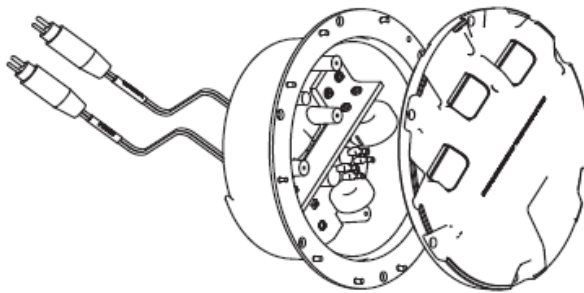

IRGL-XXXX

IRGL-XXXX

ITEM NO	PART NUMBER	DESCRIPTION	IRGL-XXXX QTY	IRGL-XXXX QTY
1	43A3561-X	GENERIC IN-PAVEMENT LIGHT LABEL	1	1
2	4448151	TOP CAP ASSY IRGL	1	1
3	4448184	LABELED BOTTOM COVER ASSEMBLY	1	1
4	43A415-100X	IRGL LIGHT ENGINE LOW PROFILE	3	3
5	5440122-000	THRUST/NO-HERM STUD, NO. 03F-030F	-	1
6	6159A18	HEATER DISC, 2 LEADS	-	3
7	6440184B	#4-4X 3/8 PANHD PHIL	-	3
8	6440125-10	M6 X 10 RT PHL SS	16	16
9	69A1034	#8 EXT LOCKWASHER	-	3
10	70A1028	MALE DISC 16-14AWG 25X.03 INSULATED	-	2
11	70A1029	FEMALE DISC 16-14AWG 25X.03 INSULATED	-	2

Figure 22: 44A6804 - L-852G Bottom Pan

Autonomous lights do not use a BRITE Remote and therefore do not have the PLC lead.

See Figure 14

SEE 43A3561 WIRING DIAGRAM. ENSURE THAT ALL SHUNT SARE PLACED ACCORDING TO POWER/CONTROL AND FREQUENCY OPTION. SHORTEN ALL WIRES TO PREVENT PINCHING AND INTERFERENCE

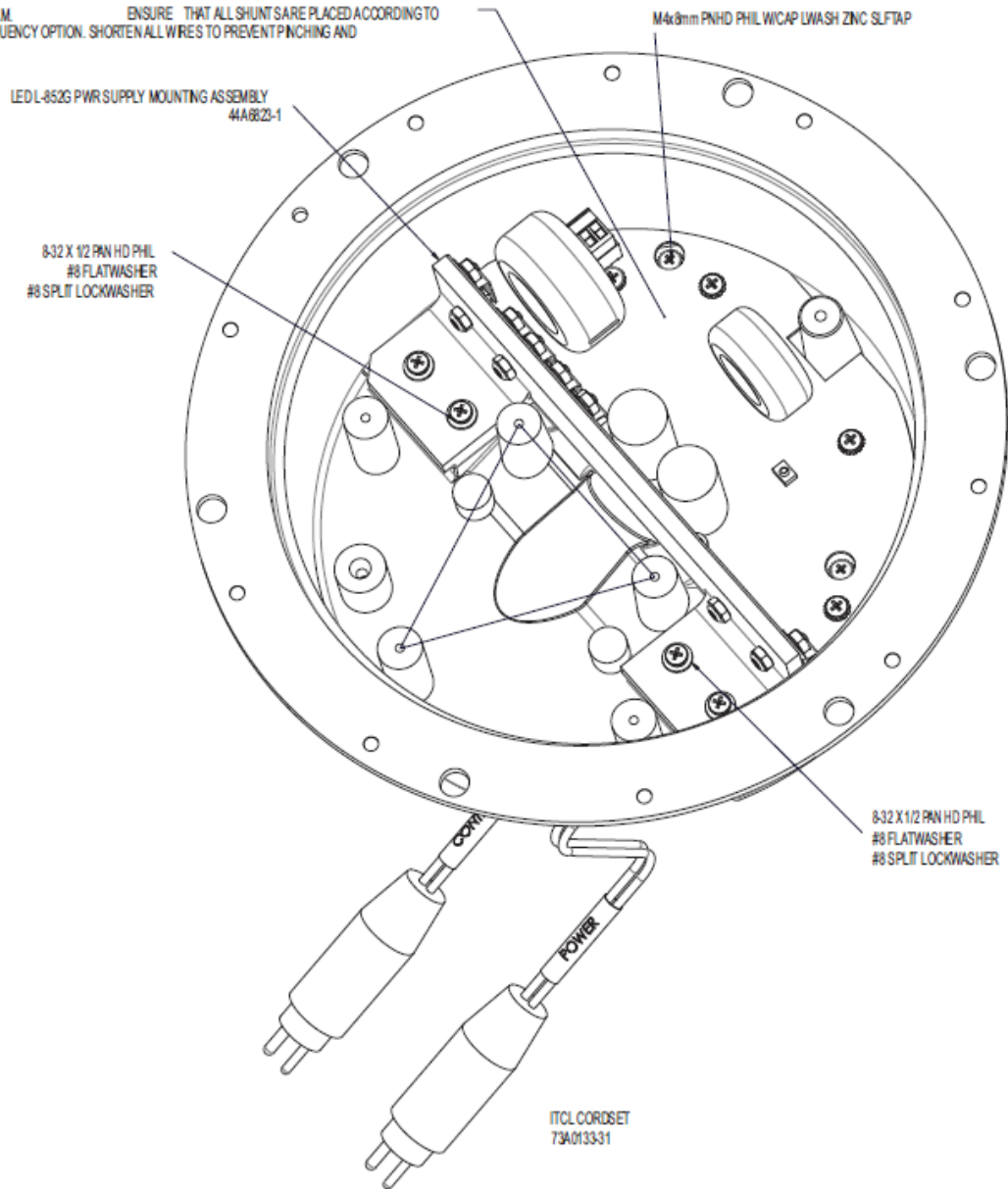
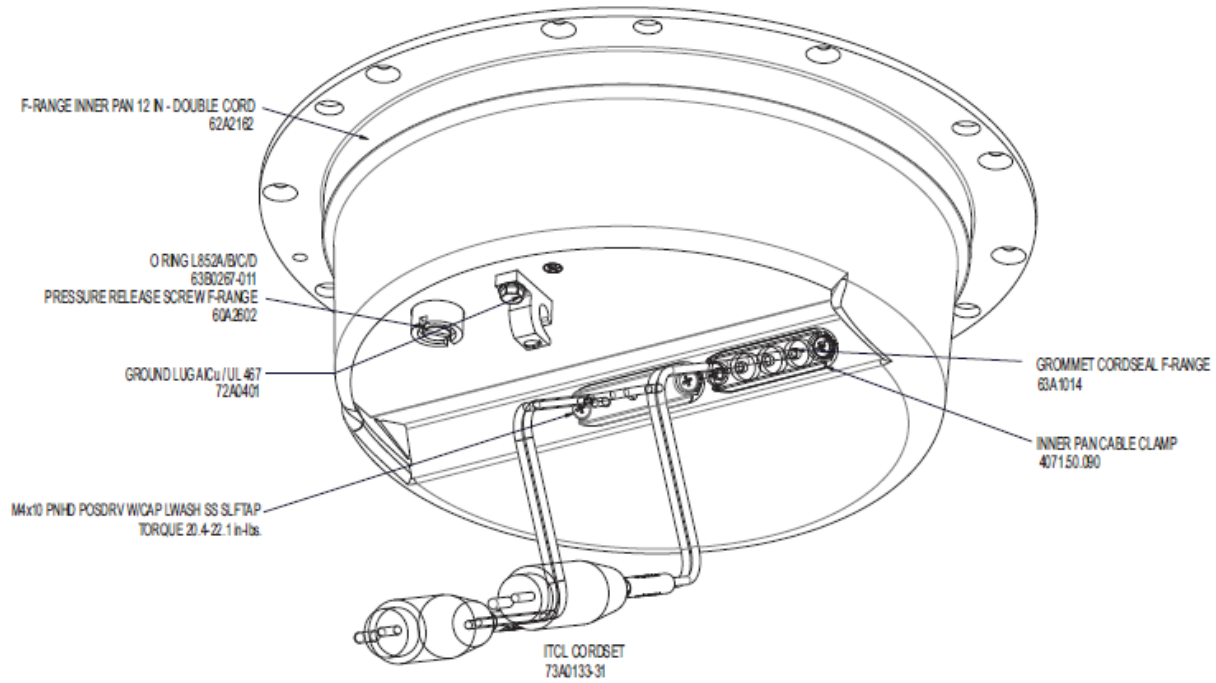

Figure 23: 44A6804 - L-852G Bottom Pan



Appendix A: SUPPORT

Our experienced engineers are available for support and service at all times, 24 hour/7 days a week. They are part of a dynamic organization making sure the entire ADB SAFEGATE is committed to minimal disturbance for airport operations.

ADB SAFEGATE Support

Technical Support – Global

Customers in Europe, the Middle East, Africa or Asia Pacific are more than welcome to our portal for technical support. Trained in all areas of system issues, troubleshooting, quality control and technical assistance, our highly experienced Technical support specialists are available 24 hours a day, seven days a week to provide assistance over the phone. In the Americas, we also offer live technical support.

Live Technical Support – Americas

If at any time you have a question or concern about your product, contact ADB SAFEGATE's US-based technical support specialists, available 24 hours a day, seven days a week, to assist you via phone.

ADB SAFEGATE Americas Technical Service & Support (US & Canada) :+1-800-545-4157

ADB SAFEGATE Americas Technical Service & Support (Canada): +1-905-631-1597

ADB SAFEGATE Americas Technical Service & Support (International): +1-614-861-1304

We can also be reached via email during regular business hours:

Airfield and Gate: techservice.us@adbsafegate.com

Gate: gateservice.us@adbsafegate.com

We look forward to working with you!

Before You Call

When you have an airfield lighting or system control system problem, prior to calling, please ensure the following:

- Review the product's manual and troubleshooting guide.
- Be located with the product ready to troubleshoot.
- Have all necessary information available: airport code/company name, customer id number, contact phone number/email address, product/part number.
- Have a *True RMS* meter available and any other necessary tools.

When calling about an issue with Safedock A-VDGS, we can serve you better if you collect the following information before you call:

- Relevant information regarding the issue you are calling about, such as gate number, flight number, aircraft type and time of the event.
- What, if any, actions have been taken to resolve the issue prior to the call.
- If available, provide a CCTV recording of the incident to aid in aligning the information from the Safedock log file.

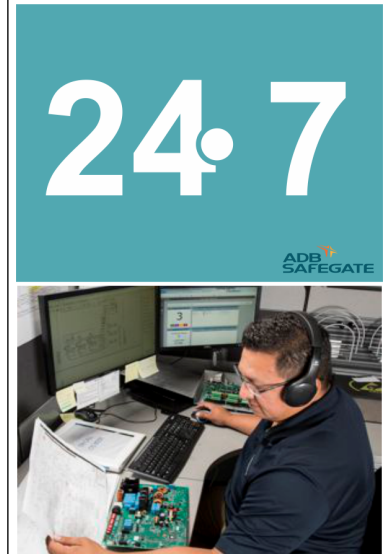

Note

For more information, see www.adbsafegate.com, contact ADB SAFEGATE Support via email at support@adbsafegate.com or

Europe: +32 2 722 17 11

Americas: +1 614 861 1304. Press 3 for technical service or press 4 for sales support.

China: +86 (10) 8476 0106

Middle East and Africa: +971 4 452 7575

A.1 ADB SAFEGATE Website

The ADB SAFEGATE website, www.adbsafegate.com, offers information regarding our airport solutions, products, company, news, links, downloads, references, contacts and more.

A.2 Recycling

A.2.1 Local Authority Recycling

The disposal of ADB SAFEGATE products is to be made at an applicable collection point for the recycling of electrical and electronic equipment. The correct disposal of equipment prevents any potential negative consequences for the environment and human health, which could otherwise be caused by inappropriate waste handling. The recycling of materials helps to conserve natural resources. For more detailed information about recycling of products, contact your local authority city office.

A.2.2 ADB SAFEGATE Recycling

ADB SAFEGATE is fully committed to environmentally-conscious manufacturing with strict monitoring of our own processes as well as supplier components and sub-contractor operations. ADB SAFEGATE offers a recycling program for our products to all customers worldwide, whether or not the products were sold within the EU.

ADB SAFEGATE products and/or specific electrical and electronic component parts which are fully removed/separated from any customer equipment and returned will be accepted for our recycling program.

All items returned must be clearly labeled as follows:

- For *ROHS/WEEE* Recycling
- Sender contact information (Name, Business Address, Phone number).
- Main Unit Serial Number.

ADB SAFEGATE will continue to monitor and update according for any future requirements for *EU directives* as and when *EU member states* implement new *regulations* and or *amendments*. It is our aim to maintain our *compliance plan* and assist our customers.



Powering Your Airport Performance from Approach to Departure

adbsafegate.com

Copyright © ADB SAFEGATE, all rights reserved

