



LINC 360

Remote

User Manual

96A0481, Rev. F, 2025/09/16



A.0 Disclaimer / Standard Warranty

CE certification

The equipment listed as CE certified means that the product complies with the essential requirements concerning safety and hygiene. The European directives that have been taken into consideration in the design are available on written request to ADB SAFEGATE.

ETL certification

The equipment listed as ETL certified means that the product complies with the essential requirements concerning safety and C22.2 No.180:13 (R2018) regulations. The CSA directives that have been taken into consideration in the design are available on written request to ADB SAFEGATE.

All Products Guarantee

ADB SAFEGATE will correct by repair or replacement per the applicable guarantee below, at its option, equipment or parts which fail because of mechanical, electrical or physical defects, provided that the goods have been properly handled and stored prior to installation, properly installed and properly operated after installation, and provided further that Buyer gives ADB SAFEGATE written notice of such defects after delivery of the goods to Buyer. Refer to the Safety section for more information on Material Handling Precautions and Storage precautions that must be followed.

ADB SAFEGATE reserves the right to examine goods upon which a claim is made. Said goods must be presented in the same condition as when the defect therein was discovered. ADB SAFEGATE further reserves the right to require the return of such goods to establish any claim.

ADB SAFEGATE's obligation under this guarantee is limited to making repair or replacement within a reasonable time after receipt of such written notice and does not include any other costs such as the cost of removal of defective part, installation of repaired product, labor or consequential damages of any kind, the exclusive remedy being to require such new parts to be furnished.

ADB SAFEGATE's liability under no circumstances will exceed the contract price of goods claimed to be defective. Any returns under this guarantee are to be on a transportation charges prepaid basis. For products not manufactured by, but sold by ADB SAFEGATE, warranty is limited to that extended by the original manufacturer. This is ADB SAFEGATE's sole guarantee and warranty with respect to the goods; there are no express warranties or warranties of fitness for any particular purpose or any implied warranties of fitness for any particular purpose or any implied warranties other than those made expressly herein. All such warranties being expressly disclaimed.

Standard Products Guarantee

Products manufactured by ADB SAFEGATE are guaranteed against mechanical, electrical, and physical defects (excluding lamps) which may occur during proper and normal use for a period of two years from the date of ex-works delivery, and are guaranteed to be merchantable and fit for the ordinary purposes for which such products are made.



Note

See your applicable sales agreement for a complete warranty description.

Replaced or repaired equipment under warranty falls into the warranty of the original delivery. No new warranty period is started for these replaced or repaired products.

FAA Certified products manufactured by ADB SAFEGATE

ADB SAFEGATE L858 Airfield Guidance Signs are warranted against mechanical and physical defects in design or manufacture for a period of 2 years from date of installation, per FAA AC 150/5345-44 (applicable edition).

ADB SAFEGATE LED products (with the exception of obstruction lighting) are warranted against electrical defects in design or manufacture of the LED or LED specific circuitry for a period of 4 years from date of installation, per FAA EB67 (applicable edition). These FAA certified constant current (series) powered LED products must be installed, interfaced and powered with and through products certified under the FAA Airfield Lighting Equipment Program (ALECP) to be included in this 4 (four) year warranty. This includes, but is not limited to, interface with products such as Base Cans, Isolation Transformers, Connectors, Wiring, and Constant Current Regulators.



Note

See your sales order contract for a complete warranty description.

Replaced or repaired equipment under warranty falls into the warranty of the original delivery. No new warranty period is started for these replaced or repaired products.

Liability



WARNING

Use of the equipment in ways other than described in the catalog leaflet and the manual may result in personal injury, death, or property and equipment damage. Use this equipment only as described in the manual.

ADB SAFEGATE cannot be held responsible for injuries or damages resulting from non-standard, unintended uses of its equipment. The equipment is designed and intended only for the purpose described in the manual. Uses not described in the manual are considered unintended uses and may result in serious personal injury, death or property damage.

Unintended uses, includes the following actions:

- Making changes to equipment that have not been recommended or described in this manual or using parts that are not genuine ADB SAFEGATE replacement parts or accessories.
- Failing to make sure that auxiliary equipment complies with approval agency requirements, local codes, and all applicable safety standards if not in contradiction with the general rules.
- Using materials or auxiliary equipment that are inappropriate or incompatible with your ADB SAFEGATE equipment.
- Allowing unskilled personnel to perform any task on or with the equipment.

Copyright Statement

This manual or parts thereof may not be reproduced, stored in a retrieval system, or transmitted, in any form or by any means, electronic, mechanical, photocopying, recording, nor otherwise, without the author's prior written consent.

This manual could contain technical inaccuracies or typographical errors. The author reserves the right to revise this manual from time to time in the contents thereof without obligation of the author to notify any person of such revision or change. Details and values given in this manual are average values and have been compiled with care. They are not binding, however, and the author disclaims any liability for damages or detriments suffered as a result of reliance on the information given herein or the use of products, processes or equipment to which this manual refers. No warranty is made that the use of the information or of the products, processes or equipment to which this manual refers will not infringe any third party's patents or rights. The information given does not release the buyer from making their own experiments and tests.

Table of Contents

1.0 Safety	1
1.1 Safety Messages.....	1
1.1.1 Introduction to Safety.....	2
1.1.2 Intended Use.....	2
1.1.3 Material Handling Precautions: Storage.....	3
1.1.4 Maintenance Safety.....	3
1.1.5 Arc Flash and Electric Shock Hazard.....	4
2.0 LINC 360 Remote	5
2.1 Manual Introduction.....	5
2.1.1 How to work with the manual.....	5
2.1.2 Terms.....	5
2.2 LINC 360 Remote Introduction.....	6
2.2.1 Individual Lamp Control & Monitoring System (ILCMS).....	6
2.2.2 General.....	12
2.2.3 Illustration.....	12
2.2.4 Checking the Device.....	13
2.2.4.1 Scope of Supply.....	13
2.2.4.2 Unpacking.....	13
2.2.4.3 Inspection.....	13
2.2.4.4 Storage.....	13
2.2.5 View of the Device with Connections.....	14
2.2.6 View of the Device with Connections.....	15
2.2.6.1 Construction.....	15
2.2.6.2 Block Diagram.....	16
2.2.7 Theory of Operation.....	17
2.2.7.1 Architecture.....	17
3.0 Installation	19
3.1 Installation in a Transformer Pit.....	19
3.2 Connection to the Series Transformer and the Light Fitting(s).....	20
3.3 Utility Device Enclosure Wiring Diagram.....	21
3.4 Earth Grounding.....	22
3.5 Safety Instructions.....	22
3.6 Replacing a LINC 360 Remote.....	22
4.0 Modes of Operation of an LINC 360 Remote	25
4.1 Frequency Scan.....	25
4.2 Operating Mode.....	25
4.2.1 Self-test Mode.....	25
4.3 Switch Status of the Connected Lights.....	25
4.4 Switch Status under Special Circumstances.....	25
4.4.1 Power-up Mode.....	26
4.4.2 Fail-safe Mode.....	26
4.4.3 Delayed Start/Stop.....	26
4.5 Spreadsheet.....	26
4.5.1 A sample spreadsheet would contain:.....	27
5.0 Parts	29
5.1 Spare Components.....	29
A.0 SUPPORT	31
A.1 ADB SAFEGATE Website.....	31
A.2 Recycling.....	32
A.2.1 Local Authority Recycling.....	32
A.2.2 ADB SAFEGATE Recycling.....	32

List of Figures

Figure 1: LINC 360 Remote Single	12
Figure 2: Nameplate of the LINC 360 Remote Dual Channel	13
Figure 3: View of the LINC 360 Remote Dual Channel	14
Figure 4: View of the LINC 360 Utility Device Cabinet	15
Figure 5: Block Diagram of the LINC 360 Remote Dual.....	16
Figure 6: Typical LINC 360 Topology	17
Figure 7: Series Circuit Controller/Fixture Architecture	18
Figure 8: Diagram of LINC 360 Installation in Series Circuit.....	19
Figure 9: Remote Max. Bending Radius.....	19
Figure 10: Connection to Series Transformer and Light Fitting.....	20
Figure 11: Connection to a Series Circuit Isolation Transformer and Light Fitting	22
Figure 12: Spreadsheet Example.....	26

List of Tables

Table 1: Terms.....	5
Table 2: Ordering Code: Controllers.....	11
Table 3: Ordering Code: Remotes.....	12
Table 4: Ordering Code: Controllers.....	29
Table 5: Ordering Code: Remotes.....	29
Table 6: Ordering Code: Spare Parts	29

1.0 Safety

Introduction to Safety

This section contains general safety instructions for installing and using ADB SAFEGATE equipment. Some safety instructions may not apply to the equipment in this manual. Task- and equipment-specific warnings are included in other sections of this manual where appropriate.

1.1 Safety Messages

HAZARD Icons used in this manual

For all HAZARD symbols in use, see the Safety section. All symbols must comply with ISO and ANSI standards.

Carefully read and observe all safety instructions in this manual, which alert you to safety hazards and conditions that may result in personal injury, death or property and equipment damage and are accompanied by the symbols shown below.

	<p>WARNING Failure to observe a warning may result in personal injury, death or equipment damage.</p>
	<p>DANGER – Risk of electrical shock or ARC FLASH Disconnect equipment from line voltage. Failure to observe this warning may result in personal injury, death, or equipment damage. ARC Flash may cause blindness, severe burns or death.</p>
	<p>WARNING – Wear personal protective equipment Failure to observe may result in serious injury.</p>
	<p>WARNING – Do not touch Failure to observe this warning may result in personal injury, death, or equipment damage.</p>
	<p>CAUTION Failure to observe a caution may result in equipment damage.</p>
	<p>ELECTROSTATIC SENSITIVE DEVICES This equipment may contain electrostatic devices.</p>

Qualified Personnel

	<p>Important Information The term qualified personnel is defined here as individuals who thoroughly understand the equipment and its safe operation, maintenance and repair. Qualified personnel are physically capable of performing the required tasks, familiar with all relevant safety rules and regulations and have been trained to safely install, operate, maintain and repair the equipment. It is the responsibility of the company operating this equipment to ensure that its personnel meet these requirements. Always use required personal protective equipment (PPE) and follow safe electrical work practice.</p>
--	--

1.1.1 Introduction to Safety



CAUTION

Unsafe Equipment Use

This equipment may contain electrostatic devices, hazardous voltages and sharp edges on components

- Read installation instructions in their entirety before starting installation.
- Become familiar with the general safety instructions in this section of the manual before installing, operating, maintaining or repairing this equipment.
- Read and carefully follow the instructions throughout this manual for performing specific tasks and working with specific equipment.
- Make this manual available to personnel installing, operating, maintaining or repairing this equipment.
- Follow all applicable safety procedures required by your company, industry standards and government or other regulatory agencies.
- Install all electrical connections to local code.
- Use only electrical wire of sufficient gauge and insulation to handle the rated current demand. All wiring must meet local codes.
- Route electrical wiring along a protected path. Make sure they will not be damaged by moving equipment.
- Protect components from damage, wear, and harsh environment conditions.
- Allow ample room for maintenance, panel accessibility, and cover removal.
- Protect equipment with safety devices as specified by applicable safety regulations
- If safety devices must be removed for installation, install them immediately after the work is completed and check them for proper functioning prior to returning power to the circuit.

Failure to follow these instructions can result in serious injury, death or equipment damage

Additional Reference Materials



Important Information

- IEC – International Standards and Conformity Assessment for all electrical, electronic and related technologies.
- IEC 60364 – Electrical Installations in Buildings.
- CSA – C22.2 No.180:13 (R2018), series isolating transformers for airport lighting.
- FAA Advisory: AC 150/5340-26 (current edition), Maintenance of Airport Visual Aid Facilities.
- Maintenance personnel must refer to the maintenance procedure described in the ICAO Airport Services Manual, Part 9.
- ANSI/NFPA 79, Electrical Standards for Metalworking Machine Tools.
- National and local electrical codes and standards.

1.1.2 Intended Use



CAUTION

Use this equipment as intended by the manufacturer.

This equipment is designed to perform a specific function. Do not use this equipment for other purposes.

Failure to follow this instruction can result in serious injury, death or equipment damage.

1.1.3 Material Handling Precautions: Storage



CAUTION

Improper Storage

Store this equipment properly

- If equipment is to be stored prior to installation, it must be protected from the weather elements and kept free of condensation and dust.

Failure to follow this instruction can result in equipment damage

1.1.4 Maintenance Safety



DANGER

ELECTRIC SHOCK HAZARD

THIS EQUIPMENT MAY CONTAIN ELECTROSTATIC DEVICES

- DO NOT OPERATE A SYSTEM THAT CONTAINS MALFUNCTIONING COMPONENTS. IF A COMPONENT MALFUNCTIONS, TURN THE SYSTEM OFF IMMEDIATELY.
- DISCONNECT AND LOCK OUT ELECTRICAL POWER.
- ALLOW ONLY QUALIFIED PERSONNEL TO MAKE REPAIRS OR REPLACE MALFUNCTIONING COMPONENTS ACCORDING TO INSTRUCTIONS PROVIDED IN MANUAL.

FAILURE TO FOLLOW THESE INSTRUCTIONS CAN RESULT IN DEATH OR EQUIPMENT DAMAGE

1.1.5 Arc Flash and Electric Shock Hazard



DANGER

SERIES CIRCUITS HAVE HAZARDOUS VOLTAGES

THIS EQUIPMENT PRODUCES HIGH VOLTAGES TO MAINTAIN THE SPECIFIED CURRENT - DO NOT DISCONNECT WHILE ENERGIZED.

- ALLOW ONLY QUALIFIED PERSONNEL TO PERFORM MAINTENANCE, TROUBLESHOOTING, AND REPAIR TASKS.
- ONLY PERSONS WHO ARE PROPERLY TRAINED AND FAMILIAR WITH ADB SAFEGATE EQUIPMENT ARE PERMITTED TO SERVICE THIS EQUIPMENT.
- AN OPEN AIRFIELD CURRENT CIRCUIT IS CAPABLE OF GENERATING >5000 VAC AND MAY APPEAR OFF TO A METER.
- NEVER UNPLUG A DEVICE FROM A CONSTANT CURRENT CIRCUIT WHILE IT IS OPERATING; ARC FLASH MAY RESULT.
- DISCONNECT AND LOCK OUT ELECTRICAL POWER.
- ALWAYS USE SAFETY DEVICES WHEN WORKING ON THIS EQUIPMENT.
- FOLLOW THE RECOMMENDED MAINTENANCE PROCEDURES IN THE PRODUCT MANUALS.
- DO NOT SERVICE OR ADJUST ANY EQUIPMENT UNLESS ANOTHER PERSON TRAINED IN FIRST AID AND CPR IS PRESENT.
- CONNECT ALL DISCONNECTED EQUIPMENT GROUND CABLES AND WIRES AFTER SERVICING EQUIPMENT. GROUND ALL CONDUCTIVE EQUIPMENT.
- USE ONLY APPROVED ADB SAFEGATE REPLACEMENT PARTS. USING UNAPPROVED PARTS OR MAKING UNAPPROVED MODIFICATIONS TO EQUIPMENT MAY VOID AGENCY APPROVALS AND CREATE SAFETY HAZARDS.
- CHECK THE INTERLOCK SYSTEMS PERIODICALLY TO ENSURE THEIR EFFECTIVENESS.
- DO NOT ATTEMPT TO SERVICE ELECTRICAL EQUIPMENT IF STANDING WATER IS PRESENT. USE CAUTION WHEN SERVICING ELECTRICAL EQUIPMENT IN A HIGH-HUMIDITY ENVIRONMENT.
- USE TOOLS WITH INSULATED HANDLES WHEN WORKING WITH AIRFIELD ELECTRICAL EQUIPMENT.

FAILURE TO FOLLOW THESE INSTRUCTIONS CAN RESULT IN DEATH OR EQUIPMENT DAMAGE

2.0 LINC 360 Remote

LINC 360 Remotes – User Manual

General notice: other product names used here are for identification purposes only and may be trademarks of their respective companies.



2.1 Manual Introduction

- This document provides detailed information how to correctly install and maintain LINC 360 Remotes.

2.1.1 How to work with the manual

1. Be familiar with the structure and content.
2. Carry out the actions completely and in the given sequence.

2.1.2 Terms

General Aviation Terms and Acronyms that you may encounter using our manuals.

Table 1: Terms

Term	Definition
ALCMS	Acronym for Airfield Lighting Control Monitoring System. An ALCMS incorporates many components that are used to control and monitor an airport's entire airfield lighting system. The ALCMS may include Touch Screens for lighting control, Maintenance Center(s) for data viewing and archiving, Electrical Lighting equipment for CCR control and monitoring.
CCR	Abbreviation for Constant Current Regulator. The CCRs are located within the Airfield Lighting Vault (ALV). They produce a constant current output to the airfield series circuit that light the airfield lighting fixtures.
LINC 360 Remote, Controller, PC	ADB SAFEGATE's trademarked abbreviation that describes the future proofing technology used to transmit and receive data across airfield lighting series circuit cabling.
Remote	Unit installed in the airfield (normally in pull-pits or base cans) which provides control and monitoring of individual or blocks of light fixtures. Each Remote has its own unique address for control and monitoring data communication to the Controller.
Controller	Unit installed within the lighting vault that provides the means for data communication on the airfield series circuit cables. The Controller is connected in parallel (across) to the output of the CCR. Each series circuit that contains Remotes must also have a Controller installed at the CCR.

Table 1: Terms

Term	Definition
Control Panel	This term is used to reference the device used to control and monitor the controllable stopbars and the associated lighting equipment. The control panel could be either an L-821 style push-button panel or a Touchscreen style control panel. The control panel is located in the Air Traffic Control Tower cab.
SMGCS	Acronym which means Surface Movement Guidance and Control System. SMGCS is an organized system created to improve and enhance low visibility operations.

2.2 LINC 360 Remote Introduction

2.2.1 Individual Lamp Control & Monitoring System (ILCMS)

Compliance with Standards

FAA:	Approved for use with SMGCS Systems. This includes both Stop Bar and Runway Guard Light control/monitoring according to AC 150/5340-30 (Current Edition), AC 150/5345-56BAC (Current Edition); manufactured to AC 120-57 (Current Edition).
ICAO:	Complies with CAT I/II/III ICAO lamp supervision requirements. Supports A-SMGCS for enhanced aircraft guidance in all weather conditions. Supports safety of airport operations by integration in runway safety nets.

Uses

LINC 360 provides distributed intelligence in the airfield to control and monitor a variety of airfield lighting devices. It can be used in the following applications:

- Key component of (Advanced-) Surface Movement Guidance Control Systems: (A-)SMGCS
- Stop bar control and monitoring; taxiway routing support.
- Elevated and in-pavement Runway Guard Light (RGL) control and monitoring, CAT II/III monitoring support.
- Failed-lamp detection and location identification.
- Interface with aircraft/vehicle presence sensors (option).
- Selective control and monitoring of various airfield lighting devices.

The system provides relevant information concerning the status of connected airfield lighting devices to both airport maintenance and air traffic control personnel.

Furthermore LINC 360:

- Supports the optimization of traffic volume, flexibility, maintainability and airside safety.
- Ensures reliable guidance for aircraft on the ground during CAT I, II or III conditions, increasing safety and reducing the risk of runway incursions.
- Automatically detects and reports lamp failures, decreasing downtime and maintenance costs.

Customer Benefits

- Faster, predictable and more robust power line carrier communication method ensures highest reliability, even for long airfield circuits that contain large number of lamps.
- Increased number of slots per day as a result of higher traffic throughput and better control of ground traffic movements.
- Flexible routing functionality and safe operation under all traffic and environmental conditions resulting in reduced ATC workload.
- Precise control of each segment of runways, taxiways, and stop bar lighting.
- Adjacent lamp failure reporting.
- Most economic solution for modernization projects through power line communication on existing circuits.

- Easy future upgrade of installed LINC 360 systems.
- A step-by-step migration strategy can then be implemented.
- Optimized planning of runway and taxiway maintenance downtimes.
- Worldwide availability of our regional Technical Service staff for technical support and site services on short notice.

LINC 360 Technology

- Communicates using a radio frequency signal imposed on the high- voltage airfield series circuit cable - no separate communication cable needed.
- Communication quality is automatically optimized for each series circuit in a permanent background process.
- New communication principle together with forward error correction drastically reduces signal disturbance caused by impulse and narrow band interferences.
- Main system elements: LINC 360 Controller (in the substation), LINC 360 Remotes (for individual control and monitoring of lights in the field). In addition, LINC 360 Utility Device for communication with and energy supply for local field sensors.

Features

- No separate communication cable required. RF signal on high voltage power cable for lighting control.
- Most cost-effective and proven solution for existing ground lighting systems.
- User friendly integrated web server allows easy operation and system status recognition.
- Up to 11 different frequency bands can be used in parallel, and up to 32 different timeslots which allow an increase in the number of independent communication channels up to 176.
- Fast and predictable switching times through the use of reliable communication methods and limited repeater levels.
- Synchronizing of control systems in different vaults by Ethernet in compliance with IEEE 1588.
- Single Frequency Network system includes an automatic network configuration function. This functionality provides for dynamic communication adaptation in all environmental conditions (such as humidity variation). The system dynamically checks repeater settings and automatically sets them, even if a Remote in the communication path has failed.
- Less crosstalk due to symmetrical design of coupling components (transmit and receive path), independent communication channels and lower transmission power compared to similar systems in the market.
- Can be used as a stand-alone monitoring system or integrated with an Airfield Lighting Control System (ALCS).
- Individual control of different functions in one lamp circuit. For example, a combination of Stop Bar and Lead-In Circuit.
- Optional Runway Guard Light Remotes, automatic start and net-synchronous Wig-Wag operation, independent from Controller meeting FAA requirements.
- Firmware and application software can be downloaded into either the Controller (substation) or Remotes (field units).
- State-of-the-art diagnostic tools provide a quick overview about communication behavior. Network management system provides detailed routing statistics to ensure reliable communication quality.
- Field sensors can be integrated via Utility Devices into the LINC 360 lamp control and monitoring circuit for detection and transmission of local surveillance information via power line communication.
- Able to work with any kind of CCR and designed for 40 Ampere peak current.

Main Characteristics and Figures

- Up to 300 Remotes or AXON EQ Lights per circuit, providing a potential of 600 individually addressable lights per circuit.
- Up to 20 km roundtrip circuit length.
- Configurable block evaluation modes include full feedback, small sample feedback, and optimistic feedback.
- Can command 10 blocks to 10 distinct states with one power-line message. Can command all blocks to one state with one powerline message.
- Switches up to 120 lights in 10 different groups in less than 1 second.
- Switches 5 stopbar/lead-on lights simultaneously and presents real-back indication in less than 1 second.
- Status poll provides detailed Remote and lamp parameters.

Integrated System Control

Overall system configuration and control is realized via a control process with integrated web server for configuration and maintenance.

- Each circuit is equipped with a microprocessor-controlled Controller for tracking, recording and management of state of all Remotes in the circuit.
- The Controller communicates with all the Remotes (or integrated AXON EQ light fixtures) in a circuit and polls all lamps independent from the control system.

Overall System Specifications

Description	Remote	Controller
Operating temperature	-40 °C to +65 °C	0 °C to +55 °C
Storage temperature	-55 °C to +85 °C	-40 °C to +75 °C
Operating humidity	Max. 100 %	Max. 95 % non condensing
Series circuit operating voltage	-	Max. 5000 V AC RMS
Min. / max. Power line current	1.8 up to 8.25A RMS	1.8 up to 8.25A RMS
Maximum Open Circuit Voltage		10,000 V AC RMS
Series circuit peak voltage	-	Max. 15 kV
Maximum switching power secondary side of transformer	300 W (single Remote) Ch A + Ch B < 300 W (dual)	-
Maximum circuit load (CCR power)	-	30 kVA

Description	Remote	Controller
Enclosure protection level	IP 68 / NEMA 6 P	IP 20
LAN connection to upper control system	-	IEEE 802.3 100 BaseT / IEEE1588 PTP
Net voltage of power supply	-	115 - 230 V AC ±15 %, 50/60 Hz
MTBF	> 200.000 h	> 200.000 h
Indicative MTTR	< 30 min	< 60 min
Lightning protection	20 kA (8/20 micro sec.)	17 kA (8/20 micro sec.)

Description	Remote	Controller
EMC (CE approved)	Compliant to the EN 61000-6-4 (EMC emission standard) Compliant to the EN 61000-6-2 and 6-5 (EMC immunity standard)	
Power Up Mode	On; Off; Flashing; Maintained (last commanded state)	
Fail-Safe Mode	On; Off; Flashing, Maintained (last commanded state)	
Number of controlled and monitored lamps per unit	1 or 2	Up to 300 Remotes or 600 lights, if dual Remotes are used
Number of Utility Devices per circuit	-	Max. 16
Transmit Frequency	11 different frequency bands between 20 kHz and 200 kHz	
Data transmission rate power line	Up to 8 kbps	Up to 8 kbps

Description	Remote	Controller
Dimensions (W x H x D) / Weight	204 x 76 x 140 mm / 1.2 kg (single Remote) / 1.3 kg (dual)	420.7 x 177.8 x 504.8 mm / 29.82 kg
Lamp failure reaction	Short is placed across isolation transformer as soon as lamp filament failure detected	
Power Storage after Power-Off	Remote does not reset and remains in operation, if circuit power loss < 2 sec. Remote start up time is less than 1 sec.	

Circuit Specifications

Cable type L-824 is recommended, for example FLYCY or equivalent. The following parameters (*) represent the specific characteristic needed in an equivalent L-824 cable. Reuse of existing installations and layout with maximum cable length or number of lights to be verified.

Cable type (specification)	L-824
Capacity of the cable	<165 nF/km ¹
Inductance of the cable	<0.20 mH/km ¹
Typical impedance (125 kHz)	35 Ohm
Attenuation of the signal at 125 kHz	<5.8 dB/km ¹
Length of serial circuit	20 km roundtrip (12.4 miles) maximum
Insulation resistance of the series circuit against the L-824 shield or ground	50 Megaohms minimum ²
Secondary transformer attenuation	≤ 23 dB at 100 kHz ¹

¹Contact ADB SAFEGATE for support

²Technical requirement, not excluding ICAO/FAA compliance

System Overview

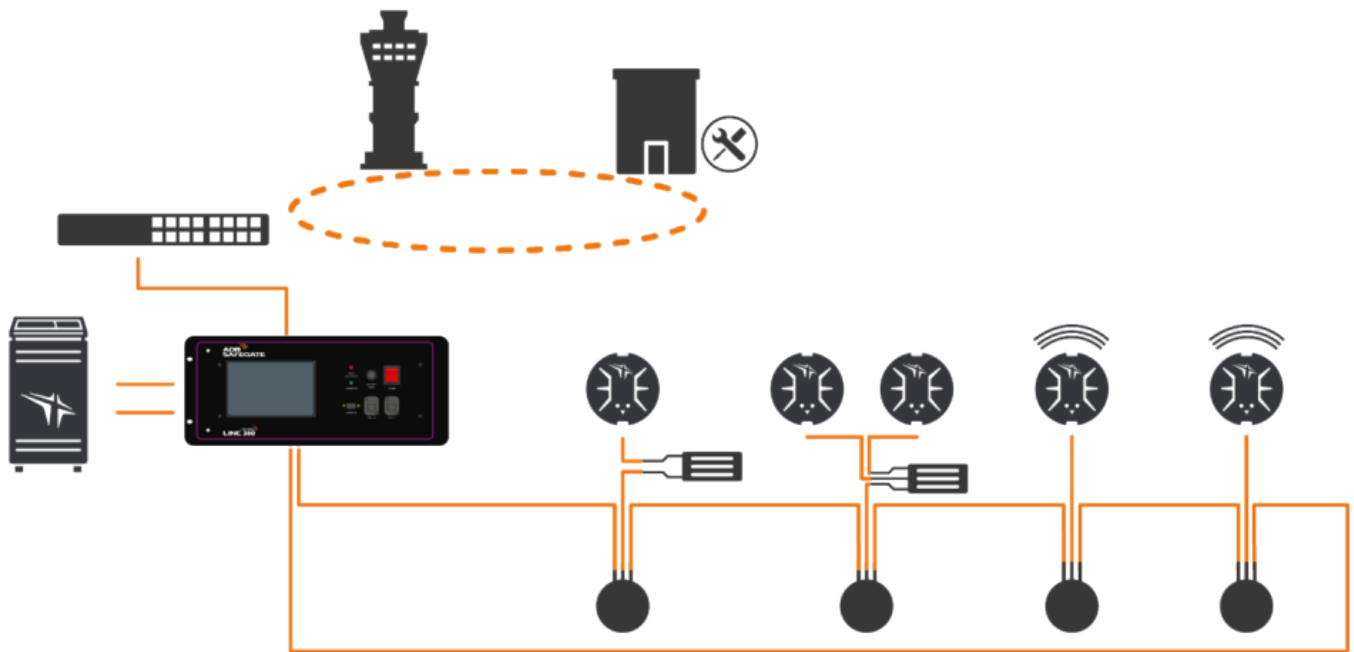

Airside 4.0

To enable Airside 4.0 use cases, such as Axon EQ Sealing Leakage Detection or LINC 360 Performance Monitoring, an internet Cloud Connection is needed. There are several ways to accomplish this as shown in the following figure. Contact your Sales Representative for more information.

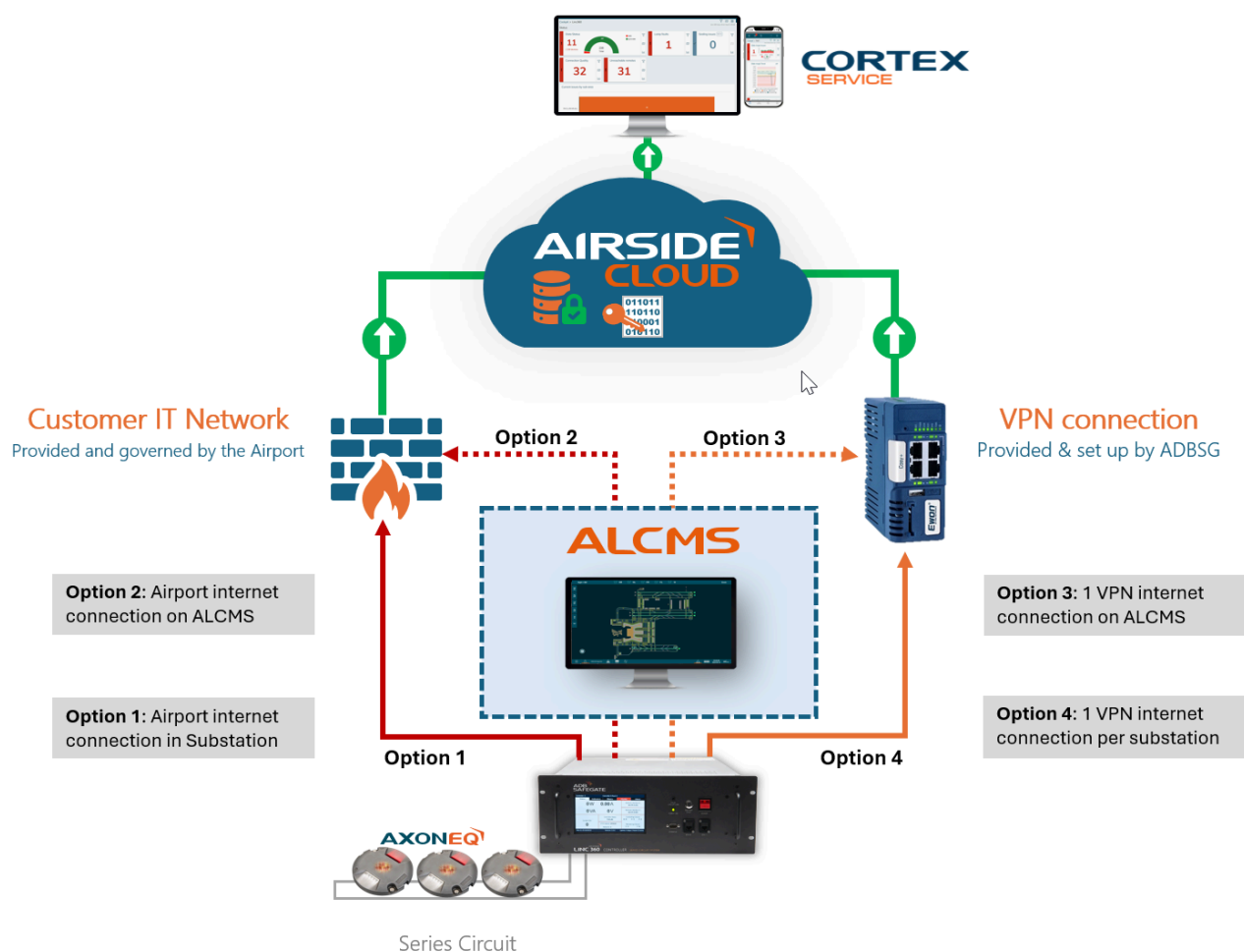

Table 2: Ordering Code: Controllers

Description	Part No.
LINC 360 Controller, 19" Rack Mount, EU plug	LINCC0000000101
LINC 360 Controller, Wall Mount, Door Open Left (EU)	LINCC0000000201
LINC 360 Controller, Wall Mount, Door Open Right (EU)	LINCC0000000301
LINC 360 Controller, 19" Rack Mount, US plug	LINCC0000000111
LINC 360 Controller, Wall Mount, Door Open Left (US)	LINCC0000000211
LINC 360 Controller, Wall Mount, Door Open Right (US)	LINCC0000000311
LINC 360 Controller, 19" Rack Mount, UK plug	LINCC0000000121
LINC 360 Controller, Wall Mount, Door Open Left (UK)	LINCC0000000221
LINC 360 Controller, Wall Mount, Door Open Right (UK)	LINCC0000000321
LINC 360 Controller, 19" Compact (no flanges)	LINCC0000000501

Table 3: Ordering Code: Remotes

Description	Part No.
LINC 360 Single Channel Remote, FAA Style 7	AGC4170
LINC 360 Single Channel Remote, FAA Style 8	AGC4180
LINC 360 Single Channel Remote, FAA Style 7, Initial Flash Off	AGC4270
LINC 360 Single Channel Remote, FAA Style 7, Initial Flash On	AGC4370
LINC 360 Dual Channel Remote, FAA Style 7	AGC5170
LINC 360 Dual Channel Remote, FAA Style 7, Channel A Initial Flash On, Channel B Initial Flash Off	AGC5470
LINC 360 Utility Device (Above Ground Installation only)	AGC6110
LINC 360 Power Remote 13.5 Vdc	LINCP00000130001



Note

Axon EQ with integrated modem: please consult the Axon Lights Datasheet.

2.2.2 General

The LINC 360 Remotes are intelligent powerline addressable field devices that operate on the secondary side of airfield isolation transformers. They serve as Remote nodes in a Controller/ Remote network that is controlled by a LINC 360 Controller. The LINC 360 Remote is available in the following four versions:

- LINC 360 Remote single channel for controlling one light (airfield ground lighting)
- LINC 360 Remote dual channel for controlling two lights (airfield ground lighting)
- LINC 360 Remote RGL single channel for network-synchronized blinking after switching on, without Controller synchronization (Runway Guard Light)
- LINC 360 Remote RGL dual channel for continuous, network-synchronized, alternating blinking of both channels after switching on, without Controller synchronization (Runway Guard Light)

In terms of construction, they differ in the number of channels which in turn determines the number of lights that can be switched.

RGL Remotes leave the factory with a special configuration that ensures synchronous start-up after power-up of the regulator and network-synchronized blinking without Controller synchronization. The factory setting also includes the choice whether the blinking is to start with “initial flash On” or “Off”. This option makes it possible to have different groups of Remotes flash alternately, leveling the load on the constant current regulator caused by synchronous switching of all groups of Remotes.

In the following sections all four devices will be referred to as LINC 360 Remotes.

2.2.3 Illustration

Figure 1: LINC 360 Remote Single



2.2.4 Checking the Device

2.2.4.1 Scope of Supply

The LINC 360 Remote single channel is supplied with two 12-inch (30 cm) cord-set cables for connection to the series transformer and the light.

The LINC 360 Remote dual channel is supplied with three 12-inch (30 cm) cord-set cables, 1 for connection to the series transformer and 2 for connection to the lights.

The LINC 360 Remote single channel RGL is supplied with two 12-inch (30 cm) cord-set cables for connection to the series transformer and the light, adjusted at the factory for configured start-up after switching on (consistent adjustment for all RGL Remotes in a project).

The LINC 360 Remote dual channel RGL is supplied with three 12-inch (30 cm) cord-set cables, 1 for connection to the series transformer and 2 for connection to the lights; adjusted at the factory for configured start-up after switching on.

See “Parts” for the complete list of remote variants.

2.2.4.2 Unpacking

The device has been fully assembled, tested and packed at the factory and has no internal transport locks.

2.2.4.3 Inspection

The delivery must be checked to make sure that it is complete and in perfect condition. The supplier must be notified of any complaints within 2 weeks. After this period, complaints about the delivery will not be accepted. In the event of the goods being returned, the same transport packaging must be used. See [Figure 2](#).

The number on the nameplate must be checked against the order number on the delivery note.

The nameplate is located on the side of the device (example: LINC 360 Remote dual channel).

Figure 2: Nameplate of the LINC 360 Remote Dual Channel



For commissioning, the serial number on the nameplate (e.g. serial number 4015000220, see [Figure 2](#)) must be recorded. This is then utilized for installation and configuration.

2.2.4.4 Storage

When storing the device, it is advisable to leave it in its original packaging. The storage temperature is shown in “[Technical Specifications](#)”.

Storage Temperature: Remote: -67°F to +167°F (-55°C to +85°C)

2.2.5 View of the Device with Connections

Figure 3: View of the LINC 360 Remote Dual Channel

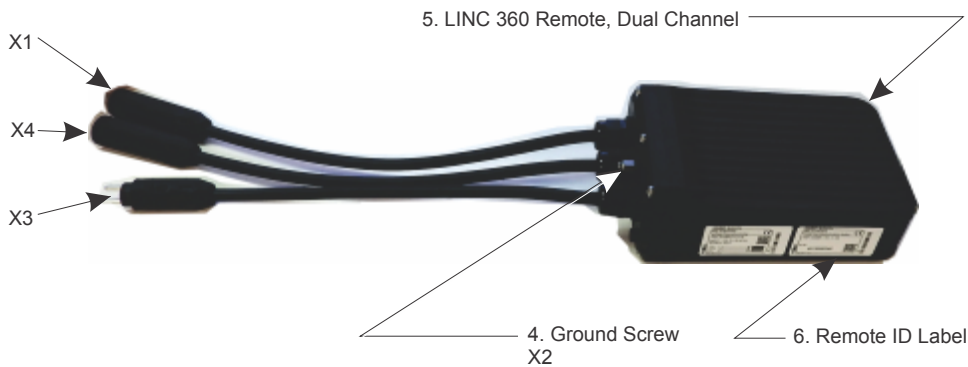

1. Cable with 2-pin plug (in compliance with FAA L-823) for connection to the series circuit isolation transformer (X3)
2. Cable with 2-pin socket (in compliance with FAA L-823) for connection to the light on channel A (X1)
3. Cable with 2-pin socket (in compliance with FAA L-823) for connection to the light on channel B (for dual Remote only) (X4)
4. Ground cable connection (X2)
5. LINC 360 Remote housing
6. LINC 360 Remote Label for Remote ID number.



Note

See nameplate of LINC 360 Remote (Figure 2) for identification of connections marked "X".

2.2.6 View of the Device with Connections

Figure 4: View of the LINC 360 Utility Device Cabinet

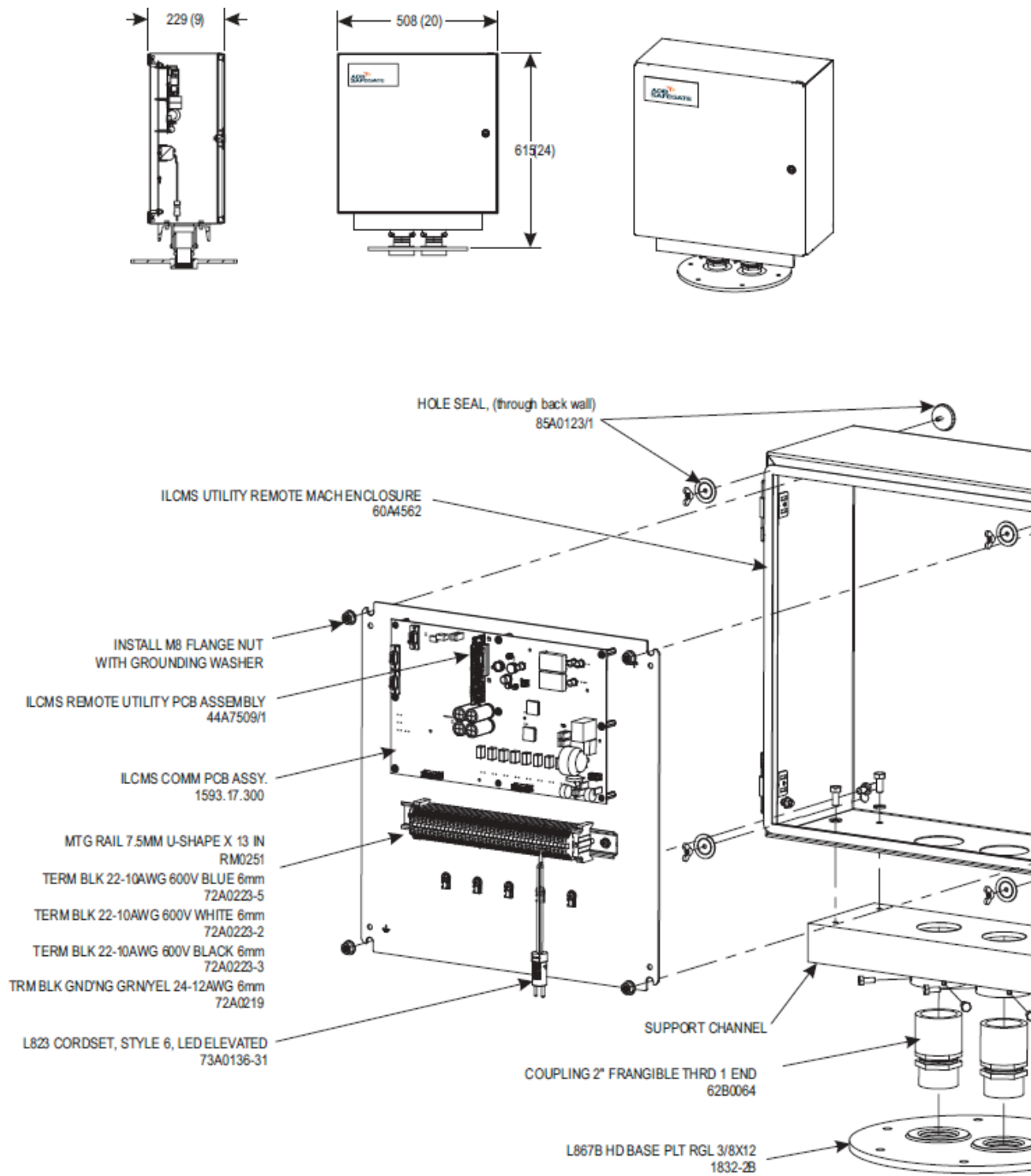

Note

See the remote cabinet wiring diagram for connections.

2.2.6.1 Construction

The LINC 360 Remote is sealed to make it watertight and gas-tight and must not be opened.



Note

Once the Remote has been opened, the warranty is void.
A defective or open Remote must be returned to the manufacturer.

2.2.6.2 Block Diagram

Figure 5: Block Diagram of the LINC 360 Remote Dual

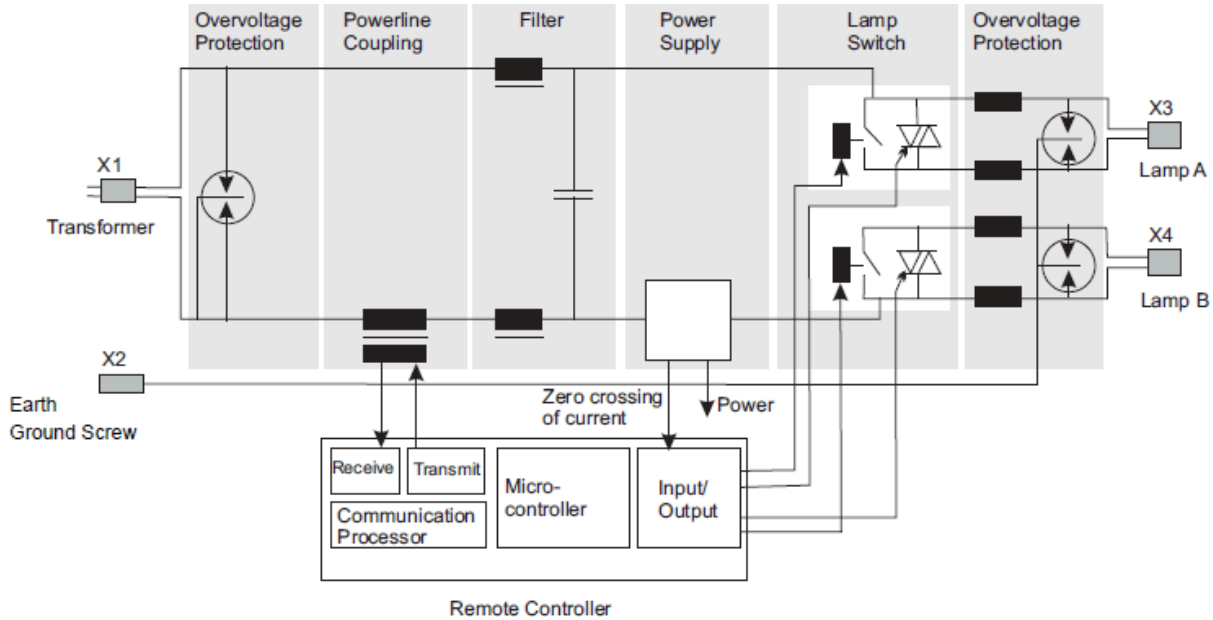

2.2.7 Theory of Operation

Background Information: LINC 360 uses power line carrier (PLC) technology to communicate between controlling units on an airfield lighting series circuit. A LINC 360 system typically consists of one high voltage modem, or Controller installed behind the Constant Current Regulator (CCR) powering the airfield lighting circuit and Remotes placed with individual lights in the field or lights with integrated modems (Axon EQ). A typical LINC 360 topology is provided in [Figure 6](#).

Figure 6: Typical LINC 360 Topology

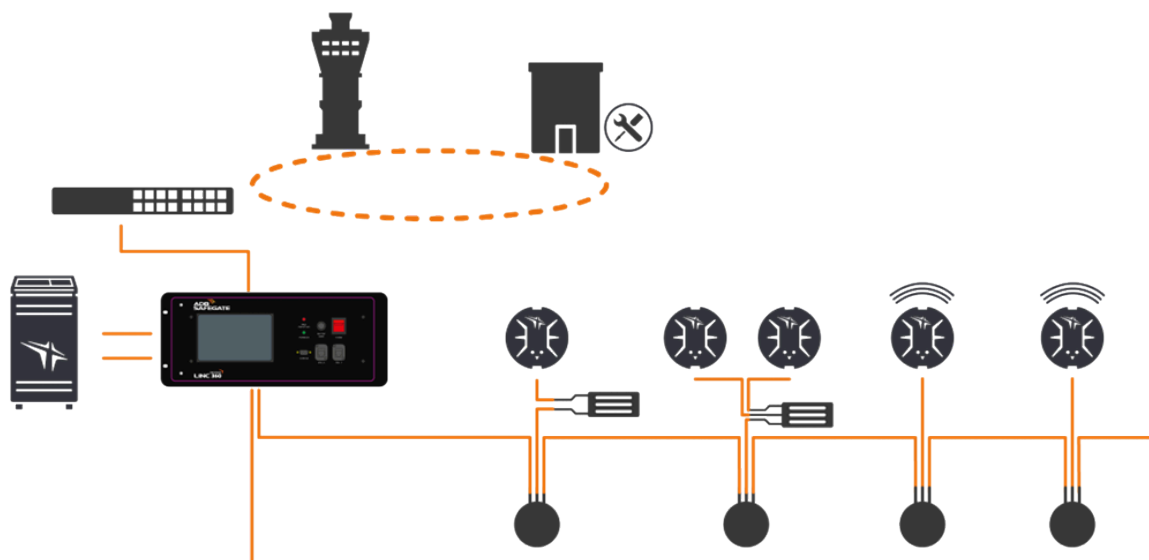

2.2.7.1 Architecture

[Figure 7](#) depicts the general nature of the system components and their interactions. The “Control System” is an external ALCMS system that provides controlling commands and digests Controller and Fixture status reports. There is typically only one control system in the architecture. The “Controller” is the high voltage modem that communicates commands to and receives status from the fixtures. There can be many Controllers in a given system. Controllers digest commands from the control system and provide status to it. Controllers also communicate among themselves to maintain communication timing synchronization. Each Controller communicates with the fixtures on its respective circuit.

Figure 7: Series Circuit Controller/Fixture Architecture

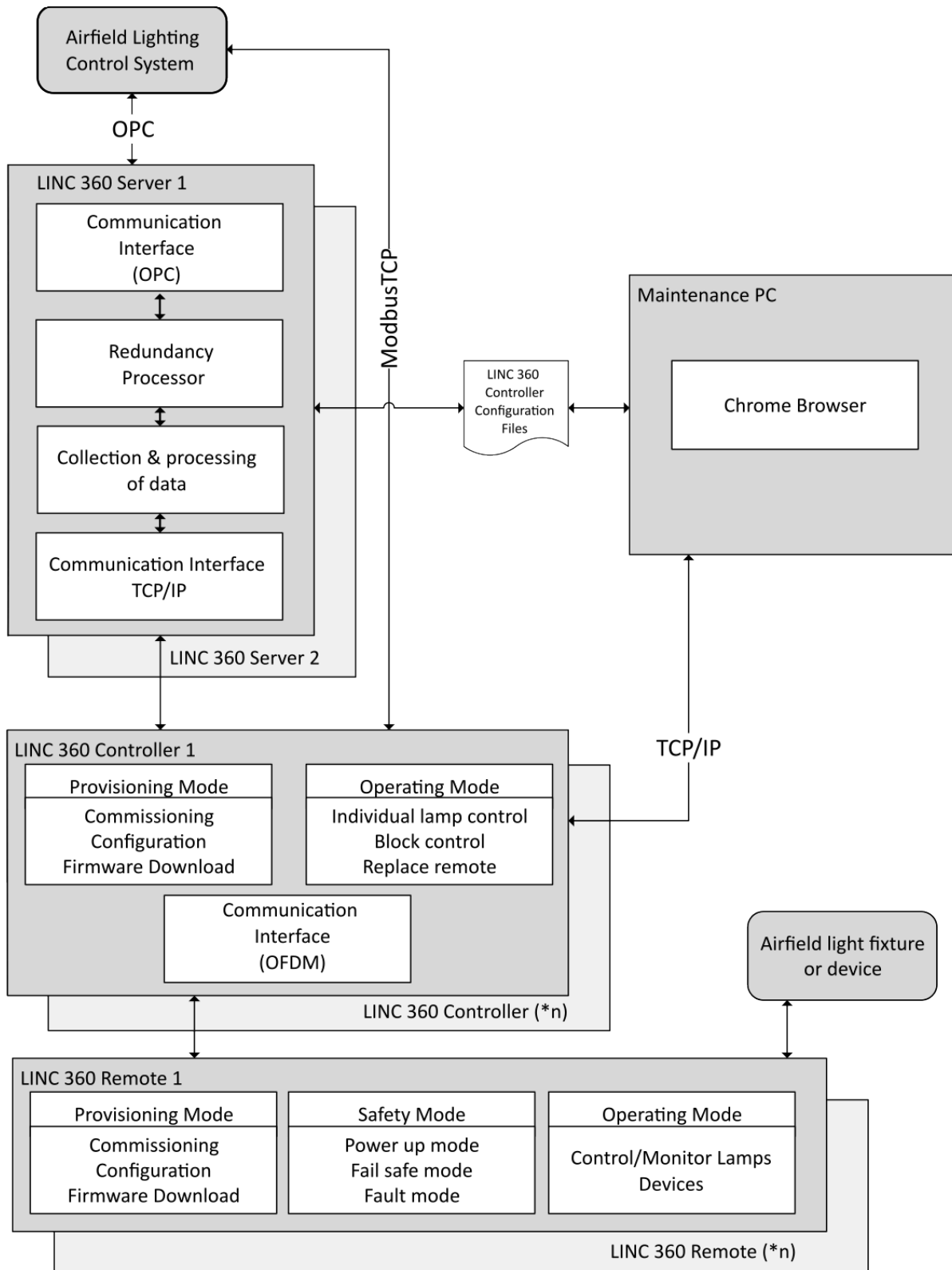

3.0 Installation

Installation is identical for all LINC 360 Remote versions.

Figure 8: Diagram of LINC 360 Installation in Series Circuit

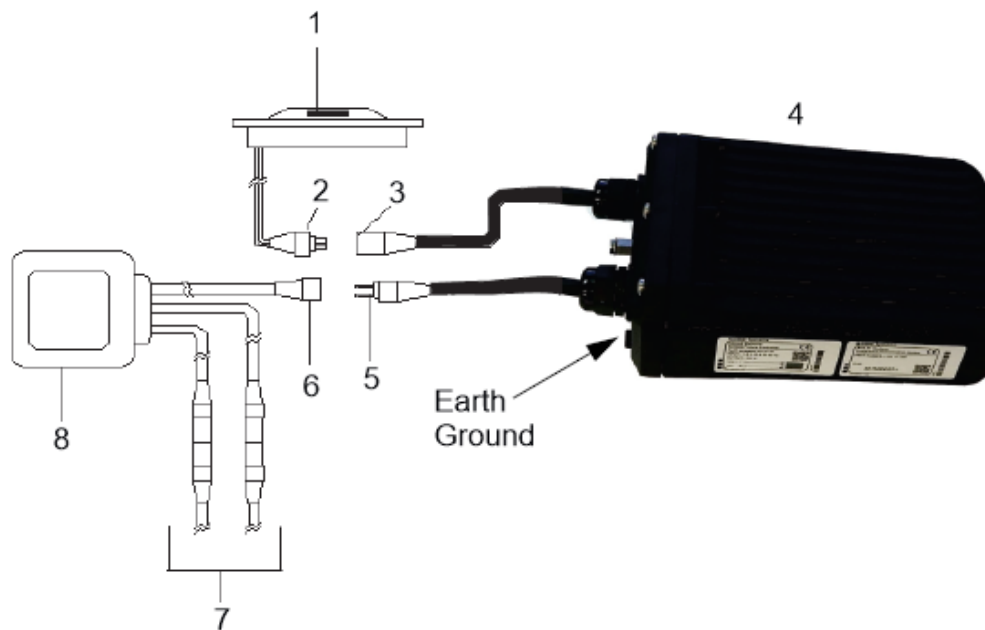

1. Light Fixture	5. Remote Input Plug (TRANSFORMER)
2. Light Fixture Plug	6. Transformer Secondary Receptacle
3. Remote Output Receptacle (LAMP)	7. Primary Series Circuit
4. Remote	8. L-830/L-831 Isolation Transformer

3.1 Installation in a Transformer Pit

The orientation required for installation is indicated by the labeling on the nameplate.

This ensures optimum heat dissipation through the housing. If the device is installed by suspension, free air circulation must be provided for the LINC 360 Remote.



Note

If several LINC 360 Remotes are installed in a single pit, they should be spaced with a distance of at least 2-inch (50mm) from each other and from the series transformers to have optimum communication signal separation. Because the communication signal is coupled magnetically, the distance between the transformers should also not be less than 2-inch (50mm).

Minimum distance between remote cable feed-through and pit walls is 2-inch (50 mm).

Figure 9: Remote Max. Bending Radius



3.2 Connection to the Series Transformer and the Light Fitting(s)

The 2-pin plug on cable X1 is connected to the socket for the secondary circuit of the series transformer. The light(s) is/are connected to the 2-pin socket(s) of the cable(s) X3 (and X4 for the LINC 360 dual Remote).

All plug connections must be sealed with self-bonding insulation tape or using "heat shrink" sleeves.

To improve water tightness, an optional watertight heat shrink sleeve can be installed at the junction of the plug and receptacle: (see [Figure 10](#))

Figure 10: Connection to Series Transformer and Light Fitting

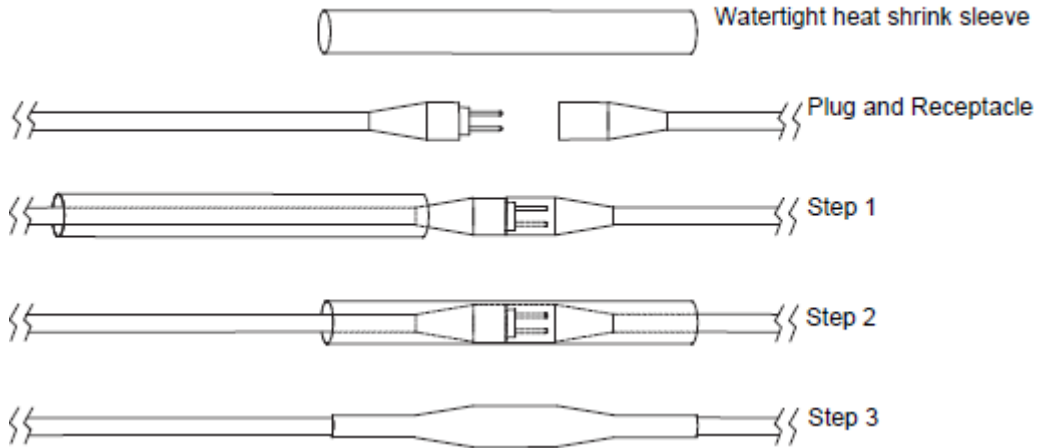

1. Place the heat shrink sleeve over the light inset plug wire.
2. Connect the inset light plug to the Remote receptacle designated CHANNEL A (and CHANNEL B if used).
3. Pull the heat shrink sleeve over the plug-to-receptacle connection. Heats shrink the sleeve.
Repeat steps 1 through 3 for the Remote plug designated TRANSFORMER and the transformer secondary receptacle.

3.3 Utility Device Enclosure Wiring Diagram

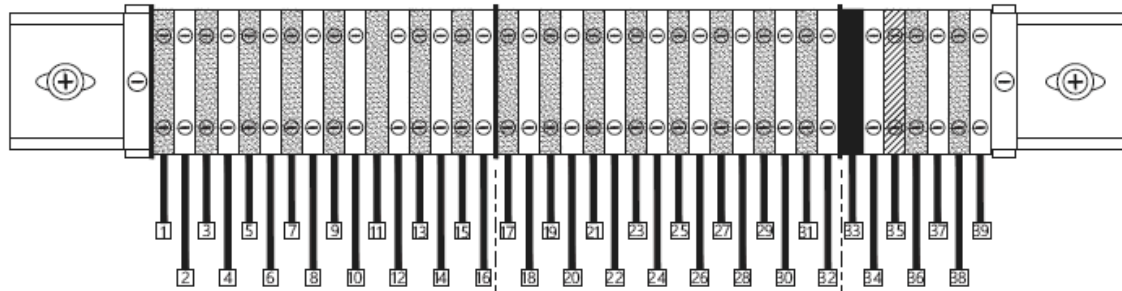

8 CHANNELS REMOTE INPUT
ACCEPTS 5-30VDC

8 CHANNELS DISCRETE OUTPUT
50VDC @ 1A
240VAC @ 0.25A
120VAC @ 0.5A

8 Channel Input

Wiring Table

Block #	Name	AWG	Color
1	Input 1 Hi	20	Blue
2	Input 1 Lo	20	White
3	Input 2 Hi	20	Blue
4	Input 2 Lo	20	White
5	Input 3 Hi	20	Blue
6	Input 3 Lo	20	White
7	Input 4 Hi	20	Blue
8	Input 4 Lo	20	White
9	Input 5 Hi	20	Blue
10	Input 5 Lo	20	White
11	Input 6 Hi	20	Blue
12	Input 6 Lo	20	White
13	Input 7 Hi	20	Blue
14	Input 7 Lo	20	White
15	Input 8 Hi	20	Blue
16	Input 8 Lo	20	White

8 Channel Output

Wiring Table

Block #	Name	AWG	Color
17	Relay 1 NO	20	Blue
18	Relay 1 COM	20	White
19	Relay 2 NO	20	Blue
20	Relay 2 COM	20	White
21	Relay 3 NO	20	Blue
22	Relay 3 COM	20	White
23	Relay 4 NO	20	Blue
24	Relay 4 COM	20	White
25	Relay 5 NO	20	Blue
26	Relay 5 COM	20	White
27	Relay 6 NO	20	Blue
28	Relay 6 COM	20	White
29	Relay 7 NO	20	Blue
30	Relay 7 COM	20	White
31	Relay 8 NO	20	Blue
32	Relay 8 COM	20	White

Power Connection

Wiring Table

Block #	Name	AWG	Color
33	ISO TX input		Black
34	ISO TX input		White
35	Ground Connection	6	GRN/YLW
36	13.5 VDC (+) @ 0.9A	20	White
37	13.5 VDC (-) @ 0.9A	20	Blue
38	25.5 VDC (+) @ 0.5A	20	White
39	25.5 VDC (-) @ 0.5A	20	Blue

3.4 Earth Grounding

To protect it against a surge generated by lightning, each LINC 360 Remote should be provided with a separate, low induction and low resistance ground connection via the ground screw. The ground cable must be connected to the ground screw by means of a suitable cable lug. The cross-sectional area of the cable should be at least AWG 8 (6 mm²) with a maximum cable length of 36- inch (1m).

If the isolation value of the earth ground is bad, it is better NOT to connect the remote to earth ground (see Figure 11).

The options below are meant as a guidance to optimize powerline communication and personal safety. Some earthing options can have an adverse effect and careful consideration is needed to achieve the best results.

Figure 11: Connection to a Series Circuit Isolation Transformer and Light Fitting

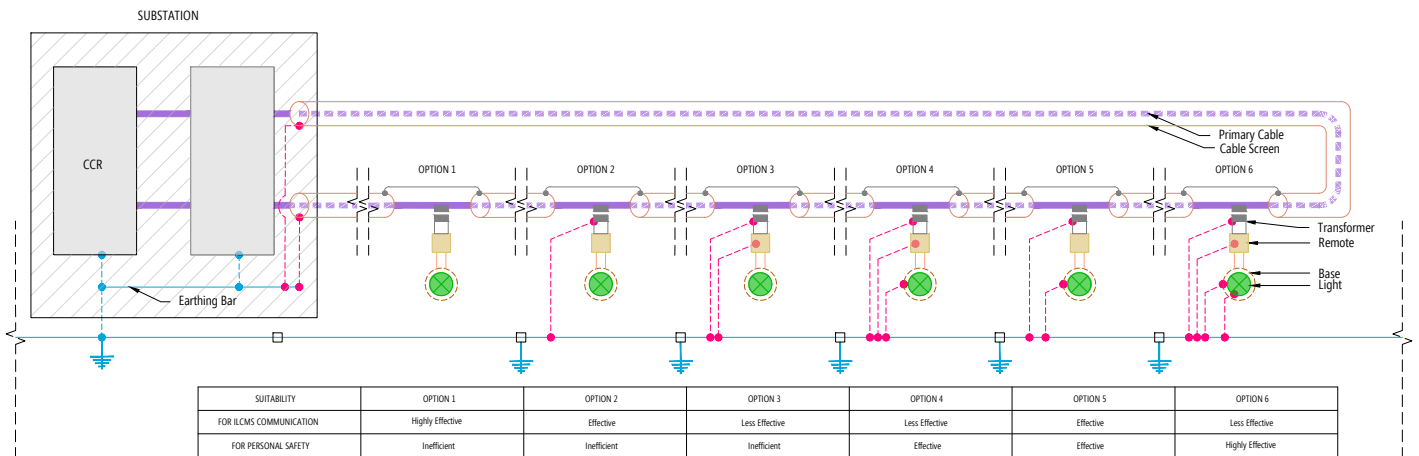

3.5 Safety Instructions



DANGER

READ THIS ENTIRE MANUAL PRIOR TO STARTING ANY WORK.

WORK ON 120/240 V POWER SUPPLY SYSTEMS OR THE SERIES CIRCUIT MUST ONLY BE CARRIED OUT BY TRAINED, QUALIFIED STAFF. THE CURRENTLY APPLICABLE REGULATIONS ACCORDING TO INTERNATIONAL STANDARDS MUST BE FOLLOWED. ALSO SEE THE "SAFETY" SECTION.



Note

The LINC 360 Remote is maintenance free.

The LINC 360 Remote must never be opened, otherwise warranty will be void.

3.6 Replacing a LINC 360 Remote

1. In each case, inspect the technical condition of the LINC 360 Remote which has to be removed or replaced, or the LINC 360 Remote which is to be installed as a replacement device.
2. If the old Remote is still communicating with the Controller (can be verified with the LINC 360 Configuration software), it is recommended to logout this remote prior to removal.
Follow the "Logout procedure" procedure as described in "96A0430 LINC 360 Configuration Software User Manual".
If the remote is completely dead, Step 2 is not applicable.
3. Switch off and disconnect the associated series circuit from the incoming power by removing the fuses of the Constant Current Regulator (CCR).
4. Pull out the cut-out for the series circuit, if possible ground the series circuit and wait about 5 minutes until the circuit is fully discharged.

5. Removing a LINC 360 Remote: first, separate the series circuit connections X3 and X1 and, in the case of the LINC 360 dual Remote, X4 at the cable plug connections.
Then, open the ground connection X2 by unscrewing the earth ground screw.
6. Installing a LINC 360 Remote: install the new LINC 360 Remote according to the "[Installation](#)".
7. Switch on the associated series circuit and verify if the replaced remote connected lamp(s) are functioning (for RGL Remotes: blinking).
8. Follow the "change Remote" procedure as described in "96A0430 LINC 360 Configuration Software - User Manual" to make the replaced remote operational.

4.0 Modes of Operation of an LINC 360 Remote

4.1 Frequency Scan

Initial State on a new remote from the factory.

State on delivery

On delivery, each new LINC 360 Remote that has not yet been logged on with a LINC 360 Controller is in “frequency scan mode”. For power-up mode (“On”), fail-safe mode (“On”) and Delayed Start/Stop (“Off”) it uses the factory settings, which are given here in brackets (default values). RGL//Wig-wag Remotes are pre-configured with “Blink” for power-up and fail-safe mode.

Base state

A LINC 360 Remote that has been logged off from a circuit also reverts to frequency scan mode. However, for power-up mode, fail-safe mode and Delayed Start/Stop it uses the most recent settings received from the LINC 360 Controller (most recent configuration). In frequency scan mode, a LINC 360 Remote, when it is installed in a series circuit and the latter is turned on, searches on all frequency bands for a Controller telegram containing its serial number. If this search is successful, the LINC 360 Remote logs on to the corresponding LINC 360 Controller. When an LINC 360 Remote is logged off from a circuit, it reverts to base state.

4.2 Operating Mode

After successfully logging on, a LINC 360 Remote automatically switches to “operating mode” (normal operation) and receives its configuration parameters from the LINC 360 Controller. All parameters are stored firmly in the LINC 360 Remote. In operating mode, all lights connected to the LINC 360 Remotes can be switched independently of each other via single or block commands (i.e. a command switches a predefined group of lights). The switch commands can be “On”, “Off” or “Blink”.

When a LINC 360 Remote receives a switch command it returns the message “switch command executed” (block command) or “switch command received” (single command). However, the real status of the lights is only determined at the next status polling by the LINC 360 Controller. In the LINC 360 Remote, each switching operation for the light is carried out first via an electronic switch and then via a relay (“blink” mode is established with electronic switch only).

Each LINC 360 Remote monitors the status of the lights connected to it (maximum of two lights). The monitoring takes place when the light is switched on by default. Whether the lamp should be monitored in the “Off” state too, is configurable. Once a lamp failure has been detected (“Open”), the light is no longer monitored during this operation period and switch commands for this light are ignored. It will not be checked again until the circuit has been switched off and on again or after the reception of a reset command (software function) from the LINC 360 PC.

4.2.1 Self-test Mode

After the series circuit has been switched on, each LINC 360 Remote runs a self-test. If an error is detected through this test, the LINC 360 Remote switches to error mode. This means that communication with a LINC 360 Controller is not possible.

4.3 Switch Status of the Connected Lights

One light can be connected to each LINC 360 single channel Remote, and up to two lights (“A” and “B”) can be connected to each LINC 360 dual channel Remote. A light can assume the following types of status:

- “Off” (light is switched off and not burning).
- “On” (light is switched on and the electric circuit is closed).
- “Open” (light is switched on but the electric circuit is not closed, i.e. the light filament is broken or the light is not connected).
- “Blink” (light flashing; no information as to whether the light is “On” or “Off” at the time of polling).

On the Graphical User Interface (GUI), the status of each light is indicated by the terms given in quotation marks.

4.4 Switch Status under Special Circumstances

With the help of the LINC 360 PC software, the user has to configure each LINC 360 Remote of a circuit to which the Remote shall switch its connected lights:

- When the series circuit is powered up (power-up mode),

- When the communication between the LINC 360 PC and the LINC 360 Controller or between the LINC 360 Controller and the LINC 360 Remote is interrupted (fail-safe mode),
- And if there is to be a Delayed Start/Stop or not (when several lights are switched simultaneously by a block command).

4.4.1 Power-up Mode

The “power-up mode” defines to which status the LINC 360 Remotes should switch their lights directly after power-up of the series circuit. The parameters of the following types of switch status can be set via the LINC 360 PC:

- “On”.
- “Off”.
- “Blink” (flashing).
- “Last Commanded State” (maintain the last operating status).

This mode ends after a switch command from the LINC 360 Controller has been received.

4.4.2 Fail-safe Mode

As soon as the LINC 360 Remote detects a failure of the communication with its LINC 360 Controller or receives a failsafe telegram from it, it switches the connected light(s) into a predefined status. This status can be parameterized via the LINC 360 PC software as follows:

- “On”.
- “Off”.
- “Blink” (flashing).
- “Last Commanded State” (maintain the last operating status).

The duration of the interval before a communication problem is identified can be configured via the LINC 360 PC software as well. The failsafe mode is not exited automatically after communication has been restored but only after the LINC 360 Remote has received a switch command from the LINC 360 Controller.

4.4.3 Delayed Start/Stop

When switching several lights via a block command, the lights can be controlled using a defined delay (ms), which can be configured. This setting ensures constant current regulator stability in case of large load fluctuations.

4.5 Spreadsheet

A proper accounting of installed remotes and the fixture identifier to which they are installed must be maintained during the installation of the remotes. This table will later on be used to build the ALCMS database. See [Figure 12](#).

Figure 12: Spreadsheet Example

RELIANCE IL Circuit and Remote information sheet for the installer							
Circuit information				Totals (calculated)			
Substation Name:	26L-			Single remotes:		2	
Circuit Name:	TC1-			Dual remotes:		0	
Circuit Length (approx.):	5						
Number of light fixtures:	105						
Number of remotes:	105						
Remote information (* = required)				Channel A		Channel B (only if dual remote)	
Remote Name	Serial number*	Pit Name/Nr	Transfo Type	Light Reference*	Light Fix. Type	Light Reference*	Light Fix. Type
26L-TC1-A7-TC1-7	900101-A7-		RST-100W	TC1-7	FTS-2-045-GG		
26L-TC1-A7-TC1-9	900102-A7-		RST-100W	TC1-9	FTS-2-045-GG		

4.5.1 A sample spreadsheet would contain:

- Vault/substation name: the official name of the vault/substation were the circuit is powered.
- Circuit name: the local name of the circuit (like TC3).
- Circuit length: the approximate length of the circuit (in kilometers).
- Total number of light fixtures: for reference only (not required).
- Number of Remotes: the total number of LINC 360 Remotes on this circuit.
- Remote name: is automatically generated, but may be altered to serve your own needs. Max. 50 characters are allowed. Remember that this will be your only lead to identify and locate lights and remotes out of the LINC 360system.
- Serial number: is unique for every LINC 360 Remote and is required to fill-in.
- Pit Name/Nr: for your own reference only.
- Transfo type: (transformer type) only for your reference.
- Light reference: unique identifier for the connected light fixture on the airfield (see AutoCAD drawing).
- Light Fixture Type: for your own reference only.
- If the Remote is a Dual type: reference must be filled in for Channel B also, even if the light fixture is the same as for Channel A (one fixture with 2 lamps).

Underlined information is mandatory and the absolute minimum required data.

5.0 Parts

Table 4: Ordering Code: Controllers

Description	Part No.
LINC 360 Controller, 19" Rack Mount, EU plug	LINCC00000000101
LINC 360 Controller, Wall Mount, Door Open Left (EU)	LINCC00000000201
LINC 360 Controller, Wall Mount, Door Open Right (EU)	LINCC00000000301
LINC 360 Controller, 19" Rack Mount, US plug	LINCC00000000111
LINC 360 Controller, Wall Mount, Door Open Left (US)	LINCC00000000211
LINC 360 Controller, Wall Mount, Door Open Right (US)	LINCC00000000311
LINC 360 Controller, 19" Rack Mount, UK plug	LINCC00000000121
LINC 360 Controller, Wall Mount, Door Open Left (UK)	LINCC00000000221
LINC 360 Controller, Wall Mount, Door Open Right (UK)	LINCC00000000321
LINC 360 Controller, 19" Compact (no flanges)	LINCC00000000501

Table 5: Ordering Code: Remotes

Description	Part No.
LINC 360 Single Channel Remote, FAA Style 7	AGC4170
LINC 360 Single Channel Remote, FAA Style 8	AGC4180
LINC 360 Single Channel Remote, FAA Style 7, Initial Flash Off	AGC4270
LINC 360 Single Channel Remote, FAA Style 7, Initial Flash On	AGC4370
LINC 360 Dual Channel Remote, FAA Style 7	AGC5170
LINC 360 Dual Channel Remote, FAA Style 7, Channel A Initial Flash On, Channel B Initial Flash Off	AGC5470
LINC 360 Utility Device (Above Ground Installation only)	AGC6110
LINC 360 Power Remote 13.5 Vdc	LINCP00000130001

5.1 Spare Components

Table 6: Ordering Code: Spare Parts

Description	Part No.
GB Industrial Grade Flash Card with Software loaded	AK00048-000-01
LINC 360 Controller Fan Assembly (usb versions with 4-wires)	AS00062-000-01
LINC 360 Controller Touchscreen	EB00274-000-01
Low-voltage PCB Assembly	AS00180-000-01
High-voltage PCB Assembly	44A7379-1
LINC 360/DPS Controller Power Supply	97A0037
LINC 360 Controller Control Module 19" Rack version	SP.AS00182-100-01
LINC 360 Controller Control Module Wall-mount version	SP.AS00182-200-01
DPS Controller Control Module	SP.AS00182-300-01

Appendix A: SUPPORT

Our experienced engineers are available for support and service at all times, 24 hour/7 days a week. They are part of a dynamic organization making sure the entire ADB SAFEGATE is committed to minimal disturbance for airport operations.

ADB SAFEGATE Support

Technical Support – Global

Customers in Europe, the Middle East, Africa or Asia Pacific are more than welcome to our portal for technical support. Trained in all areas of system issues, troubleshooting, quality control and technical assistance, our highly experienced Technical support specialists are available 24 hours a day, seven days a week to provide assistance over the phone. In the Americas, we also offer live technical support.

Live Technical Support – Americas

If at any time you have a question or concern about your product, contact ADB SAFEGATE's US-based technical support specialists, available 24 hours a day, seven days a week, to assist you via phone.

ADB SAFEGATE Americas Technical Service & Support (US & Canada) :+1-800-545-4157

ADB SAFEGATE Americas Technical Service & Support (Canada): +1-905-631-1597

ADB SAFEGATE Americas Technical Service & Support (International): +1-614-861-1304

We can also be reached via email during regular business hours:

Airfield and Gate: techservice.us@adbsafegate.com

Gate: gateservice.us@adbsafegate.com

We look forward to working with you!

Before You Call

When you have an airfield lighting or system control system problem, prior to calling, please ensure the following:

- Review the product's manual and troubleshooting guide.
- Be located with the product ready to troubleshoot.
- Have all necessary information available: airport code/company name, customer id number, contact phone number/email address, product/part number.
- Have a True RMS meter available and any other necessary tools.

When calling about an issue with Safedock A-VDGS, we can serve you better if you collect the following information before you call:

- Relevant information regarding the issue you are calling about, such as gate number, flight number, aircraft type and time of the event.
- What, if any, actions have been taken to resolve the issue prior to the call.
- If available, provide a CCTV recording of the incident to aid in aligning the information from the Safedock log file.



Note

For more information, see www.adbsafegate.com, contact ADB SAFEGATE Support via email at support@adbsafegate.com or Europe: +32 2 722 17 11

Americas: +1 614 861 1304. Press 3 for technical service or press 4 for sales support.

China: +86 (10) 8476 0106

Middle East and Africa: +971 4 452 7575

A.1 ADB SAFEGATE Website

The ADB SAFEGATE website, www.adbsafegate.com, offers information regarding our airport solutions, products, company, news, links, downloads, references, contacts and more.

A.2 Recycling

A.2.1 Local Authority Recycling

The disposal of ADB SAFEGATE products is to be made at an applicable collection point for the recycling of electrical and electronic equipment. The correct disposal of equipment prevents any potential negative consequences for the environment and human health, which could otherwise be caused by inappropriate waste handling. The recycling of materials helps to conserve natural resources. For more detailed information about recycling of products, contact your local authority city office.

A.2.2 ADB SAFEGATE Recycling

ADB SAFEGATE is fully committed to environmentally-conscious manufacturing with strict monitoring of our own processes as well as supplier components and sub-contractor operations. ADB SAFEGATE offers a recycling program for our products to all customers worldwide, whether or not the products were sold within the EU.

ADB SAFEGATE products and/or specific electrical and electronic component parts which are fully removed/separated from any customer equipment and returned will be accepted for our recycling program.

All items returned must be clearly labeled as follows:

- For RoHS/WEEE Recycling
- Sender contact information (Name, Business Address, Phone number).
- Main Unit Serial Number.

ADB SAFEGATE will continue to monitor and update according for any future requirements for EU directives as and when EU member states implement new regulations and or amendments. It is our aim to maintain our compliance plan and assist our customers.

Company Addresses

ADB SAFEGATE, Belgium	ADB SAFEGATE BV Leuvensesteenweg 585 B-1930 Zaventem Belgium
Contact:	
Tel.: +32 2 722 17 11	Email: marketing@adbsafegate.com
Fax: +32 2 722 17 64	Internet: www.adbsafegate.com
ADB SAFEGATE, Americas	ADB SAFEGATE Americas, LLC 700 Science Blvd Gahanna, OH 43230 USA
Contact:	
Tel.: +1 (614) 861 1304	Email: sales.us@adbsafegate.com
Fax: +1 (614) 864 2069	Internet: www.adbsafegate.com
ADB SAFEGATE, Sweden	ADB SAFEGATE Sweden AB Djurhagegatan 19 SE-213 76 Malmö Sweden
Contact:	
Tel.: +46 (0)40 699 17 00	Email: marketing@adbsafegate.com
Fax: +46 (0)40 699 17 30	Internet: www.adbsafegate.com
ADB SAFEGATE, China	ADB SAFEGATE Airfield Technologies Ltd. China Unit 603, D Block, CAMIC International Convention Center, No 3, Hua Jia Di East road, ChaoYang district, Beijing 100102 P.R. China
Contact:	
Tel.: +86 (10) 8476 0106	Email: china@safegate.com
Fax: +86 (10) 8476 0090	Internet: www.adbsafegate.com
ADB SAFEGATE, Germany	ADB SAFEGATE Germany GmbH Konrad-Zuse-Ring 6, D-68163 Mannheim Germany
Contact:	
Tel.: +49 (621) 87 55 76-0	Email: marketing@adbsafegate.com
Fax: +49 (621) 87 55 76-55	Internet: www.adbsafegate.com

WWW.ADBSAFEGATE.COM

Empowering the Airside **Evolution**

SMARTER. BETTER. **NOW.**



Copyright ©2017—2025 ADB SAFEGATE, All Rights Reserved