

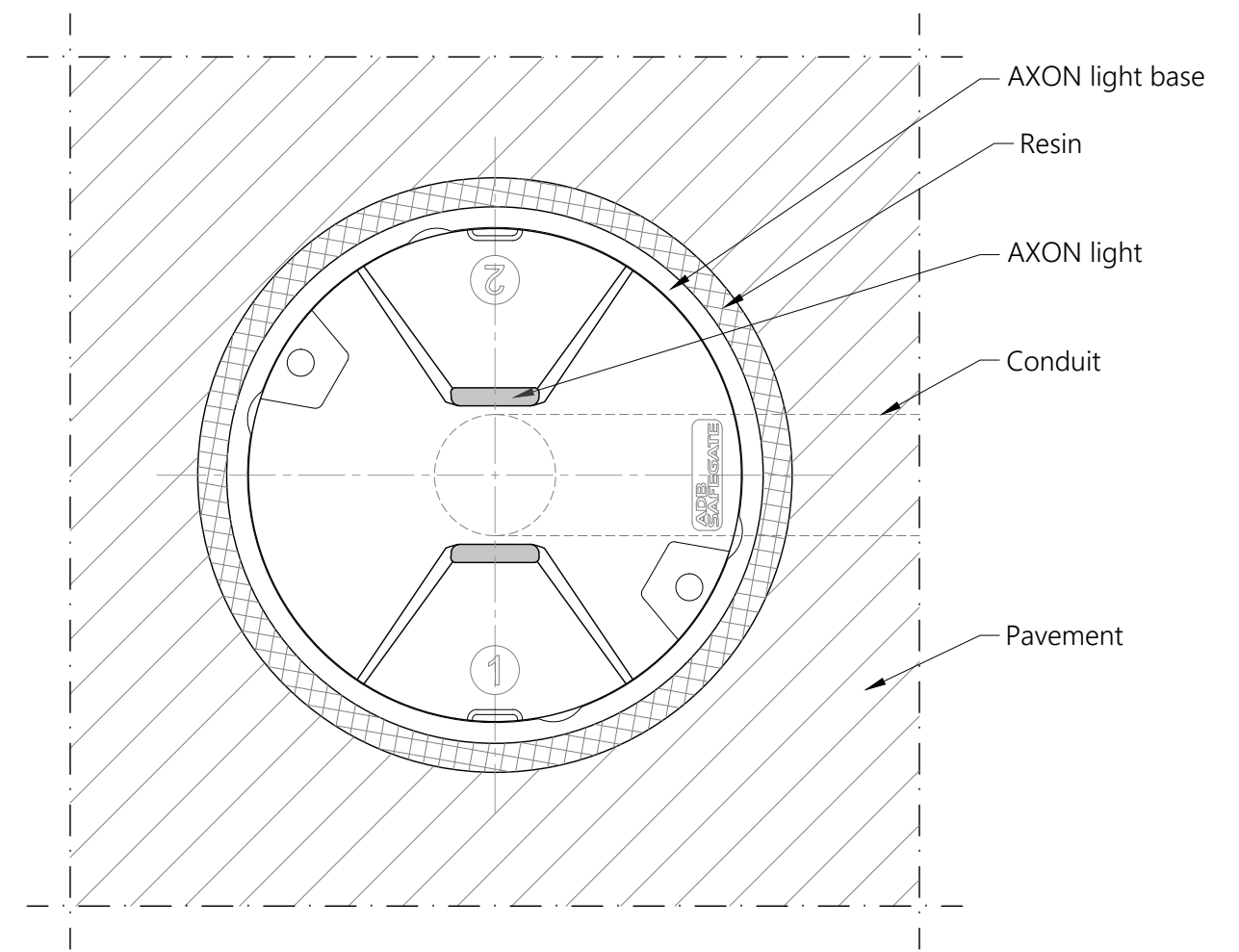

SECTION  
 AXON INSET 8" BIDIRECTIONAL LIGHT  
 Scale 1/4



TOP VIEW  
 AXON INSET 8" BIDIRECTIONAL LIGHT  
 Scale 1/3

- NOTES:
1. This drawing shows general installation details related to ADB Safegate products and is not for construction. The designer must verify compliance of design with local standards and varying characteristics for each unique airfield project.
  2. Pavement types and dimensions shown are only indicative. Installation details may vary depending on project specific pavement types and dimensions.
  3. Please refer to product installation manual for installation process details.

	AXON LIGHT 8 inch	SCALE: AS SHOWN	UNIT: mm
	INSET BIDIRECTIONAL	DRAWN BY: EK	CHECKED BY: TH
	TYPICAL INSTALLATION DETAILS	DATE: 02/02/2024	SHEET: 1-2
ADBSG_A_AGL_AXON-I_8in_Bi_01			

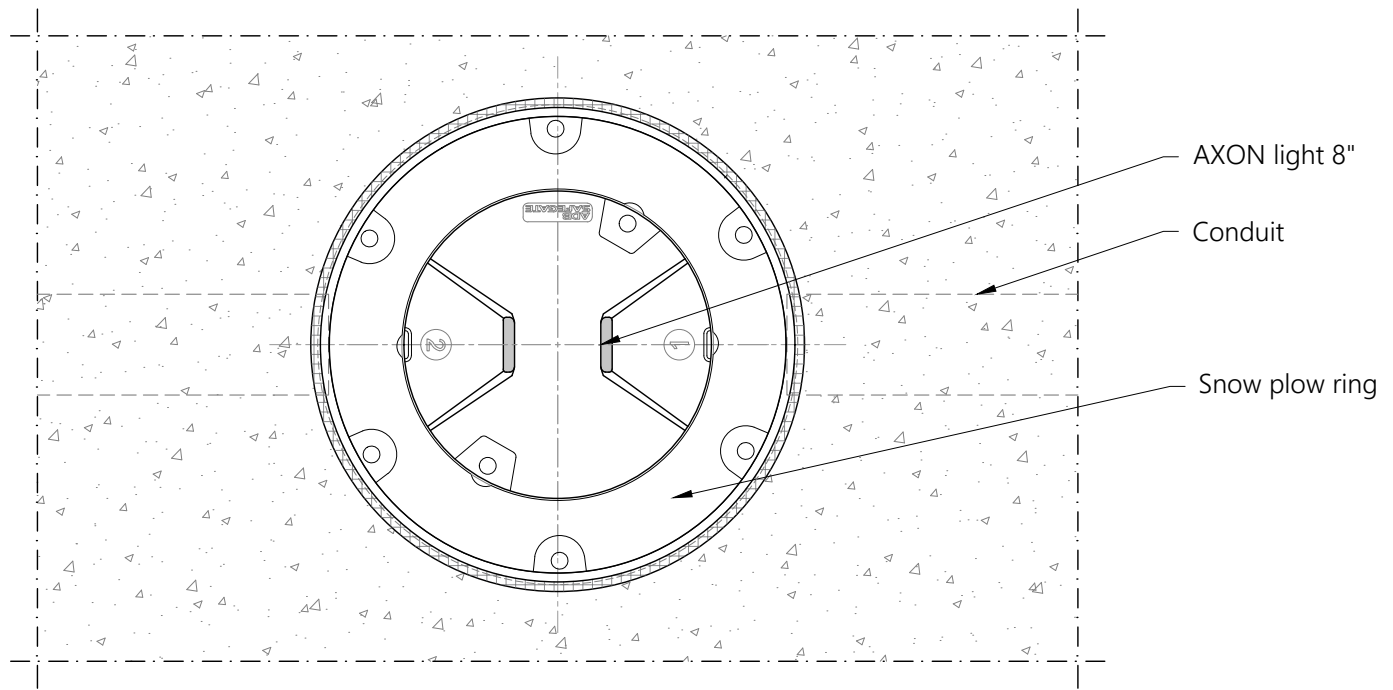

TOP VIEW  
 AXON INSET 8" BIDIRECTIONAL LIGHT  
 Scale 1/5

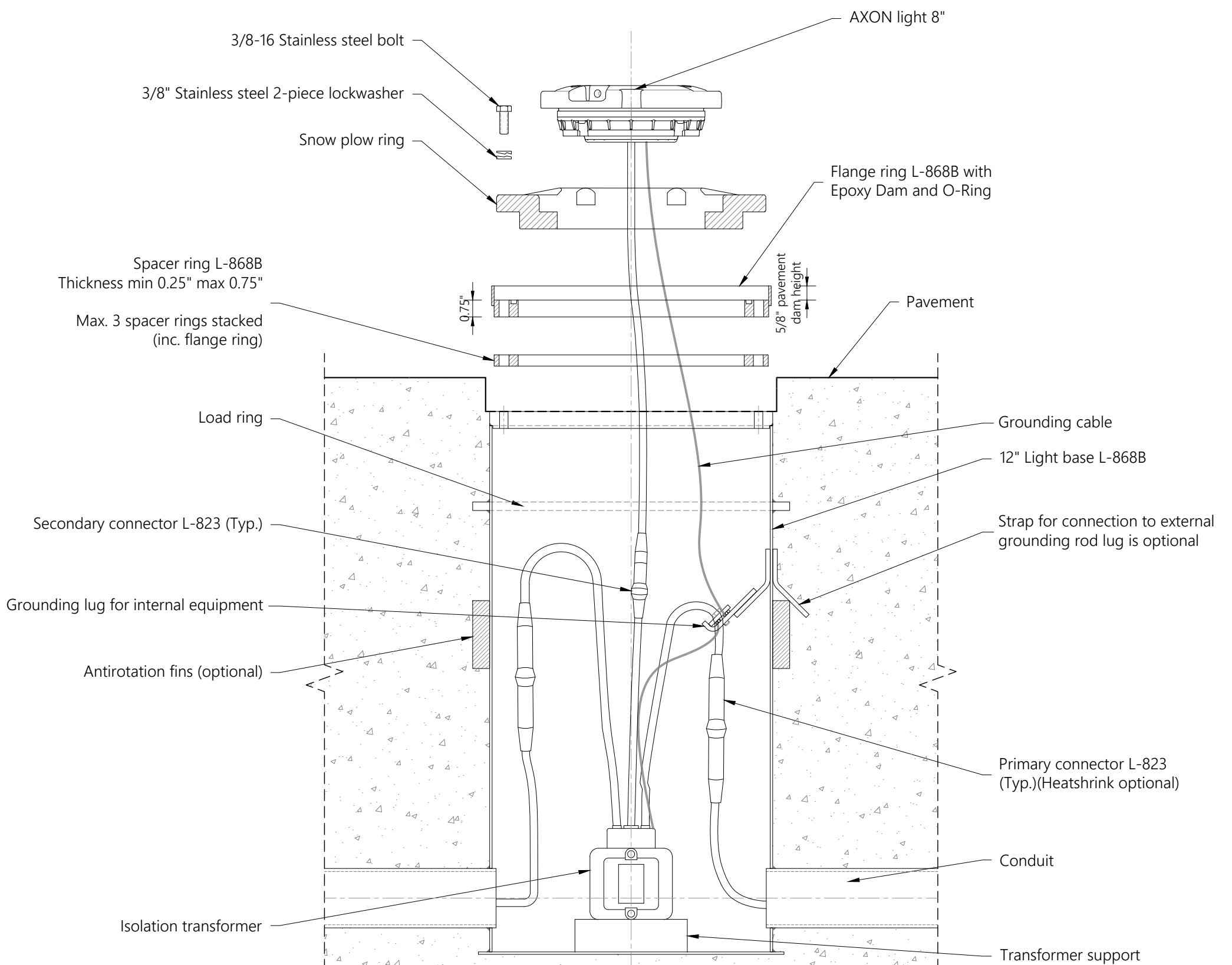

1 PIECE L-868B BASE INSTALLATION  
 AXON INSET 8" BIDIRECTIONAL LIGHT  
 Scale 1/5

NOTES:

1. This drawing shows general installation details related to ADB Safegate products and is not for construction. The designer must verify compliance of design with local standards and varying characteristics for each unique airfield project.
2. Pavement types and dimensions shown are only indicative. Installation details may vary depending on project specific pavement types and dimensions.
3. Please refer to product installation manual for installation process details.



AXON LIGHT  
 8 inch  
 INSET BIDIRECTIONAL  
 TYPICAL INSTALLATION DETAILS

SCALE: AS SHOWN  
 DRAWN BY: EK  
 DATE: 02/02/2024

UNIT: mm  
 CHECKED BY: TH  
 SHEET: 2-2

ADBSG\_A\_AGL\_AXON-I\_8in\_Bi\_01