



RELIANCE L-861T Elevated Taxiway Edge LED (ETES)Light

User Manual

96A0321, Rev. 1.1.0, 2025-Dec-01

ADB 
SAFEGATE

A.0 Disclaimer / Standard Warranty

CE certification

The equipment listed as CE certified means that the product complies with the essential requirements concerning safety and hygiene. The European directives that have been taken into consideration in the design are available on written request to ADB SAFEGATE.

ETL certification

The equipment listed as ETL certified means that the product complies with the essential requirements concerning safety and C22.2 No.180:13 (R2018) regulations. The CSA directives that have been taken into consideration in the design are available on written request to ADB SAFEGATE.

All Products Guarantee

ADB SAFEGATE will correct by repair or replacement per the applicable guarantee below, at its option, equipment or parts which fail because of mechanical, electrical or physical defects, provided that the goods have been properly handled and stored prior to installation, properly installed and properly operated after installation, and provided further that Buyer gives ADB SAFEGATE written notice of such defects after delivery of the goods to Buyer. Refer to the Safety section for more information on Material Handling Precautions and Storage precautions that must be followed.

ADB SAFEGATE reserves the right to examine goods upon which a claim is made. Said goods must be presented in the same condition as when the defect therein was discovered. ADB SAFEGATE further reserves the right to require the return of such goods to establish any claim.

ADB SAFEGATE's obligation under this guarantee is limited to making repair or replacement within a reasonable time after receipt of such written notice and does not include any other costs such as the cost of removal of defective part, installation of repaired product, labor or consequential damages of any kind, the exclusive remedy being to require such new parts to be furnished.

ADB SAFEGATE's liability under no circumstances will exceed the contract price of goods claimed to be defective. Any returns under this guarantee are to be on a transportation charges prepaid basis. For products not manufactured by, but sold by ADB SAFEGATE, warranty is limited to that extended by the original manufacturer. This is ADB SAFEGATE's sole guarantee and warranty with respect to the goods; there are no express warranties or warranties of fitness for any particular purpose or any implied warranties of fitness for any particular purpose or any implied warranties other than those made expressly herein. All such warranties being expressly disclaimed.

Standard Products Guarantee

Products manufactured by ADB SAFEGATE are guaranteed against mechanical, electrical, and physical defects (excluding lamps) which may occur during proper and normal use for a period of two years from the date of ex-works delivery, and are guaranteed to be merchantable and fit for the ordinary purposes for which such products are made.



Note

See your applicable sales agreement for a complete warranty description.

Replaced or repaired equipment under warranty falls into the warranty of the original delivery. No new warranty period is started for these replaced or repaired products.

FAA Certified products manufactured by ADB SAFEGATE

ADB SAFEGATE L858 Airfield Guidance Signs are warranted against mechanical and physical defects in design or manufacture for a period of 2 years from date of installation, per FAA AC 150/5345-44 (applicable edition).

ADB SAFEGATE LED products (with the exception of obstruction lighting) are warranted against electrical defects in design or manufacture of the LED or LED specific circuitry for a period of 4 years from date of installation, per FAA EB67 (applicable edition). These FAA certified constant current (series) powered LED products must be installed, interfaced and powered with and through products certified under the FAA Airfield Lighting Equipment Program (ALECP) to be included in this 4 (four) year warranty. This includes, but is not limited to, interface with products such as Base Cans, Isolation Transformers, Connectors, Wiring, and Constant Current Regulators.



Note

See your sales order contract for a complete warranty description.

Replaced or repaired equipment under warranty falls into the warranty of the original delivery. No new warranty period is started for these replaced or repaired products.

Liability



WARNING

Use of the equipment in ways other than described in the catalog leaflet and the manual may result in personal injury, death, or property and equipment damage. Use this equipment only as described in the manual.

ADB SAFEGATE cannot be held responsible for injuries or damages resulting from non-standard, unintended uses of its equipment. The equipment is designed and intended only for the purpose described in the manual. Uses not described in the manual are considered unintended uses and may result in serious personal injury, death or property damage.

Unintended uses, includes the following actions:

- Making changes to equipment that have not been recommended or described in this manual or using parts that are not genuine ADB SAFEGATE replacement parts or accessories.
- Failing to make sure that auxiliary equipment complies with approval agency requirements, local codes, and all applicable safety standards if not in contradiction with the general rules.
- Using materials or auxiliary equipment that are inappropriate or incompatible with your ADB SAFEGATE equipment.
- Allowing unskilled personnel to perform any task on or with the equipment.

Copyright Statement

This manual or parts thereof may not be reproduced, stored in a retrieval system, or transmitted, in any form or by any means, electronic, mechanical, photocopying, recording, nor otherwise, without the author's prior written consent.

This manual could contain technical inaccuracies or typographical errors. The author reserves the right to revise this manual from time to time in the contents thereof without obligation of the author to notify any person of such revision or change. Details and values given in this manual are average values and have been compiled with care. They are not binding, however, and the author disclaims any liability for damages or detriments suffered as a result of reliance on the information given herein or the use of products, processes or equipment to which this manual refers. No warranty is made that the use of the information or of the products, processes or equipment to which this manual refers will not infringe any third party's patents or rights. The information given does not release the buyer from making their own experiments and tests.

Table of Contents

1.0 Safety	1
1.1 Safety Messages.....	1
1.1.1 Introduction to Safety.....	2
1.1.2 Intended Use.....	2
1.1.3 Material Handling Precautions : Storage.....	3
1.1.4 Operation Safety.....	3
1.1.5 Maintenance Safety.....	3
1.1.6 Material Handling Precautions, ESD.....	4
1.1.7 Arc Flash and Electric Shock Hazard.....	4
2.0 RELIANCE L-861T Elevated Taxiway Edge LED (ETES) Light	5
2.1 About this manual.....	5
2.2 How to work with the manual.....	5
3.0 Introduction	7
3.1 Taxiway Edge, L-861T(L).....	7
4.0 Installation	11
4.1 Installation Safety Considerations.....	11
4.2 Introduction.....	11
4.2.1 Unpacking.....	11
4.3 Placement.....	11
4.4 Installation Procedures.....	11
4.4.1 Base Mounting.....	11
4.4.2 Light Base Mounting.....	12
4.4.3 Light Fixture Leveling.....	14
4.4.4 Stake Mounting.....	14
5.0 Maintenance Introduction	17
5.1 Maintenance Schedule.....	17
5.1.1 Assembly Instructions.....	17
6.0 Ordering Code	19
6.1 Ordering Code.....	0
7.0 Troubleshooting	21
7.1 Troubleshooting Procedures.....	21
7.2 Repair.....	21
7.2.1 Access to Internal Components.....	21
7.2.2 LED and Arctic Kit or Electronic Module Replacement.....	22
7.2.3 Cord Set Replacement.....	22
7.2.4 Glassware and Gasket Seal Replacement.....	23
7.2.5 Replacement of Existing Fixture.....	23
8.0 RELIANCE ETES Parts	25
8.1 L-861T Optional Stake Assembly Parts List.....	28
8.2 Optional Parts.....	29
8.3 Retrofit Charts.....	30
8.3.1 LED Replacement Charts.....	31
8.4 Spare Parts.....	33
A.0 SUPPORT	35
A.1 ADB SAFEGATE Website.....	35
A.2 Recycling.....	36
A.2.1 Local Authority Recycling.....	36
A.2.2 ADB SAFEGATE Recycling.....	36

List of Figures

Figure 1: RELIANCE L-861T Elevated Taxiway Edge LED (ETES)	5
Figure 2: ETES L-861T(L) fixture mounted on an L-867B base can	13
Figure 3: ETES L-861T(L) fixture mounted on an L-868B base can	14
Figure 4: Stake Assembly.....	15
Figure 5: RELIANCE ETES Assembly.....	25
Figure 6: L-861T ETES Fixture (part 1 of 2)	26
Figure 7: L-861T ETES Fixture (part 2 of 2)	26
Figure 8: L-861T ETES Fixture and L-861T ETES (without heater)	27
Figure 9: L-861T ETES (with heater).....	28
Figure 10: Stake Assembly.....	29
Figure 11: ETES LED Retro Fit Chart to Rev J and After 1/15/08	30
Figure 12: ETES LED Retro Fit Chart Prior to 1/15/08 Rev J.....	31

List of Tables

Table 1: L-861T Light Fixture Maintenance.....	17
Table 2: Main Components Parts Not Shown List	27
Table 3: ETES Replacement Chart For ETES/XXXX REV J CHANGE.....	31
Table 4: Replacement Kits	32
Table 5: Spare Parts	33

1.0 Safety

Introduction to Safety







This section contains general safety instructions for installing and using ADB SAFEGATE equipment. Some safety instructions may not apply to the equipment in this manual. Task- and equipment-specific warnings are included in other sections of this manual where appropriate.

1.1 Safety Messages

HAZARD Icons used in this manual

For all HAZARD symbols in use, see the Safety section. All symbols must comply with ISO and ANSI standards.

Carefully read and observe all safety instructions in this manual, which alert you to safety hazards and conditions that may result in personal injury, death or property and equipment damage and are accompanied by the symbols shown below.

	<p>WARNING Failure to observe a warning may result in personal injury, death or equipment damage.</p>
	<p>DANGER – Risk of electrical shock or ARC FLASH Disconnect equipment from line voltage. Failure to observe this warning may result in personal injury, death, or equipment damage. ARC Flash may cause blindness, severe burns or death.</p>
	<p>WARNING – Wear personal protective equipment Failure to observe may result in serious injury.</p>
	<p>WARNING – Do not touch Failure to observe this warning may result in personal injury, death, or equipment damage.</p>
	<p>CAUTION Failure to observe a caution may result in equipment damage.</p>
	<p>ELECTROSTATIC SENSITIVE DEVICES This equipment may contain electrostatic devices.</p>

Qualified Personnel

	<p>Important Information</p> <p>The term qualified personnel is defined here as individuals who thoroughly understand the equipment and its safe operation, maintenance and repair. Qualified personnel are physically capable of performing the required tasks, familiar with all relevant safety rules and regulations and have been trained to safely install, operate, maintain and repair the equipment. It is the responsibility of the company operating this equipment to ensure that its personnel meet these requirements.</p> <p>Always use required personal protective equipment (PPE) and follow safe electrical work practice.</p>
---	---

1.1.1 Introduction to Safety



CAUTION

Unsafe Equipment Use

This equipment may contain electrostatic devices, hazardous voltages and sharp edges on components

- Read installation instructions in their entirety before starting installation.
- Become familiar with the general safety instructions in this section of the manual before installing, operating, maintaining or repairing this equipment.
- Read and carefully follow the instructions throughout this manual for performing specific tasks and working with specific equipment.
- Make this manual available to personnel installing, operating, maintaining or repairing this equipment.
- Follow all applicable safety procedures required by your company, industry standards and government or other regulatory agencies.
- Install all electrical connections to local code.
- Use only electrical wire of sufficient gauge and insulation to handle the rated current demand. All wiring must meet local codes.
- Route electrical wiring along a protected path. Make sure they will not be damaged by moving equipment.
- Protect components from damage, wear, and harsh environment conditions.
- Allow ample room for maintenance, panel accessibility, and cover removal.
- Protect equipment with safety devices as specified by applicable safety regulations
- If safety devices must be removed for installation, install them immediately after the work is completed and check them for proper functioning prior to returning power to the circuit.

Failure to follow these instructions can result in serious injury, death or equipment damage

Additional Reference Materials



Important Information

- IEC – International Standards and Conformity Assessment for all electrical, electronic and related technologies.
- IEC 60364 – Electrical Installations in Buildings.
- CSA – C22.2 No.180:13 (R2018), series isolating transformers for airport lighting.
- FAA Advisory: AC 150/5340-26 (current edition), Maintenance of Airport Visual Aid Facilities.
- Maintenance personnel must refer to the maintenance procedure described in the ICAO Airport Services Manual, Part 9.
- ANSI/NFPA 79, Electrical Standards for Metalworking Machine Tools.
- National and local electrical codes and standards.

1.1.2 Intended Use



CAUTION

Use this equipment as intended by the manufacturer

This equipment is designed to perform a specific function, do not use this equipment for other purposes

- Using this equipment in ways other than described in this manual may result in personal injury, death or property and equipment damage. Use this equipment only as described in this manual.

Failure to follow this instruction can result in serious injury or equipment damage

1.1.3 Material Handling Precautions : Storage



CAUTION

Improper Storage

Store this equipment properly

- If equipment is to be stored prior to installation, it must be protected from the weather and kept free of condensation and dust.

Failure to follow this instruction can result in equipment damage

1.1.4 Operation Safety



CAUTION

Improper Operation

Do Not Operate this equipment other than as specified by the manufacturer

- Only qualified personnel, physically capable of operating the equipment and with no impairments in their judgment or reaction times, should operate this equipment.
- Read all system component manuals before operating this equipment. A thorough understanding of system components and their operation will help you operate the system safely and efficiently.
- Before starting this equipment, check all safety interlocks, fire-detection systems, and protective devices such as panels and covers. Make sure all devices are fully functional. Do not operate the system if these devices are not working properly. Do not deactivate or bypass automatic safety interlocks or locked-out electrical disconnects or pneumatic valves.
- Protect equipment with safety devices as specified by applicable safety regulations.
- If safety devices must be removed for installation, install them immediately after the work is completed and check them for proper functioning.
- Route electrical wiring along a protected path. Make sure they will not be damaged by moving equipment.
- Never operate equipment with a known malfunction.
- Do not attempt to operate or service electrical equipment if standing water is present.
- Use this equipment only in the environments for which it is rated. Do not operate this equipment in humid, flammable, or explosive environments unless it has been rated for safe operation in these environments.
- Never touch exposed electrical connections on equipment while the power is ON.

Failure to follow these instructions can result in serious injury, death or equipment damage.

1.1.5 Maintenance Safety



DANGER

ELECTRIC SHOCK HAZARD

THIS EQUIPMENT MAY CONTAIN ELECTROSTATIC DEVICES

- DO NOT OPERATE A SYSTEM THAT CONTAINS MALFUNCTIONING COMPONENTS. IF A COMPONENT MALFUNCTIONS, TURN THE SYSTEM OFF IMMEDIATELY.
- DISCONNECT AND LOCK OUT ELECTRICAL POWER.
- ALLOW ONLY QUALIFIED PERSONNEL TO MAKE REPAIRS OR REPLACE MALFUNCTIONING COMPONENTS ACCORDING TO INSTRUCTIONS PROVIDED IN MANUAL.

FAILURE TO FOLLOW THESE INSTRUCTIONS CAN RESULT IN DEATH OR EQUIPMENT DAMAGE

1.1.6 Material Handling Precautions, ESD



CAUTION

Electrostatic Sensitive Devices

This equipment may contain electrostatic devices

- Protect from electrostatic discharge.
- Electronic modules and components should be touched only when this is unavoidable e.g. soldering, replacement.
- Before touching any component of the cabinet you shall bring your body to the same potential as the cabinet by touching a conductive earthed part of the cabinet.
- Electronic modules or components must not be brought in contact with highly insulating materials such as plastic sheets, synthetic fiber clothing. They must be laid down on conductive surfaces.
- The tip of the soldering iron must be grounded.
- Electronic modules and components must be stored and transported in conductive packing.

Failure to follow this instruction can result in equipment damage

1.1.7 Arc Flash and Electric Shock Hazard



DANGER

SERIES CIRCUITS HAVE HAZARDOUS VOLTAGES

THIS EQUIPMENT PRODUCES HIGH VOLTAGES TO MAINTAIN THE SPECIFIED CURRENT - DO NOT DISCONNECT WHILE ENERGIZED.

- ALLOW ONLY QUALIFIED PERSONNEL TO PERFORM MAINTENANCE, TROUBLESHOOTING, AND REPAIR TASKS.
- ONLY PERSONS WHO ARE PROPERLY TRAINED AND FAMILIAR WITH ADB SAFEGATE EQUIPMENT ARE PERMITTED TO SERVICE THIS EQUIPMENT.
- AN OPEN AIRFIELD CURRENT CIRCUIT IS CAPABLE OF GENERATING >5000 VAC AND MAY APPEAR OFF TO A METER.
- NEVER UNPLUG A DEVICE FROM A CONSTANT CURRENT CIRCUIT WHILE IT IS OPERATING; ARC FLASH MAY RESULT.
- DISCONNECT AND LOCK OUT ELECTRICAL POWER.
- ALWAYS USE SAFETY DEVICES WHEN WORKING ON THIS EQUIPMENT.
- FOLLOW THE RECOMMENDED MAINTENANCE PROCEDURES IN THE PRODUCT MANUALS.
- DO NOT SERVICE OR ADJUST ANY EQUIPMENT UNLESS ANOTHER PERSON TRAINED IN FIRST AID AND CPR IS PRESENT.
- CONNECT ALL DISCONNECTED EQUIPMENT GROUND CABLES AND WIRES AFTER SERVICING EQUIPMENT. GROUND ALL CONDUCTIVE EQUIPMENT.
- USE ONLY APPROVED ADB SAFEGATE REPLACEMENT PARTS. USING UNAPPROVED PARTS OR MAKING UNAPPROVED MODIFICATIONS TO EQUIPMENT MAY VOID AGENCY APPROVALS AND CREATE SAFETY HAZARDS.
- CHECK THE INTERLOCK SYSTEMS PERIODICALLY TO ENSURE THEIR EFFECTIVENESS.
- DO NOT ATTEMPT TO SERVICE ELECTRICAL EQUIPMENT IF STANDING WATER IS PRESENT. USE CAUTION WHEN SERVICING ELECTRICAL EQUIPMENT IN A HIGH-HUMIDITY ENVIRONMENT.
- USE TOOLS WITH INSULATED HANDLES WHEN WORKING WITH AIRFIELD ELECTRICAL EQUIPMENT.

FAILURE TO FOLLOW THESE INSTRUCTIONS CAN RESULT IN DEATH OR EQUIPMENT DAMAGE

2.0 RELIANCE L-861T Elevated Taxiway Edge LED (ETES) Light

The RELIANCE ETES-L LED elevated light fixture is used to define the edges of airport taxiways and has an average LED life of 100,000 hours under high-intensity conditions and more than 180,000 hours under typical operating conditions, resulting in significant reduction or even elimination of ongoing maintenance costs and periodic re-lamping expenses.

The RELIANCE ETES-L with arctic option prevents ice and snow buildup from obscuring light output; it melts ice similar to the way a traditional incandescent fixture does. Not only is the light ideal for wintry conditions, but for optimal visibility during the day because of the blue optical outer lens. 10/15 W and 20/25 W isolation transformers are available for use with RELIANCE ETES-L fixtures to match fixture load for optimal efficiency. A standard 30/45W isolation transformer may also be used.

Figure 1: RELIANCE L-861T Elevated Taxiway Edge LED (ETES)



2.1 About this manual

The manual shows the information necessary to:

- Install
- Carry Out Maintenance
- Carry Out Troubleshooting on the ETES.

2.2 How to work with the manual

- Familiarize yourself with the structure and content.
- Carry out the actions completely and in the given sequence.

3.0 Introduction

This section describes the ADB SAFEGATE RELIANCE L-861T elevated taxiway edge LED (ETES) light. See [Figure 5](#).

Typical installation is on a L-867 light base. The housing assembly includes the electronic package. For the main items in the assembly, see [Figure 6](#).

The optional mounting is stake mounted on a 30-inch galvanized steel stake. The fixtures can also be mounted on a base plate for a 12- or 16-inch diameter L-867 base with 1-1/2-inch NPS or a special 2-inch NPT frangible reducer coupling for an existing installation that has 2-inch NPT hubs in the base plate. Base mounting is recommended because maintenance is easier to perform. Stake-mounted lights require transformers, cables, and connectors that are designed for direct earth burial.

3.1 Taxiway Edge, L-861T(L)

Compliance with Standards

FAA:	L-861T(L) AC 150/5345-46 (Current Edition) and the FAA Engineering Brief No. 67. ETL Certified.
ICAO:	Annex 14, Vol. 1, para. 5.3.17; 5.3.18 (for photometry) Chromaticity - Appendix 1, Section 2.3.1 (Blue LED) Frangibility - Section 5.3.1.6

CE

Uses

Taxiway edge fixture is used to delineate the edges of airport taxiways.

FAA

- Taxiway Edge L-861(L)

ICAO

- Taxiway Edge

Features

- Average LED life of 100,000 hours under high-intensity conditions and more than 180,000 hours under typical operating conditions, which significantly reduces ongoing maintenance costs and periodic re-lamping expenses.
- The RELIANCE® taxiway edge fixture with heater fixture MTBF is at least 180,000 operating hours.
- UV-resistant polycarbonate outer lens option minimizes risk of lens damage if fixture is knocked over.
- Isolation transformers are available for use with the fixtures to match fixture load for optimal efficiency.
- Rugged low-profile design reduces damage due to jet blast.
- Provides $\pm 4.5^\circ$ vertical adjustment.
- Aluminum casting, stainless steel hardware, and protected with aviation yellow powder coat finish. Locking ring is protected with aviation blue powder coat finish.

Operating Conditions

Temperature:	-40 °F to +131 °F / -40 °C to +55 °C
Wind:	Withstands wind velocities up to 300 mph / 480 kph

Power Supply

Current Driven

RELIANCE LED lights have been designed to work with any IEC or FAA-compliant transformer up to 100 W without affecting performance or lifetime of the light or the transformer. Optional monitoring function of the individual light

source. In case of a defect, the LED light automatically disconnects from the secondary side of the isolation transformer, resulting in an open circuit condition.

Current Driven



Note

The power usage is the same for the version with Monitoring.

ETES Fixture w/ heater	Fixture Load	Isolation Transfmr.	Isol. XF Load	CCR Load
Off	12 VA	20/25 W	7.5 VA	19.5 VA
Off	12 VA	30/45 W	8.4 VA	20.4 VA
On	25 VA	20/25 W	7.5 VA	32.5 VA
On	25 VA	30/45 W	9 VA	34 VA
ETES Fixture w/out heater	Fixture Load	Isolation Transfmr.	Isol. XF Load	CCR Load
Off	12 VA	10/15 W	3 VA	15 VA
Off	12 VA	30/45 W	8.4 VA	20.4 VA

Voltage Driven

Input voltage:	95 VAC (min.) - 264 VAC (max.), 50/60 Hz
Maximum input power (w/out heater):	10.2 VA
Maximum input power (w/heater):	25.2 VA at 120 VAC

Packaging

Assembled Fixtures	Dimensions of Cartons		Indiv. Weight ¹ lb / kg
	Individual in / cm	15 per box in / cm	
14-inch OAH	20.5 × 6.5 × 6.5 /	19.5 × 23.5 × 15.75 /	2.75 lb
	52 × 16.5 × 16.5	50 × 60 × 52	1.25 kg
24-inch OAH	31 × 6.5 × 6.5 /	29.5 × 23.5 × 15.75 /	4 lb
	79 × 17 × 17	75 × 60 × 40	1.81 kg
30-inch OAH	37 × 6.5 × 6.5 /	36 × 23.5 × 15.7 /	4.75 lb
	94 × 16.5 × 16.5	91.5 × 60 × 40	2.15 kg

¹Weight based on unpackaged fixture with arctic option.

Ordering Code



LED Color

- 1 = Blue (Glass)
- 2 = Red (special applications only)¹
- 3 = White (special applications only)¹
- 4 = Green (special applications only)¹
- 5 = Yellow (special applications only)¹
- 6 = Blue (UV-resistant Polycarbonate)
- 9 = Yellow (UV-resistant Polycarbonate)¹
- A = Red (UV-resistant Polycarbonate)¹

Fixture Height

- R = ICAO <350mm OAH (2" coupling), 11.5 TPI¹⁴
- W = ICAO <350mm OAH (2" coupling), 11 TPI¹⁴
- 0 = 14" OAH without coupling¹³
- 1 = 14" OAH (1.5" coupling), 12 TPI
- 2 = 24" OAH (1.5" coupling), 12 TPI
- 3 = 30" OAH (1.5" coupling), 12 TPI
- 4 = 14" (2" coupling), 11.5 TPI
- 5 = 24" OAH (2" coupling), 11.5 TPI
- 6 = 30" OAH (2" coupling), 11.5 TPI
- 7 = 14" OAH (2" coupling), 11 TPI¹⁴
- 8 = 24" OAH (2" coupling), 11 TPI¹⁴
- 9 = 30" OAH (2" coupling), 11 TPI¹⁴
- A = Style 6 cord¹⁶
- B = 14" OAH (1.5" slot coupling)¹
- C = 24" OAH (1.5" slot coupling)¹
- D = 30" OAH (1.5" slot coupling)¹
- E = 14" OAH (1.5" x 2" slot coupling), 11.5 TPI¹
- F = 24" OAH (1.5" x 2" slot coupling), 11.5 TPI¹
- G = 30" OAH (1.5" x 2" slot coupling), 11.5 TPI¹
- H = Style 1 cord¹³⁶
- L = 14" OAH (2" coupling), 11.5 TPI, 22" cordset
- M = 18" OAH (1.5" x 2" slot coupling), 11.5 TPI¹
- N = 18" OAH (1.5" coupling)
- P = 18" OAH (2" coupling), 11.5 TPI
- Q = 18" OAH (2" coupling), 11 TPI¹⁴
- S = 20" OAH (1.5" coupling)
- T = 20" OAH (1.5" slot coupling)¹
- U = 20" OAH (2" coupling), 11 TPI¹⁴
- V = 20" OAH (2" coupling), 11.5 TPI
- Z = 16" OAH (1.5" coupling), 12 TPI

Power

- 1 = Current Driven, 50/60 Hz
- M = Current Driven, Monitored 50/60hz¹⁵
- 3 = 95-264 VAC, 50/60 Hz
- A = APS Advanced Power Supply

Arctic Option

- 0 = Without Arctic Option
- 1 = With Arctic Option

Version

- C = ROW Version
- = Not used for Buy American Preference

Ordering Code Notes

1. Not Submitted for ETL testing.
2. When powered by a parallel circuit, heater is designed for use at only 120 VAC, +/- 10%, 50/60Hz.

3. Configuration sold with no column and no coupling.
4. Normally used in metric applications.
5. If digit 7 = M, digit 9 must be = C.
6. No column or frangible coupling.

4.0 Installation

4.1 Installation Safety Considerations



WARNING

Electric Shock

Read installation instructions in their entirety before starting installation.

- Become familiar with the general safety instructions in this section of the manual before installing, operating, maintaining or repairing this equipment.
- Read and carefully follow the instructions throughout this manual for performing specific tasks and working with specific equipment.
- Follow all applicable safety procedures required by your company, industry standards and government or other regulatory agencies.
- Install all electrical connections to local code.
- Use only electrical wire of sufficient gauge and insulation to handle the rated current demand. All wiring must meet local codes.
- Route electrical wiring along a protected path. Make sure they will not be damaged by moving equipment.

Failure to follow these warnings may result in serious injury or equipment damage.

4.2 Introduction

This section provides instructions for installing the L-861T medium intensity elevated light fixture. Refer to the airport project plans and specifications for the specific installation instructions.

4.2.1 Unpacking

The equipment is shipped ready for installation. Handle equipment very carefully to prevent component damage. Unpack the carton upon receipt and check the contents and their condition. Note any exterior damage to the carton that might lead to detection of equipment damage.

If you note any damage to any equipment, file a claim with the carrier immediately. The carrier may need to inspect the equipment.

4.3 Placement

This subsection describes the placement of the L-861T light fixtures.

Follow the guidelines below, along with FAA specification AC 150/5340-30 and site plans, when placing the L-861T light fixture.

- The L-861T light fixture is normally positioned a maximum of 10 feet (3.048 m) off the edge of the hard surface of the taxiway, and in a straight line with all other light fixtures on the straight sections of the taxiways.
- The longitudinal spacing of the light fixtures should not exceed 200 feet (60.96 m) to define the lateral limits of the taxiing paths. The longitudinal spacing of the lights is influenced by the physical layout of the taxiways.
- Closer spacing of the lights should be provided on short taxiway sections, curves, and entrances to taxiways from runways or aprons.

4.4 Installation Procedures

This subsection provides installation instructions for the L-861T light fixtures.

4.4.1 Base Mounting

L-861T light fixtures can be mounted on an L-867 base plate with a diameter and bolt-hole corresponding to either a 12-inch- (304.8 mm-) diameter L-867B base or a 16-inch- (406.4 mm-) diameter L-867D base plate per FAA AC 150/5345-46.

The base plate is designed to receive a frangible coupling using a male thread. The standard coupling thread is 1-1/2" -12 TPI. The optional thread is 2"-11 TPI NPS. A gasket is supplied with the base plate to form a watertight seal between the base plate and the L-867 light base per FAA AC 150/5345-42.



Note

Install the base according to FAA Advisory Circular AC 150/5340-30 and site plans.

4.4.2 Light Base Mounting

To install the base, perform the following procedure:

1. Install the L-867 base on undisturbed soil. If the soil is unsuitable, remove soil to an adequate depth and replace with compacted acceptable material.
2. Use light bases having a drain hole to prevent water accumulation, In closed duct systems and install in soil conditions with good drainage.
3. Orient the cable entrance hubs of the light base in the proper directions according to site plans.
4. Level the light base so that the mounting flange surface is level with the finished grade.
5. With the base at the proper orientation and held at proper elevation, place approximately 4-inches (101.6 mm) of concrete back-fill around the outside base.
6. If the concrete back-fill is omitted, the earth back-fill must be compacted to maintain proper elevation and orientation of the base.
7. Slope the top of the concrete away from the flange portion of the base so the sloped outer edges of the concrete are at surface grade.
8. Connect the field circuit to the appropriate isolation transformer. Refer to Power Supply.
9. Use a brick to raise the transformer about 3 inches above the bottom surface of the L-867 light base to avoid the possibility of the transformer being partially immersed in water in case water accumulates above the level of the ducts or pipes.

After you have connected the transformer, check the continuity of the series loop by following the following steps:

1. Wrap the connector joints in the primary circuit with at least one layer of rubber or synthetic rubber tape and one layer of plastic tape one-half lapped, extending at least 1-1/2 inches (3.81 cm) on each side of the joint.
2. Clamp the female secondary plug from the isolation transformer to the L-867 base plate fitting using the clamp device supplied with the base plate.
3. Attach the base plate (Figure 2) with the base plate gasket to the L-867 base using six 3/8-16 stainless steel bolts. Apply a drop of Loctite number 243 to each bolt thread, and use a torque wrench to torque bolts down to 100/110 inch-pounds (11.3 N•m).
4. Once the base plate has been installed the light fixture assembly is ready to install.
5. Connect the male L-823 plug (Figure 4) from the light fixture to the female plug on the secondary lead of the isolation transformer by first loosening the frangible coupling hex screw (Figure 4) until the coupling is free. Then retighten the hex screw finger-tight.
6. Plug the L-823 into the mating isolation transformer secondary lead.
7. Loosen the hex screw on the coupling to free the coupling. Hand screw the coupling into the base plate hub. Finish tightening the coupling with a wrench. Torque to 75 in-lbs (8.5 N•m).



WARNING

Do not tighten the coupling if the coupling hex screw is still tight.

Failure to follow these instructions will damage the L-823 connection to the transformer.

8. Tighten the coupling screw that secures the column to the frangible coupling and the adjustable head.

9. Level the light fixture. Refer to [Light Fixture Leveling](#).

Figure 2: ETES L-861T(L) fixture mounted on an L-867B base can

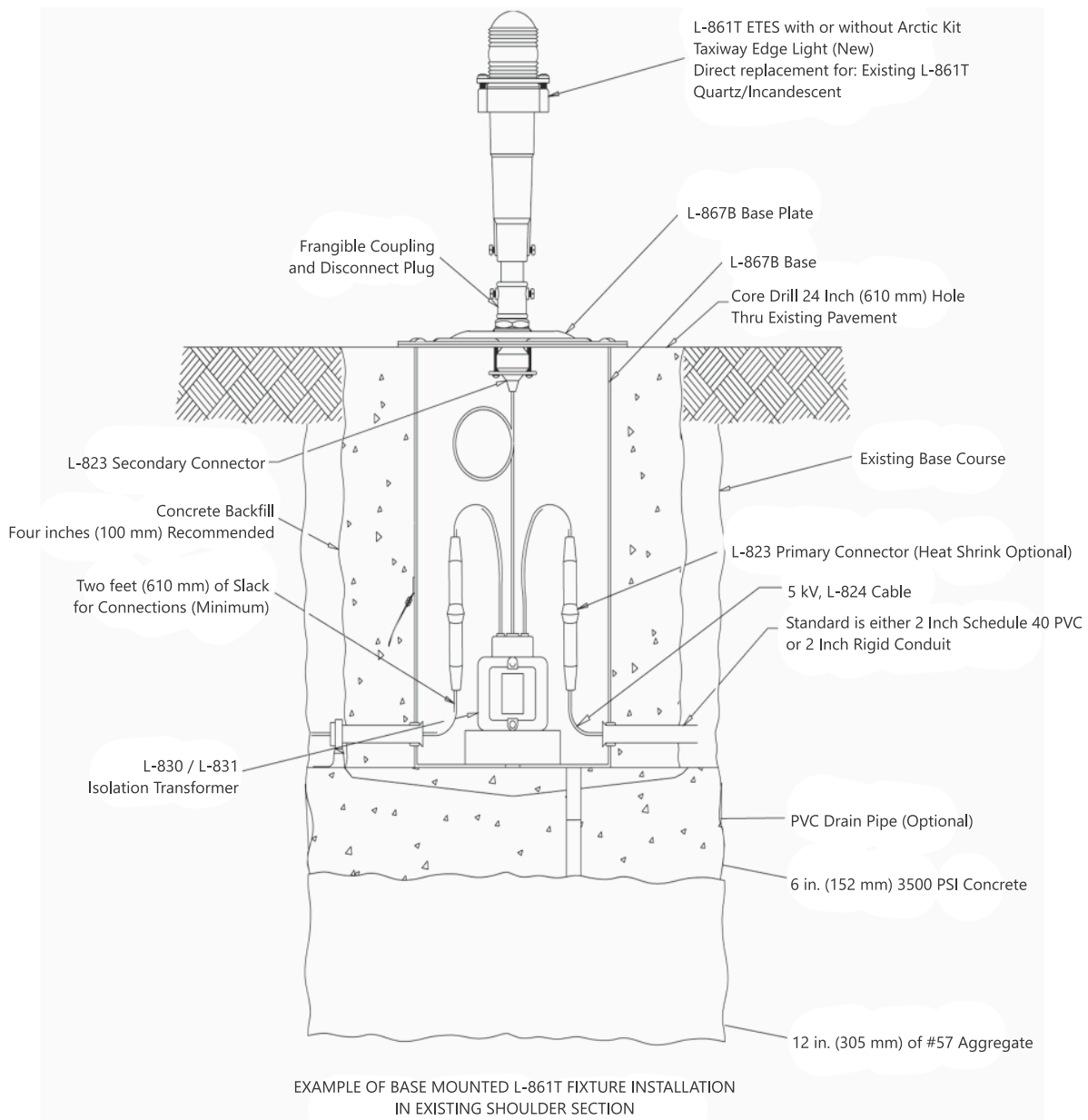
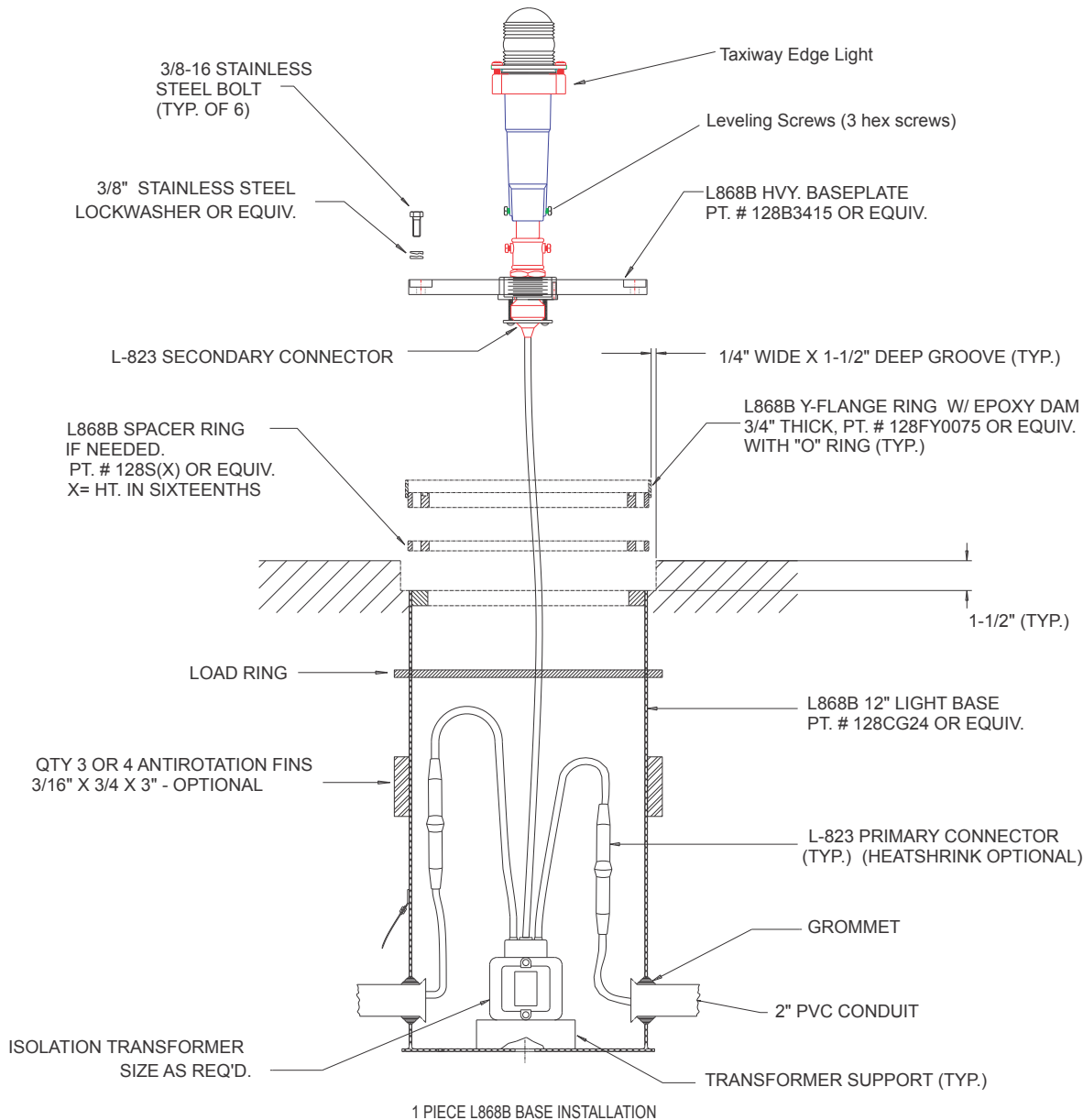

Figure 3: ETES L-861T(L) fixture mounted on an L-868B base can



4.4.3 Light Fixture Leveling

Level the light fixture only after mounting it on the base.

To level the light fixture, perform the following procedure:

1. Slightly loosen the three hex screws in the bottom of the housing. See [Figure 2](#).
2. Place a level on top of the housing rotate housing until level.
3. Tighten the three hex screws to lock in place.
4. Torque to 75 in-lbs (8.5 N•m).

4.4.4 Stake Mounting

Mount the column light fixtures on 30 inch (762 mm) galvanized steel stakes with a fitting attached to the top of each stake to receive the male thread of the frangible coupling. Stake mounting requires cables and connections that are designed for direct earth burial. Install according to appropriate FAA and local contractor specifications.

To mount the L-861T light fixture on a stake, assemble the stake by attaching the stake hub to the metal stake using two 3/8-16 x 3/4-in. hex head screws and 3/8-in. lock washers.

Figure 4: Stake Assembly

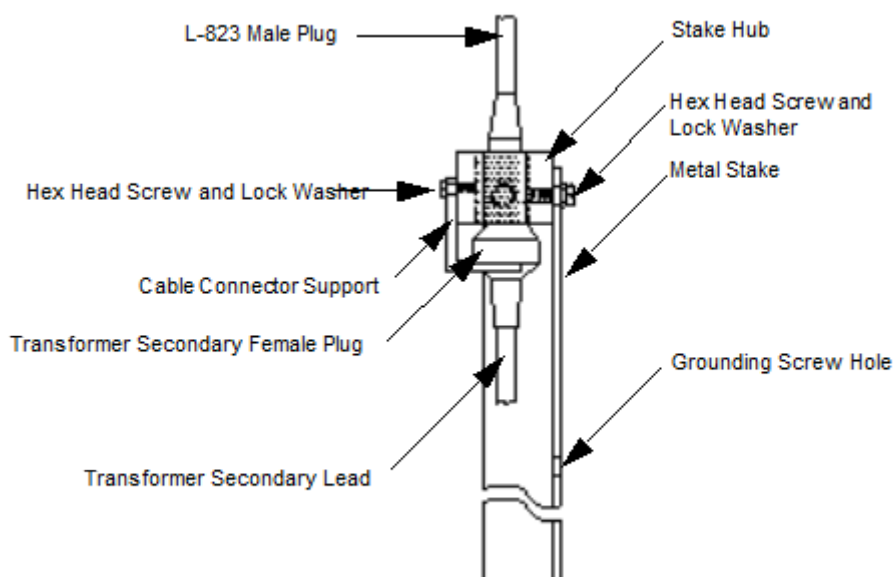

1. Install the stake in 6-inch (152.4-mm) diameter holes in the ground at a depth of 30 inches (762 mm) so that the mounting hub of the stake is level.
2. The top of the stake should be even with the ground within one degree of the vertical. In areas where frost may cause heaving, anchor the stake with concrete and use a permeable backfill material such as sand around the buried electrical components. Cover the top surface with an impervious material to reduce moisture penetration.



WARNING

Do not drive stakes. Driving stakes may damage the stake and cause light fixture misalignment. Refer to FAA specification AC 150/5340-30. Failure to follow these instructions may damage the stake.

3. Backfill around the stake with compacted earth passing a 1-inch (25.4 mm) sieve.
4. Use a bubble level or carpenter's level to ensure the stake is vertical before backfilling around stake. Backfill with concrete in case of unstable soil conditions.
5. Make electrical connections by installing the transformer primary cables to the field circuit. Then insert the transformer secondary plug in the cable connector supports' forked tine and attach the cable connector support to the stake hub using 1/4 – 20 × 3/4-in. hex head screw and 1/4-in. split lock washer.
6. The small hole at the lower end of the stake is provided for a counterpoise wire connection.
7. Install the light fixture on the stake.

5.0 Maintenance Introduction

This section provides maintenance information for the L-861T LED elevated light.

5.1 Maintenance Schedule

To keep the L-861T light fixtures operating efficiently, follow a preventive maintenance schedule. Refer to Table 6. Refer to FAA AC 150/5340-26 for more detailed information.

Table 1: L-861T Light Fixture Maintenance

Interval	Maintenance Task	Action
Weekly	Check for vegetation.	Remove vegetation. Use weed killer.
Monthly	Check for misaligned fixture.	Straighten, level, and align.
	Check for dirty optical column.	Clean with glass cleaner.
	Check for dirty frangible coupling weep holes (for stake-mounted fixtures only).	Clean weep holes.
Annually	Check for improper ground elevation.	Grade so frangible point is approximately 1 inch (25.4 mm) above ground elevation.
	Check for improper light elevation.	Maintain same elevation for all light fixtures.
	Check for corrosion present or paint loose or chipped.	Scrape and repaint.
	Check for chipped paint on exterior body and fixture.	Touch up paint as necessary.
Unscheduled	Make prediction of heavy snowfall, if necessary.	Use red flags or sticks to mark the location of fixtures to facilitate snow removal and lessen the chance of damage to fixtures by snow removal equipment.

5.1.1 Assembly Instructions

The L-861T ETES elevated light is assembled at the factory. Use the assembly instructions below when you need to disassemble/ assemble parts for repair or maintenance purposes

To assemble parts, perform the following procedure and refer to [Figure 2](#):

- Apply a light coat of anti-seize compound on the locking ring threads to make assembly and disassembly easier.
- Insert the cord through the column and the frangible coupling and secure both with the hex screws. See [Electronics Module Replacement](#).

For more information, see [Spare Parts](#) and repair/replace components in [ETES Parts](#).

6.0 Ordering Code

Ordering Code



LED Color

- 1 = Blue (Glass)
- 2 = Red (special applications only)¹
- 3 = White (special applications only)¹
- 4 = Green (special applications only)¹
- 5 = Yellow (special applications only)¹
- 6 = Blue (UV-resistant Polycarbonate)
- 9 = Yellow (UV-resistant Polycarbonate)¹
- A = Red (UV-resistant Polycarbonate)¹

Fixture Height

- R = ICAO <350mm OAH (2" coupling), 11.5 TPI¹⁴
- W = ICAO <350mm OAH (2" coupling), 11 TPI¹⁴
- 0 = 14" OAH without coupling¹³
- 1 = 14" OAH (1.5" coupling), 12 TPI
- 2 = 24" OAH (1.5" coupling), 12 TPI
- 3 = 30" OAH (1.5" coupling), 12 TPI
- 4 = 14" (2" coupling), 11.5 TPI
- 5 = 24" OAH (2" coupling), 11.5 TPI
- 6 = 30" OAH (2" coupling), 11.5 TPI
- 7 = 14" OAH (2" coupling), 11 TPI¹⁴
- 8 = 24" OAH (2" coupling), 11 TPI¹⁴
- 9 = 30" OAH (2" coupling), 11 TPI¹⁴
- A = Style 6 cord^{1 6}
- B = 14" OAH (1.5" slot coupling)¹
- C = 24" OAH (1.5" slot coupling)¹
- D = 30" OAH (1.5" slot coupling)¹
- E = 14" OAH (1.5" x 2" slot coupling), 11.5 TPI¹
- F = 24" OAH (1.5" x 2" slot coupling), 11.5 TPI¹
- G = 30" OAH (1.5" x 2" slot coupling), 11.5 TPI¹
- H = Style 1 cord^{1 3 6}
- L = 14" OAH (2" coupling), 11.5 TPI, 22" cordset
- M = 18" OAH (1.5" x 2" slot coupling), 11.5 TPI¹
- N = 18" OAH (1.5" coupling)
- P = 18" OAH (2" coupling), 11.5 TPI
- Q = 18" OAH (2" coupling), 11 TPI¹⁴
- S = 20" OAH (1.5" coupling)
- T = 20" OAH (1.5" slot coupling)¹
- U = 20" OAH (2" coupling), 11 TPI¹⁴
- V = 20" OAH (2" coupling), 11.5 TPI
- Z = 16" OAH (1.5" coupling), 12 TPI

Power

- 1 = Current Driven, 50/60 Hz
- M = Current Driven, Monitored 50/60hz¹⁵
- 3 = 95-264 VAC, 50/60 Hz
- A = APS Advanced Power Supply

Arctic Option

- 0 = Without Arctic Option
- 1 = With Arctic Option

Version

- C = ROW Version
- = Not used for Buy American Preference

Ordering Code Notes

1. Not Submitted for ETL testing.
2. When powered by a parallel circuit, heater is designed for use at only 120 VAC, +/- 10%, 50/60Hz.
3. Configuration sold with no column and no coupling.
4. Normally used in metric applications.
5. If digit 7 = M, digit 9 must be = C.
6. No column or frangible coupling.

7.0 Troubleshooting

This section contains troubleshooting information for the L-861T light fixture. This information covers only the most common problems that you may encounter. If you cannot solve the problem with the information given here, contact your local ADB SAFEGATE representative for help.



WARNING

Allow only qualified personnel to perform the following tasks. Observe and follow the safety instructions in this document and all other related documentation.

De-energize the circuit and lock out the circuit or regulator so that the circuit cannot be energized by remote means before attempting to service the fixture.

Failure to follow these instructions may cause equipment damage or, severe injury or death.

7.1 Troubleshooting Procedures

Refer below for troubleshooting procedures for the L-861T LED elevated light.

Problem	Possible Cause	Corrective Action
LED not lighting	Defective electronic module	Replace the electronic module.
	Loose wire connections	Tighten wire connections.
	Deteriorated wire insulation	Replace wires.
	Moisture present in fixture	Open and dry the fixture. Inspect the glassware for cracks. Replace the electronic module, seals, and damaged glassware assembly.
LED too dim	Dirty Glassware	Clean the glass lens.
	LED or electronic module failed	Replace the LED or the electronic module.
Ice forming on lens	Defective or missing arctic kit	Remove the glassware assembly and check to see if heating element is installed. If missing or defective install new arctic kit. See Spare Parts .

7.2 Repair

This section provides instructions for repairing the L-861T LED (ETES) light fixture. It includes instructions for replacing the L-861T LED electronic module, the arctic kit, the L-823 cord set, and the Glassware or Polycarbonate Lens Assembly. Replacing an existing L861T incandescent fixture with an L-861T LED fixture is also covered in this section.



WARNING

Allow only qualified personnel to perform the following tasks. Observe and follow the safety instructions in this document and all other related documentation.

De-energize the circuit and lock out the circuit or regulator so that the circuit cannot be energized by remote means before attempting to service the fixture.

Failure to follow these instructions may cause equipment damage or, severe injury or death.

7.2.1 Access to Internal Components

Accessing the internal components is achieved by removing the fixture from the field by performing the following procedure:

1. De-energize and lock out the circuit.
2. Remove the light fixture from the mounting base by performing the following procedure:
3. See [Electronics Module Replacement](#). Loosen the hex bolt that attaches the frangible coupling to the column.
4. Remove the frangible coupling from the base plate female thread.
5. Disconnect the L-823 plug of the light fixture from the female plug on the secondary lead of the isolation transformer.
6. Remove the glassware assembly, by rotating it counterclockwise.

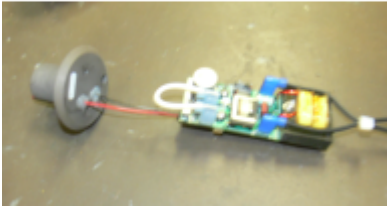

7.2.2 LED and Arctic Kit or Electronic Module Replacement

If the LED or arctic kit must be removed/replaced proceed as follows:

1. Grasp the LED assembly and gently lift the assembly out of the housing.
2. Separate the electrical disconnects (1 connection if LED only, 3 connections if arctic kit is installed).
3. If replacement is necessary see [ETES Parts](#).

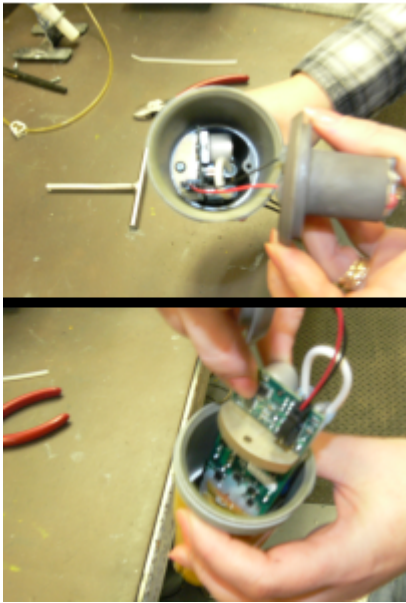

If the electronic module must be removed/replaced proceed as follows:

1. Remove LED components as described above then locate and remove the two screws attaching the electronic module to the housing and remove the electronic module and the cord set assembly. The L-823 cord set will fit through the clearance hole in the housing.
2. If replacement is necessary see [ETES Parts](#).
3. Separate the disconnect between the electronic module and the cord set assembly.

7.2.3 Cord Set Replacement

If the L-823 cord set must be removed/replaced:

1. Remove the LED and electronic module as described above and then proceed as describe in the previous section. Replace the L-823 cord set. If replacement is necessary see [ETES Parts](#).
2. After parts have been removed/replaced, reassembly the items in reverse order and reinstall the Glassware Assembly. Conduct necessary tests to confirm that fixture works properly. Reinstall the Glassware Assembly. The fixture is now ready to be reinstalled on the base plate.
3. Level the reinstalled light fixture. Refer to [Light Fixture Leveling](#).

7.2.4 Glassware and Gasket Seal Replacement

All items in the Glassware Assembly are replaceable. ADB Safegate recommends that if the glass is broken replace both gaskets along with the new glassware. If gaskets are leaking, replace both gaskets.



1. Remove the Glassware Assembly by unscrewing the assembly from the body. Remove the two socket button head screws from the locking ring and then remove the Lens Attachment Ring by slipping it up and off of the glassware.
2. If glassware is broken or cracked, discard and install new glassware. When installing new glassware replace both gasket seals at the same time.
3. Check the position of the gasket against the lens before removing. The gasket sets at an angle when installed properly against the sloped surface of the outer flange of the glassware.
4. Peel the lower gasket off of the lock ring and replace with a new gasket.
5. After the upper glassware gasket has been installed all of the components are now ready to be reassembled together. BEFORE assembling parts, locate the beveled edge of the center hole in the Lens Attachment Ring. The beveled edge must be placed against the Lens Bearing Pad gasket. Slip the Attachment Ring over the glassware and place it against the pad gasket.
6. Align the holes in the attachment ring with the mating tapped holes in the lock ring and insert the two button head screws. Tighten the two screws evenly to prevent glassware from breaking. Torque the two screws to 25 +/- 5 In-Lbs.
7. The assembly is now ready to be reinstalled onto the fixture body.

7.2.5 Replacement of Existing Fixture

In replacing the existing quartz or incandescent light fixture with the L-861T LED fixture, you can either replace an existing light fixture and isolation transformer or replace only the existing light fixture (preferred).

1. Remove the existing L-861T light fixture and leave the isolation transformer in the light base.
2. Plug the LED fixture into the secondary of the L830 isolation transformer. Seal the isolation transformer secondary joint according to local airport practice.
3. Mount and level the new L-861T LED fixture.

8.0 RELIANCE ETES Parts

To order parts, call ADB SAFEGATE Customer Service or your local representative. Use this four-column parts list, and the accompanying illustration, to describe and locate parts correctly.

Figure 5: RELIANCE ETES Assembly

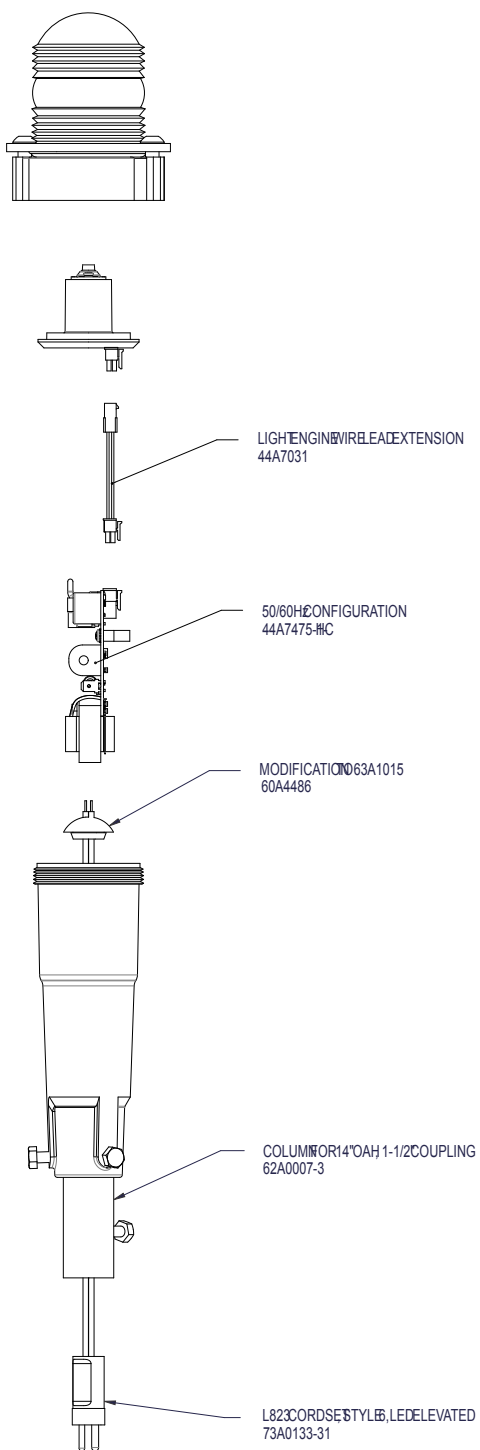

Figure 6: L-861T ETES Fixture (part 1 of 2)

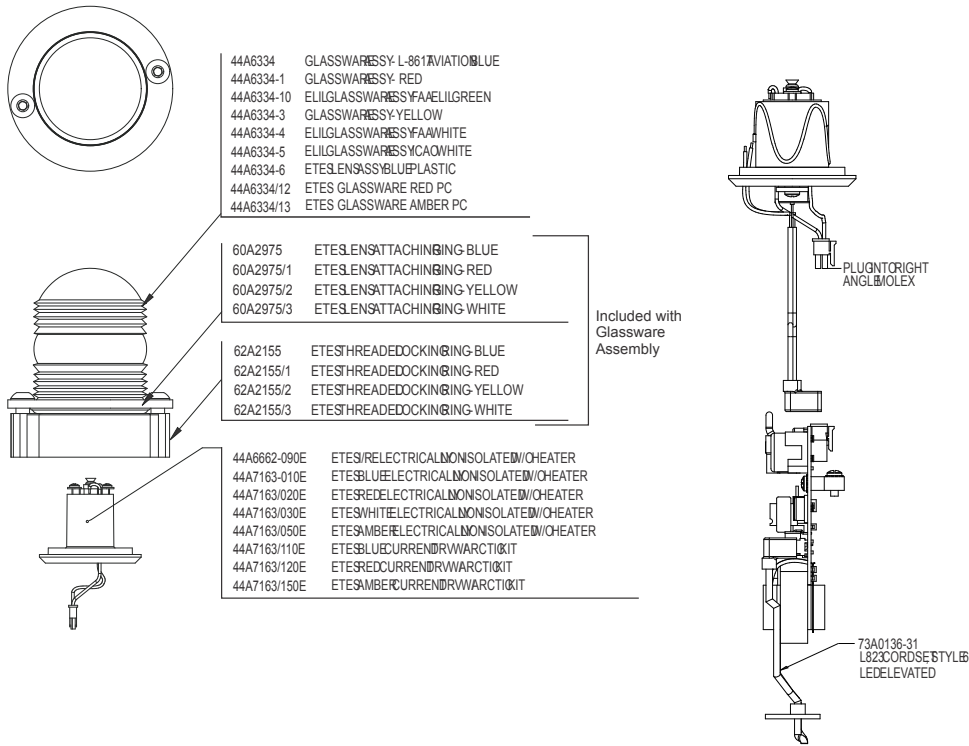

Figure 7: L-861T ETES Fixture (part 2 of 2)

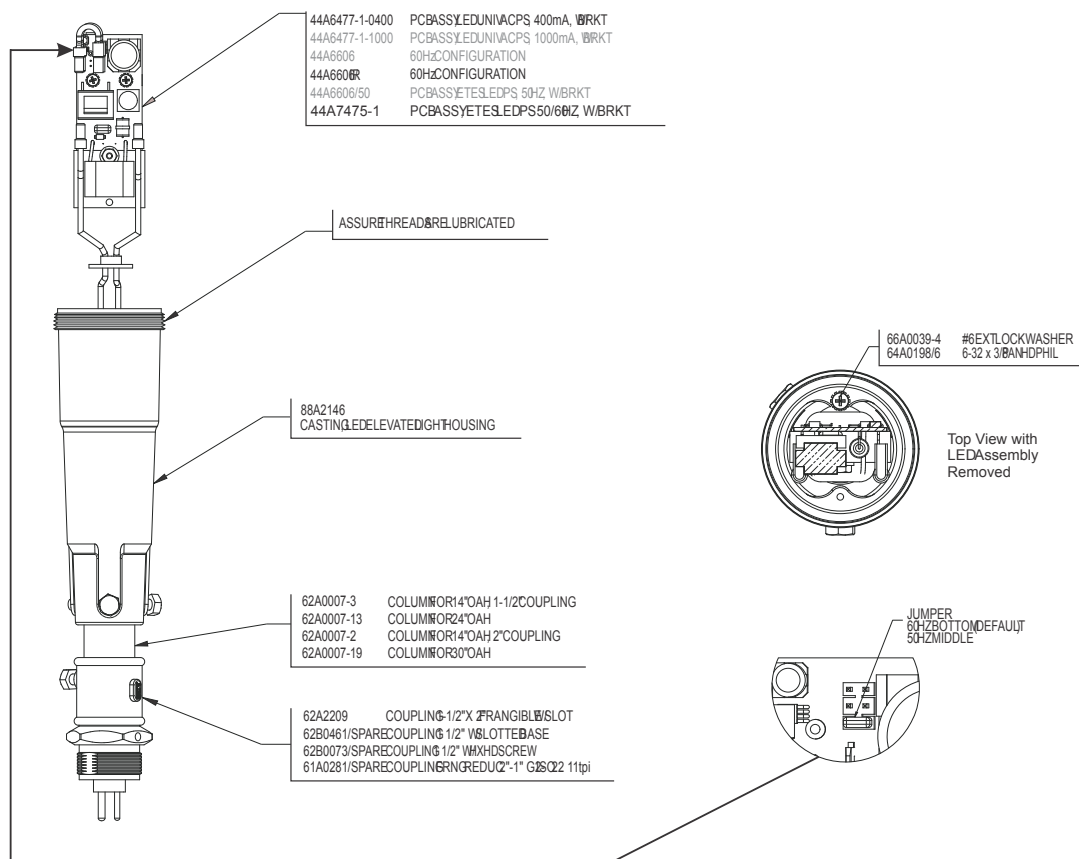

Figure 8: L-861T ETES Fixture and L-861T ETES (without heater)

ETES/XX10 (WITHOUT HEATER)
 ETES/XX20 (WITHOUT HEATER)

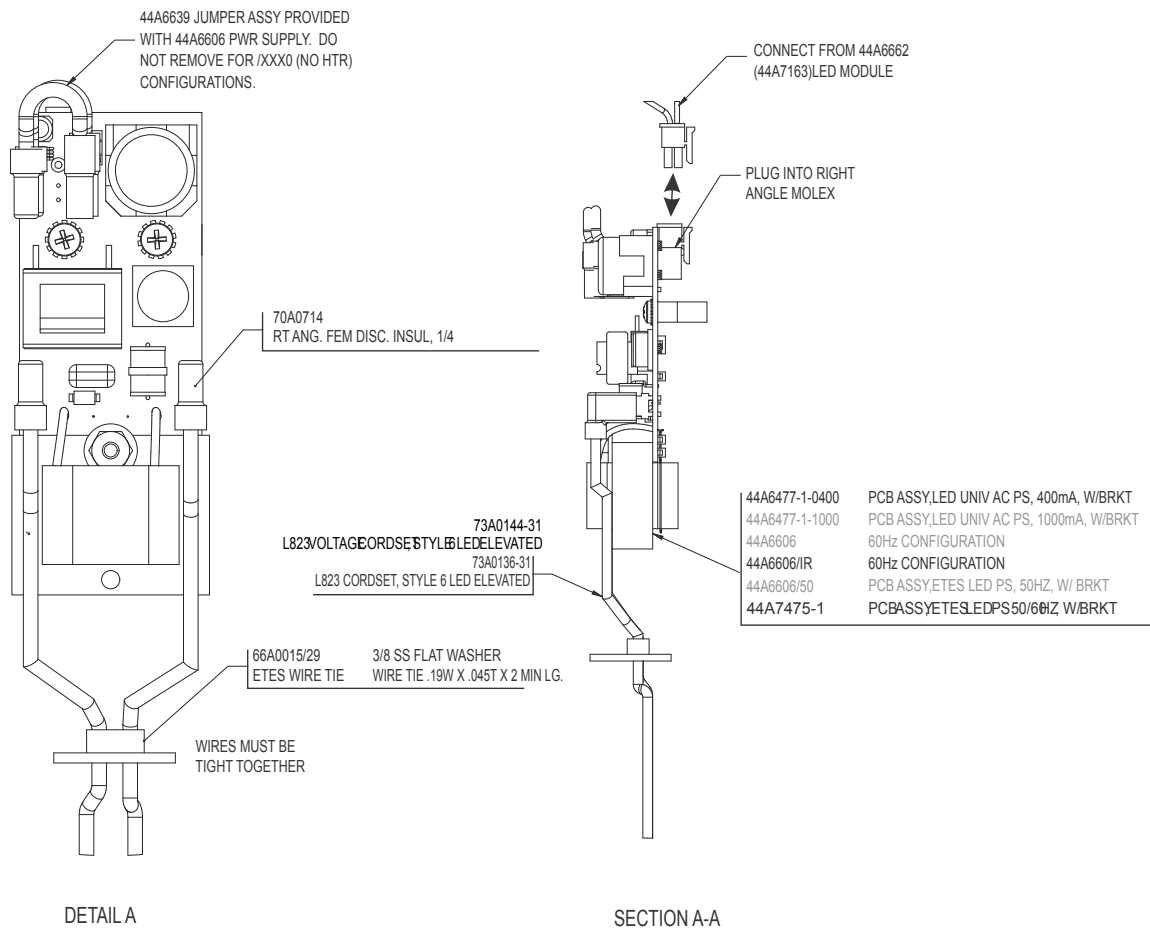
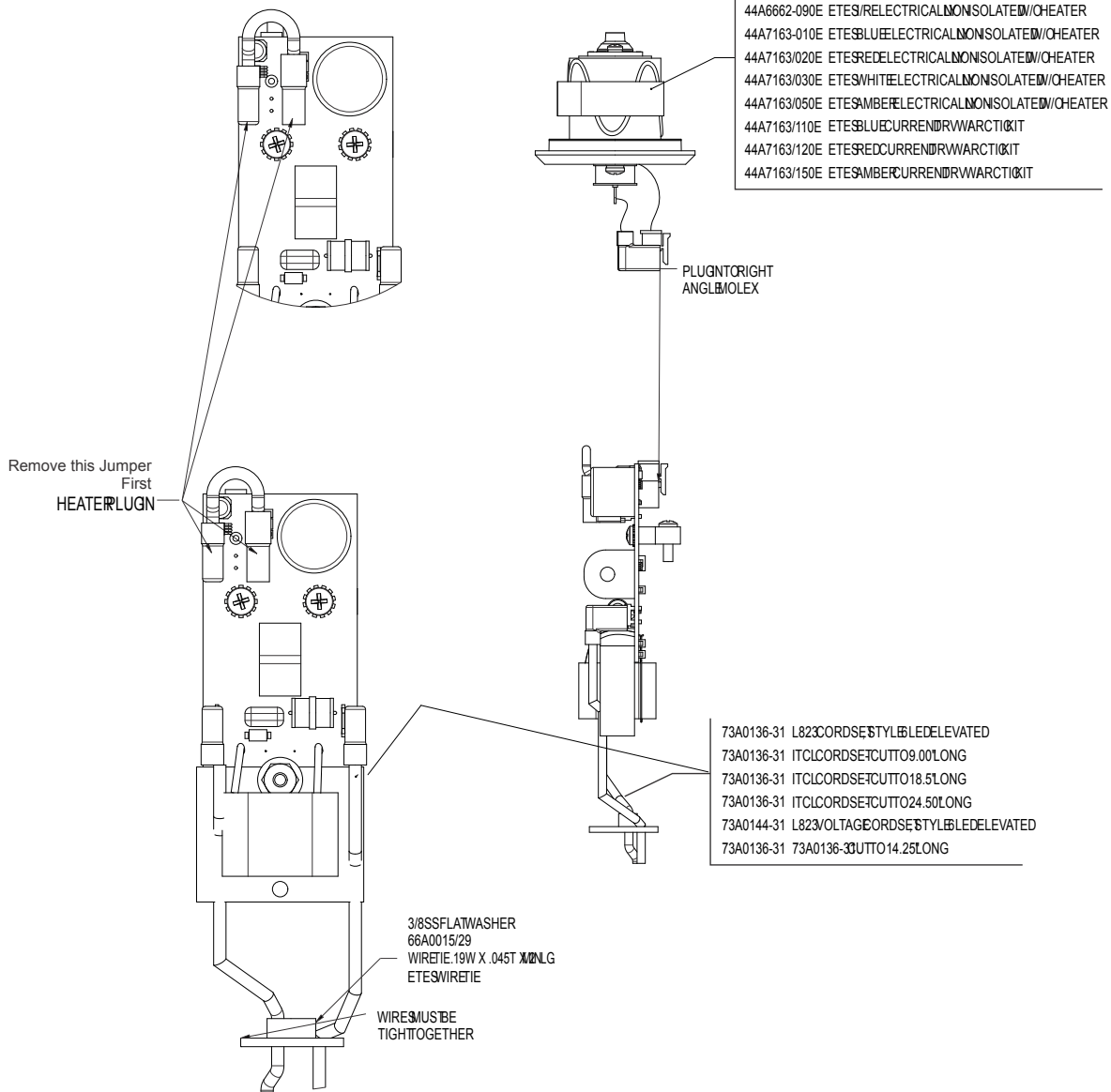

Table 2: Main Components Parts Not Shown List

Part Number	Description
67A0033	Thermal Joint Compound
67A0048	Anti-seize compound

Figure 9: L-861T ETES (with heater)

~~ETESXX11 WITH HEATER~~
~~ETESXX21 WITH HEATER~~



DRAWING NUMBER | REV
 ETESXXX | AJ02

8.1 L-861T Optional Stake Assembly Parts List

See [Figure 10](#). The optional stake assembly part number is 44B0348.

Figure 10: Stake Assembly

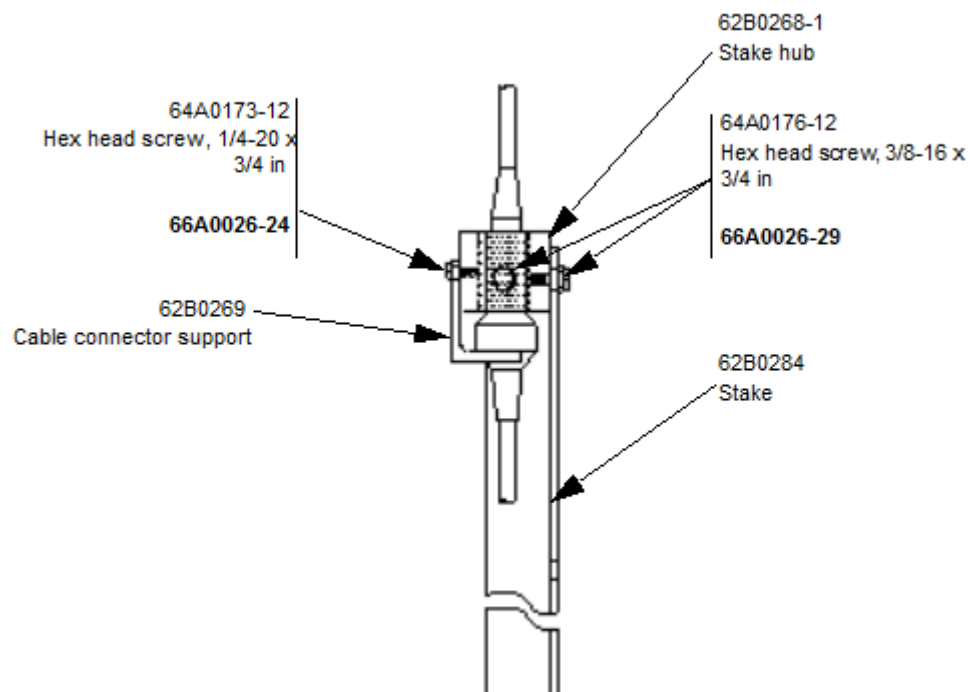

8.2 Optional Parts

Refer below for optional parts:

Part Number	Description
1935	12-inch-diameter base plate, 1.5-12 UNF tap (Supplied with gasket.)

8.3 Retrofit Charts

Figure 11: ETES LED Retro Fit Chart to Rev J and After 1/15/08

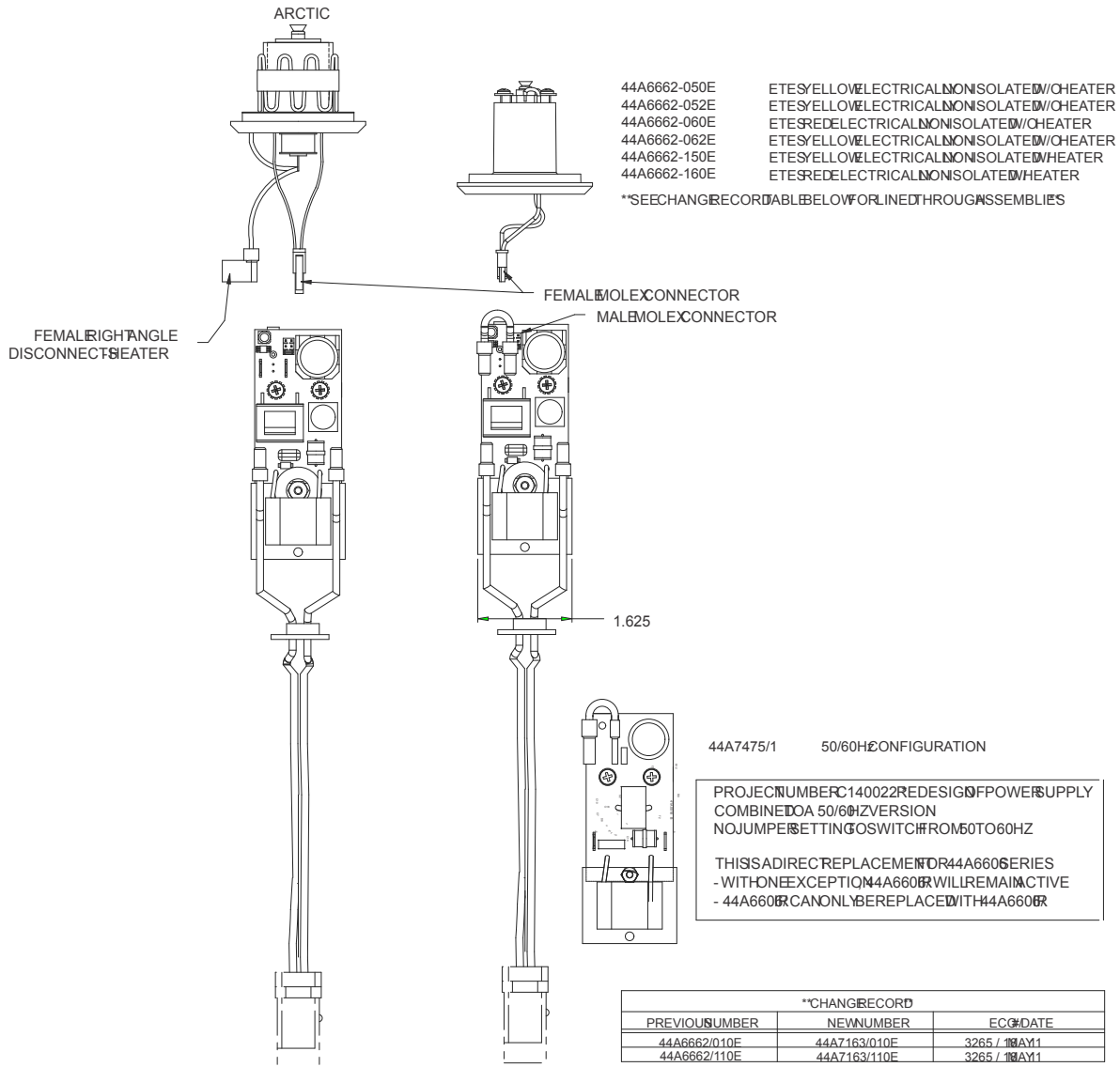

AFTER 1/15/08 (REV J)

Figure 12: ETES LED Retro Fit Chart Prior to 1/15/08 Rev J

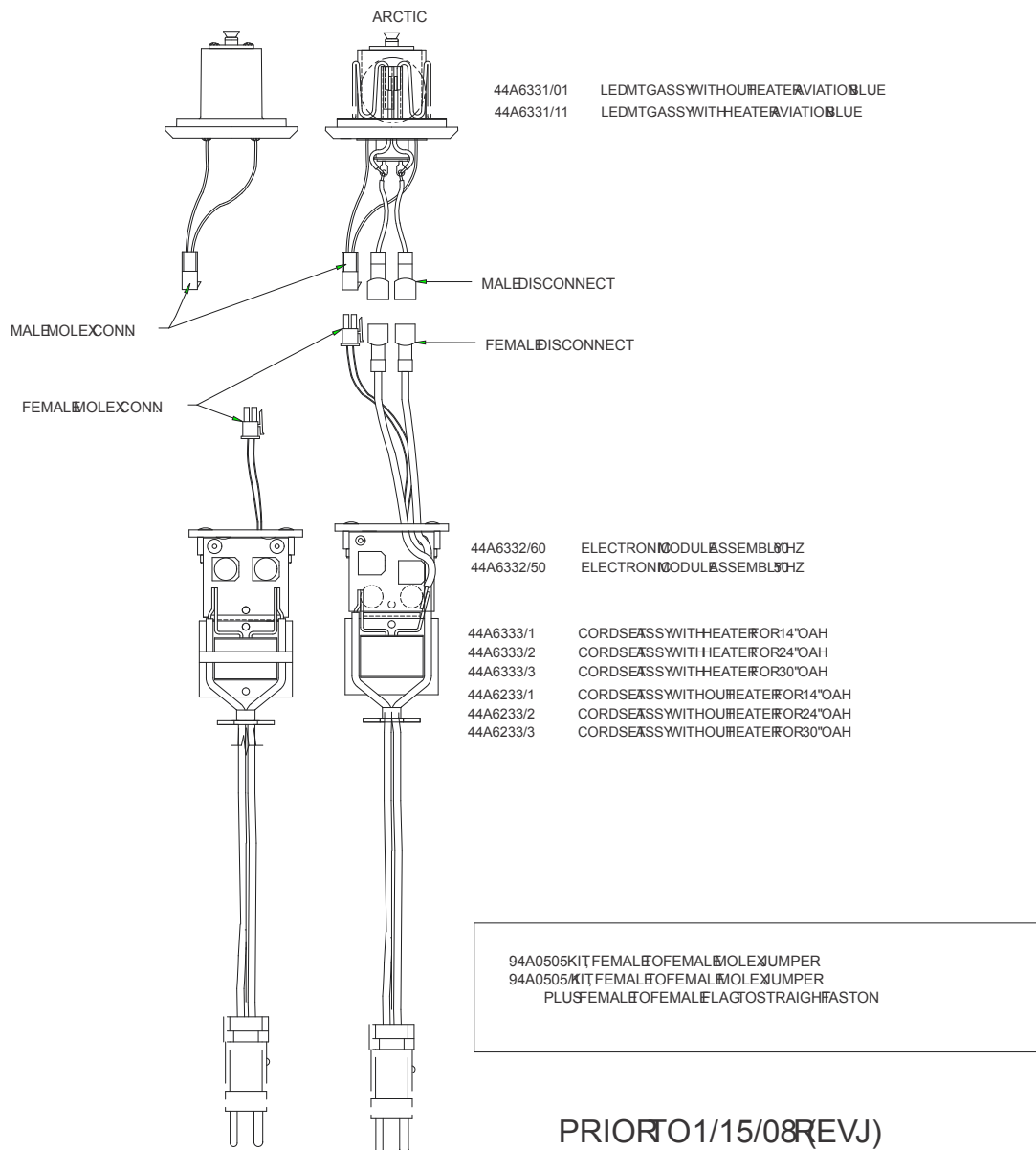

8.3.1 LED Replacement Charts

Table 3: ETES Replacement Chart For ETES/XXXX REV J CHANGE

ETES	Old		Current		Replace old with new	
	PCB	LED MODULE	PCB	LED MODULE		
/1X10 BLUE 60HZ NO ARC	44A6332/60 1W	44A6331/01 1W LED	44A6606	44A7163/010E 1W LED	44A6606 + 94A0505 + 94A0525/XX + 44A6639	44A7163/010E + 94A0523
BLUE 60HZ ARC	44A6332/60	44A6331/11 1W LED	44A6606	44A7163/110E 1W LED	44A6606 + 94A0505/1 + 94A0525/XX	44A7163/110E + 94A0523/1

Table 3: ETES Replacement Chart For ETES/XXXX REV J CHANGE

	Old		Current		Replace old with new	
/1X20 BLUE 50HZ NO ARC	44A6332/50	44A6331/01 1W LED	44A6606	44A7163/010E 1W LED	44A6606 + 94A0505 + 94A0525/XX + 44A6639	44A7163/010E + 94A0523
/1X21 50HZ ARC	44A6332/50	44A6331/11 1W LED	44A6606	44A7163/110E 1W LED	44A6606 + 94A0505/1 94A0525/XX	44A7163/110E + 94A0523/1
/1X30 BLUE 95-264VAC NOARC	44A6477/1/0400	44A6331/01 1W LED	44A6477/1/0400	44A6662/012E 1W LED	DIRECT REPLACEMENT	44A6662/012E
/2X10 RED 60HZ NO ARC	44A6332/60	44A6331/06 1W LED	44A6606	44A6662/060E 1W LED Obsolete	44A6606 + 94A0505 + 94A0525/XX + 44A6639	44A6662/060E + 94A0523
/2X11 RED 60HZ ARC	44A6332/60	44A6331/16 1W LED	44A6606	44A6662/160E 1W LED	44A6606 + 94A0505/1 + 94A0525/XX	44A6662/160E + 94A0523/1
/2X30 RED 95-264VAC NOARC	44A6477/1/0400	44A6662/0610 1W LED	44A6477/1/0400	44A6662/062E 1W LED	DIRECT REPLACEMENT	44A6662/062E
/5X10 YEL 60HZ NO ARC	44A6332/60	44A6331/05 1W LED	44A6606	44A6662/050E 1W LED Obsolete	44A6606 + 94A0505 + 94A0525/XX + 44A6639	44A6662/050E + 94A0523
/5X11 YEL 60HZ ARC	44A6332/60	44A6331/15 1W LED	44A6606	44A6662/150E 1W LED	44A6606 + 94A0505/1 + 94A0525/XX	44A6662/150E + 94A0523/1
/5X30 YEL 95-264VAC NOARC	44A6477/1/0400	44A6662/0510 1W LED	44A6477/1/0400	44A6662/052E 1W LED Obsolete	DIRECT REPLACEMENT	44A6662/052E

Table 4: Replacement Kits

Kit	Description	Notes
94A0505	KIT LED WIRE LEAD F-F	Adapt a 44A6606 PCB to a 44A6331 LED Module no arctic
94A0505/1	KIT LED WIRE LEAD F-F + (2) FLAG terminal TO FASTON HEATER JUMPER F-F	Adapt a 44A6606 PCB to a 44A6331 LED Module with arctic
94A0523	KIT LED WIRE LEAD M-M	Adapt a 44A6662 LED Module to a 44A6332 PCB no arctic
94A0523/1	KIT LED WIRE LEAD M-M + (2) FASTON HEATER JUMPER M-M	Adapt a 44A6662 LED Module to a 44A6332 PCB with arctic
94A0525/XX	L-823 CORD SET FOR 44A6606 POWER SUPPLY /XX for overall height	Use when replacing 44A6332 Power Supply
44A6639	ETES JUMPER ASSEMBLY	Use with 44A6606 Power Supply without arctic kit



Note

Second generation 5W LED Module and 5W PCB Power Supply are no longer available and must be replaced. 5W assemblies: 44A6332/60/5 - 5W PCB Power Supply 44A6331/11/5W - 5W LED Module with Heater

8.4 Spare Parts

Table 5: Spare Parts

Description	Part No.
Column for 14" OAH, 1.5-inch coupling	62A0007-3
Column for 14" OAH, 2-inch coupling	62A0007-2
Column for 24" OAH	62A0007-13
Column for 30" OAH	62A0007-19
Cord set, L-823 3-pin, male, 95-264 VAC	73A0144-31
Cord set, L-823 3-pin, female, 95-264 VAC	73A0145-12
Cord set, L-823, 2-pin, Style 6, current driven (without terminal)	73A0136-31
Cord set assembly, current driven, 14" OAH	44A6835-14
Cord set assembly, current driven, 24" OAH	44A6835-24
Cord set assembly, current driven, 30" OAH	44A6835-30
Frangible coupling, 2 inch, 11.5 TPI <350mm	SP.ASMC00094-002
Frangible coupling, 2 inch, 11 TPI <350mm	SP.ASMC00094-001
Frangible coupling, 1.5 inch, 12 TPI	62B007/SPARE
Frangible coupling, 1.5 inch, 12 TPI, with slot ¹	62B0461/SPARE
Frangible reducer coupling, 2-1 inch, 11.5 TPI	61A0281/SPARE
Frangible reducer coupling, 2-1 inch, 11 TPI	61A0350/SPARE
Gasket, lens bearing	63A1048
Glassware, blue	63A1054-1
Glassware, red	63A1054-2
Glassware, yellow	63A1054-3
Glassware, green	63A1054-5
Glassware, white	63A1117-W
Glassware assembly, blue	44A6334
Glassware assembly, red	44A6334-1
Glassware assembly, yellow	44A6334-3
Glassware assembly, white	44A6334-4
Glassware assembly, green	44A6334-10
Glassware assembly, amber (UV-resist. polycarbonate)	44A6334/13
Glassware assembly, red (UV-resist. polycarbonate)	44A6334/12
Lens (UV resistant polycarbonate), blue	63A1088-B
Lens assembly, blue (UV-resist. polycarbonate)	44A6334-6
Terminal, 90°, for cord set	70A0714
PCB ASSY, ETES LED PS 50/60HZ, W/ BRKT	44A7475-1

¹Slot across threaded end allows easy replacement of broken frangible coupling

Appendix A: SUPPORT

Our experienced engineers are available for support and service at all times, 24 hour/7 days a week. They are part of a dynamic organization making sure the entire ADB SAFEGATE is committed to minimal disturbance for airport operations.

ADB SAFEGATE Support

Technical Support – Global

Customers in Europe, the Middle East, Africa or Asia Pacific are more than welcome to our portal for technical support. Trained in all areas of system issues, troubleshooting, quality control and technical assistance, our highly experienced Technical support specialists are available 24 hours a day, seven days a week to provide assistance over the phone. In the Americas, we also offer live technical support.

Live Technical Support – Americas

If at any time you have a question or concern about your product, contact ADB SAFEGATE's US-based technical support specialists, available 24 hours a day, seven days a week, to assist you via phone.

ADB SAFEGATE Americas Technical Service & Support (US & Canada) :+1-800-545-4157

ADB SAFEGATE Americas Technical Service & Support (Canada): +1-905-631-1597

ADB SAFEGATE Americas Technical Service & Support (International): +1-614-861-1304

We can also be reached via email during regular business hours:

Airfield and Gate: techservice.us@adbsafegate.com

Gate: gateservice.us@adbsafegate.com

We look forward to working with you!

Before You Call

When you have an airfield lighting or system control system problem, prior to calling, please ensure the following:

- Review the product's manual and troubleshooting guide.
- Be located with the product ready to troubleshoot.
- Have all necessary information available: airport code/company name, customer id number, contact phone number/email address, product/part number.
- Have a True RMS meter available and any other necessary tools.

When calling about an issue with Safedock A-VDGS, we can serve you better if you collect the following information before you call:

- Relevant information regarding the issue you are calling about, such as gate number, flight number, aircraft type and time of the event.
- What, if any, actions have been taken to resolve the issue prior to the call.
- If available, provide a CCTV recording of the incident to aid in aligning the information from the Safedock log file.

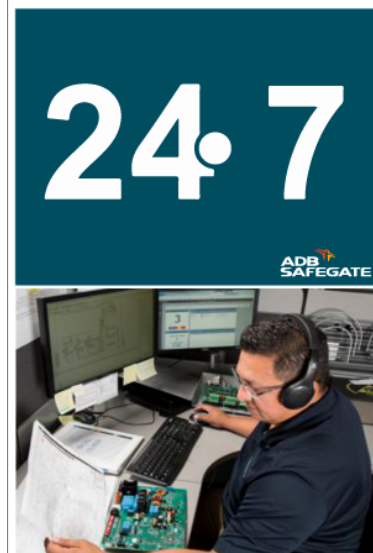

Note

For more information, see www.adbsafegate.com, contact ADB SAFEGATE Support via email at support@adbsafegate.com or

Europe: +32 2 722 17 11

Americas: +1 614 861 1304. Press 3 for technical service or press 4 for sales support.

China: +86 (10) 8476 0106

Middle East and Africa: +971 4 452 7575

A.1 ADB SAFEGATE Website

The ADB SAFEGATE website, www.adbsafegate.com, offers information regarding our airport solutions, products, company, news, links, downloads, references, contacts and more.

A.2 Recycling

A.2.1 Local Authority Recycling

The disposal of ADB SAFEGATE products is to be made at an applicable collection point for the recycling of electrical and electronic equipment. The correct disposal of equipment prevents any potential negative consequences for the environment and human health, which could otherwise be caused by inappropriate waste handling. The recycling of materials helps to conserve natural resources. For more detailed information about recycling of products, contact your local authority city office.

A.2.2 ADB SAFEGATE Recycling

ADB SAFEGATE is fully committed to environmentally-conscious manufacturing with strict monitoring of our own processes as well as supplier components and sub-contractor operations. ADB SAFEGATE offers a recycling program for our products to all customers worldwide, whether or not the products were sold within the European Union (EU).

ADB SAFEGATE products and/or specific electrical and electronic component parts which are fully removed/separated from any customer equipment and returned will be accepted for our recycling program.

All items returned must be clearly labeled as follows:

- For Restriction of Hazardous Substances (RoHS)/Waste Electrical and Electronic Equipment (WEEE) Recycling
- Sender contact information (Name, Business Address, Phone number).
- Main Unit Serial Number.

ADB SAFEGATE will continue to monitor and update according for any future requirements for EU directives as and when EU member states implement new regulations and or amendments. It is our aim to maintain our compliance plan and assist our customers.

WWW.ADBSAFEGATE.COM

Empowering the Airside **Evolution**

SMARTER. BETTER. **NOW.**

