



RELIANCE Inset Lights

8-inch (RC-RZ-RX-TC-SB)

User Manual

UM-0211, Rev. 4.2, 2025/02/04



A.0 Disclaimer / Standard Warranty

CE certification

The equipment listed as CE certified means that the product complies with the essential requirements concerning safety and hygiene. The European directives that have been taken into consideration in the design are available on written request to ADB SAFEGATE.

ETL certification

The equipment listed as ETL certified means that the product complies with the essential requirements concerning safety and C22.2 No.180:13 (R2018) regulations. The CSA directives that have been taken into consideration in the design are available on written request to ADB SAFEGATE.

All Products Guarantee

ADB SAFEGATE will correct by repair or replacement per the applicable guarantee below, at its option, equipment or parts which fail because of mechanical, electrical or physical defects, provided that the goods have been properly handled and stored prior to installation, properly installed and properly operated after installation, and provided further that Buyer gives ADB SAFEGATE written notice of such defects after delivery of the goods to Buyer. Refer to the Safety section for more information on Material Handling Precautions and Storage precautions that must be followed.

ADB SAFEGATE reserves the right to examine goods upon which a claim is made. Said goods must be presented in the same condition as when the defect therein was discovered. ADB SAFEGATE further reserves the right to require the return of such goods to establish any claim.

ADB SAFEGATE's obligation under this guarantee is limited to making repair or replacement within a reasonable time after receipt of such written notice and does not include any other costs such as the cost of removal of defective part, installation of repaired product, labor or consequential damages of any kind, the exclusive remedy being to require such new parts to be furnished.

ADB SAFEGATE's liability under no circumstances will exceed the contract price of goods claimed to be defective. Any returns under this guarantee are to be on a transportation charges prepaid basis. For products not manufactured by, but sold by ADB SAFEGATE, warranty is limited to that extended by the original manufacturer. This is ADB SAFEGATE's sole guarantee and warranty with respect to the goods; there are no express warranties or warranties of fitness for any particular purpose or any implied warranties of fitness for any particular purpose or any implied warranties other than those made expressly herein. All such warranties being expressly disclaimed.

Standard Products Guarantee

Products manufactured by ADB SAFEGATE are guaranteed against mechanical, electrical, and physical defects (excluding lamps) which may occur during proper and normal use for a period of two years from the date of ex-works delivery, and are guaranteed to be merchantable and fit for the ordinary purposes for which such products are made.



Note

See your applicable sales agreement for a complete warranty description.

Replaced or repaired equipment under warranty falls into the warranty of the original delivery. No new warranty period is started for these replaced or repaired products.

FAA Certified products manufactured by ADB SAFEGATE

ADB SAFEGATE L858 Airfield Guidance Signs are warranted against mechanical and physical defects in design or manufacture for a period of 2 years from date of installation, per FAA AC 150/5345-44 (applicable edition).

ADB SAFEGATE LED products (with the exception of obstruction lighting) are warranted against electrical defects in design or manufacture of the LED or LED specific circuitry for a period of 4 years from date of installation, per FAA EB67 (applicable edition). These FAA certified constant current (series) powered LED products must be installed, interfaced and powered with and through products certified under the FAA Airfield Lighting Equipment Program (ALECP) to be included in this 4 (four) year warranty. This includes, but is not limited to, interface with products such as Base Cans, Isolation Transformers, Connectors, Wiring, and Constant Current Regulators.



Note

See your sales order contract for a complete warranty description.

Replaced or repaired equipment under warranty falls into the warranty of the original delivery. No new warranty period is started for these replaced or repaired products.

Liability



WARNING

Use of the equipment in ways other than described in the catalog leaflet and the manual may result in personal injury, death, or property and equipment damage. Use this equipment only as described in the manual.

ADB SAFEGATE cannot be held responsible for injuries or damages resulting from non-standard, unintended uses of its equipment. The equipment is designed and intended only for the purpose described in the manual. Uses not described in the manual are considered unintended uses and may result in serious personal injury, death or property damage.

Unintended uses, includes the following actions:

- Making changes to equipment that have not been recommended or described in this manual or using parts that are not genuine ADB SAFEGATE replacement parts or accessories.
- Failing to make sure that auxiliary equipment complies with approval agency requirements, local codes, and all applicable safety standards if not in contradiction with the general rules.
- Using materials or auxiliary equipment that are inappropriate or incompatible with your ADB SAFEGATE equipment.
- Allowing unskilled personnel to perform any task on or with the equipment.

Copyright Statement

This manual or parts thereof may not be reproduced, stored in a retrieval system, or transmitted, in any form or by any means, electronic, mechanical, photocopying, recording, nor otherwise, without the author's prior written consent.

This manual could contain technical inaccuracies or typographical errors. The author reserves the right to revise this manual from time to time in the contents thereof without obligation of the author to notify any person of such revision or change. Details and values given in this manual are average values and have been compiled with care. They are not binding, however, and the author disclaims any liability for damages or detriments suffered as a result of reliance on the information given herein or the use of products, processes or equipment to which this manual refers. No warranty is made that the use of the information or of the products, processes or equipment to which this manual refers will not infringe any third party's patents or rights. The information given does not release the buyer from making their own experiments and tests.

Table of Contents

1.0 Safety	1
1.1 Safety Messages.....	1
1.1.1 Introduction to Safety	2
1.1.2 Intended Use.....	2
1.1.3 Material Handling Precautions : Storage	3
1.1.4 Operation Safety.....	3
1.1.5 Maintenance Safety	3
1.1.6 Material Handling Precautions: Fasteners	4
1.1.7 Material Handling Precautions, ESD.....	4
2.0 About this Manual	5
2.1 Abbreviations and Terms	5
3.0 Introduction	7
3.1 Product Information.....	7
3.2 Dimensions and Weight	8
4.0 Installation	11
4.1 Unpacking the Unit	11
4.2 Tools Required	11
4.3 Installation and removal of the 8-inch light fixture.....	12
4.4 Toe-in	13
4.5 Light Emission Directions	14
4.5.1 Definition of Light Emission Directions	14
4.5.2 RELIANCE IQ0 and RELIANCE IQ1 Schematic Installation Example	14
4.5.3 8-inch Light Beam Types.....	15
5.0 Operation	17
6.0 Maintenance	19
6.1 Basic Maintenance Program	19
6.2 Workshop Maintenance	20
6.2.1 Open and close an 8-inch Fixture	20
6.2.2 Check the Light Fixture for Water-tightness.....	23
6.2.3 Replace a Light Engine in an 8-inch Fixture.....	23
6.2.4 Replace a Prism and its Gasket in an 8-inch Fixture	24
6.2.5 Replace the Bottom Cover and Converter.....	26
6.2.6 Reset the Fail-Open Converter 2.3	27
6.2.7 Reset the Fail-Open Converter 48010921 and 48011111	28
7.0 Ordering Codes	31
7.1 Ordering Code (RC-RZ-RX).....	31
7.2 Spare Parts (RC-RZ-RX)	31
7.3 Ordering Code (TC).....	33
7.4 Spare Parts (TC)	33
7.5 Ordering Code (SB ICAO).....	36
7.6 Spare Parts (ICAO SB)	36
7.7 Ordering Code (SB FAA).....	38
7.8 Spare Parts (FAA SB)	38
A.0 INTEROPERABILITY	41
B.0 POWER TABLE	45
C.0 CABLE LOSS	51
D.0 SUPPORT	53
D.1 ADB SAFEGATE Website	53
D.2 Recycling	54
D.2.1 Local Authority Recycling	54
D.2.2 ADB SAFEGATE Recycling.....	54

List of Figures

Figure 1: In an 8-in base	11
Figure 2: In a 12-in base with adapter ring	11
Figure 3: Toe-in.....	13
Figure 4: Light emission directions.....	14
Figure 5: Schematic installation example	15
Figure 6: Fixture upside down.....	21
Figure 7: Lift up housing	21
Figure 8: Remove gasket	21
Figure 9: Converter with 1 connector	22
Figure 10: Converter with 2 connectors	22
Figure 11: Fixture facing down.....	22
Figure 12: Tighten screws	22
Figure 13: Remove the LED board holder.....	23
Figure 14: Tighten screws	24
Figure 15: LED board	24
Figure 16: Remove LED board holder	24
Figure 17: Remove prism and gasket.....	24
Figure 18: New prism into prism gasket.....	25
Figure 19: Prism holder edge	25
Figure 20: Tighten screws in sequence.....	26
Figure 21: Gasket	27
Figure 22: Converter with 1 connector	27
Figure 23: Converter with 2 connectors	27
Figure 24: 2-way electrical shunt/jumper	27
Figure 25: Converter with 1 connector	28
Figure 26: Converter with 2 connectors	28
Figure 27: Converter with 1 connector	29
Figure 28: Converter with 2 connectors	29
Figure 29: Top cover versions	41
Figure 30: Shallow bases.....	42

List of Tables

Table 1: Bidirectional light beam.....	15
Table 2: Unidirectional light beam	15
Table 3: Maintenance tasks.....	19
Table 4: Manufactured before 2018-06 version 1	41
Table 5: Manufactured after 2018-06 version 2 and 3	42
Table 6: Interoperability matrix	43

1.0 Safety

Introduction to Safety







This section contains general safety instructions for installing and using ADB SAFEGATE equipment. Some safety instructions may not apply to the equipment in this manual. Task- and equipment-specific warnings are included in other sections of this manual where appropriate.

1.1 Safety Messages

HAZARD Icons used in the manual

For all HAZARD symbols in use, see the Safety section. All symbols must comply with ISO and ANSI standards.

Carefully read and observe all safety instructions in this manual, which alert you to safety hazards and conditions that may result in personal injury, death or property and equipment damage and are accompanied by the symbol shown below.

	<p>WARNING Failure to observe a warning may result in personal injury, death or equipment damage.</p>
	<p>DANGER – Risk of electrical shock or ARC FLASH Disconnect equipment from line voltage. Failure to observe this warning may result in personal injury, death, or equipment damage. ARC Flash may cause blindness, severe burns or death.</p>
	<p>WARNING – Wear personal protective equipment Failure to observe may result in serious injury.</p>
	<p>WARNING – Do not touch Failure to observe this warning may result in personal injury, death, or equipment damage.</p>
	<p>CAUTION Failure to observe a caution may result in equipment damage.</p>
	<p>ELECTROSTATIC SENSITIVE DEVICES This equipment may contain electrostatic devices.</p>

Qualified Personnel

	<p>Important Information The term qualified personnel is defined here as individuals who thoroughly understand the equipment and its safe operation, maintenance and repair. Qualified personnel are physically capable of performing the required tasks, familiar with all relevant safety rules and regulations and have been trained to safely install, operate, maintain and repair the equipment. It is the responsibility of the company operating this equipment to ensure that its personnel meet these requirements. Always use required personal protective equipment (PPE) and follow safe electrical work practice.</p>
-------------------------------------------------------------------------------------	----------------------------------------------------------------------------------------------------------------------------------------------------------------------------------------------------------------------------------------------------------------------------------------------------------------------------------------------------------------------------------------------------------------------------------------------------------------------------------------------------------------------------------------------------------------------------------------------------------------------------------------------------------------

1.1.1 Introduction to Safety



CAUTION

Unsafe Equipment Use

This equipment may contain electrostatic devices, hazardous voltages and sharp edges on components

- Read installation instructions in their entirety before starting installation.
- Become familiar with the general safety instructions in this section of the manual before installing, operating, maintaining or repairing this equipment.
- Read and carefully follow the instructions throughout this manual for performing specific tasks and working with specific equipment.
- Make this manual available to personnel installing, operating, maintaining or repairing this equipment.
- Follow all applicable safety procedures required by your company, industry standards and government or other regulatory agencies.
- Install all electrical connections to local code.
- Use only electrical wire of sufficient gauge and insulation to handle the rated current demand. All wiring must meet local codes.
- Route electrical wiring along a protected path. Make sure they will not be damaged by moving equipment.
- Protect components from damage, wear, and harsh environment conditions.
- Allow ample room for maintenance, panel accessibility, and cover removal.
- Protect equipment with safety devices as specified by applicable safety regulations
- If safety devices must be removed for installation, install them immediately after the work is completed and check them for proper functioning prior to returning power to the circuit.

Failure to follow this instruction can result in serious injury or equipment damage

Additional Reference Materials



Important Information

- IEC – International Standards and Conformity Assessment for all electrical, electronic and related technologies.
- IEC 60364 – Electrical Installations in Buildings.
- CSA – C22.2 No.180:13 (R2018), series isolating transformers for airport lighting.
- FAA Advisory: AC 150/5340-26 (current edition), Maintenance of Airport Visual Aid Facilities.
- Maintenance personnel must refer to the maintenance procedure described in the ICAO Airport Services Manual, Part 9.
- ANSI/NFPA 79, Electrical Standards for Metalworking Machine Tools.
- National and local electrical codes and standards.

1.1.2 Intended Use



CAUTION

Use this equipment as intended by the manufacturer

This equipment is designed to perform a specific function, do not use this equipment for other purposes

- Using this equipment in ways other than described in this manual may result in personal injury, death or property and equipment damage. Use this equipment only as described in this manual.

Failure to follow this instruction can result in serious injury or equipment damage

1.1.3 Material Handling Precautions : Storage



CAUTION

Improper Storage

Store this equipment properly

- If equipment is to be stored prior to installation, it must be protected from the weather and kept free of condensation and dust.

Failure to follow this instruction can result in equipment damage

1.1.4 Operation Safety



CAUTION

Improper Operation

Do Not Operate this equipment other than as specified by the manufacturer

- Only qualified personnel, physically capable of operating the equipment and with no impairments in their judgment or reaction times, should operate this equipment.
- Read all system component manuals before operating this equipment. A thorough understanding of system components and their operation will help you operate the system safely and efficiently.
- Before starting this equipment, check all safety interlocks, fire-detection systems, and protective devices such as panels and covers. Make sure all devices are fully functional. Do not operate the system if these devices are not working properly. Do not deactivate or bypass automatic safety interlocks or locked-out electrical disconnects or pneumatic valves.
- Protect equipment with safety devices as specified by applicable safety regulations.
- If safety devices must be removed for installation, install them immediately after the work is completed and check them for proper functioning.
- Route electrical wiring along a protected path. Make sure they will not be damaged by moving equipment.
- Never operate equipment with a known malfunction.
- Do not attempt to operate or service electrical equipment if standing water is present.
- Use this equipment only in the environments for which it is rated. Do not operate this equipment in humid, flammable, or explosive environments unless it has been rated for safe operation in these environments.
- Never touch exposed electrical connections on equipment while the power is ON.

Failure to follow these instructions can result in equipment damage

1.1.5 Maintenance Safety



DANGER

ELECTRIC SHOCK HAZARD

THIS EQUIPMENT MAY CONTAIN ELECTROSTATIC DEVICES

- DO NOT OPERATE A SYSTEM THAT CONTAINS MALFUNCTIONING COMPONENTS. IF A COMPONENT MALFUNCTIONS, TURN THE SYSTEM OFF IMMEDIATELY.
- DISCONNECT AND LOCK OUT ELECTRICAL POWER.
- ALLOW ONLY QUALIFIED PERSONNEL TO MAKE REPAIRS. REPAIR OR REPLACE THE MALFUNCTIONING COMPONENT ACCORDING TO INSTRUCTIONS PROVIDED IN ITS MANUAL.

FAILURE TO FOLLOW THESE INSTRUCTIONS CAN RESULT IN DEATH OR EQUIPMENT DAMAGE

1.1.6 Material Handling Precautions: Fasteners



DANGER

FOREIGN OBJECT DAMAGE - FOD

THIS EQUIPMENT MAY CONTAIN FASTENERS THAT MAY COME LOOSE - TORQUE PROPERLY.

- ONLY USE FASTENERS OF THE SAME TYPE AS THE ONE ORIGINALLY SUPPLIED WITH THE EQUIPMENT.
- USE OF INCORRECT COMBINATION OF GASKETS, BOLTS AND NUTS CAN CREATE SEVERE DAMAGES TO THE PRODUCT INSTALLATION AND CREATE SAFETY RISK .
- YOU NEED TO KNOW WHAT BASE THE LIGHT FIXTURE WILL BE INSTALLED IN, IN ORDER TO CHOSE THE CORRECT GASKET, BOLTS AND NUTS.
- BOLT TYPE, LENGTH, AND TORQUE VALUE ARE DETERMINED BY TYPE OF BASE, HEIGHT OF SPACERS USED, AND CLAMP FORCE REQUIRED IN FAA ENGINEERING BRIEF NO 83 (LATEST REVISION).
- DUE TO THE RISK OF BOLTS VIBRATING LOOSE, DO NOT USE ANY TYPE OF WASHER WITH THE FIXING BOLTS (SUCH AS SPLIT LOCK WASHERS) OTHER THAN AN ANTI-VIBRATION WASHER. ANTI-VIBRATION WASHERS AS DEFINED IN FAA EB 83 (LATEST EDITION) MUST BE USED. FOR INSTALLATIONS OTHER THAN FAA, USE THE BASE CAN MANUFACTURER'S RECOMMENDATIONS.
- ALWAYS TIGHTEN THE FASTENERS TO THE RECOMMENDED TORQUE. USE A CALIBRATED TORQUE WRENCH AND APPLY THE RECOMMENDED ADHESIVE TYPE.
- OBEY THE INSTRUCTIONS OF THE ADHESIVES NECESSARY FOR THE FASTENERS.

FAILURE TO FOLLOW THESE WARNINGS MAY CAUSE THE FASTENERS TO LOOSEN, DAMAGE THE EQUIPMENT, POTENTIALLY TO LOOSEN THE EQUIPMENT. THIS CAN LEAD TO A HIGHLY DANGEROUS SITUATION OF FOD, WITH POTENTIAL LETHAL CONSEQUENCES.



Note

To minimize the risk of errors, the ADB SAFEGATE Sales Representative will have information on which gasket goes with which base. This information is also provided in the product Data sheets, the User Manuals and the Spare Part Lists.



CAUTION

Use of incorrect combination of gaskets, bolts and nuts can create severe damages to the product installation and create multiple safety risks.

To obtain a safe and watertight installation the O - ring and retaining bolt stated in the document must be used.

You need to know what base the light fixture will be installed in, in order to choose the correct gasket, bolts and nuts.

Failure to follow these cautions can result in equipment damage or aircraft FOD.

1.1.7 Material Handling Precautions, ESD



CAUTION

Electrostatic Sensitive Devices

This equipment may contain electrostatic devices

- Protect from electrostatic discharge.
- Electronic modules and components should be touched only when this is unavoidable e.g. soldering, replacement.
- Before touching any component of the cabinet you shall bring your body to the same potential as the cabinet by touching a conductive earthed part of the cabinet.
- Electronic modules or components must not be brought in contact with highly insulating materials such as plastic sheets, synthetic fiber clothing. They must be laid down on conductive surfaces.
- The tip of the soldering iron must be grounded.
- Electronic modules and components must be stored and transported in conductive packing.

Failure to follow this instruction can result in equipment damage

2.0 About this Manual

This document includes RELIANCE™ inset light fixture information with a focus on safety, installation and maintenance procedures.

For more information, see www.adbsafegate.com.



Note

It is very important to read this document before any work is started.

This manual covers the following RELIANCE fixtures:

- Runway Centerline
- Touchdown Zone
- Runway Edge 45 m
- ICAO Stop Bar
- Taxiway Centerline Narrow
- Taxiway Centerline Curved
- Enhanced Taxiway Centerline for Rapid Exit
- Taxiway Centerline Wide

2.1 Abbreviations and Terms

This document may include the abbreviations and terms listed below.

Abbreviation and term	Description
A-SMGCS	Advanced Surface Movement Guidance and Control System
CAA	Civil Aviation Authority
CCR	Constant Current Regulator
FAA	Federal Aviation Administration
ICAO	International Civil Aviation Organization
IEC	International Electrotechnical Committee
ILCMS	Individual Light Control and Monitoring System
LED	Light Emitting Diode
NATO	North Atlantic Treaty Organization
SMGCS	Surface Movement Guidance and Control System
SSU	System Switch Unit
STAC	Service Technique de l'Aviation Civile (France)
STANAG	Standardization Agreement (NATO)

3.0 Introduction

RELIANCE - the all in one revolution

The RELIANCE inset light is a bi- or unidirectional low protrusion light-emitting diode (LED) fixture, available in three versions:

<p>RELIANCE A LED light fixture with integrated fail open technology with CCR monitoring compatibility</p> <p>RELIANCE IQ A RELIANCE with additional and integrated intelligence (IQ) in a built-in converter for individual monitoring and control, based on RELIANCE Intelligent Light Control and Monitor System (ILCMS)</p> <p>RELIANCE IQ0 RELIANCE IQ light fixture with disabled IQ (ILCMS) functionality. Non-MON light fixture with possibility to activate IQ at a later stage</p>	
-------------------------------------------------------------------------------------------------------------------------------------------------------------------------------------------------------------------------------------------------------------------------------------------------------------------------------------------------------------------------------------------------------------------------------------------------------------------------------------------------------------------------------	--



Note

RELIANCE IQ light fixtures are not fail-open light fixtures. When IQ is activated the monitoring as well as the control functionality is handled by the ILCMS system.

3.1 Product Information

Compliance and Standards

Compliance	Description	Application:	LS-RC	RE	RT	AS-AC
		Reference DS-XXXX:	7002	7003	7004	7006
FAA	AC 150/5345-46 and the FAA Engineering Brief No. 67					
ICAO	Annex 14 Volume 1		X	X	X	X
EASA	CS-ADR-DSN		X	X	X	X
Australia	MOS 139		X	X	X	X
Canada	TP 312		X	X	X	X
IEC	61827		X	X	X	X
NATO	STANAG 3316		X	X	X	X
STAC	PRO/STAC/SE/VIS		X	X	X	X
CE			X	X	X	X

Features and Benefits

Efficiency

- Available in three versions:
 - RELIANCE™ IQ with integrated intelligence
 - RELIANCE with integrated fail-open (Mon) technology. Fuse resistors are part of the Mon-functionality and spares needs to be ordered separately.
 - RELIANCE Non-MON, non-monitored lights
- Light Emitting Diode (LED) technology that offers a long-lasting light source with low power consumption
- Compatibility between RELIANCE IQ version and RELIANCE Intelligent Lighting 2A system for further power savings and ILCMS

- No visual flicker. PWM is used for some applications to optimize the LED performance and light fixtures show no visual flickering.

Sustainability

- Fully encapsulated all-in-one electronics
- IP68 protected, aluminum housing designed for harsh weather environments, all fastenings in stainless steel
- Reinforced prism available as an option
- Operates on 3- or 5-step ferroresonant or thyristor CCRs designed in compliance with IEC or FAA requirements
- Easy handling and maintenance by modular design with few mechanical parts
- Compatible with existing infrastructure

Safety

- Built-in voltage surge and lightning protection
- Fully dimmable lights, respecting the response curve of traditional halogen lights
- Low protrusion, high-intensity, Style 3 inset light fixtures
- No negative slope in front of the prisms

Power Supply

An integrated, encapsulated 6.6A electronic converter. One or two pin L-823 plugs for connection to the transformer(s). . Power factor typically >0.9 at 6.6A.

Refer to the user manual for the 8-inch or 12-inch RELIANCE inset lights and the complete power table and cable loss formula.

Maintenance and Installation

The light fixture can be installed in an 8-inch or 12-inch base. Gaskets are sold separately. Check what gasket and bolts to order depending on base and installation.

Refer to the user manual for the 8-inch or 12-inch RELIANCE lights and to the interoperability information for installation in a specific base.

Operating Conditions

Operating temperature	-60 °C to +55 °C / -76 °F to +131 °F
Storage temperature	-60 °C to +80 °C / -76 °F to +176 °F
Humidity	Up to 100%

3.2 Dimensions and Weight

Version	Weight Dimension A
RC, RZ, SB, TC, TK, TR, TW	3.0 kg / 203 mm / 8-in 6.6 lb (8 in)
RE 45 m	6.8 kg / 305 mm (12 in) 15 lb (12 in)

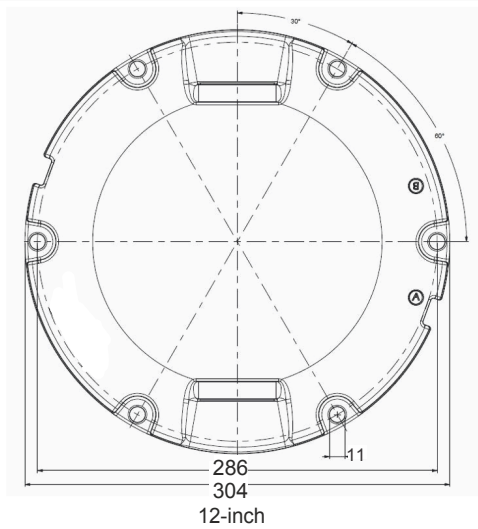
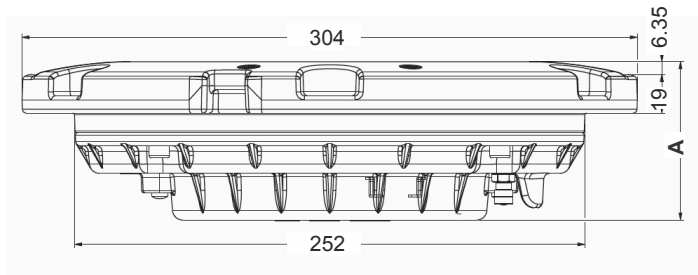
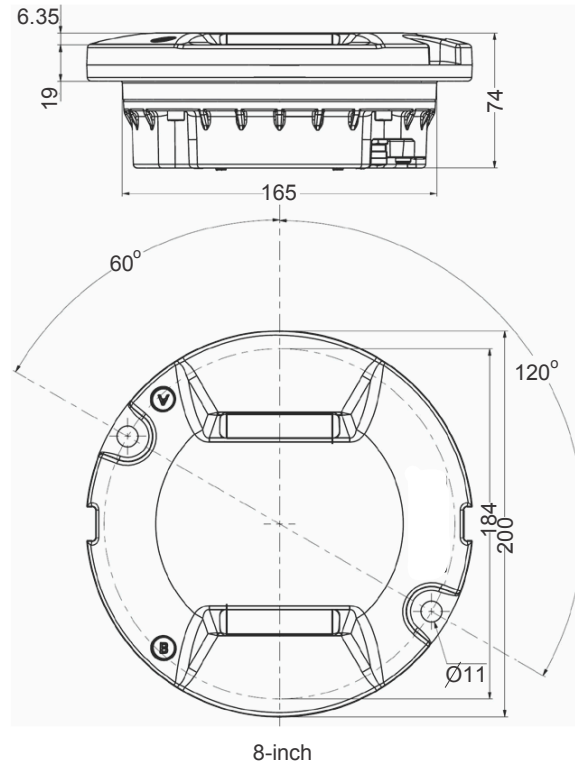

4.0 Installation

Install the inset light fixture in a base provided by ADB SAFEGATE as follows:

Figure 1: In an 8-in base

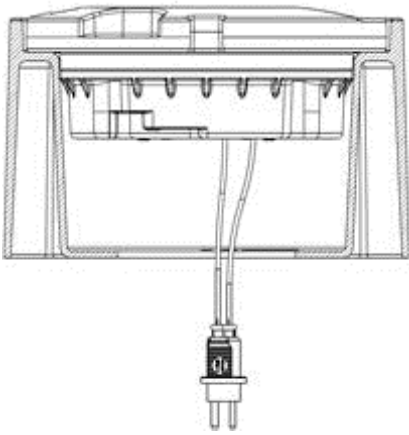
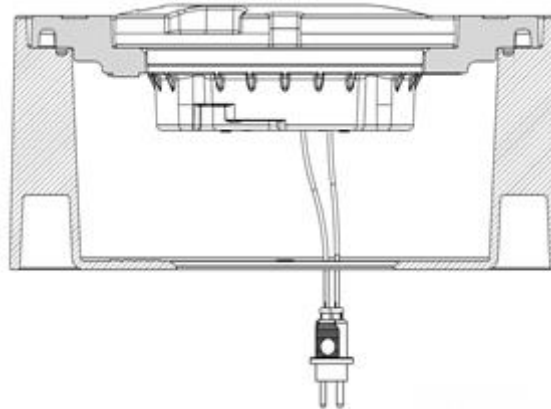

Figure 2: In a 12-in base with adapter ring



Note

If the inset light fixture is to be installed on another type of base or adapter ring not provided by ADB SAFEGATE, contact ADB SAFEGATE. The inset light fixture is fixed in the base by six M10 lock nuts or by six M10×25 or M10×22 bolts dependent on base installation.



CAUTION

Use of incorrect combination of gaskets, bolts and nuts can create severe damages to the product installation and create multiple safety risks.

To obtain a safe and watertight installation the O - ring and retaining bolt stated in the document must be used.

You need to know what base the light fixture will be installed in, in order to choose the correct gasket, bolts and nuts.

4.1 Unpacking the Unit

To reduce the possibility of damaging the light assembly, unpack the light fixtures at the installation site. If damage to any equipment is noted, file a claim form with the carrier immediately.

When receiving the light fixture, open the box and verify that the characteristics of the light fixture correspond to the design requirements, such as type, color etc. When installing a light fixture where the control and monitoring function is to be activated at a later stage, make sure to register product information, such as PID/SN and position of the light fixture in, for example, a site documentation table. The information is required for remote activation and administration of control and monitoring functionality from a substation.

4.2 Tools Required

The following tools are recommended for installation:

- One Box spanner 16/17 mm
- One torque wrench with a 16/17 mm socket
- Two large flat headed screwdrivers for lifting the light fixture
- One T20 Torx key
- One brush or cloth



NOTICE

Provided that the base intended to receive the light fixture has been properly installed, no other specific tool is required.

4.3 Installation and removal of the 8-inch light fixture

Install the light fixture in a base

Installation instructions for the inset light fixtures as follows:

- Light bases shall be installed with care to assure vertical and azimuth alignment of fixture.
- Provide 60–90 cm / 2–3-foot cable slack within light base to allow transformer servicing.
- The minimum thread engagement into top flange of base is 0.5-inch.
- As required to maintain +0/ through -1/16-inch below grade FAA installation tolerance, a maximum of three spacer rings may be stacked together.

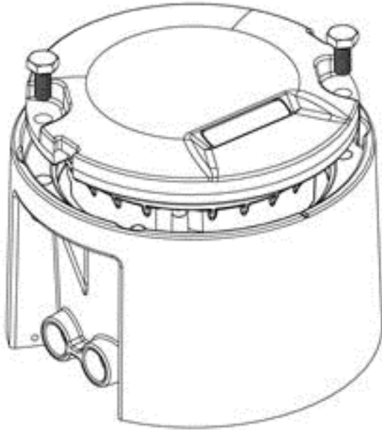

1. Carefully clean all contact surfaces of the light fixture and the base.
2. Put the O-ring gasket in the gasket track on the base.
3. Connect the connector(s) of the light fixture to the base supply cable(s). Check that the A- and B-side are connected to corresponding circuit if two connectors are used.
4. Place the connector under the light fixture and install on the base.
5. For an installation on bases, use a torque limiting box spanner of 16/17 mm, install and tighten the two fixing bolts or nuts to a torque value according to specification, see [INTEROPERABILITY](#). For other base manufacturers, refer to their specifications.



Note

Do not use high speed for tightening. The recommended speed is 10 - 40 rpm. Do not use an impact driver/wrench.

6. After installation, check that each light fixture functions properly.
7. In order to bond the light fixture to ground, use the a screw (Torx M4×6 mm, Torque 2.5 Nm) to attach the braided ground strap to the grounding point on the light fixture. The grounding point is indicated by a grounding symbol and located on the bottom side.

Remove the fitting from the base



CAUTION

Fall- and trip hazard! When a light fixture has been removed, the base must be fitted with a cover designed for this purpose or with a spare light fixture.

1. Using two large flat blade screwdrivers carefully remove the light fixture from its base .
2. Disconnect the secondary supply connector.
3. Remove and check the gasket (O-ring or labyrinth).



Note

It is recommended to change the gasket, lock nuts or bolts each time the light fixture is removed or dismantled from the base. For more information, see [INTEROPERABILITY](#).



CAUTION

Use of incorrect combination of gaskets, bolts and nuts can create severe damages to the product installation and create multiple safety risks.

Verify what base the light fixture will be installed in, in order to chose the correct gasket, bolts and nuts.

Failure to follow these cautions can result in equipment damage or aircraft FOD. For more information, see [INTEROPERABILITY](#).

4.4 Toe-in

Toe-in of light fixtures can be achieved in two ways:

1. By installing the light fixture in runway/taxiway parallel bases and use light fixtures with built in toe-in.
2. By installing the light fixture in bases installed at an angle relative the runway/taxiway and use light fixtures with no built in toe-in.

If bases which are installed at an angle are used, provided that they are installed correctly, straight light fixtures (i.e. with no toe-in) should be used.

The following chapter only regards the case where light fixtures are installed in runway/taxiway parallel bases, i.e. where no toe-in is achieved by angled bases.

There are three major categories regarding the toe-in in light fixtures:

Straight light fixtures	These light fixtures have a straight light beam
Light fixtures with optical toe-in	These light fixtures have a reflector that reflects the light beam at an appropriate angle
Light fixtures with mechanical toe-in	These light fixtures are installed at an angle with in its base due to the hole pattern for the base screws. This results in an angled light beam relative to the runway/taxiway.

Figure 3: Toe-in

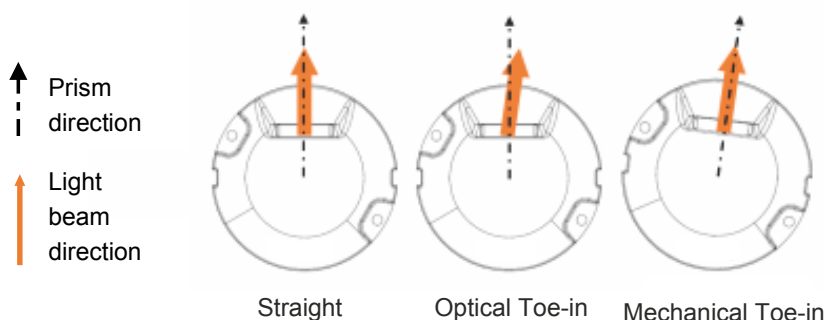

The table below shows a summary of the light fixture types and their toe-in properties.

Light Fixture	Toe-in options	Toe-in type
L-850A(L) - Runway Centreline (RC-I)	Straight	N/A
L-850B(L) - Runway Touchdown Zone (RZ-I)	Straight or Toe-in $\pm 4^\circ$	Mechanical
Rapid Exit Taxiway Indicator (RX-I)	Straight	N/A
L-852C(L) - Taxiway Centreline Narrow (TC-I)	Straight	N/A
L-852K(L) - Taxiway Centreline Curve (TC-I)	$\pm 15.75^\circ$	Optical
Taxiway Centreline Wide (TC-I)	Straight	N/A
L-852D(L) - Taxiway Centreline/Lead-On (TC-I)	Straight	N/A
L-852S(L) & ICAO Stop Bar (SB-I)	Straight or Toe-in $\pm 15.75^\circ$	Optical

4.5 Light Emission Directions

4.5.1 Definition of Light Emission Directions

Light fixtures that have a toe-in are marked with an arrow to ensure a correct installation with regard towards the toe-in. The light fixtures should be installed with the arrow pointing towards the centerline.

The color and direction of the emitted light is indicated with a coloured dot on the top cover in front of the prism. On angled lines the light beam is emitted in the direction of the line. Sides with a straight line have a straight light beam.

The bidirectional light fixtures are all marked with 1 and 2 direction on the top cover and also on the outside of the bottom cover. This is to help orienting the top during installation and to keep track of the color and direction of each side.

Figure 4: Light emission directions

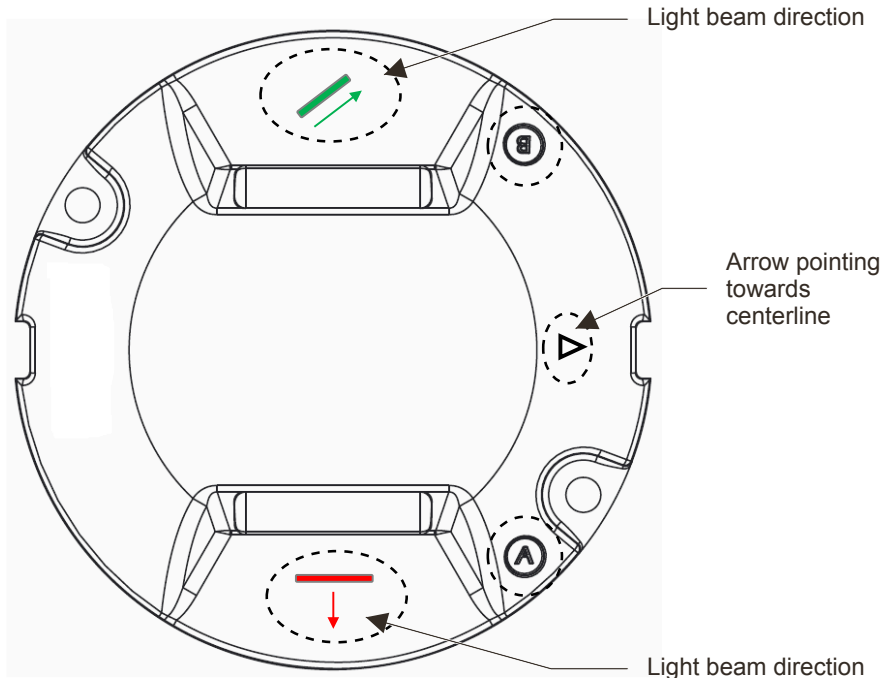

4.5.2 RELIANCE IQ0 and RELIANCE IQ1 Schematic Installation Example

It is important to keep track of the positioning of the RELIANCE IQ0 and RELIANCE IQ1 light fixtures in the bases in order to program the RELIANCE Intelligent Lighting parameters correctly.

Figure 5: Schematic installation example

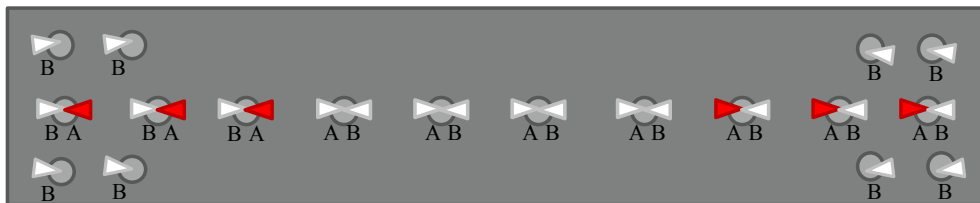

4.5.3 8-inch Light Beam Types

The inset Taxiway centerline and Stop Bar light fixtures have different light beam characteristics depending on application. The light beam can be narrow, wide or curved. The drawings below show the different types of light beam, which correspond to the different type of fitting.



Note

In order to assist with the installation of the fitting in its base in curved sections, make sure that the top of the fitting marked with an arrow always point to the center of the curve.

Table 1: Bidirectional light beam

STRAIGHT			TOE-IN
Narrow	Wide	Wide	Curved
ICAO Fig A2-13	ICAO Fig A2-12		
FAA L852C(L)		FAA L852D(L)	FAA L852K(L)

Table 2: Unidirectional light beam

STRAIGHT			TOE-IN	
Narrow	Wide	Wide	Curved	
ICAO Fig A2-13	ICAO Fig A2-12			
FAA L852C(L)		FAA L852D(L), L-852S(L)	FAA L852K(L)	
			Right	Left

5.0 Operation



Note

Refer to the UM-0600 and other documentation related to RELIANCE IL I and listed with ordering numbers in Data sheet DS-0600 for further info.

6.0 Maintenance

This section describes different steps for maintenance of the light fixture.

Before you start, make sure you have read and understand [Safety instructions](#).

Find out the location of the light unit that needs maintenance. If the purpose is to replace an existing light unit with new one, make sure that corresponding unit is available. Find the type information on the identification tag with details of name.

Spare parts are available, if required. For more information, see www.adbsafegate.com and the Spare Parts List document, or contact ADB SAFEGATE for assistance.



CAUTION

Use of incorrect combination of gaskets, bolts and nuts can create severe damages to the product installation and create multiple safety risks.

You need to know what base the light fixture will be installed in, in order to choose the correct gasket, bolts and nuts.

Failure to follow these cautions can result in equipment damage or aircraft FOD. For more information, see [INTEROPERABILITY](#).



CAUTION

When a light fixture has been removed from its base, the base must be either fitted with a cover or a spare light fixture put in its place. It is recommended that only authorized personnel disassemble fittings with prior agreement from ADB SAFEGATE.

6.1 Basic Maintenance Program

There are recommended maintenance tasks to ensure that the equipment is in correct operating condition.

Table 3: Maintenance tasks

Weekly	<ul style="list-style-type: none"> ▪ Visual inspection of the light fixture. ▪ Removal of dust from external surfaces of the light fixture.
Monthly	<ul style="list-style-type: none"> ▪ Check of the optical window, check for mechanical damage. ▪ Check for proper fixing of the light fixture in its base.
Yearly	<ul style="list-style-type: none"> ▪ Detailed inspection of the light fixture. ▪ Check of the body resistance, check for mechanical damage (for example cracks around prism windows). ▪ Clean of the optical windows.

A daily function check is referred to in the document:

ICAO, Airport Services Manual Part 9, Airport Maintenance Practice and FAA AC 150/5340-26A, Maintenance of airport visual aids facilities.

The light fixture is designed for outdoor operation, however storing the light fixture outside without using it is a risk for damage to light fixture components. For a longer storage time (more than a week), it is recommended to store the light fixture indoors in a dry and dust free environment and at room temperature. Proper storage ensures trouble free replacement procedures. It is strongly recommended not to store any electrical equipment outside.

6.2 Workshop Maintenance



CAUTION

Before you start, make sure you have read and understand [Safety instructions](#).

The following standard tools and accessories are required for maintenance of the unit:

- One angled socket spanner of 16 or 17 mm¹
 - One Torque limiting spanner with 16 or 17 mm socket
 - One hexagonal key (Allen key) of 3, 4, and 5 mm
 - Torx 10, 20, 25, and 30
 - Two large flat blade screwdrivers
 - Silicone grease
 - CC-Patron grease
 - One brush or cloth
 - Non-alcohol based cleaner
-



Note

A compressor, or a manual car tire pump, equipped with a manometer is required to check the light fixture for water-tightness. Design may differ from picture depending on application. Please follow described work flow and torque level specified as they are generic.

The workshop maintenance refers to following:

1. Replace a light fixture
2. Check the light fixture for water-tightness
3. Replace a light engine
4. Replace a prism and its gasket
5. Replace the bottom cover and converter
6. Reset the fail-open converter

6.2.1 Open and close an 8-inch Fixture

Remove

1. Place the light fixture upside down and remove the four screws for the bottom cover using an Allen key 4 mm, see [Figure 6](#).
 2. Lift up the housing and disconnect the LED board cable connector from the LED boards in the top cover, see [Figure 7](#).
-



Note

Open the light fixture cautiously, be careful not to damage the LED-board cables.

3. Remove the bottom cover from the top cover.

1. Depending on type and size of nuts and bolts

- Remove the O-ring gasket from the bottom cover, see [Figure 8](#).

Figure 6: Fixture upside down

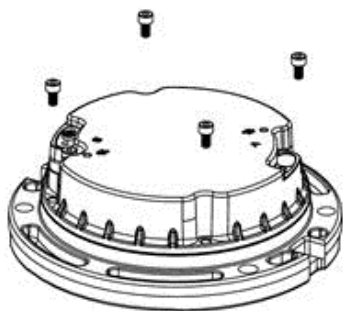

Figure 7: Lift up housing

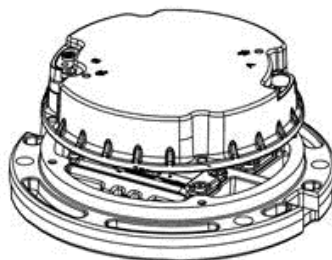
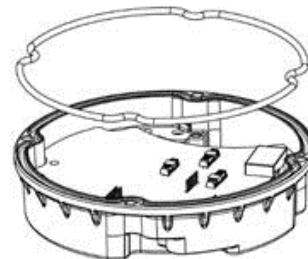

Figure 8: Remove gasket



Replace

1. Carefully clean all contact surfaces of the light fixture and of the housing.
2. Install a new O-ring gasket on the bottom cover.



Note

The O-ring gasket must be changed each time the light fixture is disassembled.

3. Connect the LED board cable connector(s) to the Supply Terminal(s) of the converter in the housing. Note the orientation and alignment of the LED board cables, which are different between 1 connector and 2 connector versions.

Converters with 1 connector: The cables should have colored wires towards each other and crossed.

Converters with 2 connectors: The cables should have colored wires away from each other and crossed. Light fixtures with only one LED-board need to have its LED-board connected to the LED B channel, see [Figure 9](#). Place the top cover over the bottom cover, align 1 and 2 sides on the top cover with the corresponding sides on the bottom cover.

Figure 9: Converter with 1 connector

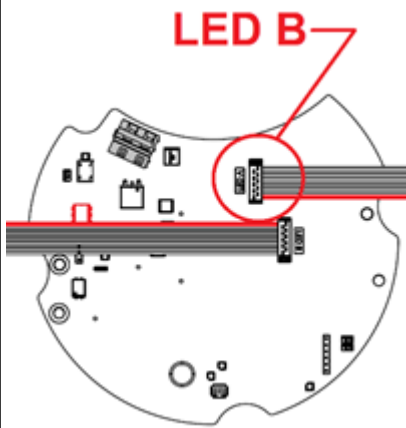
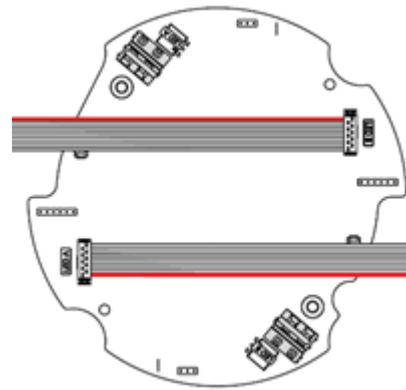

Figure 10: Converter with 2 connectors



Note

Before closing the light fixture, it is important to make sure the O-ring gasket is placed correctly in the groove of the bottom cover to prepare the light fixture for water tightness checks and use in the airfield.

4. Put the light fixture on a surface with the top cover facing down, see [Figure 11](#).
5. Tighten the four screws using a torque limiting spanner 4 mm Allen key to a torque of 8 Nm (equivalent to 0.8 kg m or 8 g.cm), see [Figure 12](#).

Figure 11: Fixture facing down

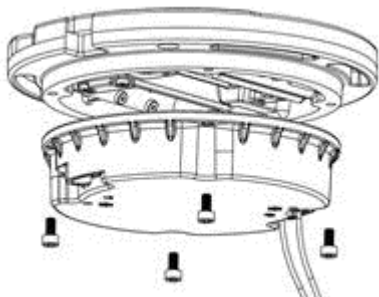
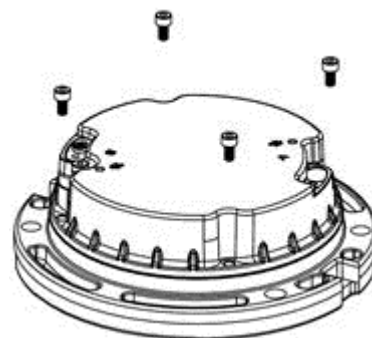

Figure 12: Tighten screws



6. Check the light fixture for water-tightness. For more information, see [Checking the Light Fixture for Water-Tightness](#).

6.2.2 Check the Light Fixture for Water-tightness

If maintenance is carried out in a workshop, check the water-tightness of the light.

Prepare

1. Remove the water-tightness test valve cap.
2. Fill up the light fixture with compressed air (test pressure = 130 kPa).

Test

1. Put the light fixture in water, wait 3 minutes and check if air leaks out of the light.
 - a. If air leaks out of the light fixture (between bottom cover and top plate or between prism and top plate or water-tightness valve and top plate), the light fixture is not watertight and must be repaired. Release the air from the light. Disassemble the light fixture and re-check the mating surfaces and gaskets. Assemble the light fixture and perform the water-tightness test again.
 - b. If the light fixture is water tight, release the compressed air from the light fixture and assemble the cap on the test valve.
2. The light fixture is ready to be reinstalled in the field.



DANGER

NEVER EXCEED PRESSURE OF 150 KPA INSIDE THE LIGHT FIXTURE AS THIS MAY LEAD TO PERSONAL INJURIES AND DAMAGE THE LIGHT.

6.2.3 Replace a Light Engine in an 8-inch Fixture

Remove

1. Disassemble the light fixture.
2. Detach and remove the LED board holder, including 4 screws from the body, using a 3 mm Allen key, see [Figure 13](#).

Figure 13: Remove the LED board holder

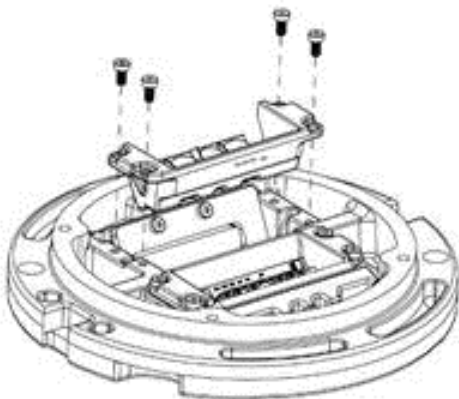

Replace

1. Attach the new LED board holder, including screws. The screws on the LED holder shall be tightened gently in sequence, following number 1-4, see [Figure 14](#).
2. Tighten the same screws to a torque of 4.5 Nm, following number 5-8, see [Figure 14](#).

Figure 14: Tighten screws

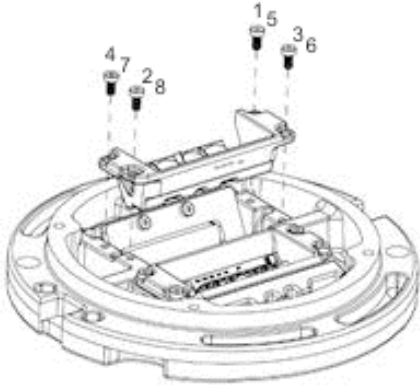

3. Connect the LED-cable(s) to the LED-board(s), note the cable orientation in the picture, see [Figure 15](#).

Figure 15: LED board

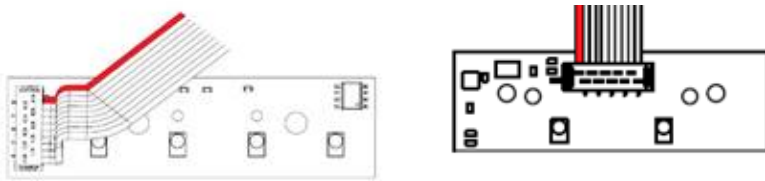

4. Assemble the light fixture.

6.2.4 Replace a Prism and its Gasket in an 8-inch Fixture

Remove

1. Disassemble the light fixture.
2. Detach and remove the LED board holder, including 4 screws from the body, using a 3 mm Allen key. See [Figure 16](#).
3. Remove the Teflon and steel protective plates from the LED board holder.
4. Remove the prism and its gasket, see [Figure 17](#).

Figure 16: Remove LED board holder

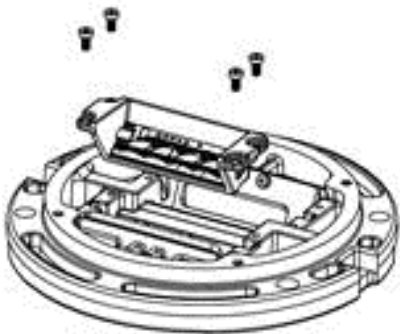
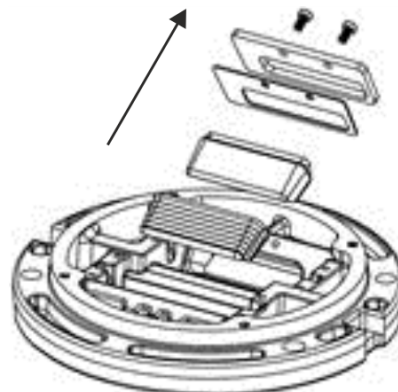

Figure 17: Remove prism and gasket



Replace

1. Lubricate the new prism gasket with CC Patron grease.
2. Place the prism gasket in the prism opening in the top cover.
3. Put the new prism into the new prism gasket, then push it all the way into the opening and hold for about a minute. See [Figure 18](#).

Figure 18: New prism into prism gasket

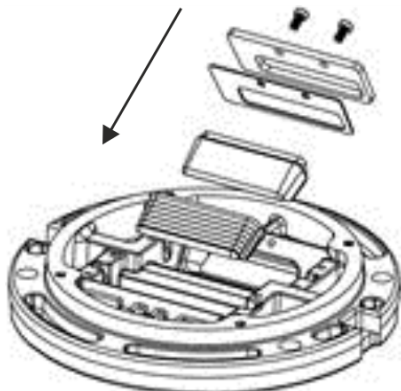

4. Check that the O-ring of the prism gasket is even in the chambered area.
5. Place the new Teflon protective plate and steel plate over the prism and prism gasket and tighten the two M4 screws to a torque of 4.5 Nm.
6. Looking from above, make sure the prism edge is parallel with the prism holder, see [Figure 19](#).

Figure 19: Prism holder edge

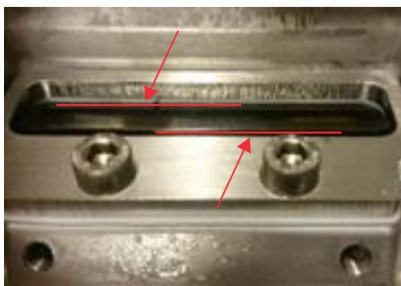

7. Use alcohol based cleaner to remove any grease or dust from the prism.

- Attach the LED board holder, including screws. The screws on the LED holder shall be tightened to a torque of 4.5 Nm, in sequence 1-4. Tighten the same screws again to a torque of 4.5 Nm, in sequence 5-8. See [Figure 20](#).
-



Note

The torquing sequence must be respected as it ensures correct positioning of the prism.

Figure 20: Tighten screws in sequence

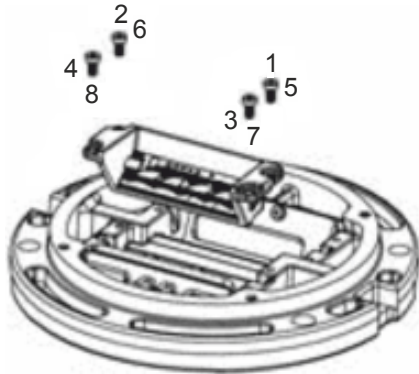

- Re-tighten the two screws on the steel plate to 4.5 Nm. See [Figure 20](#).
- Assemble the light fixture.
- Cut off any protruding prism gasket on the outside of the top cover.

6.2.5 Replace the Bottom Cover and Converter

Remove

- Disassemble the light fixture.
- From inside the housing, disconnect all cables from the LED board.

Replace

1. Place the new gasket on the new bottom cover with converter, see [Figure 21](#).

Figure 21: Gasket

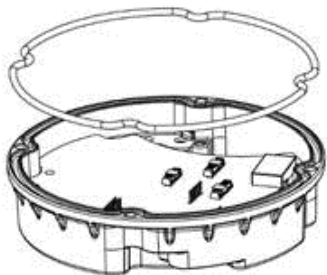

2. Connect the LED board cable(s). Note the orientation and alignment of the cables in [Figure 22](#) and [Figure 23](#).



Note

Make sure that light fixtures with only one LED board cable is connected to the LED B-channel.

Figure 22: Converter with 1 connector

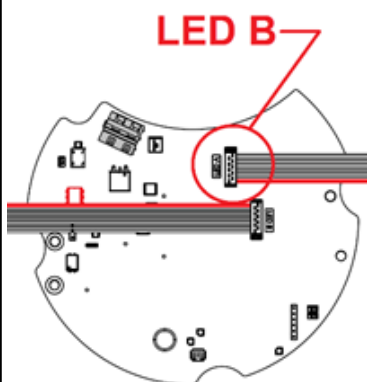
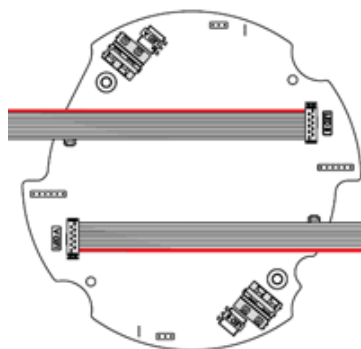

Figure 23: Converter with 2 connectors



3. Assemble the light fixture.

6.2.6 Reset the Fail-Open Converter 2.3

Open

1. Disconnect and disassemble the light fixture.
2. Make sure you have a 2-way electrical shunt/jumper (2.54 mm/0.100-inch spacing), see [Figure 24](#).

Figure 24: 2-way electrical shunt/jumper



Reset

1. Locate the 3-pin reset connector(s) on the converter. For the two-connector converter, there is one reset connector for each side.
 2. Place the 2-way electrical shunt (2.54 mm spacing) over the **two pins** marked red, see [Figure 25](#) and [Figure 26](#).
-

Figure 25: Converter with 1 connector

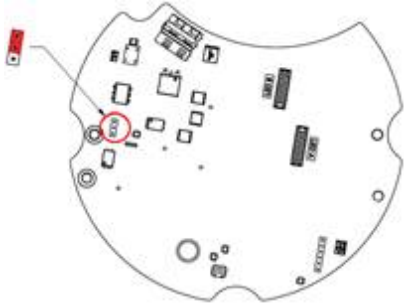
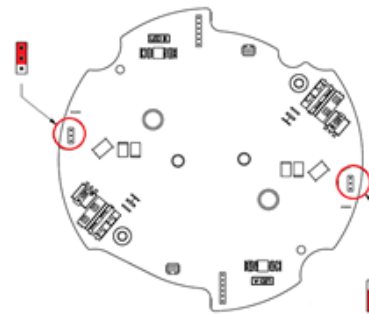

Figure 26: Converter with 2 connectors



3. Close the light fixture and connect it to a CCR.
 4. Energize the light fixture until there is a steady light, then turn the CCR off and unplug the light fixture.
 5. Disassemble the light fixture, then remove the two-way electrical shunt (2.54 mm spacing) from the pins.
 6. Assemble the light fixture and perform a functional test.
-

6.2.7 Reset the Fail-Open Converter 48010921 and 48011111

Parts

- Fuse resistor spare part kit: 20210209 (20pcs)

Info

- Converter with 1 connector have 2 fuse resistors
- Converter with 2 connectors have 4 fuse resistors

Reset / replace the fuse resistors

1. Disconnect and disassemble the light fixture.
2. Locate the fuse resistors, see [Figure 27](#) and [Figure 28](#).

Figure 27: Converter with 1 connector

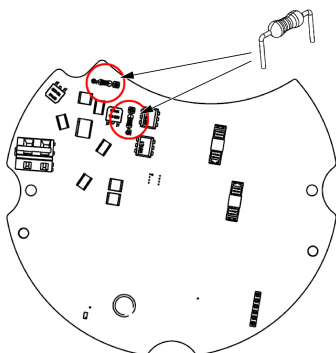
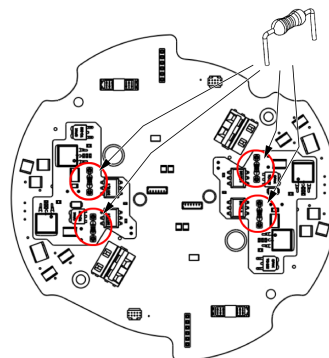

Figure 28: Converter with 2 connectors



3. Remove the fuse resistors by pulling away from the converter.
 - a. For converters with 1 connector, always replace both fuse resistors at the same time.
 - b. For converters with 2 connectors, always replace both fuse resistors related to the 1/2 channel that needs to be reset. If both 1 and 2 channel needs a reset, replace all 4 fuse resistors.
4. Dispose the old fuse resistor.
5. Place the legs of the new fuse resistors in the sockets.
6. Assemble the light fixture and perform a functional test.

7.0 Ordering Codes

Spare parts are available for RELIANCE 2 and RELIANCE IQ inset light fixtures. For more information, see www.adbsafegate.com and the spare part lists, or contact ADB SAFEGATE for assistance.

7.1 Ordering Code (RC-RZ-RX)

Ordering Code

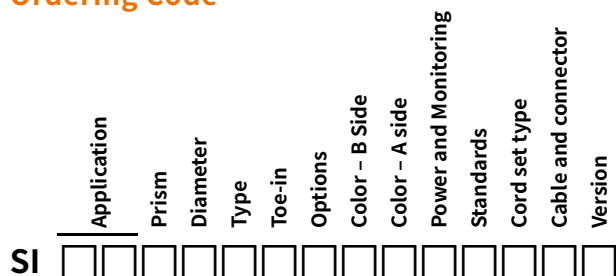

Application

RC = Runway Centerline L-850A(L)

RZ = Touchdown zone L-850B (L)

RX = RETIL

Prism

S = Standard prism

R = Reinforced prism

Diameter

1 = 8 in

2 = 12 in

Type

U = Unidirectional

B = Bidirectional

Toe-in

S = Straight

L = Left (for RZ only)

R = Right (for RZ only)

Options

0 = No options

Color - B Side

W = White

R = Red

Y = Yellow

Color - A side

W = White

R = Red

N = None

Power and Monitoring

S = 2.8 - 6.6 A, without monitoring (Non-MON)

M = 2.8 - 6.6 A, with monitoring (with fail-open)

P = 2.8 - 6.6 A/ 2 A, IQ0 (IQ disabled)

Q = 2.8 - 6.6 A/ 2 A, IQ1 (IQ enabled)

Standards

I = ICAO only (RX)

G = Global (RC, RZ)

Cord set type

A = FAA Style 6 (2 - pin-) plug

Cable and connector

2 = 1x 2-pin plug

3 = 2x 2-pin plugs

Version

3 = RELIANCE



Note

- Toe-in options only affect the touchdown zone L - 850B(L) fixtures
- The IQ functionality allows control and monitoring of the RELIANCE IQ. IQ1 fixtures are pre - configured for the specific position at delivery. This function is disabled in IQ0 fixtures but could be enabled later. IQ light fixtures are only available as a one connector option.

7.2 Spare Parts (RC-RZ-RX)



Note

Contact ADB SAFEGATE for assistance with ordering spare parts, www.adbsafegate.com.

Description		Quantity per		Order code
		fitting	order	
1a	Top plate, bi-directional	1	1	SGE.SP17107
1b	Top plate, uni-directional straight	1	1	SGE.SP17108
1c	Top plate, uni-directional left toe-in	1	1	SGE.SP17109
1d	Top plate, uni-directional right toe-in	1	1	SGE.SP17110
2a	Prism incl. gasket, protection plate and prism holder	2/1	2	SGE.SP17114
2b	Reinforced prism incl gasket, protection plate and prism holder	2/1	2	SGE.SP17115
3a	White LED assembly incl. reflector	2/1	1	SGE.SP17111
3b	Red LED assembly incl. reflector	1	1	SGE.SP17112
3c	Yellow LED assembly incl. reflector	1	1	SGE.SP17113
4	LED cable 180 mm	2/1	10	SGE.SP18650
5	Bottom cover gasket	1	10	SGE.SP17116
6a	Bottom cover assembly incl. RELIANCE IQ converter and secondary cable	1	1	SGE.SP17117
6b	Bottom cover assembly incl. 1 connector RELIANCE converter FAIL-OPEN and secondary cable	1	1	SGE.SP18059
6c	Bottom cover assembly incl. 2 connector RELIANCE converter FAIL-OPEN and secondary cable	1	1	SGE.SP19316
6d		1	1	SP.013101
6e		1	1	SP.013102
7	Fuse resistor (only for lights with monitoring option), pack of 20	1-2	20	6132.00.250

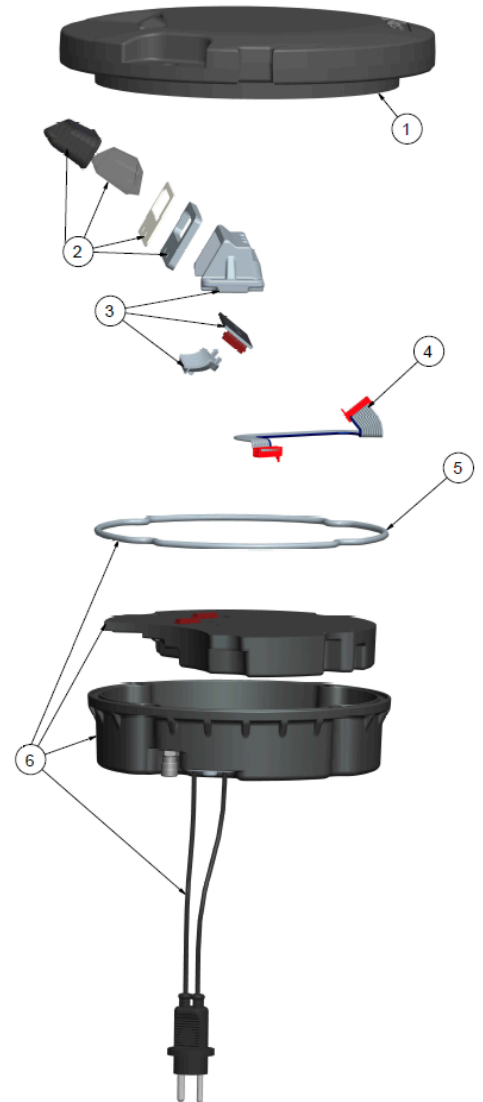

Note

All screws for fastening are included.

Component availability or design may be subject to change due to unforeseen circumstances. This document is subject to change or new information from ADB SAFEGATE, as and when available or if required, with reservation for error or price changes.

For more information or assistance with ordering spare parts, contact ADB SAFEGATE, see www.adbsafegate.com.

7.3 Ordering Code (TC)

Ordering Code

	Prism	Diameter	Type	Light Distribution	Options	Color - B Side	Color - A side	Power and Monitoring	Standards	Cord set type	Cable and connector	Version
SITC	<input type="checkbox"/>	<input type="checkbox"/>	<input type="checkbox"/>	<input type="checkbox"/>	<input type="checkbox"/>	<input type="checkbox"/>	<input type="checkbox"/>	<input type="checkbox"/>	<input type="checkbox"/>	<input type="checkbox"/>	<input type="checkbox"/>	<input type="checkbox"/>

Prism

S = Standard prism
R = Reinforced prism

Diameter

1 = 8 in
2 = 12 in

Type

U = Unidirectional
B = Bidirectional

Light Distribution

N = Narrow
W = Wide (ICAO)
C = Curved (bidirectional)
R = Right (unidirectional)
L = Left (unidirectional)
D = L-852D

Options

0 = No options

Color - B Side

G = G-Green (ICAO and MOS)
F = F-Green (ICAO and FAA)
Y = Yellow
R = Red
B = Blue

Color - A side

G = G-Green (MOS and ICAO)
F = F-Green (standard green for ICAO and FAA)
Y = Yellow
R = Red
B = Blue
N = Blank

Power and Monitoring

S = 2.8 - 6.6 A, without monitoring (Non-MON)
M = 2.8 - 6.6 A, with monitoring (with fail-open)
P = 2.8 - 6.6 A/ 2 A, IQ0 (IQ disabled)
Q = 2.8 - 6.6 A/ 2 A, IQ1 (IQ enabled)

Standards

I = ICAO
G = Global

Cord set type

A = Style 6 2-pin plug
F = Flat 3-pin plug (French, only for ICAO)

Cable and connector

2 = 1x 2-pin plug
3 = 2x 2-pin plug
4 = 1x 3-pin plug
5 = 2x 3-pin plug

Version

3 = RELIANCE



Note

- Fixture is compatible with both shallow 8" and 12" and deep 12" bases, check base compatibility matrix.
- The IQ - functionality allows control and monitoring of the RELIANCE IQ. IQ1 fittings are pre - configured for the specific position at delivery. This function is disabled in IQ0 fixtures but could be enabled later.
- IQ light fixtures are only available with connector option 2.
- Red is only available in 8 inch.
- Blue is only available in 8 inch.
- For global standard, the following color codes are used -
 - Narrow color combinations : FF, FY, YF, YY, FN and YN
 - Curved (C,R,L,D) color combinations : FF, YY, FN, and YN
- A 3-pin cable and connector are only available for the ICAO standard regardless of the color combination.

7.4 Spare Parts (TC)



Note

Contact ADB SAFEGATE for assistance with ordering spare parts, www.adbsafegate.com.

Description		Quantity per		Order code
		fitting	order	
1a	Top plate bidirectional straight	1	1	SGE.SP17107
1b	Top plate unidirectional straight	1	1	SGE.SP17108
2a	Prism incl. prism gasket, protection plate and prism holder	1	2	SGE.SP17114
2b	Reinforced prism incl. prism gasket, protection plate and prism holder	1	2	SGE.SP17115
3	LED assembly incl. reflector, LED holder and cable			
3a	Curved Left Blue	1	1	SGE.SP19156
3b	Curved Left F-Green L-852K(L)	1	1	SGE.SP19153
3c	Curved Left G-Green	1	1	SGE.SP19152
3d	Curved Left Red	1	1	SGE.SP19155
3e	Curved Left Yellow L-852K(L)	1	1	SGE.SP19154
3f	Curved Right Blue	1	1	SGE.SP19161
3g	Curved Right F-Green L-852K(L)	1	1	SGE.SP19158
3h	Curved Right G-Green	1	1	SGE.SP19157
3i	Curved Right Red	1	1	SGE.SP19160
3j	Curved Right Yellow L-852K(L)	1	1	SGE.SP19159
3k	Narrow F-Green L-852C(L)	1	1	SGE.SP18929
3l	Narrow G-Green	1	1	SGE.SP18928
3m	Narrow Yellow L-852C(L)	1	1	SGE.SP18927
3n	Wide Blue	1	1	SGE.SP19151
3o	Wide F-Green	1	1	SGE.SP19148
3p	Wide G-Green	1	1	SGE.SP19147
3q	Wide Red	1	1	SGE.SP19150
3r	Wide Yellow	1	1	SGE.SP19149
3s	L-852D(L) Yellow	1	1	SGE.SP18952
3t	L-852D(L) F-Green	1	1	SGE.SP18953
3u	L-852D(L) Red	1	1	SGE.SP19162
4	LED Cable 180 mm	1	10	SGE.SP18650
5	Bottom cover gasket	1	10	SGE.SP17116
6a	Bottom cover assembly incl. RELIANCE IQ converter and secondary cable	1	1	SGE.SP17117

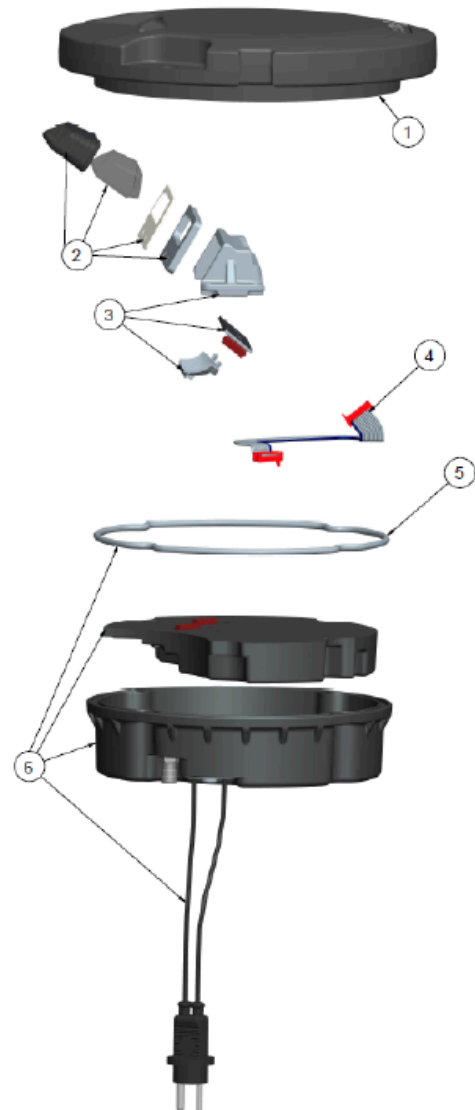

Description		Quantity per		Order code	
		fitting	order		
6b	Bottom cover assembly incl. 1 connector RELIANCE converter FAIL-OPEN and secondary cable	1	1	SGE.SP18059	
6c	Bottom cover assembly incl. 2 connector RELIANCE converter FAIL-OPEN and secondary cable	1	1	SGE.SP19316	
6d	Bottom cover assembly incl. 1 connector RELIANCE converter NON-MON and secondary cable	1	1	SP.013101	
6e	Bottom cover assembly incl. 2 connector RELIANCE converter NON-MON and secondary cable	1	1	SP.013102	
7	Fuse resistor (only for lights with monitoring option), pack of 20	1-2	20	6132.00.250	



Note

All screws for fastening are included.



Note

Component availability or design may be subject to change due to unforeseen circumstances. This document is subject to change or new information from ADB SAFEGATE, as and when available or if required, with reservation for error or price changes.

For more information contact ADB SAFEGATE, see www.adbsafegate.com.

7.5 Ordering Code (SB ICAO)

Ordering Code ICAO

	Prism	Diameter	Type	Light Distribution	Options	Color - B Side	Color - A side	Power and Monitoring	Standards	Cord set type	Cable and connector	Version
SISB	<input type="checkbox"/>	<input type="checkbox"/>	<input type="checkbox"/>	<input type="checkbox"/>	<input type="checkbox"/>	<input type="checkbox"/>	<input type="checkbox"/>	<input type="checkbox"/>	<input type="checkbox"/>	<input type="checkbox"/>	<input type="checkbox"/>	<input type="checkbox"/>

Prism

S = Standard prism
R = Reinforced prism

Diameter

1 = 8 in
2 = 12 in

Type

U = Unidirectional
B = Bidirectional

Light Distribution

W = Wide
R = Right (unidirectional)
L = Left (unidirectional)

Options

0 = No options

Color - B Side

R = Red

Color - A side

R = Red

N = Blank

Power and Monitoring

S = 2.8 - 6.6 A, without monitoring (Non-MON)

M = 2.8 - 6.6 A, with monitoring (with fail-open)

P = 2.8 - 6.6 A/ 2 A, IQ0 (IQ disabled)

Q = 2.8 - 6.6 A/ 2 A, IQ1 (IQ enabled)

Standards

I = ICAO

Cord set type

A = FAA Style 6 (2-pin) plug

F = Flat 3-pin plug

Cable and connector

2 = 1x 2-pin plug

3 = 2x 2-pin plug

4 = 1x 3-pin plug

5 = 2x 3-pin plug

Version

3 = RELIANCE



Note

- Fixture compatible with both shallow 8 - inch and 12 - inch and deep 12 - inch bases, check base compatibility matrix.
- The IQ - functionality allows control and monitoring of the RELIANCE IQ. IQ1 fittings are pre - configured for the specific position at delivery. This function is disabled in IQ0 fixtures but could be enabled later.
- IQ light fixtures are only available with connector option 2.
- A 3-pin cable and connector are only available for the ICAO standard regardless of the color combination.

7.6 Spare Parts (ICAO SB)



Note

Contact ADB SAFEGATE for assistance with ordering spare parts, www.adbsafegate.com.

Description		Quantity per		Order code
		fitting	order	
1a	Top plate bidirectional straight	1	1	SGE.SP17107
1b	Top plate unidirectional straight	1	1	SGE.SP17108
2a	Prism incl. prism gasket, protection plate and prism holder	1	2	SGE.SP17114
2b	Reinforced prism incl. prism gasket, protection plate and prism holder	1	2	SGE.SP17115
3	LED assembly incl. reflector, LED holder and cable			
3a	Curved Left Red	1	1	SGE.SP19155
3b	Curved Right Red	1	1	SGE.SP19160
3c	Wide Red	1	1	SGE.SP19150
4	LED Cable 180 mm	1	10	SGE.SP18650
5	Bottom cover gasket	1	10	SGE.SP17116
6a	Bottom cover assembly incl. RELIANCE IQ converter and secondary cable	1	1	SGE.SP17117
6b	Bottom cover assembly incl. 1 connector RELIANCE converter FAIL-OPEN and secondary cable	1	1	SGE.SP18059
6c	Bottom cover assembly incl. 2 connector RELIANCE converter FAIL-OPEN and secondary cable	1	1	SGE.SP19316
6d	Bottom cover assembly incl. 1 connector RELIANCE converter NON-MON and secondary cable	1	1	SP.013101
6e	Bottom cover assembly incl. 2 connector RELIANCE converter NON-MON and secondary cable	1	1	SP.013102
7	Fuse resistor (only for lights with monitoring option), pack of 20	1-2	20	6132.00.250

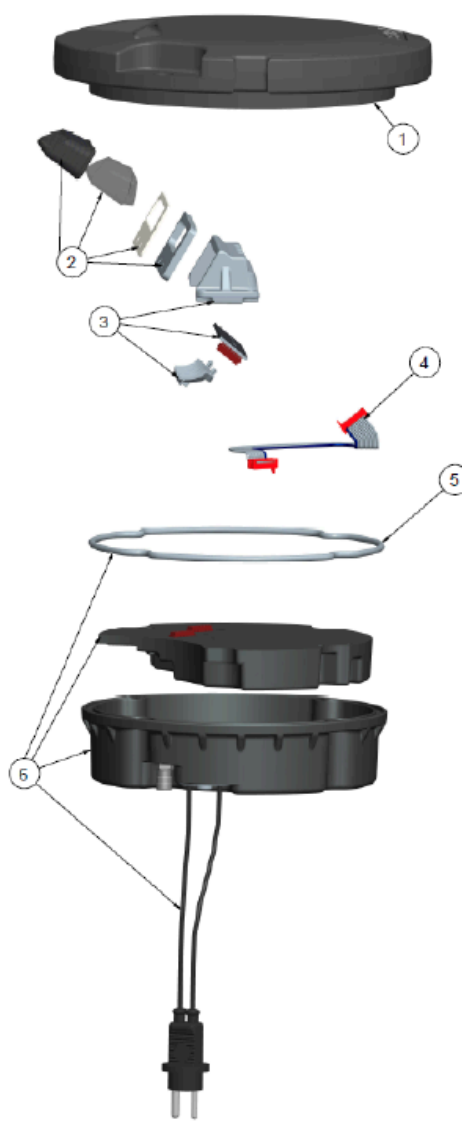

Note

All screws for fastening are included.



Note

Component availability or design may be subject to change due to unforeseen circumstances. This document is subject to change or new information from ADB SAFEGATE, as and when available or if required, with reservation for error or price changes.

For more information contact ADB SAFEGATE, see www.adbsafegate.com.

7.7 Ordering Code (SB FAA)

Ordering Code FAA

	Prism	Diameter	Type	Light Distribution	Options	Color – B Side	Color – A side	Power and Monitoring	Standards	Cord set type	Cable and connector	Version
SISB	<input type="checkbox"/>	<input type="checkbox"/>	<input type="checkbox"/>	<input type="checkbox"/>	<input type="checkbox"/>	<input type="checkbox"/>	<input type="checkbox"/>	<input type="checkbox"/>	<input type="checkbox"/>	<input type="checkbox"/>	<input type="checkbox"/>	<input type="checkbox"/>

Prism

S = Standard prism

R = Reinforced prism

Diameter

1 = 8 in

2 = 12 in

Type

U = Unidirectional

Light Distribution

S = Straight

Options

0 = No options

Color – B Side

R = Red

Color – A side

N = Blank

Power and Monitoring

S = 2.8 - 6.6 A, without monitoring (Non-MON)

M = 2.8 - 6.6 A, with monitoring (with fail-open)

P = 2.8 - 6.6 A/ 2 A, IQ0 (IQ disabled)

Q = 2.8 - 6.6 A/ 2 A, IQ1 (IQ enabled)

Standards

F = FAA AC 150/5345-46E

Cord set type

A = Style 6 (2-pin) plug

Cable and connector

2 = 1x 2-pin plug

Version

3 = RELIANCE



Note

- Fixture compatible with both shallow 8 - inch and 12 - inch and deep 12 - inch bases, check base compatibility matrix.
- The IQ - functionality allows control and monitoring of the RELIANCE IQ. IQ1 fittings are pre - configured for the specific position at delivery. This function is disabled in IQ0 fixtures but could be enabled later.
- IQ light fixtures are only available with connector option 2.
- A 3-pin cable and connector are only available for the ICAO standard regardless of the color combination.

7.8 Spare Parts (FAA SB)



Note

Contact ADB SAFEGATE for assistance with ordering spare parts, www.adbsafegate.com.

Description		Quantity per		Order code
		fitting	order	
1	Top plate Unidirectional	1	1	SGE.SP17108
2a	Prism incl. gasket, protection plate and prism holder	1	2	SGE.SP17114
2b	Reinforced prism incl. gasket, protection plate and prism holder	1	2	SGE.SP17115
3	LED assembly incl. reflector, LED holder and cable, Red	1	1	SGE.SP18600
4	LED cable 180 mm	1	10	SGE.SP18650
5	Bottom cover gasket	1	10	SGE.SP17116
6a	Bottom cover assembly incl. RELIANCE IQ converter and secondary cable	1	1	SGE.SP17117
6b	Bottom cover assembly incl. 1 connector RELIANCE converter FAIL-OPEN and secondary cable	1	1	SGE.SP18059
6c	Bottom cover assembly incl. 1 connector RELIANCE converter NON-MON and secondary cable	1	1	SP.013101
7	Fuse resistor (only for lights with monitoring option), pack of 20	1-2	20	6132.00.250

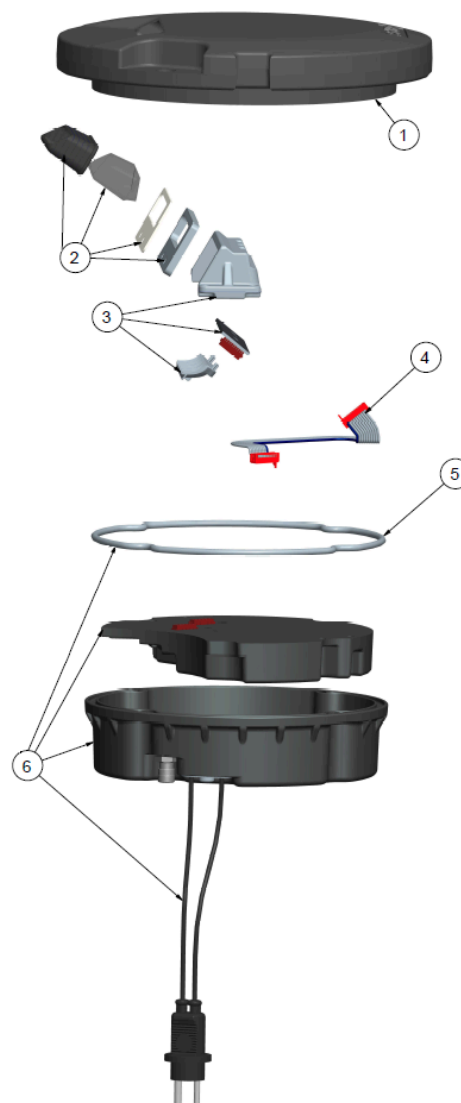

Note

All screws for fastening are included.

Component availability or design may be subject to change due to unforeseen circumstances. This document is subject to change or new information from ADB SAFEGATE, as and when available or if required, with reservation for error or price changes.

For more information or assistance with ordering spare parts, contact ADB SAFEGATE, see www.adbsafegate.com.

Appendix A: INTEROPERABILITY

Top cover versions



Note

For 8-inch fixtures only.

Figure 29: Top cover versions

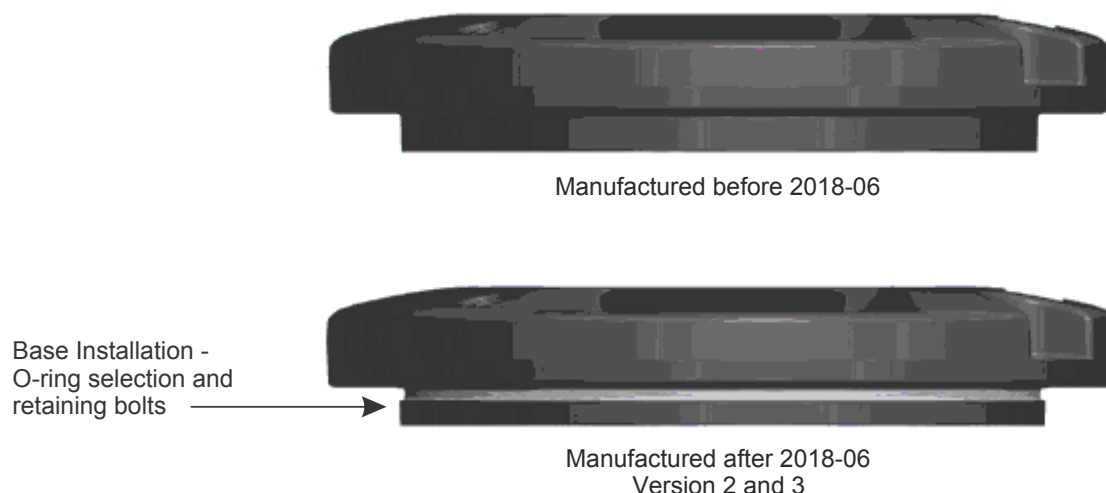

Base installation – O-ring selection and retaining bolts



Note

If the use of Loctite is not necessary or obligatory, then it is recommended to use a suitable lubricant when fastening the bolts. Use nickel or graphite grease, but do NOT use copper-based grease as it stimulates corrosion.



CAUTION

Use of incorrect combination of gaskets, bolts and nuts can create severe damages to the product installation and create multiple safety risks.

To obtain a safe and watertight installation the O - ring and retaining bolt stated in the document must be used.

You need to know what base the light fixture will be installed in, in order to choose the correct gasket, bolts and nuts.

Failure to follow these cautions can result in equipment damage or aircraft FOD.

Table 4: Manufactured before 2018-06 version 1

Base type	Required O-ring	Bolt installation		Stud installation	
		Required dimension	Recommended torque	Required nut	Recommended torque
Base 8 in-13X-..	Black O-ring	1411.20.522, metric screw kit 8 in M10×25 mm	40 Nm + locking washer, max height 2 mm	1411.20.430, self- locking nut kit 8 in M10 H100	35 Nm
Thorn 8 in (100 mm)	SGE.SP13092/10 pc				
Thorn 8 in (133 mm)	SGE.SPFR500355/ 25 pc SGE.SP11566/50 pc				

Table 5: Manufactured after 2018-06 version 2 and 3

Base type	Required O-ring	Bolt installation		Stud installation	
		Required dimension	Recommended torque	Required nut	Recommended torque
RELIANCE Base 8 in (135 mm)	Red O-ring SGE.SP24523/10 pc SGE.SP24526/100 pc	1411.20.522, metric screw kit 8 in M10×25 mm	40 Nm + locking washer, max height 2 mm	1411.20.430, self-locking nut kit 8 in M10 H100	35 Nm
ERNI 8 in EE08					
ERNI 8 in ED08 (133 mm)					
Thorn 8 in (100 mm)					
Thorn 8 in (133 mm)					
Thorn 8 in MK2 (133 mm)	Red O-ring SGE.SP24523/10 pc SGE.SP24526/100 pc	1411.20.522, metric screw kit 8 in M10x25 mm	40 Nm + locking washer, max height 2 mm	1411.20.430, self-locking nut kit 8 in M10 H100	35 Nm
IDM 6494 (120 mm)					
Adapter ring SG/Thorn/ID 8 in–12 in	Blue O-ring SGE.SP24521/10 pc SGE.SP24524/100 pc	1411.20.522, metric screw kit 8 in M10x25 mm	21 Nm + Loctite 2701 or 638	1411.20.430, self-locking nut kit 8 in M10 H100	21 Nm ¹²
ADB 8 in Eurobase					
Adapter ring ADB 8 in–12 in	Grey O-ring SGE.SP24522/10 pc SGE.SP24525/100 pc	1411.20.522, metric screw kit 8 in M10x25 mm	21 Nm + Loctite 2701 or 638	1411.20.430, self-locking nut kit 8 in M10 H100	21 Nm
ADB 8 in HPI					

The pictures below show photos of the bases mentioned above and the frame shows the color of the intended gasket.

Figure 30: Shallow bases



1. Do not use Loctite or washer with self-locking nut..
2. Do not use Loctite or washer with self-locking nut

Base installation – O-ring selection and retaining bolts 12-inch

For 12-inch light fixtures the O-ring is required. Refer to data sheet for ordering code for corresponding 12-inch base.



Note

If the use of Loctite is not necessary or obligatory, then it is recommended to use a suitable lubricant when fastening the bolts. Use nickel or graphite grease, but do NOT use copper-based grease as it stimulates corrosion.



CAUTION

Use of incorrect combination of gaskets, bolts and nuts can create severe damages to the product installation and create multiple safety risks.

To obtain a safe and watertight installation the O-ring and retaining bolt stated in the document must be used.

You need to know what base the light fixture will be installed in, in order to choose the correct gasket, bolts and nuts.

Failure to follow these cautions can result in equipment damage or aircraft FOD.

Table 6: Interoperability matrix

Base type	Required O-ring	Bolt installation		Stud installation	
		Required dimension	Recommended torque	Required nut	Recommended torque
RELIANCE 12-in (150 mm)	O-ring D259, 3×5,7 SP.013114/10pc SP.013115/100pc	1411.20.482	40 Nm +	1411.20.500	35 Nm
ERNI 12-in ED12-190		metric screw kit 12-in M10×25 mm	locking washer, max. height 2 mm	self-locking nut kit 12-in M10 H=100	
Thorn 12-in (150 mm)	O-ring D259, 3×5,7 SP.013114/10pc SP.013115/100pc	1411.20.482	40 Nm +	1411.20.500	35 Nm
Thorn 12-in (100 mm)		metric screw kit 12-in M10×25 mm	locking washer, max. height 2 mm ¹	self-locking nut kit 12-in M10 H=100	
ADB 12-in Eurobase	O-ring D259, 3×5,7 SP.013114/10pc SP.013115/100pc	1411.20.482 metric screw kit 12-in M10×25 mm	21 Nm + Loctite 2701 or 638	1411.20.500 self-locking nut kit 12-in M10 H=100	21 Nm
L-868 deep can with Flange	O-ring D259, 3×5,7 SP.013114/10pc SP.013115/100pc	1411.20.452 UNC screw kit	Reference EB83	N/A	N/A



Note

Version 1 with the code ending with 1, please ask your local sales representative for base compatibility.

1. Only with non-roll over lights

Appendix B: POWER TABLE

This load must be considered when calculating the total CCR load.



CAUTION

The RELIANCE fail-open is not to be connected to transformers larger than 100 W (-v2.3), 200 W (v3.0). A correct calibration of the CCR is important to achieve an accurate fail open response.

LED Runway Centerline, Touch Down Zone and RETIL, L-850A(L), L-850B(L)

Unidirectional Fixtures – 1 cord set, 25° C	Fixture load	Isolation transformer			CCR load
		Rating	Efficiency	Energy Use	
Runway Centerline, L-850A(L), Red	19 VA	25 W	0.7	11 VA	30 VA
Runway Touchdown Zone, L-850B(L), White	23 VA	25 W	0.7	11 VA	34 VA
Runway RETIL, Yellow	19 VA	25 W	0.7	11 VA	30 VA

Bidirectional Fixtures – 1 cord set, 25° C	Fixture load	Isolation transformer			CCR load
		Rating	Efficiency	Energy Use	
Runway Centerline, L-850A(L), White/White	31 VA	45 W	0.85	8 VA	39 VA
Runway Centerline, L-850A(L), White/Red	26 VA	45 W	0.85	8 VA	34 VA

Bidirectional Fixtures – 2 cord sets, 25° C	Fixture load		Isolation transformer						CCR load	
	B-side	A-Side	Rating		Efficiency		Energy Use		B-Side	A-Side
			B-Side	A-Side	B-side	A-Side	B-Side	A-Side		
Runway Centerline, L-850A(L), White/White	18 VA	18 VA	25 W	25 W	0.7	0.7	8 VA	11 VA	29 VA	29 VA
Runway Centerline, L-850A(L), White/Red	18 VA	13 VA	25 W	25 W	0.7	0.7	8 VA	11 VA	29 VA	24 VA

LED Taxiway Centerline, Lead-on/Exit, Apron Lead-in, L-852C(L), L-852D(L), L-852K(L)

Unidirectional Fixtures – 1 cord set, 25° C	Fixture load	Isolation transformer			CCR load
		Rating	Efficiency	Energy Use	
Taxiway Centerline Narrow, L-852C(L), F-Green	16 VA	25 W	0.7	11 VA	27 VA
Taxiway Centerline Narrow, L-852C(L), Yellow	16 VA	25 W	0.7	11 VA	27 VA
Taxiway Centerline Narrow, G-Green	18 VA	25 W	0.7	11 VA	29 VA
Taxiway Centerline Curved, L-852K(L), F-Green	17 VA	25 W	0.7	11 VA	28 VA
Taxiway Centerline Curved, L-852K(L), Yellow	17 VA	25 W	0.7	11 VA	28 VA
Taxiway Centerline Curved, G-Green	20 VA	25 W	0.7	11 VA	31 VA
Taxiway Centerline Curved, Blue	24 VA	25 W	0.7	11 VA	35 VA
Taxiway Centerline Wide, F-Green	17 VA	25 W	0.7	11 VA	28 VA
Taxiway Centerline Wide, Yellow	17 VA	25 W	0.7	11 VA	28 VA
Taxiway Centerline Wide, G-green	18 VA	25 W	0.7	11 VA	29 VA
Taxiway Centerline L-852D(L), F-Green	19 VA	25 W	0.7	11 VA	30 VA
Taxiway Centerline L-852D(L), Yellow	18 VA	25 W	0.7	11 VA	29 VA

Bidirectional Fixtures – 1 cord set, 25° C	Fixture load	Isolation transformer			CCR load
		Rating	Efficiency	Energy Use	
Taxiway Centerline Narrow, G-Green/G-Green	19 VA	25 W	0.7	11 VA	30 VA
Taxiway Centerline Narrow, L-852C(L), F-Green/F-Green	16 VA	25 W	0.7	11 VA	27 VA
Taxiway Centerline Narrow, L-852C(L), Yellow/Yellow	16 VA	25 W	0.7	11 VA	27 VA
Taxiway Centerline Narrow, L-852C(L), F-Green/Yellow	16 VA	25 W	0.7	11 VA	27 VA
Taxiway Centerline Narrow, G-Green/Yellow	18 VA	25 W	0.7	11 VA	29 VA
Taxiway Centerline Curved, G-Green/G-Green	24 VA	25 W	0.7	11 VA	35 VA
Taxiway Centerline Curved, L-852K(L), F-Green/F-Green	19 VA	25 W	0.7	11 VA	30 VA
Taxiway Centerline Curved, L-852K(L), Yellow/Yellow	19 VA	25 W	0.7	11 VA	30 VA
Taxiway Centerline Curved, Red/Red	22 VA	25 W	0.7	11 VA	33 VA
Taxiway Centerline Curved, Blue/Blue	30 VA	45 W	0.85	8 VA	38 VA
Taxiway Centerline Curved, F-Green/Yellow	19 VA	25 W	0.7	11 VA	30 VA
Taxiway Centerline Curved, G-Green/Yellow	22 VA	25 W	0.7	11 VA	33 VA
Taxiway Centerline Wide, G-Green/G-Green	24 VA	25 W	0.7	11 VA	35 VA
Taxiway Centerline Wide, F-Green/F-Green	19 VA	25 W	0.7	11 VA	30 VA
Taxiway Centerline Wide, Yellow/Yellow	19 VA	25 W	0.7	11 VA	30 VA
Taxiway Centerline Wide, Yellow/F-Green	22 VA	25 W	0.7	11 VA	33 VA
Taxiway Centerline Wide, Yellow/G-Green	30 VA	45 W	0.85	8 VA	38 VA
Taxiway Centerline Wide, Blue/Blue	23 VA	25 W	0.7	11 VA	34 VA
Taxiway Centerline L-852D(L), F-Green/F-Green	21 VA	25 W	0.7	11 VA	32 VA
Taxiway Centerline L-852D(L), Yellow/Yellow	22 VA	25 W	0.7	11 VA	33 VA
Taxiway Centerline L-852D(L), Yellow/F-Green	22 VA	25 W	0.7	11 VA	33 VA
Taxiway Centerline extra wide, Red/Yellow	22 VA	25 W	0.7	11 VA	33 VA
Taxiway Centerline L-852D(L), Red/Red	24 VA	25 W	0.7	11 VA	35 VA

Bidirectional Fixtures – 2 cord sets, 25° C	Fixture load		Isolation transformer						CCR load	
	B-side	A-Side	Rating		Efficiency		Energy Use		B-Side	A-Side
			B-Side	A-Side	B-side	A-Side	B-Side	A-Side		
Taxiway Centerline Narrow, G-Green/G- Green	12 VA	12 VA	25 W	25 W	0.7	0.7	11 VA	11 VA	23 VA	23 VA
Taxiway Centerline Narrow, L-852C(L), F- Green/F-Green	10 VA	10 VA	25 W	25 W	0.7	0.7	11 VA	11 VA	21 VA	21 VA
Taxiway Centerline Narrow, L-852C(L), Yellow/Yellow	10 VA	10 VA	25 W	25 W	0.7	0.7	11 VA	11 VA	21 VA	21 VA
Taxiway Centerline Narrow, L-852C(L), F- Green/Yellow	10 VA	10 VA	25 W	25 W	0.7	0.7	11 VA	11 VA	21 VA	21 VA
Taxiway Centerline Narrow, G-Green/Yellow	12 VA	10 VA	25 W	25 W	0.7	0.7	11 VA	11 VA	23 VA	21 VA
Taxiway Centerline Curved, G-Green/G- Green	14 VA	14 VA	25 W	25 W	0.7	0.7	11 VA	11 VA	25 VA	25 VA
Taxiway Centerline Curved, L-852K(L), F- Green/F-Green	11 VA	11 VA	25 W	25 W	0.7	0.7	11 VA	11 VA	22 VA	22 VA
Taxiway Centerline Curved, L-852K(L), Yellow/Yellow	11 VA	11 VA	25 W	25 W	0.7	0.7	11 VA	11 VA	22 VA	22 VA
Taxiway Centerline Curved, Red/Red	13 VA	13 VA	25 W	25 W	0.7	0.7	11 VA	11 VA	24 VA	24 VA
Taxiway Centerline Curved, Blue/Blue	18 VA	18 VA	25 W	25 W	0.7	0.7	11 VA	11 VA	29 VA	29 VA
Taxiway Centerline Curved, F-Green/Yellow	11 VA	11 VA	25 W	25 W	0.7	0.7	11 VA	11 VA	22 VA	22 VA
Taxiway Centerline Curved, G-Green/Yellow	14 VA	11 VA	25 W	25 W	0.7	0.7	11 VA	11 VA	25 VA	22 VA
Taxiway Centerline Wide, G-Green/G-Green	14 VA	14 VA	25 W	25 W	0.7	0.7	11 VA	11 VA	25 VA	25 VA
Taxiway Centerline Wide, F-Green/F-Green	11 VA	11 VA	25 W	25 W	0.7	0.7	11 VA	11 VA	25 VA	25 VA
Taxiway Centerline Wide, Yellow/Yellow	11 VA	11 VA	25 W	25 W	0.7	0.7	11 VA	11 VA	22 VA	22 VA
Taxiway Centerline Wide, Yellow/F-Green	11 VA	11 VA	25 W	25 W	0.7	0.7	11 VA	11 VA	22 VA	22 VA
Taxiway Centerline Wide, Yellow/G-Green	14 VA	11 VA	25 W	25 W	0.7	0.7	11 VA	11 VA	22 VA	22 VA
Taxiway Centerline Wide, Blue/Blue	18 VA	18 VA	25 W	25 W	0.7	0.7	11 VA	11 VA	29 VA	29 VA
Taxiway Centerline L-852D(L), F-Green/F- Green	13 VA	13 VA	25 W	25 W	0.7	0.7	11 VA	11 VA	24 VA	24 VA
Taxiway Centerline L-852D(L), Yellow/Yellow	12 VA	12 VA	25 W	25 W	0.7	0.7	11 VA	11 VA	23 VA	23 VA
Taxiway Centerline L-852D(L), Yellow/F- Green	13 VA	12 VA	25 W	25 W	0.7	0.7	11 VA	11 VA	24 VA	23 VA

Bidirectional Fixtures – 2 cord sets, 25° C	Fixture load		Isolation transformer						CCR load	
	B-side	A-Side	Rating		Efficiency		Energy Use		B-Side	A-Side
			B-Side	A-Side	B-side	A-Side	B-Side	A-Side		
Taxiway Centerline extra wide, Red/Yellow	14 VA	12 VA	25 W	25 W	0.7	0.7	11 VA	11 VA	25 VA	23 VA
Taxiway Centerline L-852D(L), Red/Red	14 VA	14 VA	25 W	25 W	0.7	0.7	11 VA	11 VA	25 VA	25 VA

LED Stopbar

Unidirectional Fixtures – 1 cord set, 25° C	Fixture load	Isolation transformer			CCR load	
		Rating		Efficiency		Energy Use
		B-Side	A-Side	B-side		A-Side
Stopbar, Red	19 VA	25 W	0.7	11 VA	30 VA	
Stopbar, L-852S(L), Red	23 VA	25 W	0.7	11 VA	34 VA	

Bidirectional Fixtures – 1 cord set, 25° C	Fixture load	Isolation transformer			CCR load	
		Rating		Efficiency		Energy Use
		B-Side	A-Side	B-side		A-Side
Stopbar, Red/Red	24 VA	25 W	0.7	11 VA	35 VA	

Bidirectional Fixtures – 2 cord sets, 25° C	Fixture load		Isolation transformer						CCR load	
	B-side	A-Side	Rating		Efficiency		Energy Use		B-Side	A-Side
			B-Side	A-Side	B-side	A-Side	B-Side	A-Side		
Stopbar, Red/Red	14 VA	14 VA	25 W	25 W	0.7	0.7	11 VA	11 VA	25 VA	25 VA



NOTICE

- No losses in the secondary cables are considered in the above table(s).
- No losses in the primary cables are considered in the above table(s).
- No spare CCR load has been considered in the above table(s).
- The Isolation transformer efficiency considered in the above table(s) is estimated. These efficiency values depend on the isolating transformer supplier.
- No loads due to extra equipment on the circuit (e.g. ILCMS equipment) are considered in the above table(s).
- For Reliance IQ version:
The minimum Isolation Transformer rating is 65W.
To allow for communication bandwidth, an overhead of 12VA should be considered when determining the Isolation Transformer rating.
- For Reliance Fail-open version:
The maximum Isolation Transformer rating is 200W.
- If part of a Reliance 2A system:
The data provided in the above table(s) is not applicable if part of a 2A reliance system. In this case, please contact your local ADB Safegate representative.

Appendix C: CABLE LOSS

The cable resistance R (ohms) for 1 conductor is calculated with following formula:

- $R \text{ (ohms)} = \text{resistivity of material (ohm m)} \times \text{length (m)} / \text{cross sectional area (m}^2\text{)}$
- For copper conductors the resistivity is $1.72 \times 10^{-8} \text{ (m}^2\text{)}$

Example; for 1 km 2.5 mm^2 copper conductor, the resistance R is calculated as follows:

$$1.72 \times 10^{-8} \times 1000 / 2.5 \times 10^{-6} \text{ m}^2 = 6.88 \text{ ohms}$$

The loss (Watt) is then $R \times I^2$ or $6.88 \text{ ohms} \times 6.6^2 \text{ A}^2 = 299.69 \text{ W/km}$ or 0.299 W/m .

The loss (Watt) for a secondary cable with 2 conductors is thus $2 \times 0.299 = 0.599$ or 0.6 W/m .

As such we can calculate:

- Secondary cable for a 2.5 mm^2 Cu-wire (2 conductors): 0.6 W/m
- Secondary cable for a 4 mm^2 Cu-wire (2 conductors): 0.4 W/m
- Primary cable for a 6 mm^2 Cu-wire (1 conductor): 0.12 W/m

The cable between the isolation transformer and the lamp adds losses that cannot be ignored when dimensioning the circuits and selecting rating for secondary transformers and regulators.



WARNING

Cable lengths should not exceed 100 meters.

For a secondary cable of e.g., 20 m of 2.5 mm^2 CU-wire, $20 \text{ m} \times 0.6 \text{ W/m} = 12 \text{ W}$ equals the additional loss to be taken into account.

For a primary cable of e.g., 100 m of 6 mm^2 CU-wire, $100 \text{ m} \times 0.12 \text{ W/m} = 12 \text{ W}$ equals the additional loss to be taken into account.

Appendix D: SUPPORT

Our experienced engineers are available for support and service at all times, 24 hour/7 days a week. They are part of a dynamic organization making sure the entire ADB SAFEGATE is committed to minimal disturbance for airport operations.

ADB SAFEGATE Support

Technical Support – Global

Customers in Europe, the Middle East, Africa or Asia Pacific are more than welcome to our portal for technical support. Trained in all areas of system issues, troubleshooting, quality control and technical assistance, our highly experienced Technical support specialists are available 24 hours a day, seven days a week to provide assistance over the phone. In the Americas, we also offer live technical support.

Live Technical Support – Americas

If at any time you have a question or concern about your product, contact ADB SAFEGATE's US-based technical support specialists, available 24 hours a day, seven days a week, to assist you via phone.

ADB SAFEGATE Americas Technical Service & Support (US & Canada) :+1-800-545-4157

ADB SAFEGATE Americas Technical Service & Support (Canada): +1-905-631-1597

ADB SAFEGATE Americas Technical Service & Support (International): +1-614-861-1304

We can also be reached via email during regular business hours:

Airfield and Gate: techservice.us@adbsafegate.com

Gate: gateservice.us@adbsafegate.com

We look forward to working with you!

Before You Call

When you have an airfield lighting or system control system problem, prior to calling, please ensure the following:

- Review the product's manual and troubleshooting guide.
- Be located with the product ready to troubleshoot.
- Have all necessary information available: airport code/company name, customer id number, contact phone number/email address, product/part number.
- Have a True RMS meter available and any other necessary tools.

When calling about an issue with Safedock A-VDGS, we can serve you better if you collect the following information before you call:

- Relevant information regarding the issue you are calling about, such as gate number, flight number, aircraft type and time of the event.
- What, if any, actions have been taken to resolve the issue prior to the call.
- If available, provide a CCTV recording of the incident to aid in aligning the information from the Safedock log file.

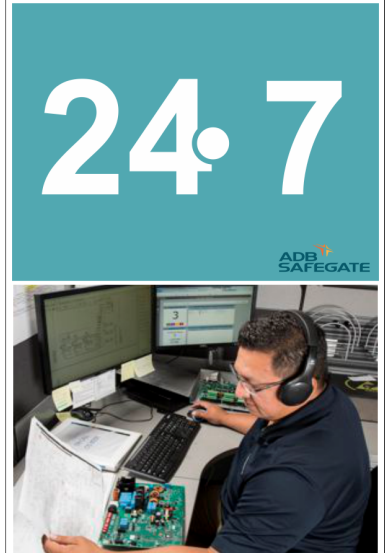

Note

For more information, see www.adbsafegate.com, contact ADB SAFEGATE Support via email at support@adbsafegate.com or Europe: +32 2 722 17 11

Americas: +1 614 861 1304. Press 3 for technical service or press 4 for sales support.

China: +86 (10) 8476 0106

Middle East and Africa: +971 4 452 7575

D.1 ADB SAFEGATE Website

The ADB SAFEGATE website, www.adbsafegate.com, offers information regarding our airport solutions, products, company, news, links, downloads, references, contacts and more.

D.2 Recycling

D.2.1 Local Authority Recycling

The disposal of ADB SAFEGATE products is to be made at an applicable collection point for the recycling of electrical and electronic equipment. The correct disposal of equipment prevents any potential negative consequences for the environment and human health, which could otherwise be caused by inappropriate waste handling. The recycling of materials helps to conserve natural resources. For more detailed information about recycling of products, contact your local authority city office.

D.2.2 ADB SAFEGATE Recycling

ADB SAFEGATE is fully committed to environmentally-conscious manufacturing with strict monitoring of our own processes as well as supplier components and sub-contractor operations. ADB SAFEGATE offers a recycling program for our products to all customers worldwide, whether or not the products were sold within the EU.

ADB SAFEGATE products and/or specific electrical and electronic component parts which are fully removed/separated from any customer equipment and returned will be accepted for our recycling program.

All items returned must be clearly labeled as follows:

- For ROHS/WEEE Recycling
- Sender contact information (Name, Business Address, Phone number).
- Main Unit Serial Number.

ADB SAFEGATE will continue to monitor and update according for any future requirements for EU directives as and when EU member states implement new regulations and or amendments. It is our aim to maintain our compliance plan and assist our customers.

