



## Model 6022

### Tipping Bucket Rain Gauge

PRODUCT MANUAL  
6022/Rev B

  
**ADB**  
**SAFEGATE**

## A.0 Disclaimer / Standard Warranty

### CE certification

The equipment listed as CE certified means that the product complies with the essential requirements concerning safety and hygiene. The European directives that have been taken into consideration in the design are available on written request to ADB SAFEGATE.

### ETL certification

The equipment listed as ETL certified means that the product complies with the essential requirements concerning safety and C22.2 No.180:13 (R2018) regulations. The CSA directives that have been taken into consideration in the design are available on written request to ADB SAFEGATE.

### All Products Guarantee

ADB SAFEGATE will correct by repair or replacement per the applicable guarantee below, at its option, equipment or parts which fail because of mechanical, electrical or physical defects, provided that the goods have been properly handled and stored prior to installation, properly installed and properly operated after installation, and provided further that Buyer gives ADB SAFEGATE written notice of such defects after delivery of the goods to Buyer. Refer to the Safety section for more information on Material Handling Precautions and Storage precautions that must be followed.

ADB SAFEGATE reserves the right to examine goods upon which a claim is made. Said goods must be presented in the same condition as when the defect therein was discovered. ADB SAFEGATE further reserves the right to require the return of such goods to establish any claim.

ADB SAFEGATE's obligation under this guarantee is limited to making repair or replacement within a reasonable time after receipt of such written notice and does not include any other costs such as the cost of removal of defective part, installation of repaired product, labor or consequential damages of any kind, the exclusive remedy being to require such new parts to be furnished.

ADB SAFEGATE's liability under no circumstances will exceed the contract price of goods claimed to be defective. Any returns under this guarantee are to be on a transportation charges prepaid basis. For products not manufactured by, but sold by ADB SAFEGATE, warranty is limited to that extended by the original manufacturer. This is ADB SAFEGATE's sole guarantee and warranty with respect to the goods; there are no express warranties or warranties of fitness for any particular purpose or any implied warranties of fitness for any particular purpose or any implied warranties other than those made expressly herein. All such warranties being expressly disclaimed.

### Standard Products Guarantee

Products manufactured by ADB SAFEGATE are guaranteed against mechanical, electrical, and physical defects (excluding lamps) which may occur during proper and normal use for a period of two years from the date of ex-works delivery, and are guaranteed to be merchantable and fit for the ordinary purposes for which such products are made.

---

#### NOTE



See your applicable sales agreement for a complete warranty description.

Replaced or repaired equipment under warranty falls into the warranty of the original delivery. No new warranty period is started for these replaced or repaired products.

---

### FAA Certified products manufactured by ADB SAFEGATE

ADB SAFEGATE L858 Airfield Guidance Signs are warranted against mechanical and physical defects in design or manufacture for a period of 2 years from date of installation, per FAA AC 150/5345-44 (applicable edition).

ADB SAFEGATE LED products (with the exception of obstruction lighting) are warranted against electrical defects in design or manufacture of the LED or LED specific circuitry for a period of 4 years from date of installation, per FAA EB67 (applicable edition). These FAA certified constant current (series) powered LED products must be installed, interfaced and powered with and through products certified under the FAA Airfield Lighting Equipment Program (ALECP) to be included in this 4 (four) year warranty. This includes, but is not limited to, interface with products such as Base Cans, Isolation Transformers, Connectors, Wiring, and Constant Current Regulators.

**Revision History**

Revision	Date	Summary of Changes
A	2019 Aug 15	Initial release.
B	2025 Apr 1	ADB SAFEGATE (ECP#ADBSG-0001)

# Contents

<b>1. Overview .....</b>	<b>5</b>
1.1 Features.....	5
1.2 Models.....	5
<b>2. Installation .....</b>	<b>6</b>
2.1 Physical Installation .....	6
2.1.1 Pad Mounting .....	6
2.1.2 Mast Mounting.....	8
2.1.3 Tower Mounting.....	9
2.2 Connections .....	12
2.2.1 Signal Cable .....	12
2.2.2 Heater Cable.....	12
<b>3. Maintenance .....</b>	<b>13</b>
3.1 AWOS Maintenance Procedures .....	13
3.1.1 Monthly Maintenance.....	13
3.1.2 Triannual Maintenance .....	13
3.1.3 Annual Maintenance .....	13
<b>4. Calibration .....</b>	<b>14</b>
<b>5. Specifications .....</b>	<b>15</b>
<b>6. Warranty .....</b>	<b>16</b>

# 1. Overview

The Model 6022 series of Tipping Bucket Rain Gauges is a freestanding receptacle for measuring precipitation. It contains an open top, which allows precipitation to fall into the upper portion, called the collector. The collector funnel is made of gold-anodized aluminum. Collected water is funneled to a tipping bucket, which fills up and causes a momentary closure of a magnetic switch once the tipping bucket fills to the point where it tips over. This empties the bucket in preparation for additional measurements. The discharged water passes out of the rain gauge with no need for emptying.

The rain gauge may be connected to an event counter on a data logger or to a display such as offered by an AWOS to show and log accumulated precipitation.

Heated models allow the water equivalent of all types of precipitation, including snow and freezing rain, to be measured and logged. Two low-power heating elements are controlled thermostatically with an additional thermal overload. The heaters allow the rain gauge to be used year-round while at the same time minimizing the amount of evaporation.

The aluminum housing is finished with a white powder-coat to withstand years of exposure to the environment.

## 1.1 Features

- Interfaces to virtually all data acquisition systems
- Knife-edge collector optimizes rainfall catch
- Splash-out protection and screen reduce wind errors
- Easy installation and maintenance
- Integrated bubble level
- Lightweight aluminum exterior with anodized aluminum collector for weather resistance

## 1.2 Models

Model	Precipitation Measured per Tip	Heated	Supply Voltage
6012-A	0.01"	—	—
6022-A	0.01"	✓	120 VAC, 1.65 A

**Table 1. 6022 Models**



## MOUNTING TEMPLATE

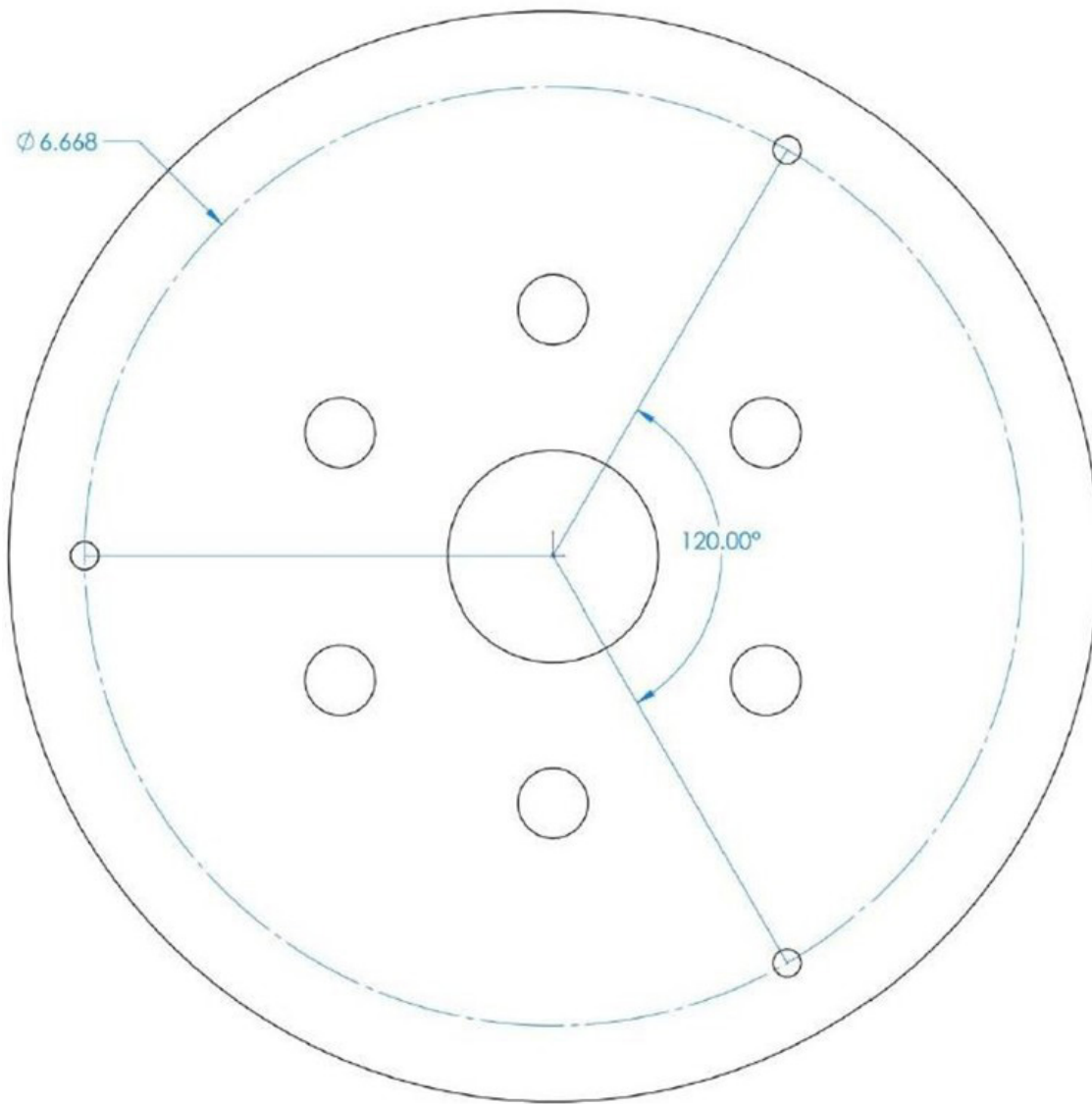
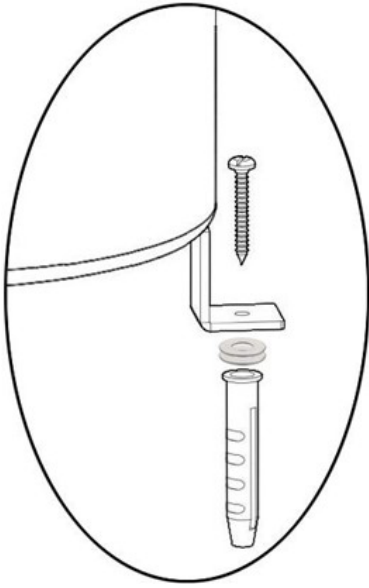

Figure 2. Mounting Template

## Model 6022 Tipping Bucket Rain Gauge

3. Install three 1/4" screw plug inserts into the holes just drilled. Position the rain gauge feet over the holes. Use washers under the feet to level the rain gauge, referring to the bubble level to make sure the rain gauge is level. Secure the rain gauge with corrosion-resistant #6 sheet metal screws.



**Figure 3. Level and Secure Rain Gauge to Concrete Pad**

### 2.1.2 Mast Mounting

1. Use hose clamps to secure the rain gauge to a mast as shown in Figure 4. Hose clamps are included with the rain gauge to allow it to be clamped to a mast with a diameter up to 1".

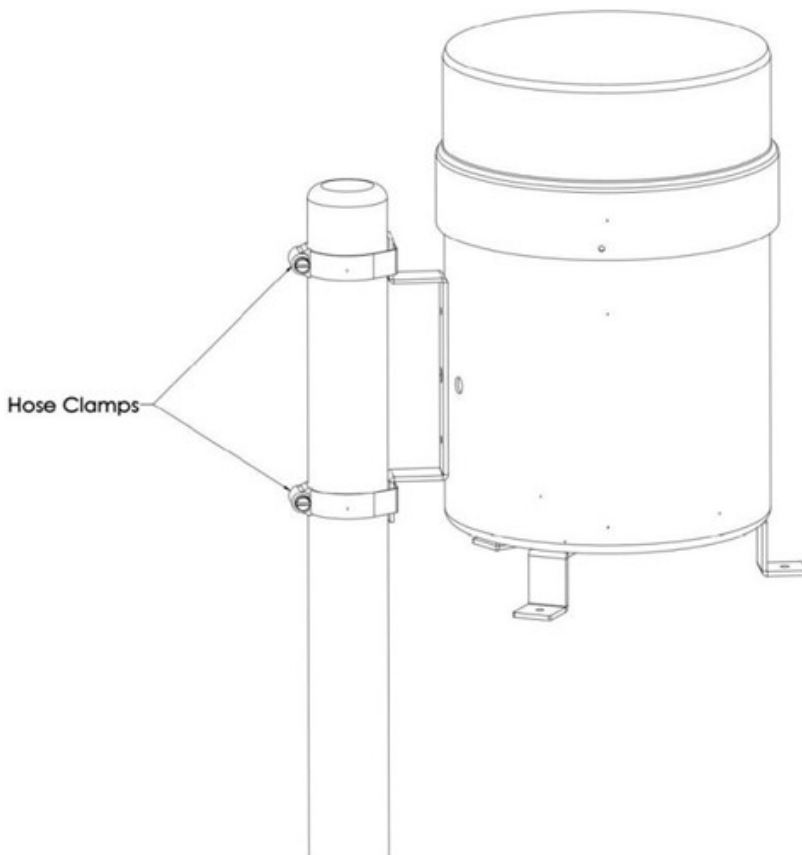

**Figure 4. Mast Mounting**

2. Make sure that the mast is properly guyed so that vibration in high winds is kept to a minimum.

### 2.1.3 Tower Mounting

The M488169-01 Tower Mounting kit is available to mount the rain gauge on a tower as shown in Figure 5.

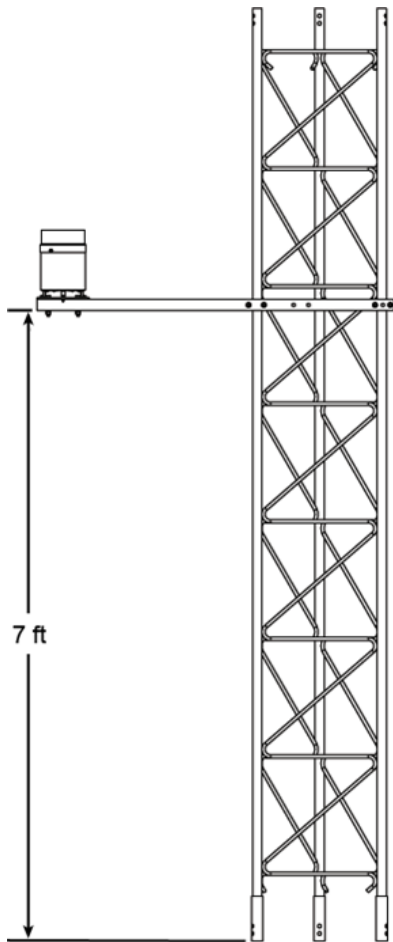
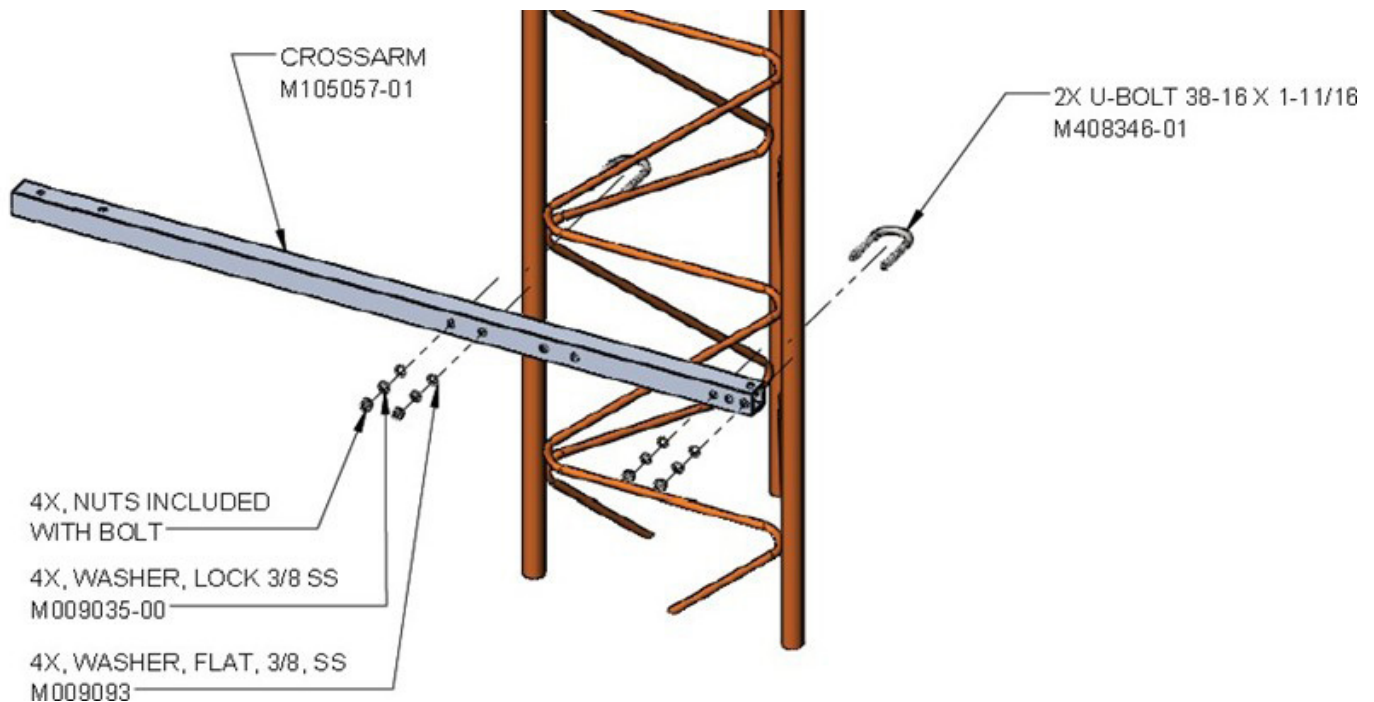

Figure 5. Tower Mounting

1. Use the U bolts and the associated nuts and washers to attach the crossarm to the tower. If a level is available use it to level the crossarm before tightening the nuts.



Model 6022 Tipping Bucket Rain Gauge

- Use the two 3/8-16 × 2.5 bolts and the 3/8-16 nuts and washers to secure the mounting plate to the crossarm.

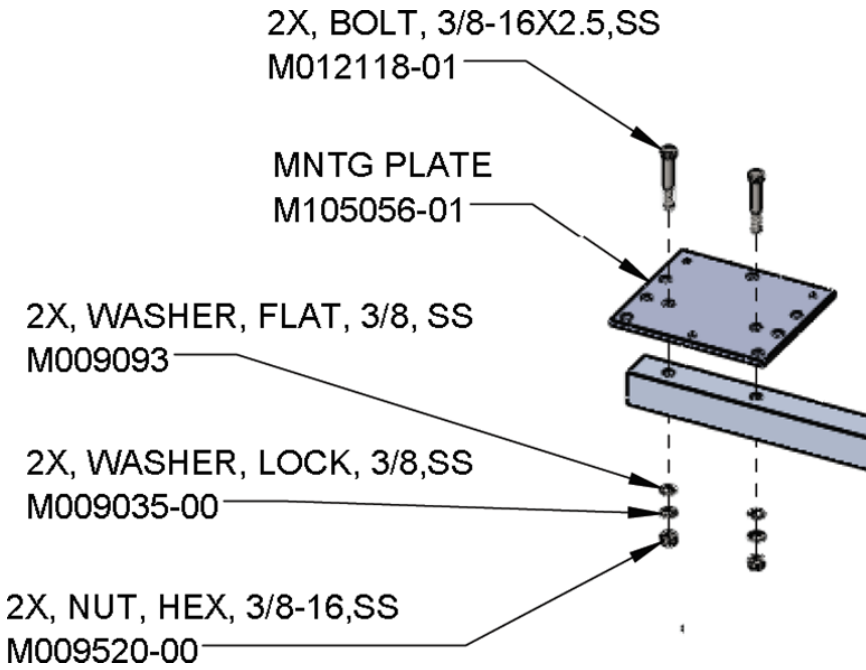

- Position the rain gauge feet over the mounting plate to line up the feet with the corresponding mounting holes.

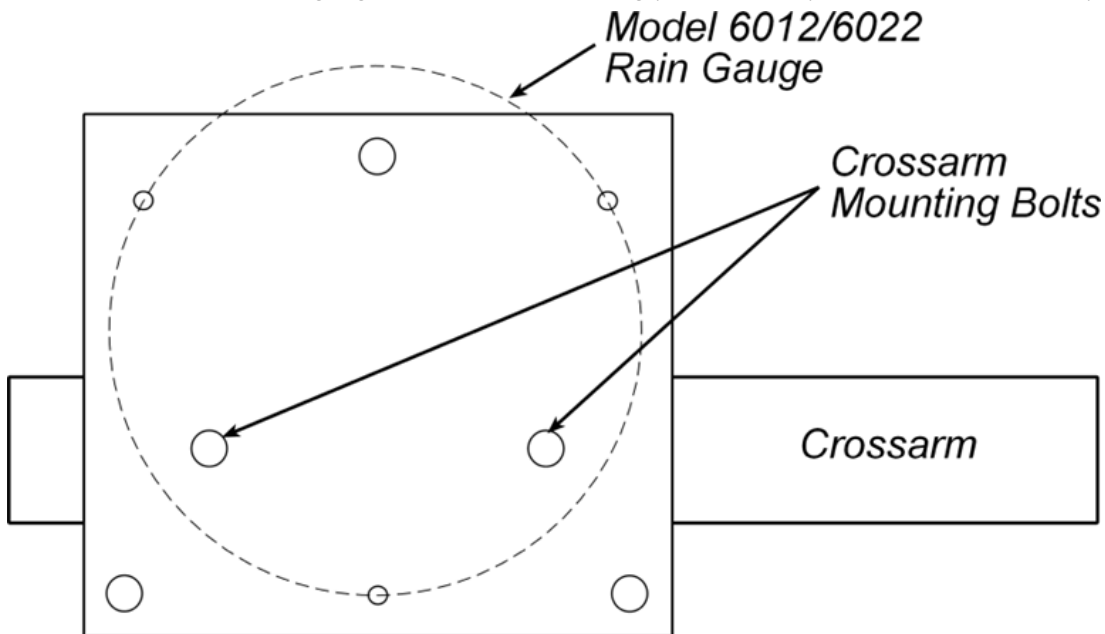

Model 6022 Tipping Bucket Rain Gauge

4. Insert flat #6 washers as needed between the rain gauge feet and the mounting plate to level the rain gauge, referring to the bubble level to make sure the rain gauge is level, Secure the rain gauge to the mounting plate with the 6-32 pan head screws and flange locknuts.

**3X, PAN HEAD SCREW WITH FLAT, SPLIT WASHER, SS 6-32**

**M006111-00**

RAIN GAUGE

MNTG PLATE

**M105056-01**

3X+, WASHER, FLAT #6

**M009116-00**

3X, FLANGE LOCKNUT, 6-32

**M009646-00**

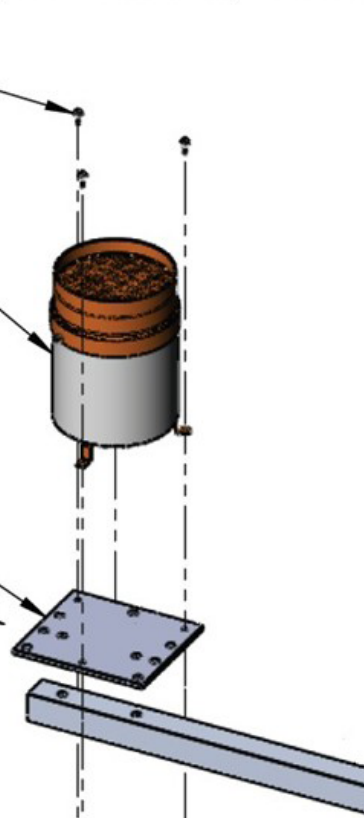

## 2.2 Connections

Once the rain gauge has been installed physically, remove the screen and the gold funnel to observe the black tipping bucket. The tipping bucket should not be held in a dead center position by the magnetic attraction of the bucket magnet and the magnetic switch. Press either end of the bucket down against the stop to be sure it is not centered.

### 2.2.1 Signal Cable

The signal cable from the rain gauge may be shortened or lengthened as required. Strip off ¼" insulation from the ends of the two wires from the signal cable. Connect the two wires to the display or logging device.

When connecting the signal cable to the Model 1190 or 1190-I Data Collection Platform, connect one of the two wires to terminal 8 of TB3 and connect the other wire to terminal 7.

When connecting the signal cable to the Model 1191-I Data Collection Platform, connect one of the two wires to Pin 1 of Terminal Block P4 and connect the other wire to Pin 2.

### 2.2.2 Heater Cable

The rain gauge heater consists of two heaters, one attached to the underside of the inner collector funnel and one attached to the lower inside portion of the sensor housing. The two heaters are connected in series with a thermostat positioned near the tipping assembly.

Local electrical codes vary, and so no power cord or conduit is supplied with the heated rain gauge. A service box attached to the outside of the rain gauge has conduit fitting knock-outs on all four sides. A cable gland is included if codes allow cabling to be run without conduit, also three wire nuts have been provided. Open the service box to access the three heater wires to connect to the power cord.



Figure 6. Heater Power Cord Service Box

## 3. Maintenance

Normal maintenance is limited to cleaning debris out of the orifice. Use the precipitation screen during periods of rain to prevent insects and stones from entering the rain gauge, but remove this screen during the winter. When the rain gauge is installed as part of an AWOS, special maintenance procedures are required, as described below.

### 3.1 AWOS Maintenance Procedures

AWOS maintenance procedures are divided into three categories: monthly, triannual, and annual. The maintenance routines are performed according to that schedule.

#### 3.1.1 Monthly Maintenance

1. Remove the screen from the funnel of the rain gauge and gently tap the screen to free any dirt or debris.
2. Check the rain gauge funnel for insect activity (cobwebs, hornet's nests, etc.), as well as birds' nests, and clean out any debris. Be sure to check underneath the instrument as well.
3. Water and a damp cloth can be used to clean the rain gauge as needed. Do not use soap.
4. Never paint the rain gauge.
5. Reinstall the screen
6. If the ambient temperature is below 40°F, feel the rain gauge cover to check operation of the heaters. If they are working, the outer cover should be warm to the touch.
7. If repairs are needed, report the problem.

#### 3.1.2 Triannual Maintenance

Perform the monthly maintenance. No additional procedures are required.

#### 3.1.3 Annual Maintenance

1. Remove the collection funnel thumbscrews and lift up the collection funnel .
2. Check the level by viewing the bubble level provided on the base. Adjust if necessary.
3. Inspect the interior of the rain gauge for physical lightning damage.
4. Remove any dirt or debris that may be present inside the rain gauge.
5. If the ambient temperature is below 40°F, feel the rain gauge funnel and bottom to check the operation of the heaters. If they are working, the rain gauge funnel and bottom should be warm to the touch.
6. Note the precipitation quantity on the DCP's LCD display. Toggle the bucket assembly one cycle. Again read the precipitation quantity on the LCD display. It must be 1 count greater than before.
7. Replace the outer cover or collection funnel, and the thumbscrews. Coat the thumbscrews with anti-seize compound. Replace the screen.

## 4. Calibration

This chapter describes the calibration procedure for the tipping bucket rain gauge. Calibration is performed at the factory prior to shipping, and will only need to be done if damage has occurred or if serious doubt about its accuracy exists.

1. Make sure that the rain gauge is leveled by centering the bubble on the bubble level.
2. Calibration is best accomplished using a uniform flow of water at a rate of 400 mL per hour. Allow a few preliminary bucket tips to insure that the internal funnel, tipping bucket, and drains are wet before beginning the calibration procedure.
3. Use a recording device to count the switch contacts, and position a calibrated container with 946 mL of filtered water over the orifice (offset to one side so water is not dripping directly into the center of the orifice).
4. Apply the water flow, directing the water flow to the edge of the collection orifice.
5. The counts resulting from this calibrated amount of water passing through the rain gauge should be  $200 \pm 4$ .
6. If the count in Step 5 does not agree with the specified accuracy, then the bucket stops may need adjustment as described in Step 8. below. Before making any changes to the instrument, repeat Steps 4 and 5 several times to insure no errors were made during the test.
7. Turn the rain gauge upside down to locate the two adjustment screws. When adjusting the calibration of the rain gauge, both screws must be turned the same amount to keep the tipping bucket balanced.
8. Keep the rain gauge in the upside down position to adjust the set screws. To increase the reading, turn each set screw clockwise (increases height of screw). To decrease the reading, turn each set screw counter clockwise. As a general rule, a  $\frac{1}{4}$  turn of both screws represents approximately 1 count.
9. Repeat Steps 4 and 5 to check the adjustment that was just made.

*Use the bubble level to make sure the rain gauge is level when it is returned to the field.*

ADB Safegate offers the Model 60103 Precipitation Gauge for checking the rain gauge calibration in the field. A measured amount of water, equal to 200 tips of the bucket assembly, is directed into the rain gauge at a constant rate of 2 inches per hour.

## 5. Specifications

Parameter	Specification		
	6012-A		6022-A
Sensor Type	Tipping bucket		
Switch	Momentary potted reed switch		
Output	135 ms switch closure		
Sensitivity	1 tip per 0.01" precipitation		
Resolution	0.01"		
Calibrated Accuracy	±1% (0–2"/h)		
Precipitation Measurement Rate	0–700 mm/h (0–27"/h)		
Collector Orifice	6.060" (154 mm)		
Height	10.25" (260 mm)		
Heaters	Collector	N/A	71 W
	Housing	N/A	127 W
Thermostat Set Point	N/A		7°C (45°F)
Heater Power	N/A		120 VAC, 1.65 A
<b>Environmental</b>			
Operating Temperature	0 to +70°C (32 to +158°F)		-54 to +70°C (-65 to +158°F)
Storage Temperature	-40 to +85°C (-40 to +185°F)		
Relative Humidity	0–100%, noncondensing		
<b>Mechanical</b>			
Dimensions (without feet or pole mounting arm)	Rain Gauge	260 mm H × 163 mm D (10.25" H × 6.4"D)	
	Heater Service Box (on side of rain gauge)	63 mm W × 63 mm H × 55 mm D (2.5" W × 2.5"H × 2.2"D)	
Weight	1.8 kg (4.0 lb)		

## **6. Warranty**

Any defect in design, materials, or workmanship which may occur during proper and normal use during a period of 1 year from date of installation or a maximum of 2 years from shipment will be corrected by repair or replacement by ADB Safegate.

# Optimizing Airside Operations From approach to take-off

SMARTER. BETTER. **NOW.**

  
**ADB  
SAFEGATE**  
[www.adbsafegate.com](http://www.adbsafegate.com)