



AXON Taxiway Inset Lights, 8-inch and 12-inch

FAA L-852A/B/C/D/J/K(L) Centerline; L-852S(L) Stop Bar; Triple Line Centerline; ICAO Centerline; Runway Entrance Light (REL, RWSL); Enhanced Taxiway Centerline; ICAO Stop Bar

User Manual

UM-5056, Rev. 1.0.27, 2025/09/03

ADB SAFEGATE

A.0 Disclaimer / Standard Warranty

CE certification

The equipment listed as CE certified means that the product complies with the essential requirements concerning safety and hygiene. The European directives that have been taken into consideration in the design are available on written request to ADB SAFEGATE.

ETL certification

The equipment listed as ETL certified means that the product complies with the essential requirements concerning safety and C22.2 No.180:13 (R2018) regulations. The CSA directives that have been taken into consideration in the design are available on written request to ADB SAFEGATE.

All Products Guarantee

ADB SAFEGATE will correct by repair or replacement per the applicable guarantee below, at its option, equipment or parts which fail because of mechanical, electrical or physical defects, provided that the goods have been properly handled and stored prior to installation, properly installed and properly operated after installation, and provided further that Buyer gives ADB SAFEGATE written notice of such defects after delivery of the goods to Buyer. Refer to the Safety section for more information on Material Handling Precautions and Storage precautions that must be followed.

ADB SAFEGATE reserves the right to examine goods upon which a claim is made. Said goods must be presented in the same condition as when the defect therein was discovered. ADB SAFEGATE further reserves the right to require the return of such goods to establish any claim.

ADB SAFEGATE's obligation under this guarantee is limited to making repair or replacement within a reasonable time after receipt of such written notice and does not include any other costs such as the cost of removal of defective part, installation of repaired product, labor or consequential damages of any kind, the exclusive remedy being to require such new parts to be furnished.

ADB SAFEGATE's liability under no circumstances will exceed the contract price of goods claimed to be defective. Any returns under this guarantee are to be on a transportation charges prepaid basis. For products not manufactured by, but sold by ADB SAFEGATE, warranty is limited to that extended by the original manufacturer. This is ADB SAFEGATE's sole guarantee and warranty with respect to the goods; there are no express warranties or warranties of fitness for any particular purpose or any implied warranties of fitness for any particular purpose or any implied warranties other than those made expressly herein. All such warranties being expressly disclaimed.

Standard Products Guarantee

Products manufactured by ADB SAFEGATE are guaranteed against mechanical, electrical, and physical defects (excluding lamps) which may occur during proper and normal use for a period of two years from the date of ex-works delivery, and are guaranteed to be merchantable and fit for the ordinary purposes for which such products are made.



Note

See your applicable sales agreement for a complete warranty description.

Replaced or repaired equipment under warranty falls into the warranty of the original delivery. No new warranty period is started for these replaced or repaired products.

FAA Certified products manufactured by ADB SAFEGATE

ADB SAFEGATE L858 Airfield Guidance Signs are warranted against mechanical and physical defects in design or manufacture for a period of 2 years from date of installation, per FAA AC 150/5345-44 (applicable edition).

ADB SAFEGATE LED products (with the exception of obstruction lighting) are warranted against electrical defects in design or manufacture of the LED or LED specific circuitry for a period of 4 years from date of installation, per FAA EB67 (applicable edition). These FAA certified constant current (series) powered LED products must be installed, interfaced and powered with and through products certified under the FAA Airfield Lighting Equipment Program (ALECP) to be included in this 4 (four) year warranty. This includes, but is not limited to, interface with products such as Base Cans, Isolation Transformers, Connectors, Wiring, and Constant Current Regulators.



Note

See your sales order contract for a complete warranty description.

Replaced or repaired equipment under warranty falls into the warranty of the original delivery. No new warranty period is started for these replaced or repaired products.

Liability



WARNING

Use of the equipment in ways other than described in the catalog leaflet and the manual may result in personal injury, death, or property and equipment damage. Use this equipment only as described in the manual.

ADB SAFEGATE cannot be held responsible for injuries or damages resulting from non-standard, unintended uses of its equipment. The equipment is designed and intended only for the purpose described in the manual. Uses not described in the manual are considered unintended uses and may result in serious personal injury, death or property damage.

Unintended uses, includes the following actions:

- Making changes to equipment that have not been recommended or described in this manual or using parts that are not genuine ADB SAFEGATE replacement parts or accessories.
- Failing to make sure that auxiliary equipment complies with approval agency requirements, local codes, and all applicable safety standards if not in contradiction with the general rules.
- Using materials or auxiliary equipment that are inappropriate or incompatible with your ADB SAFEGATE equipment.
- Allowing unskilled personnel to perform any task on or with the equipment.

Copyright Statement

This manual or parts thereof may not be reproduced, stored in a retrieval system, or transmitted, in any form or by any means, electronic, mechanical, photocopying, recording, nor otherwise, without the author's prior written consent.

This manual could contain technical inaccuracies or typographical errors. The author reserves the right to revise this manual from time to time in the contents thereof without obligation of the author to notify any person of such revision or change. Details and values given in this manual are average values and have been compiled with care. They are not binding, however, and the author disclaims any liability for damages or detriments suffered as a result of reliance on the information given herein or the use of products, processes or equipment to which this manual refers. No warranty is made that the use of the information or of the products, processes or equipment to which this manual refers will not infringe any third party's patents or rights. The information given does not release the buyer from making their own experiments and tests.

Table of Contents

1.0 Safety	1
1.1 Safety Messages.....	1
1.1.1 Introduction to Safety.....	2
1.1.2 Intended Use.....	2
1.1.3 Material Handling Precautions : Storage.....	3
1.1.4 Operation Safety.....	3
1.1.5 Maintenance Safety.....	3
1.1.6 Material Handling Precautions: Fasteners.....	4
1.1.7 Material Handling Precautions, ESD.....	4
2.0 About this Manual	5
2.1 How to work with the Manual.....	5
2.2 Abbreviations and Terms.....	5
3.0 Introduction	7
3.1 Product Information.....	8
3.2 Dimensions and Weight.....	11
4.0 Installation	13
4.1 Safety Considerations.....	13
4.2 Photobiological safety.....	13
4.3 Inspect on delivery.....	14
4.4 Unpack the Unit.....	14
4.5 Verify Input Requirements and Equipment Needed.....	14
4.6 Installation Overview.....	15
4.6.1 Tools Required.....	15
4.6.2 Installation.....	16
4.6.3 Typical L-868 Assembly.....	17
4.6.4 Configuration.....	18
4.6.5 Installation and Removal of the Inset Light Fixture.....	18
4.6.6 Test the Light Fixture for Leaks (Water-tightness).....	19
4.7 Toe-In.....	21
4.7.1 Definition of Light Emission Directions.....	21
5.0 Maintenance	23
5.1 Basic Maintenance Program.....	23
5.2 Recommended Maintenance Program for Optimal Service Life.....	24
5.2.1 Recommendation.....	25
5.3 Prism Cleaning Procedure for Inset Light Fixtures.....	26
5.4 Workshop Maintenance.....	28
5.4.1 Open the Light Fixture — Disconnect the Bottom Pan from the Top Cover.....	28
5.4.2 Replace the Bottom Pan Assembly.....	28
5.4.3 Replace the Power Wire Harness.....	29
5.4.4 Replace the Light Engine Assembly.....	29
5.4.5 Replace the Prism and its Gasket.....	30
5.4.6 Replace the Style-6 Cord Set.....	32
5.4.7 Replace the Secondary Cable — SJO Cord Set.....	33
5.4.8 Resetting the Fail-open Converter.....	33
5.4.9 Replace the Top Cover Assembly.....	34
5.4.10 Close the Light Fixture — Connect the Bottom Pan to the Top Cover.....	35
6.0 Ordering Codes	37
6.1 L852-A/B/C/D/J/K-(L), LED Taxiway Centerline, Lead-on/Exit, Apron Lead-in (FAA).....	37
6.2 LED Taxiway Centerline (ICAO).....	38
6.3 LED Triple Line Taxiway Centerline Light.....	39
6.4 LED L-852S(L) LED Stop Bar (FAA).....	40
6.5 LED Stopbar (ICAO).....	40
6.6 LED Runway Status L-850T(L), Runway Intersection (THL/RIL) and Runway Entry Light (REL).....	41
7.0 Spare Parts	43
7.1 Versions and Exploded View.....	43
7.2 Illustrations.....	45

7.3 Taxiway Centerline Light FAA.....	48
7.4 Taxiway Centerline Light ICAO.....	51
7.5 Triple Line Taxiway Centerline Light.....	54
7.6 Stop Bar Light FAA.....	56
7.7 Stop Bar Light ICAO.....	58
7.8 RWSL Runway Entry Light (REL).....	61
8.0 POWER TABLES	63
A.0 Cable Loss.....	67
B.0 Interoperability	69
C.0 Winter Operations: Snow Plowing Guidelines for inset Lights	73
D.0 SUPPORT.....	79
D.1 ADB SAFEGATE Website.....	79
D.2 Recycling.....	80
D.2.1 Local Authority Recycling.....	80
D.2.2 ADB SAFEGATE Recycling.....	80

List of Figures

Figure 1: 8-Inch and 12-inch Taxiway Insets	7
Figure 2: 8-inch Taxiway Lights	11
Figure 3: 12-inch Taxiway Lights	12
Figure 4: Installation on shallow base	16
Figure 5: Anti-vibration washer example	18
Figure 6: 12-inch shallow base, class 1, direct-mounted fixture	18
Figure 7: Pressure Release Screw	20
Figure 8: Pressure Test Fitting Tool	20
Figure 9: Pressure Test Fitting Tool	20
Figure 10: Toe-in	21
Figure 11: Light emission directions	22
Figure 12: Preventive Maintenance	25
Figure 13: Visual Inspection Interval	25
Figure 14: High-Pressure Water Jet Precautions	27
Figure 15: Power harness replacement	29
Figure 16: LED bracket removal	29
Figure 17: Removal of Deformed Orange Thermal Pad	30
Figure 18: Mounting Light Engine(s)	30
Figure 19: Light engine removal	31
Figure 20: Sequence Diagram	31
Figure 21: Secondary Cable Replacement	32
Figure 22: Secondary SJO cable	33
Figure 23: 1-connector	34
Figure 24: 2-connector	34
Figure 25: Light engine removal	35
Figure 26: Sequence Diagram	35
Figure 27: Top Cover Placement	36
Figure 28: Taxiway Insets, Cord Set Options	43
Figure 29: 8-Inch(Left) and 12-Inch(Right) Taxiway Inset Light	44
Figure 30: Top Cover Assemblies, 8-inch 12-inch	45
Figure 31: Bottom Pan Assembly	46
Figure 32: Prism Spares	46
Figure 33: Ground lugs, package of 5	46
Figure 34: Cable Clamps, package of 5	46
Figure 35: Mounting screws, package of 100	47
Figure 36: Pressure release screws, package of 5	47
Figure 37: Shallow bases	71
Figure 38: Snowplow blade with well aligned segments	74
Figure 39: Snowplow blade with wear and steps between segments	75
Figure 40: Snowplow blade without clearance	75
Figure 41: Snowplow with support wheels	76
Figure 42: Snowplow without support wheels	76

List of Tables

Table 1: Maintenance tasks	23
Table 2: Expected service life (only critical areas defined)	26
Table 3: Interoperability matrix – 12-inch	69
Table 4: Interoperability matrix – 8-inch	70

1.0 Safety

Introduction to Safety

This section contains general safety instructions for installing and using ADB SAFEGATE equipment. Some safety instructions may not apply to the equipment in this manual. Task- and equipment-specific warnings are included in other sections of this manual where appropriate.

1.1 Safety Messages

HAZARD Icons used in this manual

For all HAZARD symbols in use, see the Safety section. All symbols must comply with ISO and ANSI standards.

Carefully read and observe all safety instructions in this manual, which alert you to safety hazards and conditions that may result in personal injury, death or property and equipment damage and are accompanied by the symbols shown below.

	<p>WARNING</p> <p>Failure to observe a warning may result in personal injury, death or equipment damage.</p>
	<p>DANGER – Risk of electrical shock or ARC FLASH</p> <p>Disconnect equipment from line voltage. Failure to observe this warning may result in personal injury, death, or equipment damage. ARC Flash may cause blindness, severe burns or death.</p>
	<p>WARNING – Wear personal protective equipment</p> <p>Failure to observe may result in serious injury.</p>
	<p>WARNING – Do not touch</p> <p>Failure to observe this warning may result in personal injury, death, or equipment damage.</p>
	<p>CAUTION</p> <p>Failure to observe a caution may result in equipment damage.</p>
	<p>ELECTROSTATIC SENSITIVE DEVICES</p> <p>This equipment may contain electrostatic devices.</p>

Qualified Personnel

	<p>Important Information</p> <p>The term qualified personnel is defined here as individuals who thoroughly understand the equipment and its safe operation, maintenance and repair. Qualified personnel are physically capable of performing the required tasks, familiar with all relevant safety rules and regulations and have been trained to safely install, operate, maintain and repair the equipment. It is the responsibility of the company operating this equipment to ensure that its personnel meet these requirements.</p> <p>Always use required personal protective equipment (PPE) and follow safe electrical work practice.</p>
--	---

1.1.1 Introduction to Safety



CAUTION

Unsafe Equipment Use

This equipment may contain electrostatic devices, hazardous voltages and sharp edges on components

- Read installation instructions in their entirety before starting installation.
- Become familiar with the general safety instructions in this section of the manual before installing, operating, maintaining or repairing this equipment.
- Read and carefully follow the instructions throughout this manual for performing specific tasks and working with specific equipment.
- Make this manual available to personnel installing, operating, maintaining or repairing this equipment.
- Follow all applicable safety procedures required by your company, industry standards and government or other regulatory agencies.
- Install all electrical connections to local code.
- Use only electrical wire of sufficient gauge and insulation to handle the rated current demand. All wiring must meet local codes.
- Route electrical wiring along a protected path. Make sure they will not be damaged by moving equipment.
- Protect components from damage, wear, and harsh environment conditions.
- Allow ample room for maintenance, panel accessibility, and cover removal.
- Protect equipment with safety devices as specified by applicable safety regulations
- If safety devices must be removed for installation, install them immediately after the work is completed and check them for proper functioning prior to returning power to the circuit.

Failure to follow these instructions can result in serious injury, death or equipment damage

Additional Reference Materials



Important Information

- IEC – International Standards and Conformity Assessment for all electrical, electronic and related technologies.
- IEC 60364 – Electrical Installations in Buildings.
- CSA – C22.2 No.180:13 (R2018), series isolating transformers for airport lighting.
- FAA Advisory: AC 150/5340-26 (current edition), Maintenance of Airport Visual Aid Facilities.
- Maintenance personnel must refer to the maintenance procedure described in the ICAO Airport Services Manual, Part 9.
- ANSI/NFPA 79, Electrical Standards for Metalworking Machine Tools.
- National and local electrical codes and standards.

1.1.2 Intended Use



CAUTION

Use this equipment as intended by the manufacturer

This equipment is designed to perform a specific function, do not use this equipment for other purposes

- Using this equipment in ways other than described in this manual may result in personal injury, death or property and equipment damage. Use this equipment only as described in this manual.

Failure to follow this instruction can result in serious injury or equipment damage

1.1.3 Material Handling Precautions : Storage



CAUTION

Improper Storage

Store this equipment properly

- If equipment is to be stored prior to installation, it must be protected from the weather and kept free of condensation and dust.

Failure to follow this instruction can result in equipment damage

1.1.4 Operation Safety



CAUTION

Improper Operation

Do Not Operate this equipment other than as specified by the manufacturer

- Only qualified personnel, physically capable of operating the equipment and with no impairments in their judgment or reaction times, should operate this equipment.
- Read all system component manuals before operating this equipment. A thorough understanding of system components and their operation will help you operate the system safely and efficiently.
- Before starting this equipment, check all safety interlocks, fire-detection systems, and protective devices such as panels and covers. Make sure all devices are fully functional. Do not operate the system if these devices are not working properly. Do not deactivate or bypass automatic safety interlocks or locked-out electrical disconnects or pneumatic valves.
- Protect equipment with safety devices as specified by applicable safety regulations.
- If safety devices must be removed for installation, install them immediately after the work is completed and check them for proper functioning.
- Route electrical wiring along a protected path. Make sure they will not be damaged by moving equipment.
- Never operate equipment with a known malfunction.
- Do not attempt to operate or service electrical equipment if standing water is present.
- Use this equipment only in the environments for which it is rated. Do not operate this equipment in humid, flammable, or explosive environments unless it has been rated for safe operation in these environments.
- Never touch exposed electrical connections on equipment while the power is ON.

Failure to follow these instructions can result in serious injury, death or equipment damage.

1.1.5 Maintenance Safety



DANGER

ELECTRIC SHOCK HAZARD

THIS EQUIPMENT MAY CONTAIN ELECTROSTATIC DEVICES

- DO NOT OPERATE A SYSTEM THAT CONTAINS MALFUNCTIONING COMPONENTS. IF A COMPONENT MALFUNCTIONS, TURN THE SYSTEM OFF IMMEDIATELY.
- DISCONNECT AND LOCK OUT ELECTRICAL POWER.
- ALLOW ONLY QUALIFIED PERSONNEL TO MAKE REPAIRS OR REPLACE MALFUNCTIONING COMPONENTS ACCORDING TO INSTRUCTIONS PROVIDED IN MANUAL.

FAILURE TO FOLLOW THESE INSTRUCTIONS CAN RESULT IN DEATH OR EQUIPMENT DAMAGE

1.1.6 Material Handling Precautions: Fasteners



DANGER

FOREIGN OBJECT DAMAGE - FOD

THIS EQUIPMENT MAY CONTAIN FASTENERS THAT CAN LOOSEN UNLESS TORQUED PROPERLY.

- ONLY USE FASTENERS OF THE SAME TYPE AS ORIGINALLY SUPPLIED WITH THE EQUIPMENT.
- USE OF INCORRECT COMBINATION OF GASKETS, BOLTS AND NUTS CAN CAUSE SEVERE DAMAGE TO THE PRODUCT AND CREATE MULTIPLE SAFETY RISKS .
- YOU NEED TO KNOW WHAT BASE THE LIGHT FIXTURE WILL BE INSTALLED IN, IN ORDER TO CHOOSE THE CORRECT GASKET, BOLTS AND NUTS.
- BOLT TYPE, LENGTH, AND TORQUE VALUE ARE DETERMINED BY TYPE OF BASE, HEIGHT OF SPACERS USED, AND CLAMP FORCE REQUIRED IN FAA ENGINEERING BRIEF NO 83 (LATEST REVISION).
- USE ONLY ANTI-VIBRATION WASHERS WITH THE FIXING BOLTS AS DEFINED IN FAA EB 83 (LATEST EDITION) TO AVOID THE RISK OF LOOSENING BOLTS . DO NOT USE OF ANY OTHER TYPE OF WASHER (SUCH AS SPLIT-LOCK WASHERS). FOR INSTALLATION OTHER THAN FAA, USE THE BASE CAN MANUFACTURER'S RECOMMENDATIONS.
- ALWAYS TIGHTEN THE FASTENERS TO THE RECOMMENDED TORQUE USING A CALIBRATED TORQUE WRENCH.
- APPLY THE RECOMMENDED TYPE OF ADHESIVE AND FOLLOW THE ADHESIVE INSTRUCTIONS CAREFULLY.

FAILURE TO FOLLOW THESE WARNINGS MAY CAUSE THE FASTENERS TO LOOSEN, POSSIBLY DAMAGING THE EQUIPMENT. THIS CAN LEAD TO THE HIGHLY DANGEROUS SITUATION OF FOD, WITH POTENTIALLY LETHAL CONSEQUENCES.



Note

To minimize the risk of errors, the ADB SAFEGATE Sales Representative will have information on which gasket goes with which base. This information is also provided in the product Data sheets, the User Manuals and the Spare Part Lists.

1.1.7 Material Handling Precautions, ESD



CAUTION

Electrostatic Sensitive Devices

This equipment may contain electrostatic devices

- Protect from electrostatic discharge.
- Electronic modules and components should be touched only when this is unavoidable e.g. soldering, replacement.
- Before touching any component of the cabinet you shall bring your body to the same potential as the cabinet by touching a conductive earthed part of the cabinet.
- Electronic modules or components must not be brought in contact with highly insulating materials such as plastic sheets, synthetic fiber clothing. They must be laid down on conductive surfaces.
- The tip of the soldering iron must be grounded.
- Electronic modules and components must be stored and transported in conductive packing.

Failure to follow this instruction can result in equipment damage

2.0 About this Manual

This document includes AXON taxiway inset light fixture information with a focus on safety, installation and maintenance procedures.

For more information, see www.adbsafegate.com.



Note

It is very important to read this document before any work is started.

This manual covers the following 12-inch and 8-inch light fixtures:

- ICAO Stop Bar, 12-inch and 8-inch (SB ICAO)
- FAA L-852S(L) Stop Bar, 12-inch and 8-inch (SB FAA)
- ICAO Taxiway Centerline, 12-inch and 8-inch (TWY ICAO)
- FAA L-852A/B/C/D/J/K(L) Taxiway Centerline, 12-inch and 8-inch (TWY FAA)
- Triple Line Taxiway Centerline Light, 12-inch and 8-inch (TWY 3C)
- FAA Runway Entrance Light (REL), 12-inch and 8-inch (TS)

2.1 How to work with the Manual

- Familiarize yourself with the structure and content.
- Carry out the actions completely and in the given sequence.

2.2 Abbreviations and Terms

This document may include the abbreviations and terms listed below.

Abbreviation and term	Description
AGL	Airfield Ground Lighting
ANSI	American National Standards Institute
ATM	Air Traffic Movement
CCR	Constant Current Regulator
EASA	European Union Aviation Safety Agency
FAA	Federal Aviation Administration
ICAO	International Civil Aviation Organization
IEC	International Electrotechnical Committee
IEEE	Institute of Electrical and Electronics Engineers
ILCMS	Individual Light Control and Monitoring System
LED	Light Emitting Diode
NATO	North Atlantic Treaty Organization
OFDM	Orthogonal Frequency Division Multiplexing
PWM	Pulse Width Modulation
STAC	Service Technique de l'Aviation Civile (France)
STANAG	Standardization Agreement (NATO)
UFC	Unified Facilities Criteria

3.0 Introduction

The all-in-one solution

The 12-inch and 8-inch ranges are bi- or unidirectional low protrusion light-emitting diode (LED) inset light fixtures, available in multiple versions:

Non-MON

Basic operation providing power only

MON (Fail-open)

A LED light fixture with integrated fail open technology for CCR monitoring compatibility

EQ

Fixture with integrated ILCMS remote utilizing orthogonal frequency-division multiplexing (OFDM) technology providing superior communication interfacing with LINC 360 System.



NOTICE

All our light fixtures are equipped with failed LED detection monitoring as required by FAA Engineering Brief 67.

Figure 1: 8-Inch and 12-inch Taxiway Insets

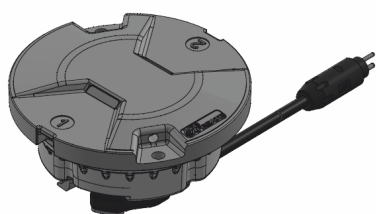

Taxiway Inset 8"
2-bolt version
(4-bolt not shown)

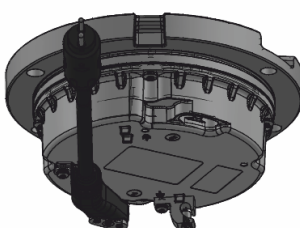

Taxiway Inset 8" with
Style-1 jacketed cord set

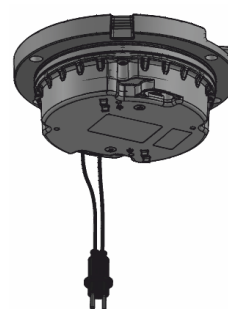

Taxiway Inset 8" with
Style-6 cord set

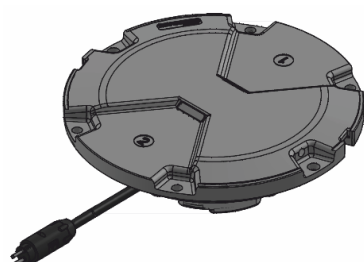

Taxiway Inset 12"

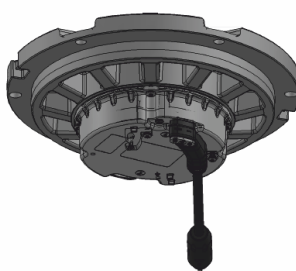

Taxiway Inset 12" with
Style-1 jacketed cord set

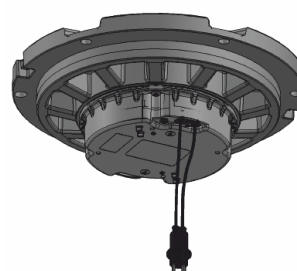

Taxiway Inset 12" with
Style-6 cord set



Note

EQ light fixtures are not fail-open light fixtures. The monitoring as well as the control functionality is handled by the ILCMS system.

3.1 Product Information

Compliance and Standards

Compliance	Description	Application:					
		SB ICAO	SB FAA	TWY ICAO	TWY FAA	TWY 3C	TS
Reference DS-XXXX:		5049	5050	5051	5052	5054	5070
FAA	AC 150/5345-46 and the FAA Engineering Brief No. 67		X		X		X
ICAO	Annex 14 Volume 1	X		X			X
EASA	CS-ADR-DSN	X		X			
Australia	MOS 139	X		X			
Canada	TP 312	X		X			
IEC	61827	X		X		X	
NATO	STANAG 3316	X		X			
STAC	PRO/STAC/SE/VIS	X		X			
CE		X	X	X	X	X	

Uses SB ICAO

ICAO

- Stop Bar

Uses SB FAA

FAA and UFC

- L-852S(L) Stop bar

Uses TWY ICAO

ICAO

- Taxiway Centerline
- Intermediate Holding Position
- Turn Pad Light
- Enhanced Taxiway Centerline

Uses TWY FAA

FAA and UFC

- L-852A(L), L-852B(L), L-852C(L), L-852D(L), L-852J(L), L-852K(L) Taxiway Centerline
- Lead-on/Exit

Uses TWY 3C

ICAO

- Triple Line Taxiway Centerline Light

Uses RS TS

FAA

- L-850T(L) Runway Takeoff/Hold and Intersection Light (THL/RIL)
- L-852S(L) Runway Entry Light (REL)

Features and Benefits

Efficiency

- EQ has an integrated ILCMS remote for use with the LINC 360 system providing high data capacity and resisting degradation from various types of radio effects to provide a superior communication platform
- Precision aimed optics enhancing photometric performance and complementing extended LED life
- Reduced bottom pan profile allowing for very shallow base can installation
- LED pulse width modulated (PWM) at 400 Hz optimizing LED performance and eliminating perceptible flicker to a moving human observer throughout the range of brightness steps
- Operates at all steps of constant current regulator technologies designed in compliance with IEC or FAA requirements
- Fully dimmable lights, conforming to the dimming curve of traditional halogen lights
- Low protrusion, high-intensity, Style 3 (≤ 6.35 mm) inset light fixtures
- No negative slope in front of the prisms

Sustainability

- Fully encapsulated all-in-one universal power supplies for Runway, Taxiway, Approach and Omni inset families
- Latest generation LEDs providing a long-lasting light source with high efficiency and low power consumption
- Reinforced top cover substantially exceeding standards to improve durability and longevity (directional beams only)
- One single family of fixtures covering all runway, taxiway and approach applications
- IP68 rated enclosure designed for harsh environments; all fastenings are stainless steel
- Reinforced prism available as an option
- Compatible with existing infrastructure allowing for direct replacement of existing LED inset fixtures

Safety

- Improved mechanical design to strengthen and consolidate components, improving the customer maintenance experience
- Fail-open option for compatibility with legacy monitoring systems and optimization of advanced control and monitoring systems
- Failed LED Detection as required by Engineering Brief 67D
- Robust lightning protection complying with ANSI/IEEE C62.41-1991; Location Category C2 as required by FAA Eng. Brief 67 Category C2 is defined as a 1.2/50 μ S – 8/20 μ S combination wave, with a peak voltage of 10,000 V and a peak current of 5,000 A

Power Supply Options

- Non-Monitored — Power only
- Monitored — Integrated Fail-open technology
- EQ with integrated ILCMS with OFDM technology for use with LINC 360 system

Maintenance and Installation

The light fixture can be installed on a 12-inch or an 8-inch base. Gaskets are sold separately. Check what gasket and bolts to order depending on base and installation. Refer to the interoperability section of the user manual for installation on a specific base.

Operating Conditions

Operating temperature	-60 °C to +55 °C / -76 °F to +131 °F
Storage temperature	-60 °C to +80 °C / -76 °F to +176 °F
Humidity	Up to 100%

3.2 Dimensions and Weight

Weight	Dimension
3 kg / 6.6 lb (8 in)	203 mm / 8 in
6.8 kg / 15 lb (12 in)	304 mm / 12 in

Figure 2: 8-inch Taxiway Lights

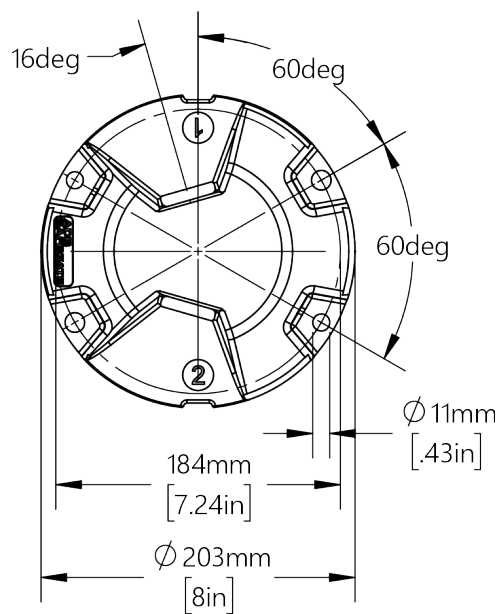
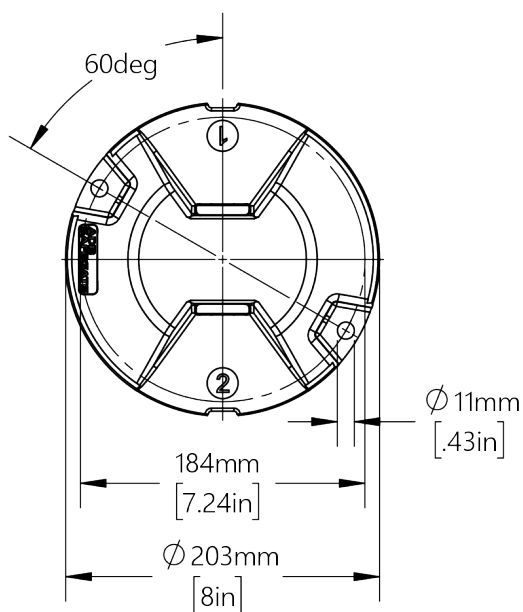
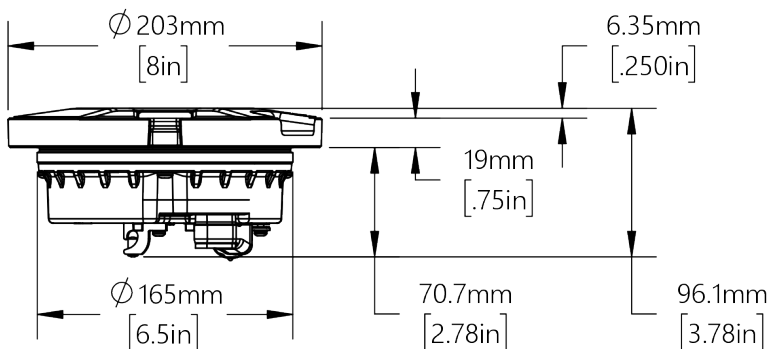
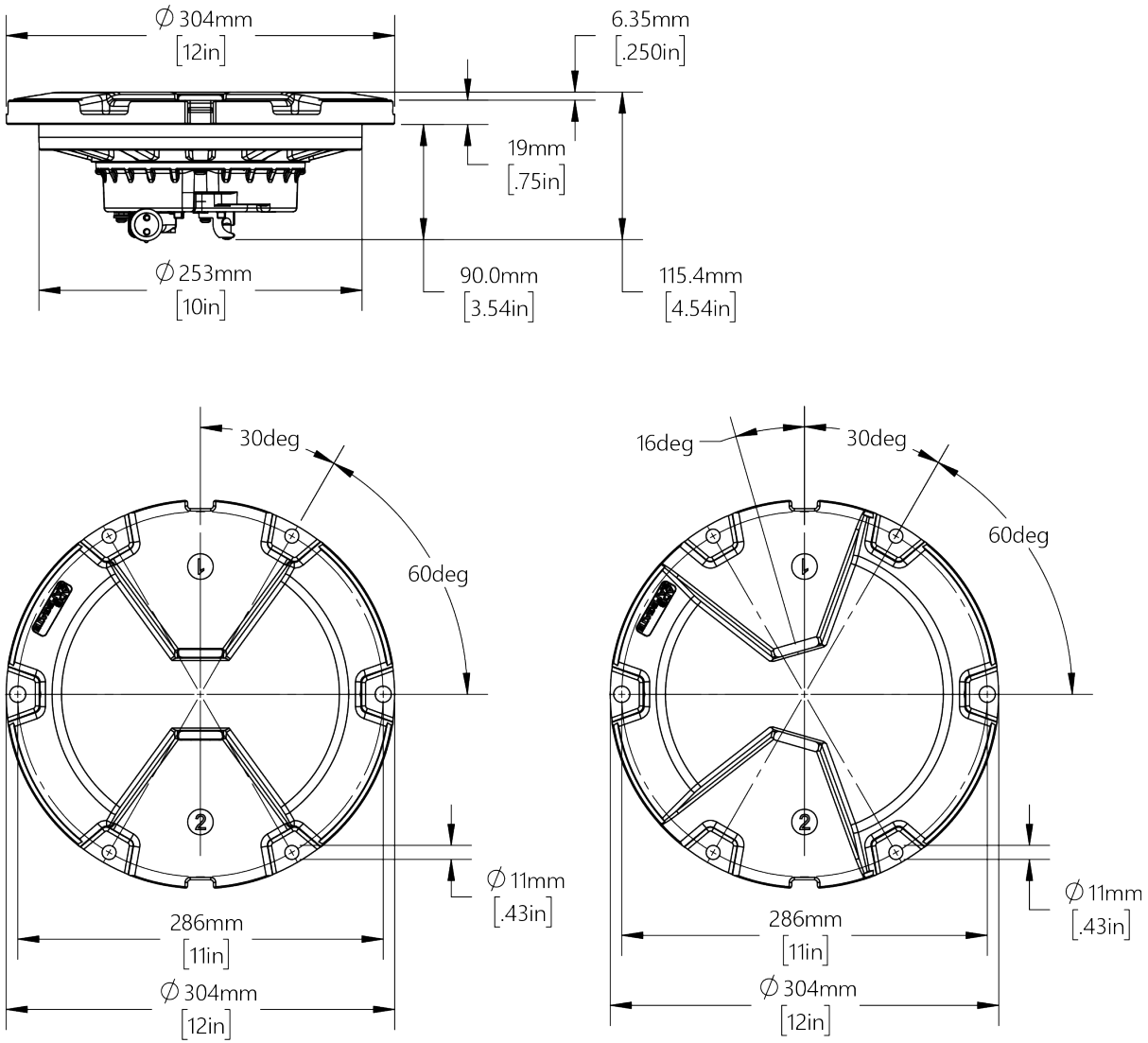

Figure 3: 12-inch Taxiway Lights



4.0 Installation

Install the inset light fixture in a base provided by ADB SAFEGATE.



Note

If the inset light fixture is to be installed on another type of base or adapter ring not provided by ADB SAFEGATE, contact ADB SAFEGATE.



CAUTION

Use of incorrect combination of gaskets, bolts and nuts can cause severe damage to the product and create multiple safety risks.

To obtain a safe and watertight installation, the O - ring and retaining bolt stated in this document must be used.

In order to choose the correct gasket, bolts and nuts, you need to know what base the light fixture will be installed on.

4.1 Safety Considerations

Read the installation section of all system component manuals before starting these steps. A thorough understanding of system components and their requirements will promote safe and efficient installation. See FAA AC 150/5340-30, Design and Installation Details for Airport Visual Aids, and site plans and specifications for field installation of runway and taxiway in-pavement lights.



DANGER

FAILURE TO FOLLOW THESE SAFETY PROCEDURES CAN RESULT IN PERSONAL INJURY OR DEATH.

- ALLOW ONLY QUALIFIED PERSONNEL TO INSTALL ADB SAFEGATE AND AUXILIARY EQUIPMENT. USE ONLY APPROVED EQUIPMENT. USING UNAPPROVED EQUIPMENT IN AN APPROVED SYSTEM MAY VOID FAA APPROVALS. OBSERVE AND FOLLOW THE SAFETY INSTRUCTIONS IN THIS DOCUMENT AND ALL OTHER RELATED DOCUMENTATION.
- MAKE SURE ALL EQUIPMENT IS RATED AND APPROVED FOR THE ENVIRONMENT WHERE IT IS BEING USED.
- FOLLOW ALL INSTRUCTIONS FOR INSTALLING COMPONENTS AND ACCESSORIES.
- INSTALL ALL ELECTRICAL CONNECTIONS IN COMPLIANCE WITH LOCAL AND NATIONAL CODES AND REGULATIONS.
- USE ONLY ELECTRICAL WIRE OF SUFFICIENT GAUGE AND INSULATION TO HANDLE THE RATED CURRENT DEMAND. ALL WIRING MUST MEET LOCAL AND NATIONAL CODES.
- ROUTE ELECTRICAL WIRING ALONG A PROTECTED PATH. MAKE SURE IT WILL NOT BE DAMAGED BY MOVING EQUIPMENT.
- PROTECT COMPONENTS FROM DAMAGE, WEAR AND HARSH ENVIRONMENTAL CONDITIONS.
- ALLOW AMPLE CLEARANCE FOR MAINTENANCE, PANEL ACCESSIBILITY AND COVER REMOVAL.
- PROTECT EQUIPMENT WITH SAFETY DEVICES AS SPECIFIED BY APPLICABLE SAFETY REGULATIONS.
- IF SAFETY DEVICES MUST BE REMOVED FOR INSTALLATION, REINSTALL THEM IMMEDIATELY AFTER THE WORK IS COMPLETED AND CHECK THEM FOR PROPER FUNCTIONING.
- THE CORD SET MUST BE PROTECTED PRIOR TO INSTALLATION.

4.2 Photobiological safety



CAUTION

Photobiological safety conforming with IEC 62471

RISK GROUP 0 or 1: Optical radiation emitted from LED lights may be harmful to the eyes. Do not stare with at the light source with bare eyes at a fixture operating at high intensity. Use protection goggles or similar protection method.

Goggles with a transmission factor not higher than 5% in the 400-530 nm band have been tested and provide adequate protection.

4.3 Inspect on delivery

1. Inspect all packaging for visible damage.
2. If damage is detected on packaging, open the damaged box and inspect its contents for damage.
3. If containing product is damaged, immediately fill a claim form with the carrier.
4. Store the fixture in its original packing in a protected area.

4.4 Unpack the Unit



CAUTION

Do not unpack the fixture until it is at the installation site to avoid damage due to transportation and handling.

Open the box and verify that the characteristics of the light fixture correspond to the design requirements, such as type, color etc. When installing a light fixture where the control and monitoring function is to be activated at a later stage, make sure to register product information, such as PID/SN and position of the light fixture in, for example, a site documentation table. The information is required for remote activation and administration of control and monitoring functionality from a substation.

4.5 Verify Input Requirements and Equipment Needed

The In-pavement light fixture is designed for connection to a 6.6A or 20A series lighting circuit via an L-830 (60 Hz) or L-831 (50 Hz) isolation transformer.

Make sure you have the necessary tools and materials ready for installation (not supplied). Also consider other tools that might be needed based on site-specific conditions.

4.6 Installation Overview



WARNING

Read the instructions in their entirety before starting installation.

This section provides instructions for installing the in-pavement lights. Refer to airport project plans and specifications for specific installation instructions. The installation must conform to the applicable sections of the National Electric Code and local codes.

4.6.1 Tools Required

The following tools are recommended for installation:

- Drill / driver with 21 mm (9/16-inch) socket
 - Torque wrench with 21 mm (9/16-inch) socket (Do not use an impact wrench)
 - Two large flat head screwdrivers to lift edge of fixture to reposition if necessary
 - Air compressor with high pressure nozzle - Optional to assure mounting surface is free of debris
 - One brush or cloth
-



Note

Provided the base has been properly installed, no other tool is required.

4.6.2 Installation

On a shallow base

The 8-inch and 12-inch diameter shallow base is secured in the pavement by means of resin. Correct positioning is obtained with a leveling jig with a sighting telescope. Wires between the light and the series transformer are installed either in saw cuts in the pavement filled with resin or in pipes in the lower concrete layers. Mounting an 8-inch light fixture in a 12-inch diameter base is made possible by means of dedicated adapter rings.

Figure 4: Installation on shallow base

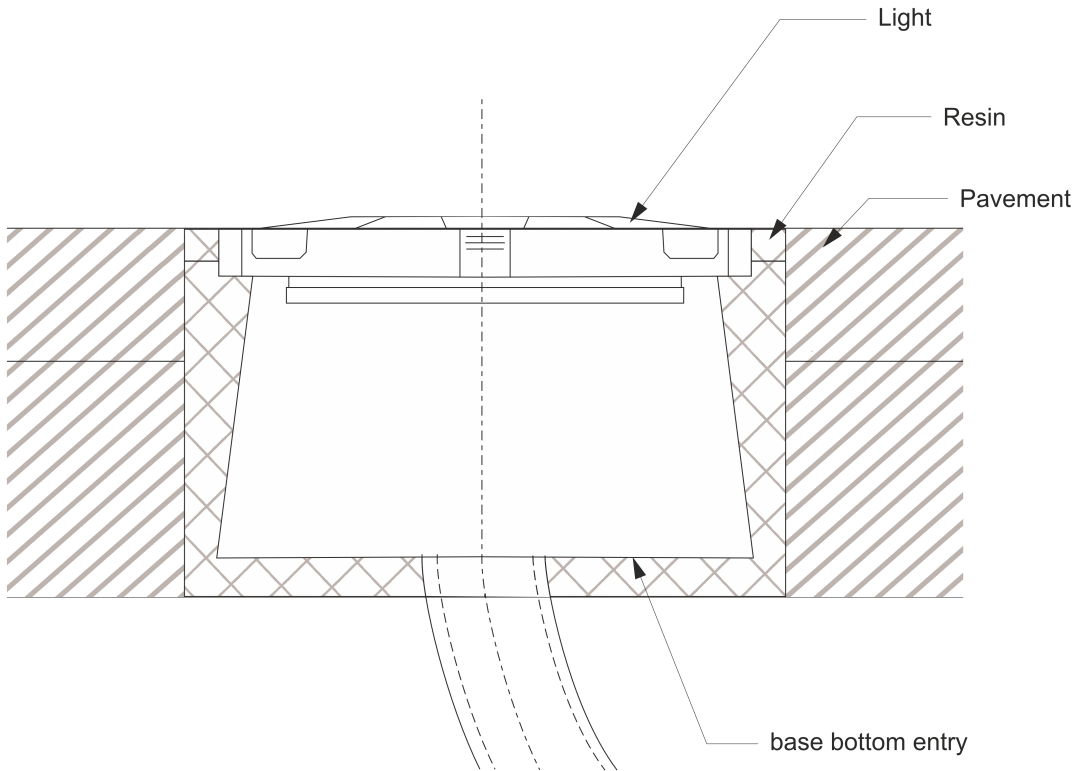

On an FAA L-868B size B steel base

The 12-inch light fixture is installed in a 12-inch base. The 8-inch diameter light can be installed in an 8-inch base or, with the use of a snow ring or an adapter ring, in a 12-inch base. The bases are interconnected by means of conduits protecting the cables. The series transformer is installed under the light or in a separate pit. See data sheet A.05.120 or DS-2012 for more information on base cans.

4.6.3 Typical L-868 Assembly

Fixture Installed in a 1-Piece Base Can	Call-out Numbers) Description
	1) 3/8-16 Hex Cap Screw (per FAA EB-83 (latest revision))
	2) 3/8" Anti-vibration Washer (per FAA EB-83 (latest revision))
	3) Fixture Top Edge to be $+0/-1/16$ " Below Grade
	4) 0.75"
	5) Ground Wire
	6) Isolation Transformer Size as Required
	7) 3/4" Drain Hole (Centered)
	8) Transformer Support (Typ.)
	9) 2" PVC Conduit with Bell End
	10) Grommet
	11) L-823 Primary Connector (Typ.) (Heatshrink Optional)
	12) L-823 Secondary Connector
	13) L868B Light Base
	14) 1-1/2" (Typ.)
	15) L868B Spacer Ring(s) In order to maintain $+0/-1/16$ " below grade, per FAA installation tolerance, a maximum of 3 spacers may be used.
	16) 1/4" Wide X 1-1/2" Deep Groove (Typ.)
	17) L868B Flange Ring 12.25" O.D. 3/4" Thick, 5402/12Y With O-Ring Gasket (Typ.)
	18) Semi-Flush Light Fixture Type L-85X (Typ.)



Note

Torque according to: FAA EB-83 (latest revision).



CAUTION

Per FAA AC 150/5340-30, Chapter 10, and FAA Engineering Brief No 83 (latest revision), it is extremely important that other types of washers, such as split washers, not be used. Failure to use properly installed anti-vibration lock washers will cause mounting bolts to become loose. The cams (or steps) of each half of the lock washer must face each other.

Figure 5: Anti-vibration washer example

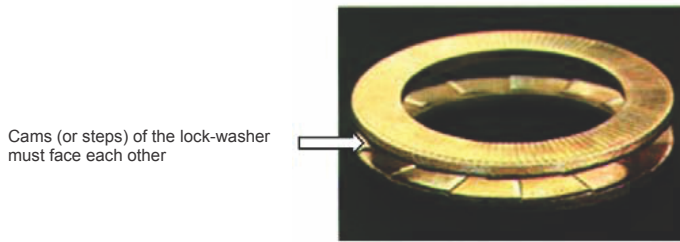

4.6.4 Configuration

To learn more about updating or configuring our EQ light fixtures equipped with internal ILCMS remote and sensor technology, please refer to our [LINC360 manuals](#). These comprehensive guides cover firmware updates, configuration options and instructions on integrating EQ lights into the ILCMS system.

4.6.5 Installation and Removal of the Inset Light Fixture



WARNING

Read the instructions in their entirety before starting installation.



Note

Top cover versions:

please check [interoperability](#) matrix for information on compatibility to different bases and torque values.

This section provides instructions for installing the in-pavement lights. Refer to airport project plans and specifications for specific installation instructions. The installation must conform to the applicable sections of the National Electric Code and local codes.

Install the light fixture in a base, class 1, direct-mounted fixture.

Figure 6: 12-inch shallow base, class 1, direct-mounted fixture

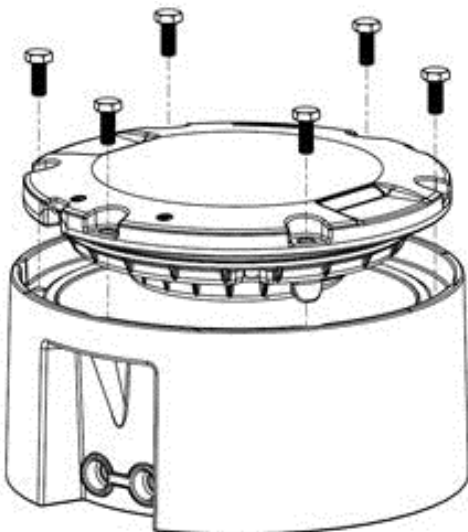

1. Carefully clean all contact surfaces of the light fixture and the base.
2. Put the O-ring gasket in the gasket track on the base. (Not for class 2)

3. Mount light fixture to the base.



Note

Make sure the secondary cables are inside the base and not pressed between the light and the base.

4. For installation on a base, use a torque limiting box spanner of 16/17 mm to install and tighten the fixing bolts or nuts to a torque value according to specification. Make sure the light fixture functions properly before the next step. See [Interoperability](#). For other base manufacturers, refer to their specifications.



Note

Do not use high speed for tightening the fixing bolts. The recommended speed is 10 - 40 rpm. Do not use an impact driver/wrench.

5. In order to bond the light fixture to the ground, use a ground lug or grounding screw (torque 2.5 Nm) to attach the braided ground strap or wire to the grounding point on the light fixture. The grounding point is indicated by a grounding symbol that is located on the bottom side.

Remove the fitting from the base



CAUTION

Fall- and trip hazard!

When a light fixture has been removed, the base must be fitted with a cover designed for this purpose or with a spare light fixture.

1. Using two large flat blade screwdrivers carefully remove the light fixture from its base .
2. Disconnect the secondary supply connector.
3. Remove and check the gasket (O-ring or labyrinth).



Note

It is recommended to change the gasket, lock nuts or bolts each time the light fixture is removed or dismantled from the base. For more information, see INTEROPERABILITY chapter of this manual. .



CAUTION

Use of incorrect combination of gaskets, bolts and nuts can cause severe damage to the product installation and create multiple safety risks.

Verify what base the light fixture will be installed in, in order to choose the correct gasket, bolts and nuts.

Failure to follow these cautions can result in equipment damage or aircraft FOD.

4.6.6 Test the Light Fixture for Leaks (Water-tightness)



Note

A compressor, or a manual car tire pump, equipped with a manometer is required to check the light fixture for watertightness.

Tools to be used:

- Flat head screwdriver
- Pressure test fitting tool to be used (pt no.44A6104/A) for watertight testing

1. Remove the pressure release screw and discard.

Figure 7: Pressure Release Screw

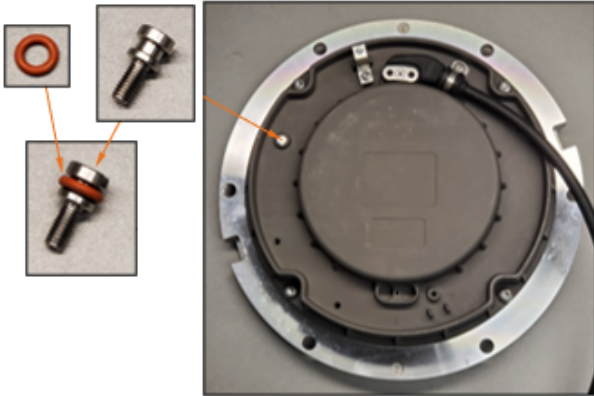

2. Screw the pressure test fitting tool hand-tight into the pressure-relief port (the opening from where the pressure release screw was removed).

Call-out) Description	
<p>Figure 8: Pressure Test Fitting Tool</p>	<p>Figure 9: Pressure Test Fitting Tool</p>
	<p>1) Pop — safety valve</p> <p>2) 90 deg., elbow, female X male, brass, 1/4"</p> <p>3) Adapter, female — male, 1/4 x 1/8, brass</p> <p>4) Sleeve — lock hose plug, 1/4" coupler</p> <p>5) Tee, brass, 1/8</p> <p>6) Pressure test fitting, body</p> <p>7) O-ring, silicone, size 008, 1/16 W X 3/16</p> <p>8) M4 Hex Jam nut, 18-8 SS</p> <p>9) Pressure test fitting stud</p>

3. Attach the shop airline (4) to the lock hose plug sleeve.
4. Pressurize to 20 psi (130 kPa).
5. Submerge the pressure test fitting into a water tank.

6. Wait 3 minutes and check if air leaks out between:

- The bottom pan and the top cover
- The prism and the top plate
- The watertightness valve and top plate

If air leaks out of the light fixture, it is not watertight and must be repaired:

- Release the air from the light
- Disassemble the light fixture
- Re-check the mating surfaces and gaskets
- Re-assemble the light fixture
- Return to step 1

7. If the fixture is watertight, depressurize and install a new pressure release screw (see [Figure 7](#)) at 26 in-lbs (3 Nm).



DANGER

NEVER EXCEED A PRESSURE OF 22 PSI (150 KPA) INSIDE THE LIGHT FIXTURE. A HIGHER PRESSURE MAY CAUSE INJURIES AND DAMAGE THE LIGHT.

4.7 Toe-In

Taxiway light fixtures are either straight or provided with a mechanical toe-in as shown below

Straight light fixtures

These light fixtures have a straight light beam

Light fixtures (with mechanical toe-in)

These light fixtures have a curved top cover that directs the light beam at an appropriate angle

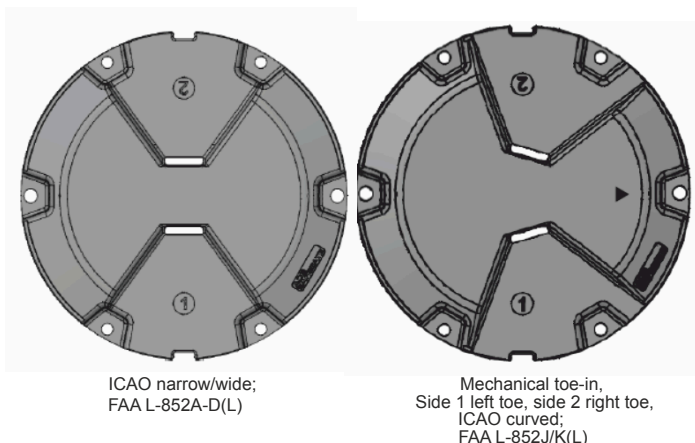
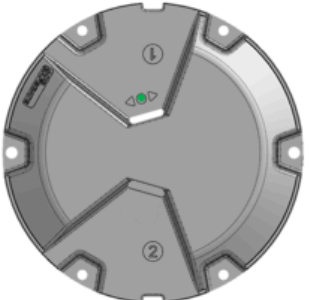

Figure 10: Toe-in



4.7.1 Definition of Light Emission Directions

The color of the emitted light is indicated with a painted dot on the top cover in front of the prism. Toe-in is per the stamped directional arrow.

Figure 11: Light emission directions

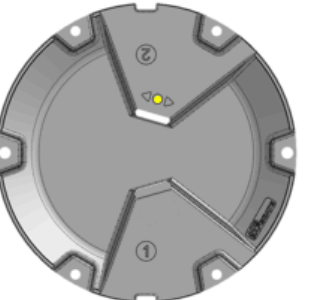
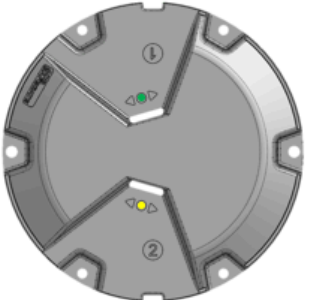
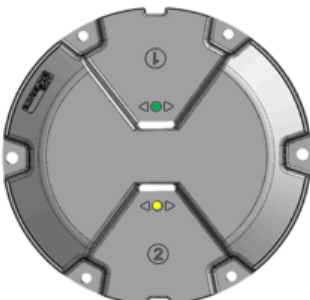
<p style="text-align: center;">Left</p> 	<p style="text-align: center;">Straight (Uni)</p> 	<p style="text-align: center;">Right</p> 
<p style="text-align: center;">Curved</p> 	<p style="text-align: center;">Straight (Bi)</p> 	
Color	Color Code	
W	White	
Y	Yellow	
F	Green	
G	Green/Cyan	
R	Red	
B	Blue	
A	Amber/Orange	

5.0 Maintenance

This section describes different steps for maintenance of the light fixture.

Before you start, make sure you have read and understand [Safety instructions](#).

Find out the location of the light unit that needs maintenance. If the purpose is to replace an existing light unit with new one, make sure that corresponding unit is available. Find the type information on the identification tag with details of name.

Spare parts are available, if required. For more information, see www.adbsafegate.com and the Spare Parts List document, or contact ADB SAFEGATE for assistance.



CAUTION

Use of incorrect combination of gaskets, bolts and nuts can create severe damages to the product installation and create multiple safety risks.

You need to know what base the light fixture will be installed in, in order to choose the correct gasket, bolts and nuts.

Failure to follow these cautions can result in equipment damage or aircraft FOD. For more information, see [Interoperability](#).



CAUTION

When a light fixture has been removed from its base, the base must be either fitted with a cover or a spare light fixture put in its place. It is recommended that only authorized personnel disassemble fittings with prior agreement from ADB SAFEGATE.

5.1 Basic Maintenance Program

It is important to understand that even though a LED fixture requires substantially lower maintenance in regard to the replacement of the light bulbs, some parts of the light fixture remain the same and still require the same level of maintenance (prisms, top cover, bolts).

There are recommended maintenance tasks to ensure that the equipment is in correct operating condition.

Table 1: Maintenance tasks

Weekly	<ul style="list-style-type: none"> Visual inspection of the light fixture. Removal of dust from external surfaces of the light fixture.
Monthly	<ul style="list-style-type: none"> Check optical window for cleanliness, mechanical damage or moisture/condensation on the inside of the prism Check for improper torque on mounting bolts. Re-torque if needed.
Yearly	<ul style="list-style-type: none"> Detailed inspection of the light fixture Check of the body resistance, check for mechanical damage (for example cracks around the prism windows). Clean optical windows
Bi-yearly	<ul style="list-style-type: none"> Check for presence of water in mounting support by unscrewing and lifting light fixture from base and check for water ingress and corrosion. Replace gasket between light fixture and base.
After snow removal	<ul style="list-style-type: none"> Check for damaged light fixtures. Any damaged light fixtures should be replaced and brought in and properly investigated and repaired.

A daily function check is referred to in the document:

ICAO, *Airport Services Manual Part 9, Airport Maintenance Practice* and FAA AC 150/5340-26A, *Maintenance of airport visual aids facilities*.

Any issues found during maintenance tasks should be corrected accordingly and properly documented.

A proper asset management system such as ADB SAFEGATE's CORTEX Service can help to store/document data and can provide valuable information on local presiding conditions for preventive maintenance planning. This can then be used to minimize the need for reactive maintenance.

CORTEX Service, ADB SAFEGATE's new digital asset tracking, inspection and service solution, helps airports easily register airside assets, electronically schedule and track maintenance, and record maintenance and inspection tasks in compliance with ICAO and FAA standards.

Visit <https://adbsafegate.com/services/airside-maintenance/>



5.2 Recommended Maintenance Program for Optimal Service Life

Service Life and Inspection Intervals

All products have an expected service life. Service life is the lifetime of the product and reaching the end means that it is no longer serviceable and should be replaced.

There are several key external factors that influences the service life of a product.

- Aircraft traffic movements
- Location on the airfield
- Maintenance
- Chemical usage

Air Traffic Movements (ATM)

The expected lifetime of a light fixture will be highly impacted by the traffic volume and the number of aircraft that are mechanically putting stress on the light fixtures. Airports with a higher traffic volume will have a light fixture with a shorter expected lifetime than an airport with a lower traffic volume.

The ATM can be divided into three categories for the recommendation of inspections as well as for the expected lifetime of a light fixture¹.

- 0-100k movements/year
- 100k-200k movements/year
- >200k movements/year

Location on the Airfield

The expected lifetime of a light fixture is highly dependent on the location where it is installed on an airfield. Three different areas have been defined by color categorization that are exposed to a different degree of mechanical impact. These three categories are used as a basis for the recommendation of inspections as well as for the expected lifetime of a light fixture.

- **Red** – Touch Down Area defined as 6m from either side of the runway centerline for a distance starting from 50m before the TDZ markings and extending to 200m beyond the TDZ markings as seen from the landing direction.
- **Red** – Rapid Exit Taxiway centerline lights from the runway centerline to 50m beyond the edge of the runway.
- **Amber** – All runway areas outside the Red areas.
- **Amber** – All taxiway areas outside the Red areas, including taxiway intersections for which more than 50% of the aircraft traffic turn more than 45 degrees.
- **Green** – Areas outside Red and Amber areas



NOTICE

A reliable means of recording the location history of fittings (i.e. ADB SAFEGATE's CORTEX Service) is recommended to ensure that the maximum duration in critical red areas of the runway is not exceeded.

¹Based on ADB SAFEGATE's field experience and investigation made together with an independent consultant and airport.

Preventive Maintenance

Preventive maintenance and inspections will help to prolong the service life of a light fixture. By finding issues (e.g., bad gaskets or broken prisms) at an early stage you can mitigate and fix issue before they cause more damage and reduce the cost of the repair. You can also increase the service life of a light fixture by rotating the installation location of light fixtures in critical areas.

Regular inspections and well-defined preventive maintenance planning will help to reduce the overall maintenance cost and reduce downtime from reactive maintenance tasks.

Figure 12: Preventive Maintenance

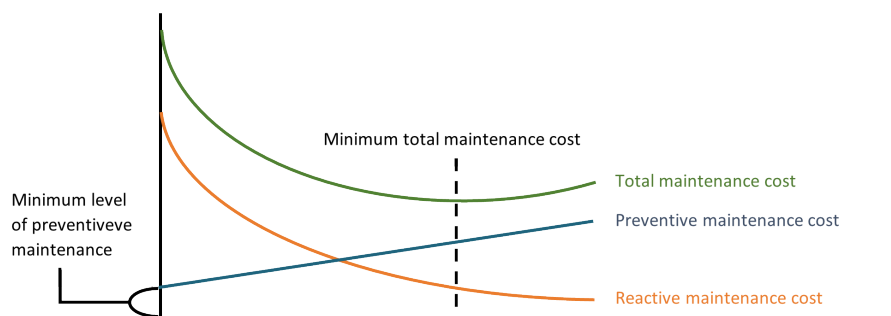

5.2.1 Recommendation

Based on the air traffic volume and location on the airfield, a matrix was created for recommended inspection intervals presented in Figure 13.

Figure 13: Visual Inspection Interval

Location	RED	Amber	Green
ATM			
0-100k movements	2 Months 1 Year	6 Months 3 Years	1 Year 3 Years
100k-200k movements	2 Months 1 Year	4 Months 2 Years	1 Year 3 Years
Above 200k movements	1 Months 6 Months	2 Months 1 Year	1 Year 3 Years

Inspection interval

Visual inspection

Visually inspect the light fixture and make sure that:

- Prism is clean and no cracks are visible
- Gaskets are ok and are not deteriorating
- No moisture or condensation can be seen on the inside of the prism
- Corrosion on top cover, around the prism and bolts.
- Torquing of nuts/bolts are according to specification

Detailed Inspection

Includes visual inspection tasks and additionally the following tasks:

- Unbolt the light fixture and lift it from the base for the detailed inspection
- Check for water ingress (watertight installation) and corrosion on light fixture and base (especially around the mating surfaces)
- For deep base installation (L-868) check for water ingress, if more than 6 inches please have it removed.
- Inspect light and base for damage

- Replace gasket between light fixture and base



NOTICE

We recommend any maintenance work that requires the light fixture to be opened to be done back in the dedicated maintenance area.

- We recommend that inspection intervals are halved for aging units that have reached more than 75 % of their expected lifetime.
- We recommend that AGL in critical areas are rotated.
- To achieve a proper location rotation and individual asset, data needs to be recorded.
- To relax the recommended frequencies of some maintenance tasks i.e. torque management, data is needed for justification.
- Policies have a direct link with the age of the AGL and should also be tracked and recorded.

The recommended service life is presented in [Table 2](#). With a proper asset management (CORTEX Service or similar) and data capturing strategy, the guidelines presented could be extended or shortened as deemed necessary via presiding local conditions.

Table 2: Expected service life (only critical areas defined)

RED Zone -, ATM < 100k	15 years
RED Zone -, ATM > 100k < 200K	10 years
RED Zone -, ATM > 200k	7 years



Note

Contact your local sales representative if you have any questions or would require some assistance to go through local conditions and see how we can help establish a well-defined maintenance planning to optimize the expected service life of your investment.

5.3 Prism Cleaning Procedure for Inset Light Fixtures

Regular cleaning of the prisms is crucial for maintaining light quality and fixture efficiency.

Disclaimer: ADB SAFEGATE provides specific cleaning methods and recommendations for its airfield light fixtures and signs to ensure optimal performance and longevity. Any cleaning method or procedure applied to the light fixtures that deviates from the recommendations provided by ADB SAFEGATE is done at the sole discretion and responsibility of the user. ADB SAFEGATE shall not be held liable for any damage, reduced performance, or failure of the light fixtures resulting from improper cleaning practices.

Safety Precautions

1. Make sure the light fixture is turned off at the main power source to eliminate electrical hazards.
2. Use safety gloves to protect your hands and safety glasses to shield your eyes from dust and debris.

Basic Cleaning Procedure



Note

Handle the prisms with care to avoid creating chips or cracks.

1. Gently dust the prism with a soft, dry brush or cloth to get rid of any loose dirt or dust.
2. Remove any rubber build-up using a plastic scraper.
3. Apply lukewarm water mixed with a pH-neutral soap.
4. Thoroughly rinse off with water and dry prism with a soft, lint-free cloth to prevent water spots and ensure clear illumination.

Removing Stubborn Rubber Build-up or Compacted Snow

- Cleaning chemicals and/or de-icing liquids with a pH of 11 or less may be used in cases where pH-neutral soap is not enough. See [Approved Chemicals for Cleaning](#) and [Protocol for Introducing New Chemical Solutions](#).



CAUTION

The extensive application of chemical cleaners and/or de-icing liquids may damage the light fixtures and underground electrical components, leading to corrosion and increased maintenance requirements and costs.

Do not use abrasive cleaners or pads that can scratch the prism surface.



NOTICE

Sapphire prisms, can be sensitive to certain chemicals as they are made by bonding a thin sapphire slab to a glass prism. Always test cleaning chemicals for compatibility with sapphire prisms to avoid weakening the adhesive bond. See [Protocol for Introducing New Chemical Solutions](#).

- High-Pressure Water Jets may also be used for stubborn build-up ensuring the minimum distance of 165 mm (6.5 inches) is maintained and the water pressure does not exceed 80 bar (1300 psi) to prevent damage to the gaskets, high-pressure water jets may be employed for cleaning.

Figure 14: High-Pressure Water Jet Precautions



- After cleaning, gently and thoroughly dry prism with a soft, lint-free cloth to prevent water spots and ensure clear illumination.

Approved Chemicals for Cleaning

The following chemicals are tested for compatibility with ADB SAFEGATE light fixtures:

- Potassium Acetate
- Potassium Formate
- Sodium Acetate
- Sodium Formate

Protocol for Introducing New Chemical Solutions

- Verify the intended use of the chemical on similar materials and products, adhering to ADB SAFEGATE recommendations.
- Initially, conduct tests on a few units to ensure there is no damage to the light fixture or gaskets before applying the chemical to a larger installation.

Contact Information

If you have any questions or require assistance, please contact your local sales representative. We can help assess your local conditions and establish a well-defined maintenance plan to optimize the expected service life of your investment.



NOTICE

Any maintenance work that requires the light fixture to be opened should be performed in a dedicated maintenance area.

You can ensure airfield safety and visibility while maintaining the integrity and performance of the inset light fixtures by following these detailed instructions.

5.4 Workshop Maintenance

The workshop maintenance includes following:

1. Open the Light Fixture — Disconnect the Bottom Pan from the Top Cover
2. Close a Light Fixture — Connect the Bottom Pan to the Top Cover
3. Replace the Power Wire Harness
4. Replace the Light Engine Assembly
5. Replace the Prism and its Gasket
6. Replace the Top Cover Assembly
7. Replace the Bottom Pan Assembly
8. Replace the Style-6 Cord Set
9. Reset the Fail-open Converter

5.4.1 Open the Light Fixture — Disconnect the Bottom Pan from the Top Cover

Tools to be used:

- Variable-speed/Torque drill driver with T25 Torx bit
-



NOTICE

Do not use an impact driver.

- Flat-head screwdriver
1. Place the light fixture upside down.
 2. Loosen the pressure release screw.
 3. Unscrew the fixation screws.
Make sure to **dispose of the old screws** and use new screws.
 4. Lift the bottom pan without damaging the connecting wires.
-



CAUTION

Make sure you do not damage the cables when opening the light fixture.

5. Pull carefully to disconnect the wires between:
 - a. the converter and the light engine.
 - b. the converter and the heater kit(s), if the heater kit is in place.
6. Remove the gasket between the top cover assembly and the inner pan assembly.
Make sure to **dispose of the old gasket** and use a new gasket.

5.4.2 Replace the Bottom Pan Assembly

1. [Open the Light Fixture — Disconnect the Bottom Pan from the Top Cover](#)
2. Replace the bottom pan assembly.
Make sure to **dispose of the old bottom pan assembly** and use a new one.
3. [Close the Light Fixture — Connect the Bottom Pan to the Top Cover](#)

5.4.3 Replace the Power Wire Harness

Figure 15: Power harness replacement



Tools to be used:

- Screwdriver or variable-speed torque drill driver with T20 Torx bit



NOTICE

Do not use an impact driver.

1. [Open the Light Fixture — Disconnect the Bottom Pan from the Top Cover.](#)
2. Remove the LED brackets (3 M4 screws per bracket) to access the connector of the LED wire. Make sure to **dispose of the old screws** and use new screws.

Figure 16: LED bracket removal

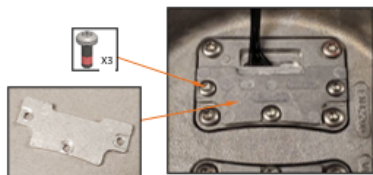

3. Disconnect the old wire harnesses. Make sure to **dispose of the old wire harnesses** and use new wire harnesses.
4. Connect the new wire harnesses.
5. Mount the LED bracket with new screws and torque at 26 in-lbs (3 Nm).
6. [Close the Light Fixture — Connect the Bottom Pan to the Top Cover.](#)

5.4.4 Replace the Light Engine Assembly

Tools to be used:

- Screwdriver or variable-speed/Torque drill driver with T25 Torx bit



NOTICE

Do not use an impact driver.

1. [Open the Light Fixture — Disconnect the Bottom Pan from the Top Cover](#)>

2. Remove the Light engine(s) (4 M5 screws per light engine assembly).
Make sure to **dispose of the old screws, light engine(s), and wire harness(es)** and the new material.
3. If equipped with heater, remove the deformed orange thermal pad.

Figure 17: Removal of Deformed Orange Thermal Pad



4. Mount the new light engine(s). If equipped with heater, the thermal pad will have a clear plastic tape that is to be removed to expose sticky surface.

Figure 18: Mounting Light Engine(s)

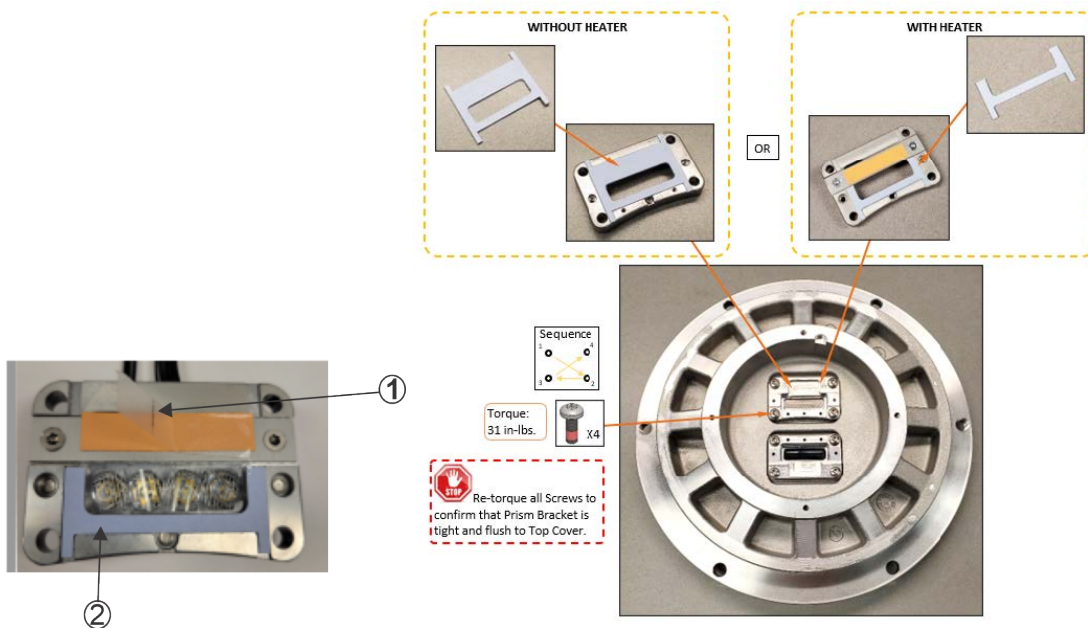

5. Carefully remove clear film to expose tacky surface of the thermal pad just prior to installation (see 1 in image above).
6. Position blue prism protection plate in channel (see 2 in image above).
7. Use new screws to attach the light engine in star pattern and torque to 31 inch-pound (3.5 Nm).
8. Retorque the screws in star pattern at 31 inch-pound (3.5 Nm).
9. [Close the Light Fixture — Connect the Bottom Pan to the Top Cover.](#)

5.4.5 Replace the Prism and its Gasket

Tools to be used:

- Screwdriver or variable-speed torque drill driver with T25 Torx bit



NOTICE

Do not use an impact driver.

1. [Open the Light Fixture — Disconnect the Bottom Pan from the Top Cover](#)>.

- Remove the Light engine (4 M5 screws per light engine assembly).
Make sure to **dispose of the old screws** and use new screws.

Figure 19: Light engine removal

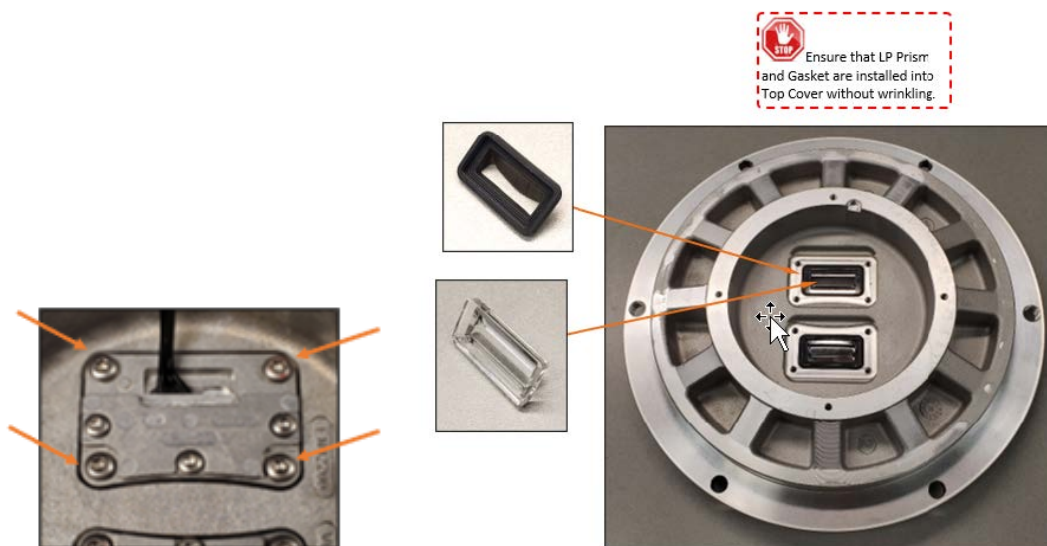

- Remove the prism the prism gasket by pushing from outside.
Make sure to **dispose of the old prisms and gaskets** and use the new material.
- Insert the new prism gasket into the top cover prism cavity.



IMPORTANT

Make sure the wider slant is oriented towards the center of the fixture.

- Insert the new prism into the top cover prism cavity.



IMPORTANT

Make sure the prism is fully flush on the outside and the prism surfaces are clean (without grease or dirt).

- Mount the light engine.
- Use new screws to attach the light engine in star pattern torquing to 31 inch-pound (3.5 Nm) and re-torque using same pattern and pressure.

Figure 20: Sequence Diagram

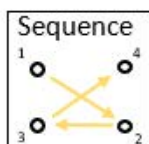

- Close the Light Fixture — Connect the Bottom Pan to the Top Cover.

5.4.6 Replace the Style-6 Cord Set

Figure 21: Secondary Cable Replacement



Tools to be used:

- Screwdriver or variable-speed torque drill driver with T20 Torx bit
- Small flat head screwdriver or Wargo inset tool, Part N : 236-332



1. [Open the Light Fixture — Disconnect the Bottom Pan from the Top Cover.](#)
2. Disconnect the secondary cable from the converter:
 - a. by placing a small flat-head screwdriver or insert tool into the opening located at the other side of the secondary wire, and
 - b. Release the cable by prying the screwdriver or insert tool on the cable release opening.
3. Unscrew and remove the strain relief bolt, the plate and the cable gland gaskets.
Make sure to **dispose of the old strain relief bolt, the plate and the cable gland gaskets** and use the new material.
4. Remove the secondary cable by using the disconnect tool on the converter.
Make sure to **dispose of the old secondary cable** and use the new secondary cable.
5. Mount the new cable gland gaskets.
6. Replacement:
 - a. Pull the secondary wires through the strain-relief plate and the cable gland gaskets and
 - b. Mount the new secondary cable by torquing the new strain-relief bolt and torque to 26 in-lbs(2.94 Nm).
7. Locking:
 - a. Lock the secondary cables leading to the converter by opening the cable holes prying a thin screwdriver or insert tool on the cable release opening and mounting the wires in place and
 - b. Lock the cables by removing screwdriver or insert tool from the opening.
8. [Close the Light Fixture — Connect the Bottom Pan to the Top Cover.](#)

5.4.7 Replace the Secondary Cable — SJO Cord Set

Figure 22: Secondary SJO cable

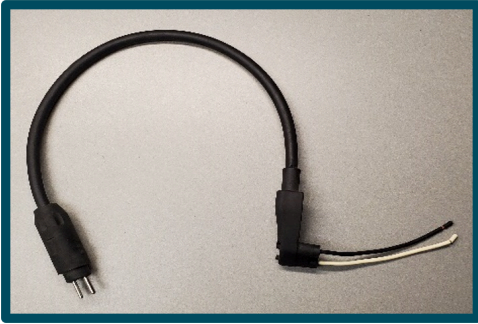

Tools to be used:

- Screwdriver or variable-speed torque drill driver with T20 Torx bit
- Small flat head screwdriver or Wargo inset tool, Part N : 236-332



1. Follow steps 1-6 in [Replace the Style-6 Cord Set](#)
2. Tighten the new cable clamp bolt with the washer and lock washer and torque to 26 in-lbs (2.94Nm)
3. Locking:
 - a. Lock the secondary cables into the converter by opening the cable holes prying a thin screw driver or insert tool on the cable release opening and removing the wires in place
 - b. Lock the cables by removing screw driver or insert tool from the opening.
4. [Close the Light Fixture — Connect the Bottom Pan to the Top Cover.](#)

5.4.8 Resetting the Fail-open Converter

Parts

- Fuse resistor spare part kit: SP.EZ00015-000-01(20 pcs)

Info

- Converters with 1 connector have 2 fuse resistors.
- Converters with 2 connectors have 4 fuse resistors.

1. Reset / replace the fuse resistors
 - a. Disconnect and disassemble the light fixture.
 - b. Locate the fuse resistors.

Figure 23: 1-connector

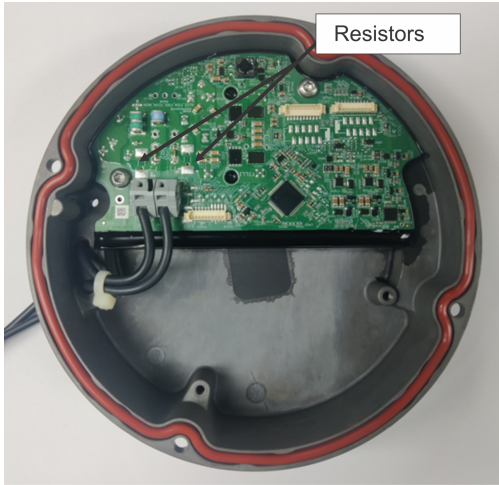
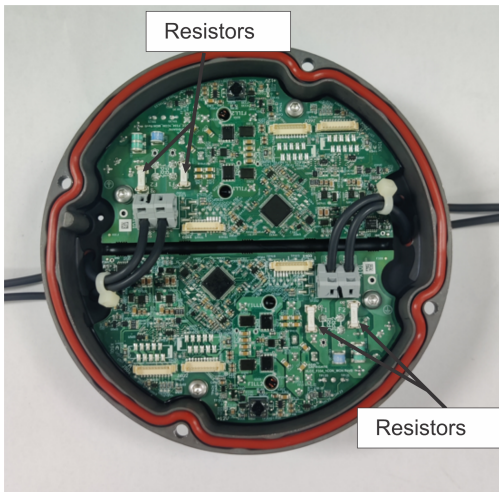

Figure 24: 2-connector



2. Remove the fuse resistors by pulling away from the converter and place the new fuse resistors in the sockets. Make sure to **dispose of the old fuse resistor**.



Note

- a. For fail-open with 1 connector, always replace both fuse resistors at the same time.
- b. For fail-open with 2 connectors, always replace both fuse resistors related to the channel that needs to be reset. (Make sure you replace all 4 fuse resistors, if both channels needs a reset.)

3. Assemble the light fixture and perform a functional test.

5.4.9 Replace the Top Cover Assembly

Tools to be used:

- Screwdriver or variable-speed torque drill driver with T25 Torx bit
 - Flat-head screwdriver
1. [Open the Light Fixture — Disconnect the Bottom Pan from the Top Cover](#)>

- Remove the Light Engine(s) (4 M5 screws per light engine assembly).

Figure 25: Light engine removal

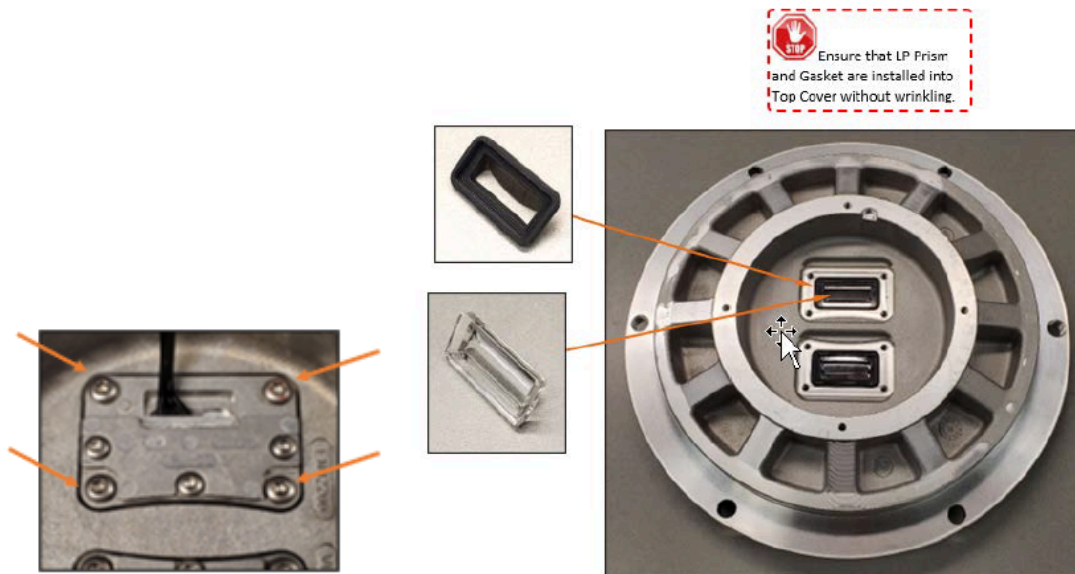

Make sure to **dispose the old screws and the old top cover** and use the new material.

- Replace the old top cover with new top cover assembly.
- Mount the light engine(s) onto the new top cover assembly.
- Use new screws to attach the light engine in star pattern torquing to 31 inch-pound (3.5 Nm) and re-torque using same pattern and pressure.

Figure 26: Sequence Diagram

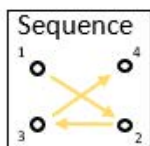

- Close the Light Fixture — Connect the Bottom Pan to the Top Cover

5.4.10 Close the Light Fixture — Connect the Bottom Pan to the Top Cover



Note

Replacement light engines are provided with the power wire harness installed.

Tools to be used:

- Variable-speed/Torque drill driver with T25 Torx bit



NOTICE

Do not use an Impact driver.

- Flat-head screwdriver
- Clean all the contact surfaces of the light fixture and of the housing carefully.

2. Press the gasket (located between top cover and inner pan) into the O-ring Groove.
Make sure the gasket placed correctly.



IMPORTANT

The O-ring Gasket must always be changed when the fixture is disassembled.

3. Connect the wires:
 - a. Press carefully to connect the wires lead in from the light engine on the converter.
 - b. Press carefully to connect the wires lead in from the light engine on the converter, if the heater kit is in place.
4. Put the Top Cover onto the Bottom Pan.
Make sure the poke-yoke (alignment pin) is in the correct position.

Figure 27: Top Cover Placement



IMPORTANT

Do not pinch the wires or the gasket.

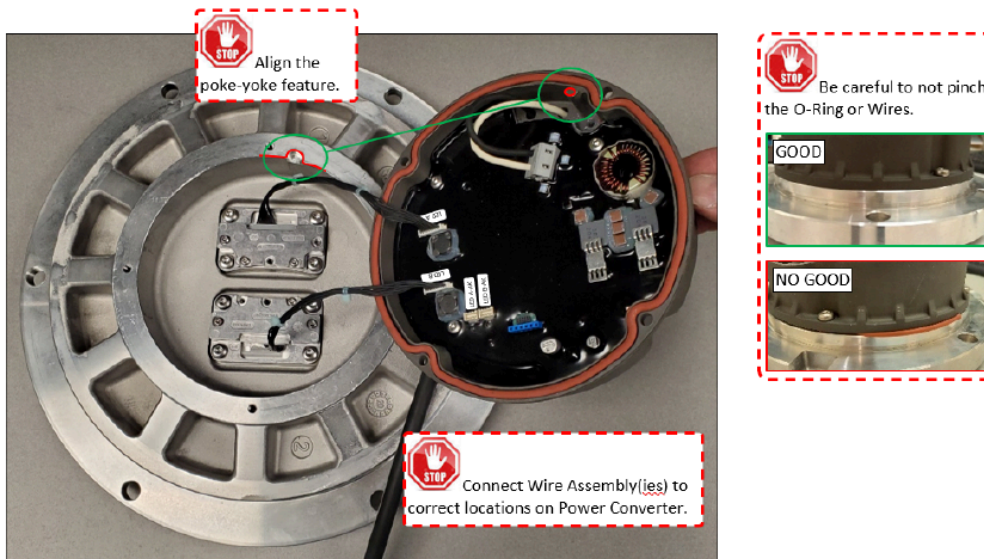

5. Put the light fixture on a surface with the top cover facing down.
 6. Torque:
 - a. Use new fixation screws to torque in star pattern at 31 in-lbs (3.5 Nm).
 - b. Retorque the screws in star pattern at 31 in-lbs (3.5 Nm).
 7. Follow the water-tightness test procedure.
-



Note

Refer to the [Test the Light Fixture for Leaks \(Water-tightness\)](#) section.

6.0 Ordering Codes

6.1 L852-A/B/C/D/J/K-(L), LED Taxiway Centerline, Lead-on/Exit, Apron Lead-in (FAA)

Ordering Code

	Application	Standard(s)	Market Specific	Dimensions	Prism	Beam Orientation	Toe-in	Color - Side 1 (Left)	Color - Side 2 (Right)	Power and Monitoring	Connector and Cable ⁴	Options	Version
RS	<input type="checkbox"/>	<input type="checkbox"/>	<input type="checkbox"/>	<input type="checkbox"/>	<input type="checkbox"/>	<input type="checkbox"/>	<input type="checkbox"/>	<input type="checkbox"/>	<input type="checkbox"/>	<input type="checkbox"/>	<input type="checkbox"/>	<input type="checkbox"/>	<input type="checkbox"/>

Application

TA = L-852A(L) Taxiway Centerline
 TB = L-852B(L) Taxiway Centerline
 TC = L-852C(L) Taxiway Centerline
 TD = L-852D(L) Taxiway Centerline
 TJ = L-852J(L) Taxiway Centerline
 TK = L-852K(L) Taxiway Centerline

Standard(s)

2 = FAA

Market Specific

0 = None

1 = Buy American Preference (BAP)¹²

Dimensions

1 = 8 inch (203 mm) diameter, 2 bolt
 2 = 12 inch (305 mm) diameter, 11.25 inch BC (285 mm)
 3 = 8 inch (203 mm) diameter, 4 bolt

Prism

S = Standard prism⁸
 R = Reinforced prism⁸

Beam Orientation

1 = Unidirectional
 2 = Bidirectional

Toe-in

N = Not Applicable (TA, TB, TC, TD applications)
 C = Curved (TJ, TK Applications)

Color - Side 1 (Left)

F = F-Green (ICAO, default green)
 Y = Yellow
 R = Red^{6, 8}
 W = White^{6, 8}
 N = None⁷

Color - Side 2 (Right)

F = F-Green (ICAO, default green)
 Y = Yellow
 R = Red^{6, 8}
 W = White^{6, 8}
 N = None

Power and Monitoring

S = 2.8 - 6.6 A, Non-Monitored — Power Only
 M = 2.8 - 6.6 A, Fail-Open Monitoring
 R = 2.8 - 6.6 A, EQ Integrated LINC 360³

Connector and Cable⁴

1 = 1 x Style 6 2-Pole Plug, 2 Individual Wires
 2 = 1 x Style 1 2-Pole Plug, Jacketed SO 2 Core Cable⁵
 3 = 2 x Style 6 2-Pole Plug, 2 Individual Wires⁸
 4 = 2 x Style 1 2-Pole Plug, Jacketed SO 2 Core Cable⁵
 5 = 1 x Flat 3-Pole Plug, 3 Individual Wires
 6 = 2 x Flat 3-Pole Plug, 3 Individual Wires

Options

0 = None
 1 = Arctic Kit

Version

1 = Version 1

Ordering Code Notes

1. Required for FAA when funded by AIP.
2. If a 2-cord set fixture is required meeting BAP, Digit 13, "Power and Monitoring", must be M.
3. EQ light fixtures are only available as a one connector option.
4. All Style 1 corded fixtures will include a ground lug. All Style 6 or 3-pole corded fixtures will be provided with grounding screw(s).
5. SO cord set option is not compatible with shallow bases. If required please contact ADB Safegate.
6. Color used with L-852D(L) for medium intensity runway edge and threshold applications.
7. L-852J&K(L) unidirectional applications only.
8. Not ETL submitted or not applicable to FAA market.

6.2 LED Taxiway Centerline (ICAO)

Ordering Code

	Application	Standard(s)	Market Specific	Dimensions	Prism	Beam Orientation	Toe-in	Color - Side 1 (Left)	Color - Side 2 (Right)	Power and Monitoring	Connector and Cable ¹¹	Options	Version
RS	<input type="checkbox"/>	<input type="checkbox"/>	<input type="checkbox"/>	<input type="checkbox"/>	<input type="checkbox"/>	<input type="checkbox"/>	<input type="checkbox"/>	<input type="checkbox"/>	<input type="checkbox"/>	<input type="checkbox"/>	<input type="checkbox"/>	<input type="checkbox"/>	<input type="checkbox"/>

Application

TC = Taxiway Centerline Narrow¹

TK = Taxiway Centerline Curved²

TR = Enhanced Taxiway Centerline for Rapid Exit³

TW = Taxiway centerline Wide⁴⁵

Standard(s)

3 = ICAO⁶

Market Specific

0 = None

Dimensions

1 = 8 inch (203 mm) diameter, 2 bolt

2 = 12 inch (305 mm) diameter, 11.25 inch BC (285 mm)

Prism

S = Standard prism

R = Reinforced prism

Beam Orientation

1 = Unidirectional

2 = Bidirectional

Toe-in

N = None⁸

C = Curved^{7, 8}

Color - Side 1 (Left)

F = F-Green (ICAO, default green)

Y = Yellow

B = Blue

G = G-Green (MOS and ICAO special)

N = None⁹

Color - Side 2 (Right)

F = F-Green (ICAO, default green)

Y = Yellow

B = Blue

G = G-Green (MOS and ICAO special)

N = None

Power and Monitoring

S = 2.8 - 6.6 A, Non-Monitored — Power Only

M = 2.8 - 6.6 A, Fail-Open Monitoring

R = 2.8 - 6.6 A, EQ Integrated LINC 360¹⁰

Connector and Cable¹¹

1 = 1 x Style 6 2-Pole Plug, 2 Individual Wires

2 = 1 x Style 1 2-Pole Plug, Jacketed SO 2 Core Cable¹²

3 = 2 x Style 6 2-Pole Plug, 2 Individual Wires

4 = 2 x Style 1 2-Pole Plug, Jacketed SO 2 Core Cable¹²

5 = 1 x Flat 3-Pole Plug, 3 Individual Wires

6 = 2 x Flat 3-Pole Plug, 3 Individual Wires

Options

0 = None

1 = Arctic Kit

Version

1 = Version 1

Ordering Code Notes

1. Straight sections, Narrow Beam, < 350 m RVR. Used for turn pad centerline light.
2. Lead-on/exit, Curved Beam, < 350 m RVR. Used for turn pad light.
3. Taxiway centerline, Wide Beam, < 350 m RVR.
4. Taxiway centerline, straight sections, Wide Beam, < 350 m RVR.
5. TW application includes Intermediate Holding Position light which is Yellow/Blank with wide beam distribution.
6. Includes standards NATO, EASA, STAC, CAP 168, TP 312 and MOS 139.
7. TK application only.
8. Left and right side determined by viewing fixture from interior turn radius pavement edge. Side 1 is on your left, side 2 is on your right.
9. LE application only.
10. EQ light fixtures are only available as a one connector option.
11. All Style 1 corded fixtures will include a ground lug. All Style 6 or 3-pole corded fixtures will be provided with grounding screw(s).
12. SO cord set option is not compatible with shallow bases. If required please contact ADB Safegate.

6.3 LED Triple Line Taxiway Centerline Light

Ordering Code

	Application	Standard(s)	Market Specific	Dimensions	Prism	Beam Orientation	Toe-in	Color - Side 1 (Left)	Color - Side 2 (Left)	Power and Monitoring	Connector and Cable ⁶	Options	Version
RS	<input type="checkbox"/>	<input type="checkbox"/>	<input type="checkbox"/>	<input type="checkbox"/>	<input type="checkbox"/>	<input type="checkbox"/>	<input type="checkbox"/>	<input type="checkbox"/>	<input type="checkbox"/>	<input type="checkbox"/>	<input type="checkbox"/>	<input type="checkbox"/>	<input type="checkbox"/>

Application

3C = Curved Beam
 3N = Narrow Beam
 3W = Wide Beam

Standard(s)

4 = Other

Market Specific

0 = None

Dimensions

1 = 8 inch (203 mm) diameter, 2 bolt
 2 = 12 inch (305 mm) diameter, 11.25 inch BC (285 mm)

Prism

S = Standard prism
 R = Reinforced prism

Beam Orientation

1 = Unidirectional
 2 = Bidirectional

Toe-in

N = None²
 C = Curved^{1, 3}
 L = Left Side Toe-in (Unidirectional)^{1, 4}
 R = Right Side Toe-in (Unidirectional)¹⁴

Color - Side 1 (Left)

F = F-Green (ICAO, default green)
 B = Blue
 A = Amber
 N = None⁸

Color - Side 2 (Left)

F = F-Green (ICAO, default green)
 B = Blue
 A = Amber
 N = None

Power and Monitoring

S = 2.8 - 6.6 A, Non-Monitored — Power Only
 M = 2.8 - 6.6 A, Fail-Open Monitoring
 R = 2.8 - 6.6 A, EQ Integrated LINC 360⁵

Connector and Cable⁶

1 = 1 x Style 6 2-Pole Plug, 2 Individual Wires
 2 = 1 x Style 1 2-Pole Plug, Jacketed SO 2 Core Cable⁷
 3 = 2 x Style 6 2-Pole Plug, 2 Individual Wires
 4 = 2 x Style 1 2-Pole Plug, Jacketed SO 2 Core Cable⁷
 5 = 1 x Flat 3-Pole Plug, 3 Individual Wires
 6 = 2 x Flat 3-Pole Plug, 3 Individual Wires

Options

0 = None
 1 = Arctic Kit

Version

1 = Version 1

Ordering Code Notes

1. Left and right side determined by viewing fixture from interior turn radius pavement edge. Side 1 is on your left, side 2 is on your right.
2. 3N and 3W applications.
3. 3C bidirectional application.
4. 3C unidirectional application.
5. EQ light fixtures are only available as a one connector option.
6. All Style 1 corded fixtures will include a ground lug. All Style 6 or 3-pole corded fixtures will be provided with grounding screw(s).
7. SO cord set option is not compatible with shallow bases. If required please contact ADB Safegate.

6.4 LED L-852S(L) LED Stop Bar (FAA)

Ordering Code

	Application	Standard(s)	Market Specific	Dimensions	Prism	Beam Orientation	Toe-in	Color - Side 1 (Left)	Color - Side 2 (Right)	Power and Monitoring	Connector and Cable ³	Options	Version
RS	<input type="checkbox"/>	<input type="checkbox"/>	<input type="checkbox"/>	<input type="checkbox"/>	<input type="checkbox"/>	<input type="checkbox"/>	<input type="checkbox"/>	<input type="checkbox"/>	<input type="checkbox"/>	<input type="checkbox"/>	<input type="checkbox"/>	<input type="checkbox"/>	<input type="checkbox"/>

Application

SB = FAA Stop-Bar

Standard(s)

2 = FAA¹

Market Specific

0 = None

1 = Buy American Preference (BAP)²

Dimensions

1 = 8 inch (203 mm) diameter, 2 bolt

2 = 12 inch (305 mm) diameter, 11.25 inch BC (285 mm)

3 = 8 inch (203 mm) diameter, 4 bolt

Prism

S = Standard prism

R = Reinforced prism

Ordering Code Notes

1. Includes TP-312.
2. Required for FAA when funded by AIP.
3. All Style 1 corded fixtures will include a ground lug. All Style 6 or 3-pole corded fixtures will be provided with grounding screw(s).
4. SO cord set option is not compatible with shallow bases. If required please contact ADB Safegate.

6.5 LED Stopbar (ICAO)

Ordering Code

	Application	Standard(s)	Market Specific	Dimensions	Prism	Beam Orientation	Toe-in	Color - Side 1 (Left)	Color - Side 2 (Right)	Power and Monitoring	Connector and Cable ⁴	Options	Version
RS	<input type="checkbox"/>	<input type="checkbox"/>	<input type="checkbox"/>	<input type="checkbox"/>	<input type="checkbox"/>	<input type="checkbox"/>	<input type="checkbox"/>	<input type="checkbox"/>	<input type="checkbox"/>	<input type="checkbox"/>	<input type="checkbox"/>	<input type="checkbox"/>	<input type="checkbox"/>

Application

SB = ICAO Stop-Bar Wide Beam

Standard(s)

3 = ICAO¹

Market Specific

0 = None

Beam Orientation

1 = Unidirectional

Toe-in

N = None

Color - Side 1 (Left)

R = Red

Color - Side 2 (Right)

N = Not Applicable

Power and Monitoring

S = 2.8 - 6.6 A, Non-Monitored — Power Only

M = 2.8 - 6.6 A, Fail-Open Monitoring

R = 2.8 - 6.6 A, EQ Integrated LINC 360

Connector and Cable³

1 = 1 x Style 6 2-Pole Plug, 2 Individual Wires

2 = 1 x Style 1 2-Pole Plug, Jacketed SO 2 Core Cable⁴

Options

0 = None

1 = Arctic Kit

Version

1 = Version 1

Dimensions

1 = 8 inch (203 mm) diameter, 2 bolt

2 = 12 inch (305 mm) diameter, 11.25 inch BC (285 mm)

Prism

S = Standard prism

R = Reinforced prism

Beam Orientation

1 = Unidirectional

2 = Bidirectional

Toe-in

N = None

C = Curved

Color - Side 1 (Left)

R = Red

N = None²

Color - Side 2 (Right)

R = Red
N = None

Power and Monitoring

S = 2.8 - 6.6 A, Non-Monitored — Power Only
M = 2.8 - 6.6 A, Fail-Open Monitoring
R = 2.8 - 6.6 A, EQ Integrated LINC 360³

Connector and Cable⁴

1 = 1 x Style 6 2-Pole Plug, 2 Individual Wires
2 = 1 x Style 1 2-Pole Plug, Jacketed SO 2 Core Cable⁵
3 = 2 x Style 6 2-Pole Plug, 2 Individual Wires
4 = 2 x Style 1 2-Pole Plug, Jacketed SO 2 Core Cable⁵
5 = 1 x Flat 3-Pole Plug, 3 Individual Wires
6 = 2 x Flat 3-Pole Plug, 3 Individual Wires

Options

0 = None
1 = Arctic Kit⁶

Version

1 = Version 1

Ordering Code Notes

1. Includes standards NATO, EASA, STAC, and MOS 139.
2. Color used with L-852D(L) for medium intensity runway edge and threshold applications.
3. EQ light fixtures are only available as a one connector option.
4. All Style 1 corded fixtures will include a ground lug. All Style 6 or 3-pole corded fixtures will be provided with grounding screw(s).
5. SO cord set option is not compatible with shallow bases. If required please contact ADB Safegate.
6. Thermostatically controlled and compliant with FAA EB67D.

6.6 LED Runway Status L-850T(L), Runway Intersection (THL/RIL) and Runway Entry Light (REL)

Ordering Code

	Application	Standard(s)	Market Specific	Dimensions	Prism	Beam Orientation	Toe-in	Color - Side 1 (Left)	Color - Side 2 (Right)	Power and Monitoring	Connector and Cable ¹	Options	Version
RS	<input type="checkbox"/>	<input type="checkbox"/>	<input type="checkbox"/>	<input type="checkbox"/>	<input type="checkbox"/>	<input type="checkbox"/>	<input type="checkbox"/>	<input type="checkbox"/>	<input type="checkbox"/>	<input type="checkbox"/>	<input type="checkbox"/>	<input type="checkbox"/>	<input type="checkbox"/>

Application

RS = Runway Status; Takeoff/ Hold (THL); L-850T(L) (RIL); Runway Intersection

TS = Runway Status; Runway Entry (REL)¹

Standard(s)

2 = FAA

Market Specific

0 = None

1 = Buy American Preference (BAP)

Dimensions

1 = 8 inch (203 mm) diameter, 2 bolt³

2 = 12 inch (305 mm) diameter, 11.25 inch BC (285 mm)

3 = 8 inch (203 mm) diameter, 4 bolt³

Prism

S = Standard prism

R = Reinforced prism³

Beam Orientation

1 = Unidirectional

Toe-in

N = None

Color - Side 1 (Left)

R = Red

Color - Side 2 (Right)

N = Not Applicable

Power and Monitoring

R = 2.8 - 6.6 A, EQ Integrated LINC 360

Connector and Cable¹

1 = 1 x Style 6 2-Pole Plug, 2 Individual Wires

2 = 1 x Style 1 2-Pole Plug, Jacketed SO 2 Core Cable²

Options

0 = None

1 = Arctic Kit

Version

1 = Version 1

Ordering Code Notes

1. All Style 1 corded fixtures will include a ground lug. All Style 6 or 3-pole corded fixtures will be provided with grounding screw(s).
2. SO cord set option is not compatible with shallow bases. If required please contact ADB Safegate.
3. Not ETL submitted or not applicable to FAA market.

7.0 Spare Parts

Spare parts are available for inset light fixtures with and without the control and monitoring functionality. For more information, see <http://www.adbsafegate.com/> and the spare part lists, or contact ADB SAFEGATE for assistance.

7.1 Versions and Exploded View

Figure 28: Taxiway Insets, Cord Set Options

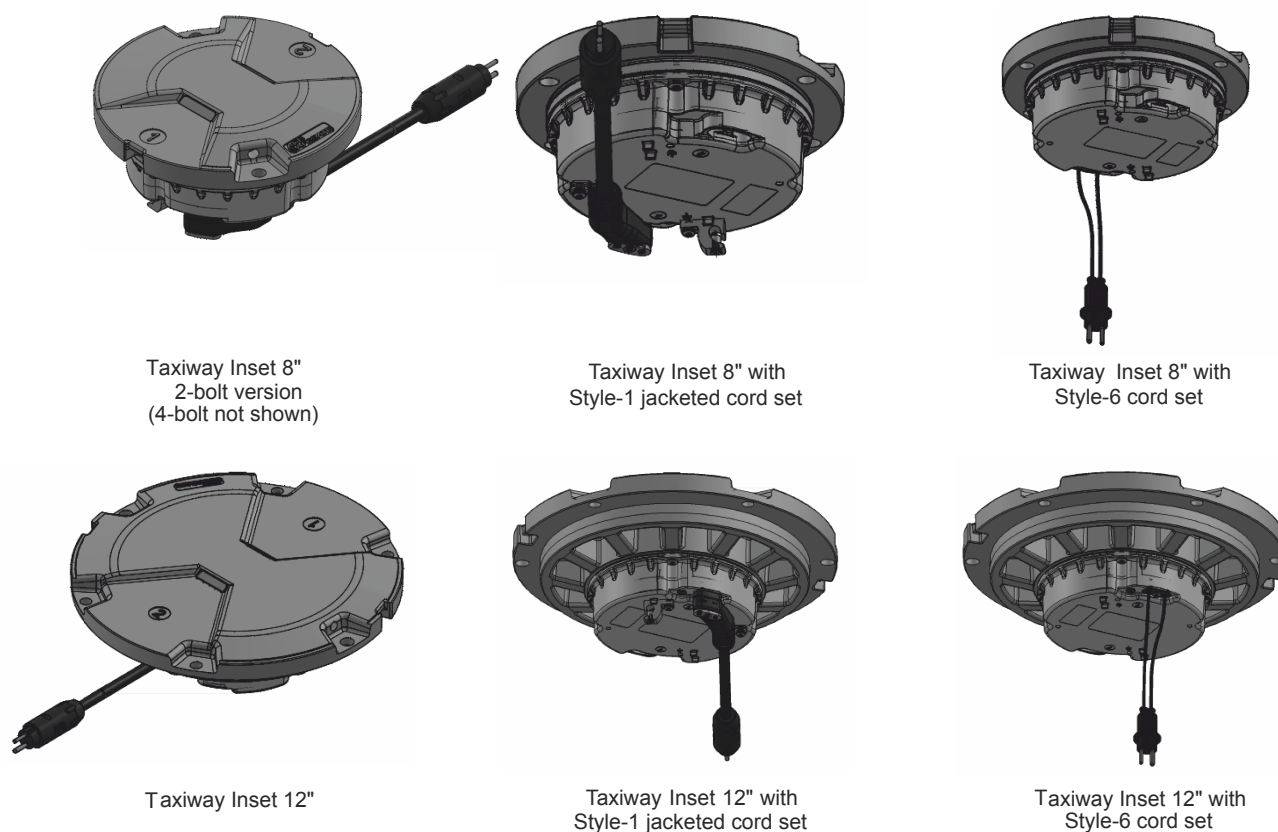

Partial Exploded View — Spare Part Assemblies

Figure 29: 8-Inch(Left) and 12-Inch(Right) Taxiway Inset Light

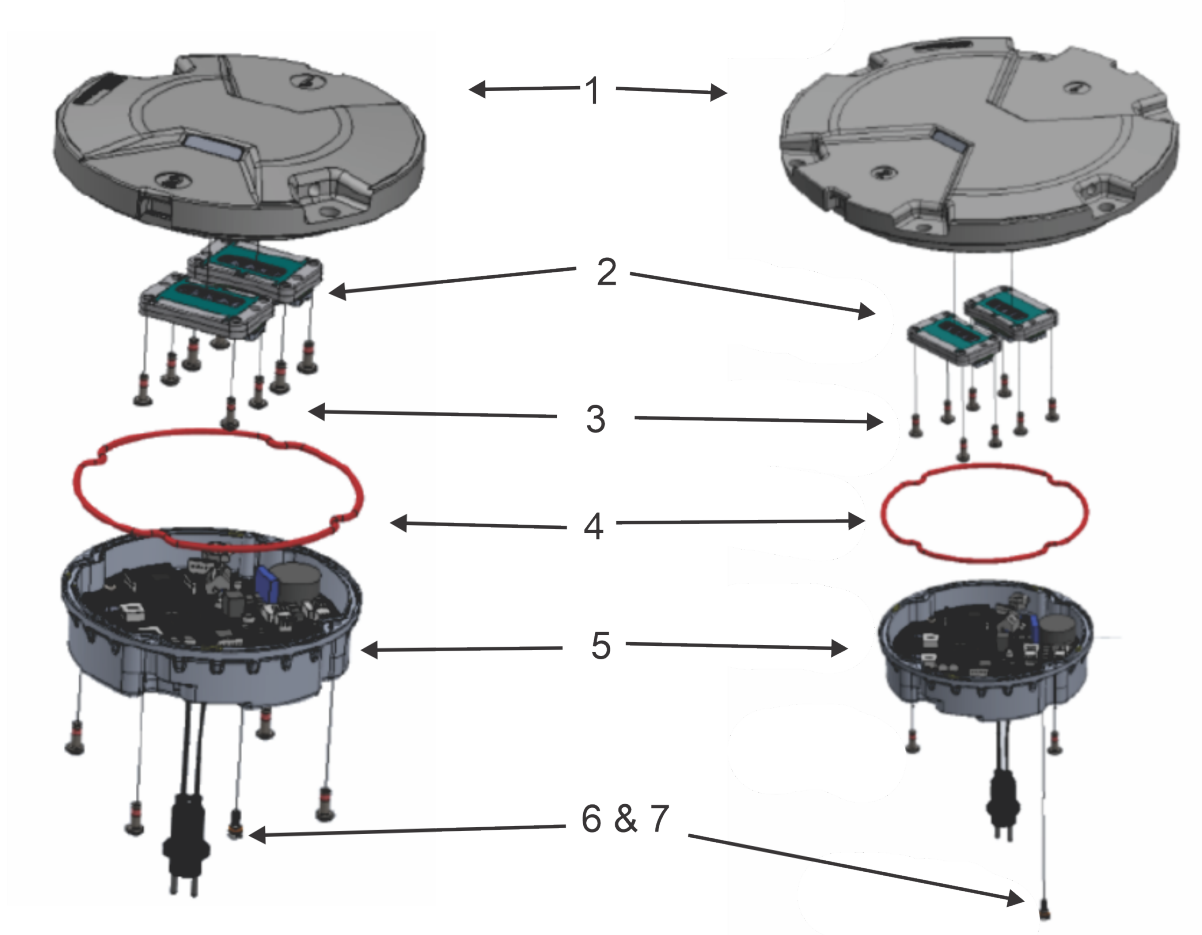

Call-out	Description	Assembly number prefix
1	Top Cover Assembly, 8-inch	SP.AS00135-XXX
2	Light Engine Assembly, 8-inch and 12-inch,	SP.AS00089-XXX
3	Mounting Screws Light engine assembly	SP.MFPM4PT-710-01
4 & 5	Bottom Pan Assembly, 8-inch	SP.AS00021-XXX
6	Mounting Screws, Bottom Pan	SP.MFPM5PT-714-01
7	Pressure Relief Screw with O-ring	SP.MF00090-000-01



Note

Full assembly numbers are listed in the spare part tables per application, starting from page 60 in the user manual.

Call-out	Description	Assembly number prefix
1	Top Cover Assembly, 12-inch	SP.AS00136-XXX
2	Light Engine Assembly, 8-inch and 12-inch,	SP.AS00089-XXX
2	Light Engine Assembly, 8-inch and 12-inch, with Arctic Kit	SP.AS00137-XXX
3	Mounting Screws, Bottom Pan and Light Engine Screws & Gasket	SP.MFPM5PT-714-01
4	Gasket, 8" Bottom Pan	SP.MS00005-000-01
5	Bottom Pan Assembly, 8-inch and 12-inch	SP.AS00021-XXX
6 & 7	Pressure Relief Screw with O-ring	SP.MF00090-000-01

7.2 Illustrations

Figure 30: Top Cover Assemblies, 8-inch/12-inch

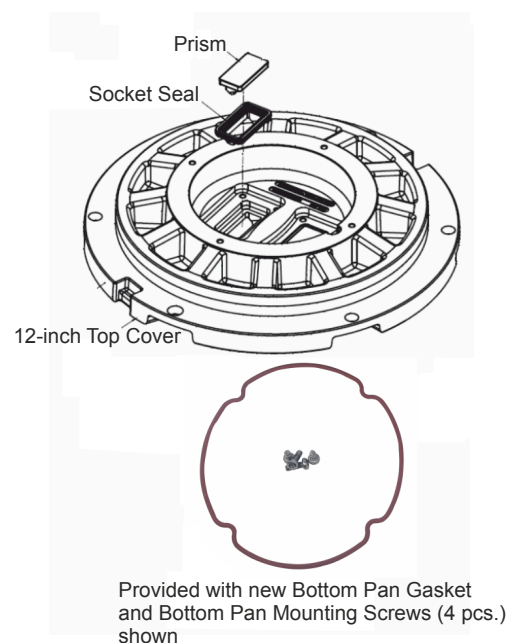
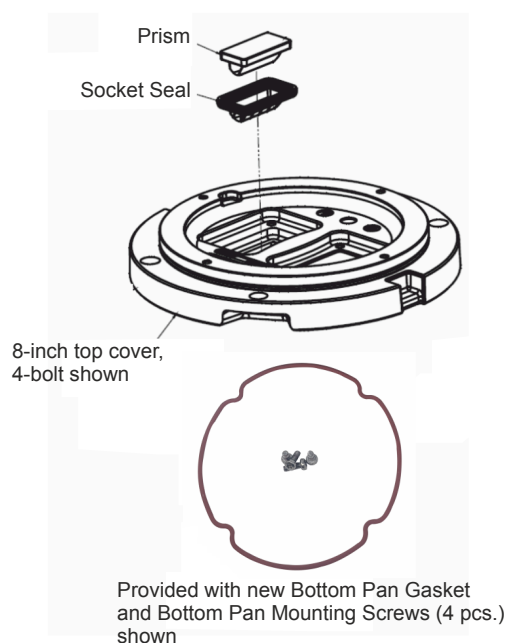
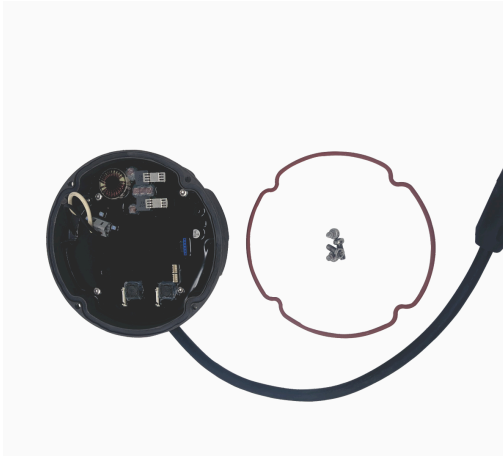

Figure 31: Bottom Pan Assembly



8 - inch Taxiway Bottom Pan assembly
compatible with both 8 - inch and
12 - inch top covers

Figure 32: Prism Spares



Taxiway replacement prism (package of 10)
available options :
Standard
Reinforced (Sapphire coated)

Figure 33: Ground lugs, package of 5



Figure 34: Cable Clamps, package of 5



Figure 35: Mounting screws, package of 100



Figure 36: Pressure release screws, package of 5



Note

Pressure release screw O-ring is to be replaced with new O-ring prior to re-installation of the pressure release screw.

7.3 Taxiway Centerline Light FAA



NOTICE

- Each Top Cover Assembly includes a Bottom Cover Gasket and a Bottom Cover Screws.
- BAP stands for "Buy American Preference".

A1 - Top Cover Assemblies, 12-inch	Quantity per		spare part code
	fitting	spare part	
unidirectional straight, standard prism	1	1	SP.AS00136-S1S
unidirectional straight, reinforced prism	1	1	SP.AS00136-S1R
unidirectional side 1 curved, standard prism	1	1	SP.AS00136-C1S
unidirectional side 1 curved, reinforced prism	1	1	SP.AS00136-C1R
unidirectional side 2 curved, standard prism	1	1	SP.AS00136-C2S
unidirectional side 2 curved, reinforced prism	1	1	SP.AS00136-C2R
bidirectional, straight, standard prism	1	1	SP.AS00136-SBS
bidirectional, straight, reinforced prism	1	1	SP.AS00136-SBR
bidirectional curved, standard prism	1	1	SP.AS00136-CBS
bidirectional curved, reinforced prism	1	1	SP.AS00136-CBR

A2 - Top Cover Assemblies, 8-inch	Quantity per		spare part code
	fitting	spare part	
unidirectional straight, standard prism	1	1	SP.AS00135-S1S
unidirectional straight, reinforced prism	1	1	SP.AS00135-S1R
unidirectional side 1 curved, standard prism	1	1	SP.AS00135-C1S
unidirectional side 1 curved, reinforced prism	1	1	SP.AS00135-C1R
unidirectional side 2 curved, standard prism	1	1	SP.AS00135-C3S
unidirectional side 2 curved, reinforced prism	1	1	SP.AS00135-C3R
bidirectional straight, standard prism	1	1	SP.AS00135-S5S
bidirectional straight, reinforced prism	1	1	SP.AS00135-S5R
bidirectional curved, standard prism	1	1	SP.AS00135-C5S
bidirectional curved, reinforced prism	1	1	SP.AS00135-C5R
4-bolt unidirectional straight, standard prism	1	1	SP.AS00135-S2S
4-bolt unidirectional straight, reinforced prism	1	1	SP.AS00135-S2R
4-bolt unidirectional side 1 curved, standard prism	1	1	SP.AS00135-C2S
4-bolt unidirectional side 1 curved, reinforced prism	1	1	SP.AS00135-C2R
4-bolt unidirectional side 2 curved, standard prism	1	1	SP.AS00135-C4S
4-bolt unidirectional side 2 curved, reinforced prism	1	1	SP.AS00135-C4R
4-bolt bidirectional straight, standard prism	1	1	SP.AS00135-S6S
4-bolt bidirectional straight, reinforced prism	1	1	SP.AS00135-S6R
4-bolt bidirectional curved, standard prism	1	1	SP.AS00135-C6S
4-bolt bidirectional curved, reinforced prism	1	1	SP.AS00135-C6R

B1 - Light Engine Assembly, 12-inch and 8-inch, without Arctic Kit Heater	Quantity per		spare part code
	fitting	spare part	
F-green for L-852A/B/J(L)	1 or 2	1	SP.AS00089-OFF
yellow for L-852A/B/J(L)	1 or 2	1	SP.AS00089-OYY
F-green for L-852D(L)	1 or 2	1	SP.AS00089-DFF
white for L-852D(L)	1 or 2	1	SP.AS00089-DWW
yellow for L-852D(L)	1 or 2	1	SP.AS00089-DYY
F-green curved for L-852K(L)	1 or 2	1	SP.AS00089-CFN
yellow curved for L-852K(L)	1 or 2	1	SP.AS00089-CYN
F-green narrow for L-852C(L)	1 or 2	1	SP.AS00089-NFN
yellow narrow for L-852C(L)	1 or 2	1	SP.AS00089-NYN

B2 - Light Engine Assembly, 12-inch and 8-inch, with Arctic Kit Heater	Quantity per		spare part code
	fitting	spare part	
F-green for L-852A/B/J(L), non-monitored or EQ (R)	1 or 2	1	SP.AS00137-OFF-E
yellow for L-852A/B/J(L), non-monitored or EQ (R)	1 or 2	1	SP.AS00137-OYY-E
F-green for L-852D(L), non-monitored or EQ (R)	1 or 2	1	SP.AS00137-DFF-E
white for L-852D(L), non-monitored or EQ (R)	1 or 2	1	SP.AS00137-DWW-E
yellow for L-852D(L), non-monitored or EQ (R)	1 or 2	1	SP.AS00137-DYY-E
F-green curved for L-852K(L), non-monitored or EQ (R)	1 or 2	1	SP.AS00137-CFN-E
yellow curved for L-852K(L), non-monitored or EQ (R)	1 or 2	1	SP.AS00137-CYN-E
F-green narrow for L-852C(L), non-monitored or EQ (R)	1 or 2	1	SP.AS00137-NFN-E
yellow narrow for L-852C(L), non-monitored or EQ (R)	1 or 2	1	SP.AS00137-NYN-E
F-green for L-852A/B/J(L), monitored (M)	1 or 2	1	SP.AS00137-OFF-F
yellow for L-852A/B/J(L), monitored (M)	1 or 2	1	SP.AS00137-OYY-F
F-green for L-852D(L), monitored (M)	1 or 2	1	SP.AS00137-DFF-F
white for L-852D(L), monitored (M)	1 or 2	1	SP.AS00137-DWW-F
yellow for L-852D(L), monitored (M)	1 or 2	1	SP.AS00137-DYY-F
F-green curved for L-852K(L), monitored (M)	1 or 2	1	SP.AS00137-CFN-F
yellow curved for L-852K(L), monitored (M)	1 or 2	1	SP.AS00137-CYN-F
F-green narrow for L-852C(L), monitored (M)	1 or 2	1	SP.AS00137-NFN-F
yellow narrow for L-852C(L), monitored (M)	1 or 2	1	SP.AS00137-NYN-F

C - Bottom Cover Assemblies, 12-inch and 8-inch	Quantity per		spare part code
	fitting	spare part	
non-monitored converter, style 6 cord set	1	1	SP.AS00021-L13
non-monitored converter, style 1 SJO jacketed cord set	1	1	SP.AS00021-L1J
non-monitored converter, 2-con style 6 cord sets	1	1	SP.AS00021-L23
non-monitored converter, 2-con style 1 SJO jacketed cord sets	1	1	SP.AS00021-L2J
monitored converter, style 6 cord set	1	1	SP.AS00021-M13
monitored converter, style 1 SJO jacketed cord set	1	1	SP.AS00021-M1J
monitored converter, 2-con style 6 cord sets	1	1	SP.AS00021-M23
monitored converter, 2-con style 1 SJO jacketed cord sets	1	1	SP.AS00021-M2J
EQ converter, style 6 cord set	1	1	SP.AS00021-R13
EQ converter, style 1 SJO jacketed cord set	1	1	SP.AS00021-R1J

C - Bottom Cover Assemblies, 12-inch and 8-inch	Quantity per		spare part code
	fitting	spare part	
Buy American Preference non-monitored converter, style 6 cord set	1	1	SP.AS00021-S13
Buy American Preference non-monitored converter, style 1 SJO jacketed cord set	1	1	SP.AS00021-S1J

Cord Sets	Quantity per		spare part code
	fitting	spare part	
Cord set, L-823 style 1	1 or 2	5	SP.73A0193/1
Cord set, L-823 style 6	1 or 2	5	SP.73A0136/18
Cable retaining clamp, for use with style 1 cord set	1 or 2	5	SP.MB00003-013-01
Ground lug kit	1	5	SP.72A0401

Prism Spares	Quantity per		spare part code
	fitting	spare part	
Prism kit, taxiway, standard	1 or 2	10	SP.4072.40.412
Prism kit, taxiway, reinforced	1 or 2	10	SP.4072.42.090
Prism gasket kit	1 or 2	10	SP.4072.40.421

Screws and Gaskets	Quantity per		spare part code
	fitting	spare part	
Pressure release screw with o-ring	1	5	SP.MF00090-000-01
Gasket, 8" bottom pan	1	10	SP.MS00005-000-01
Screws, 8" bottom pan	-	100	SP.MFPM5PT-714-01
Screws, light engine assembly mounting	-	100	SP.MFPM4PT-710-01

Wire harness	Quantity per		spare part code
	fitting	spare part	
Wire harness, power supply to light engine	1 or 2	10	SP.EW00070-150-01

Fuse	Quantity per		spare part code
	fitting	spare part	
Fuse resistors (only for fixtures with monitoring (M))	2 or 4	20	6132.00.250



Note

All screws for fastening are included.

Component availability or design may be subject to change due to unforeseen circumstances. This document is subject to change or new information from ADB SAFEGATE, as and when available or if required, with reservation for error or price changes.

For more information or assistance with ordering spare parts, contact ADB SAFEGATE, see www.adbsafegate.com.

7.4 Taxiway Centerline Light ICAO



NOTICE

- Each Top Cover Assembly includes a Bottom Cover Gasket and a Bottom Cover Screws.
- BAP stands for "Buy American Preference".

A1 - Top Cover Assemblies, 12-inch	Quantity per		spare part code
	fitting	spare part	
unidirectional straight, standard prism	1	1	SP.AS00136-S1S
unidirectional straight, reinforced prism	1	1	SP.AS00136-S1R
unidirectional side 1 curved, standard prism	1	1	SP.AS00136-C1S
unidirectional side 1 curved, reinforced prism	1	1	SP.AS00136-C1R
unidirectional side 2 curved, standard prism	1	1	SP.AS00136-C3S
unidirectional side 2 curved, reinforced prism	1	1	SP.AS00136-C3R
bidirectional straight, standard prism	1	1	SP.AS00136-S5S
bidirectional straight, reinforced prism	1	1	SP.AS00136-S5R
bidirectional curved, standard prism	1	1	SP.AS00136-C5S
bidirectional curved, reinforced prism	1	1	SP.AS00136-C5R

A2 - Top Cover Assemblies, 8-inch	Quantity per		spare part code
	fitting	spare part	
unidirectional straight, standard prism	1	1	SP.AS00135-S1S
unidirectional straight, reinforced prism	1	1	SP.AS00135-S1R
unidirectional side 1 curved, standard prism	1	1	SP.AS00135-C1S
unidirectional side 1 curved, reinforced prism	1	1	SP.AS00135-C1R
unidirectional side 2 curved, standard prism	1	1	SP.AS00135-C2S
unidirectional side 2 curved, reinforced prism	1	1	SP.AS00135-C2R
bidirectional, straight, standard prism	1	1	SP.AS00135-SBS
bidirectional, straight, reinforced prism	1	1	SP.AS00135-SBR
bidirectional curved, standard prism	1	1	SP.AS00135-CBS
bidirectional curved, reinforced prism	1	1	SP.AS00135-CBR

B1 - Light Engine Assembly, 12-inch and 8-inch, without Arctic Kit Heater	Quantity per		spare part code
	fitting	spare part	
F-green wide	1 or 2	1	SP.AS00089-WFN-TW
F-green enhanced taxiway centerline for rapid exit	1 or 2	1	SP.AS00089-WFF-TR
yellow wide	1 or 2	1	SP.AS00089-WYN-TW
yellow enhanced taxiway centerline for rapid exit	1 or 2	1	SP.AS00089-WYY-TR
F-green curved	1 or 2	1	SP.AS00089-CFN
yellow curved	1 or 2	1	SP.AS00089-CYN
F-green narrow	1 or 2	1	SP.AS00089-NFN
yellow narrow	1 or 2	1	SP.AS00089-NYN
G-green wide	1 or 2	1	SP.AS00089-WGN-TW
G-green enhanced taxiway centerline for rapid exit	1 or 2	1	SP.AS00089-WGG-TR

B1 - Light Engine Assembly, 12-inch and 8-inch, without Arctic Kit Heater	Quantity per		spare part code
	fitting	spare part	
G-green curved	1 or 2	1	SP.AS00089-CGN
G-green narrow	1 or 2	1	SP.AS00089-NGN
B2 - Light Engine Assembly, 12-inch and 8-inch, with Arctic Kit Heater	Quantity per		spare part code
	fitting	spare part	
F-green wide, EQ (R)	1 or 2	1	SP.AS00137-WFN-TWE
F-green enhanced taxiway centreline for rapid exit, EQ (R)	1 or 2	1	SP.AS00137-WFF-TRE
yellow wide, EQ (R)	1 or 2	1	SP.AS00137-WYN-TWE
yellow enhanced taxiway centreline for rapid exit, EQ (R)	1 or 2	1	SP.AS00137-WYY-TRE
F-green curved, EQ (R)	1 or 2	1	SP.AS00137-CFN-E
yellow curved, EQ (R)	1 or 2	1	SP.AS00137-CYN-E
F-green narrow, EQ (R)	1 or 2	1	SP.AS00137-NFN-E
yellow narrow, EQ (R)	1 or 2	1	SP.AS00137-NYN-E
F-green wide, non monitored (S) or monitored (M)	1 or 2	1	SP.AS00137-WFN-TWF
F-green enhanced taxiway centreline for rapid exit, non monitored (S) or monitored (M)	1 or 2	1	SP.AS00137-WFF-TRF
yellow wide, non monitored (S) or monitored (M)	1 or 2	1	SP.AS00137-WYN-TWF
yellow enhanced taxiway centerline for rapid exit, non monitored (S) or monitored (M)	1 or 2	1	SP.AS00137-WYY-TRF
F-green curved, non monitored (S) or monitored (M)	1 or 2	1	SP.AS00137-CFN-F
yellow curved, non monitored (S) or monitored (M)	1 or 2	1	SP.AS00137-CYN-F
F-green narrow, non monitored (S) or monitored (M)	1 or 2	1	SP.AS00137-NFN-F
yellow narrow, non monitored (S) or monitored (M)	1 or 2	1	SP.AS00137-NYN-F
G-green wide, EQ (R)	1 or 2	1	SP.AS00137-WGN-TWE
G-green enhanced taxiway centerline for rapid exit, EQ (R)	1 or 2	1	SP.AS00137-WGG-TRE
G-green curved, EQ (R)	1 or 2	1	SP.AS00137-CGN-E
G-green narrow, EQ (R)	1 or 2	1	SP.AS00137-NGN-E
G-green wide, non monitored (S) or monitored (M)	1 or 2	1	SP.AS00137-WGN-TWF
G-green enhanced taxiway centerline for rapid exit, non monitored (S) or monitored (M)	1 or 2	1	SP.AS00137-WGG-TRF
G-green curved, non monitored (S) or monitored (M)	1 or 2	1	SP.AS00137-CGN-F
G-green narrow, non monitored (S) or monitored (M)	1 or 2	1	SP.AS00137-NGN-F
C - Bottom Cover Assemblies, 12-inch and 8-inch	Quantity per		spare part code
	fitting	spare part	
non-monitored converter, style 6 cord set	1	1	SP.AS00021-L13
non-monitored converter, 3-pole cord set	1	1	SP.AS00021-L1F
non-monitored converter, style 1 SJO jacketed cord set	1	1	SP.AS00021-L1J
non-monitored converter, 2-con style 6 cord sets	1	1	SP.AS00021-L23
non-monitored converter, 2-con 3-pole cord sets	1	1	SP.AS00021-L2F
non-monitored converter, 2-con style 1 SJO jacketed cord sets	1	1	SP.AS00021-L2J
monitored converter, style 6 cord set	1	1	SP.AS00021-M13
monitored converter, 3-pole cord set	1	1	SP.AS00021-M1F
monitored converter, style 1 SJO jacketed cord set	1	1	SP.AS00021-M1J

C - Bottom Cover Assemblies, 12-inch and 8-inch	Quantity per		spare part code
	fitting	spare part	
monitored converter, 2-con style 6 cord sets	1	1	SP.AS00021-M23
monitored converter, 2-con 3-pole cord sets	1	1	SP.AS00021-M2F
monitored converter, 2-con style 1 SJO jacketed cord sets	1	1	SP.AS00021-M2J
EQ converter, style 6 cord set	1	1	SP.AS00021-R13
EQ converter, 3-pole cord set	1	1	SP.AS00021-R1F
EQ converter, style 1 SJO jacketed cord set	1	1	SP.AS00021-R1J

Cord Sets	Quantity per		spare part code
	fitting	spare part	
Cord set, L-823 style 1	1 or 2	5	SP.73A0193/1
Cord set, L-823 style 6	1 or 2	5	SP.73A0136/18
Cord set, 3-pole	1 or 2	5	SP.SGEFR500160
Cable retaining clamp, for use with style 1 cord set	1 or 2	5	SP.MB00003-013-01
Ground lug kit	1	5	SP.72A0401

Prism Spares	Quantity per		spare part code
	fitting	spare part	
Prism kit, taxiway, standard	1 or 2	10	SP.4072.40.412
Prism kit, taxiway reinforced	1 or 2	10	SP.4072.42.090
Prism gasket kit	1 or 2	10	SP.4072.40.421

Screws and Gaskets	Quantity per		spare part code
	fitting	spare part	
Pressure release screw with o-ring	1	5	SP.MF00090-000-01
Gasket, 8" Bottom pan	1	10	SP.MS00005-000-01
Screws, 8" Bottom pan	-	100	SP.MFPM5PT-714-01
Screws, light engine assembly mounting	-	100	SP.MFPM4PT-710-01

Wire harness	Quantity per		spare part code
	fitting	spare part	
Wire harness, power supply to light engine	1 or 2	10	SP.EW00070-150-01

Fuse	Quantity per		spare part code
	fitting	spare part	
Fuse Resistors (only for fixtures with monitoring (M))	2 or 4	20	6132.00.250



Note

All screws for fastening are included.

Component availability or design may be subject to change due to unforeseen circumstances. This document is subject to change or new information from ADB SAFEGATE, as and when available or if required, with reservation for error or price changes.

For more information or assistance with ordering spare parts, contact ADB SAFEGATE, see www.adbsafegate.com.

7.5 Triple Line Taxiway Centerline Light

A1 - Top Cover Assemblies, 12-inch	Quantity per		spare part code
	fitting	spare part	
unidirectional straight, standard prism	1	1	SP.AS00136-S1S
unidirectional straight, reinforced prism	1	1	SP.AS00136-S1R
unidirectional side 1 curved, standard prism	1	1	SP.AS00136-C1S
unidirectional side 1 curved, reinforced prism	1	1	SP.AS00136-C1R
unidirectional side 2 curved, standard prism	1	1	SP.AS00136-C2S
unidirectional side 2 curved, reinforced prism	1	1	SP.AS00136-C2R
bidirectional, straight, standard prism	1	1	SP.AS00136-SBS
bidirectional, straight, reinforced prism	1	1	SP.AS00136-SBR
bidirectional curved, standard prism	1	1	SP.AS00136-CBS
bidirectional curved, reinforced prism	1	1	SP.AS00136-CBR

A2 - Top Cover Assemblies, 8-inch	Quantity per		spare part code
	fitting	spare part	
unidirectional straight, standard prism	1	1	SP.AS00135-S1S
unidirectional straight, reinforced prism	1	1	SP.AS00135-S1R
unidirectional side 1 curved, standard prism	1	1	SP.AS00135-C1S
unidirectional side 1 curved, reinforced prism	1	1	SP.AS00135-C1R
unidirectional side 2 curved, standard prism	1	1	SP.AS00135-C3S
unidirectional side 2 curved, reinforced prism	1	1	SP.AS00135-C3R
bidirectional straight, standard prism	1	1	SP.AS00135-S5S
bidirectional straight, reinforced prism	1	1	SP.AS00135-S5R
bidirectional curved, standard prism	1	1	SP.AS00135-C5S
bidirectional curved, reinforced prism	1	1	SP.AS00135-C5R

B1 & B2 - Light Engine Assembly, 12-inch and 8-inch	Quantity per		spare part code
	fitting	spare part	
To be completed			

C - Bottom Cover Assemblies, 12-inch and 8-inch	Quantity per		spare part code
	fitting	spare part	
To be completed			

Cord Sets	Quantity per		spare part code
	fitting	spare part	
non-monitored converter, style 6 cord set	1	1	SP.AS00021-L13
non-monitored converter, 3-pole cord set	1	1	SP.AS00021-L1F
non-monitored converter, style 1 SJO jacketed cord set	1	1	SP.AS00021-L1J
non-monitored converter, 2-con style 6 cord sets	1	1	SP.AS00021-L23
non-monitored converter, 2-con 3-pole cord sets	1	1	SP.AS00021-L2F
non-monitored converter, 2-con style 1 SJO jacketed cord sets	1	1	SP.AS00021-L2J
monitored converter, style 6 cord set	1	1	SP.AS00021-M13
monitored converter, 3-pole cord set	1	1	SP.AS00021-M1F

Cord Sets	Quantity per		spare part code
	fitting	spare part	
monitored converter, style 1 SJO jacketed cord set	1	1	SP.AS00021-M1J
monitored converter, 2-con style 6 cord sets	1	1	SP.AS00021-M23
monitored converter, 2-con 3-pole cord sets	1	1	SP.AS00021-M2F
monitored converter, 2-con style 1 SJO jacketed cord sets	1	1	SP.AS00021-M2J
EQ converter, style 6 cord set	1	1	SP.AS00021-R13
EQ converter, 3-pole cord set	1	1	SP.AS00021-R1F
EQ converter, style 1 SJO jacketed cord set	1	1	SP.AS00021-R1J

Cord Sets	Quantity per		spare part code
	fitting	spare part	
Cord set, L-823 style 1	1 or 2	5	SP.73A0193/1
Cord set, L-823 style 6	1 or 2	5	SP.73A0136/18
Cord set, 3-pole	1 or 2	5	SP.SGFR500160
Cable retaining clamp, for use with style 1 cord set	1 or 2	5	SP.MB00003-013-01
Ground lug kit	1	5	SP.72A0401

Prism Spares	Quantity per		spare part code
	fitting	spare part	
Prism kit, taxiway, standard	1 or 2	10	SP.4072.40.412
Prism kit, taxiway reinforced	1 or 2	10	SP.4072.42.090
Prism gasket kit	1 or 2	10	SP.4072.40.421

Screws and Gaskets	Quantity per		spare part code
	fitting	spare part	
Pressure release screw with o-ring	1	5	SP.MF00090-000-01
Gasket, 8" Bottom pan	1	10	SP.MS00005-000-01
Screws, 8" Bottom pan	-	100	SP.MFPM5PT-714-01
Screws, light engine assembly mounting	-	100	SP.MFPM4PT-710-01

Wire harness	Quantity per		spare part code
	fitting	spare part	
Wire harness, power supply to light engine	1 or 2	10	SP.EW00070-150-01

Fuse	Quantity per		spare part code
	fitting	spare part	
Fuse Resistors (only for fixtures with monitoring (M))	2 or 4	20	6132.00.250



Note

All screws for fastening are included.

Component availability or design may be subject to change due to unforeseen circumstances. This document is subject to change or new information from ADB SAFEGATE, as and when available or if required, with reservation for error or price changes.

For more information or assistance with ordering spare parts, contact ADB SAFEGATE, see www.adbsafegate.com.

7.6 Stop Bar Light FAA



NOTICE

- Each Top Cover Assembly includes a Bottom Cover Gasket and a Bottom Cover Screws.
- BAP stands for "Buy American Preference".

A1 - Top Cover Assemblies, 12-inch	Quantity per		spare part code
	fitting	spare part	
unidirectional straight, standard prism	1	1	SP.AS00136-S1S
unidirectional straight, reinforced prism	1	1	SP.AS00136-S1R
A2 - Top Cover Assemblies, 8-inch	Quantity per		spare part code
	fitting	spare part	
unidirectional straight, standard prism	1	1	SP.AS00135-S1S
unidirectional straight, reinforced prism	1	1	SP.AS00135-S1R
4-bolt unidirectional straight, standard prism	1	1	SP.AS00135-S2S
4-bolt unidirectional straight, reinforced prism	1	1	SP.AS00135-S2R
B1 & B2 - Light Engine Assembly, 12-inch and 8-inch	Quantity per		spare part code
	fitting	spare part	
red for L-852S(L) FAA stop bar and REL without heater	1	1	SP.AS00089-SRR
red for L-852S(L) FAA stop bar and REL monitored (M) with heater	1	1	SP.AS00137-SRR-F
red for L-852S(L) FAA stop bar and REL non-monitored or EQ (R) with heater	1	1	SP.AS00137-SRR-E
C - Bottom Cover Assemblies, 12-inch and 8-inch	Quantity per		spare part code
	fitting	spare part	
non-monitored converter, style 6 cord set	1	1	SP.AS00021-L13
non-monitored converter, style 1 SJO jacketed cord set	1	1	SP.AS00021-L1J
monitored converter, style 6 cord set	1	1	SP.AS00021-M13
monitored converter, style 1 SJO jacketed cord set	1	1	SP.AS00021-M1J
EQ converter, style 6 cord set	1	1	SP.AS00021-R13
EQ converter, style 1 SJO jacketed cord set	1	1	SP.AS00021-R1J
Buy American Preference non-monitored converter, style 6 cord set	1	1	SP.AS00021-S13
Buy American Preference non-monitored converter, style 1 SJO jacketed cord set	1	1	SP.AS00021-S1J
Cord Sets	Quantity per		spare part code
	fitting	spare part	
Cord set, L-823 style 1	1	5	SP.73A0193/1
Cord set, L-823 style 6	1	5	SP.73A0136/18
Cable retaining clamp, for use with style 1 cord set	1	5	SP.MB00003-013-01
Ground lug kit	1	5	SP.72A0401

Prism Spares	Quantity per		spare part code
	fitting	spare part	
Prism kit, taxiway, standard	1	10	SP.4072.40.412
Prism kit, taxiway reinforced	1	10	SP.4072.42.090
Prism gasket kit	1	10	SP.4072.40.421

Screws and Gaskets, 8-inch	Quantity per		spare part code
	fitting	spare part	
Pressure release screw with o-ring	1	5	SP.MF00090-000-01
Gasket, 8" Bottom pan	1	10	SP.MS00005-000-01
Screws, 8" Bottom pan	-	100	SP.MFPM5PT-714-01
Screws, light engine assembly mounting	-	100	SP.MFPM4PT-710-01

Wire Harness, 12-inch and 8-inch	Quantity per		spare part code
	fitting	spare part	
Wire harness, power supply to light engine	1	10	SP.EW00070-150-01

Fuse	Quantity per		spare part code
	fitting	spare part	
Fuse resistors (only for fixtures with monitoring (M))	2	20	6132.00.250



Note

All screws for fastening are included.

Component availability or design may be subject to change due to unforeseen circumstances. This document is subject to change or new information from ADB SAFEGATE, as and when available or if required, with reservation for error or price changes.

For more information or assistance with ordering spare parts, contact ADB SAFEGATE, see www.adbsafegate.com.

7.7 Stop Bar Light ICAO



NOTICE

- Each Top Cover Assembly includes a Bottom Cover Gasket and a Bottom Cover Screws.
- BAP stands for "Buy American Preference".

A1 - Top Cover Assemblies, 12-inch	Quantity per		spare part code
	fitting	spare part	
unidirectional straight, standard prism	1	1	SP.AS00136-S1S
unidirectional straight, reinforced prism	1	1	SP.AS00136-S1R
unidirectional side 1 curved, standard prism	1	1	SP.AS00136-C1S
unidirectional side 1 curved, reinforced prism	1	1	SP.AS00136-C1R
unidirectional side 2 curved, standard prism	1	1	SP.AS00136-C2S
unidirectional side 2 curved, reinforced prism	1	1	SP.AS00136-C2R
bidirectional, straight, standard prism	1	1	SP.AS00136-SBS
bidirectional, straight, reinforced prism	1	1	SP.AS00136-SBR
bidirectional curved, standard prism	1	1	SP.AS00136-CBS
bidirectional curved, reinforced prism	1	1	SP.AS00136-CBR

A2 - Top Cover Assemblies, 8-inch	Quantity per		spare part code
	fitting	spare part	
unidirectional straight, standard prism	1	1	SP.AS00135-S1S
unidirectional straight, reinforced prism	1	1	SP.AS00135-S1R
unidirectional side 1 curved, standard prism	1	1	SP.AS00135-C1S
unidirectional side 1 curved, reinforced prism	1	1	SP.AS00135-C1R
unidirectional side 2 curved, standard prism	1	1	SP.AS00135-C3S
unidirectional side 2 curved, reinforced prism	1	1	SP.AS00135-C3R
bidirectional straight, standard prism	1	1	SP.AS00135-S5S
bidirectional straight, reinforced prism	1	1	SP.AS00135-S5R
bidirectional curved, standard prism	1	1	SP.AS00135-C5S
bidirectional curved, reinforced prism	1	1	SP.AS00135-C5R

B1 & B2 - Light Engine Assembly, 12-inch and 8-inch	Quantity per		spare part code
	fitting	spare part	
red wide without heater	1 or 2	1	SP.AS00089-WRR-SB
red curved without heater	1 or 2	1	SP.AS00089-CRR-SB
red wide EQ (R) with heater	1 or 2	1	SP.AS00137-WRR-SBE
red curved EQ (R) with heater	1 or 2	1	SP.AS00137-CRR-SBE
red wide non-monitored (S) or monitored (M) with heater	1 or 2	1	SP.AS00137-WRR-SBF
red curved non-monitored (S) or monitored (M) with heater	1 or 2	1	SP.AS00137-CRR-SBF

C - Bottom Cover Assemblies, 12-inch and 8-inch	Quantity per		spare part code
	fitting	spare part	
non-monitored converter, style 6 cord set	1	1	SP.AS00021-L13
non-monitored converter, 3-pole cord set	1	1	SP.AS00021-L1F

C - Bottom Cover Assemblies, 12-inch and 8-inch	Quantity per		spare part code
	fitting	spare part	
non-monitored converter, style 1 SJO jacketed cord set	1	1	SP.AS00021-L1J
non-monitored converter, 2-con style 6 cord sets	1	1	SP.AS00021-L23
non-monitored converter, 2-con 3-pole cord sets	1	1	SP.AS00021-L2F
non-monitored converter, 2-con style 1 SJO jacketed cord sets	1	1	SP.AS00021-L2J
monitored converter, style 6 cord set	1	1	SP.AS00021-M13
monitored converter, 3-pole cord set	1	1	SP.AS00021-M1F
monitored converter, style 1 SJO jacketed cord set	1	1	SP.AS00021-M1J
monitored converter, 2-con style 6 cord sets	1	1	SP.AS00021-M23
monitored converter, 2-con 3-pole cord sets	1	1	SP.AS00021-M2F
monitored converter, 2-con style 1 SJO jacketed cord sets	1	1	SP.AS00021-M2J
EQ converter, style 6 cord set	1	1	SP.AS00021-R13
EQ converter, 3-pole cord set	1	1	SP.AS00021-R1F
EQ converter, style 1 SJO jacketed cord set	1	1	SP.AS00021-R1J
Cord Sets	Quantity per		spare part code
	fitting	spare part	
Cord set, L-823 style 1	1 or 2	5	SP.73A0193/1
Cord set, L-823 style 6	1 or 2	5	SP.73A0136/18
Cord set, 3-pole	1 or 2	5	SP.SGEFR500160
Cable retaining clamp, for use with style 1 cord set	1 or 2	5	SP.MB00003-013-01
Ground lug kit	1	5	SP.72A0401
Prism Spares	Quantity per		spare part code
	fitting	spare part	
Prism kit, taxiway, standard	1 or 2	10	SP.4072.40.412
Prism kit, taxiway, reinforced	1 or 2	10	SP.4072.42.090
Prism gasket kit	1 or 2	10	SP.4072.40.421
Screws and Gaskets	Quantity per		spare part code
	fitting	spare part	
Pressure release screw with o-ring	1	5	SP.MF00090-000-01
Gasket, 8" Bottom pan	1	10	SP.MS00005-000-01
Screws, 8" Bottom pan	-	100	SP.MFPM5PT-714-01
Screws, light engine assembly mounting	-	100	SP.MFPM4PT-710-01
Wire harness	Quantity per		spare part code
	fitting	spare part	
Wire harness, power supply to light engine	1 or 2	10	SP.EW00070-150-01
Fuse	Quantity per		spare part code
	fitting	spare part	
Fuse resistors (only for fixtures with monitoring (M))	2 or 4	20	6132.00.250



Note

All screws for fastening are included.

Component availability or design may be subject to change due to unforeseen circumstances. This document is subject to change or new information from ADB SAFEGATE, as and when available or if required, with reservation for error or price changes.

For more information or assistance with ordering spare parts, contact ADB SAFEGATE, see www.adbsafegate.com.

7.8 RWSL Runway Entry Light (REL)



Note

- Each top cover assembly includes a gasket and screws for bottom pan.
- BAP stands for "Buy American Preference".



NOTICE

- Each Top Cover Assembly includes a Bottom Cover Gasket and a Bottom Cover Screws.
- BAP stands for "Buy American Preference".

A1 - Top Cover Assemblies, 12-inch	Quantity per		spare part code
	fitting	spare part	
unidirectional straight, standard prism	1	1	SP.AS00136-S1S
unidirectional straight, reinforced prism	1	1	SP.AS00136-S1R
A2 - Top Cover Assemblies, 8-inch	Quantity per		spare part code
	fitting	spare part	
unidirectional straight, standard prism	1	1	SP.AS00135-S1S
unidirectional straight, reinforced prism	1	1	SP.AS00135-S1R
4-bolt unidirectional straight, standard prism	1	1	SP.AS00135-S2S
4-bolt unidirectional straight, reinforced prism	1	1	SP.AS00135-S2R
B1 & B2 - Light Engine Assembly, 12-inch and 8-inch	Quantity per		spare part code
	fitting	spare part	
red wide EQ (R) without heater	1	1	SP.AS00089-WRR-SB
red curved EQ (R) without heater	1	1	SP.AS00089-CRR-SB
red wide EQ (R) with heater	1	1	SP.AS00137-WRR-SBE
red curved EQ (R) with heater	1	1	SP.AS00137-CRR-SBE
red for L-852S(L) FAA stop bar and REL (EQ) no heater	1	1	SP.AS00089-SRR
red for L-852S(L) FAA stop bar and REL EQ (R) with heater	1	1	SP.AS00137-SRR-E
C - Bottom Cover Assemblies, 12-inch and 8-inch	Quantity per		spare part code
	fitting	spare part	
EQ converter, style 6 cord set	1	1	SP.AS00021-R13
EQ converter, style 1 SJO jacketed cord set	1	1	SP.AS00021-R1R
Cord Sets	Quantity per		spare part code
	fitting	spare part	
Cord set, L-823 style 1	1	5	SP.73A0193/1
Cord set, L-823 style 6	1	5	SP.73A0136/18
Cable retaining clamp, for use with style 1 cord set	1	5	SP.MB00003-013-01
Prism Spares	Quantity per		spare part code
	fitting	spare part	
Prism kit, taxiway, standard	1	10	SP.4072.40.412
Prism kit, taxiway reinforced	1	10	SP.4072.42.090
Prism gasket kit	1	10	SP.4072.40.421

Screws and Gaskets	Quantity per		spare part code
	fitting	spare part	
Pressure release screw with o-ring	1	5	SP.MF00090-000-01
Gasket, 8" Bottom pan	1	10	SP.MS00005-000-01
Screws, 8" Bottom pan	-	100	SP.MFPM5PT-714-01
Screws, light engine assembly mounting	-	100	SP.MFPM4PT-710-01

Wire harness	Quantity per		spare part code
	fitting	spare part	
Wire harness, power supply to light engine	1	10	SP.EW00070-150-01

Fuse	Quantity per		spare part code
	fitting	spare part	
Fuse resistors (only for fixtures with monitoring (M))	2 or 4	20	6132.00.250



Note

All screws for fastening are included.

Component availability or design may be subject to change due to unforeseen circumstances. This document is subject to change or new information from ADB SAFEGATE, as and when available or if required, with reservation for error or price changes.

For more information or assistance with ordering spare parts, contact ADB SAFEGATE, see www.adbsafegate.com.

8.0 POWER TABLES

LED ICAO Stop Bar

8- and 12-inch light fixtures without Arctic Kit (heater)

Fixture type - 1 cord set ¹	Fixture load	Isolation transformer		CCR load
		Wattage	Load	
Stop Bar, unidirectional	17.5 VA	25 W	9.8 VA	27.3 VA
Stop Bar, bidirectional	24 VA	25 W	9.8 VA	33.8 VA

8- and 12-inch light fixtures with Arctic Kit (heater)

Fixture type - 1 cord set ¹	Fixture load	Isolation transformer		CCR load
		Wattage	Load	
Stop Bar, unidirectional	49.5 VA	50 W	14 VA	63.5 VA
Stop Bar, bidirectional, straight	40 VA	50 W	14 VA	54 VA
Stop Bar, bidirectional, curved	37.8 VA	50 W	14 VA	51.8 VA

¹Values provided are for the "S" option non-monitored power only.

LED FAA L-852S(L) Stop Bar

8-inch and 12-inch light fixtures without Arctic Kit (heater)

Fixture type - 1 cord set ¹	Fixture load	Isolation transformer		CCR load
		Wattage	Load	
Stop bar, L-852S(L), unidirectional, red	17.5 VA	25 W	9.8 VA	27.3 VA

8-inch and 12-inch light fixtures with Arctic Kit (heater)

Fixture type - 1 cord set ¹	Fixture load	Isolation transformer		CCR load
		Wattage	Load	
Stop bar, L-852S(L), unidirectional	49.5 VA	45 W	14 VA	63.5 VA

¹Values provided are for the "S" option non-monitored power only.



Note

- EQ fixtures:
 - The isolation transformer must have an additional 8 VA available above the fixture load for communication bandwidth. Size transformer to next size up to assure additional 8 VA coverage
 - Legacy BRITE II or AGLAS 2 systems — Order "M" power supply
- Fail-open fixtures:
 - The maximum rating for the isolation transformer is 150 W
- Additional voltage loss not included in the above table which must be factored into the circuit load calculation:
 - Primary cables will result in a higher CCR load
 - Longer secondary cables may result in a larger size isolation transformer requirement
- Efficiency of the isolation transformer depends on the manufacturer of the transformer

LED ICAO Taxiway Centerline

TC-TK--TR-TW

8-inch and 12-inch light fixtures without Arctic Kit (heater)

Fixture type - 1 cord set ¹	Fixture load	Isolation transformer		CCR load
		Wattage	Load	
Taxiway Centerline Wide, bidirectional	13.5 VA	15 W	7.6 VA	21.1 VA
Taxiway Centerline Curved, bidirectional	12.4 VA	15 W	7.6 VA	20 VA
Taxiway Centerline Narrow, unidirectional	7.8 VA	15 W	10.1 VA	18 VA

8-inch and 12-inch light fixtures with Arctic Kit (heater)

Fixture type - 2 cord sets ¹	Fixture load		Isolation transformer				CCR load	
	Side 1	Side 2	Wattage		Load		Side 1	Side 2
			Side 1	Side 2	Side 1	Side 2		
Taxiway Centerline Narrow, bidirectional	10.9 VA	10.9 VA	15 W	15 W	7.9 VA	7.9 VA	18.8 VA	18.8 VA
Taxiway Centerline Wide, bidirectional	13.1 VA	13.1 VA	15 W	15 W	7.7 VA	7.7 VA	20.8 VA	20.8 VA

¹Values provided are for the "S" option non-monitored power only.



Note

- EQ fixtures:
 - The isolation transformer must have an additional 8 VA available above the fixture load for communication bandwidth. Size transformer to next size up to assure additional 8 VA coverage
 - Legacy BRITE II or AGLAS 2 systems — Order "M" power supply
- Fail-open fixtures:
 - The maximum rating for the isolation transformer is 150 W
- Additional voltage loss not included in the above table which must be factored into the circuit load calculation:
 - Primary cables will result in a higher CCR load
 - Longer secondary cables may result in a larger size isolation transformer requirement
- Efficiency of the isolation transformer depends on the manufacturer of the transformer

LED FAA L-852A/B/C/D/J/K(L) Taxiway Centerline and Lead-on/Exit

8-inch and 12-inch light fixtures without Arctic Kit (heater)

Fixture type - 1 cord set ¹	Fixture load	Isolation transformer		CCR load
		Wattage	Load	
Taxiway Centerline L-852(L), bidirectional	16.5 VA	15 W	7.9 VA	24.4 VA
Taxiway Centerline, L-852(L), unidirectional	14.3 VA	15 W	8.51 VA	22.8 VA

8-inch and 12-inch light fixtures with Arctic Kit (heater)

Fixture type - 1 cord set ¹	Fixture load	Isolation transformer		CCR load
		Wattage	Load	
Taxiway Centerline, L-852(L), bidirectional	55.1 VA	65 W	18.6 VA	73.7 VA
Taxiway Centerline, L-852(L), unidirectional	40.1 VA	45 W	13.8 VA	53.9 VA

¹Values provided are for the "S" option non-monitored power only.

LED RWSL: L-850T(L) Runway Takeoff/Hold and Intersection Light (THL/RIL) and L-852S(L) Runway Entry Light (REL)

8-inch and 12-inch light fixtures without Arctic Kit

Fixture type - 1 cord set ¹	Fixture load	Isolation transformer		CCR load
		Wattage	Load	
L-850T(L) THL/RIL Takeoff Hold Light	16.5 VA	25 W	10 VA	26.5 VA
REL Runway Entry Light	17.5 VA	25 W	9.8 VA	27.3 VA

8-inch and 12-inch light fixtures with Arctic Kit

Fixture type - 1 cord set ¹	Fixture load	Isolation transformer		CCR load
		Wattage	Load	
L-850T(L) THL/RIL Takeoff Hold Light	48.5 VA	65 W	14 VA	62.5 VA
REL Runway Entry Light	49.5 VA	65 W	14 VA	63.5 VA

¹Values provided are for the "S" option non-monitored power only.



Note

- EQ fixtures:
 - The isolation transformer must have an additional 8 VA available above the fixture load for communication bandwidth. Size transformer to next size up to assure additional 8 VA coverage
 - Legacy BRITE II or AGLAS 2 systems — Order "M" power supply
- Fail-open fixtures:
 - The maximum rating for the isolation transformer is 150 W
- Additional voltage loss not included in the above table which must be factored into the circuit load calculation:
 - Primary cables will result in a higher CCR load
 - Longer secondary cables may result in a larger size isolation transformer requirement
- Efficiency of the isolation transformer depends on the manufacturer of the transformer

Appendix A: Cable Loss

The formula for measuring the cable resistance **R** (in ohms) for a single conductor is calculated with following formula:

$$R = \rho \times (L / A)$$

Where:

- **R** = resistance of the cable (in ohms, Ω)
- **ρ** = resistivity of the conductor material (in ohm-meters, $\Omega\cdot\text{m}$)
- **L** = length of the conductor (in meters, m)
- **A** = cross-sectional area of the conductor (in square meters, m^2)

Example: for 1 km of 2.5 mm² copper conductor (where the the resistivity (ρ) is 1.72 10⁻⁸ (m^2), the resistance R is calculated as follows:

$$(1.72 \cdot 10^{-8}) \times 1000 / (2.5 \cdot 10^{-6} \text{ m}^2) = 6.88 \text{ ohms}$$

The loss (Watt) is then $R \times I^2$ or $6.88 \text{ ohms} \times 6.6^2 \text{ A}^2 = 299.69 \text{ W/km}$ or 0.299 W/m .

The loss (Watt) for a secondary cable with 2 conductors is thus $2 \times 0.299 = 0.599$ or 0.6 W/m .

As such we can calculate:

- Secondary cable for a 2.5 mm² Cu-wire (2 conductors): 0.6 W/m
- Secondary cable for a 4 mm² Cu-wire (2 conductors): 0.4 W/m
- Primary cable for a 6 mm² Cu-wire (1 conductor): 0.12 W/m

The cable between the isolation transformer and the lamp adds losses that cannot be ignored when dimensioning the circuits and selecting rating for secondary transformers and regulators.



WARNING

Cable lengths should not exceed 100 meters.

For a secondary cable of e.g., 20 m of 2.5 mm² CU-wire, $20 \text{ m} \times 0.6 \text{ W/m} = 12 \text{ W}$ equals the additional loss to be taken into account.

For a primary cable of e.g., 100 m of 6 mm² CU-wire, $100 \text{ m} \times 0.12 \text{ W/m} = 12 \text{ W}$ equals the additional loss to be taken into account.

Appendix B: Interoperability

Base installation – O-ring selection and retaining bolts 12-inch

The O-ring is required for 12-inch light fixtures. For corresponding 12-inch base, refer to the ordering code in the data sheet.



CAUTION

Use of incorrect combination of gaskets, bolts and nuts can cause multiple safety risks and severe damage to product.

To obtain a safe and watertight installation, the O-ring and retaining bolt stated in the document must be used.

In order to choose the correct gasket, bolts and nuts, you need to know what base the light fixture will be installed in.

Failure to follow these precautions can result in equipment damage and/or aircraft FOD.

Table 3: Interoperability matrix – 12-inch

Base type	Required O-ring	Bolt installation		Stud installation	
		Required dimension	Recommended torque ³	Required nut	Recommended torque ³
RELIANCE 12" 150 mm Safegate 12" 150 mm ERNI 12" ED12-190	O-ring D259, 3x5, 7 SP.013114/10pc SP.013115/100pc	1411.20.482	40 Nm+locking washer ²	1411.20.500	35 Nm
Thorn 12" 150 mm Thorn 12" 100mm		Metric screw kit 12" M10x25 mm	40 Nm+locking washer ²⁴	Self-locking nut kit 12" M10xH=100	35 Nm ⁴
ADB 12" Eurobase			21 Nm + Loctite 2701 or 638		21 Nm ¹
L-868 deep can with flange		1411.20.452 UNC screw kit	reference EB83	NA	NA

1. Do not use Loctite or washer with self-locking nut
2. Max height 2 mm
3. Do not use SO jacketed cord style 1
4. Only with non-roll over lights



Note

If the use of Loctite is not necessary or obligatory, then it is recommended to use a suitable lubricant when fastening the bolts. Use nickel or graphite grease, but do NOT use copper-based grease as it stimulates corrosion.

Base installation – O-ring selection and retaining bolts 8-inch



CAUTION

Use of incorrect combination of gaskets, bolts and nuts can cause multiple safety risks and severe damage to product. To obtain a safe and watertight installation, the O-ring and retaining bolt stated in the document must be used. In order to choose the correct gasket, bolts and nuts, you need to know what base the light fixture will be installed in.

Failure to follow these precautions can result in equipment damage and/or aircraft FOD.

Table 4: Interoperability matrix – 8-inch

Base type	Required O-ring	Bolt installation		Stud installation	
		Required dimension	Recommended torque ³	Required nut	Recommended torque ³
RELIANCE 8" 135 mm Thorn 8" 100 mm Thorn 8" 133 mm IDM 6494 120 mm Adapter ring SG/Thorn/ID 8"-12"	Red O-Ring SGE.SP24523/10 pc SGE.SP24526/100 pc	1411.20.522 Metric screw kit 8" M10x25mm	40 Nm+locking washer ²	1411.20.430 Self-locking nut kit 8" M10xH100	35 Nm
ERNI 8" EE08 150 mm ERNI 8" ED08 133 mm	Blue O-Ring SGE.SP24521/10 pc		21 Nm + Loctite 2701 or 638		
ADB 8" Eurobase Adapter ring ADB 8"-12"	SGE.SP24524/100 pc				
ADB 8" HPI	Grey O-Ring SGE.SP24522/10 pc SGE.SP24525/100 pc				21 Nm ¹

1. Do not use Loctite or washer with self-locking nut
2. Max height 2 mm
3. Do not use SO jacketed cord style 1

The pictures below show photos of the bases mentioned above and the frame shows the color of the intended gasket.

Figure 37: Shallow bases

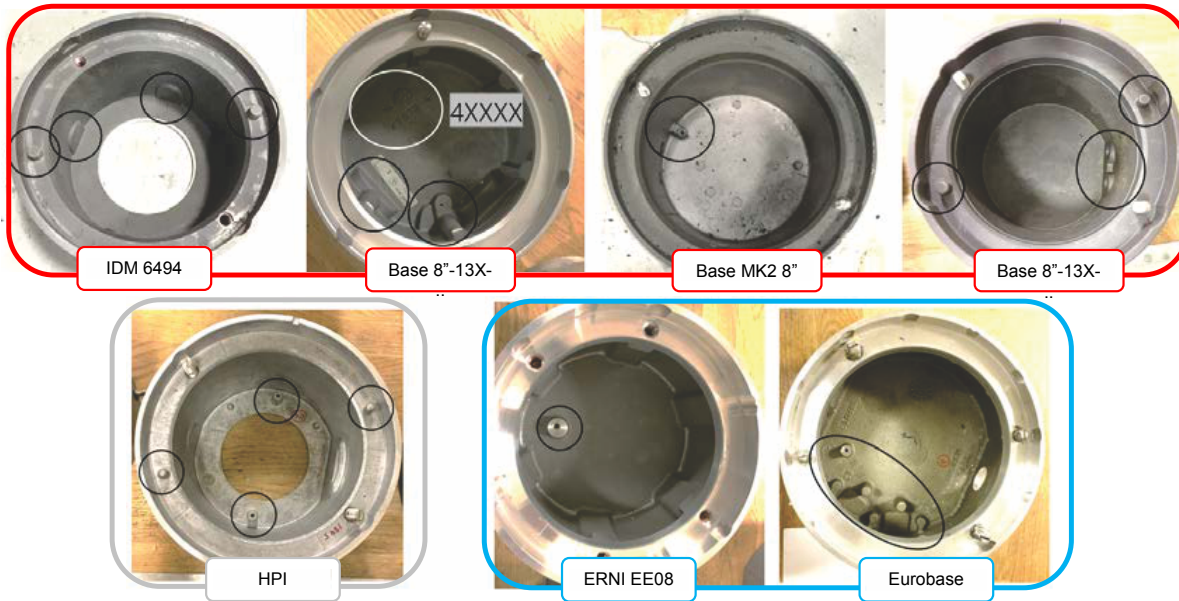

Appendix C: Winter Operations: Snow Plowing Guidelines for inset Lights

Introduction

Most ADB SAFEGATE light fixtures are low protrusion height and the risk to damage the light is less than with fixtures that protrude higher above ground. Reinforced prisms are optional available for certain fixtures, further increasing the scratch resistance for enhanced lifetime. Nevertheless, airport winter operations play a crucial role in protecting in-pavement airfield ground lights from damage by snowplows.

Airport operators should follow the specifications:

- FAA AC 150/5200-30D - Airport Winter Safety and Operations
- FAA AC 150/5220-20A - Airport Snow and Ice Control Equipment
- FAA AC 150/5340-26C - Maintenance of Airport Visual Aid Facilities
- FAA EB85 - Ductile Snowplow Protection Ring And Installation Procedures
- ACRP Report 123 - A Guidebook for Airport Winter Operations

The following instructions provide a summary of these specifications and give additional guidelines, next to the airport specific and general rules, on damage prevention of airfield inset lights during winter operations.

Anti- and De-icing Chemicals

Chemicals may be required to remove compacted snow from in-pavement light fixtures. However, extensive chemical use may damage in-pavement light fixtures and underground electrical components resulting in additional electrical maintenance requirements and costs. De-icing liquids should be used moderately; excessive use will have a negative impact on the environment and will contaminate the light outlet.

ADB SAFEGATE light fixtures are tested to work with common chemicals on the airfield such as:

- Potassium Acetate
- Potassium Formate
- Sodium Acetate
- Sodium Formate

The pH value of such chemical solutions should not exceed pH 11 to protect the light fixtures from corrosion and other damage.

Winter Operation Training

Most airports conduct dry-run winter operations training in advance of the winter season. Winter operation tests and simulations should be performed on designated and suitable sections of taxiways or runways equipped with the fittings to be tested. This will help to identify any potential problems and will avoid excessive damages on luminaries and maintenance vehicles during winter.

Snow and Ice Removal

To prevent damage of in-pavement lights during snow and ice removal a combination of different techniques should be used.

- In-pavement **lights should be turned on** at maximum intensity approx. 30-40 min. before the start of snow and ice removal. The purpose is to ensure melting of snow and ice formation at the light outlets before snow and ice removal.
- Anti-icing chemicals may be used to prevent ice bonding to the pavement surface. Once the ice has bonded to the pavement surface, approved de-icing chemicals may be used to melt through the ice pack and/or to break up or weaken the ice bond.

- For actual removal snowplows, rotary runway brooms and blowers should be used in combination. By principle: **Snowplows** should be used with the plow blade set at a small distance from the pavement surface for removal of the majority of snow and ice.
-



Note

Refer to the [Cutting Edge Height](#) paragraph of the [Snowplows](#) section.

Rotary runway brooms are more effective at removing snow from in-pavement lighting fixtures than plow blades and should be used for removal of the last layer.

- If snow removal is a frequent winter job, the use of **high-strength steel snowplow rings** is advised to better withstand the impact of snow plowing and to protect aluminum alloy in-pavement lights. Please refer to FAA Engineering Brief 85 for further information concerning design and installation of snowplow rings.
-



IMPORTANT

The most effective counter-measures in case of damages to in-pavement lights are to slightly increase the plow blade/cutting edge height above ground and reduction of snowplow speed.

Snowplows

Material and Structure of the Cutting Edge

To protect in-pavement lights from damage during the snow removal it is important that the snowplows are equipped with plastic cutting edges.

- The plastic cutting edge should be made of polyurethane, rubber or material of similar consistence and characteristics.
- The plastic cutting edge should consist of a minimum of plastic segments, accurately aligned and free of steps between them.

Figure 38: Snowplow blade with well aligned segments



- It is not recommended to have steps between the plastic segments.
- Vertical or horizontal steps between the plastic segments will increase the risk of luminaire damage. Hitting inset fixtures with steps between plastic segments should be avoided.
- Check regularly for wear and abrasion marks on plastic cutting edges.
- The plastic cutting edges should be replaced when worn down to the wear limit marking. Wear down to the metal portion of the plow should be avoided in any case.

Figure 39: Snowplow blade with wear and steps between segments



Cutting Edge Height

- In order to prevent damage to in-pavement lights and to protect vehicle operators from uneven pavement joints and edges, the plow blade / cutting edge should be set slightly above ground level.
- In a stationary position the clearance between the plastic cutting edge and the pavement should be 10 to 15 mm. Any remaining snow/ice should be removed with rotary brooms and/or de-icing or anti-freeze agent. No clearance between the plastic cutting edge and the pavement may damage in-pavement lights.

Figure 40: Snowplow blade without clearance



- Use casters, shoes and/or support wheels on plow moldboards and on the front of rotary plows to stabilize the plow blade and to support maintaining a pre-defined clearance between the snowplow cutting edge and the pavement during operation.

Figure 41: Snowplow with support wheels



Figure 42: Snowplow without support wheels



- Do not use guidance and support wheels that are made of steel.
- Any protruding bolts and metal elements whose clearance to pavement is less than 20 mm during operation shall be avoided

Speed and angle of the plow

High snowplow speeds can damage the light outlets and prisms could eventually break. The allowable speed should be determined before start of operation, based on the configuration of the equipment.

- A speed of greater than 40 km per hour is not advised.
- Whenever snowplows must traverse over in-pavement light fixtures, they should be traveling at less than 10 km per hour or should lift the blades clear of the fixture.
- Some plow blades are made of a series of movable segments. These segments are spring loaded and are able to move vertical to follow uneven pavement. Do not block blade segment mechanics which allow for such movement.
- Adjust and regularly control plow angles as per manufacturer recommendation.
- If frequent prism damages exist during the winter operations it may be necessary to reduce the snowplow's swivel angle versus the driving line of the vehicle.
- Different temperatures and snow quantities influence the parameters described. Applied settings need to follow supplier recommendations.

Rotary brooms

Rotary runway brooms can be used for both snow and ice removal.

- **Snow:** Rotary runway brooms are more effective at removing snow from in-pavement light fixtures than plow blades.
- **Ice:** The type of brooms used to remove a layer of ice is important since in some cases the broom may actually "polish" the ice, thus reducing traction.

Bristles for rotary brooms are available as steel or poly bristles.

- Steel bristles cut the ice surface while, poly bristles flip / wipe away snow. However, using steel bristles will faster scratch and wear out especially the glass prisms of in-pavement lights, negatively impacting the light photometry.

- When possible avoid using steel bristles, or run rotary brooms with a mix of steel and poly bristles (e.g. 1/3) to reduce the wear and damage to in-pavement lights.
- Check for adequate contact pressure; evaluate during pre-winter dry-run tests.
- Check for bristle wear according to manufacturers recommendation and replace the brooms when necessary. If worn down the bristles will be more stiff and will increase the wear on the light fixtures and especially the prisms significantly.
- When possible avoid using silica or glass sand. If necessary to use, remove it as soon as operational conditions allow. When removing sand use caution with rotating brushes (rotate at low speed).
- Use of reinforced prisms, which are about four times as hard as regular glass prisms, can significantly increase the prism maintenance interval, though scratches will still occur over time.

Steel brushes:

- The use of steel brushes is very effective for snow removal, it is however very important to pay special attention on how it is being used and replace the brushes when they are worn to make sure that the brushes are not too rigid and risk decreasing the service life of the prisms.



Tip

We recommend the use of "sapphire"TM prism (available in the AXON range) which is about four times harder than a regular glass prism if steel brushes are used.

The use of sapphire prisms will not make the prisms scratch proof as scratches can still occur over time but it will increase the service interval and service life of the prism.

Appendix D: SUPPORT

Our experienced engineers are available for support and service at all times, 24 hour/7 days a week. They are part of a dynamic organization making sure the entire ADB SAFEGATE is committed to minimal disturbance for airport operations.

ADB SAFEGATE Support

Technical Support – Global

Customers in Europe, the Middle East, Africa or Asia Pacific are more than welcome to our portal for technical support. Trained in all areas of system issues, troubleshooting, quality control and technical assistance, our highly experienced Technical support specialists are available 24 hours a day, seven days a week to provide assistance over the phone. In the Americas, we also offer live technical support.

Live Technical Support – Americas

If at any time you have a question or concern about your product, contact ADB SAFEGATE's US-based technical support specialists, available 24 hours a day, seven days a week, to assist you via phone.

ADB SAFEGATE Americas Technical Service & Support (US & Canada) :+1-800-545-4157

ADB SAFEGATE Americas Technical Service & Support (Canada): +1-905-631-1597

ADB SAFEGATE Americas Technical Service & Support (International): +1-614-861-1304

We can also be reached via email during regular business hours:

Airfield and Gate: techservice.us@adbsafegate.com

Gate: gateservice.us@adbsafegate.com

We look forward to working with you!

Before You Call

When you have an airfield lighting or system control system problem, prior to calling, please ensure the following:

- Review the product's manual and troubleshooting guide.
- Be located with the product ready to troubleshoot.
- Have all necessary information available: airport code/company name, customer id number, contact phone number/email address, product/part number.
- Have a True RMS meter available and any other necessary tools.

When calling about an issue with Safedock A-VDGS, we can serve you better if you collect the following information before you call:

- Relevant information regarding the issue you are calling about, such as gate number, flight number, aircraft type and time of the event.
- What, if any, actions have been taken to resolve the issue prior to the call.
- If available, provide a CCTV recording of the incident to aid in aligning the information from the Safedock log file.

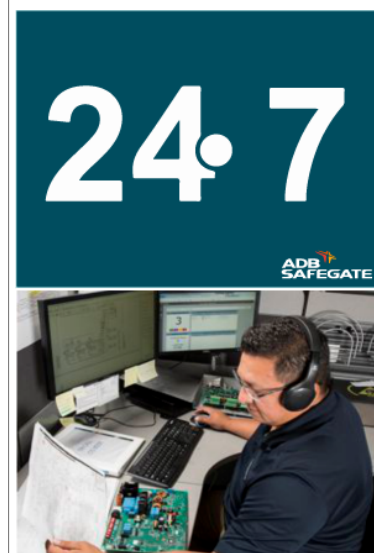

Note

For more information, see www.adbsafegate.com, contact ADB SAFEGATE Support via email at support@adbsafegate.com or Europe: +32 2 722 17 11

Americas: +1 614 861 1304. Press 3 for technical service or press 4 for sales support.

China: +86 (10) 8476 0106

Middle East and Africa: +971 4 452 7575

D.1 ADB SAFEGATE Website

The ADB SAFEGATE website, www.adbsafegate.com, offers information regarding our airport solutions, products, company, news, links, downloads, references, contacts and more.

D.2 Recycling

D.2.1 Local Authority Recycling

The disposal of ADB SAFEGATE products is to be made at an applicable collection point for the recycling of electrical and electronic equipment. The correct disposal of equipment prevents any potential negative consequences for the environment and human health, which could otherwise be caused by inappropriate waste handling. The recycling of materials helps to conserve natural resources. For more detailed information about recycling of products, contact your local authority city office.

D.2.2 ADB SAFEGATE Recycling

ADB SAFEGATE is fully committed to environmentally-conscious manufacturing with strict monitoring of our own processes as well as supplier components and sub-contractor operations. ADB SAFEGATE offers a recycling program for our products to all customers worldwide, whether or not the products were sold within the EU.

ADB SAFEGATE products and/or specific electrical and electronic component parts which are fully removed/separated from any customer equipment and returned will be accepted for our recycling program.

All items returned must be clearly labeled as follows:

- For RoHS/WEEE Recycling
- Sender contact information (Name, Business Address, Phone number).
- Main Unit Serial Number.

ADB SAFEGATE will continue to monitor and update according for any future requirements for EU directives as and when EU member states implement new regulations and or amendments. It is our aim to maintain our compliance plan and assist our customers.

Company Addresses

ADB SAFEGATE, Belgium	ADB SAFEGATE BV Leuvensesteenweg 585 B-1930 Zaventem Belgium
Contact:	
Tel.: +32 2 722 17 11	Email: marketing@adbsafegate.com
Fax: +32 2 722 17 64	Internet: www.adbsafegate.com
ADB SAFEGATE, Americas	ADB SAFEGATE Americas, LLC 700 Science Blvd Gahanna, OH 43230 USA
Contact:	
Tel.: +1 (614) 861 1304	Email: sales.us@adbsafegate.com
Fax: +1 (614) 864 2069	Internet: www.adbsafegate.com
ADB SAFEGATE, Sweden	ADB SAFEGATE Sweden AB Djurhagegatan 19 SE-213 76 Malmö Sweden
Contact:	
Tel.: +46 (0)40 699 17 00	Email: marketing@adbsafegate.com
Fax: +46 (0)40 699 17 30	Internet: www.adbsafegate.com
ADB SAFEGATE, China	ADB SAFEGATE Airfield Technologies Ltd. China Unit 603, D Block, CAMIC International Convention Center, No 3, Hua Jia Di East road, ChaoYang district, Beijing 100102 P.R. China
Contact:	
Tel.: +86 (10) 8476 0106	Email: china@safegate.com
Fax: +86 (10) 8476 0090	Internet: www.adbsafegate.com
ADB SAFEGATE, Germany	ADB SAFEGATE Germany GmbH Konrad-Zuse-Ring 6, D-68163 Mannheim Germany
Contact:	
Tel.: +49 (621) 87 55 76-0	Email: marketing@adbsafegate.com
Fax: +49 (621) 87 55 76-55	Internet: www.adbsafegate.com

WWW.ADBSAFEGATE.COM

Empowering the Airside Evolution

SMARTER. BETTER. NOW.

