



Model 2030

Micro Response Anemometer

PRODUCT MANUAL
2030/Rev C

**ADB
SAFEGATE**

A.0 Disclaimer / Standard Warranty

CE certification

The equipment listed as CE certified means that the product complies with the essential requirements concerning safety and hygiene. The European directives that have been taken into consideration in the design are available on written request to ADB SAFEGATE.

ETL certification

The equipment listed as ETL certified means that the product complies with the essential requirements concerning safety and C22.2 No.180:13 (R2018) regulations. The CSA directives that have been taken into consideration in the design are available on written request to ADB SAFEGATE.

All Products Guarantee

ADB SAFEGATE will correct by repair or replacement per the applicable guarantee below, at its option, equipment or parts which fail because of mechanical, electrical or physical defects, provided that the goods have been properly handled and stored prior to installation, properly installed and properly operated after installation, and provided further that Buyer gives ADB SAFEGATE written notice of such defects after delivery of the goods to Buyer. Refer to the Safety section for more information on Material Handling Precautions and Storage precautions that must be followed.

ADB SAFEGATE reserves the right to examine goods upon which a claim is made. Said goods must be presented in the same condition as when the defect therein was discovered. ADB SAFEGATE further reserves the right to require the return of such goods to establish any claim.

ADB SAFEGATE's obligation under this guarantee is limited to making repair or replacement within a reasonable time after receipt of such written notice and does not include any other costs such as the cost of removal of defective part, installation of repaired product, labor or consequential damages of any kind, the exclusive remedy being to require such new parts to be furnished.

ADB SAFEGATE's liability under no circumstances will exceed the contract price of goods claimed to be defective. Any returns under this guarantee are to be on a transportation charges prepaid basis. For products not manufactured by, but sold by ADB SAFEGATE, warranty is limited to that extended by the original manufacturer. This is ADB SAFEGATE's sole guarantee and warranty with respect to the goods; there are no express warranties or warranties of fitness for any particular purpose or any implied warranties of fitness for any particular purpose or any implied warranties other than those made expressly herein. All such warranties being expressly disclaimed.

Standard Products Guarantee

Products manufactured by ADB SAFEGATE are guaranteed against mechanical, electrical, and physical defects (excluding lamps) which may occur during proper and normal use for a period of two years from the date of ex-works delivery, and are guaranteed to be merchantable and fit for the ordinary purposes for which such products are made.

NOTE



See your applicable sales agreement for a complete warranty description.

Replaced or repaired equipment under warranty falls into the warranty of the original delivery. No new warranty period is started for these replaced or repaired products.

FAA Certified products manufactured by ADB SAFEGATE

ADB SAFEGATE L858 Airfield Guidance Signs are warranted against mechanical and physical defects in design or manufacture for a period of 2 years from date of installation, per FAA AC 150/5345-44 (applicable edition).

ADB SAFEGATE LED products (with the exception of obstruction lighting) are warranted against electrical defects in design or manufacture of the LED or LED specific circuitry for a period of 4 years from date of installation, per FAA EB67 (applicable edition). These FAA certified constant current (series) powered LED products must be installed, interfaced and powered with and through products certified under the FAA Airfield Lighting Equipment Program (ALECP) to be included in this 4 (four) year warranty. This includes, but is not limited to, interface with products such as Base Cans, Isolation Transformers, Connectors, Wiring, and Constant Current Regulators.

Revision History

Revision	Date	Summary of Changes
A	2011 Mar 11	Initial release
B	2021 Apr 2	Updated Specifications to current format
C	2025 Apr 1	ADB SAFEGATE (ECP#ADBSG-0001)

Contents

1. Introduction.....	5
2. Installation.....	6
2.1 Assembly.....	6
2.2 Site Selection.....	6
2.3 Mounting.....	7
2.4 Orientation.....	7
2.5 Wiring.....	7
3. Theory Of Operation	8
4. Calibration	9
5. Maintenance.....	10
5.1 Inspecting The Bearings.....	10
5.2 Precautions.....	10
5.3 Replacing The Bearings.....	10
5.4 Maintenance Kit.....	11
5.5 AWOS Periodic Maintenance.....	11
5.5.1 Tools and Equipment Required.....	11
5.5.2 Monthly Maintenance.....	11
5.5.3 Quarterly Maintenance.....	11
5.5.4 Annual Maintenance	11
6. Specifications	12
7. Warranty	13
8. Drawings	14

1. Introduction

The Model 2030 Micro Response Anemometer is a highly responsive three-cup anemometer that uses a photon-coupled chopper to produce an output pulse with a frequency proportional to wind speed.

- The threshold of the anemometer is 1 mile per hour.
- The entire anemometer assembly, with the exception of the photon-coupled chopper, is made from stainless steel, anodized aluminum, and carbon/graphite composite.
- A quick-release waterproof connector is provided.

The Model 2030 Anemometer can be used in conjunction with several interfaces:

- ADB Safegate'S Q-Net data acquisition system
- ADB Safegate'S Automated Weather Observing System (AWOS), interfaced to the Model 1798 Sensor Interface Processor (SIP)
- 1190 series data acquisition systems
- Model 1220 or Model 1280 Wind Speed Signal Conditioning Modules, which provide an analog output proportional to wind speed.

2. Installation

This instrument is thoroughly tested and fully calibrated at the factory and is ready for installation.

2.1 Assembly

With the exception of installing the cup assembly, the Model 2030 Micro Response Anemometer is ready for mounting. Install the cup assembly as described in the steps below.

Loosen the two set screws with a 1/16" Allen wrench, and slide the cup assembly over the anemometer shaft. Be certain that the flat face of the shaft faces toward the set screws.

The cup assembly hub should slide down over the shaft and body and seat against the shaft ring. When correctly in place, there should be no drag between the skirt of the hub and the shoulder of the body. Tighten both set screws to 7 in. lbs.

Spin the cup wheel by hand to assure smooth operation. The cup wheel should coast to a smooth stop.

2.2 Site Selection

Location of the sensor is critical for accurate wind measurements. The standard exposure of an anemometer or vane over open, level terrain is 10 meters above the ground. Open, level terrain is defined as level ground with no obstruction within 300 meters. In locations where obstructions are not large, such as residential areas, and are distributed more or less evenly, the sensor may be placed at an effective height of $h + 10$ meters, where h is the approximate height (in meters) of the various obstacles. As an example, in a location where trees and buildings reach to about 5 meters, the sensors must be placed on a 15-meter mast to avoid erroneous results.

In areas where large obstructions do exist within 300 meters of the sensor, the following table can be used to calculate the proper height of the sensor (h is the height of the obstruction).

Distance to Obstruction (h)	Minimum Height of Anemometer Above Ground Level
h	1.75h to 2.25h
5h	1.67h
10h	1.50h
20h	1.25h
25h	1.13h
30h	h

* Handbook of Meteorological Instruments, 2nd Edition. Measurement of Surface Wind, Volume 4. London, HMSO: 1981

Table 1*

Example:

If there is a building 10 meters high and 50 meters away, the anemometer should be at least 16.7 meters above the ground. But, if the same building is 200 meters away, the sensor could be lowered to 12.5 meters.

When the sensor is mounted on a building, the building itself disturbs the wind flow and must be taken into account before installation. For large buildings, other than buildings such as lighthouses and skyscrapers, the sensor must be mounted as far away from the edge of the building as possible and at a height **at least ¾ the height of the building**. Thus, with a building 28 meters high, a rooftop tower at least 21 meters high should be used.

2.3 Mounting

The Model 2030 Micro Response Contact Anemometer mounts directly to the Model 2023 Crossarm without any additional accessories. The crossarm is generally used to mount one each Model 2030 Anemometer and a Model 2020 Vane to form a wind speed and direction measurement set. If the Model 2030 Anemometer is to be mounted separately, a Model 20231 Mast Adapter should be ordered as an accessory. Both the Model 2023 Crossarm and the Model 20231 Mast Adapter will mount on a mast with an outside diameter of 1" (25.4 mm) or ¾" Schedule 40 pipe. Set screws are provided in either case for securing to the mast. The lower part of the anemometer body will slip over the pin on the crossarm or the mast adapter. When in place, tighten all mounting screws.

For AWOS installations, refer to the 2020/2030 **AWOS Mounting** figure in the *Drawings* chapter of this manual.

2.4 Orientation

The anemometer should be mounted with its axis as close to vertical as possible to provide for the best measurement of horizontal wind movement. If the sensor must be removed from the mounting adapter or crossarm, loosen only the Allen head screw on the sensor base and slide the sensor off the adapter. Do not remove the mounting pin from the crossarm or the mast adapter from the mast since these serve to maintain sensor alignment.

2.5 Wiring

Figure 1 shows the sensor wiring when connecting to the Model 1190 DCP, as used in AWOS systems. Cable number 20306 can be ordered from ADB Safegate for direct connection. The cable comes with a mating connector at the sensor end and bare wires for connection at the DCP's terminal block TB2. For other applications, when cable 20306 is not used, refer to Figure 1 as a wiring guide.

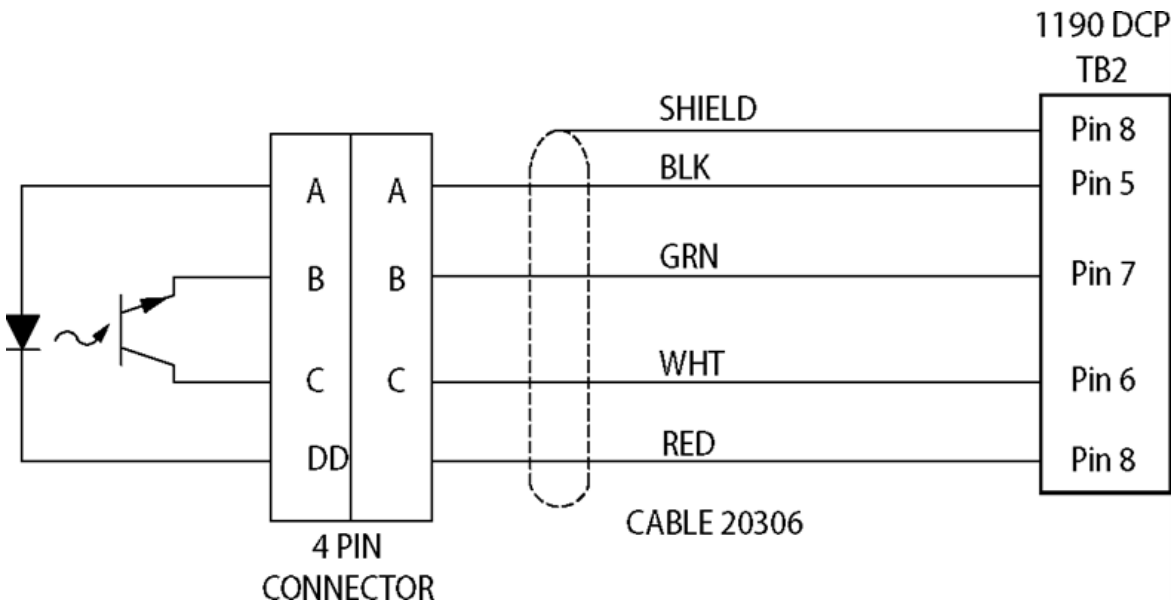

Figure 1. Sensor Wiring in Model 1190 DCP

3. Theory Of Operation

A light emitting diode in combination with a light sensitive transistor is mounted directly to the anemometer connector. A slotted wheel connected to the anemometer shaft rotates with the shaft and interrupts the light beam between the light emitting diode and the phototransistor. This interruption causes a change in the transistor's collector to emitter current.

The current changes are amplified and conditioned by the Model 1220 Wind Speed Signal Conditioning Module, which provides an analog output signal proportional to wind speed.

4. Calibration

The slotted wheel contains 30 slots, providing thirty electrical pulses per revolution. The output frequency of the anemometer may be determined by the following equation:

$$F_{Hz} = 9.901(V_{mph} - 0.476)$$

Or the velocity may be determined as follows:

$$V_{mph} = \frac{F_{Hz}}{9.901} + 0.476$$

$$V_{knots} = \frac{F_{Hz}}{11.395} + 0.648$$

where F_{Hz} is the frequency in Hertz, V_{mph} is the velocity in miles/hour, and V_{knots} is the velocity in knots.

Calibration data in Table 2 were compiled from tests in which the anemometer was operated in a wind tunnel equipped with NIST-traceable measuring instruments.

Frequency (Hz)	Shaft Speed (rpm)	Wind Speed (mph)	Wind Speed (m/s)	Wind Speed (knots)
25	50	3.27	1.46	2.84
30	60	3.78	1.69	3.28
150	300	15.90	7.11	13.82
450	900	46.20	20.65	40.14
750	1500	76.50	34.20	66.47
900	1800	91.65	40.97	79.64
983	1965	100.00	44.70	86.89
1100	2200	111.85	50.00	97.19

Table 2. Model 2030 Anemometer Calibration Table

The Model 1220 Wind Speed Signal Conditioning Module is equipped with a calibration feature consisting of a constant frequency oscillator and a switch to apply the oscillator to the signal conditioning circuitry. This feature allows the operator to quickly set up the output signals for zero and full-scale values. Refer to the Model 1220 manual for additional information.

To verify calibration of the anemometer, rotate the anemometer shaft at one of the known rpm values shown in Table 2 and measure the sensor output with a frequency counter or oscilloscope. If a Model 1220 module is used, place the module into OPERATE mode and measure the frequency between the BLK/WHT and the BLK test points (TP110 and TP100). The measured frequency should equal the value indicated in the calibration table.

miles per hour	knots	meters per second	feet per second
mph x 0.868 = knots	knots x 1.152 = mph	m/s x 2.237 = mph	ft/s x 0.682 = mph
mph x 0.447 = m/s	knots x 0.515 = m/s	m/s x 1.943 = knots	ft/s x 0.592 = knots
mph x 1.467 = ft/s	knots x 1.689 = ft/s	m/s x 3.281 = ft/s	ft/s x 0.305 = m/s

Table 3. Wind Speed Conversion Factors

5. Maintenance

Maintenance of the sensor consists mainly of checking the bearings for wear, and replacing them as necessary.

For maintenance of a sensor as part of an AWOS system, refer to the **AWOS Periodic Maintenance** section below.

5.1 Inspecting The Bearings

The anemometer bearings should be inspected for wear periodically. The bearings are sealed and protected to prevent dirt and moisture from entering. With time, however, the seals will no longer prevent dirt from entering the bearing race and the bearings may fail. When this happens, the sensor will no longer rotate freely. The bearings can be replaced in the field or the anemometer can be returned to ADB Safegate for servicing.

To inspect the bearings, turn the anemometer cup assembly to check that it turns freely and smoothly. If it does not, replace the bearings as described below.

5.2 Precautions

Since corrosion is the main problem associated with wind sensors, apply a thick coating of silicon lubricant to the connector shell after the connector is attached and in place. Also, use an anti-seize thread compound such as Loctite Silver Grade Anti-Seize Compound on all screws and fasteners whenever disassembly of the sensor is required. The use of these lubricants will make servicing of the sensor easier and will prevent seizure of the fastening hardware. It is also advisable to apply lubricant to the mounting adapter surfaces prior to final sensor installation. A commercial grade lubricant recommended for use is DOOR-EASE, available at hardware and automotive stores. In addition to these precautions, check that the drain hole in the base of the sensor is free of debris so that water drains away rather than collecting within the sensor.

5.3 Replacing The Bearings

Follow the steps below to replace the bearings in the field.

1. Remove the cup wheel with a 1/16" Allen wrench.
2. Remove the electrical receptacle/photon coupled chopper assembly by removing the four 4-40 screws and sliding the entire unit out.
3. Remove the lower body section by removing three 6-32 screws.
4. Remove the E-clip from the shaft at the top of the unit and slide the entire shaft down and out of the unit, taking care not to bend the shaft.
5. Lift the upper bearing out by working a knife edge under the flanged outer race.
6. Using a rod of about 1/4" diameter passed down from the top, carefully knock the lower bearing out.
7. Clean all parts and install new bearings. Press the bearings in place by applying pressure to the outer race only. The bearing could be damaged by pressing against the inner race.
8. Re-assemble all parts in the reverse order of disassembly. Check for free and smooth rotation of the shaft before and after installing the cup wheel. The receptacle/photon- coupled chopper assembly should be installed with the large connector key toward the top of the unit. Wipe the lens areas of the chopper clean with a soft cloth prior to re-assembly.
9. Should there be any problems with the photon-coupled chopper, replace the entire connector/ chopper assembly. Check for proper excitation current polarity and phototransistor circuit polarity prior to connecting power to the new assembly.

Use great care in disassembly and re-assembly of the sensor. Never use excessive force to make parts fit together. Over-tightening of fasteners will either break the fastener or damage the machined threads of the sensor.

Any difficulties encountered during servicing that are not correctable by the user should be referred to the ADB Safegate Customer Service Department.

5.4 Maintenance Kit

A maintenance kit (P/N M488141) is available for the Model 2030 that provides the parts necessary for basic upkeep of the instrument. The kit includes those parts that are the most susceptible to wear, such as bearings and set screws. To order this kit, contact ADB Safegate and specify Part Number M488141.

5.5 AWOS Periodic Maintenance

Periodic maintenance of AWOS sensors is divided into three categories: monthly maintenance, quarterly maintenance, and annual maintenance. The listed maintenance routines are performed according to that schedule.

5.5.1 Tools and Equipment Required

- ½" wrench
- Silicon lubricant
- Non-corrosive lubricant (bee's wax)
- Model 1231 run-up motor

5.5.2 Monthly Maintenance

Monthly maintenance of the Model 2030 consists of visually verifying that the cups are moving freely and that the displayed wind speed is reasonable.

5.5.3 Quarterly Maintenance

Quarterly maintenance of the Model 2030 is identical to the monthly maintenance procedure: visually verify that the cups are moving freely and that the displayed wind speed is reasonable.

5.5.4 Annual Maintenance

During annual maintenance, perform the following procedures in addition to those outlined for monthly and quarterly maintenance.

1. Set the DCP's LCD display to display wind speed, and verify that the displayed wind speed is reasonable.
2. Remove the anemometer cup assembly by loosening the set screw on the side of the cup assembly collar.
3. Connect a Model 1231 run-up motor to the anemometer shaft and power the motor on. The DCP's LED display should read between 79 and 81 knots.
4. Replace the cup assembly.
5. Inspect the anemometer cups for damage, and replace if necessary.
6. *(The following test should be performed in windless conditions. If one person is performing the test alone, the anemometer will need to be removed from the tower and connected to a test cable within sight of the DCP display.)*
With the cup assembly in place, spin the cups by hand until the DCP display reads greater than 5 knots. After releasing the cups, they will slow and the displayed speed will gradually decrease. If the display reads 2 knots or less while the cups are still turning, the bearings are good. If the cups stop before slowing to a speed of 2 knots or less, replace the bearings.
7. Remove the sensor from the mounting bracket by loosening the clamp screw located at the base of the unit.
8. Clean the drain hole on the bottom of the sensor to ensure that debris does not prevent water from draining out of the sensor.
9. Use an anti-seize thread compound such as Loctite Silver Grade Anti-Seize Compound on the clamp screw and reinstall the sensor. The sensor mounting hole should be aligned with the pin on the base of the mounting bracket.
10. Inspect all mounting hardware and cable assemblies for wear and damage. Replace as necessary.
11. Apply a thick coating of silicon lubricant to the connector shell after the connector is attached and in place. Use a non-corrosive lubricant such as bee wax on all screws and fasteners. The use of these lubricants will make future servicing easier.

6. Specifications

Parameter	Specification
Sensor Type	3-cup assembly, carbon graphite composite, 2" diameter cups
Transducer	Light Chopper
Light Source	LED
Excitation	12 V DC, 25 mA
Output	30 pulses/rev, 900 Hz @ 88.8 mph
Range	0–75 m/s (0–168 mph, 0–156 kt)
Threshold	0.2 m/s (0.5 mph)
Accuracy	±1% (±0.15 mph)
Delay Distance	1.5 m (5 ft)
Materials	Stainless steel and anodized aluminum
Operating Temp. Range	-40°C to +60°C
Turning Radius	97 mm (3.8")
Mounting	Direct to crossarm or w/adaptor to 1" (25 mm) O.D. mast
Body Size	305 x 70 mm (12" high x 2.75" diameter)
Weight	1.1 kg (2.5 lb)
Shipping Weight	3.2 kg (7 lb)

7. Warranty

Unless specified otherwise, ADB Safegate (the Company) warrants its products to be free from defects in material and workmanship under normal use and service for one year from date of shipment, subject to the following conditions:

- a. The obligation of the Company under this warranty is limited to repairing or replacing items or parts which have been returned to the Company and which upon examination are disclosed, to the Company's satisfaction, to have been defective in material or workmanship at time of manufacture.
- b. The claimant shall pay the cost of shipping any part or instrument to the Company. If the Company determines the part to be defective in material or workmanship, the Company shall prepay the cost of shipping the repaired instrument to the claimant. Under no circumstances will the Company reimburse claimant for cost incurred in removing and/or reinstalling replacement parts.
- c. The warranty shall not apply to any Company products which have been subjected to misuse, negligence, or accident.
- d. This warranty and the Company's obligation thereunder is in lieu of all other warranties, express or implied, including warranties of merchantability and fitness for a particular purpose, consequential damages, and all other obligations or liabilities.

No other person or organization is authorized to give any other warranty or to assume any additional obligation on the Company's behalf, unless made in writing and signed by an authorized officer of the Company.

8. Drawings

The following pages include reference drawings to assist in installation and maintenance of this instrument.

REV		ECN		REVISIONS	DWG NO.	2030-003
REV	ECN	DESCRIPTION	DATE	APPROVED		
B	-	-	9-82			
C	-	-	1-83			
D	4251	ADD DETAIL A, LABELS, NOTES 1 THRU 8 & HARDWARE	10-4-93	SP		
E	4538	DELETED: ITEM 1 CONNECTOR AND ITEM 8 SET SCREW, ADDED: ITEM 8, NUT, 2X & NOTE 9 & 10	21NOV95	KAH		
F	4738	ADD CE LABEL IT-21 & NOTE 11	10/97	PK		
G	5016	DEL IT-11 & SHOW AS P/O IT-13, DEL NOTE 2	4/03	PK		
H	5152	ADD NOTE 12 AND REVISE NOTE 3	12-13-04	J.CONNER		
J	1369	REVISED ITEM 18	12-18-07	J.CONNER		

NOTES: UNLESS OTHERWISE SPECIFIED;

- 1 APPLY SILICONE GREASE TO O-RING.
- 2 DELETED
- 3 COAT SCREW THREADS WITH ANTI-SEIZE COMPOUND, LOCTITE SILVER GRADE, ANTI-SEIZE, OR EQUIV.
- 4 POSITION ITEM 16 WHEEL ASSEMBLY VERTICALLY TO ALIGN WITH GAP IN PHOTO DETECTOR PART OF ITEM 14.
- 5 INSTALL SPACERS ITEM 17 AS REQUIRED TO PROVIDE FOR SMOOTH ROTATION OF SHAFT WITHOUT EXCESSIVE END TO END MOVEMENT OF SHAFT. USUALLY 1 OR 2 SPACERS ARE SUFFICIENT.
- 6 INSTALL RECEPTACLE ITEM 14 TO UPPER BODY ITEM 12 WITH LARGE KEYWAY OF RECEPTACLE TOWARD TOP OF ASSEMBLY.
- 7 INSTALL LABELS OPPOSITE RECEPTACLE. IDENTIFY AS MODEL 2030 AND SERIALIZE.
- 8 DO NOT INSTALL CUP ASSEMBLY ITEM 18 AT THIS TIME.
- 9 MATING CONNECTOR, T210003, NOT INCLUDED IN THIS ASSY.
- 10 APPLY A SMALL AMOUNT OF LOCTITE 290 TO THREADS AFTER ASSEMBLY.
- 11 AFFIX 1/2" SQUARE BLACK-ON-SILVER CE LABEL (ITEM 21) AS SHOWN.
- 12. AFTER ASSEMBLY IS COMPLETE, BOX THE SENSOR BODY IN A 15 3/4 X 3 1/4 X 3 1/4 BI-PANEL FOLDED CARDBOARD BOX. OBTAIN BOXES FROM SHIPPING.

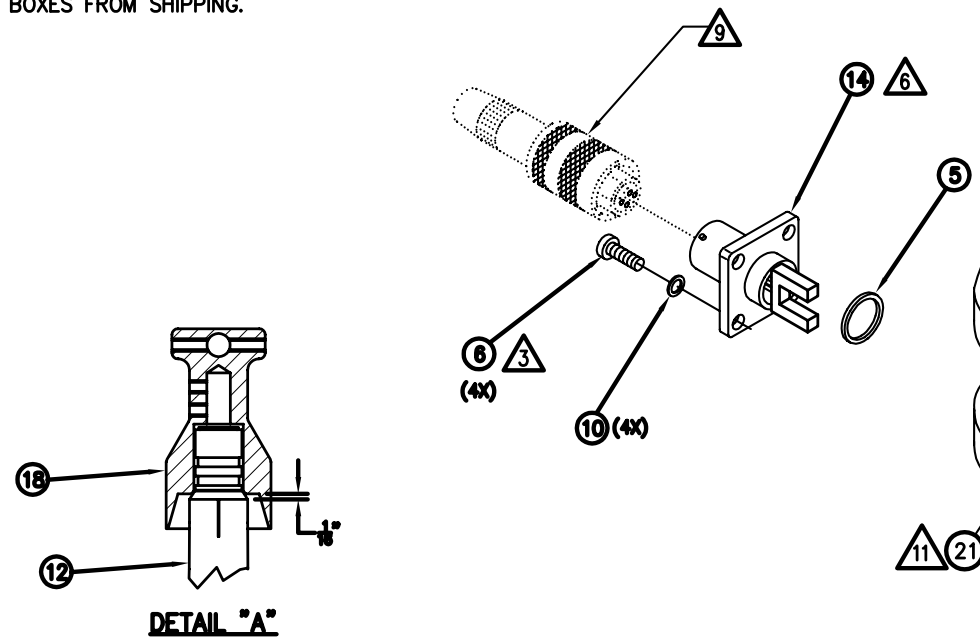
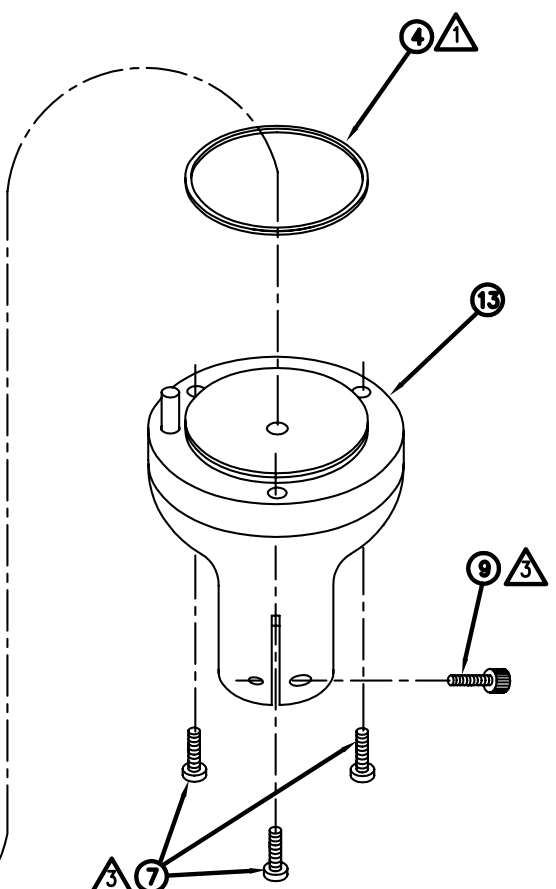
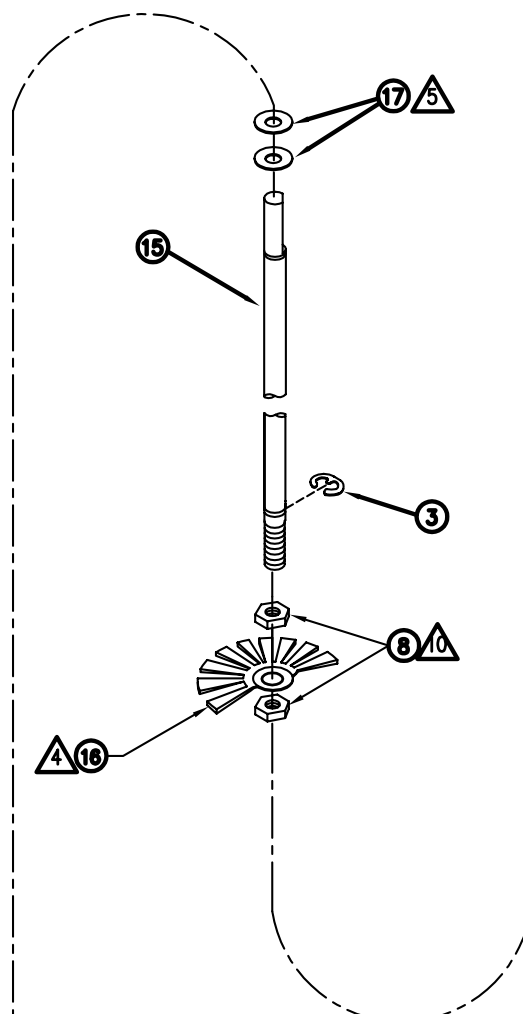
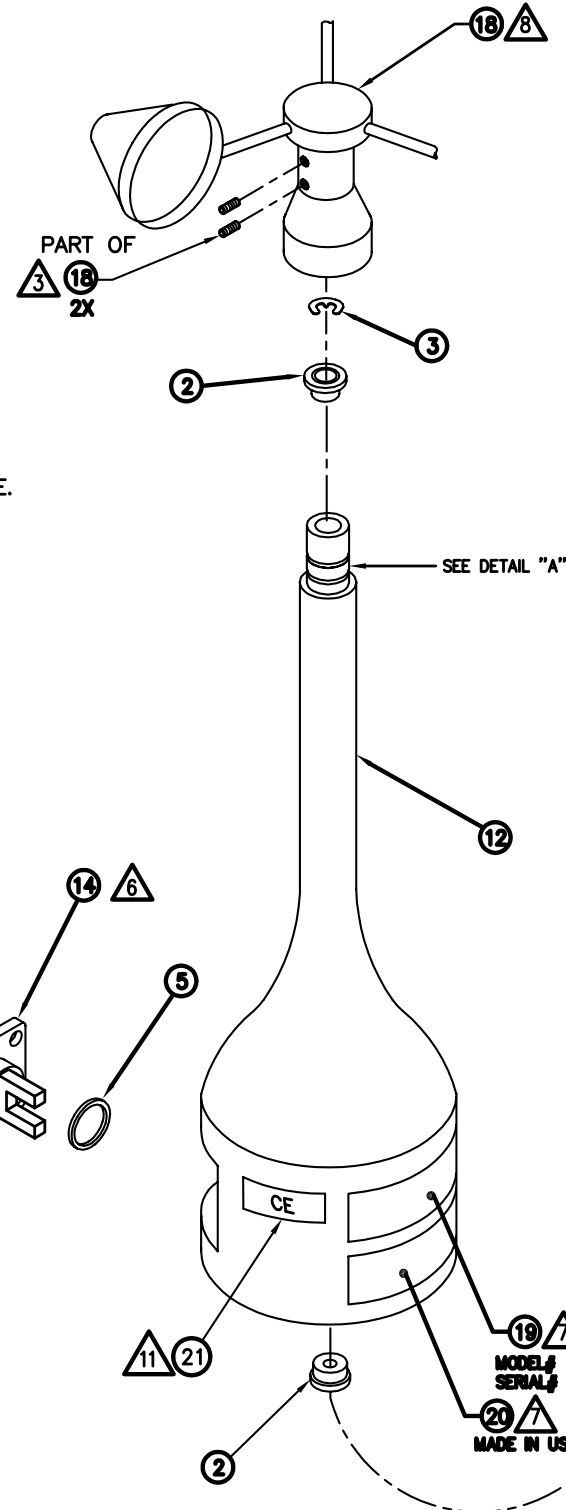

EXCEPT AS MAY OTHERWISE BE SPECIFIED BY CONTRACT, THIS DOCUMENT AND THE DATA DISCLOSED HEREIN AND HEREWITH, IS NOT TO BE USED, REPRODUCED OR DISCLOSED, IN WHOLE OR IN PART, TO ANYONE WITHOUT THE WRITTEN PERMISSION OF ADB SAFEGATE.

APPEND THE FOLLOWING DOCUMENTS WHEN CHANGING THIS DOCUMENT: 2030-001		UNLESS OTHERWISE SPECIFIED: DIMENSIONS ARE IN INCHES TOLERANCES XX=±.010 ANGLES ±1/2" XXX=±.005 FRACTIONS=±.02 DO NOT SCALE DRAWING		DRAWN BY: KOOYMAN 29JUL93		TITLE ASSEMBLY DRAWING, MICRO RESPONSE ANEMOMETER, MODEL 2030		ADB SAFEGATE
		MATERIAL SEE BILL OF MATERIALS		REVISED BY: P. KOOYMAN 24MAR03		DESIGN ENGINEER: J. CONNER 11-21-95		
		FINISH AS ISSUED		CHECKED BY:		PROJECT MANAGER:		D
		TREATMENT		APPROVALS		DATE		
				SCALE NONE		RELEASE DATE 9-82		SHEET 1 OF 1

DWG NO. 2030-003

REVISIONS			DWG NO. M403256-003	
REV	ECN	DESCRIPTION	DATE	APPROVED
A	4163	INITIAL RELEASE	9-8-93	SP
B	4805	CHANGE U-BOLTS	11/2/98	CSP
C	4981	ADD FOLDOVER TOWER VERSION SHT 2		
D	0626	CORRECTED P/NS SHEET 1	11-14-05	J.CONNER
E	1369	ADDED ICE RESISTANT HUB	3-10-09	J.CONNER

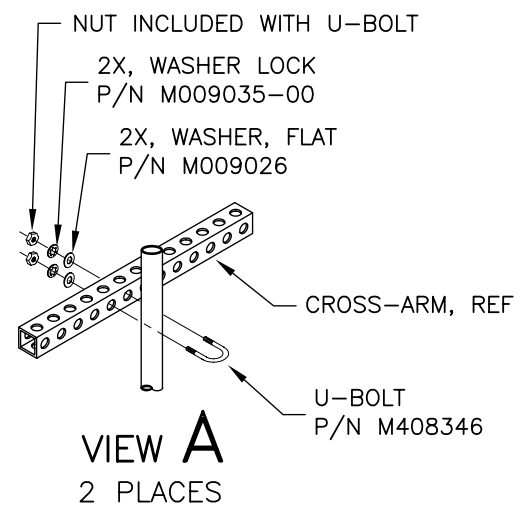
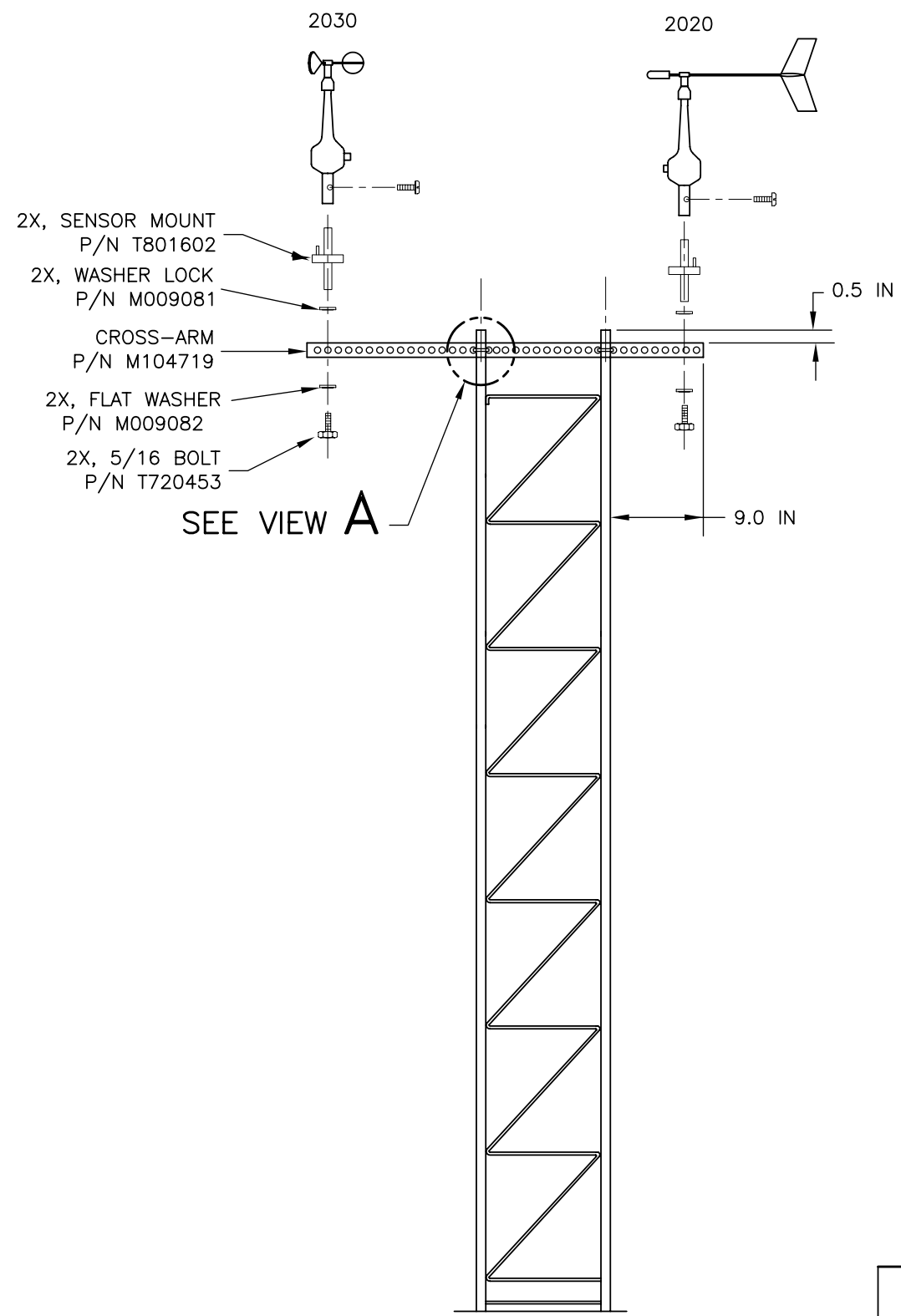

- 2X, SENSOR MOUNT
P/N T801602
- 2X, WASHER LOCK
P/N M009081
- CROSS-ARM
P/N M104719
- 2X, FLAT WASHER
P/N M009082
- 2X, 5/16 BOLT
P/N T720453

- NUT INCLUDED WITH U-BOLT
- 2X, WASHER LOCK
P/N M009035-00
- 2X, WASHER, FLAT
P/N M009026
- CROSS-ARM, REF
- U-BOLT
P/N M408346

2020/2030
AWOS MOUNTING
(STACKED TOWER)

EXCEPT AS MAY OTHERWISE BE SPECIFIED BY CONTRACT,
THIS DOCUMENT AND THE DATA DISCLOSED HEREIN
AND HERewith, IS NOT TO BE USED, REPRODUCED OR
DISCLOSED, IN WHOLE OR IN PART, TO ANYONE WITHOUT
THE WRITTEN PERMISSION OF ALL ADB SAFEGATE.

C	E	REV	REV STATUS
2	1	SHEET	OF SHEETS

UNLESS OTHERWISE SPECIFIED: DIMENSIONS ARE IN INCHES TOLERANCES XX=±.010 ANGLES ±1/2° XXX=±.005 FRACTIONS=±.02 DO NOT SCALE DRAWING	DRAWN BY: KOOYMAN	7SEP93	TITLE ASSEMBLY DRAWING, CROSSARM, 2020, 2030, AWOS	ADB SAFEGATE
	REVISIED BY: KOOYMAN	23SEPT03		
MATL SEE PARTS LIST	CHECKED BY:		SIZE C	DWG NO. M403256-003
FINISH AS ISSUED	DESIGN ENGINEER:			
TREATMENT	PROGRAM MANAGER: JM ANDERSON	8SEP93	SCALE NONE	RELEASE DATE 8SEP93
	APPROVALS	DATE	SHEET 1 OF 2	

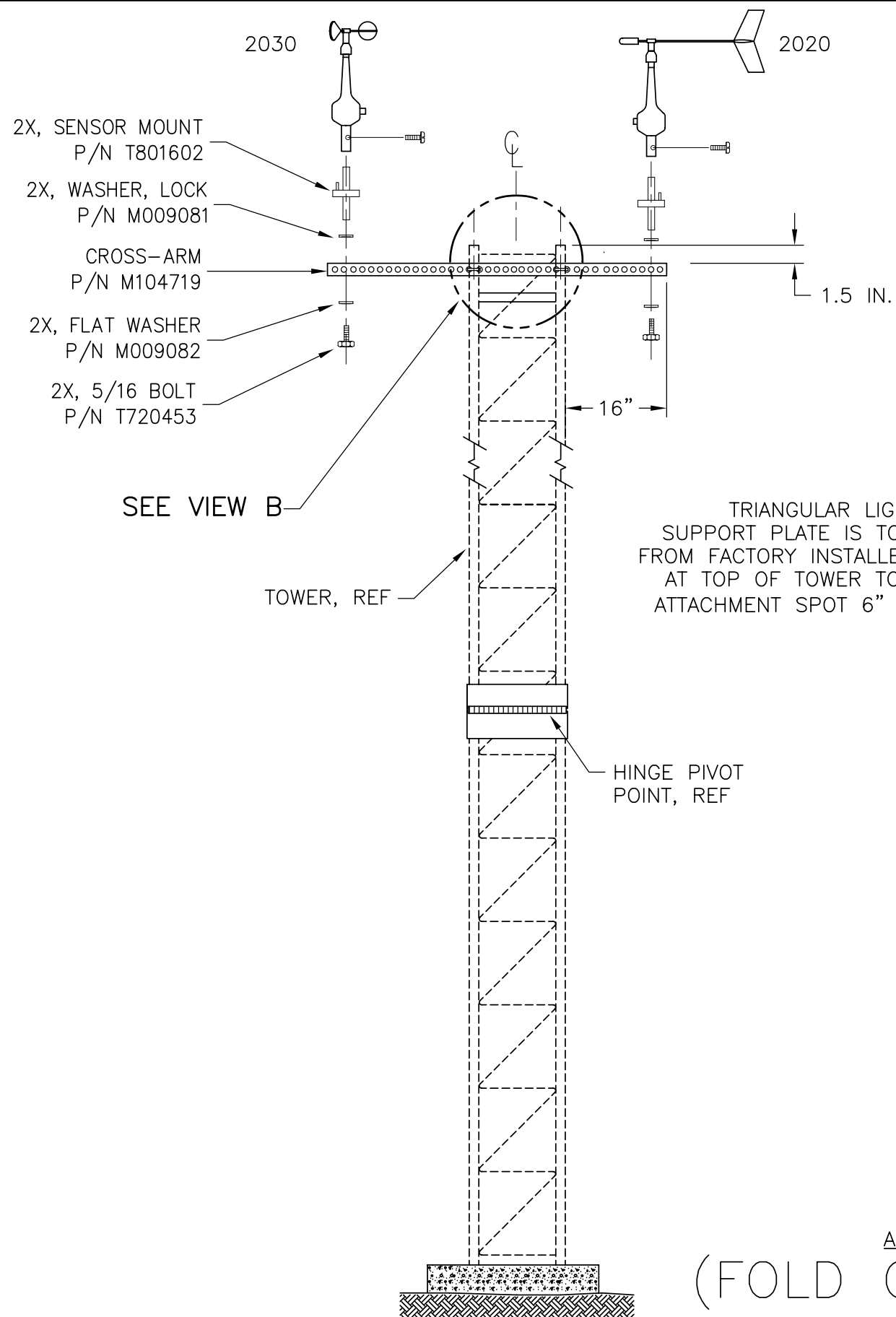

***NOTE:**
 TRIANGULAR LIGHTNING ROD
 SUPPORT PLATE IS TO BE MOVED
 FROM FACTORY INSTALLED LOCATION
 AT TOP OF TOWER TO THIS NEXT
 ATTACHMENT SPOT 6" BELOW TOP.

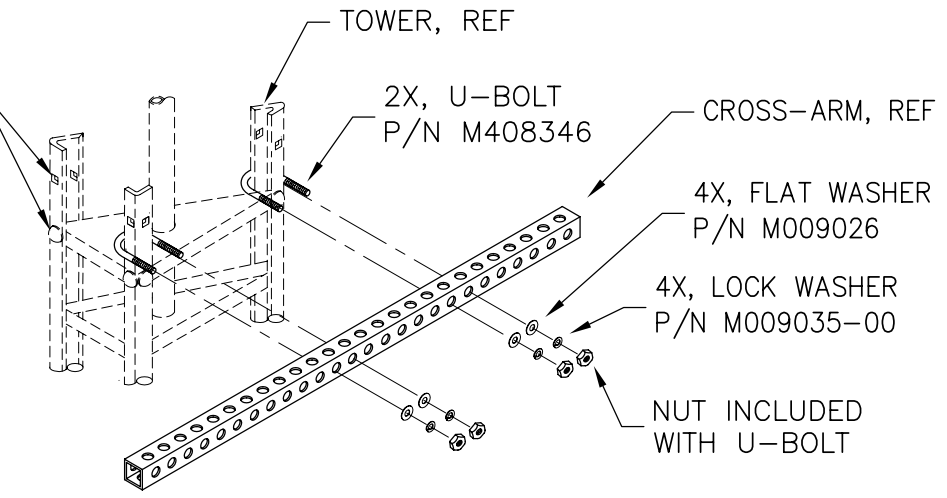

VIEW B

2020/2030
 AWOS MOUNTING
 (FOLD OVER TOWER)

EXCEPT AS MAY OTHERWISE BE SPECIFIED BY CONTRACT,
 THIS DOCUMENT AND THE DATA DISCLOSED HEREIN
 AND HEREWITH, IS NOT TO BE USED, REPRODUCED OR
 DISCLOSED, IN WHOLE OR IN PART, TO ANYONE WITHOUT
 THE WRITTEN PERMISSION OF ADB SAFEGATE.

SIZE	DWG NO.
C	M403256-003
SCALE	REV LTR
NONE	C
SHEET	2 OF 2

Optimizing Airside Operations From approach to take-off

SMARTER. BETTER. **NOW.**

**ADB
SAFEGATE**
www.adbsafegate.com