



Reliance EMIX-L LED Elevated Runway Edge Light

L-861, L-861E, & L861SE Medium Intensity, TP312 Threshold/
End, & MOS139 Medium & Low Intensity

User Manual

96A0477, Rev. v1.1.0, 2026-Jun-09

**ADB
SAFEGATE**

A.0 Disclaimer / Standard Warranty

CE certification

The equipment listed as CE certified means that the product complies with the essential requirements concerning safety and hygiene. The European directives that have been taken into consideration in the design are available on written request to ADB SAFEGATE.

ETL certification

The equipment listed as ETL certified means that the product complies with the essential requirements concerning safety and C22.2 No.180:13 (R2018) regulations. The CSA directives that have been taken into consideration in the design are available on written request to ADB SAFEGATE.

All Products Guarantee

ADB SAFEGATE will correct by repair or replacement per the applicable guarantee below, at its option, equipment or parts which fail because of mechanical, electrical or physical defects, provided that the goods have been properly handled and stored prior to installation, properly installed and properly operated after installation, and provided further that Buyer gives ADB SAFEGATE written notice of such defects after delivery of the goods to Buyer. Refer to the Safety section for more information on Material Handling Precautions and Storage precautions that must be followed.

ADB SAFEGATE reserves the right to examine goods upon which a claim is made. Said goods must be presented in the same condition as when the defect therein was discovered. ADB SAFEGATE further reserves the right to require the return of such goods to establish any claim.

ADB SAFEGATE's obligation under this guarantee is limited to making repair or replacement within a reasonable time after receipt of such written notice and does not include any other costs such as the cost of removal of defective part, installation of repaired product, labor or consequential damages of any kind, the exclusive remedy being to require such new parts to be furnished.

ADB SAFEGATE's liability under no circumstances will exceed the contract price of goods claimed to be defective. Any returns under this guarantee are to be on a transportation charges prepaid basis. For products not manufactured by, but sold by ADB SAFEGATE, warranty is limited to that extended by the original manufacturer. This is ADB SAFEGATE's sole guarantee and warranty with respect to the goods; there are no express warranties or warranties of fitness for any particular purpose or any implied warranties of fitness for any particular purpose or any implied warranties other than those made expressly herein. All such warranties being expressly disclaimed.

Standard Products Guarantee

Products manufactured by ADB SAFEGATE are guaranteed against mechanical, electrical, and physical defects (excluding lamps) which may occur during proper and normal use for a period of two years from the date of ex-works delivery, and are guaranteed to be merchantable and fit for the ordinary purposes for which such products are made.



Note

See your applicable sales agreement for a complete warranty description.

Replaced or repaired equipment under warranty falls into the warranty of the original delivery. No new warranty period is started for these replaced or repaired products.

FAA Certified products manufactured by ADB SAFEGATE

ADB SAFEGATE L858 Airfield Guidance Signs are warranted against mechanical and physical defects in design or manufacture for a period of 2 years from date of installation, per FAA AC 150/5345-44 (applicable edition).

ADB SAFEGATE LED products (with the exception of obstruction lighting) are warranted against electrical defects in design or manufacture of the LED or LED specific circuitry for a period of 4 years from date of installation, per FAA EB67 (applicable edition). These FAA certified constant current (series) powered LED products must be installed, interfaced and powered with and through products certified under the FAA Airfield Lighting Equipment Program (ALECP) to be included in this 4 (four) year warranty. This includes, but is not limited to, interface with products such as Base Cans, Isolation Transformers, Connectors, Wiring, and Constant Current Regulators.



Note

See your sales order contract for a complete warranty description.

Replaced or repaired equipment under warranty falls into the warranty of the original delivery. No new warranty period is started for these replaced or repaired products.

Liability



WARNING

Use of the equipment in ways other than described in the catalog leaflet and the manual may result in personal injury, death, or property and equipment damage. Use this equipment only as described in the manual.

ADB SAFEGATE cannot be held responsible for injuries or damages resulting from non-standard, unintended uses of its equipment. The equipment is designed and intended only for the purpose described in the manual. Uses not described in the manual are considered unintended uses and may result in serious personal injury, death or property damage.

Unintended uses, includes the following actions:

- Making changes to equipment that have not been recommended or described in this manual or using parts that are not genuine ADB SAFEGATE replacement parts or accessories.
- Failing to make sure that auxiliary equipment complies with approval agency requirements, local codes, and all applicable safety standards if not in contradiction with the general rules.
- Using materials or auxiliary equipment that are inappropriate or incompatible with your ADB SAFEGATE equipment.
- Allowing unskilled personnel to perform any task on or with the equipment.

Copyright Statement

This manual or parts thereof may not be reproduced, stored in a retrieval system, or transmitted, in any form or by any means, electronic, mechanical, photocopying, recording, nor otherwise, without the author's prior written consent.

This manual could contain technical inaccuracies or typographical errors. The author reserves the right to revise this manual from time to time in the contents thereof without obligation of the author to notify any person of such revision or change. Details and values given in this manual are average values and have been compiled with care. They are not binding, however, and the author disclaims any liability for damages or detriments suffered as a result of reliance on the information given herein or the use of products, processes or equipment to which this manual refers. No warranty is made that the use of the information or of the products, processes or equipment to which this manual refers will not infringe any third party's patents or rights. The information given does not release the buyer from making their own experiments and tests.

Table of Contents

1.0 Safety	1
1.1 Safety Messages.....	1
1.1.1 Introduction to Safety.....	2
1.1.2 Intended Use.....	2
1.1.3 Material Handling Precautions : Storage.....	3
1.1.4 Maintenance Safety.....	3
1.1.5 Material Handling Precautions, ESD.....	3
1.1.6 Arc Flash and Electric Shock Hazard.....	4
2.0 RELIANCE EMIX-L	5
2.1 About this manual.....	5
2.1.1 How to work with the manual.....	5
3.0 Runway Edge, Threshold and End, L-861(L), L-861E(L) and L-861SE(L)	7
4.0 Reliance EMIS-L Installation	11
4.1 Intended Use.....	11
4.2 Unpacking.....	11
4.3 Placement.....	11
4.3.1 Base Mounting.....	12
4.3.2 Light Base Mounting Procedure.....	14
4.4 Light Fixture Leveling.....	16
4.4.1 Align the Equipment.....	16
4.4.2 Final alignment check.....	17
5.0 Maintenance	19
5.1 Maintenance Safety.....	19
5.2 Maintenance Schedule.....	19
5.3 EMIS-L Lens Replacement.....	19
5.4 Troubleshooting.....	22
6.0 Reliance EMIX-L Parts	23
6.1 Ordering Codes.....	23
6.2 Parts Diagram.....	25
6.3 Reliance EMIX-L Spare Parts.....	31
6.4 Reliance EMIX-L LED Elevated Runway Edge Light Ordering Code.....	0
A.0 Support	33
A.1 ADB SAFEGATE Website.....	34
A.2 Recycling.....	35
A.2.1 Local Authority Recycling.....	35
A.2.2 ADB SAFEGATE Recycling.....	35

List of Figures

Figure 1: Base Mounting.....	14
Figure 2: Alignment Tool.....	17
Figure 3: The EMIS-L Optic Assembly.....	20
Figure 4: Split Lens Alignment	21
Figure 5: Power Supply Connection	22
Figure 6: EMIS-L Assembly.....	25
Figure 7: External Cordset (Digit 5 = 8) Configurations.....	27
Figure 8: Earthing (Digit 5 = 6) Configurations.....	27
Figure 9: Optic Assembly Parts Diagram.....	29
Figure 10: Cordsets	31

List of Tables

Table 1: L-861/L-861E Light Fixture Maintenance.....	19
Table 2: Troubleshooting Process.....	22
Table 3: TP312 Column Options.....	27
Table 4: Columns and Couplings.....	28
Table 5: Optic Assembly Combinations / Codes	30

1.0 Safety

Introduction to Safety

This section contains general safety instructions for installing and using ADB SAFEGATE equipment. Some safety instructions may not apply to the equipment in this manual. Task- and equipment-specific warnings are included in other sections of this manual where appropriate.

1.1 Safety Messages

HAZARD Icons used in this manual

For all HAZARD symbols in use, see the Safety section. All symbols must comply with ISO and ANSI standards.

Carefully read and observe all safety instructions in this manual, which alert you to safety hazards and conditions that may result in personal injury, death or property and equipment damage and are accompanied by the symbols shown below.

	<p>WARNING Failure to observe a warning may result in personal injury, death or equipment damage.</p>
	<p>DANGER – Risk of electrical shock or ARC FLASH Disconnect equipment from line voltage. Failure to observe this warning may result in personal injury, death, or equipment damage. ARC Flash may cause blindness, severe burns or death.</p>
	<p>WARNING – Wear personal protective equipment Failure to observe may result in serious injury.</p>
	<p>WARNING – Do not touch Failure to observe this warning may result in personal injury, death, or equipment damage.</p>
	<p>CAUTION Failure to observe a caution may result in equipment damage.</p>
	<p>ELECTROSTATIC SENSITIVE DEVICES This equipment may contain electrostatic devices.</p>

Qualified Personnel

	<p>Important Information The term qualified personnel is defined here as individuals who thoroughly understand the equipment and its safe operation, maintenance and repair. Qualified personnel are physically capable of performing the required tasks, familiar with all relevant safety rules and regulations and have been trained to safely install, operate, maintain and repair the equipment. It is the responsibility of the company operating this equipment to ensure that its personnel meet these requirements. Always use required personal protective equipment (PPE) and follow safe electrical work practice.</p>
--	--

1.1.1 Introduction to Safety



CAUTION

Unsafe Equipment Use

This equipment may contain electrostatic devices, hazardous voltages and sharp edges on components

- Read installation instructions in their entirety before starting installation.
- Become familiar with the general safety instructions in this section of the manual before installing, operating, maintaining or repairing this equipment.
- Read and carefully follow the instructions throughout this manual for performing specific tasks and working with specific equipment.
- Make this manual available to personnel installing, operating, maintaining or repairing this equipment.
- Follow all applicable safety procedures required by your company, industry standards and government or other regulatory agencies.
- Install all electrical connections to local code.
- Use only electrical wire of sufficient gauge and insulation to handle the rated current demand. All wiring must meet local codes.
- Route electrical wiring along a protected path. Make sure they will not be damaged by moving equipment.
- Protect components from damage, wear, and harsh environment conditions.
- Allow ample room for maintenance, panel accessibility, and cover removal.
- Protect equipment with safety devices as specified by applicable safety regulations
- If safety devices must be removed for installation, install them immediately after the work is completed and check them for proper functioning prior to returning power to the circuit.

Failure to follow these instructions can result in serious injury, death or equipment damage

Additional Reference Materials



Important Information

- IEC – International Standards and Conformity Assessment for all electrical, electronic and related technologies.
- IEC 60364 – Electrical Installations in Buildings.
- CSA – C22.2 No.180:13 (R2018), series isolating transformers for airport lighting.
- FAA Advisory: AC 150/5340-26 (current edition), Maintenance of Airport Visual Aid Facilities.
- Maintenance personnel must refer to the maintenance procedure described in the ICAO Airport Services Manual, Part 9.
- ANSI/NFPA 79, Electrical Standards for Metalworking Machine Tools.
- National and local electrical codes and standards.

1.1.2 Intended Use



CAUTION

Use this equipment as intended by the manufacturer

This equipment is designed to perform a specific function, do not use this equipment for other purposes

- Using this equipment in ways other than described in this manual may result in personal injury, death or property and equipment damage. Use this equipment only as described in this manual.

Failure to follow this instruction can result in serious injury or equipment damage

1.1.3 Material Handling Precautions : Storage



CAUTION

Improper Storage

Store this equipment properly

- If equipment is to be stored prior to installation, it must be protected from the weather and kept free of condensation and dust.

Failure to follow this instruction can result in equipment damage

1.1.4 Maintenance Safety



DANGER

ELECTRIC SHOCK HAZARD

THIS EQUIPMENT MAY CONTAIN ELECTROSTATIC DEVICES

- DO NOT OPERATE A SYSTEM THAT CONTAINS MALFUNCTIONING COMPONENTS. IF A COMPONENT MALFUNCTIONS, TURN THE SYSTEM OFF IMMEDIATELY.
- DISCONNECT AND LOCK OUT ELECTRICAL POWER.
- ALLOW ONLY QUALIFIED PERSONNEL TO MAKE REPAIRS OR REPLACE MALFUNCTIONING COMPONENTS ACCORDING TO INSTRUCTIONS PROVIDED IN MANUAL.

FAILURE TO FOLLOW THESE INSTRUCTIONS CAN RESULT IN DEATH OR EQUIPMENT DAMAGE

1.1.5 Material Handling Precautions, ESD



CAUTION

Electrostatic Sensitive Devices

This equipment may contain electrostatic devices

- Protect from electrostatic discharge.
- Electronic modules and components should be touched only when this is unavoidable e.g. soldering, replacement.
- Before touching any component of the cabinet you shall bring your body to the same potential as the cabinet by touching a conductive earthed part of the cabinet.
- Electronic modules or components must not be brought in contact with highly insulating materials such as plastic sheets, synthetic fiber clothing. They must be laid down on conductive surfaces.
- The tip of the soldering iron must be grounded.
- Electronic modules and components must be stored and transported in conductive packing.

Failure to follow this instruction can result in equipment damage

1.1.6 Arc Flash and Electric Shock Hazard



DANGER

SERIES CIRCUITS HAVE HAZARDOUS VOLTAGES

THIS EQUIPMENT PRODUCES HIGH VOLTAGES TO MAINTAIN THE SPECIFIED CURRENT - DO NOT DISCONNECT WHILE ENERGIZED.

- ALLOW ONLY QUALIFIED PERSONNEL TO PERFORM MAINTENANCE, TROUBLESHOOTING, AND REPAIR TASKS.
- ONLY PERSONS WHO ARE PROPERLY TRAINED AND FAMILIAR WITH ADB SAFEGATE EQUIPMENT ARE PERMITTED TO SERVICE THIS EQUIPMENT.
- AN OPEN AIRFIELD CURRENT CIRCUIT IS CAPABLE OF GENERATING >5000 VAC AND MAY APPEAR OFF TO A METER.
- NEVER UNPLUG A DEVICE FROM A CONSTANT CURRENT CIRCUIT WHILE IT IS OPERATING; ARC FLASH MAY RESULT.
- DISCONNECT AND LOCK OUT ELECTRICAL POWER.
- ALWAYS USE SAFETY DEVICES WHEN WORKING ON THIS EQUIPMENT.
- FOLLOW THE RECOMMENDED MAINTENANCE PROCEDURES IN THE PRODUCT MANUALS.
- DO NOT SERVICE OR ADJUST ANY EQUIPMENT UNLESS ANOTHER PERSON TRAINED IN FIRST AID AND CPR IS PRESENT.
- CONNECT ALL DISCONNECTED EQUIPMENT GROUND CABLES AND WIRES AFTER SERVICING EQUIPMENT. GROUND ALL CONDUCTIVE EQUIPMENT.
- USE ONLY APPROVED ADB SAFEGATE REPLACEMENT PARTS. USING UNAPPROVED PARTS OR MAKING UNAPPROVED MODIFICATIONS TO EQUIPMENT MAY VOID AGENCY APPROVALS AND CREATE SAFETY HAZARDS.
- CHECK THE INTERLOCK SYSTEMS PERIODICALLY TO ENSURE THEIR EFFECTIVENESS.
- DO NOT ATTEMPT TO SERVICE ELECTRICAL EQUIPMENT IF STANDING WATER IS PRESENT. USE CAUTION WHEN SERVICING ELECTRICAL EQUIPMENT IN A HIGH-HUMIDITY ENVIRONMENT.
- USE TOOLS WITH INSULATED HANDLES WHEN WORKING WITH AIRFIELD ELECTRICAL EQUIPMENT.

FAILURE TO FOLLOW THESE INSTRUCTIONS CAN RESULT IN DEATH OR EQUIPMENT DAMAGE

2.0 RELIANCE EMIX-L

L-861(L), L-861E(L) & L861SE(L) LED Elevated Runway Edge Light, and MOS139 Medium and Low Intensity.



2.1 About this manual

The manual shows the information necessary to:

- Install and maintain the LED Elevated Runway Edge Light (EMIS-L).

2.1.1 How to work with the manual

1. Become familiar with the structure and content.
2. Carry out the actions completely and in the given sequence.

3.0 Runway Edge, Threshold and End, L-861(L), L-861E(L) and L-861SE(L)

Compliance with Standards

FAA:	L-861(L), L-861E(L) and L-861SE(L) AC 150/5345-46 (Current Edition) and the FAA EB No. 67. ETL Certified.
ICAO:	Annex 14, Vol. I (Current Edition)
T/C:	Transport Canada TP 312, para. 5.3.12.7 and Appendix 5B Table 5B-1
MOS:	Part 139, para. 9.10.6, 9.10.13, 9.10.19 and 9.10.22

Uses

FAA L-861(L)

- Runway edge
- Visual or non-precision IFR runways

FAA L-861E(L)

- Runway threshold/end
- Visual runways or non-precision IFR runways

FAA L-861SE(L)

- Runway threshold/end
- Non-precision IFR runways

ICAO and T/C

- ICAO non-precision approach; Runway edge, Threshold and End

MOS

- Low-intensity runway edge and threshold/end
- Medium-intensity runway edge and threshold/end
- Stopway

Features

- Average LED life of 56,000 hours under high-intensity conditions and more than 150,000 hours under typical operating conditions, resulting in significant reduction or even elimination of ongoing maintenance costs and periodic re-lamping expenses.
- Single-latch, stainless steel clamp allows easy removal and replacement of top cover and lens.
- A gasket is used between the lens and the top cover and also between the top and bottom fixture head assemblies to form a watertight seal.
- Light fixture with arctic option uses a thermostatically controlled heater to prevent ice and snow buildup from obscuring light output. Melts ice similar to traditional incandescent fixtures.
- Three screws allow a 4° leveling adjustment of the fixture after installation.
- Fixture comes standard with a 1.5-inch coupling, but is available with a 2-inch coupling and in alternative thread patterns.
- For additional features common to many of our elevated LED fixtures, see data sheet 3043.

Operating Conditions

Temperature:	-40°F to +131°F / -40°C to +55°C
Wind:	Withstands wind velocities up to 300 mph / 482 kph

Packaging

Assembled Fixtures	Dimensions of Cartons (H x W x D)		Indiv. Weight lb / kg
	Individual in / cm	15 per box in / cm	
14" OAH	20.5 × 6.5 × 6.5 /	19.5 × 23.5 × 15.75 /	5 lb /
	52 × 17 × 17	50 × 60 × 40	2.3 kg
24" OAH	31 × 6.5 × 6.5 /	29.5 × 23.5 × 15.7 /	6.25 lb /
	79 × 17 × 17	49.5 × 49.5 × 78.7	2.8 kg
30" OAH	6.5 × 6.5 × 37 /	19.5 × 19.5 × 37 /	7 lb /
	16.5 × 16.5 × 94	49.5 × 49.5 × 94	3.2 kg

Leveling Device

Ordering Code

For accurate aiming and leveling, it is recommended to have one leveling device per airfield.



44A7645

Reliance EMIX-L LED Elevated Runway Edge Light Ordering Code



Application

MI = Runway edge, medium intensity

Lens Type

S = Glass

Cable and Connector

2 = 1 plug (2 -pin)⁹

6 = 1 plug (2-pin) and separate earth ground wire⁹

8 = 1 plug (2 -pin), externally connected^{1,2}

Color - Side 1^{4,5,6}

W = White

Y = Yellow

R = Red

G = Green

N = None (Obscured)

Color - Side 2^{4,5,6}

W = White

Y = Yellow

R = Red

G = Green

N = None (Obscured)

Overall Fixture Height/Coupling

1 = 14 in (35.6 cm) with 1.5" coupling, 12 TPI

2 = 20 in (50.8 cm) with 1.5" coupling, 12 TPI

3 = 24 in (61.0 cm) with 1.5" coupling, 12 TPI

4 = 30 in (76.2 cm) with 1.5" coupling, 12 TPI

5 = 14 in (35.6 cm) with 2" coupling, 11.5 TPI

6 = 20 in (50.8 cm) with 2" coupling, 1.5 TPI

7 = 24 in (61.0 cm) with 2" coupling, 11.5 TPI

8 = 30 in (76.2 cm) with 2" coupling, 11.5 TPI

9 = 14 in (35.6 cm) with 2" coupling, 11 TP^{1,3}

A = 20 in (50.8 cm) with 2" coupling, 1 TP^{1,3}

B = 24 in (61.0 cm) with 2" coupling, 11 TP^{1,3}

C = 30 in (76.2 cm) with 2" coupling, 11 TP^{1,3}

D = 18 in (45.7 cm) with 1.5" coupling, 12 TPI

E = 18 in (45.7 cm) with 2" coupling, 11.5 TPI

H = 16 in (40.6 cm) with 1.5" coupling, 12 TPI

R = ICAO < 350mm OAH (2" coupling), 11.5 TPI^{1,3}

W = ICAO < 350mm OAH (2" coupling), 11 TPI^{1,3}

Power Supply

S = Current Driven, 50/60 Hz

Photometrics

0 = ICAO and FAA compliant

F = FAA compliant (L-861SE only)

C = Canada, TP 312-compliant¹

L = MOS 139 compliant (low intensity)^{1,8}

M = MOS 139 compliant (medium intensity)^{1,8}

Arctic Option

0 = Without arctic option

1 = With arctic option⁷

Ordering Code Notes

- ¹ Not ETL Certified.
- ² Cord set connected externally to column, not available if digit 9 is R or W.
- ³ Normally used in metric applications.
- ⁴ Color combinations not recognized by FAA: white/green, white/obscured, and yellow/obscured.
- ⁵ FAA color combinations are: red, red/green, obscured/green white/red, white/yellow, white/white, yellow/red, yellow/green and yellow/yellow.
- ⁶ MOS color combinations are white/white, red/white, red/obscured, red/green and obscured/green.
- ⁷ Arctic kit Not available for MOS 139.
- ⁸ MOS certified applications only available with overall height / fixture coupling options R or W).
- ⁹ If Digit 9 is R or W, digit 5 must be 2 or 6.

Power Supply

Medium-intensity runway fixtures should be operated on a 3-step series circuit. 6.6 A through an L-830 (for 60 Hz) or L-831 (for 50 Hz) isolation transformer. Light fixtures LED lights have been designed to work with any IEC- or FAA-compliant transformer up to 30/45 W without affecting performance or lifetime of the light or the transformer.

	Fixture Load	Isolation Transformer	Isol. XF Load	CCR Load
L-861(L)				
W/out heater	9.9 VA	10/15 W	11.6 VA	21.5VA
With heater	29.9 VA	30/45 W	9 VA	38.9 VA
L-861E(L) - Bidirectional				
W/out heater	5.7 VA	10/15 W	12.2 VA	17.9 VA
With heater	25.7 VA	30/45 W	9 VA	34.7 VA
L-861E(L) - Unidirectional				
W/out heater	4.8 VA	10/15 W	12.4 VA	17.2 VA
With heater	24.8 VA	30/45 W	9 VA	33.8 VA
L-861SE(L) - Bidirectional				
W/out heater	14.1 VA	10/15 W	12.1 VA	26.2 VA
With heater	34.1 VA	30/45 W	9 VA	43.1 VA
L-861SE(L) - Unidirectional				
W/out heater	10.6 VA	10/15 W	12.3 VA	22.8 VA
With heater	30.6 VA	30/45 W	9 VA	39.6 VA
MOS 139 - Low-intensity				
W/out heater	11.3 VA	10/15 W	6.7 VA	18.0 VA
MOS 139 - Medium-intensity				
W/out heater	22.5 VA	20/25 W	10.1 VA	32.6 VA

For more information about the product, including manuals, certifications, and photometric data, please see our Product Center on the ADB SAFEGATE website: www.adbsafegate.com.

4.0 Reliance EMIS-L Installation

This section provides instructions for installing the L-861, L-861E & L-861SE LED Elevated Runway Edge Light (EMIS-L) fixture. Refer to the airport project plans and specifications for the specific installation instructions.

4.1 Intended Use



CAUTION

Use this equipment as intended by the manufacturer

This equipment is designed to perform a specific function, do not use this equipment for other purposes

- Using this equipment in ways other than described in this manual may result in personal injury, death or property and equipment damage. Use this equipment only as described in this manual.

Failure to follow this instruction can result in serious injury or equipment damage

4.2 Unpacking

The equipment is shipped ready for installation. Handle equipment very carefully to prevent component damage. Unpack the carton upon receipt and check the contents and their condition. Note any exterior damage to the carton that might lead to detection of equipment damage.

If you note any damage to any equipment, file a claim with the carrier immediately. The carrier may need to inspect the equipment.

4.3 Placement

This subsection describes the placement of the EMIS-L light fixtures.

L-861 Light Fixture

Follow the guidelines below when placing the EMIS-L edge light fixture.

- The EMIS-L light fixture is normally positioned a maximum of 20 feet (6 m) off the edge of the hard surface of the runway, and in a straight line with all other light fixtures on the same side of the runway.
- The longitudinal spacing of the light fixtures should not exceed 200 feet (61 m).

L-861E Light Fixture

Follow the guidelines below when placing the L-861E threshold light fixture.

- The EMIS-L light fixture is normally positioned along the runway threshold.
- See the site plans for your airport for exact placement and spacing.

4.3.1 Base Mounting

L-861 light fixtures can be mounted on an L-867 base plate with a diameter and bolt-hole corresponding to either a 12-inch (304.8 mm) diameter L-867B base or a 16-inch (406.4 mm) diameter L-867D base plate per FAA AC 150/5345-46. The base plate is designed to receive a frangible coupling using a female thread. The standard coupling thread is 1-1/2 -12 UNF, optional thread is 2-11.5 NPT, and 2-11 TPI (ICAO application). A gasket is supplied with the base plate to form a watertight seal between the base plate and the L-867 light base per FAA AC 150/5345-46.



Note

Install the base according to FAA Advisory Circular AC 150/5340-30 and site plans.

The L-861 light fixtures can be mounted on an L-867 base mated with a base plate with a diameter and bolt-hole corresponding to either a 12-inch- or 16-inch- (304.8 or 406.4 mm) diameter L-867 base. The base plate is designed to receive a frangible coupling using a female thread. See [Figure 1](#).

Diagram Notes:

1. The L-861 is available with couplings to fit new design or existing baseplate with various thread designations: (1-1/2-12), (2-11 1/2), (2-11).
See the EMIL ordering codes or speak to your ADB Safegate representative.
2. Apply anti-seize compound to threads of frangible coupling when installing new or replacing existing L-861T.
3. Existing L-830 / L-831 30W/45W transformer can be used or a 100W isolation transformer may be substituted.

Figure 1: Base Mounting

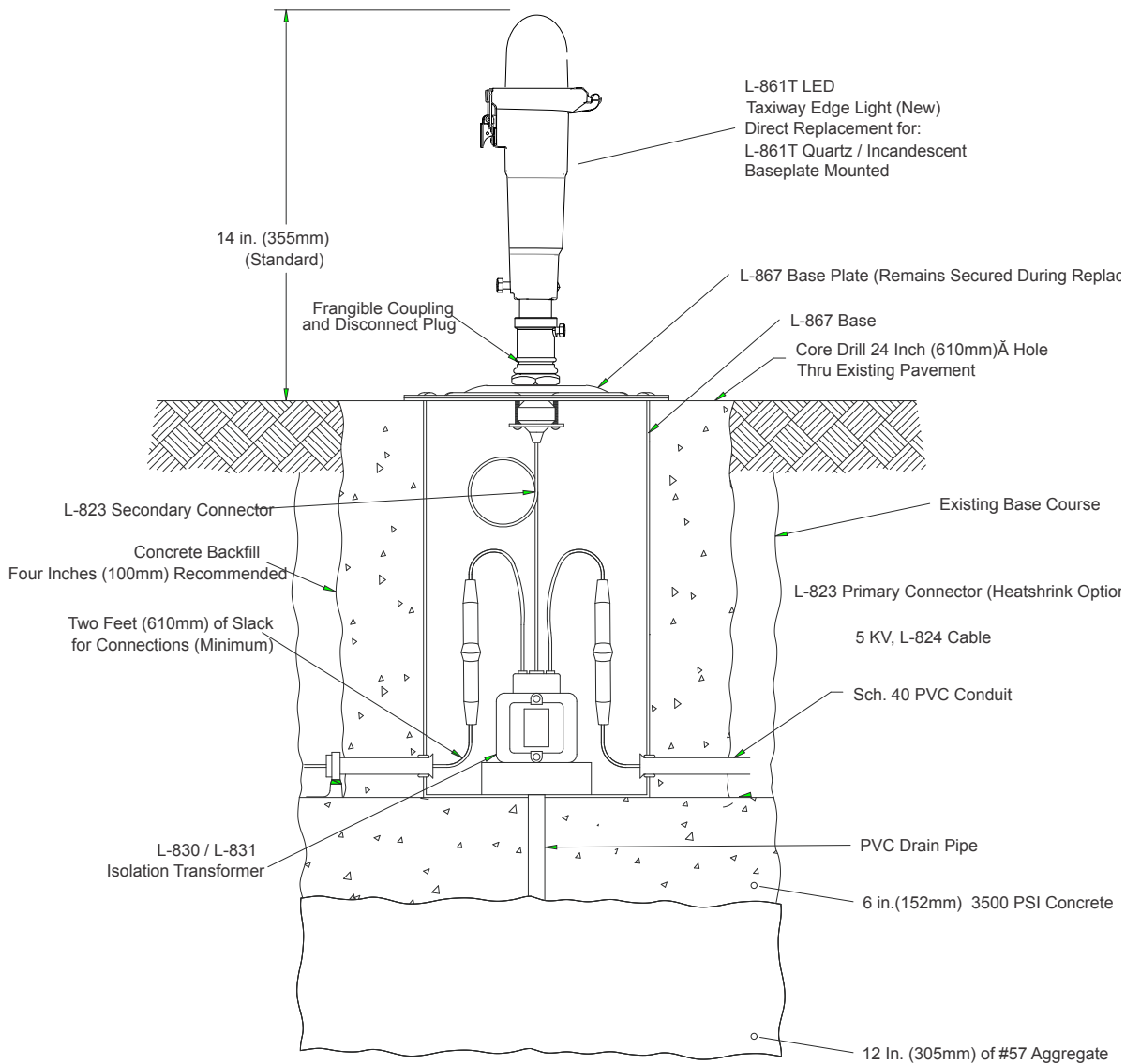

EXAMPLE OF BASE MOUNTED EMIX FIXTURE INSTALLATION
IN EXISTING SHOULDER SECTION

Installation Notes

1. Loosen set screw located on frangible coupling.
2. Back frangible coupling out of base plate or stake hub.
3. Unplug existing L-861 from L-823 connection.
4. Replace with L-861 LED, EMIX-L fixture.

4.3.2 Light Base Mounting Procedure

To install the base, perform the following procedure:

1. Install the L-867 base on undisturbed soil. If the soil is unsuitable, remove soil to an adequate depth and replace with compacted acceptable material.



Note

In closed duct systems, install in soil conditions with good drainage. Use light bases having a drain hole to prevent water accumulation.

2. Orient the cable entrance hubs of the light base in the proper direction according to site plans.
3. Level the light base so that the mounting flange surface is level in all directions.
4. With the base at the proper orientation and held at proper elevation, place approximately 4 inches (102 mm) of concrete backfill around the outside base.



Note

If the concrete backfill is omitted, the earth backfill must be compacted to maintain proper elevation and orientation of the base.

5. Slope the top of the concrete away from the flange portion of the base so the sloped outer edges of the concrete are at surface grade.
6. Hand screw the entire fixture onto the base plate.
Finish tightening the fixture by using a wrench on the flat areas of the frangible coupling.
7. Place the assembled base plate/fixture close to the base can.
8. Connect the fixture leads to the isolation transformer.
9. Bolt the base plate with the base plate gasket to the L-867 base using six 3/8-16 stainless steel bolts. Apply a drop of Loctite number 243 to each bolt thread, and use a torque wrench to torque bolts down to 100-110 inch-pounds (11.3 N•m).



Note

For TP312 Threshold/End light installation, see the airport specific drawings or consult your local airport authority for installation requirements.

4.4 Light Fixture Leveling



**EMix leveling/aiming device
44A7645**

Level the light fixture only after mounting the aiming device on the light base.

Depending on the position of the equipment, the reference mark may be another light in the same row or a stick installed for this purpose.

Usually, for runway edge lights another light of the same row is used. For threshold / runway end lights, a stick can be installed in the prolongation of the line of the threshold / runway end lights.

To level the light fixture, perform the following procedure:

1. Place the aiming device over the glassware assembly.
2. Slightly loosen the three hex screws at the bottom of the housing. Make certain that the alignment tool notch is centered on the EMIS raised alignment mark.



Note

There are 4 alignment notches so that the tool can be located at any 90 degree increment.

3. Tighten the three hex screws finger tight.
Depending on the side and direction one is working, set the azimuth in order to look in the direction of the reference mark.

4.4.1 Align the Equipment

1. Loosen the retaining bolt.
2. From the top down, look into the Aiming Device Eyepiece and turn the equipment until it aligns with the reference mark.
3. While maintaining the fixture in this position, tighten.
4. Check the level again.
5. Carefully tighten the hex screws of the support (gradually, going round) while keeping the light in the right position. Make sure the light is firmly fixed.

6. Check the Alignment again.



Note

In order to avoid repeating a possible mistake, it is advisable that the final check be made by another operator, or in a different order, than the original alignment.

Figure 2: Alignment Tool

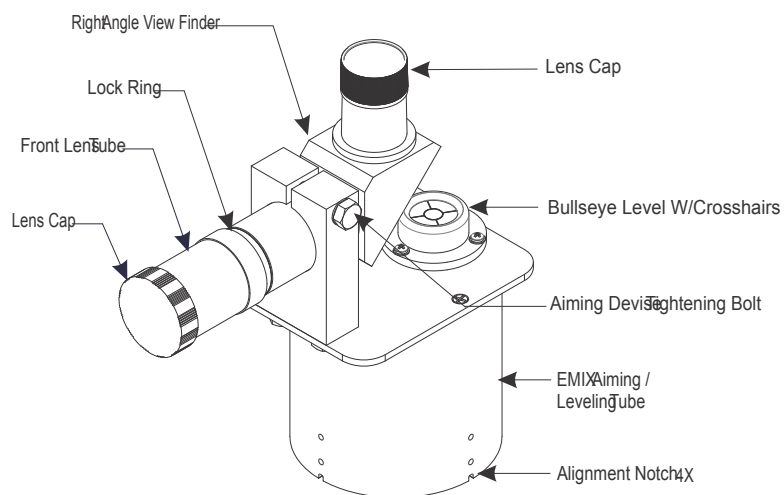

4.4.2 Final alignment check

1. From the top down, look into the Aiming Device Eyepiece and check that it aligns with the reference mark. If the alignment is not correct or if the equipment is not level, align or level the equipment.
2. Tighten all screws and nuts holding the light in place with the proper tools.

5.0 Maintenance

Reliance EMIS-L

5.1 Maintenance Safety



DANGER

ELECTRIC SHOCK HAZARD

THIS EQUIPMENT MAY CONTAIN ELECTROSTATIC DEVICES

- DO NOT OPERATE A SYSTEM THAT CONTAINS MALFUNCTIONING COMPONENTS. IF A COMPONENT MALFUNCTIONS, TURN THE SYSTEM OFF IMMEDIATELY.
- DISCONNECT AND LOCK OUT ELECTRICAL POWER.
- ALLOW ONLY QUALIFIED PERSONNEL TO MAKE REPAIRS OR REPLACE MALFUNCTIONING COMPONENTS ACCORDING TO INSTRUCTIONS PROVIDED IN MANUAL.

FAILURE TO FOLLOW THESE INSTRUCTIONS CAN RESULT IN DEATH OR EQUIPMENT DAMAGE

5.2 Maintenance Schedule

To keep the EMIS-L light fixtures operating efficiently, follow a preventive maintenance schedule. Refer to [Table 1](#). Refer to FAA AC 150/5340-26 for additional recommendations.

Table 1: L-861/L-861E Light Fixture Maintenance

Interval	Maintenance Task	Action
Daily	Inspect for outages Check cleanliness of lenses	Repair as necessary Clean as necessary
Weekly	Check for vegetation.	Remove vegetation. Use weed killer.
Monthly	Check for misaligned fixture.	Straighten, level, and align.
Annually	Check for improper ground elevation. Check for improper light elevation. Check for corrosion present or paint loose or chipped. Check gaskets/seal for leakage	Grade so frangible point is approximately 1 inch (25 mm) above ground elevation. Maintain same elevation for all light fixtures. Scrape and repaint. Touch up paint as necessary. Replace gasket/seal if torn or damaged
Unscheduled	Make prediction of heavy snowfall, if necessary.	Use red flags or sticks to mark the location of fixtures to facilitate snow removal and lessen the chance of damage to fixtures by snow removal equipment.

5.3 EMIS-L Lens Replacement

Before starting, read the entire procedure. A #2 Phillips screw driver and, a Sharpie or equivalent is required.

1. Follow your airport's established lockout-tagout procedures to turn off the circuit of the fixture to be repaired.

2. Open the EMIS fixture by pulling the latch open. Lift the top open from the latch.

Figure 3: The EMIS-L Optic Assembly

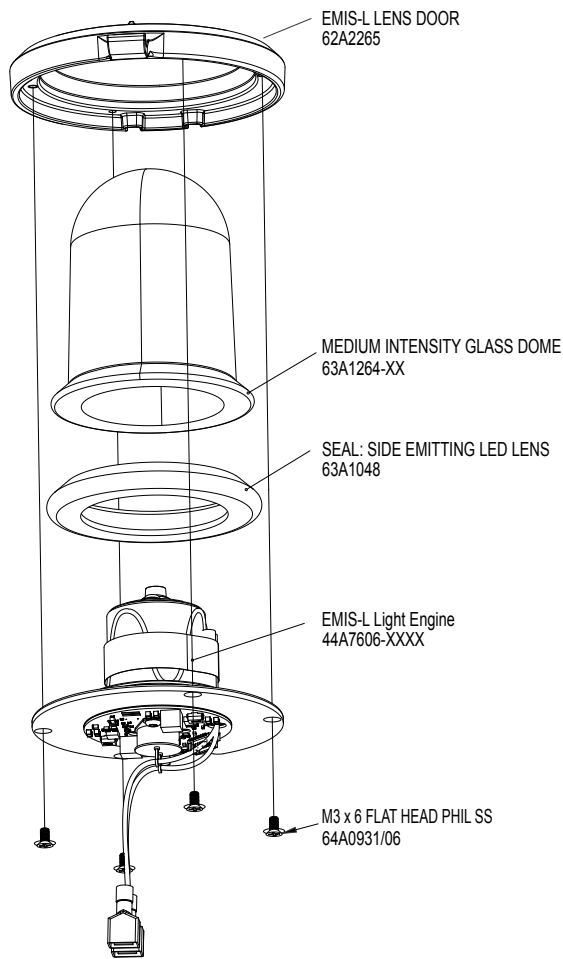

Note

See [Figure 9](#).

3. Disconnect the heaters from the PCB if used.
4. Unhinge the top assembly and place on a non-abrasive surface.
5. Remove the 2 screws retaining the LED assembly, see [Figure 3](#).
6. Remove the gasket protecting the lens base.
Replace the gasket if damaged.
7. Press firmly on the lens top to dislodge the lens and the lens seal gasket.

8. Remove the lens from the lens seal gasket.
Replace the gasket if damaged.

Figure 4: Split Lens Alignment

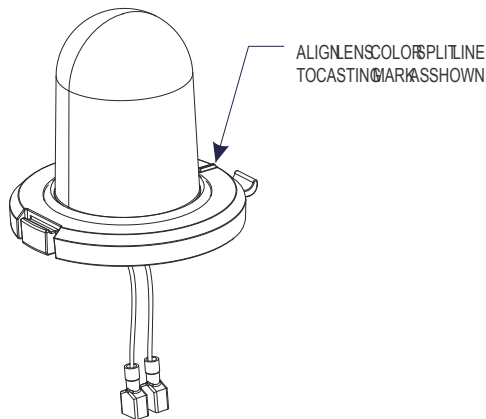

9. Place the new lens into the lens seal gasket.
10. Align the colors per the Aiming Profile as shown in [Figure 4](#).
11. Press this assembly into the top cover until it is seated correctly, see [Figure 4](#).
12. Install the gasket protecting the lens base.
13. Install the 2 screws retaining the PCB/top cover assembly, see [Figure 3](#).
14. Connect the heaters to the LED PCB if used.
15. Close the unit.
16. Connect the hinge of the top assembly.

17. Close the latch firmly.
Turn on the circuit of the fixture that was repaired after all other work is complete.

Figure 5: Power Supply Connection

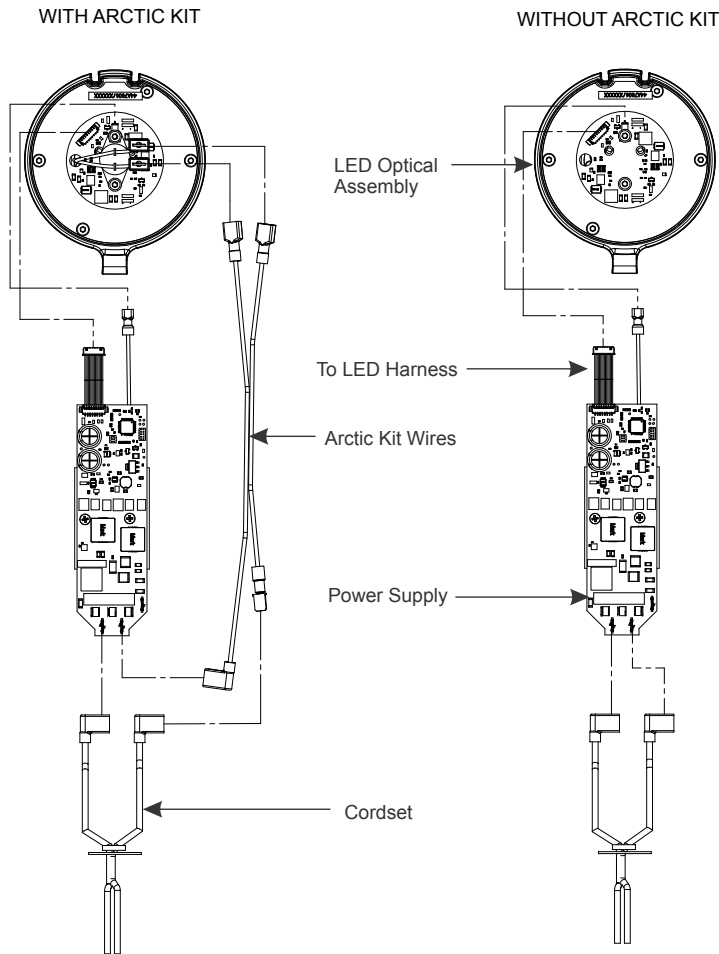

5.4 Troubleshooting

This section contains troubleshooting information for the RELIANCE EMIS-L light fixtures. This information covers only the most common problems that you may encounter. If you cannot solve the problem with the information given here, contact your local ADB Safegate representative for help.

Refer below for troubleshooting procedures for the L-861, L-861E, L861SE LED Elevated Runway Edge Light (EMIS-L).

Table 2: Troubleshooting Process

Problem	Possible Cause	Corrective Action
1. LED will not turn on.	Defective LED	Replace LED Assembly.
	Loose connection(s)	Tighten wires.
	Transformer on series circuit bad	Replace the transformer.
2. Moisture present in fixture.	Broken lens or faulty gasket.	Open up and dry light fixture. Inspect lens for cracks. Replace gasket.
		Replace the LED assembly and any damaged parts.
3. Ice forming on lens.	Defective or missing arctic kit	Remove the glassware assembly and check to see if heating element is installed. If missing or defective install new arctic kit. See Spare Parts List in the catalog sheet.

6.0 Reliance EMIX-L Parts

6.1 Ordering Codes

Reliance EMIX-L LED Elevated Runway Edge Light Ordering Code

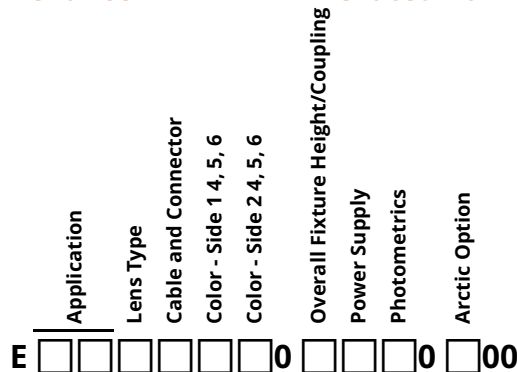

Application

MI = Runway edge, medium intensity

Lens Type

S = Glass

Cable and Connector

2 = 1 plug (2-pin)⁹

6 = 1 plug (2-pin) and separate earth ground wire⁹

8 = 1 plug (2-pin), externally connected^{1,2}

Color - Side 1^{4, 5, 6}

W = White

Y = Yellow

R = Red

G = Green

N = None (Obscured)

Color - Side 2^{4, 5, 6}

W = White

Y = Yellow

R = Red

G = Green

N = None (Obscured)

Ordering Code Notes

¹ Not ETL Certified.

² Cord set connected externally to column, not available if digit 9 is R or W.

³ Normally used in metric applications.

⁴ Color combinations not recognized by FAA: white/green, white/obscured, and yellow/obscured.

⁵ FAA color combinations are: red, red/green, obscured/green white/red, white/yellow, white/white, yellow/red, yellow/green and yellow/yellow.

⁶ MOS color combinations are white/white, red/white, red/obscured, red/green and obscured/green.

⁷ Arctic kit Not available for MOS 139.

⁸ MOS certified applications only available with overall height / fixture coupling options R or W).

⁹ If Digit 9 is R or W, digit 5 must be 2 or 6.

Overall Fixture Height/Coupling

1 = 14 in (35.6 cm) with 1.5" coupling, 12 TPI

2 = 20 in (50.8 cm) with 1.5" coupling, 12 TPI

3 = 24 in (61.0 cm) with 1.5" coupling, 12 TPI

4 = 30 in (76.2 cm) with 1.5" coupling, 12 TPI

5 = 14 in (35.6 cm) with 2" coupling, 11.5 TPI

6 = 20 in (50.8 cm) with 2" coupling, 11.5 TPI

7 = 24 in (61.0 cm) with 2" coupling, 11.5 TPI

8 = 30 in (76.2 cm) with 2" coupling, 11.5 TPI

9 = 14 in (35.6 cm) with 2" coupling, 11 TP^{1,3}

A = 20 in (50.8 cm) with 2" coupling, 1 TP^{1,3}

B = 24 in (61.0 cm) with 2" coupling, 11 TP^{1,3}

C = 30 in (76.2 cm) with 2" coupling, 11 TP^{1,3}

D = 18 in (45.7 cm) with 1.5" coupling, 12 TPI

E = 18 in (45.7 cm) with 2" coupling, 11.5 TPI

H = 16 in (40.6 cm) with 1.5" coupling, 12 TPI

R = ICAO < 350mm OAH (2" coupling), 11.5 TPI^{1,3}

W = ICAO < 350mm OAH (2" coupling), 11 TPI^{1,3}

Power Supply

S = Current Driven, 50/60 Hz

Photometrics

0 = ICAO and FAA compliant

F = FAA compliant (L-861SE only)

C = Canada, TP 312-compliant¹

L = MOS 139 compliant (low intensity)^{1,8}

M = MOS 139 compliant (medium intensity)^{1,8}

Arctic Option

0 = Without arctic option

1 = With arctic option⁷

EMISL Leveling Device
Ordering Code

For accurate aiming and leveling, it is recommended to have one leveling device per airfield.



44A7645

6.2 Parts Diagram

Figure 6: EMIS-L Assembly

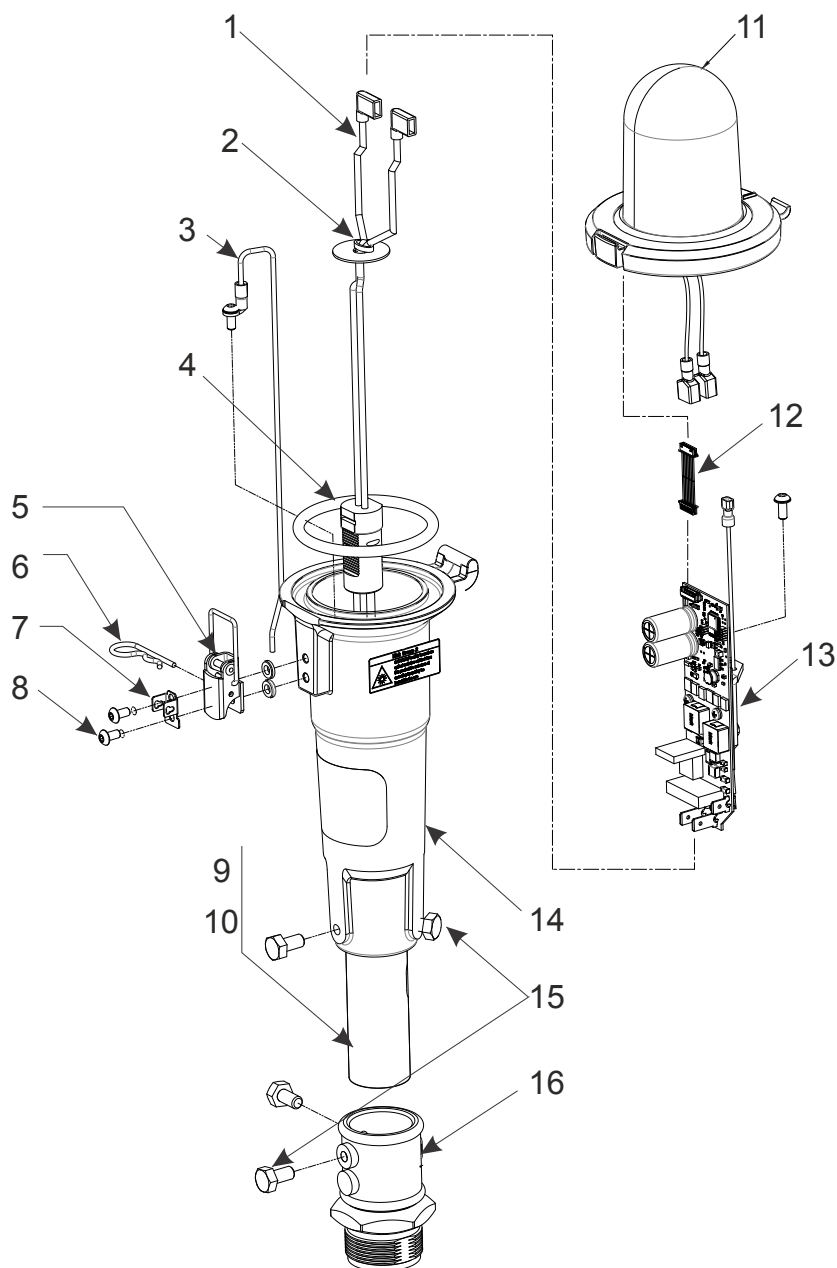

Label	Part Name	Code	Qty
1	L823 CORDSET, STYLE 6, LED ELEVATED	SP00089-000-01	5
2	FLAT WASHER SS 1.088 OD X .306 ID X .038 THK	SP00092-000-01	50
3	EMIS - EARTHING WIRE LEAD ASSEMBLY	SP00085-000-01	5
4	EMIS O-RING SEAL	SP00080-000-01	5
5,6,7,8*	EMIS Latch & Pin	SP00082-000-01	5
6	Stainless Steel Reusable Cotter Pin	SP00083-000-01	50

Label	Part Name	Code	Qty
9	COLUMN ELEVATED LIGHT	SP00095-XXX-01	1
10	COLUMN ELEVATED LIGHT-SLOTTED	SP00095-XXC-01	1
11	EMIS OPTIC ASSEMBLY LED ELEVATED RUNWAY EDGE LIGHT	SP.44A7654/XXXXX	
12	HARNESS ASSY EMIL PWR SUPPLY TO LED DRIVER	SP00079-000-01	5
13	EMIX POWER SUPPLY ASSEMBLY	SP00084-000-01	1
14	CASTING, LED ELEVATED LIGHT HOUSING EMIL	SP00081-000-01	1
15	1/4-20 X 1/2 HX HD	SP00093-000-01	100
16	Frangible Coupling 1.5" to 1", 12 TPI	SP.011347	1
16	Frangible coupling 2" to 1", 11 TPI	SP.011335	1
16	Frangible coupling 2" to 1", 11 TPI	SP00094-000-01	1
16	Frangible coupling 2" to 1", 11 TPI, ICAO <350mm	SP.ASMC00094-001	1
16	Frangible coupling 2" to 1", 11.5 TPI, ICAO <350mm	SP.ASMC00094-002	1



Note

Secure screws (8) with Loctite 262

For TP312 column options, see [Figure 7](#).

Table 3: TP312 Column Options

Figure 7: External Cordset (Digit 5 = 8) Configurations

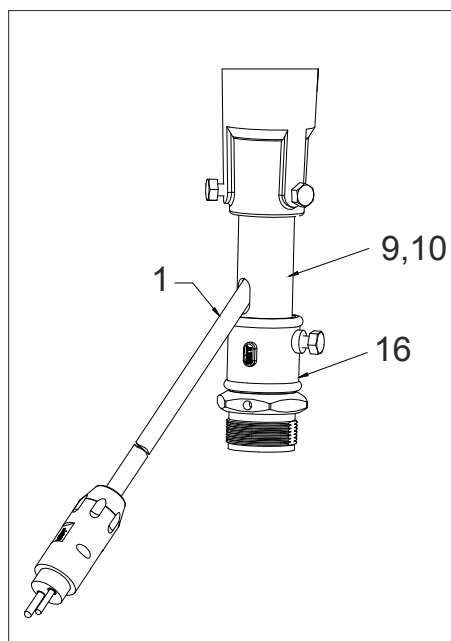
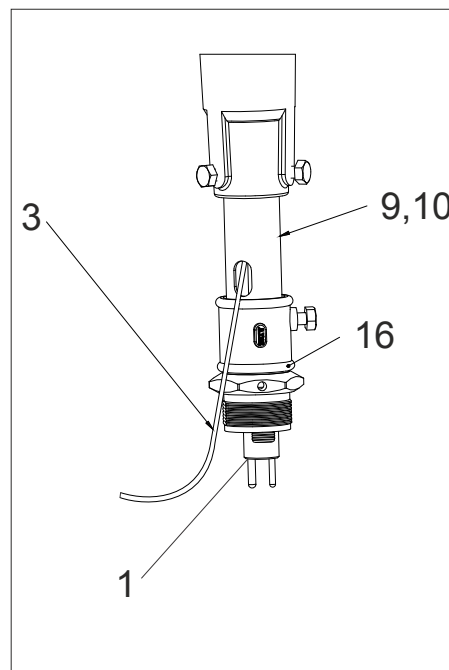

Figure 8: Earthing (Digit 5 = 6) Configurations



Label	Part Name	Code	Qty
1	L823 cordset, style6, LED elevated	SP00086-XXX-01	5
1	L-823 cordset, style 1, exits through slot in column on external cordset (DIGIT 5 = 8) configurations	SP00089-000-01	1
10	Column elevated light - slotted	SP00095-XXC-01	1
16	Frangible coupling 2" to 1", 11 TPI	SP.011347	1
16	Coupling frangible reduc 2"-1"G2-ISO22 11.5 TPI	SP.011335	1
16	Frangible coupling 2" to 1", 11 TPI	SP00094-000-01	1
3	EMIS Earthing wire lead assembly column on EARTHING exits through slot in (DIGIT 5 = 6) configurations	SP00085-000-01	5

Table 4: Columns and Couplings

TABLE B (DIGIT 9 & DIGIT 5)								
Digit 9 OAH/ Coupling	DIGIT 5 = 2 OR 6				DIGIT 5 = 8			Frangible Coupling
	Digit 5 = 2 SP00095-XXX-01 Column	Digit 5 = 6 SP00095-XXC-01 C Column	73A0136/31 Cut Length "Dim X" .25 IN [6.4 mm]		Column SP00095-XXX-01	73A0107/37 Cut Length "Dim X" .25 IN [6.4 mm]		
R	N/A	N/A	9.25 IN	235 mm	N/A	N/A	N/A	SP.ASMC00094-002
W	N/A	N/A	9.25 IN	235 mm	N/A	N/A	N/A	SP.ASMC00094-001
1	030	03C	9.25 IN	235 mm		17.88 IN	454.2 mm	SP.011347
2	270	27C	15.25 IN	387.4 mm		23.88 IN	606.6 mm	
3	130	13C	19.38 IN	492.3 mm		28.00 IN	711.2 mm	
4	190	19C	25.38 IN	644.7 mm		33.12 IN	841.3 mm	
5	030	03C	9.25 IN	235 mm	03C	17.88 IN	454.2 mm	SP.011335
6	270	27C	15.25 IN	387.4 mm		23.88 IN	606.6 mm	
7	130	13C	19.38 IN	492.3 mm	13C	28.00 IN	711.2 mm	
8	190	19C	25.38 IN	644.7 mm	19C	33.12 IN	841.3 mm	
9	030	03C	9.25 IN	235 mm		17.88 IN	454.2 mm	SP00094-000-01
A	270	27C	15.25 IN	387.4 mm		23.88 IN	606.6 mm	
B	130	13C	19.38 IN	492.3 mm		28.00 IN	711.2 mm	
C	190	19C	25.38 IN	644.7 mm		33.12 IN	841.3 mm	
D	790	79C	14.00 IN	355.6 mm		22.38 IN	568.5 mm	SP.011347
E	790	79C	14.00 IN	355.6 mm		22.38 IN	568.5 mm	SP.011335
F	790	79C	14.00 IN	355.6 mm		22.38 IN	568.5 mm	SP00094-000-01
G	030	03C	9.25 IN	235 mm	03C	17.88 IN	454.2 mm	-

Figure 9: Optic Assembly Parts Diagram

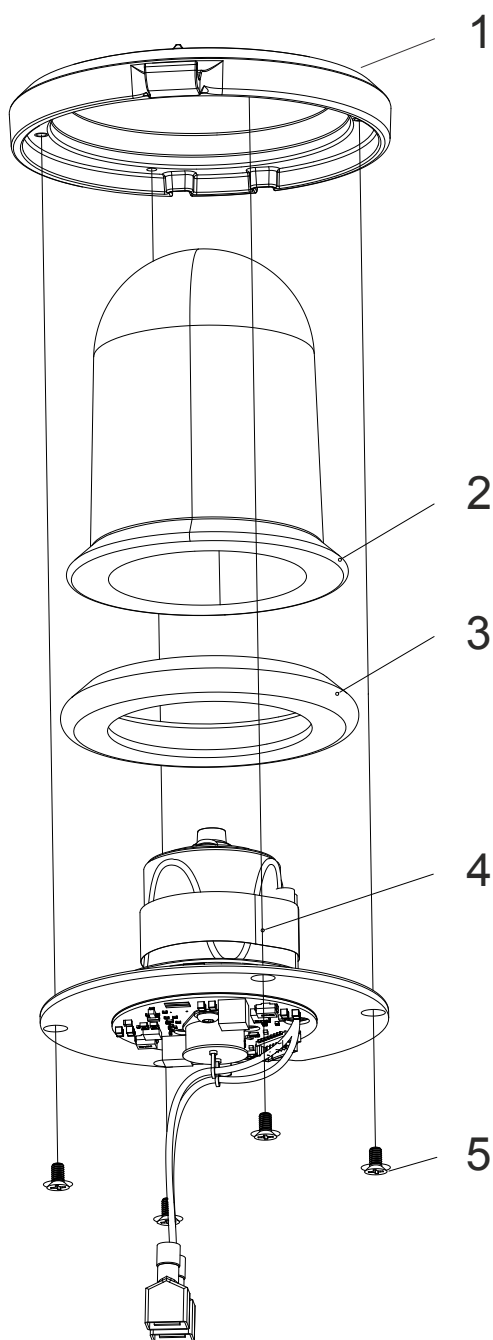

Label	Part Name	Code	Qty
1	EMIS-L LENS DOOR	SP00076-000-01	1
2	GLASS DOME	SP.63A1264/XX	1
3	SEAL: SIDE EMITTING LED LENS	SP.631048	5
4	EMIS-L Light Engine	SP.44A7606/X	1
5	M3 x 6 FLAT HEAD PHIL SS	SP00078-000-01	100

Table 5: Optic Assembly Combinations / Codes

		Using Assembly	Config.	Color		Glass Dome	Light Engine
EMIX Digit 11	Type	EMISX XX	SP.44A7654/ XXXXX	SIDE 1	SIDE 2	SP.63A1264/ XX	SP.44A7606/ XXXX
0	L-861	WW	1WWX0	WHT	WHT	CC	11XX0
		WY	1WYX0	WHT	YEL	CY	
		WR	1WRX0	WHT	RED	CD	
		WO	1WOX0	WHT	OBS	CO	
		YY	1YYX0	YEL	YEL	YY	
		YR	1YRX0	YEL	RED	YD	
		YO	1YOX0	YEL	OBS	YO	
		YG	1YGX0	YEL	GRN	YG	
	WG	1WGX0	WHT	GRN	CG	12X0	
	L-861E	RR	ERRX0	RED	RED	RR	E2X0
RG		ERGX0	RED	GRN	RG	E1X0	
OR		EORX0	OBS	RED	RO	E4X0	
OG		EOGX0	OBS	GRN	GO	E3X0	
F	L-861SE	RG	SRGX0	RED	GRN	RG	S2X0
		OG	SOGX0	OBS	GRN	GO	S1X0
I	ICAO TPL	BB	TBBX0	BLU	BLU	BB	T1X0
C	TP312	RR	CRRX0	RED	RED	RR	C1X0
		RG	CRGX0	RED	GRN	RG	C2X0
		RO	CROX0	RED	OBS	RO	C3X0
		GO	CGOX0	GRN	OBS	GO	C4X0
		WR	CWRX0	WHT	RED	CR	C5X0
		WG	CWGX0	WHT	GRN	CG	C6X0
		YR	CYRX0	YEL	RED	YR	C7X0
		YG	CYGX0	YEL	GRN	YG	C8X0
M	MOS 139 Non-Arctic Only	WW	MWW00	WHT	WHT	CC	M100C
		RW	MRW00	RED	WHT		M200C
		RO	MRO00	RED	OBS		M300C
		RG	MRG00	RED	GRN		M400C
		OG	MOG00	OBS	GRN		M500C
L	MOS 139 Low Intensity Non-Arctic Only	WW	LWW00	WHT	WHT	CC	M600C
		RW	LRW00	RED	WHT		M700C
		RO	LRO00	RED	OBS		M800C
		RG	LRG00	RED	GRN		M900C
		OG	LOG00	OBS	GRN		M000C



Note

Note that the digit before the last 0 refers to the arctic kit option, where 1 = With Arctic Kit and 0 = Without Arctic Kit

6.3 Reliance EMIX-L Spare Parts

Figure 10: Cordsets

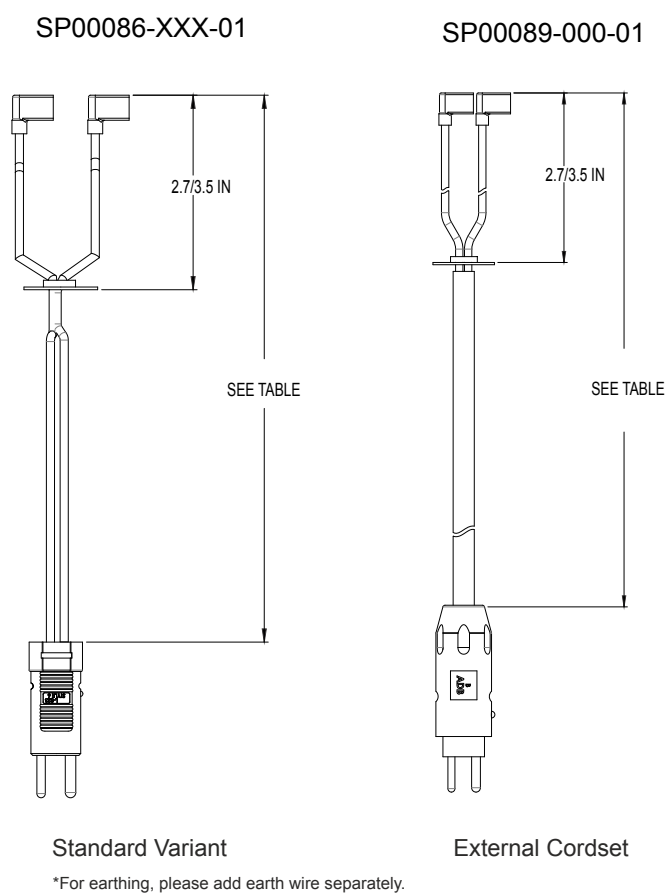

SP00086-XXX-01 Standard Variant		
OAH	Configuration 73A0136/31 Cut Length	
/14 or /14"	140	9.25
/18 or /18"	180	14
/20 or /20"	200	15.25
/24 or /24"	240	19.38
/30 or /30"	300	25.38
SP00089-000-01 External Cordset Variant (16AWG style 1, 31" unterminated)		

Appendix A: Support

Our experienced engineers are available for support and service at all times, 24 hour/7 days a week. They are part of a dynamic organization making sure the entire ADB SAFEGATE is committed to minimal disturbance for airport operations.

ADB SAFEGATE Support

Technical Support – Global

Customers in Europe, the Middle East, Africa and Asia Pacific are more than welcome to our portal for technical support. Trained in all areas of system issues, troubleshooting, quality control and technical assistance, our highly experienced Technical support specialists are available 24 hours a day, seven days a week to provide assistance over the phone.

Europe: **+32-2-722-17-11**

China: **+86-10-8476-0106**

Middle East and Africa: **+971-4-452-7575**

In the Americas, we also offer live technical support.

Live Technical Support – Americas

If at any time you have a question or concern about your product, contact ADB SAFEGATE's US-based technical support specialists, available 24 hours a day, seven days a week, to assist you via phone.

ADB SAFEGATE Americas Technical Service & Support (US & Canada) :**+1-800-545-4157**

ADB SAFEGATE Americas Technical Service & Support (Canada): **+1-905-631-1597**

ADB SAFEGATE Americas Technical Service & Support (International): **+1-614-861-1304**. For technical service press 3 and for sales support press 4.

We can also be reached via email during regular business hours.

Airfield and Gate: **techservice.us@adbsafegate.com**

Gate: **gateservice.us@adbsafegate.com**

We look forward to working with you!

Before You Call

When you have an airfield lighting or control system problem, prior to calling, please ensure the following:

- Review the product's manual and troubleshooting guide.
- Be located with the product ready to troubleshoot.
- Have all necessary information available: airport code/company name, customer id number, contact phone number/email address, product/part number.
- Have all necessary tools that may be needed at hand.

When calling about an issue with Safedock A-VDGS, we can serve you better if you collect the following information before you call:

- Relevant information regarding the issue you are calling about, such as gate number, flight number, aircraft type and time of the event.
- What, if any, actions have been taken to resolve the issue prior to the call.
- If available, provide a CCTV recording of the incident to aid in aligning the information from the Safedock log file.

For more information, see www.adbsafegate.com, contact ADB SAFEGATE Support via email at **support@adbsafegate.com**.



A.1 ADB SAFEGATE Website

The ADB SAFEGATE website, www.adbsafegate.com, offers information regarding our airport solutions, products, company, news, links, downloads, references, contacts and more.

A.2 Recycling

A.2.1 Local Authority Recycling

The disposal of ADB SAFEGATE products is to be made at an applicable collection point for the recycling of electrical and electronic equipment. The correct disposal of equipment prevents any potential negative consequences for the environment and human health, which could otherwise be caused by inappropriate waste handling. The recycling of materials helps to conserve natural resources. For more detailed information about recycling of products, contact your local authority city office.

A.2.2 ADB SAFEGATE Recycling

ADB SAFEGATE is fully committed to environmentally-conscious manufacturing with strict monitoring of our own processes as well as supplier components and sub-contractor operations. ADB SAFEGATE offers a recycling program for our products to all customers worldwide, whether or not the products were sold within the European Union (EU).

ADB SAFEGATE products and/or specific electrical and electronic component parts which are fully removed/separated from any customer equipment and returned will be accepted for our recycling program.

All items returned must be clearly labeled as follows:

- For Restriction of Hazardous Substances (*RoHS*)/Waste Electrical and Electronic Equipment (*WEEE*) Recycling
- Sender contact information (Name, Business Address, Phone number).
- Main Unit Serial Number.

ADB SAFEGATE will continue to monitor and update according for any future requirements for *EU directives* as and when *EU member states* implement new *regulations* and or *amendments*. It is our aim to maintain our *compliance plan* and assist our customers.

WWW.ADBSAFEGATE.COM

Empowering the Airside **Evolution**

SMARTER. BETTER. **NOW.**

