

Model 6498

Present Weather and Visibility Sensor

A.0 Disclaimer / Standard Warranty

CE certification

The equipment listed as CE certified means that the product complies with the essential requirements concerning safety and hygiene. The European directives that have been taken into consideration in the design are available on written request to ADB SAFEGATE.

ETL certification

The equipment listed as ETL certified means that the product complies with the essential requirements concerning safety and C22.2 No.180:13 (R2018) regulations. The CSA directives that have been taken into consideration in the design are available on written request to ADB SAFEGATE.

All Products Guarantee

ADB SAFEGATE will correct by repair or replacement per the applicable guarantee below, at its option, equipment or parts which fail because of mechanical, electrical or physical defects, provided that the goods have been properly handled and stored prior to installation, properly installed and properly operated after installation, and provided further that Buyer gives ADB SAFEGATE written notice of such defects after delivery of the goods to Buyer. Refer to the Safety section for more information on Material Handling Precautions and Storage precautions that must be followed.

ADB SAFEGATE reserves the right to examine goods upon which a claim is made. Said goods must be presented in the same condition as when the defect therein was discovered. ADB SAFEGATE further reserves the right to require the return of such goods to establish any claim.

ADB SAFEGATE's obligation under this guarantee is limited to making repair or replacement within a reasonable time after receipt of such written notice and does not include any other costs such as the cost of removal of defective part, installation of repaired product, labor or consequential damages of any kind, the exclusive remedy being to require such new parts to be furnished.

ADB SAFEGATE's liability under no circumstances will exceed the contract price of goods claimed to be defective. Any returns under this guarantee are to be on a transportation charges prepaid basis. For products not manufactured by, but sold by ADB SAFEGATE, warranty is limited to that extended by the original manufacturer. This is ADB SAFEGATE's sole guarantee and warranty with respect to the goods; there are no express warranties or warranties of fitness for any particular purpose or any implied warranties of fitness for any particular purpose or any implied warranties other than those made expressly herein. All such warranties being expressly disclaimed.

Standard Products Guarantee

Products manufactured by ADB SAFEGATE are guaranteed against mechanical, electrical, and physical defects (excluding lamps) which may occur during proper and normal use for a period of two years from the date of exworks delivery, and are guaranteed to be merchantable and fit for the ordinary purposes for which such products are made.

NOTE



See your applicable sales agreement for a complete warranty description.

Replaced or repaired equipment under warranty falls into the warranty of the original delivery. No new warranty period is started for these replaced or repaired products.

FAA Certified products manufactured by ADB SAFEGATE

ADB SAFEGATE L858 Airfield Guidance Signs are warranted against mechanical and physical defects in design or manufacture for a period of 2 years from date of installation, per FAA AC 150/5345-44 (applicable edition).

ADB SAFEGATE LED products (with the exception of obstruction lighting) are warranted against electrical defects in design or manufacture of the LED or LED specific circuitry for a period of 4 years from date of installation, per FAA EB67 (applicable edition). These FAA certified constant current (series) powered LED products must be installed, interfaced and powered with and through products certified under the FAA Airfield Lighting Equipment Program (ALECP) to be included in this 4 (four) year warranty. This includes, but is not limited to, interface with products such as Base Cans, Isolation Transformers, Connectors, Wiring, and Constant Current Regulators.

Revision History

Revision	Date	Summary of Changes
A	2014 Oct 30	Initial release
B	2017 Nov 20	Added Day/Night Sensor and updated calibration instructions
C	2020 Oct 1	Updated options in Section 1.3 and corrected fuse part number, added Chapter 3 explaining how present weather data are determined, added all possible SYNOP codes reported in Table 8, added information on how to perform annual check of Day/Night sensor, updated visibility calibration temperature range
D	2021 June 30	Removed mention of mounting on the side of a tower, added Maintenance Interface Module wiring, added clarifications for calibration procedure, added Direct Connect Models for use with 1192 DCP
E	2025 Apr 1	ADB SAFEGATE (ECP#ADBSG-0001)

Contents

1. Overview	6
1.1 Features.....	6
1.2 Models.....	6
1.3 Options And Parts List.....	7
2. Visibility	8
2.1 Definitions.....	8
2.2 Units And Scales.....	9
2.3 Meteorological Requirements.....	9
2.4 Measurement Methods	9
2.5 Basic Equations	10
2.5.1 Meteorological Visibility in Daylight.....	11
2.5.2 Meteorological Visibility at Night	12
3. Principle Of Operation	13
4. System Description	15
4.1 Sensor Heads.....	16
4.2 Electronics Enclosure	16
4.2.1 Universal Power and Communication Module (UPCM).....	17
4.2.1.1 Maintenance Module.....	17
5. Installation.....	18
5.1 Siting And Installation Guidelines.....	18
5.2 Mast Installation	20
5.3 Conduit And Junction Boxes.....	21
5.4 Sensor Installation	23
5.4.1 Sensor Head Installation.....	24
5.4.2 Electronics Enclosure Installation (Standalone Sensors Only).....	25
5.4.3 Grounding	26
5.5 Electrical Connections	28
5.5.1 Direct Connect to Model 1192DCP	29
5.5.2 Electronics Enclosure (Standalone Sensors)	30
5.5.3 Configuring Serial Output 1	34
6. Operation With An AWOS.....	36
6.1 Direct Connect sensors.....	36
6.2 Standalone Sensors.....	37
6.2.1 Topic Poll.....	37
6.2.2 CP Sensor Poll Commands.....	41
6.3 Checksum Calculation	44
7. Maintenance And Troubleshooting	46
7.1 Monthly Maintenance	46
7.2 Triannual Maintenance.....	46
7.3 Annual Maintenance.....	46

7.4 Trouble Shooting.....	47
8. Calibration	48
8.1 Connections	49
8.1.1 Direct Connect Sensors.....	49
8.1.2 Standalone Sensors.....	50
8.2 Calibration Procedure.....	52
8.2.1 Analyzing the Calibration Values.....	56
8.3 Dirty Window Zero Calibration.....	57
9. Accessories.....	59
9.1 Day/Night Sensor Kit.....	59
9.1.1 Specifications	60
9.2 Background Luminance Sensor Kit	60
9.2.1 Specifications	61
10. Specifications	62
11. Warranty	64

1. Overview

The Model 6498 Present Weather and Visibility Sensor is an infrared forward-scatter present weather sensor used for automatic weather observation. The 6498 uses the well-established forward-scatter system for visibility measurement, using a 42° scatter angle. The 6498 uses high-speed sampling to reduce missed events such as rain and hail, and improves response to other suddenly changing conditions. It identifies precipitation particles from their scattering properties and fall speeds, and combines this with a temperature measurement to identify the weather type. The 6498 has downward-pointing optics that reduce the risk of contamination of the optics and blockage with snow.

1.1 Features

- Uses a 42° scatter angle for good visibility readings in all precipitation types
- Reports present weather information in the form of METAR and/or SYNOP codes
- Downward-facing optics minimizes dirt and snow build up
- Incorporates dew and hood heaters for ADB Safegate operation
- Reports present weather data and precipitation accumulations*
- Field calibratable
- Automatic fault/contamination detection
- Sampling zone clear of disturbance from the mounting and the electronics enclosure
- High immunity to interference from visible and infrared warning lights

Power and a serial interface are provided either by

- The Model 2715 Universal Power and Communication Module (UPCM) for standalone sensors, or
- The Model 1192 Data Collection Platform for Direct Connect sensors.

* The precipitation accumulation data from the Model 6498 Present Weather and Visibility Sensor are not used in the AWOS 3000.

1.2 Models

There are several variations of the Model 6498 Present Weather and Visibility Sensor available depending on the desired outputs.

- The standalone models can be used independently and have their own power supply and communication interface.
- The Direct Connect models are configured specifically for use with the Model 1192 Data Collection Platform (DCP). These models are powered from the Model 1192 DCP and are set up to interface only with the Model 1192 DCP.

Standalone Models	Direct Connect Models	Description
6498*	—	Present Weather and Visibility
6498-P	6498-DC-P	Present Weather
6498-PV	6498-DC-PV	Present Weather and Visibility
6498-V	6498-DC-V	Visibility

* This is the original Model 6498 Present Weather and Visibility Sensor sold only outside the U.S.

Table 1. 6498 Models

1.3 Options And Parts List

The options in Table 2 are available for the Model 6498 Present Weather and Visibility Sensor.

Part Number	Description
M403326-01	Day/Night Sensor Kit
M488600-00	Background Luminance Sensor Kit
M482264-00*	Radar Precipitation Detector
M482295-00†	Digital Temperature/Relative Humidity Probe

* Augments Present Weather reports to include freezing rain, sleet, and hail (used outside the U.S.)

† Improves Present Weather reporting at or near freezing temperatures (used outside the U.S.)

Table 2. Model 6498 Options

The replacement parts and accessories in Table 3 are available for the Model 6498 Present Weather and Visibility Sensor.

Part Number	Description
2715*	Universal Power and Communication Module (UPCM)
2715-P	Replacement UPCM for 6498-P
2715-PV	Replacement UPCM for 6498-PV
2715-V	Replacement UPCM for 6498-V
M442071	10 A 250 V, 5x20 mm slow blow fuse
M438130-00	Backup Battery
M482254-00	Calibration Kit
M482243-00	Replacement Sensor Head
M488594-00	Maintenance Module Kit

* This is the standard Model 2715 Universal Power and Communication Module sold only outside the U.S.

Table 3. Model 6498 Replacement Parts and Accessories



NOTE

The three variations of the 2715 Universal Power and Communications Module are specific to the specific Model 6498 sensor.

2. Visibility

2.1 Definitions

Visibility was first defined for meteorological purposes as a quantity to be estimated by a human observer, and observations made in that way are widely used. However, the estimation of visibility is affected by many subjective and physical factors. The essential meteorological quantity, which is the transparency of the atmosphere, can be measured objectively, and is represented by the meteorological optical range (MOR).

The *meteorological optical range* is the length of path in the atmosphere required to reduce the luminous flux in a collimated beam from an incandescent lamp, at a color temperature of 2700 K, to 5% of its original value, the luminous flux being evaluated by means of the photometric luminosity function of the International Commission on Illumination (ICI).

Meteorological visibility by day is defined as the greatest distance at which a black object of suitable dimensions, located near the ground, can be seen and recognized when observed against a scattering background of fog, sky, etc. It should be emphasized that the criterion for recognizing an object, and not merely for seeing the object without recognizing what it is, should be used.

Meteorological visibility at night is defined as:

- a. The greatest distance at which a black object of suitable dimensions could be seen and recognized, if the general illumination were raised to the normal daylight level; or
- b. The greatest distance at which lights of moderate intensity can be seen and identified.

Airlight is light from the Sun and the sky which is scattered into the eyes of an observer by atmospheric suspensoids (and, to a slight extent, by air molecules) lying in the observer's cone of vision. That is, airlight reaches the eye in the same manner as diffuse sky radiation reaches the Earth's surface. Airlight is the fundamental factor limiting the daytime horizontal visibility for black objects because its contributions, integrated along the cone of vision from eye to object, raise the apparent luminance of a sufficiently remote black object to a level which is indistinguishable from that of the background sky. Contrary to subjective estimate, most of the airlight entering an observer's eye originates in portions of his cone of vision lying rather close to him.

The following four photometric qualities are defined in detail in various standards, such as the International Electrotechnical Commission (IEC, 1987):

- a. Luminous flux (symbol: F (or F_v), unit: lumen) is a quantity derived from radiant flux by evaluating the radiation according to its action upon the ICI standard photometric observer;
- b. Luminous intensity (symbol: I , unit: candela or lm/sr) is luminous flux per unit solid angle;
- c. Luminance (symbol: L , unit: cd/m^2) is luminous intensity per unit area;
- d. Illuminance (symbol: E , unit: lux or lm/m^2) is luminous flux per unit area.

The *extinction coefficient* (symbol σ) is the proportion of luminous flux lost by a collimated beam, emitted by an incandescent source at a color temperature of 2700 K, while traveling the length of a unit distance in the atmosphere. The coefficient is a measure of the attenuation due to both absorption and scattering.

The *luminance contrast* (symbol C) is the ratio of the difference between the luminance of an object and its background and the luminance of the background.

The *contrast threshold* (symbol ϵ) is the minimum value of the luminance contrast that the human eye can detect, i.e., the value that allows an object to be distinguished from its background. The contrast threshold varies with the individual.

The *illuminance threshold* (E_t) is the smallest illuminance, at the eye, for the detection of point sources of light against a background of specified luminance. The value of E_t , therefore, varies according to lighting conditions.

The *transmission factor* (symbol T) is defined, for a collimated beam from an incandescent source at a color temperature of 2700 K, as the fraction of luminous flux which remains in the beam after traversing an optical path of a given length in the atmosphere. The transmission factor is also called the transmission coefficient. The terms transmittance or transmissive power of the atmosphere are also used when the path is defined, i.e., of a specific length (e.g., in the case of a transmissometer). In this case, T is often multiplied by 100 and expressed in percent.

2.2 Units And Scales

The meteorological visibility or MOR is expressed in meters or kilometers. The measurement range varies according to application. While for synoptic meteorological requirements, the scale of MOR readings extends from below 100 m to more than 70 km, the measurement range may be more restricted for other applications. This is the case for civil aviation where the upper limit may be 10 km. This range may be further reduced when applied to the determination of the runway visual range, which represents landing and takeoff conditions in reduced visibility. Runway visual range is required only between 50 and 1500 meters. For other applications, such as road or sea traffic, different limits may be applied according to both the requirements and the locations where the measurements are made.

The errors of visibility measurements increase in proportion to the visibility, and measurement scales take account of this. This fact is reflected in the code used for synoptic reports by the use of three linear segments with decreasing resolution, i.e., 100 to 5 000 m in steps of 100 m, 6 to 30 km in steps of 1 km, and 35 to 70 km in steps of 5 km. This scale allows visibility to be reported with a better resolution than the accuracy of the measurement, except when visibility is less than about 900 m.

The extinction coefficient may also be reported instead of the visibility. The units for the extinction coefficient may be scaled miles⁻¹ or km⁻¹, but only scaled miles⁻¹ units are output for the extinction coefficient in the 6498 output data.

2.3 Meteorological Requirements

The concept of visibility is used extensively in meteorology in two distinct ways. Firstly, it is one of the elements identifying air-mass characteristics, especially for the needs of synoptic meteorology and climatology. Here, visibility must be representative of the optical state of the atmosphere. Secondly, it is an operational variable which corresponds to specific criteria or special applications. For this purpose, it is expressed directly in terms of the distance at which specific markers or lights can be seen. One of the most important special applications is found in meteorological services to aviation.

The measure of visibility used in meteorology should be free from the influence of extra- meteorological conditions, but it must be simply related to intuitive concepts of visibility and to the distance at which common objects can be seen under normal conditions. MOR has been defined to meet these requirements, being convenient for instrumental methods by day and night, and having well-understood relations with other measures of visibility. MOR has been formally adopted by WMO as the measure of visibility for both general and aeronautical uses (WMO, 1990a). It is also recognized by the International Electrotechnical Commission (IEC, 1987) for application in atmospheric optics and visual signaling.

MOR is related to the intuitive concept of visibility through the contrast threshold. In 1924, Koschmieder, followed by Helmholtz, proposed a value of 0.02 for ϵ . Other values have been proposed by other authors. They vary from 0.0077 to 0.06, or even 0.2. The smaller value yields a larger estimate of the visibility for given atmospheric conditions. For aeronautical requirements, it is accepted that E is higher than 0.02, and it is taken as 0.05 since, for a pilot, the contrast of an object (runway markings) with respect to the surrounding terrain is much lower than that of an object against the horizon. It is assumed that when an observer can just see and recognize a black object against the horizon, the apparent contrast of the object is 0.05. This leads to the choice of 0.05 as the transmission factor adopted in the definition of MOR.

2.4 Measurement Methods

Visibility is a complex psychophysical phenomenon, governed mainly by the atmospheric extinction coefficient associated with solid and liquid particles held in suspension in the atmosphere. The extinction is caused primarily by scattering rather than by absorption of the light. Its estimation is subject to variations in individual perception and interpretative ability as well as the light source characteristics and the transmission factor. Thus, any visual estimate of visibility is subjective.

When visibility is estimated by a human observer it depends not only on the photometric and dimensional characteristics of the object which is, or should be, perceived, but also on the observer's contrast threshold. At night, it depends on the intensity of the light sources, the background illuminance and, if estimated by an observer, on the adaptation of the observer's eyes to darkness and the observer's illuminance threshold. The estimation of visibility at night is particularly problematic. The first definition of visibility at night provided at the beginning of this chapter is given in terms of equivalent daytime visibility in order to ensure that no artificial changes occur in estimating the visibility at dawn and at twilight. The second definition has practical applications especially for aeronautical requirements, but it is not the same as the first and usually gives different results. Both are evidently imprecise.

Instrumental methods measure the extinction coefficient from which the MOR may be calculated. The visibility may then be calculated from knowledge of the contrast and illuminance thresholds, or by assigning agreed values to them. However, fixed instruments are used on the assumption that the extinction coefficient is independent of distance. Some instruments measure attenuation directly and others measure scattering of light to derive the extinction coefficient. The brief analysis of the physics of visibility in this chapter may be useful for understanding the relations between the various measures of the extinction coefficient, and for considering the instruments used to measure it.

2.5 Basic Equations

The basic equation for visibility measurements is the Bouguer-Lambert law:

$$F = F_0 e^{-\sigma x} \quad (1)$$

where F is the luminous flux received after a length of path x in the atmosphere and F_0 is the flux for $x = 0$. Differentiating, we obtain:

$$\sigma = -\frac{dF}{F} \cdot \frac{1}{dx} \quad (2)$$

NOTE



This law is valid only for monochromatic light, but may be applied to a spectral flux to a good approximation. The transmission factor is:

$$T = \frac{F}{F_0} \quad (3)$$

Mathematical relationships between MOR and the various variables representing the optical state of the atmosphere may be deduced from the Bouguer-Lambert law. From Equations 1 and 3 we may write:

$$T = \frac{F}{F_0} = e^{-\sigma x} \quad (4)$$

If this law is applied to the MOR definition, $T = 0.05$, then $x = P$, and the following may be written:

$$T = 0.05 = e^{-\sigma P} \quad (5)$$

Hence, the mathematical relation of MOR to the extinction coefficient is:

$$P = \left[\frac{1}{\sigma} \right] \cdot \ln \left[\frac{1}{0.05} \right] \approx \frac{3}{\sigma} \quad (6)$$

where \ln is the log to base e , or the natural logarithm. When combining Equation 4, after being deduced from the Bouguer-Lambert law, and Equation 6, the following equation is obtained.

$$P = x \cdot \frac{\ln(0.05)}{\ln(T)} \quad (7)$$

This equation is used as a basis for measuring MOR with transmissometers.

2.5.1 Meteorological Visibility in Daylight

The contrast of luminance is:

$$C = \frac{L_b - L_h}{L_h} \quad (8)$$

where L_h is the luminance of the horizon, and L_b is the luminance of the object.

The luminance of the horizon arises from the light scattered from the atmosphere along the observer's line of sight. It should be noted that if the object is darker than the horizon, then C is negative, and that if the object is black ($L_b = 0$), then $C = -1$.

In 1924, Koschmieder established a relationship, which later became known as Koschmieder's law, between the apparent contrast (C_x) of an object, seen against the horizon sky by a distant observer, and its inherent contrast (C_o), i.e., the contrast that the object would have against the horizon when seen from very short range. Koschmieder's relationship can be written as:

$$C_x = C_o e^{-\sigma x} \quad (9)$$

This relationship is valid provided the scatter coefficient is independent of the azimuth angle and there is uniform illumination along the whole path between the observer, the object, and the horizon. If a black object is viewed against the horizon ($C_o = -1$) and the apparent contrast is -0.05 , then Equation 9 reduces to:

$$0.05 = e^{-\sigma x} \quad (10)$$

Comparing this result with Equation 5 shows that when the magnitude of the apparent contrast of a black object seen against the horizon is 0.05 , then that object is at MOR (P).

2.5.2 Meteorological Visibility at Night

The distance at which a light (a night visibility marker) can be seen at night is not simply related to MOR. It depends not only on MOR and the intensity of the light, but also on the illuminance at the observer's eye from all other light sources.

In 1876, Allard proposed the law of attenuation of light from a point source of known intensity (I) as a function of distance (x) and extinction coefficient (σ). The illuminance (E) of a point light source is given by:

$$E = I \cdot r^{-2} \cdot e^{-\sigma x} \tag{11}$$

When the light is just visible, $E = E_t$ and the following may be written:

$$P = \left[\frac{1}{r} \right] \cdot \ln \left[\frac{1}{E_t \cdot x^2} \right] \tag{12}$$

Noting that $P = (I/a) \cdot \ln (1/0.05)$ in Equation 6, we may write:

$$P = r \cdot \frac{\ln \left[\frac{1}{0.05} \right]}{\ln \left[\frac{1}{E_t \cdot x^2} \right]} \tag{13}$$

3. Principle Of Operation

The 6498 has an emitter and detector aligned as shown in Figure 1.

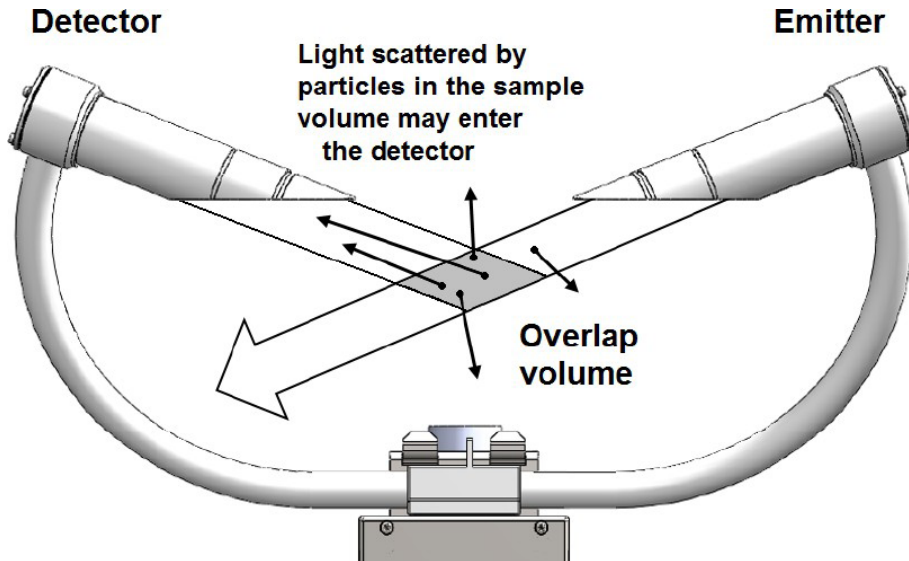

Figure 1. Sample Volume

The emitter produces a beam of near infrared light pulsed at 1 kHz. A detector has a field of view which overlaps the beam and is inclined at 42 degrees to it. Particles in the sample volume scatter light in all directions, including into the detector.

Light scattered by a particle (for example, a fog droplet or particle of precipitation) from the overlap or sample volume towards the detector is detected by a photodiode and recorded as a signal. The size of the signal is therefore proportional to the extinction of the emitted beam caused by scattering. The scattering signal averaged over one second is used to calculate an extinction coefficient. Sixty one-second averages are then themselves averaged to give a one- minute average extinction coefficient, which is then converted to a value of Meteorological Optical Range (MOR) using Koschmieder's law (see Section 2.5).

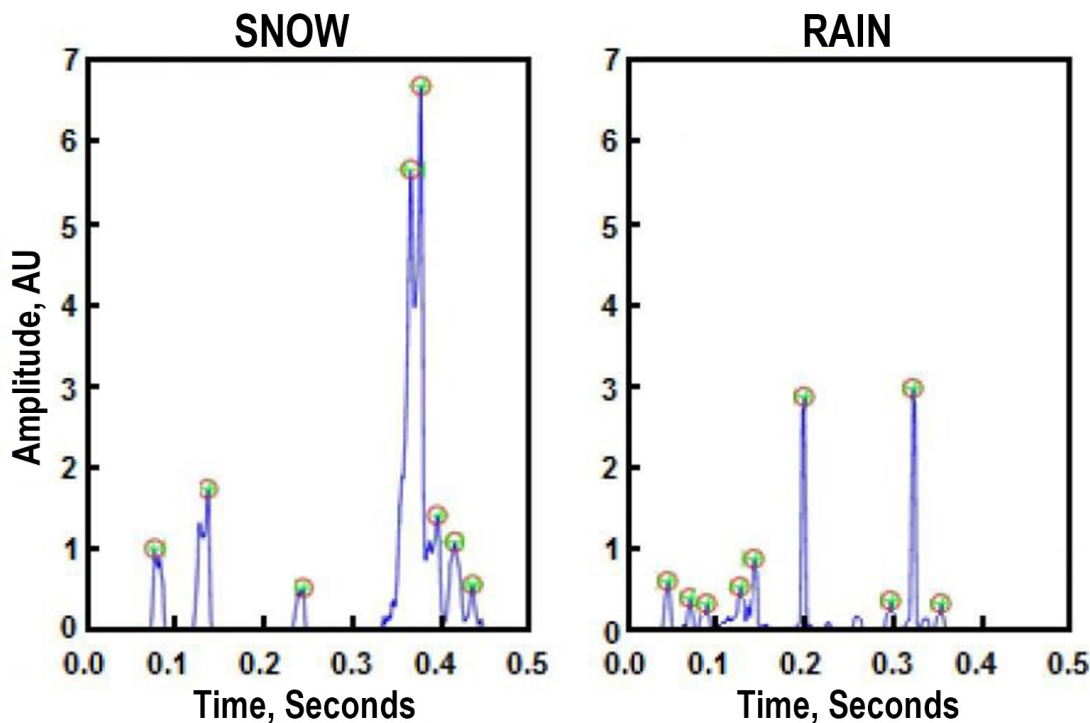

Figure 2. Comparing Signals from Snow Flakes and Rain Drops

Model 6498 Present Weather and Visibility Sensor

The 6498 is capable of identifying weather type in addition to measuring visibility. It does this by analyzing the amplitude and width of spikes in the signal corresponding to particles of precipitation passing through the sample volume. The amplitude of the signal is a guide to the size of the particle and the width, because it represents the time taken for the particle to fall through the sample volume, is proportional to the fall speed, see Figure 2.

The 6498 also has a built-in temperature sensor. The three parameters, fall speed, size, and temperature are used to identify the type of particle. If a separate external digital temperature/ relative humidity probe is connected, then a wet-bulb temperature can be calculated. This provides useful additional information identifying particles more accurately, especially liquid vs. frozen around 0°C.

The processing algorithm then works with several proprietary "maps" to identify each particle.

4. System Description

Figure 3 compares the installation of the standalone and Direct Connect Present Weather/ Visibility sensors. The optional Background Luminance Sensor accessory described in Section 9.2 is also shown.

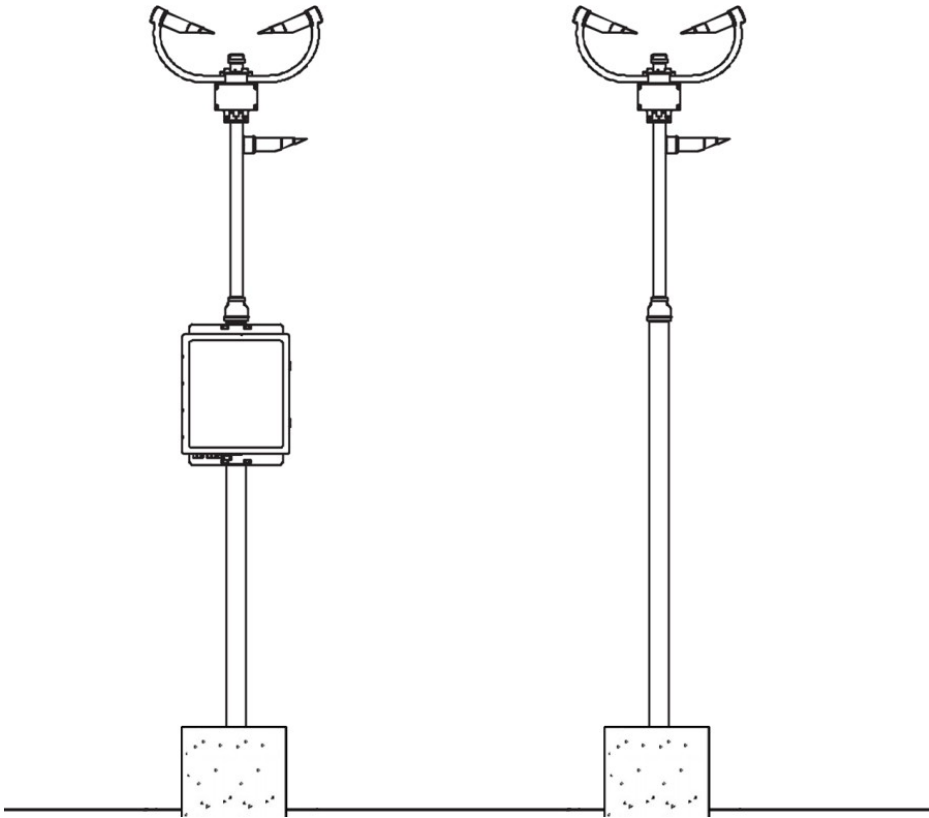

Figure 3. Standalone and Direct Connect Present Weather/Visibility Installations

4.1 Sensor Heads

The 6498 has two sensor heads, the emitter head and the detector head.

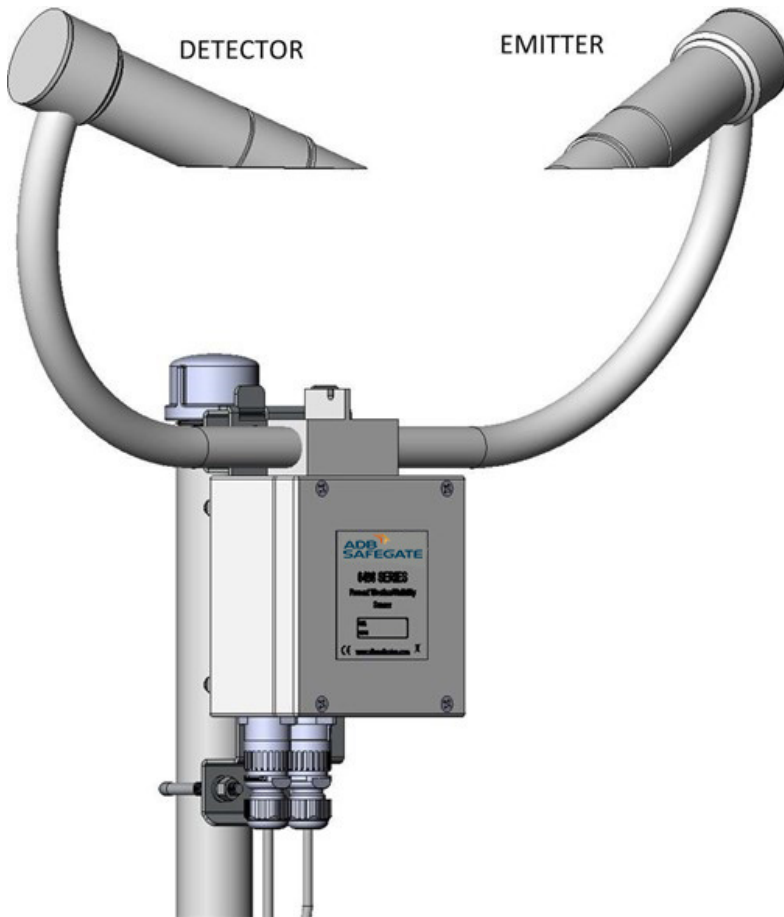

Figure 4. Present Weather and Visibility Sensor Heads

The sensor heads are heated to prevent dew, frost, and snow from building up on the lenses, and are self-regulating devices. They are “on” continuously, drawing more current when the outside temperature is cold and less current when the temperature is warm. The sensor head enclosure has a heater located in the top of the enclosure to minimize snow and ice buildup near the center of the sensor heads. The sensor heads are completely sealed from water intrusion at the factory. Exercise care should to avoid drilling or otherwise puncturing the frame.

4.2 Electronics Enclosure

The standalone sensors consist of two enclosures, one large electronics enclosure and a smaller enclosure with the sensor heads mounted on it.

The larger enclosure contains the Universal Power and Communication Module and the Maintenance Module. The UPCM contains surge protection for the power and serial lines.

The smaller enclosure, which is the only enclosure for the *Direct Connect sensors*, contains the sensor head control board. The control board performs all of the data processing and temperature control for the Present Weather and Visibility Sensor head. This control board also controls the Day/Night sensor accessory option.

4.2.1 Universal Power and Communication Module (UPCM)

The UPCM is located inside the larger electronics enclosure for the standalone sensors. The enclosure is a fiberglass NEMA-4X type box with a hinged access door. Figure 5 shows the layout of the enclosure.

The UPCM serves as the interface between the 6498 and the data processing system such as the Central Data Processor in an Automated Weather Observing System. It provides the power to the 6498, and collects the data to forward in response to a poll. The UPCM is field-replaceable. The correct UPCM configuration file must be installed for the sensor to function properly after replacement.

The UPCM has two different power switches. The AC power switch disconnects AC power from the UPCM. If there is solar or battery power connected, the UPCM will continue to function with no AC power source. The power supply switch disables the power supply section of the UPCM. When the power supply switch is off there will be no DC voltage coming from the power supply voltage regulators. When there is no DC voltage the UPCM processor will not function and no communications will pass through the UPCM.

There are two fuses that are in series with the AC power lines. They are located on the side of the UPCM (see Figure 5). Replace the fuses only with fuses of the same rating, as shown below.

- 10 A 250 V, 5×20 mm slow blow

4.2.1.1 Maintenance Module

The maintenance module allows a user to connect directly to the sensor communications bus between the sensor and the UPCM. This connection is used to calibrate the standalone Present Weather and Visibility Sensor head unit. (Direct Connect sensors are calibrated using the Ethernet connection on the Model 1192 DCP)

The user can connect to the maintenance module by connecting a laptop using a USB A/B cable. The USB B side of the cable connects into one of the USB B connectors on the bottom of the large electronics enclosure. The connector closer to the front of the enclosure is typically the connector for the 6498 sensor head. The other connector is used to connect to the Background Light Sensor when it is installed.

When the USB connector is plugged into the enclosure, power from the USB connector powers a relay which disconnects the sensor from the UPCM and connects it to an onboard USB-to-serial converter. The USB-to-serial converter driver must be installed on the laptop for a proper connection to be made. When the USB to serial converter serial port is correctly install in the operating system of the laptop the port can be opened by using a Terminal Program. The correct communication settings must be applied to the terminal program before the communications will function correctly between the sensor and the laptop.

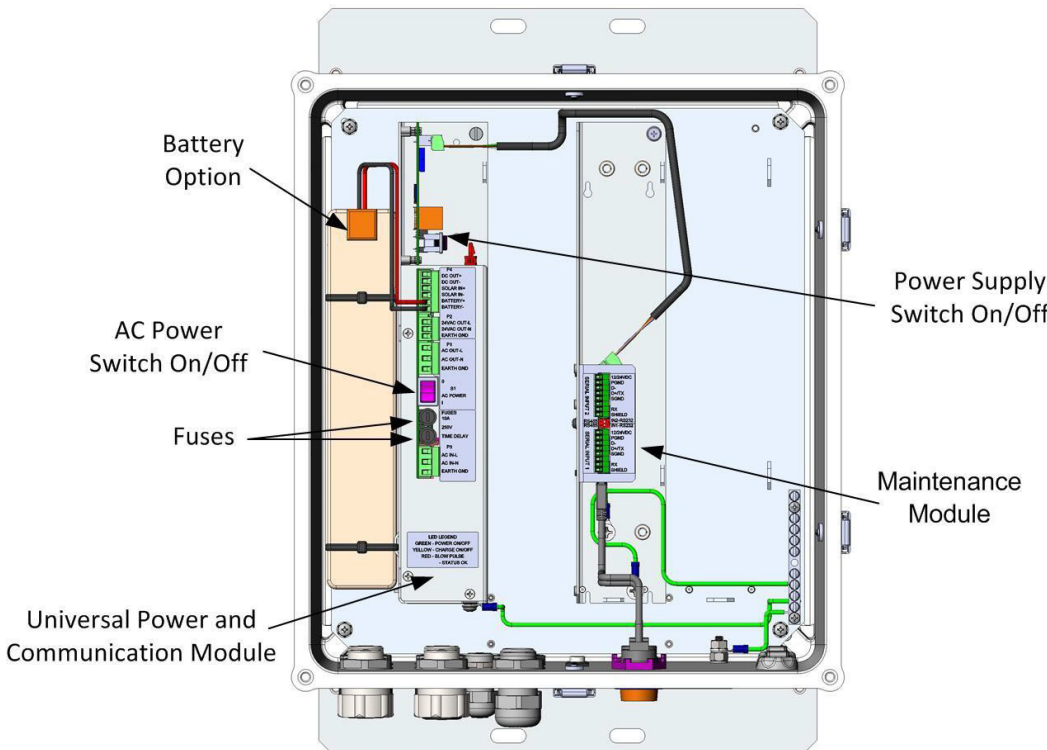

Figure 5. Present Weather and Visibility Standalone Sensor Fuses

5. Installation

5.1 Siting And Installation Guidelines

There are a few considerations to take into account if accurate and representative data are to be obtained.

ADB Safegate. recommends that the siting and installation follow the guidelines established by the Federal Aviation Administration (FAA). *Siting Criteria for Automated Weather Observing Systems*, FAA Order JO-6560-20C, as well as the following recommendations.

1. Distance from Obstructions — The distance between the sensor and obstructions such as trees or buildings should be at least 2 times the height of the obstruction on all sides. For example, if a tree 20 m high is located alongside the sensor, the sensor should be at least 40 m away from the tree. This restriction reduces the effects of wind turbulence created by the nearby obstruction and makes the precipitation measurement more representative. Do not locate the sensor where tree branches or wires will hang over the sensor!
2. Separation from Turbulence and Contamination Sources — Do not mount the sensor near building exhaust vents, strobe lights, or sources of smoke or steam. Where possible, locate the unit as far away from runways and roads as possible to reduce optics fouling from wind-blown road dirt. An ideal minimum distance is at least 30 m.

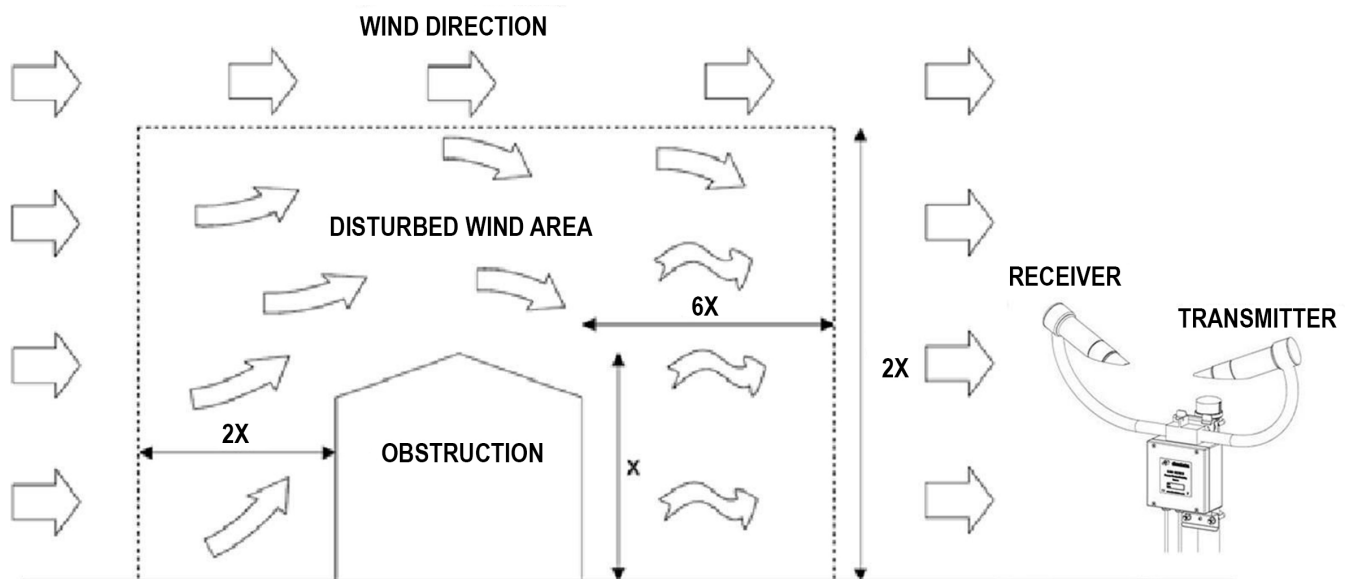

Figure 6. Siting Recommendations Relative to Obstructions

3. Sensor Height, Rigidity, Verticality, and Orientation — The OFCM recommends that the Present Weather and Visibility Sensor be mounted at a height of 10 ft (3 m). This height is not always possible because of constraints imposed by the site. Mounting the sensor head lower than 2 m or higher than 5 m is not generally recommended.

For AWOS installations, ADB Safegate. recommends that the sensor head be mounted on a pipe. If the pipe mast is more than 5 cm (2") in diameter, a mast coupling with a diameter of 5 cm (2") or less should be placed on top of the pipe.

The Model 6498 sensors may be mounted on the top of a building is acceptable if it located near the center of the building away from the wind turbulence that may occur near the edges. The installation must be rigid so that wind-induced vibration does not cause false alarms.

The sensor head must always be mounted level to within ± 2 degrees so that the line aperture on the in-beam lens is horizontal.

4. The sensor head is generally oriented with the transmitter head on the north side (in the Northern hemisphere) so that the receiver optics face north. Align the sensor head so that the receiver lens faces north. If the orientation can be altered to either side of north to obtain a "view" facing away from the sun with fewer or more distant obstructions or bright light sources, it is generally acceptable to alter the orientation up to ± 30 degrees from north. The transmitter head will be the south side (in the Southern hemisphere) so that the receiver optics face south.

Model 6498 Present Weather and Visibility Sensor

5. FAA Order JO-6560-20C provides specific locations and elevations where the Present Weather and Visibility Sensor must be sited with respect to the runway, taking into account whether RVR instrumentation and precision instrument runways are present.
6. General Recommendations
 - The sensor must be mounted level to within ± 2 degrees so that the line aperture on the in-beam lens is horizontal.
 - The sensor is generally oriented with the lenses facing away from highway or contamination sources to avoid dirt splash directly into the lenses.
 - The sensor should be oriented to avoid direct sunlight shining into the lenses.
 - The sensor should be located as far as practicable from strobe lights and other modulated light sources, as well as clusters of solar panels.

SUGGESTION: Take a picture at the installation site in each direction (north, east, south, and west) to record the topography and obstructions for future reference.

SITING GUIDELINES



- » Sensor heads mounted 2–5 m above ground
 - » Rigid mounting pole
 - » No overhanging trees, wires, or roof lines
 - » Distance between sensor and closest obstruction at least 2 times obstruction height
 - » As far from road, runway, and contamination sources as possible
 - » As required by FAA Order JO-6560-20C, Siting Criteria for Automated Weather Observing Systems
-

5.2 Mast Installation

The sensor head mounts near the top of a 1.5" (38 mm) mast section and the electronics enclosure for the standalone sensors mounts near the top of the 2.5" (64 mm) mast section, which provides the necessary rigidity for the mast. Construct a foundation for the mast according to the details in Figure 7. When embedding the mast in the concrete, make sure the mast is vertical to within ± 2 degrees. Bevel all pad edges.

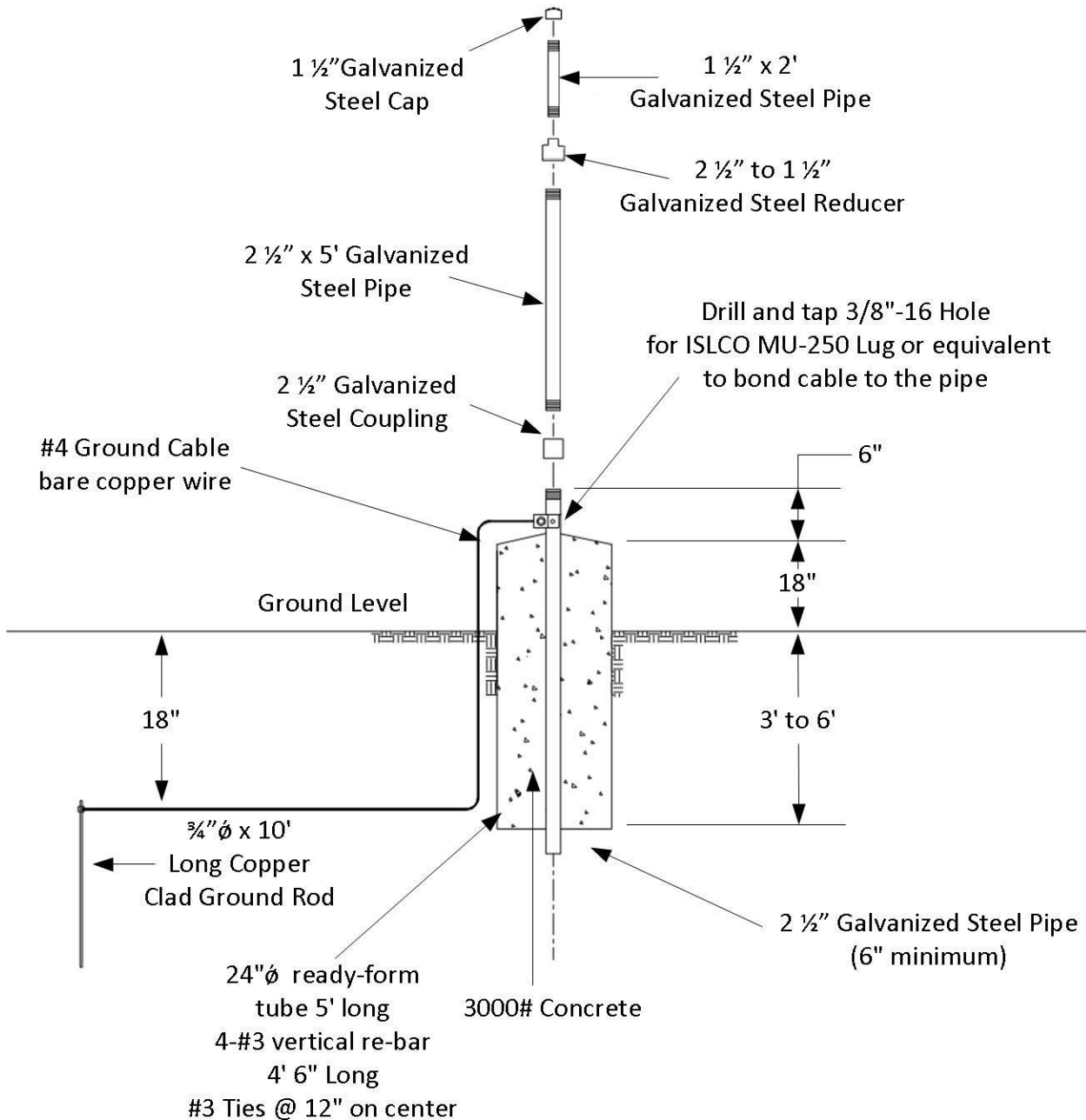

Figure 7. Sensor Foundation Installation

5.3 Conduit And Junction Boxes

For most installations, conduit should be routed to the sensor to accommodate the power line to the standalone sensor and the signal line from any sensor to the host computer or Data Collection Platform (DCP). For ease of connection, junction boxes can be installed near the base of the mast, and rigid or flex conduit installed between the junction boxes and the UPCM enclosure.

Figure 8 shows the conduit and junction box installation details for standalone sensors.

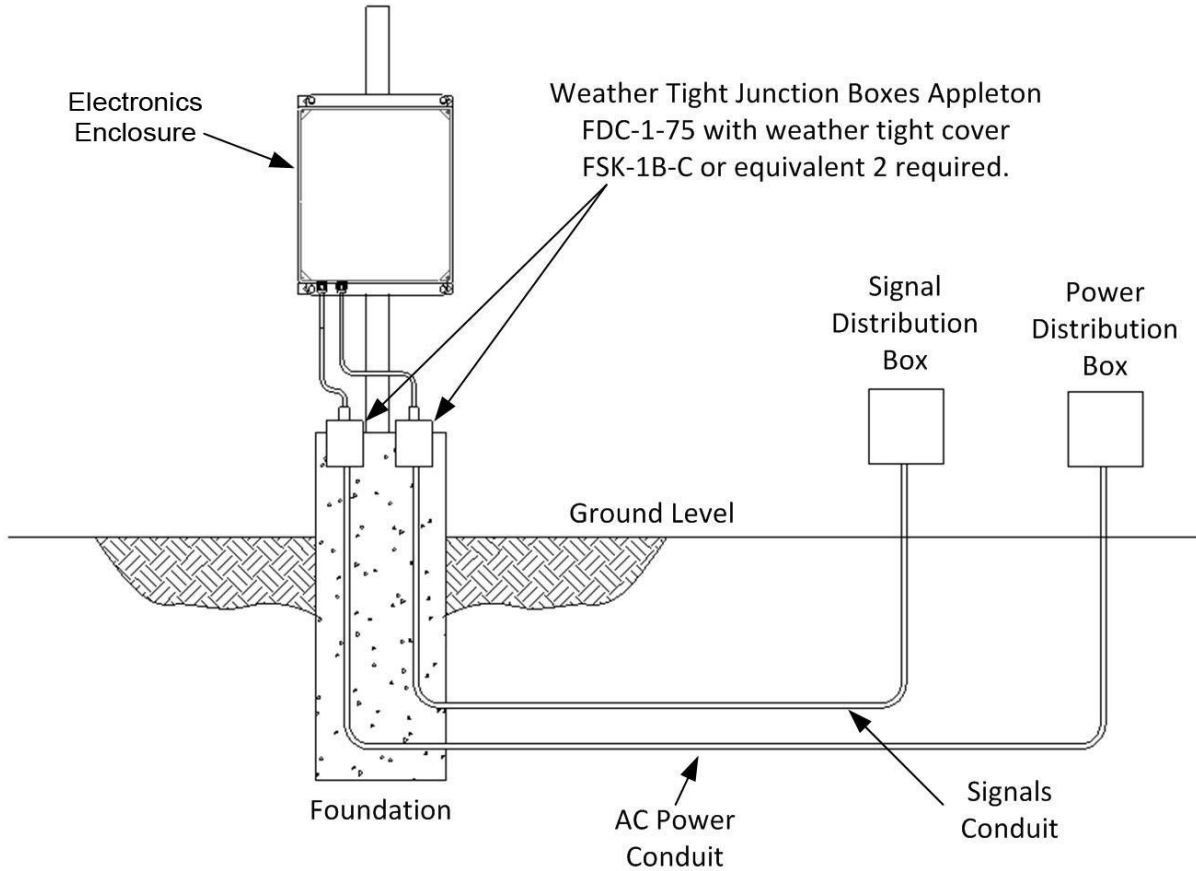

Figure 8. Sensor Conduit and Electrical Junction Box Installation for Standalone Sensors

Figure 9 shows the conduit and junction box installation details for Direct Connect sensors.

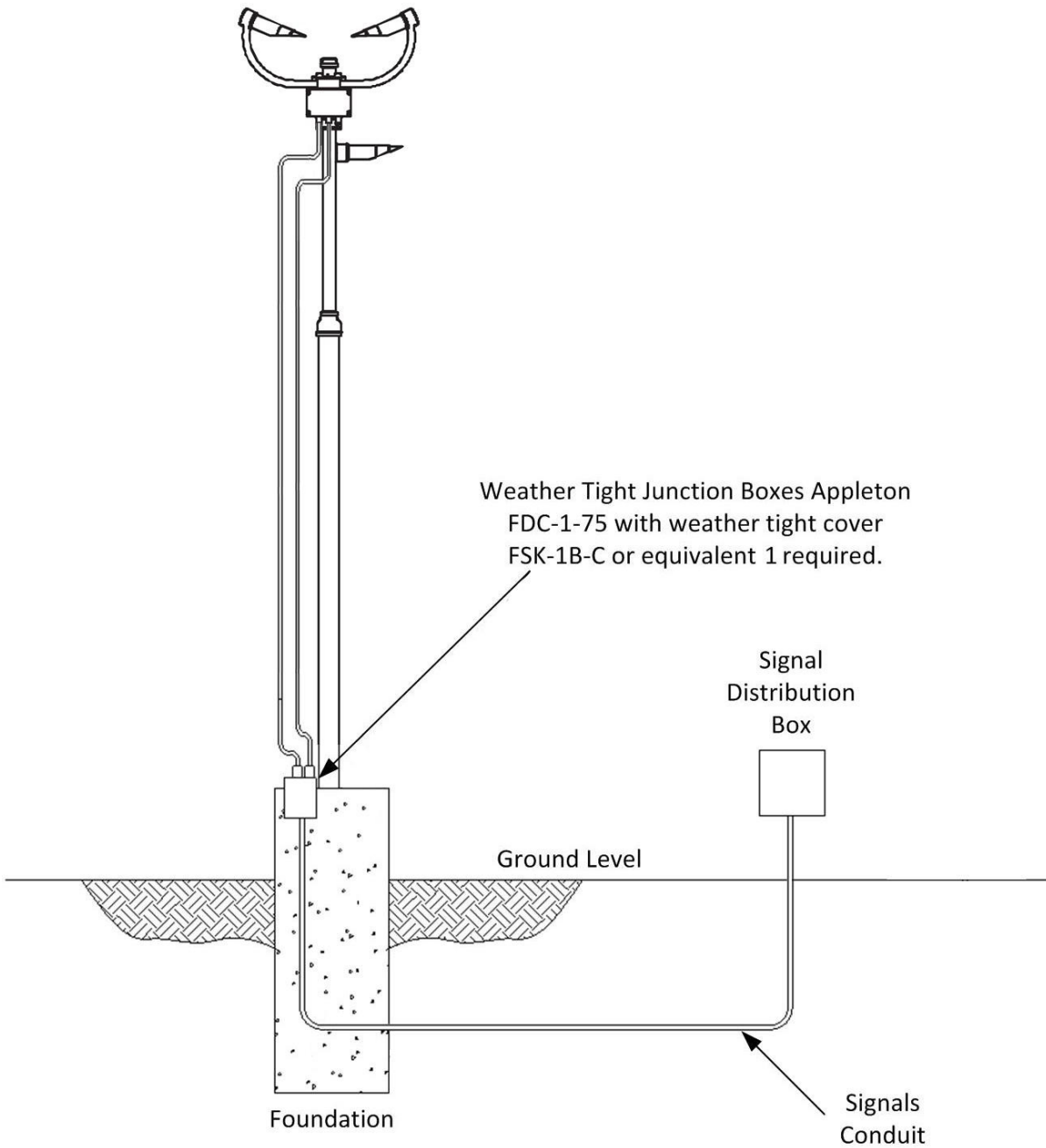

Figure 9. Sensor Conduit and Electrical Junction Box Installation for Direct Connect Sensors

5.4 Sensor Installation

There are two stages to the sensor installation, first the sensor head and then for standalone sensors the electronics enclosure. The sensor head and electronics enclosure are mounted to a pole that is installed into a study foundation. (Figure 10)

Only the sensor head is mounted for *Direct Connect* sensors.

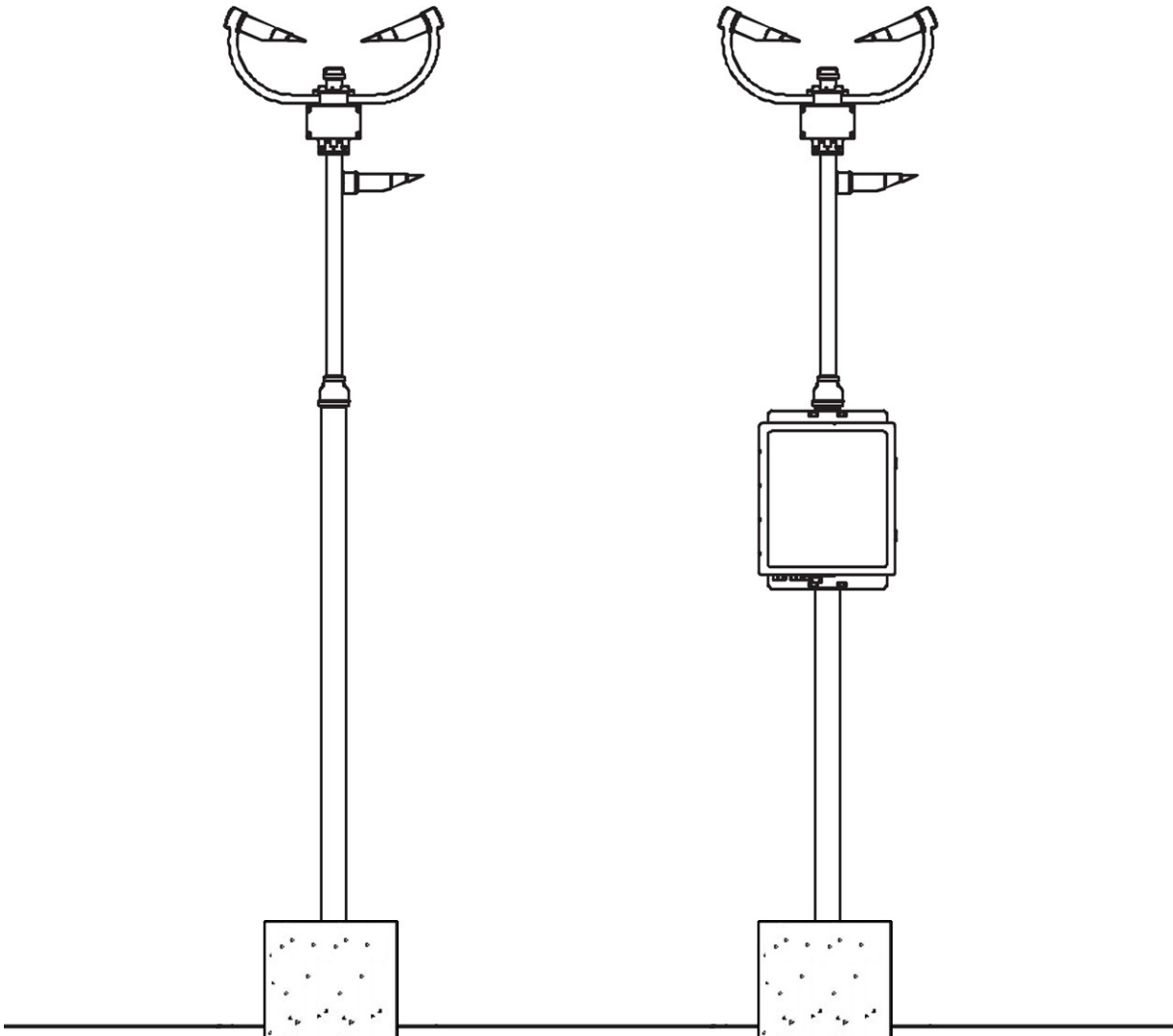

Figure 10 Stages in Sensor Installation

5.4.1 Sensor Head Installation

A pole mounting kit is supplied with the 6498 sensor head. The mounting kit will attach the sensor head near the top of a 1.5" (38 mm) pipe.

1. Position the top clamp as shown in Figure 11. Tighten the U bolt using the nuts and washers provided.

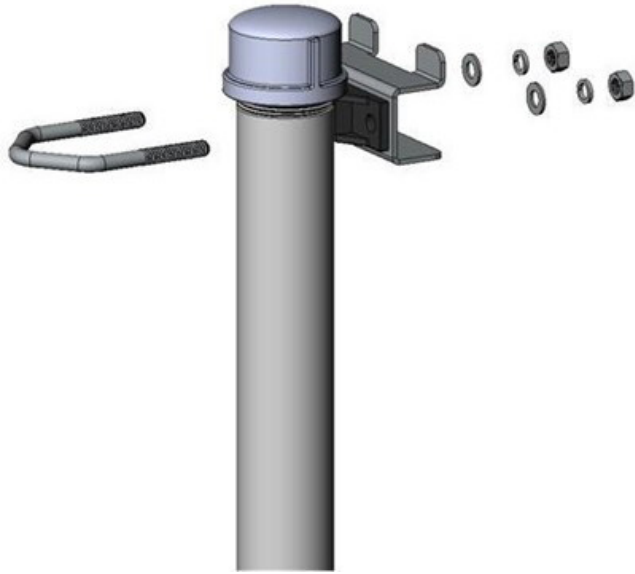

Figure 11. Mounting Present Weather and Visibility Sensor Step 1

2. Hook the sensor with the back plate on to the top bracket as shown in Figure 12. Tighten the U bolt using the nuts and washers provided to the bottom of the bracket.

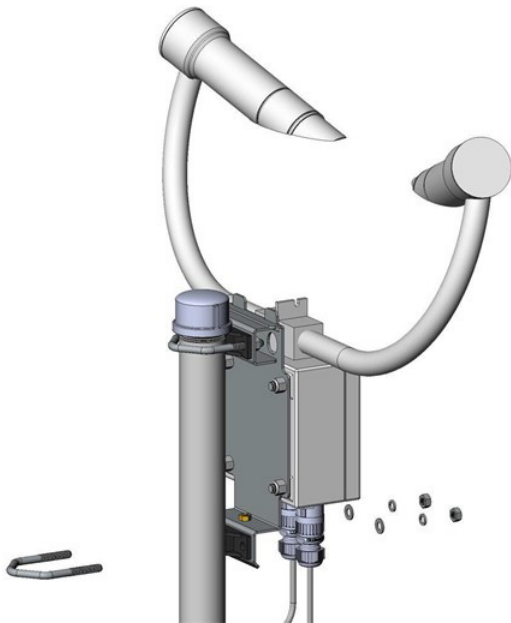

Figure 12. Mounting Present Weather and Visibility Sensor Step 2

Take care not to overtighten the nuts on the bolts, as it may be possible to distort and/or damage the brackets or DSP plate by doing so, and/or the nuts may seize up. Only tighten the nuts to a degree necessary to hold the 6498 firmly in place.



CAUTION

Do not reposition the 6498 by forcing the arms of the unit after it has been mounted, as this can cause damage.

5.4.2 Electronics Enclosure Installation (Standalone Sensors Only)

Attach the electronics enclosure to the pole using the hardware supplied with the UPCM. Two U-bolts are used to secure the enclosure to the pole.

These additional steps will help keep the mounting secure and corrosion-resistant.

- Apply anti-seize compound to all external threaded connections.
- Once the installation of the enclosure has been completed, apply a light spray of corrosion block to all metallic connectors and threaded fasteners.



Figure 13. Electronics Enclosure Mounting

5.4.3 Grounding

The 6498 sensor heads and electronics inside the electronics enclosure must be properly grounded using the grounding lug in the lower section of the sensor head (Figure 14) and the bottom of the electronics enclosure for standalone sensors (Figure 15). The ground wires are clamped to the mast, and a ground wire connects the wires at the clamp to a ground rod installed as part of the site preparation activities.

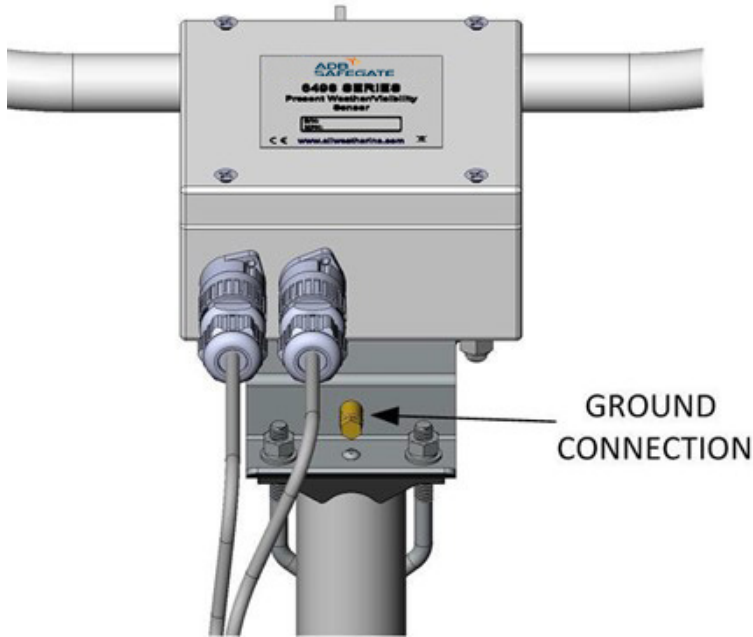

Figure 14. Sensor Grounding Lug



Figure 15. Electronics Enclosure Grounding Lug

Model 6498 Present Weather and Visibility Sensor

To install grounding, follow the steps below (see Figure 16).

1. Drill and tap a ¼ -20 hole in the mast. Install a grounding clamp in the hole.
2. Connect one end of a length of ground cable to the grounding clamp on the mast.
3. Connect the other end of the ground cable to the ground clamp on the underside of the enclosure.
4. Finally, connect a bare copper ground wire between the ground clamp on the mast and an installed ground rod.

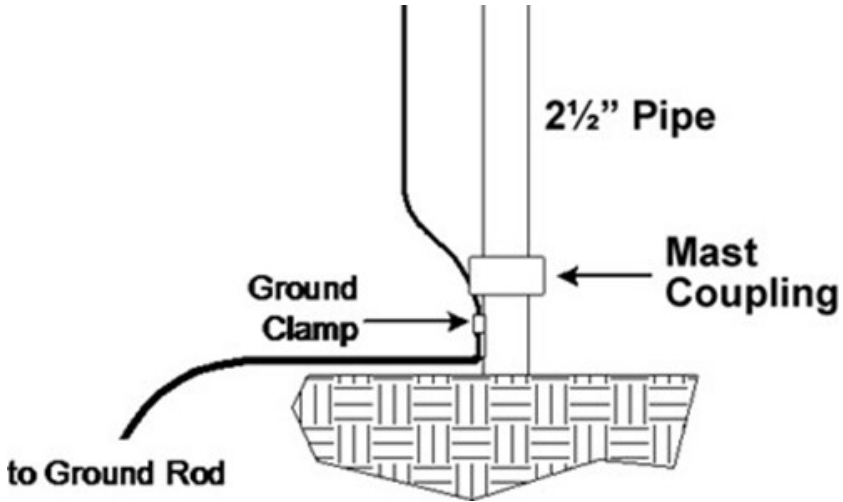

Figure 16. Grounding

5.5 Electrical Connections

The 6498 has two IP67 rated cable connectors with cables to connect the sensor head to the electronics enclosure (standalone sensors) or to the Model 1192 DCP (*Direct Connect sensors*). One cable carries DC power and data communications, the second cable connector carries 24 V AC for the sensor hood heaters. Figure 17 shows these cables and the ground connection.

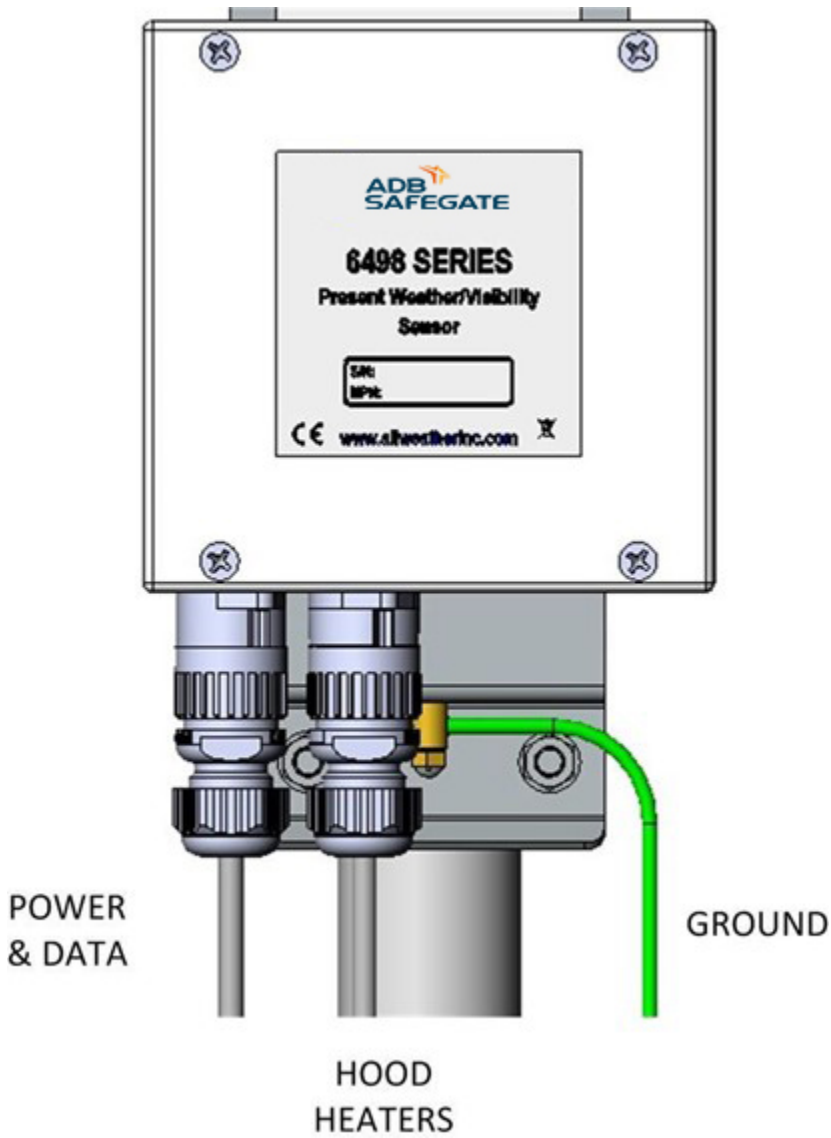

Figure 17. Present Weather and Visibility Sensor Head Cables

5.5.1 Direct Connect to Model 1192DCP

Before proceeding, verify that the power switch on the DCP is turned "OFF."

Route the cables from the sensor to the junction box near the base of the mounting mast. Secure the cables to the mast using tie-wraps or other straps. If the cables are not long enough to route through the signal conduit to the DCP, run separate cables through the conduit and connect them to the cables from the sensor head in the junction box.

Figure 18 summarizes the connections to the Model 1192 DCP.

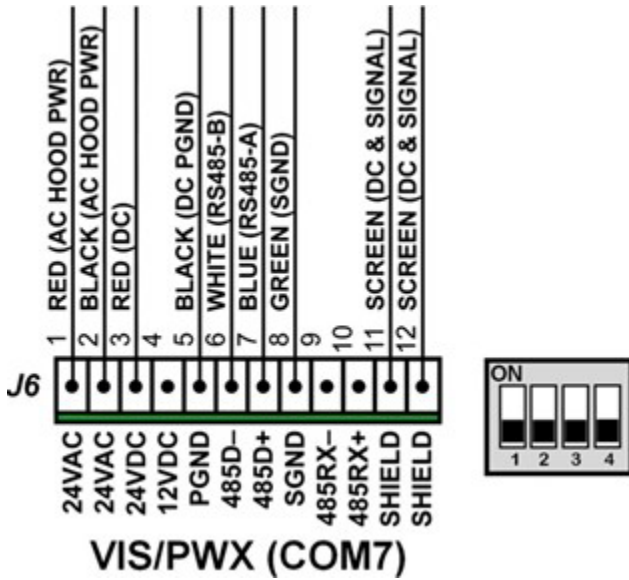

Figure 18. Model 6498-DC Present Weather and Visibility Sensor Direct Connect Signal and Power Wiring

5.5.2 Electronics Enclosure (Standalone Sensors)

Figure 19 shows the external connections at the bottom of the electronics enclosure.

- AC power conduit
- Power and data cable from sensor
- Heater cable from sensor
- Conduit for serial cable to DCP (for domestic AWOS 3000 installations) or CDP
- Groundlug
- Maintenance Port

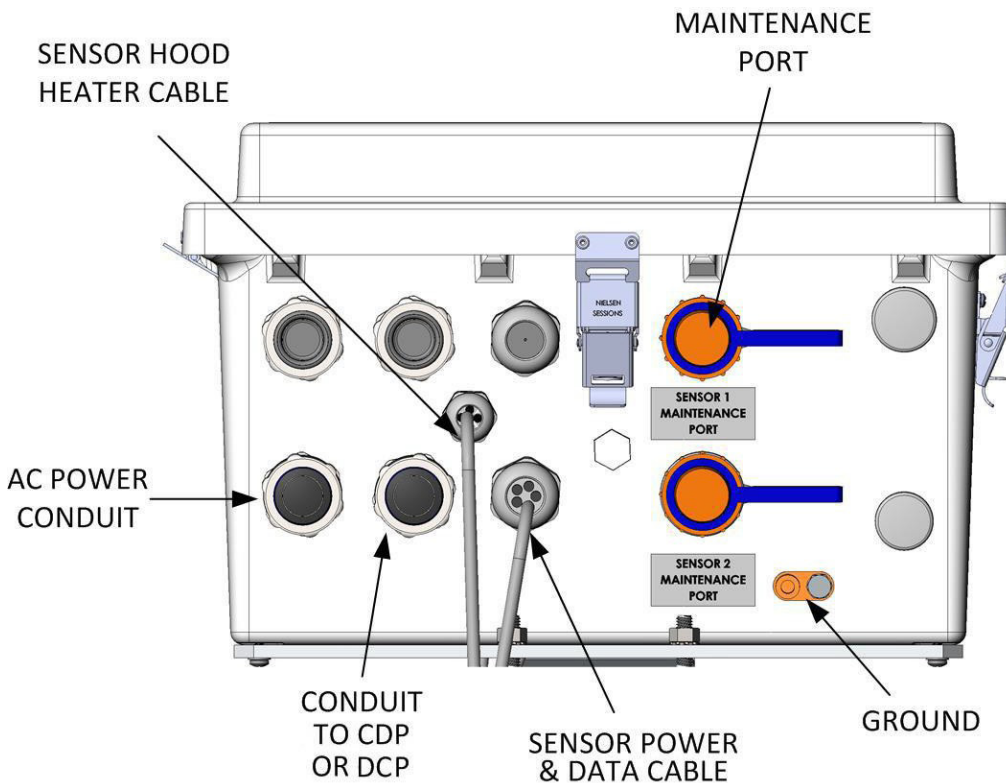

Figure 19. External Connections at Enclosure Bottom for Standalone Sensors

5.5.2.1 Connecting the Sensor Head to the Electronics Enclosure

Before proceeding, verify that the power switch on the UPCM is turned "OFF."

Route the cables from the sensor to the bottom of the electronics enclosure. Secure the cable to the mast using tie-wraps or other straps.

1. Route the cables from the sensor head into the electronics enclosure through the cable glands shown in Figure 19.
2. Connect the wires from the power and data cable using a friction lock connector to Serial Output P1 on the UPCM Sensor Maintenance Interface Module inside the enclosure shown in Figure 20 according to the wiring information in Section 5.5.2.2. The serial port connectors on the Maintenance Interface module are the same pinout as the UPCM.
3. Connect the wires from the heater cable using a friction lock connector to P2 (24 VAC OUT) on the UPCM inside the enclosure shown in Figure 20 according to the wiring information in Section 5.5.2.2.
4. Ensure that none of the wires are stressed, then hand-tighten the gland seals on all the enclosures.
5. A user supplied ground wire should also be connected to the ground lug on the UP CM enclosure to ground per local electrical codes.

Model 6498 Present Weather and Visibility Sensor

Figure 20 shows the inside of the electronics enclosure.

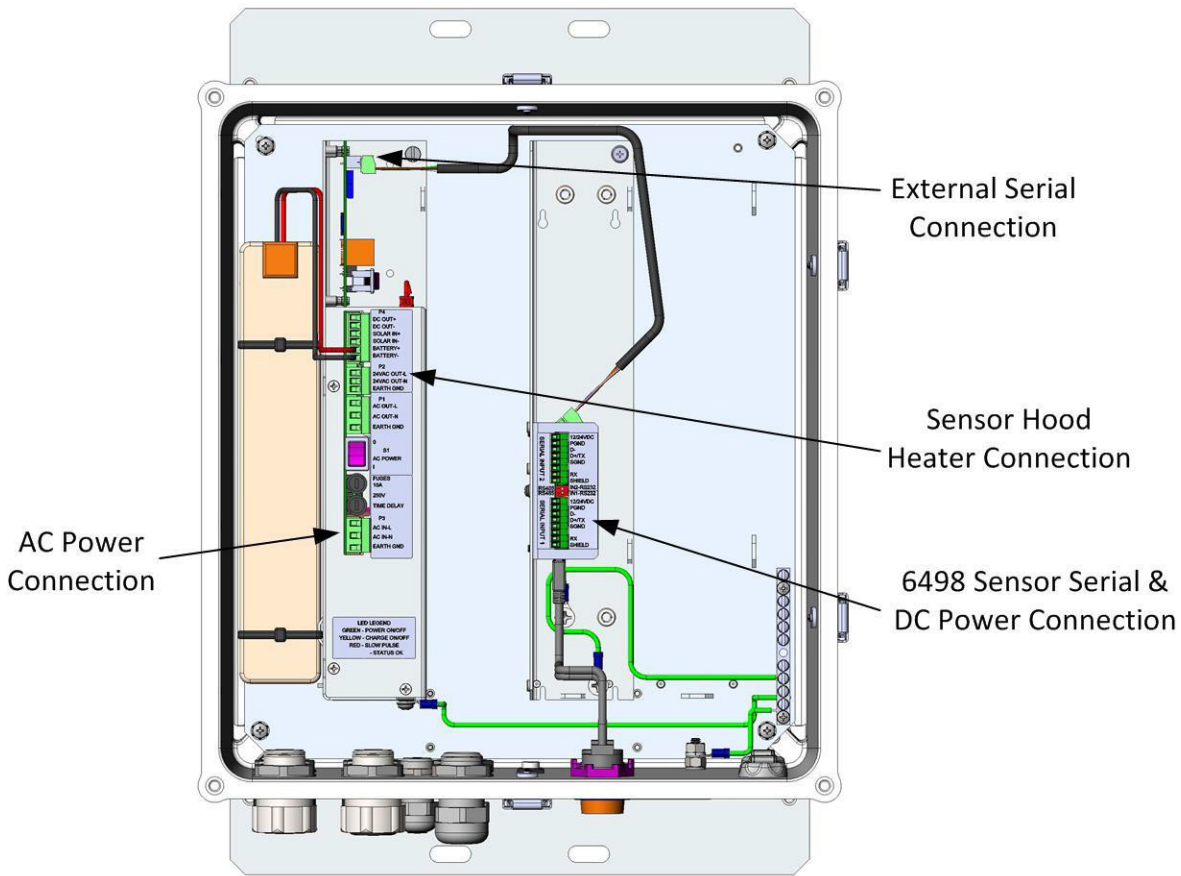

Figure 20. Present Weather and Visibility Sensor Enclosure (inside view)

5.5.2.2 Summary of Signal and Power Wiring Connections (Standalone Sensors)

Table 4 provides the power and serial connections for the 6498 Sensor. The Universal Power and Communication Module may also be configured to provide RS-232 signals for the computer or Data Logger connection to Serial Output 1 (SER0 in the UPCM configuration parameters). See 5.5.3 to change the configuration parameters for Serial Output 1.

Serial Output 2 Pin out (UPCM P7)		Function	Color (to UPCM)	Color (from Sensor)
To Sensor	1	+ 24 V DC	BROWN	RED
	2	GND	GREEN	BLACK
	3	SNS RS-485-	WHITE	WHITE
	4	SNS RS-485+	RED	BLUE
	5	SGND	BLACK	GREEN
	8	GND	SHIELD	
Serial Output 1 Pin out (UPCM P6)		Function*		Color
		RS-232 (option)	RS-485 (default)	Any colors may be used as long as they match the signals on each end of the connection.
To CDP or DCP	3	—	RS-485-	
	4	RS-232 Tx	RS-485+	
	5	SGND	SGND	
	7	RS-232 Rx	—	
	8	SHIELD	SHIELD	
24 V AC Out Pin out (UPCM P2)		Function	Color	
Sensor Heaters	1	LINE	RED	
	2	NEUTRAL	BLACK	
	3	GROUND	SHIELD	
AC Power Pin out (UPCM P3)		Function	Color	
AC Power	1	LINE	BLACK or BROWN	
	2	NEUTRAL	WHITE or BLUE	
	3	GROUND	GREEN	

* The serial output on Serial Output 1 is RS-485 by default, but this may be changed to RS-232 by modifying the firmware configuration file. To change the Serial Output 2 parameters see Section 5.5.3.

Table 4. Model 6498 Present Weather and Visibility Sensor Signal and Power Wiring

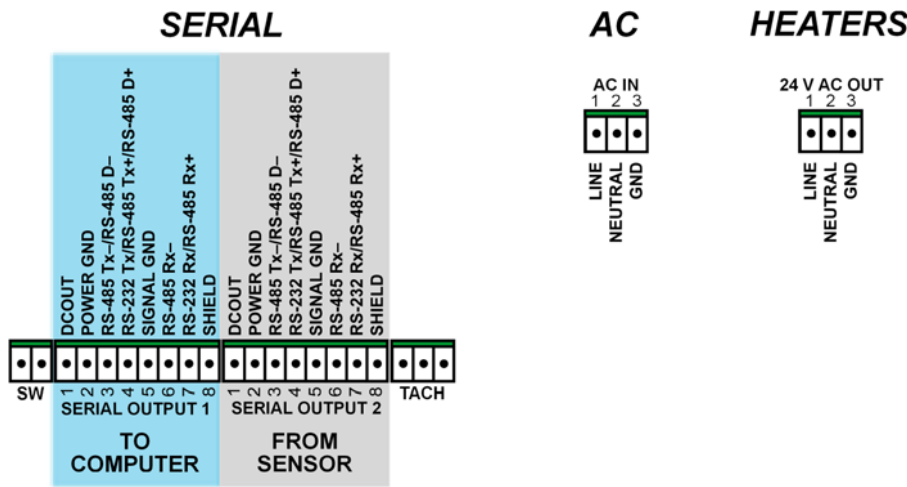

Figure 21. Model 6498 Present Weather and Visibility Sensor Standalone Signal and Power Wiring

Figure 22 shows the signal and power wiring of the Model 6498 Present Weather and Visibility Sensor to the UPCM through the Maintenance Interface Module. *Note that the sensor hood heaters are wired directly to P2, the 24 VAC output on the UPCM.*

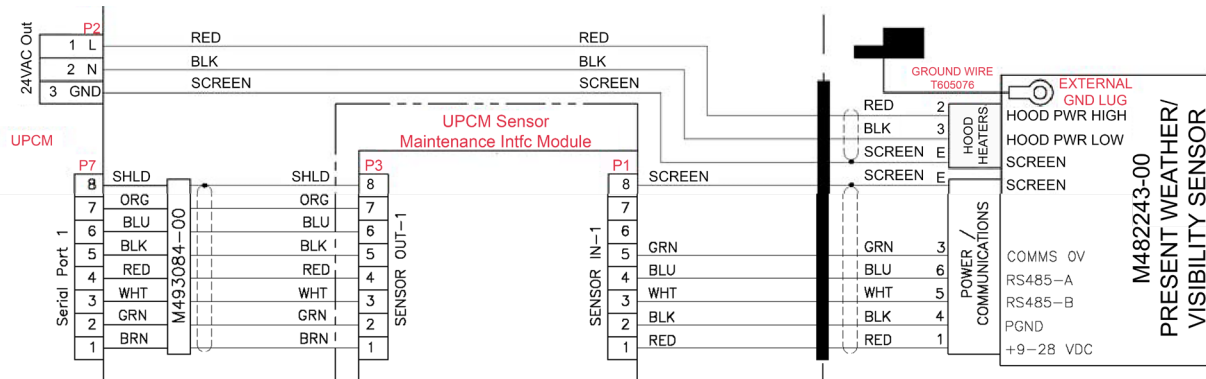

Figure 22. Model 6498 Present Weather and Visibility Sensor Signal Wiring through Maintenance Interface Module

5.5.2.3 Connecting 6498 Sensor to a Computer or Data Logger

1. If the computer serial cable is not already connected to Serial Output 0 on the Universal Power and Communication Module, wire the friction lock connector as shown in Table 4. If the connection to the computer is RS-232 verify the UPCM configuration file has been updated to configure the port for RS-232.
2. Feed the free end of the serial cable through the conduit shown in Figure 19.
3. Strip and tin the ends of the wires.
4. Route the cable and connect it to the computer or data logger interface.

5.5.2.4 Connecting the 6498 Sensor to the AC Power Line

Connections are made to the Universal Power and Communication Module inside the electronics enclosure

AC power connections are made to the Universal Power and Communication Module located inside the electronics enclosure. A 3-wire, single-phase AC source is required consisting of hot, neutral, and earth ground connections.



WARNING

Turn off electrical power at the source before making the electrical connections to the UPCM!

-
1. Install a conduit fitting at the location shown in Figure 19. Feed the power cable through the conduit fitting. A 3-wire 16 to 18 AWG cable is recommended.
 2. Connect a friction lock plug connector to the ends of the wires so that hot, neutral, and ground will be connected shown in Table 4.

5.5.3 Configuring Serial Output 1

To modify the computer data logger interface Serial Output 1 parameters the user must edit the UPCM configuration file. The UPCM configuration file is contained in the UPCM microSD card. The microSD is typically located in the microSD card slot on the UPCM.

If it becomes necessary to change the configuration, contact ADB Safegate., for a microSD card that already has the desired configuration. If it is desired to modify the configuration file locally do the following: remove the existing microSD card, place it in an adapter or a USB microSD card device, and use a computer to edit the configuration file using a text editor such as Notepad. The configuration file name is myfile.txt.

When editing the myfile.txt, edit only the parameters shown in Table 5.



WARNING

If other parameters are changed, the sensor might not function.

Model 6498 Present Weather and Visibility Sensor

This procedure explains how to remove and replace the microSD card containing the configuration file.

1. Turn the DC power supply *off* (DC on/off switch).
2. Remove the microSD card containing the configuration file.
3. Replace the microSD card containing the new configuration file.
4. Turn the DC power supply *on* (DC on/off switch).
5. The status LEDs are above the microSD card slot. The red status LED blinks rapidly (approximately ten times per second) for a few seconds after being powered on. Wait until the red status LED begins to blink slowly (approximately once per second).

If the red status LED does not blink as expected, check the microSD card and reseat the card in the slot.

Parameter	Options
SERO_PROT	Protocol 0 = RS-232 1 = RS-485 Full Duplex 2 = RS-485 Half Duplex
SERO_BAUD	Baud rate 0 = 2400 bps 1 = 4800 bps 2 = 9600 bps 3 = 19200 bps 4 = 38400 bps 5 = 57600 bps 6 = 115200 bps 7 = 1200 bps
SERO_DATA	Data Bits 5, 6, 7, 8, or 9
SERO_PAR	Parity 69 = Even parity 78 = No parity 81 = Odd parity
SERO_STOP	Stop Bits 1 or 2
SERO_TE	Termination 0 = Off 1 = On

Table 5. Serial Output 1 Control Parameters



NOTE

The parameters that start with SERO_ apply to UPCM port labeled Serial Output 1.

6.2 Standalone Sensors

The standalone Model 6498 Present Weather and Visibility Sensor is a polled sensor. Data transfers across the serial interface between the UPCM and the Central Data Processor (CDP) this is implemented by default via serial, ASCII encoded, half duplex, 4800 bps, 8-N-1. The data transfer can be configured to different rates by modifying the UPCM configuration file. The default communication rate is used with the domestic AWOS 3000 where the data are aggregated by a DCP before being sent to the CDP.

There are two types of poll commands for the sensor: a topic poll or a legacy sensor poll.

6.2.1 Topic Poll

A Topic poll is a configurable poll that can gather different types of information in a single poll. For example the poll can be used to gather ALS information or Visibility information or both at the same time. An example of a topic poll is shown below. The topic poll contains a bus address for the UPCM. In this example the bus address is 00. The UPCM bus address can be changed in the UPCM configuration file. The number of topics in the poll is not fixed. To add more topics add a pipe symbol followed by the topic number in the string as shown in the examples below.

This example has four topics.

PWR00TOPIC 652|410|611|612 <CR><LF>

PWR00TOPIC <Topic#>|<Topic#> etc...|<Topic#> <CR><LF>

All of the valid topics that can be polled from the 6498 sensor are shown in Table 6. The definition of the 6498 Visibility Status Word and ALS Status Word (Topic 652 and 457) is shown in Table 7.

Topic	Description	Data
410	Visibility Extinction Coefficient	xxxxx
411	Instant visibility (miles)	xx.xx
416	Instant visibility (meters)	xxxxx
420	Light Luminance (Cd/m ²)	xxxxx
421	Day/Night flag	N — night D — day
457	6498 ALS Status Word	x
611	METAR Code	xxx
612	SYNOP Code	xx
621	Accumulation (mm/h)	xx.xx
652	6498 Visibility Status Word	x

Table 6. 6498 Topics Fields

Data transfers in the sensor-to-computer direction are fixed-format ASCII strings, starting with an equals sign (=) and terminated with a carriage return and line feed (<CR> <LF>). The carrier return and line feed allow the use of printers or terminals in monitoring the data.

Model 6498 Present Weather and Visibility Sensor

The sensor is polled once a second and the current present weather and visibility information is updated. The present weather and visibility information is formulated into the poll response once a poll command is received. The parameters are below the poll response.

The CRC is a 4-character CRC that is calculated as explained in Section 6.3.

=PWR00TOPIC|652=x|410=xxxxx|611=xxx|612=xx<EOT> <CRC> <CR> <LF>

00	UPCM Bus Address
652	6498 Status Word
410	Five-character visibility extinction coefficient calculated from MOR
611	Three-character present weather codes follow the W
612	Two-character present weather codes follow the W
<EOT>	End of Transmission
<CRC>	CRC 4-character hex checksum value for data validation
<CR>	Carriage Return
<LF>	Line Feed

The Status codes, METAR codes, and SYNOP codes used by the sensor output are defined in Table 7, Table 8 and Table 9.

Status	Data
No fault	0
Possible degraded sensor performance	1
Degraded sensor performance	2
Sensor Maintenance Required	3

Table 7. Status Word: Topic 652 and 457

Model 6498 Present Weather and Visibility Sensor

The following SYNOP codes from WMO Table 4680 can be output by the 6498.

00	No significant weather observed	57	Drizzle and rain, slight
04	Haze, smoke, or dust in suspension in the air, visibility \geq 1 km	58	Drizzle and rain, moderate or heavy
05	Haze, smoke, or dust in suspension in the air, visibility < 1 km	60	Rain
10	Mist	61	Rain, not freezing, slight
20	Fog	62	Rain, not freezing, moderate
21	Precipitation	63	Rain, not freezing, heavy
22	Drizzle (not freezing) or snow grains	64	Rain, freezing, slight
23	Rain (not freezing)	65	Rain, freezing, moderate
24	Snow	66	Rain, freezing, heavy
25	Freezing drizzle or freezing rain	67	Rain (or drizzle) and snow , slight
30	Fog	68	Rain (or drizzle) and snow, moderate or heavy
31	Fog or ice fog in patches	70	Snow
32	Fog or ice fog, has become thinner during the past hour	71	Snow, slight
33	Fog or ice fog, no appreciable change during the past hour	72	Snow, moderate
34	Fog or ice fog, has become thicker during the past hour	73	Snow, heavy
35	Fog, depositing rime	74	Ice pellets, slight
40	Precipitation	75	Ice pellets, moderate
41	Precipitation, slight or moderate	76	Ice pellets, heavy
42	Precipitation, heavy	77	Snow grains
45	Solid precipitation, slight or moderate	80	Showers or Intermittent Precipitation
47	Freezing precipitation, slight or moderate	81	Rain shower(s) or intermittent rain, slight
48	Freezing precipitation, heavy	82	Rain shower(s) or intermittent rain, moderate
51	Drizzle, not freezing, slight	83	Rain shower(s) or intermittent rain, heavy
52	Drizzle, not freezing, moderate	84	Rain shower(s) or intermittent rain, violent
53	Drizzle, not freezing, heavy	85	Snow shower(s) or intermittent snow, slight
54	Drizzle, freezing, slight	86	Snow shower(s) or intermittent snow, moderate
55	Drizzle, freezing, moderate	87	Snow shower(s) or intermittent snow, heavy
56	Drizzle, freezing, heavy	89	Hail

Table 8. 6498 SYNOP Codes

Model 6498 Present Weather and Visibility Sensor

SYNOP codes 20–25 are used to report precipitation, fog (or ice fog) at the station during the preceding hour but not at the time of observation.

SYNOP codes 45, 47 & 89 require the M482264-00 Radar Precipitation Detector to be present

The following METAR codes from WMO Table 4678 can be output by the 6498 using the topic poll command.

UP	Unidentified Precipitation	–	Light
HZ	Haze	+	Heavy
BR	Mist	The intensity qualifiers, ‘-’ for light, ‘+’ for heavy, may be added in front of all types.	
FG	Fog		
DZ	Drizzle		
RA	Rain		
SN	Snow		
SG	Snow grains		
PL	Ice pellets		
NSW	No Significant Weather		

Table 9. 6498 – Topic METAR Codes

FZ (freezing) may be added as a descriptor in front of BR and DZ.

Combinations, for example, RASN for rain and snow, may also be reported.

6.2.2 CP Sensor Poll Commands

The DCP sensor poll commands are used by the AWOS 3000 and AWOS 900 Data Collection Platform (DCP). The DCP uses these commands to gather sensor data from the 8364-E Visibility sensor and 6490 Present Weather sensor. The DCP sensor poll commands supported by this sensor are VISI00 and PRWX00. The bus address for these poll commands is permanently fixed at 00.

Since the 6498 sensor supports these commands, it can be used as a direct replacement for the 8364-E Visibility sensor and/or 6490 Present Weather sensor. The 6498 sensor must be enabled at the factory to operate with these poll commands. If the 6498 is only replacing one of these sensors and not both, the 6498 sensor must only be enabled for the command that matches the sensor it is replacing.

6.2.2.1 VISI00 Poll

The VISI00 poll command is the legacy poll command for the 8364-E Visibility sensor.

An example of the VISI00 poll command response is shown below:

```
= 0.15 1048 0000 0001    0 2 1 0 0 0 ECE0
=<VIS> <STAT0> <STAT1> <STAT2> <ALS> <PC> 1 0 0 0 <CRC><CR><LF>
    <VIS>    Visibility Extinction Coefficient in miles
    <STAT0>  Status 0 as defined in Table 10
    <STAT1>  Status 1 as defined in Table 11
    <STAT2>  Status 2 as defined in Table 12
    <ALS>    ALS data value
    <PC>     Packet Counter: counts 0 through 7 and resets
    1 0 0 0  Fixed value
    <CRC>    CRC 4-character hex checksum value for data validation
    <CR>     Carriage Return
    <LF>     Line Feed
```

The CRC is a 4-character CRC that is calculated as explained in Section 6.3.

Status	Data
No fault	0048
Possible degraded sensor performance	1048

Table 10. VISI00 Status 0

Status	Data
No fault	0000
Degraded sensor performance	0003
Sensor maintenance required	000C

Table 11. VISI00 Status 1

Status	Data
Day / Night sensor installed ALS sensor not installed Day / Night sensor sensing day	0009
Day / Night sensor installed ALS sensor not installed Day / Night sensor sensing night	0008
Day / Night sensor not installed ALS sensor not installed	0005
Day / Night sensor not installed ALS sensor installed	0004
Day / Night sensor installed ALS sensor installed Day / Night sensor sensing day	0001
Day / Night sensor installed ALS sensor installed Day / Night sensor sensing night	0000

Table 12. VISI00 Status 2

6.2.2.2 PRWX00 Poll

The PRWX00 poll command is the legacy poll command for the 6490 Present Weather sensor.

An example of the PRWX00 poll command response is shown below:

```
=W P6498S0080 X000L000K000H000T000 110034 98678 161B
=W<PW>P6498S<STAT> X000L000K000H000T000 <EC> <MC> <CRC><CR><LF>
```

W	Fixed values
<PW>	Present Weather Code as defined in Table 13
P6498S	Fixed values
<STAT>	6490 Status as defined in Table 14
X000	Fixed values
L000	Fixed values
K000	Fixed values
H000	Fixed values
T000	Fixed values
<EC>	Error message Counter – Counts up
<MC>	Message Counter – Counts up
<CRC>	CRC 4-character hex check sum value for data validation
<CR>	Carriage Return
<LF>	Line Feed

The CRC is a 4-character CRC that is calculated as explained in Section 6.3.

The following METAR codes can be output by the 6498 using the PRWX00 poll command.

Status	Data
R-	Light Rain
R_	Moderate Rain
R+	Heavy Rain
S-	Light Snow
S_	Moderate Snow
S+	Heavy Snow
P-	Light Precipitation
P_	Moderate Precipitation
P+	Heavy Precipitation
L-	Light Drizzle
L_	Moderate Drizzle
L+	Heavy Drizzle
—	No Precipitation

Table 13. 6498 – PRWX00 METAR Codes

Status	Data
No fault	0000
Possible degraded sensor performance	0080
Degraded sensor performance	4000
Sensor Maintenance Required	0C00

Table 14. PRWX00 Status Byte

6.3 Checksum Calculation

The CRC is calculated using a standard crc-16 formula for both types of poll commands. For reference the algorithm is as follows.

```

/* CRC routine used with AWOS remote sensors USE:   crc = crc16(buffer, length,initial_value)
   where:  crc is the returnedvalue,
           buffer is the data buffer to compute a crc
           length is the number of bytes in buffer to process initial_value
           is the results of previous crc calculations
           that will allow the buffer crc to be computed in stages
           if necessary. If this is not necessary, then set
           initial_value to 0.

*/

unsigned int crc16(char *string, unsigned int length, unsigned int ival)

/* buffer address to compute a crc*/
/* number of characters to process*/
/* initial valueofcrc          */
{

    static unsigned int crc;

    /*   CRC values forcrc16routine          */

    static unsigned int crc_vals[]=
    {
        0x0000,0xc0c1,0xc181,0x0140,0xc301,0x03c0,0x0280,0xc241,
        0xc601,0x06c0,0x0780,0xc741,0x0500,0xc5c1,0xc481,0x0440,
        0xcc01,0x0cc0,0x0d80,0xcd41,0x0f00,0xcfc1,0xce81,0x0e40,
        0x0a00,0xcac1,0xcb81,0x0b40,0xc901,0x09c0,0x0880,0xc841,
        0xd801,0x18c0,0x1980,0xd941,0x1b00,0xdbc1,0xda81,0x1a40,
        0x1e00,0xdec1,0xdf81,0x1f40,0xdd01,0x1dc0,0x1c80,0xdc41,
        0x1400,0xd4c1,0xd581,0x1540,0xd701,0x17c0,0x1680,0xd641,
        0xd201,0x12c0,0x1380,0xd341,0x1100,0xd1c1,0xd081,0x1040,
        0xf001,0x30c0,0x3180,0xf141,0x3300,0xf3c1,0xf281,0x3240,
        0x3600,0xf6c1,0xf781,0x3740,0xf501,0x35c0,0x3480,0xf441,
        0x3c00,0xfcc1,0xfd81,0x3d40,0xff01,0x3fc0,0x3e80,0xfe41,
        0xfa01,0x3ac0,0x3b80,0xfb41,0x3900,0xf9c1,0xf881,0x3840,
        0x2800,0xe8c1,0xe981,0x2940,0xeb01,0x2bc0,0x2a80,0xea41,
        0xee01,0x2ec0,0x2f80,0xef41,0x2d00,0xedc1,0xec81,0x2c40,
        0xe401,0x24c0,0x2580,0xe541,0x2700,0xe7c1,0xe681,0x2640,
        0x2200,0xe2c1,0xe381,0x2340,0xe101,0x21c0,0x2080,0xe041,
        0xa001,0x60c0,0x6180,0xa141,0x6300,0xa3c1,0xa281,0x6240,
        0x6600,0xa6c1,0xa781,0x6740,0xa501,0x65c0,0x6480,0xa441,
        0x6c00,0xacc1,0xad81,0x6d40,0xaf01,0x6fc0,0x6e80,0xae41,
        0xaa01,0x6ac0,0x6b80,0xab41,0x6900,0xa9c1,0xa881,0x6840,
        0x7800,0xb8c1,0xb981,0x7940,0xbb01,0x7bc0,0x7a80,0xba41,
        0xbe01,0x7ec0,0x7f80,0xbf41,0x7d00,0xbdc1,0xbc81,0x7c40,
        0xb401,0x74c0,0x7580,0xb541,0x7700,0xb7c1,0xb681,0x7640,
        0x7200,0xb2c1,0xb381,0x7340,0xb101,0x71c0,0x7080,0xb041,
        0x5000,0x90c1,0x9181,0x5140,0x9301,0x53c0,0x5280,0x9241,
        0x9601,0x56c0,0x5780,0x9741,0x5500,0x95c1,0x9481,0x5440,
        0x9c01,0x5cc0,0x5d80,0x9d41,0x5f00,0x9fc1,0x9e81,0x5e40,
        0x5a00,0x9ac1,0x9b81,0x5b40,0x9901,0x99c0,0x5880,0x9841,
        0x8801,0x48c0,0x4980,0x8941,0x4b00,0x8bc1,0x8a81,0x4a40,
        0x4e00,0x8ec1,0x8f81,0x4f40,0x8d01,0x4dc0,0x4c80,0x8c41,
        0x4400,0x84c1,0x8581,0x4540,0x8701,0x47c0,0x4680,0x8641,
        0x8201,0x42c0,0x4380,0x8341,0x4100,0x81c1,0x8081,0x4040};
    }
}

```

Model 6498 Present Weather and Visibility Sensor

```
crc = ival;
while(length--)
    crc = crc_vals[( *string++ ^ crc) & 0xff] ^ ((crc >> 8) & 0xff); return
    crc;
}

/* end crc16 routine */
```

7. Maintenance And Troubleshooting

The maintenance and troubleshooting activities in this chapter are intended to be performed by trained technicians certified to maintain the AWOS 3000 and/or its associated sensors.

Equipment Required

- Clean Cotton Cloth or Lens Tissue (monthly)
- Common Household GlassCleaner (monthly)
- Anti-seize grease (annual)

7.1 Monthly Maintenance

1. Check Lens Heaters

With a clean finger, touch the lenses in front of the disc-shaped heaters, which are bonded to the upper and lower inside surface of lenses. The lens surfaces should be slightly warmer to the touch than the ambient temperature.

2. Clean Lenses

The lens cleaning should be done with lint-free cloth and cleaning solution. Clean the lenses by first spraying the lens cleaner on the lens and then wipe gently to prevent scratching the glass optics. In actual practice, moderate dust buildup and scratches on the lenses will not have any discernible effect on the instrument.

7.2 Triannual Maintenance

In addition to the monthly maintenance, check the status display on the MetObserver diagnostic screen for the Present Weather and Visibility Sensor.

If a failure occurs, the status will be shown in **RED**.

7.3 Annual Maintenance

1. Perform a calibration after the monthly and triannual procedures have been completed.
2. Verify the operation of the Day/Night Sensor by accessing the Setup Menu as described in Sections 8.1 and 8.2 Enter ADB Safegate instead of the numbers shown in Step 2 in Section 8.2 and press Enter, then type 10 and press Enter on the screen that appears to access Menu 10, the ADB Safegate menu. The status of the Day/Night Sensor will appear between lines 6 and 9.

When the 6498 is connected to an AWOS, the status of the Day/Night Sensor may also be checked using the DCP status screens.

- Cover the Day/Night Sensor. After approximately two minutes, check the screen showing the status of the Day/Night Sensor. Verify that the screen indicates "Night."
- Remove the cover from the Day/Night Sensor and verify that the screen indicates "Day" after approximately two minutes.

7.4 Trouble Shooting

The troubleshooting action response to the four levels of sensor status is shown in Table 15.

Status	Troubleshooting Action
No fault	No action required.
Possible degraded sensor performance	Check the sensor heads for insects, insect nests or spiders. Clean the transmitter and receiver tubes.
Degraded sensor performance	Check the sensor head for insects, insect nests or spiders. Clean the transmitter and receiver tubes.
Sensor Maintenance Required	Check the sensor heads for any obvious obstructions to the sensor optical path. The sensor will need to be return to the factory to be repaired.

Table 15. Troubleshooting Status

8. Calibration

The ideal conditions to calibrate the sensor are as follows.

- Ambient temperature should be between 0°C and 50°C (32°F to 122°F)
- Visibility at least 10 km (7 miles)

In the event that the ambient air temperature is outside this range, an offset equation can be used as described in Step 7, Section 8.2.

The following resources are required to calibrate the Model 6498 Present Weather and Visibility Sensor.

- Calibration Paddle (“calibrator” included in M482254-00 Calibration Kit)
- Calibration Blocks (“bungs” included in M482254-00 Calibration Kit)
- Computer with terminal emulation utility such as TeraTerm
- Cable
 - o USB A/B cable for standalone sensors
 - o CAT 5/6 cable for Direct Connect sensors

8.1 Connections

8.1.1 Direct Connect Sensors

This section explains how to use the built-in features of the Model 1192 Data Collection Platform to perform visibility calibrations for the 6498-DC series of Present Weather/Visibility sensors. *Note that these instructions apply only to the Direct Connect sensors, which have DC in their model number.*

1. Connect a laptop to the DCP using a standard CAT5/6 cable. (Administrator access is required to perform the steps in this procedure.)
 2. Navigate to the Control Panel > *Network and Sharing Center* and then click on **Change Adapter settings**.
 3. Right-click on the network adapter connected to the DCP and click **Properties**.
 4. Select **Internet Protocol Version 4 (TCP/IPv4)** and click **Properties**.
 5. Enter the information shown here.
IP Address: 192.168.5.20
Subnet mask: 255.255.255.0
Default gateway: 192.168.5.1
DNS information can be left blank.
- Click **OK**.
6. Click **Close**.
 7. Open a terminal emulation utility such as PuTTY on the test computer.
 8. Enter 192.168.5.5 for the host name and 3107 for the port.

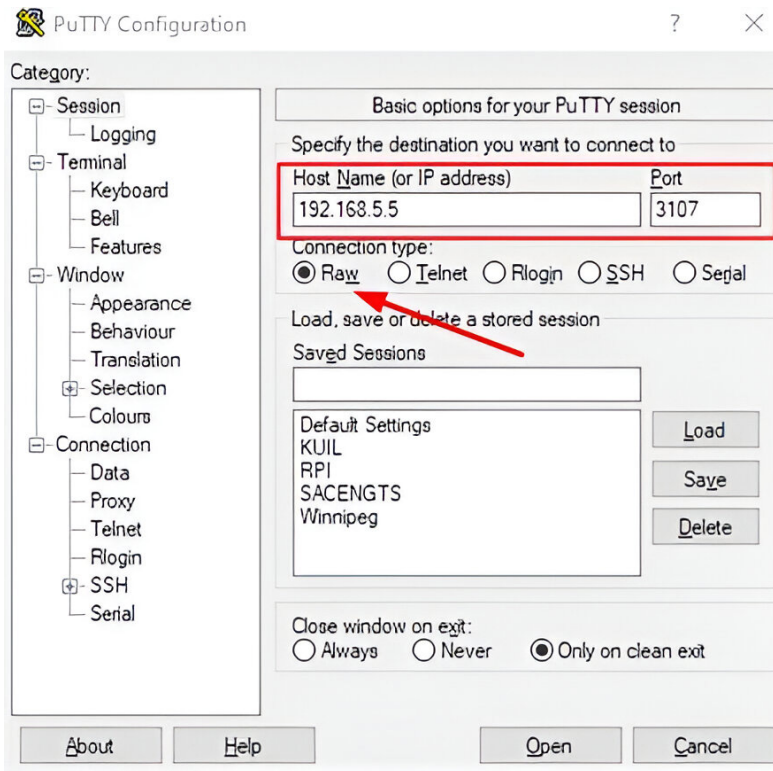

The screenshots were obtained using PuTTY v 0.71 on a Windows 10 computer. Other terminal emulation utilities and operating systems may be used. Please contact ADB Safegate Customer Service for additional assistance if needed.

- Click on Terminal in the list on the left and set Local echo to **Force off** and Local line editing to **Force off**.

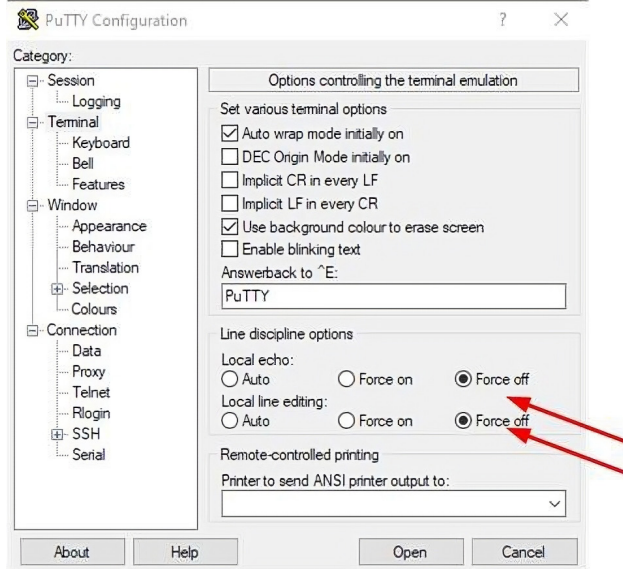

- Click Open. The 6498 setup menu will appear.

8.1.2 Standalone Sensors

If the computer being used to perform the calibration has not been used before for this purpose, you must download the USB drivers from <https://www.ftdichip.com/Drivers/VCPh.htm>. Click on the Windows or Mac OS version, depending on the operating system, for the processor architecture on your computer; select the 64-bit architecture if you are unsure. Follow the instructions provided with the driver download to install the driver,

Currently Supported VCP Drivers:

Operating System	Release Date	x86 (32-bit)	x64 (64-bit)
Windows*	2017-08-30	2.12.28	2.12.28
Linux	-	-	-
Mac OS X 10.3 to 10.8	2012-08-10	2.2.18	2.2.18
Mac OS X 10.9 and above	2020-08-13	-	2.4.4

Model 6498 Present Weather and Visibility Sensor

1. Connect one of the computer's USB ports to the Sensor 1 maintenance port on the bottom side of the enclosure (see Figure 19).
2. Identify the COM port related to the USB cable connection on the computer. To identify the COM port related to a USB cable in a computer running Windows 7 or 10, open the Device Manager located in the Control Panel. Go to the Ports (COM & LPT) area and expand the tree. Unplug the USB cable, wait for 30 seconds or so, and then plug the USB cable back in. A communications port will appear in the device manager when the USB cable is connected. This is the communications port directly related to the USB cable.
3. Open a terminal emulation utility such as TeraTerm and select the serial COM port related to the USB cable.
4. Set up the terminal emulation utility serial port as follows

Baud Rate: 38400

Data Bits: 8

Parity: None

Stop Bits: 1

Flow Control: None

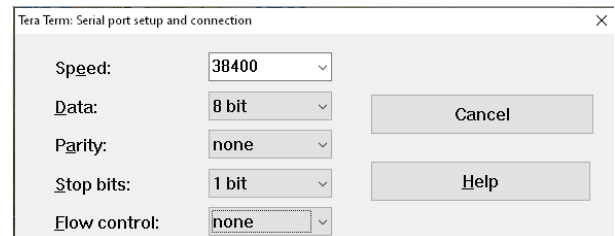

5. Click **OK**
6. Set Transmit in the Terminal Setup to CR+LF. Leave Local echo unchecked.

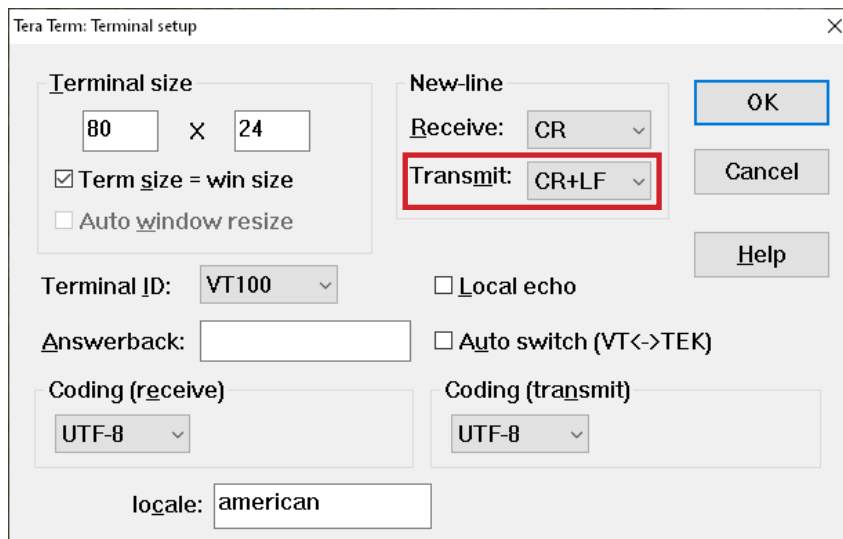

7. Click **OK**. The 6498 setup menu will appear.

8.2 Calibration Procedure

The calibration is performed using the onboard menu system.

1. Type the following command in the terminal emulation utility and click **Enter** to access the menus.

open 0



NOTE

The "0" corresponds to the Sensor ID number. The sensor ID is always 0 for the 6498 sensor.

2. The setup menu should now be displayed. If the menu does not appear, check the terminal emulation utility settings, then type the command again.



NOTE

If the sensor does not answer to "open 0", poll all of the other sensor IDs. To poll the other IDs type "open 1" press enter, then type "open 2" and repeat until you reach "open 9". If the sensor answers to a sensor ID other than 0 the sensor ID should be changed to 0. If the sensor ID is set to the wrong ID it will not answer to open 0.

```
WELCOME TO THE ADB Safegate 6498 SETUP MENU ID 0
S/N 1003
(1) Message output menu
(2) User alarm menu
(3) Calibrate ADB Safegate 6498
(4) System information
(5) Communications setup
(6) System configuration

(9) Exit and save
(0) Exit and don't save
->
```

3. If there is no record of the previous calibration values, and this is not the first calibration being done, type 4 to access the system information and write down the *Scale Change* and the *Offset Change*. Type 0 to return to the main menu.
4. Type 3 to access the calibration menu. The following text should now be displayed

```
CALIBRATION - MENU 3 ID 0
S/N 1009
(1) Perform calibration
(2) Restore the factory calibration
(3) Perform dirty windows zero offset calibration
(4) Restore dirty windows factory calibration
(9) Refresh
(0) Return to main menu
```

Model 6498 Present Weather and Visibility Sensor

5. Type 1 to start the calibration. You will then be asked to confirm that you would like to perform a calibration.

Do you want to perform a calibration Y/N?

6. Type Y to start the calibration. *You do not have to press return.* Once you have entered yes at this point, you will not be able to exit until the test is complete. However, power cycling the unit at this point will have no adverse effect on the sensor.
7. Once you have started the tests, you will be asked for the calibrator serial number and calibrator constant with a confirmation at each step giving you the chance to correct typing mistakes.

If the ambient temperature at which the calibration is being performed is not between 0°C and 50°C, adjust the calibrator constant, σ , of the calibrator using the following equation, where T is the ambient temperature in degrees Celsius, to get σ_T , the calibrator constant at the current ambient temperature.

$$\sigma_T = \sigma - 0.001(20 - T)\sigma$$

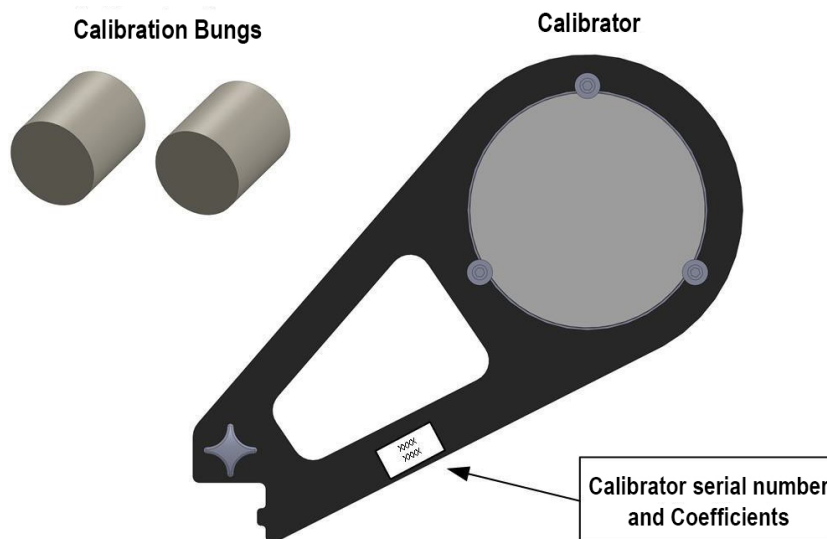

Figure 23. 6498 Calibration Equipment

```
CALIBRATION - MENU 3
Starting calibration.
Input the calibrator serial number ->12345
Is 12345 correct? (Y/N)?
Input the calibrator constant ->10000
Is 10000 correct? (Y/N)?
Place one calibration bung into each hood, then
press any key.
```

- When you have entered the calibrator information, the sensor will wait for you to place the calibration blocks/bungs into the sensor hoods. These inserts are designed to block all light from the outside reaching inside the head. Place one insert into each hood. If either of the inserts is damaged or appears to have any gaps around the edge, please contact ADB Safegate.

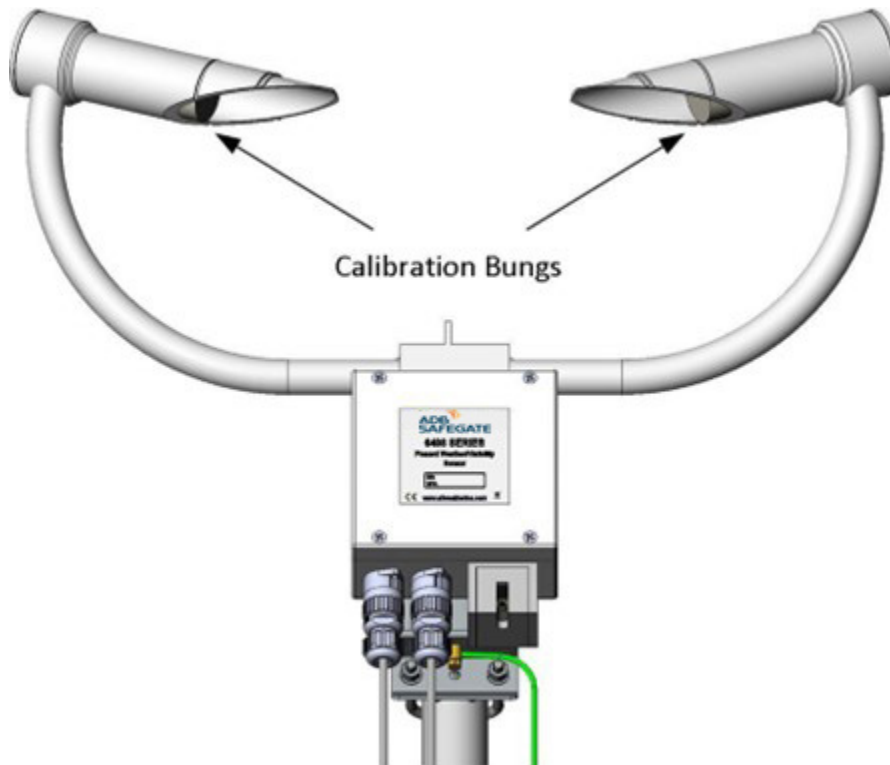

Figure 24. 6498 with the Calibration Blocks/Bungs installed

- Press any key once the calibration blocks/bungs are in place.

Starting dark level calibration.
This test will take approximately two minutes

- This part of the test will take approximately two minutes. Every ten seconds a dot should appear, indicating that the test is progressing as normal. The message below appears once this test has been completed.

Dark level test complete. Please remove the bungs.
Now place the calibrator into the sampling volume.
Press any key once this is done.

11. Remove the blocks/bungs once the sensor instructs you to. Place the calibrator into the volume by fastening it to the central mounting point.



NOTE

This is also a good time to clean the lenses or at least verify they are clean

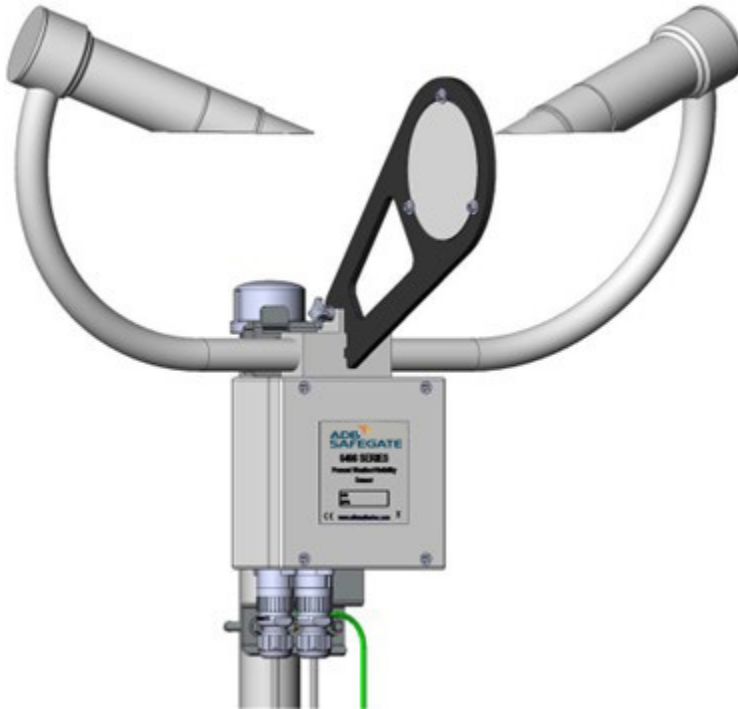

Figure 25. 6498 with the Calibrator installed

12. Press any key once the calibrator is in place and the lenses are clean

Starting light level calibration.
This test will take approximately two minutes.

13. This part of the test will take approximately two minutes. Every ten seconds a dot should appear, indicating that the test is progressing as normal. The message below appears once this test has been completed.

Calibration is now complete.
Saving user settings
Press any key to exit.

14. Press any key to exit.

- Once the test has been completed, the new calibration values are saved automatically. Both the factory and the saved calibration values can be viewed from menu item 4 from the main menu once the test is completed

```

ADB Safegate INFORMATION - MENU 4
ID 0
S/N 3051
OS version: 007648v3           Alarm   Value
- Last visibility reading:     -       63004M
- Overall system status:       0       No faults
.
.
.
- ADB Safegate 6498 Calibrator Serial No: -       2000
- ADB Safegate 6498 Calibrator Constant: -       23.7
- Calibration value Fac offset: -       -0.004
- Calibration value Fac scale: -       0.02099
- Calibration value Cal offset: -       -0.004
- Calibration value Cal scale: -       0.02099
.
.
.
(8) Get debug
(9) Refresh
(0) Return to main menu
->
    
```

- View and record the new saved calibration values if needed for analysis or for an inspection record.
- Remove the calibrator, close the terminal emulation utility, and disconnect the computer. If you had to remove a cover to access the maintenance port, replace the cover.

8.2.1 Analyzing the Calibration Values

Calibration values are analyzed by comparing them with the values recorded previously or with the factory values if the calibration is being done for the first time.

$$Scale\ Change = \frac{Old\ Scale\ Value - New\ Scale\ Value}{Old\ Scale\ Value} \times 100\%$$

$$Offset\ Change = New\ Offset\ Value - Old\ Offset\ Value$$

Validity

Determine whether the saved calibration values are valid.

- The calibration is valid if the *Scale Change* is less than 3% and the *Offset Change* is less than 0.05.
- Record the *Scale Change* and the *Offset Change* and repeat the calibration if either the ***Scale Change*** or the ***Offset Change*** is greater than these values.
- Check the following before repeating the calibration.
 - Verify the lenses have been cleaned
 - Perform the Dirty Window Zero Calibration (Section 8.3) if this has not been done in the last two years
 - Verify visibility is > 10 km
 - Verify that the calibrator constant, σ has been corrected for temperature if the outside temperature is not between 0°C and 50°C
- Repeat the calibration and check whether the new calibration is valid using the *Scale Change* and the *Offset Change* recorded in Step 2 as the old values in the change equations.
- Record the *Scale Change* and the *Offset Change* values used to determine validity if needed for an inspection record.

Sensor Ageing

Assess whether the sensor is ageing normally. Calculate the *Scale Change* and the *Offset Change* values by using the values from the previous inspection as the old values in the change equations.

The sensor is ageing normally if the annual *Scale Change* is less than 5% and the *Offset Change* is less than 0.1.

Record the *Scale Change* and the *Offset Change* values used to determine sensor ageing if needed for an inspection record.

- Contact ADB Safegate, if the ageing calculation *Scale Change* is more than 5% or the *Offset Change* is more than 0.1.
- The *Calibration Offset* (shown as Cal Offset) should be less than 0.3. Contact ADB Safegate, if the *Calibration Offset* is above 0.3.

8.3 Dirty Window Zero Calibration

The opacity of the sensor optics and the output of the infrared LEDs change with time. The “Dirty Window Zero Calibration” in this section should be carried out every two years to check for any slight drift in what would otherwise be considered a dirty window detection or when there are issues when determining that the calibration in Section 8.2 was valid.

Make sure the lenses are as clean as possible before performing this calibration. The temperature should ideally be in the range 15 – 30°C and the sensor should have been powered up for over 5 minutes.

- For *Direct Connect sensors*, connect the computer to the DCP using a standard CAT5/6 cable as explained in Section 8.1.1.
- For standalone sensors, connect one of the computer’s USB ports to the Sensor 1 maintenance port on the bottom side of the enclosure as explained in Section 8.1.2.

The calibration is performed using the onboard menu system.

1. Type the following command in the terminal emulation utility and click Enter to access the menus.

```
open 0
```



NOTE

The “0” corresponds to the Sensor ID number. The sensor ID is always 0 for the 6498 sensor.

2. The setup menu should now be displayed. If the menu does not appear, check the terminal emulation utility settings, then type the command again.



NOTE

If the sensor does not answer to “open 0”, poll all of the other sensor IDs. To poll the other IDs type “open 1” press enter, then type “open 2” and repeat until you reach “open 9”. If the sensor answers to a sensor ID other than 0 the sensor ID should be changed to 0. If the sensor ID is set to the wrong ID it will not answer to open 0.

```
WELCOME TO THE ADB Safegate 6498 SETUP MENU
ID 0
S/N 1003
(1) Message output menu
(2) User alarm menu
(3) Calibrate ADB Safegate 6498
(4) System information
(5) Communications setup
(6) System configuration

(9) Exit and save
(0) Exit and don't save
->
```

Model 6498 Present Weather and Visibility Sensor

- Type 3 to access the calibration menu. The following text should now be displayed.

```
CALIBRATION - MENU 3
ID 0
S/N 1009
(1) Perform calibration
(2) Restore the factory calibration
(3) Perform dirty windows zero offset calibration
(4) Restore dirty windows factory calibration
(9) Refresh
(0) Return to main menu
```

- Type 4 to access the dirty windows zero offset calibration menu. The following text should now be displayed.

```
Current values E0=3200 D0=4649 DD=995
Cal DW offset? Y/N?
```

- Type Y. The sensor response should be similar to the following

```
Calibrating dirty window system...Please wait
DD=990 D0=4535
DD=1000 D0=4531
DD=1010 D0=4373
DD=1020 D0=4206
DD=1030 D0=3886
DD=1110 D0=2675
DD=1120 D0=2682
DD=1130 D0=2530
DD=1140 D0=2392
E0=3230 ES=371 D0=2251 DS=234 DD=1140
Press any key to exit (Not return)
```

- Press any key to complete the dirty window zero offset calibration.

9. Accessories

Either a Day/Night Sensor or a Background Luminance Sensor must be used with the Model 6498 Present Weather and Visibility Sensor to provide the most accurate possible visibility readings.

- Day/Night Kit (M403326-01)
- Battery Backup Kit (M438130-00)
- ALS Kit (M488600-00)

9.1 Day/Night Sensor Kit

A Day/Night Sensor Kit (M403326-01) is used to adjust visibility readings for day and night conditions. The sensor mounts to the bottom of the 6498 Present Weather and Visibility Sensor head assembly enclosure. The day and night information is used in AWOS installations, where separate algorithms are used for calculating daytime and nighttime visibility. The Day/Night sensor does not function as an independent sensor. The Day/Night sensor algorithm and set points are controlled by the 6498 Present Weather and Visibility Sensor head control board.

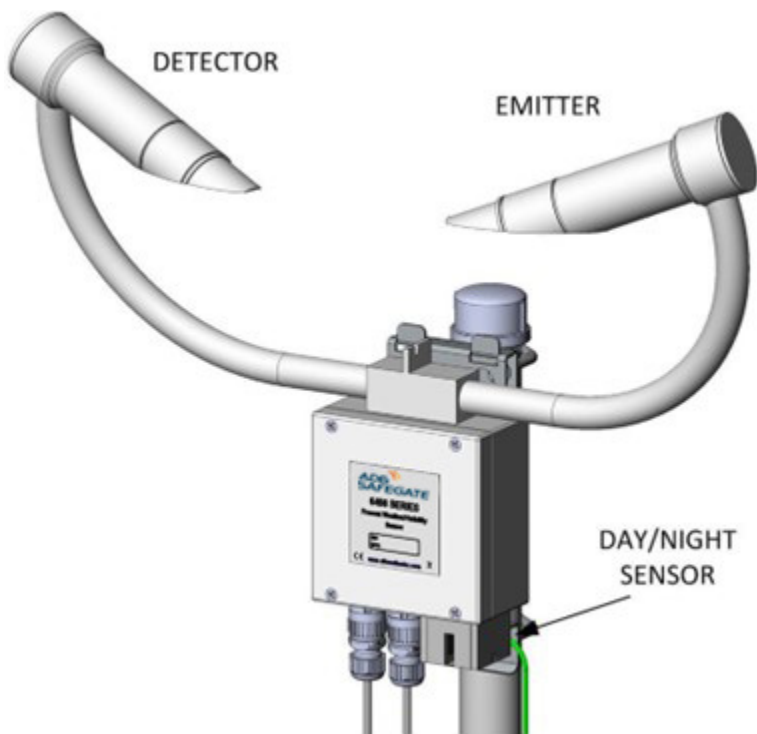

Figure 26. 6498 with the Day / Night Sensor

The Day/Night sensor senses ambient light and reports the existing day or night state. Day is reported when the ambient light intensity is above 29 lux (2.7 foot-candles). Night is reported when the ambient light intensity falls below 7.5 lux (0.7 foot-candles). The day/night set points are calibrated at the factory. The default settings may be changed upon request.

The Day/Night sensor senses ambient light using a photodiode detector, which converts light energy into an electrical current. A 10 W heater is built into the sensor to prevent condensation or ice buildup on the photodetector lens. The heater is controlled by a temperature sensor located in the arm of the sensor head.

The Day/Night sensor is calibrated at the factory with the 6498 Present Weather and Visibility Sensor head. If the Day/Night sensor is replaced, the 6498 sensor head must be returned to the factory to be re-calibrated for the replacement sensor.

9.1.1 Specifications

Parameter	Specification
Sensing Element	Photodiode
Night Activation	$<7.5 \pm 1.6$ lux
Day Activation	$>29 \pm 2$ lux
Temperature Range	-40 to +60°C (-40 to +140°F)
Size	5.08 cm × 5.08 cm × 4.00 cm (2.00" × 2.00" × 1.58")

9.2 Background Luminance Sensor Kit

An optional Background Luminance Sensor Kit (M488600-00) is available for use in calculating visibility and Runway Visual Range (RVR). The Background Luminance Sensor is also known as the Ambient Light Sensor (ALS). The Background Luminance Sensor measures the background luminance of a six degree field of view. The Background Luminance Sensor is mounted horizontally, with the recommended 6° inclination above the horizon. Although the sensor will not be damaged when pointed directly at the sun, it is recommended that it be oriented as much as possible to avoid the sun or any unrepresentative bright lights shining directly at the sensor.

The sensor mounts just below the 6498 Present Weather and Visibility Sensor heads. The sensor functions as an independent sensor and does not require the Present Weather and Visibility Sensor head.

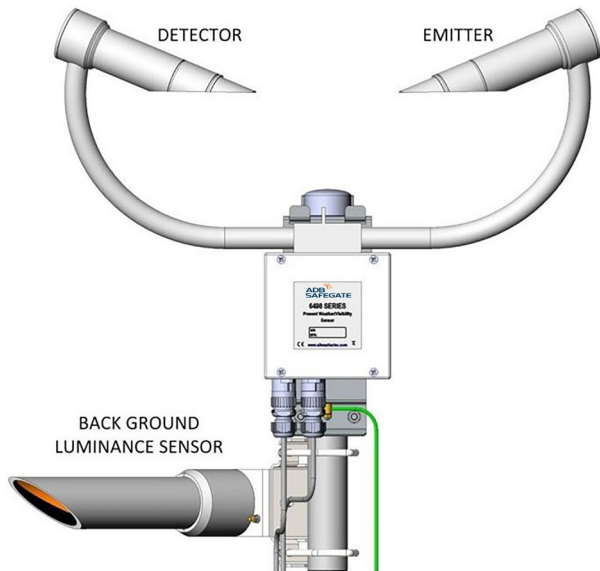

Figure 27. 6498 with the Background Luminance Sensor

- For standalone sensors, the Background Luminance Sensor must be set to the same communications protocol as the 6498 Present Weather and Visibility Sensor head when they are connected to the same 2715 Universal Power and Communication Module. The sensor data is integrated into a single data stream through the 2715 Universal Power and Communication Module located in the electronics enclosure. The sensor data can be accessed using the *Topics polls* as described in Section 6.2.1.
- For *Direct Connect* sensors, the Background Luminance Sensor power and signal wires are routed to the Model 1192 DCP and are connected to the same PWX/VIS terminal block as the sensor heads (as shown in “Figure 18”). The ground lug on the Background Luminance Sensor must also be connected to the ground rod near the base of the mast (as shown in Figure 14).

9.2.1 Specifications

Parameter	Specification
Sensing Element	Photodiode
Accuracy	±10%
Field of View	6°
Spectral Response	CIE 1931
Measurement Range	5 cd/m ² to 45,000 cd/m ²
Operating Temperature Range	-40 to +70°C (-40 to +158°F)
Storage Temperature Range	-40 to +85°C (-40 to +185°F)
Relative Humidity	0–100%, noncondensing
Mounting	Vertical pole with a diameter of 3.2–5.25 cm (1.3"–2.0")
Size	3.5" × 7.0" × 14" (9.0 cm × 18.0 cm × 36.0 cm)
Weight	3 kg (7 lb)

10. Specifications

Parameter	Specification	
SYNOP Codes Reported	Per WMO Table 4680	
METAR Codes Reported	Per WMO Table 4678	
NWS Codes Reported	L, R, S, SG	
Precipitation Detection Sensitivity	0.05 mm/h	
Visibility Measuring Range	0.005–75 km	
Visibility Resolution	1 m	
Visibility Accuracy	±8% up to 600 m ±10% 600 m to 10 km ±15% 10–15 km ±20% above 15 km	
LED Center Wavelength	850 nm	
LED Spectral Bandwidth	±35 nm	
Pulse Rate	1 kHz	
Serial Data	Standalone Models	
Data Update Rate	Polled or Auto Output	
Serial Output	RS-485 (half duplex), may be configured for RS-232 or RS-485 (full duplex)	
Output Format	ASCII characters	
Baud Rate	4800 bps default (1200, 2400, 9600, 19200, 38400, 57600, and 115200 bps configurable)	
Serial Port Parameter Setting	8-N-1 (8 data bits, no parity, 1 stop bit) (configurable)	
Serial Data	Direct Connect Models	
Data Update Rate	Polled	
Serial Output	RS-485 (half duplex)	
Output Format	ASCII characters	
Baud Rate	38400 bps	
Serial Port Parameter Setting	8-N-1 (8 data bits, no parity, 1 stop bit)	
Power Requirements	Standalone Models	Direct Connect Models
Supply Voltage	115/230 V AC, 50/60 Hz, 200 V•A	Sensor 24 V DC, 100 mA Hood Heaters 24 VAC, 60 W
Transient Protection	AC power and serial signal lines fully protected	

Model 6498 Present Weather and Visibility Sensor

Parameter	Specification
Environmental	
Operating Temperature	-40 to +70°C (-40 to +158°F)
Storage Temperature	-40 to +85°C (-40 to +185°F)
Operating Wind Speed	Max. 60 m/s
Relative Humidity	0–100%, noncondensing
Mechanical	
Sensor Sealing	IP66 (NEMA 4X)
Mounting	32.0–52.5 mm dia. mast coupling
Dimensions (Sensor Head Enclosure)	447 mm H × 640 mm W × 245 mm D (17.6" H × 25.2" W × 9.6"D)
Weight (Sensor Head Enclosure)	3 kg (6.5 lb)
Shipping Weight (Sensor Head Enclosure)	6 kg (13 lb)

11. Warranty

Any defect in design, materials, or workmanship which may occur during proper and normal use during a period of 1 year from date of installation or a maximum of 2 years from shipment will be corrected by repair or replacement by ADB Safegate.

Optimizing Airside Operations From approach to take-off

SMARTER. BETTER. **NOW.**

**ADB
SAFEGATE**
www.adbsafegate.com