



AGSB-L LED Airfield Guidance Sign

ICAO/TP 312

Spare Parts List

SP-3060, Rev. G, 2025/08/28

**ADB
SAFEGATE**

A.0 Disclaimer / Standard Warranty

CE certification

The equipment listed as CE certified means that the product complies with the essential requirements concerning safety and hygiene. The European directives that have been taken into consideration in the design are available on written request to ADB SAFEGATE.

ETL certification

The equipment listed as ETL certified means that the product complies with the essential requirements concerning safety and C22.2 No.180:13 (R2018) regulations. The CSA directives that have been taken into consideration in the design are available on written request to ADB SAFEGATE.

All Products Guarantee

ADB SAFEGATE will correct by repair or replacement per the applicable guarantee below, at its option, equipment or parts which fail because of mechanical, electrical or physical defects, provided that the goods have been properly handled and stored prior to installation, properly installed and properly operated after installation, and provided further that Buyer gives ADB SAFEGATE written notice of such defects after delivery of the goods to Buyer. Refer to the Safety section for more information on Material Handling Precautions and Storage precautions that must be followed.

ADB SAFEGATE reserves the right to examine goods upon which a claim is made. Said goods must be presented in the same condition as when the defect therein was discovered. ADB SAFEGATE further reserves the right to require the return of such goods to establish any claim.

ADB SAFEGATE's obligation under this guarantee is limited to making repair or replacement within a reasonable time after receipt of such written notice and does not include any other costs such as the cost of removal of defective part, installation of repaired product, labor or consequential damages of any kind, the exclusive remedy being to require such new parts to be furnished.

ADB SAFEGATE's liability under no circumstances will exceed the contract price of goods claimed to be defective. Any returns under this guarantee are to be on a transportation charges prepaid basis. For products not manufactured by, but sold by ADB SAFEGATE, warranty is limited to that extended by the original manufacturer. This is ADB SAFEGATE's sole guarantee and warranty with respect to the goods; there are no express warranties or warranties of fitness for any particular purpose or any implied warranties of fitness for any particular purpose or any implied warranties other than those made expressly herein. All such warranties being expressly disclaimed.

Standard Products Guarantee

Products manufactured by ADB SAFEGATE are guaranteed against mechanical, electrical, and physical defects (excluding lamps) which may occur during proper and normal use for a period of two years from the date of ex-works delivery, and are guaranteed to be merchantable and fit for the ordinary purposes for which such products are made.



Note

See your applicable sales agreement for a complete warranty description.

Replaced or repaired equipment under warranty falls into the warranty of the original delivery. No new warranty period is started for these replaced or repaired products.

FAA Certified products manufactured by ADB SAFEGATE

ADB SAFEGATE L858 Airfield Guidance Signs are warranted against mechanical and physical defects in design or manufacture for a period of 2 years from date of installation, per FAA AC 150/5345-44 (applicable edition).

ADB SAFEGATE LED products (with the exception of obstruction lighting) are warranted against electrical defects in design or manufacture of the LED or LED specific circuitry for a period of 4 years from date of installation, per FAA EB67 (applicable edition). These FAA certified constant current (series) powered LED products must be installed, interfaced and powered with and through products certified under the FAA Airfield Lighting Equipment Program (ALECP) to be included in this 4 (four) year warranty. This includes, but is not limited to, interface with products such as Base Cans, Isolation Transformers, Connectors, Wiring, and Constant Current Regulators.



Note

See your sales order contract for a complete warranty description.

Replaced or repaired equipment under warranty falls into the warranty of the original delivery. No new warranty period is started for these replaced or repaired products.

Liability



WARNING

Use of the equipment in ways other than described in the catalog leaflet and the manual may result in personal injury, death, or property and equipment damage. Use this equipment only as described in the manual.

ADB SAFEGATE cannot be held responsible for injuries or damages resulting from non-standard, unintended uses of its equipment. The equipment is designed and intended only for the purpose described in the manual. Uses not described in the manual are considered unintended uses and may result in serious personal injury, death or property damage.

Unintended uses, includes the following actions:

- Making changes to equipment that have not been recommended or described in this manual or using parts that are not genuine ADB SAFEGATE replacement parts or accessories.
- Failing to make sure that auxiliary equipment complies with approval agency requirements, local codes, and all applicable safety standards if not in contradiction with the general rules.
- Using materials or auxiliary equipment that are inappropriate or incompatible with your ADB SAFEGATE equipment.
- Allowing unskilled personnel to perform any task on or with the equipment.

Copyright Statement

This manual or parts thereof may not be reproduced, stored in a retrieval system, or transmitted, in any form or by any means, electronic, mechanical, photocopying, recording, nor otherwise, without the author's prior written consent.

This manual could contain technical inaccuracies or typographical errors. The author reserves the right to revise this manual from time to time in the contents thereof without obligation of the author to notify any person of such revision or change. Details and values given in this manual are average values and have been compiled with care. They are not binding, however, and the author disclaims any liability for damages or detriments suffered as a result of reliance on the information given herein or the use of products, processes or equipment to which this manual refers. No warranty is made that the use of the information or of the products, processes or equipment to which this manual refers will not infringe any third party's patents or rights. The information given does not release the buyer from making their own experiments and tests.

Table of Contents

1.0 Safety	1
1.1 Safety Messages.....	1
1.1.1 Introduction to Safety.....	2
2.0 Introduction	3
2.1 LED Light Bar Airfield Guidance Sign	3
3.0 Parts	9
3.1 Ordering Code.....	9
3.2 Legend Panel Replacement Ordering Code.....	10
3.3 Ordering Code.....	0
3.4 Ordering Code.....	0
3.5 Legend Panel Replacement.....	0
3.6 Parts Diagrams.....	11
3.7 Spare Parts	12
A.0 SUPPORT	17
A.1 ADB SAFEGATE Website.....	17
A.2 Recycling	18
A.2.1 Local Authority Recycling	18
A.2.2 ADB SAFEGATE Recycling	18

List of Figures

Figure 1: TP312/ICAO LED Sign Assembly Parts	11
Figure 2: ON/OFF Switch Protective Cover	12
Figure 3: Leg Extensions	16

List of Tables

Table 1: ICAO/TP312 LED Sign Spare Parts	13
Table 2: 600 mm Face - Standard Height Sign Coupling	14
Table 3: 600 mm FACE – 48"; 60"; 72" HEIGHT SIGN Coupling.....	14
Table 4: 800 mm Face - Standard Height Sign Couplings	15
Table 5: 800 mm Face - 48"; 60"; 72" Height Sign Couplings.....	15
Table 6: 1200 mm Face - Standard Height Sign Couplings	15
Table 7: Cordset Usage.....	16
Table 8: Cordsets	16

1.0 Safety

Introduction to Safety

This section contains general safety instructions for installing and using ADB SAFEGATE equipment. Some safety instructions may not apply to the equipment in this manual. Task- and equipment-specific warnings are included in other sections of this manual where appropriate.

1.1 Safety Messages

HAZARD Icons used in this manual

For all HAZARD symbols in use, see the Safety section. All symbols must comply with ISO and ANSI standards.

Carefully read and observe all safety instructions in this manual, which alert you to safety hazards and conditions that may result in personal injury, death or property and equipment damage and are accompanied by the symbols shown below.

	<p>WARNING</p> <p>Failure to observe a warning may result in personal injury, death or equipment damage.</p>
	<p>DANGER – Risk of electrical shock or ARC FLASH</p> <p>Disconnect equipment from line voltage. Failure to observe this warning may result in personal injury, death, or equipment damage. ARC Flash may cause blindness, severe burns or death.</p>
	<p>WARNING – Wear personal protective equipment</p> <p>Failure to observe may result in serious injury.</p>
	<p>WARNING – Do not touch</p> <p>Failure to observe this warning may result in personal injury, death, or equipment damage.</p>
	<p>CAUTION</p> <p>Failure to observe a caution may result in equipment damage.</p>
	<p>ELECTROSTATIC SENSITIVE DEVICES</p> <p>This equipment may contain electrostatic devices.</p>

Qualified Personnel

	<p>Important Information</p> <p>The term qualified personnel is defined here as individuals who thoroughly understand the equipment and its safe operation, maintenance and repair. Qualified personnel are physically capable of performing the required tasks, familiar with all relevant safety rules and regulations and have been trained to safely install, operate, maintain and repair the equipment. It is the responsibility of the company operating this equipment to ensure that its personnel meet these requirements.</p> <p>Always use required personal protective equipment (PPE) and follow safe electrical work practice.</p>
--	---

1.1.1 Introduction to Safety



CAUTION

Unsafe Equipment Use

This equipment may contain electrostatic devices, hazardous voltages and sharp edges on components

- Read installation instructions in their entirety before starting installation.
- Become familiar with the general safety instructions in this section of the manual before installing, operating, maintaining or repairing this equipment.
- Read and carefully follow the instructions throughout this manual for performing specific tasks and working with specific equipment.
- Make this manual available to personnel installing, operating, maintaining or repairing this equipment.
- Follow all applicable safety procedures required by your company, industry standards and government or other regulatory agencies.
- Install all electrical connections to local code.
- Use only electrical wire of sufficient gauge and insulation to handle the rated current demand. All wiring must meet local codes.
- Route electrical wiring along a protected path. Make sure they will not be damaged by moving equipment.
- Protect components from damage, wear, and harsh environment conditions.
- Allow ample room for maintenance, panel accessibility, and cover removal.
- Protect equipment with safety devices as specified by applicable safety regulations
- If safety devices must be removed for installation, install them immediately after the work is completed and check them for proper functioning prior to returning power to the circuit.

Failure to follow these instructions can result in serious injury, death or equipment damage

Additional Reference Materials



Important Information

- IEC – International Standards and Conformity Assessment for all electrical, electronic and related technologies.
- IEC 60364 – Electrical Installations in Buildings.
- CSA – C22.2 No.180:13 (R2018), series isolating transformers for airport lighting.
- FAA Advisory: AC 150/5340-26 (current edition), Maintenance of Airport Visual Aid Facilities.
- Maintenance personnel must refer to the maintenance procedure described in the ICAO Airport Services Manual, Part 9.
- ANSI/NFPA 79, Electrical Standards for Metalworking Machine Tools.
- National and local electrical codes and standards.

2.0 Introduction

These signs are designed to guide pilots to a particular point on the field, identify holding positions, identify taxiway and runway intersections, and prohibit aircraft entry into designated areas.



2.1 LED Light Bar Airfield Guidance Sign

Compliance with Standards

ICAO:	Annex 14, Volume I
Canada:	TP 312

Uses

Illuminated airfield guidance signs are used as information, mandatory instruction, position and direction indicators in accordance with ICAO Annex 14, Section 5.4 Signs. The signs are available with 322 km/h wind load compliance.

Information Sign

Informational Direction, Destination, Boundary, and VOR Check-Point signs - black inscription on a yellow background. Designed to guide pilots to a particular point on the airfield by identifying runway exits, taxiway directions, taxiway intersections, taxiway ending, and inbound/outbound destinations, boundaries.

Mandatory signs

Mandatory Instruction sign - white inscription on a red background. Designed to identify holding positions, runway intersections, and prohibit aircraft entry into designated areas.

Location Sign

Runway and Taxiway Location signs - yellow inscription on a black background and only where it is a stand-alone sign shall have a yellow border. Designed to identify taxiway and runway location on which the aircraft is located.

Runway Distance Remaining signs

White inscription on a black background. Designed to provide runway distance remaining information to pilots during takeoff and landing operations. Inscriptions are descending numerals used at 1,000-foot intervals adjacent to the runway edge. Also available as an Illuminated Arrestor Cable Marker (IACM) sign.

Operating Conditions

The taxiway and runway signs are designed for continuous outdoor use under the conditions presented below for operating temperature range, humidity, and wind.

Temperature:	-55 °F to +131 °F (-55 °C to +55 °C)
Humidity:	0 to 100%
Wind:	ADB SAFEGATE standard signs withstand a wind loading of 322 km/h (200 mph) and break before the wind loading reaches 480 km/h (300 mph).

Features

- Unique LED light bar design maximizes energy efficiency

- Available battery-powered tester provides for quick and easy testing of individual LED light bars
- Electrical design uses a minimal number of components which maximizes sign MTBF and greatly simplifies troubleshooting efforts
- Virtually eliminates runway and taxiway shutdowns due to long-lasting LED light source
- Creates a highly uniform distribution of light, eliminating hot spots and shadows
- Operates on ferroresonant or thyristor CCRs that are designed in compliance with FAA or IEC requirements
- Operates on all steps of a 3-step or 5-step CCR and on a 1-step CCR
- Exceeds latest ICAO and TP 312 requirements for Chromaticity
- Maintains constant luminosity at maximum brightness on all CCR steps
- Improved safety with regulated low DC voltage inside sign
- Eliminates re-lamp expenses and reduces on-going maintenance cost
- Modular construction: commonality of mechanical and electrical components throughout entire sign range
- Low mass, frangible, rigid construction of aluminum frame extrusions
- Protection class: IP 54

Electrical Supply

Signs are internally lighted. The signs are connected to a series circuit using the appropriately-sized 50 or 60 Hz isolation transformer.

Construction

Corrosion-resistant sign construction requires minimal maintenance. The sign uses aluminum housing, stainless steel hardware, and translucent acrylic legend panels.

Sign Dimensions - Standard Mounting Height Shown - inch(mm)

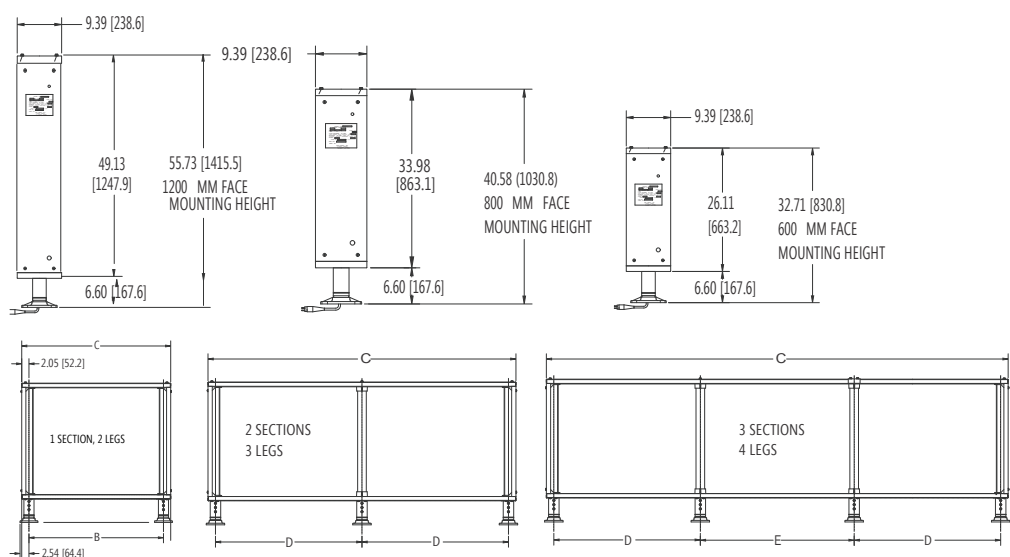

Sign Type	Illuminated Face Length	B	C	D	E
1 Section, 2 Legs					
SBXA	700 mm	655.3 (25.90)	759.7 (29.92)	NA	NA
SBXB	900 mm	855.5 (33.68)	959.9 (37.79)	NA	NA
SBXC	1100 mm	1055.4 (41.55)	1159.8 (45.66)	NA	NA
SBXD	1300 mm	1255.3 (49.42)	1359.7 (53.53)	NA	NA
SBXE	1500 mm	1455.4 (57.30)	1559.8 (61.41)	NA	NA
2 Section, 3 Legs					
SBXF	1700 mm	NA	1759.7 (69.28)	827.7 (32.59)	NA
SBXG	1900 mm	NA	1959.7 (77.16)	927.7 (36.53)	NA
SBXH	2100 mm	NA	2159.7 (85.03)	1027.7 (40.26)	NA
SBXJ	2300 mm	NA	2359.7 (92.90)	1127.7 (44.40)	NA
SBXK	2500 mm	NA	2559.7 (100.78)	1227.7 (48.34)	NA
SBXL	2700 mm	NA	2759.7 (108.65)	1327.7 (52.27)	NA
SBXM	2900 mm	NA	2959.7 (116.53)	1427.7 (56.21)	NA
SBKQ	1200 mm	NA	1215.1 (47.84)	555.5 (21.87)	NA
3 Section, 4 Legs					
SBXN	3300 mm	NA	3359.7 (132.27)	1077.7 (42.43)	1100.0 (43.31)
SBXP	3700 mm	NA	3636.5 (143.17)	1277.7 (50.30)	1100.0 (43.31)

Electrical Supply

Signs are internally lighted and are connected to a series circuit using the appropriately-sized 50 or 60 Hz L-830/L-831 isolation transformer.

Sign Load & Transformer Requirements

Sign Type	Sign Length	1-Step (5.5A)			3-Step (4.8-6.6A)			5-Step (2.8-6.6A)		
		Transformer	Power Factor	VA	Transformer	Power Factor	VA	Transformer	Power Factor	VA
SBXA	700	200 W	0.89	124	300 W	0.87	150	300 W	0.85	151
SBXB	900	300 W	0.87	135	300 W	0.86	168	300 W	0.84	168
SBXC	1100	300 W	0.82	103	300 W	0.87	118	300 W	0.83	119
SBXD	1300	300 W	0.88	121	300 W	0.88	132	300 W	0.84	134
SBXE	1500	300 W	0.87	135	300 W	0.84	150	300 W	0.84	148
SBXF	1700	300 W	0.87	135	300 W	0.84	150	300 W	0.84	148
SBXG	1900	300 W	0.87	135	300 W	0.84	150	300 W	0.84	148
SBXH	2100	300 W	0.88	168	300 W	0.87	180	500 W	0.84	184
SBXJ	2300	300 W	0.88	168	300 W	0.87	180	500 W	0.84	184
SBXK	2500	300 W	0.89	220	500 W	0.88	241	(2)300 W	0.84	261
SBXL	2700	300 W	0.89	220	500 W	0.88	241	(2)300 W	0.84	261
SBXM	2900	500 W	0.89	255	(2)300 W	0.88	295	(2)300 W	0.84	291
SBXN	3300	500 W	0.89	255	(2)300 W	0.88	295	(2)300 W	0.84	291
SBXP	3700	500 W	0.89	252	(2)300 W	0.88	289	(2)500 W	0.84	299
SBKQ	1200	300 W	0.91	162	300 W	0.90	174	500 W	0.91	174



Note

- In the table above, the number for the total VA load imposed on the CCR represents the actual load imposed on the regulator and accounts for power factor and load imposed by the transformer. For signs that require two transformers a wye connector 94A0173 (ordered separately) is required to connect the transformers in series. Load data are estimates for worst case scenario.

Packaging Data (600 mm Signs)

Signs are shipped with L-823 cord set(s), frangible couplings, and mounting flanges - ready for installation.

Sign Type	Gross Assembled Weight								Carton Dimensions (h × w × d)	
	SB6X Standard Height		SBDX 1219 mm (48")		SBEX ¹ 1524 mm (60")		SBFX ¹ 1829 mm (72")			
	(lb)	(kg)	(lb)	(kg)	(lb)	(kg)	(lb)	(kg)	(in)	(mm)
SBXA	64	29.0	69	31.3	75	34.0	79	35.8	36 × 37 × 13	914 × 950 × 330
SBXB	72	32.6	77	34.9	83	37.6	87	39.5	36 × 45 × 13	914 × 1150 × 330
SBXC	80	36.3	85	38.5	91	41.3	95	43.1	36 × 53 × 13	914 × 1350 × 330
SBXD	88	39.9	93	42.2	99	44.9	103	46.7	36 × 61 × 13	914 × 1550 × 330
SBXE	97	44.0	102	46.3	108	49.0	112	50.8	36 × 70 × 13	914 × 1750 × 330
SBXF	122	55.3	130	59.0	138	62.6	145	65.8	36 × 77 × 13	914 × 1950 × 330
SBXG	130	59.0	138	62.6	146	66.2	153	69.4	36 × 85 × 13	914 × 2150 × 330
SBXH	138	62.6	146	66.2	154	69.8	161	73.0	36 × 93 × 13	914 × 2350 × 330
SBXJ	146	66.2	154	68.9	162	73.5	169	76.6	36 × 100 × 13	914 × 2550 × 330
SBXK	153	69.4	161	73.0	169	76.6	176	79.8	36 × 108 × 13	914 × 2750 × 330
SBXL	161	73.0	169	76.6	177	80.3	184	83.5	36 × 116 × 13	914 × 2950 × 330
SBXM	169	76.6	177	80.3	185	83.9	192	87.1	36 × 124 × 13	914 × 3150 × 330
SBXN	203	92.1	213	96.6	225	102.0	233	101.1	36 × 140 × 13	914 × 3550 × 330
SBXP	220	99.8	230	104.3	242	109.8	250	113.4	36 × 156 × 13	914 × 3950 × 330



Note

- 1219 mm (48 in) signs ship as 1295 mm (51 in) height.
- 1524 mm (60 in) and 1829 mm (72 in) signs ship as standard height.

¹Shipped same carton size as standard height; legs enclosed separately; requires assembly.

Packaging Data (800 mm Signs)

Signs are shipped with L-823 cord set(s), frangible couplings, and mounting flanges - ready for installation.

Sign Type	Gross Assembled Weight								Carton Dimensions (h × w × d)	
	SB8X Standard Height		SBGX 1219 mm (48")		SBHX ¹ 1524 mm (60")		SBJX ¹ 1829 mm (72")		(in)	(mm)
	(lb)	(kg)	(lb)	(kg)	(lb)	(kg)	(lb)	(kg)		
SBXA	72	32.6	77	34.9	83	37.6	87	39.5	43.5 X 37 X 13	1105 X 960 X 330
SBXB	82	37.0	87	39.5	93	42.2	97	44.0	43.5 X 45 X 13	1105 X 1150 X 330
SBXC	94	42.6	99	44.9	105	47.6	109	49.4	43.5 X 53 X 13	1105 X 1350 X 330
SBXD	104	47.0	109	49.4	115	52.2	119	54	43.5 X 61 X 13	1105 X 1550 X 330
SBXE	114	51.7	119	54.0	125	56.7	129	58.5	43.5 X 70 X 13	1105 X 1750 X 330
SBXF	136	61.7	144	65.3	152	68.9	159	72.1	43.5 X 77 X 13	1105 X 1950 X 330
SBXG	149	67.6	157	71.2	165	74.8	172	78.0	43.5 X 85 X 13	1105 X 2150 X 330
SBXH	161	73.0	169	76.7	177	80.3	184	83.5	43.5 X 93 X 13	1105 X 2350 X 330
SBXJ	173	78.5	181	82.1	189	85.7	196	88.9	43.5 X 100 X 13	1105 X 2550 X 330
SBXK	182	82.5	190	86.2	198	89.8	205	93.0	43.5 X 108 X 13	1105 X 2750 X 330
SBXL	193	87.5	201	91.2	209	94.8	216	98.0	43.5 X 116 X 13	1105 X 2950 X 330
SBXM	205	93.0	213	96.6	221	100.2	228	103.4	43.5 X 124 X 13	1105 X 3150 X 330
SBXN	242	110.0	252	114.3	264	119.7	272	123.4	43.5 X 140 X 13	1105 X 3550 X 330
SBXP	265	120.2	275	124.7	287	130.2	294	133.4	43.5 X 156 X 13	1105 X 3950 X 330



Note

- 1219 mm (48 in) signs ship as 1295 mm (51 in) height.
- 1524 mm (60 in) and 1829 mm (72 in) signs ship as standard height.

Packaging Data (1200 mm Signs)

Signs are shipped with L-823 cord set(s), frangible couplings, and mounting flanges - ready for installation.

Sign Type	Gross Assembled Weight			
	Standard Height		Carton Dimensions (h × w × d)	
	(lb)	(kg)	(in)	(mm)
SBKQ	122	56.0	62x52x13	158x132x33



Note

Left/right designation determined when viewing secondary side of the sign. Customer to provide legend information and power connection side. Match power cord exit location with legend side. All signs are provided with an internal inspection window at the end of the sign.

3.2 Legend Panel Replacement Ordering Code

Legend Panel Replacement

Visible Face Height
Visible Panel Width
Panel Type
Wind Rating

44A7433/ 0

Panel Type

- 1 = With legend
- 2 = Black (blank)

Wind Rating

- 0 = Standard (322 km/h, 200 mph)

Visible Face Height

- 6 = 600 mm
- 8 = 800 mm

Visible Panel Width

- 07 = 700 mm
- 09 = 900 mm
- 11 = 1100 mm
- 13 = 1300 mm
- 15 = 1500 mm
- 17 = 1700 mm
- 19 = 1900 mm
- 21 = 2100 mm
- 23 = 2300 mm
- 25 = 2500 mm
- 27 = 2700 mm
- 29 = 2900 mm
- 33 = 3300 mm
- 37 = 3700 mm



Note

Customer to specify character height and legend information.

LED Light Engine Tester (Ordering Code: 44A76264/1)

Battery-powered tester is used during maintenance activities to separately test a single LED light bar. Uses four size D batteries and outputs 350 mA. Output is activated using a momentary switch.

3.3 Parts Diagrams

Figure 1: TP312/ICAO LED Sign Assembly Parts

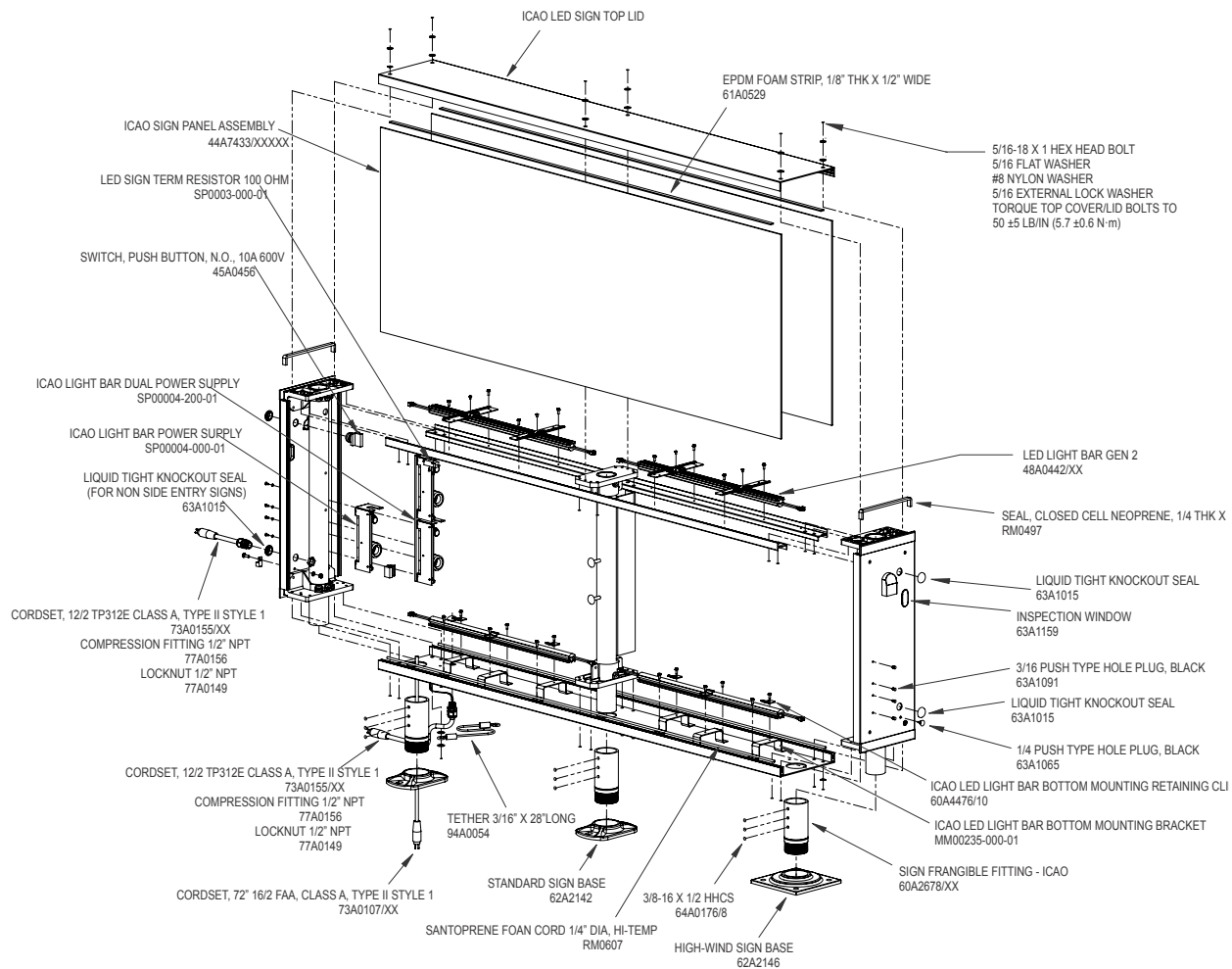

Note

TORQUE ALL:

5/16-18 bolts to 115 ± 10 inch-pounds, (13 ± 1 N·m) (except: top cover lid bolts)

Torque 5/16-18 top cover lid bolts to 50 ±5 lb/in (5.7 ±0.6 N·m).

3/8-16 bolts to 200 ± 10 inch-pounds (22.6 ± 1 N·m)

Order kit 94A0649/ICAONB for a factory installed cover for the ON/OFF switch. The cover protects from inadvertent operation of the button associated with heavy snow being piled or blown against the sign.

Figure 2: ON/OFF Switch Protective Cover

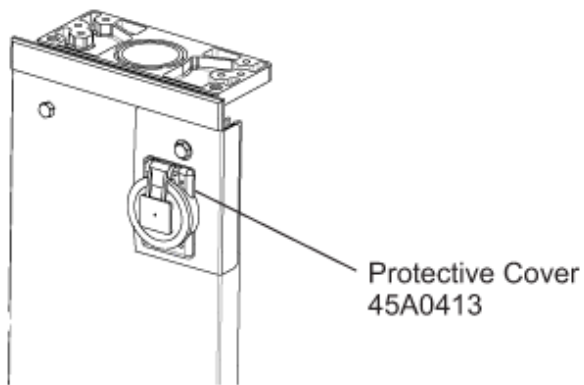

3.4 Spare Parts

Create a sufficiently large stock of spare parts to maintain the ICAO/TP312 LED Signs in the field. Consider acquiring approximately 10% of critical spare final assemblies (with a minimum quantity of one) for the total amount of equipment in the field. This allows for repairs to be made in the shop.

For the ICAO/TP312 LED Sign, see the tables below for spares.

- Consider acquiring 10% spares for critical components noted as (A) in the table below.
If only a small number of LED SIGN units are installed, consider acquiring at least one of each of the components noted as (A) below.
- For large installations also consider acquiring 1% spares for parts noted as (B) in the table below. If it is important to have a robust level of spare parts on-hand, and only a small number of LED Signs are installed, consider acquiring one of each of the components noted as (B) below.

Table 1: ICAO/TP312 LED Sign Spare Parts

Part Number	Description	Figure	Notes	Spares
73A0107/XX	Cord set, L-823 (power through leg)	Figure 1	If Used	B
73A0155/X.X	Cord set, TP 312E, 12/2 SO cord, 2.5 m (other sign exit locations)	Figure 1	If Used	B
62A2142	Floor flange (2-bolt) ¹	Figure 1		B
62A2146	Floor flange (4-bolt) ¹	Figure 1		B
48A0442/16	LED Light Bar, 16"	Figure 1		A
48A0442/24	LED Light Bar, 24"	Figure 1		A
48A0442/32	LED Light Bar, 32"	Figure 1		A
94A0054	Tether	Figure 1		B
60A2678/XX	Sign Frangible Coupling - ICAO 600 mm Sign, Standard ¹²³	Figure 9 and Figure 1	see Table 2 and Table 3	B
60AXXX/XX	Sign Frangible Coupling - ICAO 800 mm Sign, Standard ¹²³	Figure 9	see Table 4 and Table 5	B
SP00004-200-01	Dual Power Supply Assembly ⁴⁵	Figure 1		A
SP00004-000-01	Single Power Supply Assembly ⁶⁵	Figure 1		A
SP00003-000-01	LED Sign Terminal Assembly Resistor 100 Ohm			B
45A0456	Switch Push Button, NO, 10 A, 600 VAC		If Used	B
RM0607	Foam Cord 1/4" Dia HI-Temp ⁷	Figure 1	Used in bottom sign panel channel; ordered by foot	B
61A0529	EPDM Foam Strip, 1/8 in Thick x 1/2 in Wide (top faces above sign panel) ⁸	Figure 1	ordered by foot	B
60A4323/XXX	Leg Extension	Figure 3		B
44A7264/1	Light Bar Tester			B
MM00235-000-01	Bottom LED Standoff Mounting Bracket		1200x1200 mm RDRS sign only	B
MM00099-000-01	Side LED Mounting U-Bolt		1200x1200 mm RDRS sign only	B
MM00255-000-01	Side LED Mounting Plate		1200x1200 mm RDRS sign only	B

¹ Refer to Tables 13 through 16 for the right floor flange.

² Refer to drawing 117A0069, ICAO & TP312 installation detail, for frangible coupling and foot option specification.

³ Apply 67A0105 LOCTITE anti-seize to all frangible coupling threads.

⁴ SP00004-200-01 dual power supply assembly used on illuminated face length options "L" through "P".

⁵ See Figures 18 and 19 for configuration instruction.

⁶ SP00004-000-01 single power supply used on illuminated face length options "A" through "K".

⁷ RM0607 gaskets are cut to length and placed inside the channels along each side of the bottom panels.

⁸ 61A0529 gaskets are cut to length and affixed with the adhesive side along both inside corners of the sign top lid.



Note

Installation drawing 117A0069 is available on the ADB SAFEGATE's website or you can request a copy from your sales representative

Table 2: 600 mm Face - Standard Height Sign Coupling

Size Modules	Illuminated Face Length	Frangible Coupling	Mounting Flange
SBXA/, SIXA/	700 mm	60A2678/10	62A2142
SBXB/, SIXB/	900 mm	60A2678/10	62A2142
SBXC/, SIXC/	1100 mm	60A2678/60	62A2142
SBXD/, SIXD/	1300 mm	60A2678/60	62A2142
SBXE/, SIXE/	1500 mm	60A2678/20	62A2142
SBXF/, SIXF/	1700 mm	60A2678/60	62A2142
SBXG/, SIXG/	1900 mm	60A2678/20	62A2142
SBXH/, SIXH/	2100 mm	60A2678/20	62A2142
SBXJ/, SIXJ/	2300 mm	60A2678/30	62A2142
SBXK/, SIXK/	2500 mm	60A2678/30	62A2142
SBXL/, SIXL/	2700 mm	60A2678/30	62A2142
SBXM/, SIXM/	2900 mm	60A2678/30	62A2142
SBXN/, SIXN/	3300 mm	60A2678/30	62A2142
SBXP/, SIXP/	3700 mm	60A2678/40	62A2142

Table 3: 600 mm FACE - 48"; 60"; 72" HEIGHT SIGN Coupling

Size Modules	Illuminated Face Length	Frangible Coupling	Mounting Flange
SBXA/, SIXA/	700 mm	60A2678/60	62A2142
SBXB/, SIXB/	900 mm	60A2678/20	62A2142
SBXC/, SIXC/	1100 mm	60A2678/30	62A2142
SBXD/, SIXD/	1300 mm	60A2678/40	62A2142
SBXE/, SIXE/	1500 mm	60A2678/40	62A2142
SBXF/, SIXF/	1700 mm	60A2678/40	62A2142
SBXG/, SIXG/	1900 mm	60A2678/21	62A2146
SBXH/, SIXH/	2100 mm	60A2678/21	62A2146
SBXJ/, SIXJ/	2300 mm	60A2678/50	62A2146
SBXK/, SIXK/	2500 mm	60A2678/50	62A2146
SBXL/, SIXL/	2700 mm	60A2678/41	62A2146
SBXM/, SIXM/	2900 mm	60A2678/41	62A2146
SBXN/, SIXN/	3300 mm	60A2678/41	62A2146
SBXP/, SIXP/	3700 mm	60A2678/41	62A2146

Table 4: 800 mm Face - Standard Height Sign Couplings

Size Modules	Illuminated Face Length	Frangible Coupling	Mounting Flange
SBXA/, SIXA/	700 mm	60A2678/60	62A2142
SBXB/, SIXB/	900 mm	60A2678/20	62A2142
SBXC/, SIXC/	1100 mm	60A2678/20	62A2142
SBXD/, SIXD/	1300 mm	60A2678/30	62A2142
SBXE/, SIXE/	1500 mm	60A2678/40	62A2142
SBXF/, SIXF/	1700 mm	60A2678/30	62A2142
SBXG/, SIXG/	1900 mm	60A2678/40	62A2142
SBXH/, SIXH/	2100 mm	60A2678/21	62A2146
SBXJ/, SIXJ/	2300 mm	60A2678/21	62A2146
SBXK/, SIXK/	2500 mm	60A2678/50	62A2146
SBXL/, SIXL/	2700 mm	60A2678/50	62A2146
SBXM/, SIXM/	2900 mm	60A2678/50	62A2146
SBXN/, SIXN/	3300 mm	60A2678/50	62A2146
SBXP/, SIXP/	3700 mm	60A2678/50	62A2146

Table 5: 800 mm Face - 48"; 60"; 72" Height Sign Couplings

Size Modules	Illuminated Face Length	Frangible Coupling	Mounting Flange
SBXA/, SIXA/	700 mm	60A2678/20	62A2142
SBXB/, SIXB/	900 mm	60A2678/30	62A2142
SBXC/, SIXC/	1100 mm	60A2678/30	62A2142
SBXD/, SIXD/	1300 mm	60A2678/40	62A2142
SBXE/, SIXE/	1500 mm	60A2678/21	62A2146
SBXF/, SIXF/	1700 mm	60A2678/21	62A2146
SBXG/, SIXG/	1900 mm	60A2678/50	62A2146
SBXH/, SIXH/	2100 mm	60A2678/50	62A2146
SBXJ/, SIXJ/	2300 mm	60A2678/41	62A2146
SBXK/, SIXK/	2500 mm	60A2678/41	62A2146
SBXL/, SIXL/	2700 mm	60A2678/41	62A2146
SBXM/, SIXM/	2900 mm	60A2678/41	62A2146
SBXN/, SIXN/	3300 mm	60A2678/41	62A2146
SBXP/, SIXP/	3700 mm	60A2678/41	62A2146

Table 6: 1200 mm Face - Standard Height Sign Couplings

Size	Length	Frangible Coupling	Mounting Flange
SBKQ	1200 mm	60A2678/40	62A2142

Figure 3: Leg Extensions

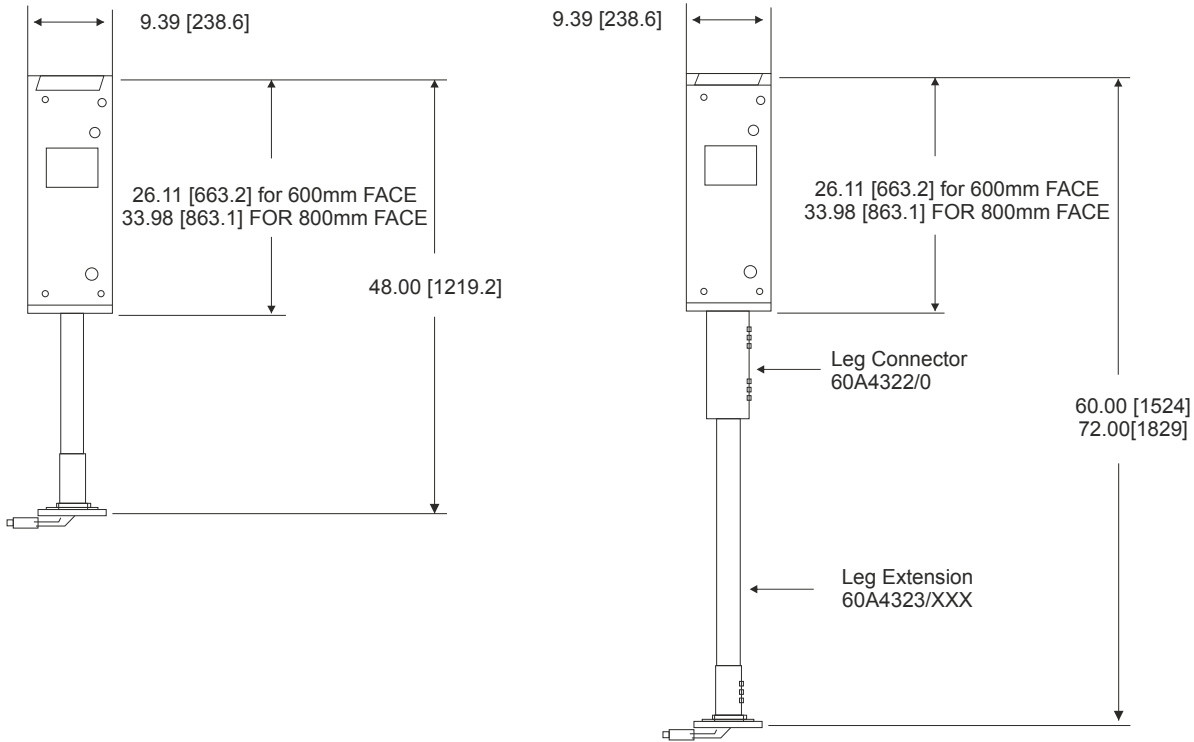

Table 7: Cordset Usage

DIGIT 3 - HEIGHT		DIGIT 9 - POWER	
6, 8, D, E, F, G, H, J	Sign Height	1, 2 THRU LEG	3, 4, 5, 6, 7, 8 SIDE, BOTTOM, CUSTOMER PROVIDED
SB6X	600 mm Standard	73A0107/72	73A0155/1.5
SB8X	800 mm Standard	73A0107/72	73A0155/1.5
SBDX	600 mm 48" (1219 mm) OAH	73A0107/72	73A0155/1.5
SBEX	600 mm 60" (1524 mm) OAH	73A0107/98	73A0155/2.5
SBFX	600 mm 72" (1829 mm) OAH	73A0107/98	73A0155/2.5
SBGX	800 mm 48" (1219 mm) OAH	73A0107/98	73A0155/2.5
SBHX	800 mm 60" (1524 mm) OAH	73A0107/98	73A0155/2.5
SBJX	800 mm 72" (1829 mm) OAH	73A0107/98	73A0155/2.5
SBKQ	1200 Standard	73A0107/72	73A0155/1.5

Table 8: Cordsets

CORD	DESCRIPTION	CONDUCTORS	JACKET DIA.
73A0107/72	L-823 C.SET FAA CLASS A TY II ST1, 72"L	16/2	0.38 in
73A0107/98	CORDSET 98" 16/2 SOW 600V ST 1 STRIPPED	16/2	0.38 in
73A0155/1.5	CORDSET 1.5 M (59") 12/2 SOW 600V ST 1	12/2	0.50 in
73A0155/2.5	CORDSET 2.5 M (98") 12/2 SOW 600V ST 1	12/2	0.50 in

Appendix A: SUPPORT

Our experienced engineers are available for support and service at all times, 24 hour/7 days a week. They are part of a dynamic organization making sure the entire ADB SAFEGATE is committed to minimal disturbance for airport operations.

ADB SAFEGATE Support

Technical Support – Global

Customers in Europe, the Middle East, Africa or Asia Pacific are more than welcome to our portal for technical support. Trained in all areas of system issues, troubleshooting, quality control and technical assistance, our highly experienced Technical support specialists are available 24 hours a day, seven days a week to provide assistance over the phone. In the Americas, we also offer live technical support.

Live Technical Support – Americas

If at any time you have a question or concern about your product, contact ADB SAFEGATE's US-based technical support specialists, available 24 hours a day, seven days a week, to assist you via phone.

ADB SAFEGATE Americas Technical Service & Support (US & Canada) :+1-800-545-4157

ADB SAFEGATE Americas Technical Service & Support (Canada): +1-905-631-1597

ADB SAFEGATE Americas Technical Service & Support (International): +1-614-861-1304

We can also be reached via email during regular business hours:

Airfield and Gate: techservice.us@adbsafegate.com

Gate: gateservice.us@adbsafegate.com

We look forward to working with you!

Before You Call

When you have an airfield lighting or system control system problem, prior to calling, please ensure the following:

- Review the product's manual and troubleshooting guide.
- Be located with the product ready to troubleshoot.
- Have all necessary information available: airport code/company name, customer id number, contact phone number/email address, product/part number.
- Have a True RMS meter available and any other necessary tools.

When calling about an issue with Safedock A-VDGS, we can serve you better if you collect the following information before you call:

- Relevant information regarding the issue you are calling about, such as gate number, flight number, aircraft type and time of the event.
- What, if any, actions have been taken to resolve the issue prior to the call.
- If available, provide a CCTV recording of the incident to aid in aligning the information from the Safedock log file.



Note

For more information, see www.adbsafegate.com, contact ADB SAFEGATE Support via email at support@adbsafegate.com or Europe: +32 2 722 17 11

Americas: +1 614 861 1304. Press 3 for technical service or press 4 for sales support.

China: +86 (10) 8476 0106

Middle East and Africa: +971 4 452 7575

A.1 ADB SAFEGATE Website

The ADB SAFEGATE website, www.adbsafegate.com, offers information regarding our airport solutions, products, company, news, links, downloads, references, contacts and more.

A.2 Recycling

A.2.1 Local Authority Recycling

The disposal of ADB SAFEGATE products is to be made at an applicable collection point for the recycling of electrical and electronic equipment. The correct disposal of equipment prevents any potential negative consequences for the environment and human health, which could otherwise be caused by inappropriate waste handling. The recycling of materials helps to conserve natural resources. For more detailed information about recycling of products, contact your local authority city office.

A.2.2 ADB SAFEGATE Recycling

ADB SAFEGATE is fully committed to environmentally-conscious manufacturing with strict monitoring of our own processes as well as supplier components and sub-contractor operations. ADB SAFEGATE offers a recycling program for our products to all customers worldwide, whether or not the products were sold within the EU.

ADB SAFEGATE products and/or specific electrical and electronic component parts which are fully removed/separated from any customer equipment and returned will be accepted for our recycling program.

All items returned must be clearly labeled as follows:

- For RoHS/WEEE Recycling
- Sender contact information (Name, Business Address, Phone number).
- Main Unit Serial Number.

ADB SAFEGATE will continue to monitor and update according for any future requirements for EU directives as and when EU member states implement new regulations and or amendments. It is our aim to maintain our compliance plan and assist our customers.

Company Addresses

ADB SAFEGATE, Belgium	ADB SAFEGATE BV Leuvensesteenweg 585 B-1930 Zaventem Belgium
Contact:	
Tel.: +32 2 722 17 11	Email: marketing@adbsafegate.com
Fax: +32 2 722 17 64	Internet: www.adbsafegate.com
ADB SAFEGATE, Americas	ADB SAFEGATE Americas, LLC 700 Science Blvd Gahanna, OH 43230 USA
Contact:	
Tel.: +1 (614) 861 1304	Email: sales.us@adbsafegate.com
Fax: +1 (614) 864 2069	Internet: www.adbsafegate.com
ADB SAFEGATE, Sweden	ADB SAFEGATE Sweden AB Djurhagegatan 19 SE-213 76 Malmö Sweden
Contact:	
Tel.: +46 (0)40 699 17 00	Email: marketing@adbsafegate.com
Fax: +46 (0)40 699 17 30	Internet: www.adbsafegate.com
ADB SAFEGATE, China	ADB SAFEGATE Airfield Technologies Ltd. China Unit 603, D Block, CAMIC International Convention Center, No 3, Hua Jia Di East road, ChaoYang district, Beijing 100102 P.R. China
Contact:	
Tel.: +86 (10) 8476 0106	Email: china@safegate.com
Fax: +86 (10) 8476 0090	Internet: www.adbsafegate.com
ADB SAFEGATE, Germany	ADB SAFEGATE Germany GmbH Konrad-Zuse-Ring 6, D-68163 Mannheim Germany
Contact:	
Tel.: +49 (621) 87 55 76-0	Email: marketing@adbsafegate.com
Fax: +49 (621) 87 55 76-55	Internet: www.adbsafegate.com

WWW.ADBSAFEGATE.COM

Empowering the Airside Evolution

SMARTER. BETTER. NOW.

