

INSTALLATION & MOUNTING

Light Bases

L-867/L-868



Compliance with Standards

FAA: L-867 & L-868 AC 150/5345-42 (Current Edition)

Uses

FAA L-867

Applications subject to occasional light vehicular loads but no aircraft or other heavy vehicular loads. Some product applications are:

- Elevated Lights
- Navaids such as Precision Approach Path Indicators (PAPI), Runway End Identifier Lights (REIL), and ALSF/MALSR Approach Systems
- Signs
- Junction/Splice Box

FAA L-868

Applications subject to aircraft and other heavy vehicular loads. Some product applications are:

- Runway In-pavement Lights
- Taxiway In-pavement Lights
- Junction/Splice Box

Features

- One- and two-piece configurations
- Extensions and spacers available
- Manufactured in the USA by ETL-Certified suppliers
- Supplied with 2-2" grommeted or threaded hub openings at 0-180° (standard). Optional locations and sizes available.
- All bases provided with an internal and external ground strap
- One copper ground lug kit provided with each base (standard). A second ground lug kit can be provided as an option.
- Optional drain hole or hub in user-specified sizes
- Standard bases provided as Class IA, galvanized steel unless otherwise specified
- Optional Class IB available in stainless steel or internal epoxy coating. See ordering code for options.

Optional Replaceable Threaded Inserts

Optional RTI (replaceable threaded insert) system facilitates:

- Replacement of failed threaded fixture-mounting bolt holes
- Replacement of stripped, sheared, cross-threaded, frozen fixture-mounting bolts
- Does not require changing the azimuth location of the base bolt circle
- Accommodates standard, non proprietary spacer rings and flange rings (with/without dam rings)
- Kit part numbers to add RTI to L-867/L-868 bases:
 - L-867 Base – L867RTI06 (set of six inserts)
 - L-868 Base – L868RTI12 (set of twelve inserts)

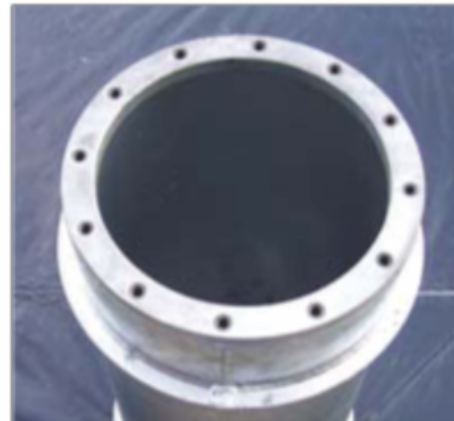

L-868 Replacement Insert

INSTALLATION & MOUNTING

Light Bases

Ordering Code

FAA Type & Size

- 867B = 12" diameter
- 867BT = Telescoping, 12" diameter
- 867D = 16" diameter
- 867DT = Telescoping, 16" diameter
- 867DD = 16" diameter with 0.5" dam
- 867E = 24" diameter
- 868A = 8" diameter
- 868AB = Bottom section, 8" diameter
- 868B = 12" diameter
- 868BB = Bottom section, 12" diameter
- 868C = 15" diameter
- 868CB = Bottom section, 15" diameter

Height

- 20 = 20 inches overall height
- 24 = 24 inches overall height
- XX = Customer specified in inches

Type of Opening

- B = Mixed type and/or size¹
- C = 2-inch Coupling
- F = 2-inch Flex (Grommet)
- G = 3-inch Flex
- H = 3-inch Coupling
- S = 0.75-inch Coupling
- T = 0.75-inch Flex

Opening Quantity and Location

- 1 = One opening at 0°³
- 2 = Two openings at 0°, 180°
- 3 = Three openings at 0°, 90°, 180°
- 4 = Four openings at 0°, 90°, 180°, 270°
- 5 = Five openings at 0°, 0°, 90°, 180°, 180°
- 6 = Six openings - customer specified
- 7 = Four openings at 0°, 0°, 180°, 180° (stacked)
- 9 = Two openings at 0°, 90°³
- A = Three 2" flex at 0°, 90°, 180°, one 2" coupling at 270°²
- B = One 2" flex at 0°; one 3" flex at 180°²
- C = One 2" coupling at 0°; one 3" coupling at 180°²
- N = Non-standard; to be defined by customer

XXXXXX XX X X X X XX

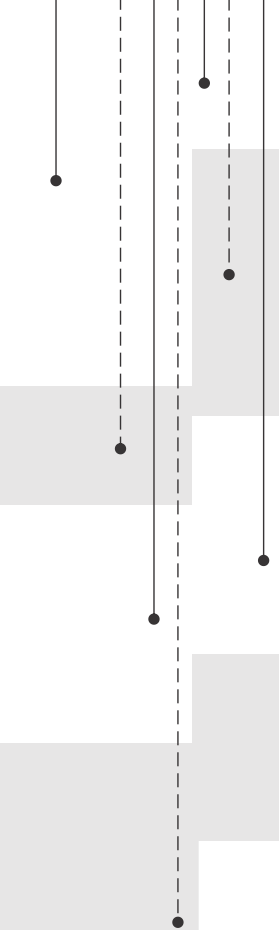

Drain Type

- C = Coupling
- F = Flex (Grommet)
- H = Hole
- N = None

Drain Size

- 0 = None
- 1 = 1 inch
- 2 = 2 inch
- 3 = 0.75 inch
- 4 = 0.5 inch
- 5 = 0.5-inch offset, 3.5 inches from center
- 6 = 0.75-inch offset, 3.5 inches from center
- 7 = 1-inch offset, 3.5 inches from center

Class IB or RWSL Options

- SS = Stainless steel
- 01 = With 48" 1/0 bare copper earth ground wire
- Z0 = RWSL copper clamp (PN AGNDSSASSY0_3125) w/out earth ground wire
- Z1 = RWSL copper clamp with externally attached 48" 1/0 bare copper earth ground wire
- NY = 0.25" thick bottom plate and/or 0.13" thick wall

Notes

- ¹ Only use with options A, B or C under Opening Quantity and Location
- ² Only use with option B under Type of Opening
- ³ Base must have opening at 0° and 180° to allow for draining of the galvanizing materials. A solid grommet will be installed at 180°.

Base Options

Description	Part No.
(4) side-mounted, anti-rotation fins in 90° pattern. Typically used with L-868 load bearing bases.	ANTI-FIN
(6) bottom-mounted, anti-rotation hooks/bars in 60° pattern. Typically used with shallow L-868 load bearing bases.	ANTI-HOOK
Copper Ground Lug Kit. (Each base supplied w/one).	0919

Light Bases

L-867 Light Base

- Tapped holes in top flange rings are located on centerline of couplings. Tolerance: ± 0.1875 inch (0.47 cm).
- Light bases available with either 2-inch (5.08 cm) NPT hub or 2-inch (5.08 cm) grommet openings. Couplings located 180° apart. Tolerance: $\pm 1^\circ$.
- Threads inside couplings are protected with L.D.P.E. plugs
- All light bases provided with an Exterior Grade CC plywood shipping cover that is 0.5-inch (1.27 cm) thick grade CC with 0.4375-inch (1.11 cm) diameter bolt holes
- Six 3/8-inch-16 \times 1-inch stainless steel machine screws secure the plywood shipping cover to the light base
- Optional second ground lug kit for grounding provision and/or drain coupling or weep hole must be specified when ordering
- Finish is hot dip galvanized per ASTM A123/A123M-02 and A153 or material is 304 stainless steel
- Standard lengths for the 12-inch (30.48 cm) diameter light base are 20 inches (50.8 cm) and 24 inches (60.96 cm) with a tolerance of ± 0.25 inch. Standard lengths for the 16-inch (40.64 cm) diameter light base are 20 inches (50.80 cm) and 24 inches (60.96 cm) with a tolerance of ± 0.25 inch. Standard lengths for the 24-inch (60.96 cm) diameter light base are 20 inches (50.80 cm) and 24 inches (60.96 cm) with a tolerance of ± 0.25 inch. Custom heights available.
- Adjustable L-867 telescoping bases available. Please contact the ADB Safegate Sales Department for details.

Dimensions - L-867

Inches					
Nom. Dia.	"A"	"B"	"C"	"D"	
12.0	13.500	10.250	12.250	9.250	
16.0	17.375	14.250	16.250	12.375	
24.0	24.000	21.500	22.500	20.000	
Centimeters					
Nom. Dia.	"A"	"B"	"C"	"D"	
30.5	34.290	26.035	31.115	23.495	
40.6	44.133	36.195	41.275	31.433	
61.0	60.960	54.610	57.150	50.800	

L-868 Light Base

- Light bases available with either 2-inch (5.08 cm) NPT hub or 2-inch (5.08 cm) grommeted openings. Couplings or grommeted openings located 180° apart. Tolerance: $\pm 1^\circ$
- Threads inside hubs are protected with L.D.P.E. plugs
- All light bases are provided with a nylon (standard) or plywood (optional) shipping cover:
 - 8-in (20.3 cm) Nom. O.D.: 8.5-in dia. \times 0.750-in thick (21.590 cm \times 1.905 cm)
 - 12-in (30.5 cm) Nom. O.D.: 12.5-in dia. \times 0.750-in thick (31.75 cm \times 1.905 cm)
 - 15-in (38.1 cm) Nom. O.D.: 17.750-in dia. \times 1.25-in thick (45.085 cm \times 3.175 cm)
- Six 3/8-inch -16 \times 1-inch stainless steel machine screws secure the plywood shipping cover to the light base
- Finish is hot dip galvanized per ASTM A123/A123M-02 and A153 or material is 304 stainless steel
- Optional Equipment – Second ground lug kit for grounding provision, drain coupling or opening. Anti-rotation bars must be specified when ordering.

Dimensions - L-868

Inches					
Nom. Dia.	"A"	"B"	"C"	"E"	"F"
8.0	8.5000	7.250	6.500	9.000	10.000
12.0	12.500	11.25	10.000	13.000	14.000
15.0	15.500	14.25	13.000	16.000	17.000
Centimeters					
Nom. Dia.	"A"	"B"	"C"	"E"	"F"
25.4	21.590	18.415	16.510	22.860	25.400
30.5	31.750	28.575	25.400	33.020	35.560
38.1	39.370	36.195	33.020	40.640	43.180

INSTALLATION & MOUNTING

Light Bases

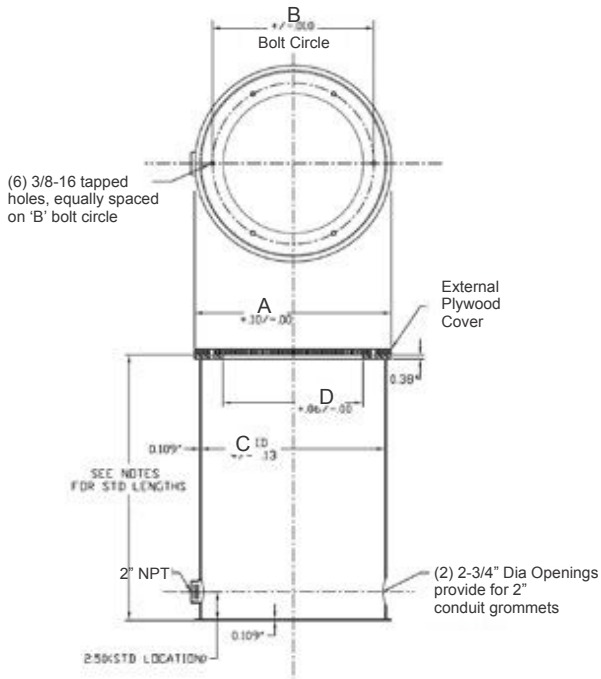

Typical L-867D - All dimensions shown in inches

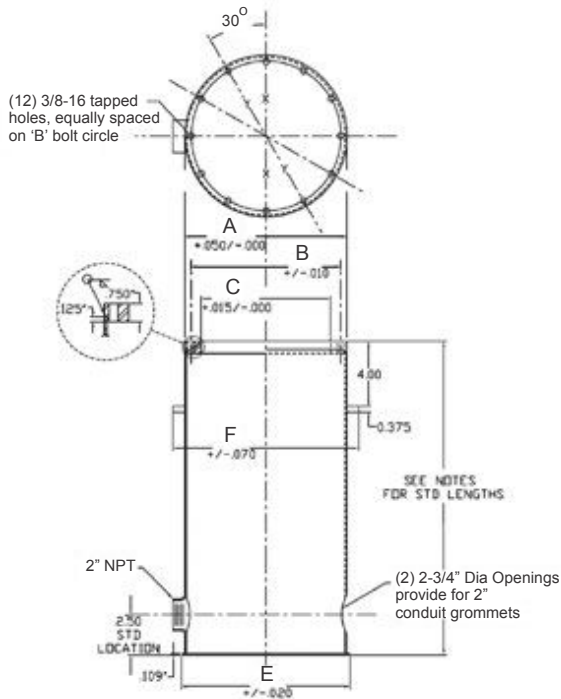

Typical L-868 - All dimensions shown in inches

L-867 Base Plate and Gasket

- Gasket suitable for locations where heat is not present, such as elevated edge lights, edge light extensions, transformer boxes, or junction boxes
- Base plate finish is oxide primer and aviation yellow enamel
- Base plate individually packed with neoprene gasket, steel cable clamp and screws for securing L-823 connector, and assembly instructions
- High-strength 1832RGL base plate is mandatory for FAA L-804 applications and should be used for ICAO applications.

Dimensions - Base Plate

Inches				
Nom. Dia.	"A"	"B"	"C"	"D"
12	12.000	10.250	7.875	0.625
16	16.000	14.250	11.125	0.750
Centimeters				
Nom. Dia.	"A"	"B"	"C"	"D"
30.5	30.48	26.035	20.002	1.588
40.7	40.65	36.195	28.258	1.905

L-867 Base Plate Ordering Code

Base Plate
 19 = 12 in, L-867B
 29 = 16 in, L-867D

Thread Size
 32 = 2 in NPS
 35 = 1.5 in - 12 TPI

Material
 n/a = None
 G = With ground lug

Note: L-867 Base Plate includes gasket.



INSTALLATION & MOUNTING

Light Bases

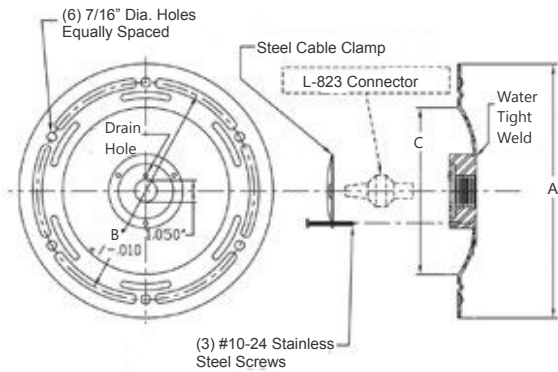

L-867 Base Plate - All dimensions shown in inches

³ Base must have opening at 0° and 180° to allow for draining of the galvanizing materials. A solid grommet will be installed at 180°.

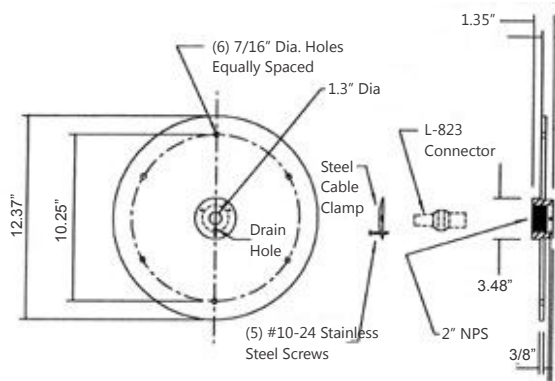

1832RGL Base Plate - All dimensions shown in inches

Dimensions - Neoprene Gasket

Inches			
Nom. Dia.	"A"	"B"	"C"
12	11.938	10.250	9.312
16	15.938	14.250	12.438
24	23.750	21.500	20.000
Centimeters			
Nom. Dia.	"A"	"B"	"C"
30.5	30.232	26.035	23.652
40.7	40.483	36.195	31.593
60.96	60.325	54.610	50.800

Neoprene Gasket Ordering Code

Base Plate
 20 = 12 in, L-867B
 60 = 16 in, L-867D
 70 = 24 in, L-867E

XX 52

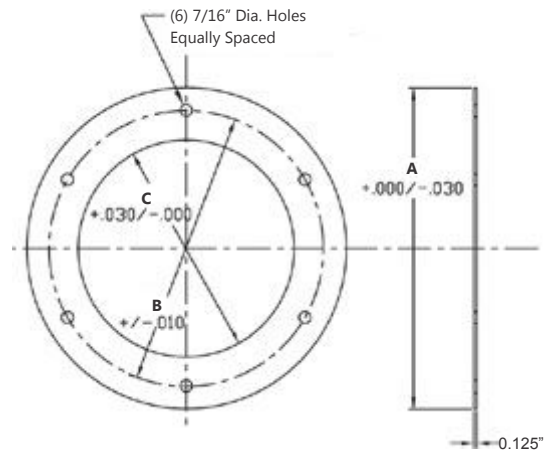

Neoprene Gasket - All dimensions shown in inches

INSTALLATION & MOUNTING

Light Bases

L-867 / L-868 Blank Steel Cover

- "T" = thickness in sixteenths of an inch. Specify thickness when ordering.
- 7/16-inch (1.113 cm) diameter bolt holes have 1-1/8-inch (2.858 cm) diameter counter bore when cover thickness is 0.50 inch (1.27 cm) or greater
- Finish is hot dip galvanized per ASTM A123/A123M-02 and A153
- Blank steel covers do not include bolts or gaskets

Dimensions - L-867 / L-868 Blank Steel Cover

Inches						
Dia. Base	12 L-867	16 L-867	24 L-867	8 L-868	12 L-868	15 L-868
"X" O.D.	13.500	17.375	24.000	8.000	12.000	15.000
"Y" O.D.	10.250	14.250	21.500	7.250	11.250	14.250
"T" (Typ.)	0.375	0.375	0.500	0.750	0.750	1.250
Centimeters						
Dia. Base	30.5 L-867	40.6 L-867	61 L-867	20.3 L-868	30.5 L-868	38.1 L-868
"X" O.D.	34.290	44.133	60.960	20.320	30.480	38.100
"Y" O.D.	26.035	36.195	54.610	18.415	28.575	36.195
"T" (Typ.)	0.953	0.953	0.953	1.905	1.905	3.175

Steel Cover Ordering Code

Diameter

- 1 = 13-1/2 in, L-867B
- 2 = 17-3/8 in, L-867D
- 4 = 12 in, L-868B
- 5 = 15 in, L-868C
- 7 = 24 in, L-867E
- 8 = 8 in, L-868A

Thickness

- 4 = 1/4 in (L-867B only)
- 6 = 3/8 in
- 8 = 1/2 in
- 10 = 5/8 in
- 12 = 3/4 in
- 14 = 7/8 in
- 16 = 1 in
- 18 = 1-1/8 in
- 20 = 1-1/4 in

Material

- (n/a) = Galvanized
- SS = Stainless Steel
- PA = PAR Coated (Class 1B option)

X 000-X-XX

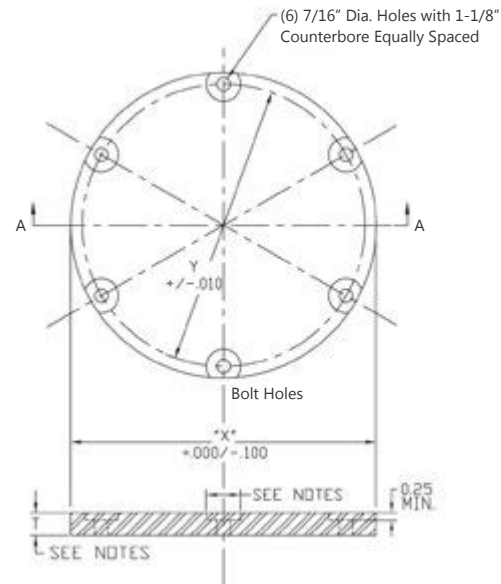

Blank Steel Cover - All dimensions shown in inches

L-868 Flange Ring with Pavement Ring

- "T" = thickness in sixteenths of an inch. Minimum thickness is 0.375 inch (0.953 cm) and maximum thickness is 0.75 inch (1.905 cm). Specify when ordering.
- Finish is hot dip galvanized per ASTM A123/A123M-02 and A153 for flange ring
- Six 3/8-16-inch x "T"-inch + 1 1/4-inch long stainless steel bolts. 3/8-inch locking washers and O-ring gasket shipped with flange ring. If flange ring is to be stacked over spacer ring, please consult ADB Airfield Solutions for a bolt chart to obtain the appropriate bolt length and ordering information.

Dimensions - Flange Ring with Pavement Ring

Inches				
Nom. Dia.	"A"	"B"	"C"	"H"
8"	8.160	7.250	6.500	6.645
12"	12.160	11.250	10.000	10.145
15"	15.160	14.250	13.000	13.145
Centimeters				
Nom. Dia.	"A"	"B"	"C"	"H"
20.3	20.726	18.415	16.510	16.878
30.5	30.798	28.575	25.400	25.768
38.1	38.506	36.195	33.020	33.388

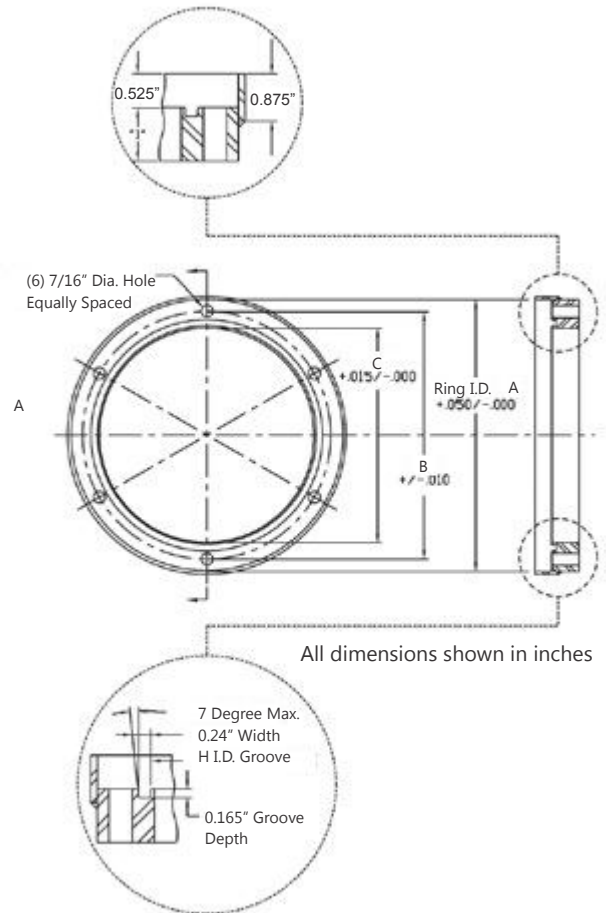

Flange Ring Ordering Code

Diameter

08 = 8 in
54 = 12 in
55 = 15 in

Thickness

4 = 1/4 in
6 = 3/8 in
8 = 1/2 in
12 = 3/4 in

Material

(n/a) = Galvanized
SS = Stainless Steel
PA = PAR Coated (Class 1B option)

XX 02-X Y- XX

