



LED REIL

Runway End Identification Light

User Manual

DM00006-000-01, Rev. v1.7.0, 2026-03-12

**ADB
SAFEGATE**

A.0 Disclaimer / Standard Warranty

CE certification

The equipment listed as CE certified means that the product complies with the essential requirements concerning safety and hygiene. The European directives that have been taken into consideration in the design are available on written request to ADB SAFEGATE.

ETL certification

The equipment listed as ETL certified means that the product complies with the essential requirements concerning safety and C22.2 No.180:13 (R2018) regulations. The CSA directives that have been taken into consideration in the design are available on written request to ADB SAFEGATE.

All Products Guarantee

ADB SAFEGATE will correct by repair or replacement per the applicable guarantee below, at its option, equipment or parts which fail because of mechanical, electrical or physical defects, provided that the goods have been properly handled and stored prior to installation, properly installed and properly operated after installation, and provided further that Buyer gives ADB SAFEGATE written notice of such defects after delivery of the goods to Buyer. Refer to the Safety section for more information on Material Handling Precautions and Storage precautions that must be followed.

ADB SAFEGATE reserves the right to examine goods upon which a claim is made. Said goods must be presented in the same condition as when the defect therein was discovered. ADB SAFEGATE further reserves the right to require the return of such goods to establish any claim.

ADB SAFEGATE's obligation under this guarantee is limited to making repair or replacement within a reasonable time after receipt of such written notice and does not include any other costs such as the cost of removal of defective part, installation of repaired product, labor or consequential damages of any kind, the exclusive remedy being to require such new parts to be furnished.

ADB SAFEGATE's liability under no circumstances will exceed the contract price of goods claimed to be defective. Any returns under this guarantee are to be on a transportation charges prepaid basis. For products not manufactured by, but sold by ADB SAFEGATE, warranty is limited to that extended by the original manufacturer. This is ADB SAFEGATE's sole guarantee and warranty with respect to the goods; there are no express warranties or warranties of fitness for any particular purpose or any implied warranties of fitness for any particular purpose or any implied warranties other than those made expressly herein. All such warranties being expressly disclaimed.

Standard Products Guarantee

Products manufactured by ADB SAFEGATE are guaranteed against mechanical, electrical, and physical defects (excluding lamps) which may occur during proper and normal use for a period of two years from the date of ex-works delivery, and are guaranteed to be merchantable and fit for the ordinary purposes for which such products are made.



Note

See your applicable sales agreement for a complete warranty description.

Replaced or repaired equipment under warranty falls into the warranty of the original delivery. No new warranty period is started for these replaced or repaired products.

FAA Certified products manufactured by ADB SAFEGATE

ADB SAFEGATE L858 Airfield Guidance Signs are warranted against mechanical and physical defects in design or manufacture for a period of 2 years from date of installation, per FAA AC 150/5345-44 (applicable edition).

ADB SAFEGATE LED products (with the exception of obstruction lighting) are warranted against electrical defects in design or manufacture of the LED or LED specific circuitry for a period of 4 years from date of installation, per FAA EB67 (applicable edition). These FAA certified constant current (series) powered LED products must be installed, interfaced and powered with and through products certified under the FAA Airfield Lighting Equipment Program (ALECP) to be included in this 4 (four) year warranty. This includes, but is not limited to, interface with products such as Base Cans, Isolation Transformers, Connectors, Wiring, and Constant Current Regulators.



Note

See your sales order contract for a complete warranty description.

Replaced or repaired equipment under warranty falls into the warranty of the original delivery. No new warranty period is started for these replaced or repaired products.

Liability



WARNING

Use of the equipment in ways other than described in the catalog leaflet and the manual may result in personal injury, death, or property and equipment damage. Use this equipment only as described in the manual.

ADB SAFEGATE cannot be held responsible for injuries or damages resulting from non-standard, unintended uses of its equipment. The equipment is designed and intended only for the purpose described in the manual. Uses not described in the manual are considered unintended uses and may result in serious personal injury, death or property damage.

Unintended uses, includes the following actions:

- Making changes to equipment that have not been recommended or described in this manual or using parts that are not genuine ADB SAFEGATE replacement parts or accessories.
- Failing to make sure that auxiliary equipment complies with approval agency requirements, local codes, and all applicable safety standards if not in contradiction with the general rules.
- Using materials or auxiliary equipment that are inappropriate or incompatible with your ADB SAFEGATE equipment.
- Allowing unskilled personnel to perform any task on or with the equipment.

Copyright Statement

This manual or parts thereof may not be reproduced, stored in a retrieval system, or transmitted, in any form or by any means, electronic, mechanical, photocopying, recording, nor otherwise, without the author's prior written consent.

This manual could contain technical inaccuracies or typographical errors. The author reserves the right to revise this manual from time to time in the contents thereof without obligation of the author to notify any person of such revision or change. Details and values given in this manual are average values and have been compiled with care. They are not binding, however, and the author disclaims any liability for damages or detriments suffered as a result of reliance on the information given herein or the use of products, processes or equipment to which this manual refers. No warranty is made that the use of the information or of the products, processes or equipment to which this manual refers will not infringe any third party's patents or rights. The information given does not release the buyer from making their own experiments and tests.

Table of Contents

1.0 Safety	1
1.1 Safety Messages.....	1
1.1.1 Introduction to Safety.....	2
1.1.2 Intended Use.....	2
1.1.3 Material Handling Precautions : Storage.....	3
1.1.4 Material Handling: Heavy Equipment.....	3
1.1.5 Operation Safety.....	3
1.1.6 Maintenance Safety.....	4
1.1.7 Material Handling Precautions, ESD.....	4
1.1.8 Arc Flash and Electric Shock Hazard.....	5
2.0 Introduction	7
2.1 Runway End Identification Light.....	7
2.2 Dimensions.....	9
3.0 Installation	11
3.1 Installation Safety Considerations.....	11
3.2 Required Equipment	11
3.3 Unpacking.....	12
3.4 Tools and Test Equipment.....	12
3.5 Installation of the LED REIL Assembly.....	12
3.5.1 Specific Site Information	12
3.5.2 Mounting the Control Cabinets.....	13
3.5.3 Mounting Options.....	14
3.5.4 Electrical Connections	18
3.5.5 Horizontal Aiming Adjustments	19
3.5.6 Vertical Aiming Adjustments.....	20
3.6 Installation Checkout	20
3.6.1 Wiring Checkout	20
3.6.2 Connector Checkout.....	21
3.6.3 Safety Switch Checkout	21
3.7 Initial Startup and Preliminary Test	21
3.8 REIL Startup Procedure.....	21
3.9 Calibrating the Current Monitoring Option	22
3.10 Changing the Style of a REIL.....	23
4.0 Operation	25
4.1 Operating Modes.....	25
4.2 CCR Settings and Flash Intensity	26
4.3 Flasher Control PCB EP00007-000-01 Operation.....	27
4.4 Shutdown Procedure	28
5.0 Maintenance and Repair	29
5.1 Maintenance Schedule.....	29
5.1.1 Replacing the LED Light Engine.....	30
5.2 Replacing the Control PCB.....	32
6.0 Troubleshooting	35
6.1 LED REIL Wiring Drawings.....	36
7.0 LED REIL Parts	49
7.1 Major Components.....	50
7.2 Spare Parts	52
A.0 Support	55
A.1 ADB SAFEGATE Website.....	56
A.2 Recycling	57
A.2.1 Local Authority Recycling.....	57
A.2.2 ADB SAFEGATE Recycling.....	57

List of Figures

Figure 1: Typical Layout for REIL.....	13
Figure 2: One-Leg Mounting Configuration	15
Figure 3: One-Leg Mounting Configuration (alt base can mount shown)	15
Figure 4: Two-Leg Mounting Configuration	16
Figure 5: Remote Mounted Head Configuration.....	17
Figure 6: Cabinet Foundation Mounting Dimensions	17
Figure 7: Horizontal Aiming (top view of flash head assembly).....	19
Figure 8: Vertical Aiming	20
Figure 9: Rotary Selector Switch	25
Figure 10: LED Light Engine Replacement Kit AK00014-000-01	31
Figure 11: REIL A-E-C Current Driven Cabinet Interior	32
Figure 12: REIL A-E-C Voltage Driven Cabinet Interior.....	33
Figure 13: Primary Current-Driven LED REIL Internal Wiring Diagram (1 of 2).....	36
Figure 14: Primary Current-Driven LED REIL Internal Wiring Diagram (2 of 2).....	37
Figure 15: Secondary Current-Driven LED REIL Internal Wiring Diagram (1 of 2)	38
Figure 16: Secondary Current-Driven LED REIL Internal Wiring Diagram (2 of 2)	39
Figure 17: Current-Driven LED REIL External Wiring Diagram	40
Figure 18: Primary Voltage-Driven LED REIL Internal Wiring Diagram (1 of 2)	41
Figure 19: Primary Voltage-Driven LED REIL Internal Wiring Diagram (2 of 2)	42
Figure 20: Secondary Voltage-Driven LED REIL Internal Wiring Diagram (1 of 2).....	43
Figure 21: Secondary Voltage-Driven LED REIL Internal Wiring Diagram (2 of 2).....	44
Figure 22: Voltage-Driven LED REIL External Wiring Diagram.....	45
Figure 23: REIL Typical Installation Details.....	46
Figure 24: REIL Typical Installation Details.....	47
Figure 25: REIL Remote Mount Installation Details	48
Figure 26: Side View	50
Figure 27: Enclosure Assembly Front View	50
Figure 28: Component Panel Parts (Voltage Driven)	51
Figure 29: Component Panel Parts (Current Driven).....	51
Figure 30: LED Engine Replacement Kit AK00014-000-01	52

List of Tables

Table 1: L-849 REIL-L Assembly	9
Table 2: Required Equipment Supplied.....	11
Table 3: Required Equipment Not Supplied	11
Table 4: External Power AWG Wire Size	12
Table 5: LED Style A/E/C REIL Modes of Operation.....	25
Table 6: CCR Settings and Flash Intensity	26
Table 7: Control Board Controls and Indicators	27
Table 8: LED REIL Preventative Maintenance Schedule	29
Table 9: LED REIL Troubleshooting Procedures	35
Table 10: Spare Parts	52

1.0 Safety

Introduction to Safety







This section contains general safety instructions for installing and using ADB SAFEGATE equipment. Some safety instructions may not apply to the equipment in this manual. Task- and equipment-specific warnings are included in other sections of this manual where appropriate.

1.1 Safety Messages

HAZARD Icons used in this manual

For all HAZARD symbols in use, see the Safety section. All symbols must comply with ISO and ANSI standards.

Carefully read and observe all safety instructions in this manual, which alert you to safety hazards and conditions that may result in personal injury, death or property and equipment damage and are accompanied by the symbols shown below.

	<p>WARNING</p> <p>Failure to observe a warning may result in personal injury, death or equipment damage.</p>
	<p>DANGER – Risk of electrical shock or ARC FLASH</p> <p>Disconnect equipment from line voltage. Failure to observe this warning may result in personal injury, death, or equipment damage. ARC Flash may cause blindness, severe burns or death.</p>
	<p>WARNING – Wear personal protective equipment</p> <p>Failure to observe may result in serious injury.</p>
	<p>WARNING – Do not touch</p> <p>Failure to observe this warning may result in personal injury, death, or equipment damage.</p>
	<p>CAUTION</p> <p>Failure to observe a caution may result in equipment damage.</p>
	<p>ELECTROSTATIC SENSITIVE DEVICES</p> <p>This equipment may contain electrostatic devices.</p>

Qualified Personnel

	<p>Important Information</p> <p>The term qualified personnel is defined here as individuals who thoroughly understand the equipment and its safe operation, maintenance and repair. Qualified personnel are physically capable of performing the required tasks, familiar with all relevant safety rules and regulations and have been trained to safely install, operate, maintain and repair the equipment. It is the responsibility of the company operating this equipment to ensure that its personnel meet these requirements.</p> <p>Always use required personal protective equipment (PPE) and follow safe electrical work practice.</p>
---	---

1.1.1 Introduction to Safety



CAUTION

Unsafe Equipment Use

This equipment may contain electrostatic devices, hazardous voltages and sharp edges on components

- Read installation instructions in their entirety before starting installation.
- Become familiar with the general safety instructions in this section of the manual before installing, operating, maintaining or repairing this equipment.
- Read and carefully follow the instructions throughout this manual for performing specific tasks and working with specific equipment.
- Make this manual available to personnel installing, operating, maintaining or repairing this equipment.
- Follow all applicable safety procedures required by your company, industry standards and government or other regulatory agencies.
- Install all electrical connections to local code.
- Use only electrical wire of sufficient gauge and insulation to handle the rated current demand. All wiring must meet local codes.
- Route electrical wiring along a protected path. Make sure they will not be damaged by moving equipment.
- Protect components from damage, wear, and harsh environment conditions.
- Allow ample room for maintenance, panel accessibility, and cover removal.
- Protect equipment with safety devices as specified by applicable safety regulations
- If safety devices must be removed for installation, install them immediately after the work is completed and check them for proper functioning prior to returning power to the circuit.

Failure to follow these instructions can result in serious injury, death or equipment damage

Additional Reference Materials



Important Information

- IEC – International Standards and Conformity Assessment for all electrical, electronic and related technologies.
- IEC 60364 – Electrical Installations in Buildings.
- CSA – C22.2 No.180:13 (R2018), series isolating transformers for airport lighting.
- FAA Advisory: AC 150/5340-26 (current edition), Maintenance of Airport Visual Aid Facilities.
- Maintenance personnel must refer to the maintenance procedure described in the ICAO Airport Services Manual, Part 9.
- ANSI/NFPA 79, Electrical Standards for Metalworking Machine Tools.
- National and local electrical codes and standards.

1.1.2 Intended Use



CAUTION

Use this equipment as intended by the manufacturer

This equipment is designed to perform a specific function, do not use this equipment for other purposes

- Using this equipment in ways other than described in this manual may result in personal injury, death or property and equipment damage. Use this equipment only as described in this manual.

Failure to follow this instruction can result in serious injury or equipment damage

1.1.3 Material Handling Precautions : Storage



CAUTION

Improper Storage

Store this equipment properly

- If equipment is to be stored prior to installation, it must be protected from the weather and kept free of condensation and dust.

Failure to follow this instruction can result in equipment damage

1.1.4 Material Handling: Heavy Equipment



DANGER

UNSTABLE LOAD

USE CAUTION WHEN MOVING HEAVY EQUIPMENT

- USE EXTREME CARE WHEN MOVING HEAVY EQUIPMENT.
- VERIFY THAT THE MOVING EQUIPMENT IS RATED TO HANDLE THE WEIGHT.
- WHEN REMOVING EQUIPMENT FROM A SHIPPING PALLET, CAREFULLY BALANCE AND SECURE IT USING A SAFETY STRAP.

FAILURE TO FOLLOW THIS INSTRUCTION CAN RESULT IN DEATH, SERIOUS INJURY, OR EQUIPMENT DAMAGE

1.1.5 Operation Safety



CAUTION

Improper Operation

Do Not Operate this equipment other than as specified by the manufacturer

- Only qualified personnel, physically capable of operating the equipment and with no impairments in their judgment or reaction times, should operate this equipment.
- Read all system component manuals before operating this equipment. A thorough understanding of system components and their operation will help you operate the system safely and efficiently.
- Before starting this equipment, check all safety interlocks, fire-detection systems, and protective devices such as panels and covers. Make sure all devices are fully functional. Do not operate the system if these devices are not working properly. Do not deactivate or bypass automatic safety interlocks or locked-out electrical disconnects or pneumatic valves.
- Protect equipment with safety devices as specified by applicable safety regulations.
- If safety devices must be removed for installation, install them immediately after the work is completed and check them for proper functioning.
- Route electrical wiring along a protected path. Make sure they will not be damaged by moving equipment.
- Never operate equipment with a known malfunction.
- Do not attempt to operate or service electrical equipment if standing water is present.
- Use this equipment only in the environments for which it is rated. Do not operate this equipment in humid, flammable, or explosive environments unless it has been rated for safe operation in these environments.
- Never touch exposed electrical connections on equipment while the power is ON.

Failure to follow these instructions can result in serious injury, death or equipment damage.

1.1.6 Maintenance Safety



DANGER

ELECTRIC SHOCK HAZARD

THIS EQUIPMENT MAY CONTAIN ELECTROSTATIC DEVICES

- DO NOT OPERATE A SYSTEM THAT CONTAINS MALFUNCTIONING COMPONENTS. IF A COMPONENT MALFUNCTIONS, TURN THE SYSTEM OFF IMMEDIATELY.
- DISCONNECT AND LOCK OUT ELECTRICAL POWER.
- ALLOW ONLY QUALIFIED PERSONNEL TO MAKE REPAIRS OR REPLACE MALFUNCTIONING COMPONENTS ACCORDING TO INSTRUCTIONS PROVIDED IN MANUAL.

FAILURE TO FOLLOW THESE INSTRUCTIONS CAN RESULT IN DEATH OR EQUIPMENT DAMAGE

1.1.7 Material Handling Precautions, ESD



CAUTION

Electrostatic Sensitive Devices

This equipment may contain electrostatic devices

- Protect from electrostatic discharge.
- Electronic modules and components should be touched only when this is unavoidable e.g. soldering, replacement.
- Before touching any component of the cabinet you shall bring your body to the same potential as the cabinet by touching a conductive earthed part of the cabinet.
- Electronic modules or components must not be brought in contact with highly insulating materials such as plastic sheets, synthetic fiber clothing. They must be laid down on conductive surfaces.
- The tip of the soldering iron must be grounded.
- Electronic modules and components must be stored and transported in conductive packing.

Failure to follow this instruction can result in equipment damage

1.1.8 Arc Flash and Electric Shock Hazard



DANGER

SERIES CIRCUITS HAVE HAZARDOUS VOLTAGES

THIS EQUIPMENT PRODUCES HIGH VOLTAGES TO MAINTAIN THE SPECIFIED CURRENT - DO NOT DISCONNECT WHILE ENERGIZED.

- ALLOW ONLY QUALIFIED PERSONNEL TO PERFORM MAINTENANCE, TROUBLESHOOTING, AND REPAIR TASKS.
- ONLY PERSONS WHO ARE PROPERLY TRAINED AND FAMILIAR WITH ADB SAFEGATE EQUIPMENT ARE PERMITTED TO SERVICE THIS EQUIPMENT.
- AN OPEN AIRFIELD CURRENT CIRCUIT IS CAPABLE OF GENERATING >5000 VAC AND MAY APPEAR OFF TO A METER.
- NEVER UNPLUG A DEVICE FROM A CONSTANT CURRENT CIRCUIT WHILE IT IS OPERATING; ARC FLASH MAY RESULT.
- DISCONNECT AND LOCK OUT ELECTRICAL POWER.
- ALWAYS USE SAFETY DEVICES WHEN WORKING ON THIS EQUIPMENT.
- FOLLOW THE RECOMMENDED MAINTENANCE PROCEDURES IN THE PRODUCT MANUALS.
- DO NOT SERVICE OR ADJUST ANY EQUIPMENT UNLESS ANOTHER PERSON TRAINED IN FIRST AID AND CPR IS PRESENT.
- CONNECT ALL DISCONNECTED EQUIPMENT GROUND CABLES AND WIRES AFTER SERVICING EQUIPMENT. GROUND ALL CONDUCTIVE EQUIPMENT.
- USE ONLY APPROVED ADB SAFEGATE REPLACEMENT PARTS. USING UNAPPROVED PARTS OR MAKING UNAPPROVED MODIFICATIONS TO EQUIPMENT MAY VOID AGENCY APPROVALS AND CREATE SAFETY HAZARDS.
- CHECK THE INTERLOCK SYSTEMS PERIODICALLY TO ENSURE THEIR EFFECTIVENESS.
- DO NOT ATTEMPT TO SERVICE ELECTRICAL EQUIPMENT IF STANDING WATER IS PRESENT. USE CAUTION WHEN SERVICING ELECTRICAL EQUIPMENT IN A HIGH-HUMIDITY ENVIRONMENT.
- USE TOOLS WITH INSULATED HANDLES WHEN WORKING WITH AIRFIELD ELECTRICAL EQUIPMENT.

FAILURE TO FOLLOW THESE INSTRUCTIONS CAN RESULT IN DEATH OR EQUIPMENT DAMAGE

2.0 Introduction

The ADB Safegate Runway End Identification Light, LED REIL flashing light system provides a visual indication of the runway threshold to pilots during an approach for landing. The system is composed of two sequenced flashers that operate simultaneously to produce short-duration flashes twice a second, one located on each side of the runway threshold. Each LED REIL is composed of an LED optical flash head and an individual control cabinet.

The REIL system may be operated either by local or remote control. There are three styles of REIL systems available to choose from. Style A can be operated at high intensity only, style C can be operated at low intensity only, and style E can be operated at low, medium, or high intensity. The REIL system is available in both voltage powered or a current powered systems. The voltage powered REIL can be operated from a 240 Vac or 120/240 Vac, $\pm 10\%$, 50/60Hz, power supply. The current powered REIL can be operated from a 2.8 to 6.6 A series circuit.



LED REIL - A/C/E

2.1 Runway End Identification Light

Compliance with Standards

FAA:	L-849(L) Style A, C and E AC 150/5345-51 (Current Edition) and the FAA Engineering Brief No. 67. ETL Certified.
ICAO:	Annex 14, Vol. 1, para. 5.3.8
T/C:	Transport Canada TP 312, 5th Edition, Sec. 5.3.10

Uses

LED REIL provides a visual indication to pilots of the runway threshold during an approach.

Style A

- Unidirectional, high intensity, one brightness step

Style C

- Unidirectional, low intensity, one brightness step

Style E

- Unidirectional, three brightness steps

Operating Conditions

Temperature:	-40 °F to +131 °F (-40 °C to +55 °C)
Humidity:	0 to 100% (including conditions where condensation takes place in the form of water or frost)
Altitude:	0 to 10,000 ft (3,000 m)
Wind:	Up to 150 knots
Exposure:	Withstands windblown rain, sand, dust particles, and a salt-laden atmosphere

Optional Features

- On/Off Maintenance Switch Kit 94A0609 – Local switch for removing power to the LED REIL for field maintenance. Installed on the LED REIL enclosure. Available for current-driven only.
- Flange Mount 62B0107/3 – A one-leg enclosure is normally installed onto a threaded coupling, which is attached to the end of a conduit elbow. An optional 6.25-inch (15.88 cm) O.D. flange can be bolted over any conduit elbow flush with the top of the pad.
- Baffle Kit 94A0198-LED – If the standard +15° horizontal beam axis is operationally objectionable on the LED REIL, an optional baffle kit is available. If used, the LED REIL must be set at +3° vertical and +10° horizontal.

Photometric Data

Style	High Intensity (cd)	Medium Intensity (cd)	Low Intensity (cd)
Style A	15,000	N/A	N/A
Style C	N/A	N/A	700
Style E	15,000	1,500	300



Note

Candelas above are within a beam pattern of 10° vertical by 30° horizontal for each flasher. Tolerance of 50% in effective intensity.

Packaging

Styles A/C/E	
Weight	42 lb (19.05 kg) each assembly
Enclosure Dimensions (H x W x D)	16 x 16 x 9 in (40.6 x 40.6 x 22.9 cm)
Packaging Dimensions (H x W x D)	24 x 41 x 29 in (60.96 x 104.14 x 73.66 cm)



Note

Packaging is for information purposes only and is based on one pallet containing one primary and one secondary cabinet and flash head in a box.

Equipment Data

Control	Remote, local, or automatic (when current sensing used)
Flash Rate	120 flashes per minute. Both optical assemblies flash simultaneously with less than a 10-millisecond separation.
Light Beam	Adjustable vertically from 0° to 15° and horizontally 15° each side of the zero reference point. The horizontal scale is in 1° increments and the vertical scale is in 0.5° increments. Nominal setting is +10° vertical and +15° horizontal.
Light Source Locking	A positive locking device prevents accidental movement of LED light assembly after aiming
Mounting	Each LED REIL cabinet with frangible coupling (supplied) can be mounted on a concrete pad with a 2-inch NPT pipe or with an optional floor flange
Enclosure	The cabinets can be padlocked and include an interlock switch to disconnect input power when the cabinet door is open

Power Supply

The LED REIL system operates from a 240 VAC or 120/240 VAC, ±10%, 50/60 Hz power supply. The system can also operate from a series lighting circuit using a 6.6/6.6 A or 20/6.6 A isolation transformer at each unit.

Power Requirements			
Style	Each Unit	Transformer Size	Total
Voltage-powered LED REIL			
A/E	36 VA Average, 119 VA Peak	NA	72 VA Average, 238 VA Peak
C	19 VA Average, 35 VA Peak	NA	38 VA Average, 70 VA Peak
Current-powered LED REIL¹			
A/E	73 VA Average, 161 VA Peak	100 W	146 VA Average, 322 VA Peak ²
C	48 VA Average, 53 VA Peak	30/45 W	96 VA Average, 106 VA Peak ²

2.2 Dimensions

Table 1: L-849 REIL-L Assembly

Dimensions:	16 x 16 x 9 inches (406 x 406 x 229 mm) (enclosure L x H x D)
--------------------	---

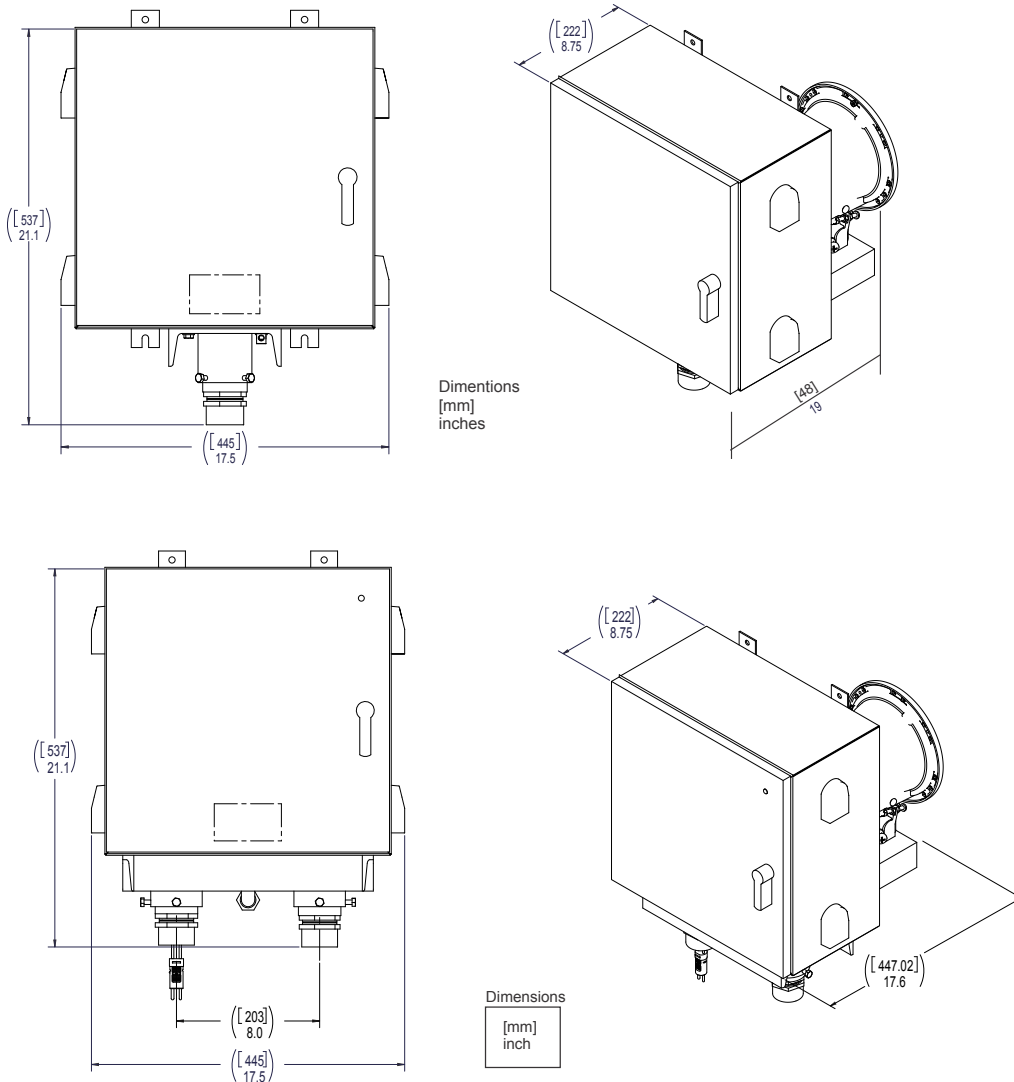

¹ As powered by ferroresonant CCR

² This is total CCR load and includes isolation transformer losses

3.0 Installation

This section provides installation instructions for the LED REIL Runway End Identification Light. Refer to the airport project plans and specifications for site specific installation instructions.

3.1 Installation Safety Considerations



WARNING

Electric Shock

Read installation instructions in their entirety before starting installation.

- Become familiar with the general safety instructions in this section of the manual before installing, operating, maintaining or repairing this equipment.
- Read and carefully follow the instructions throughout this manual for performing specific tasks and working with specific equipment.
- Follow all applicable safety procedures required by your company, industry standards and government or other regulatory agencies.
- Install all electrical connections to local code.
- Use only electrical wire of sufficient gauge and insulation to handle the rated current demand. All wiring must meet local codes.
- Route electrical wiring along a protected path. Make sure they will not be damaged by moving equipment.

Failure to follow these warnings may result in serious injury or equipment damage.

3.2 Required Equipment

Refer to [Table 2](#) for required equipment that is supplied. Refer to [Table 3](#) for required equipment that is not supplied. Refer to the [Parts](#) section for LED REIL assembly ordering information.

Table 2: Required Equipment Supplied

Description	Quantity
Control cabinet with flash head	2 (1 primary and 1 secondary)
Instruction manual	1 per order

Table 3: Required Equipment Not Supplied

Description	Quantity
Wire, input power. Refer to Table 4 .	As required
Wire, remote control (AWG 16 minimum, 600 V)	As required
Wire, trigger signal wire (AWG 16 minimum, 600 V)	As required
Remote control device	As required
Ground rods and AWG 6 solid copper ground wire	As required
External circuit breaker for 120/240 Vac input power	1
Base pads, cement for mounting cabinets	As required
Silicone grease for pipe thread installation	As required
Conduit elbow, 2-in. (50.8 mm) diameter	2
Conduit elbow coupling to attach frangible coupling to elbow	2
Base flange, 6 ¼-in. (158.75 mm) diameter. Not included if conduit elbow coupling is used.	2

Table 3: Required Equipment Not Supplied

Description	Quantity
Level	1
Duct seal	As required

Table 4 provides distance and wire size for incoming power to the REIL.

Table 4: External Power AWG Wire Size

Maximum Distance from Transformer to Individual Control Cabinet			
Feet	Meters	Minimum AWG Wire Size	Minimum Metric Wire Size (sq. mm):
2000	610	10	6.0
1300	396	12	4.0
800	244	14	2.5
500	152	16	1.5

3.3 Unpacking

The equipment is shipped ready for installation. Handle equipment very carefully to prevent component damage. Unpack the carton upon receipt and check the contents and their condition. Note any exterior damage to the carton that might lead to detection of equipment damage.

If you note any damage to any equipment, file a claim with the carrier immediately.

The carrier may need to inspect the equipment.

3.4 Tools and Test Equipment

Conventional tools and test equipment used by general and electrical contractors should suffice for installation. However, a true RMS multi-meter such as a Fluke 87V (or equivalent) and a clamp-on amp probe should be available. A waterproof shroud is needed if a cabinet door has to be opened in extremely inclement weather.

3.5 Installation of the LED REIL Assembly

Unpack the LED REIL, and open the cabinet doors by turning the handle, approximately ¼ turn clockwise to unlock and open the door.



Note

The ADB Safegate LED REIL uses the same enclosure for both the primary and secondary units.

Make sure all components in the enclosures are in place and fastened to the panel assembly. The door interlock switch in the cabinets should be in the OFF position. If all components are in place, close the door, and return the handle to its original position.

3.5.1 Specific Site Information

Site information is provided in the airport project plans and specifications. The installation must conform to the applicable sections of the National Electric Code and local codes.

Refer to the guidelines below when preparing the site. See FAA Advisory Circular AC 150/5340-30, ICAO Annex 14, Vol. 1, paragraph 5.3.8, Transport Canada TP 312, 5th Edition, Sec. 5.3.10, or applicable standards for additional installation requirements.

Figure 1: Typical Layout for REIL

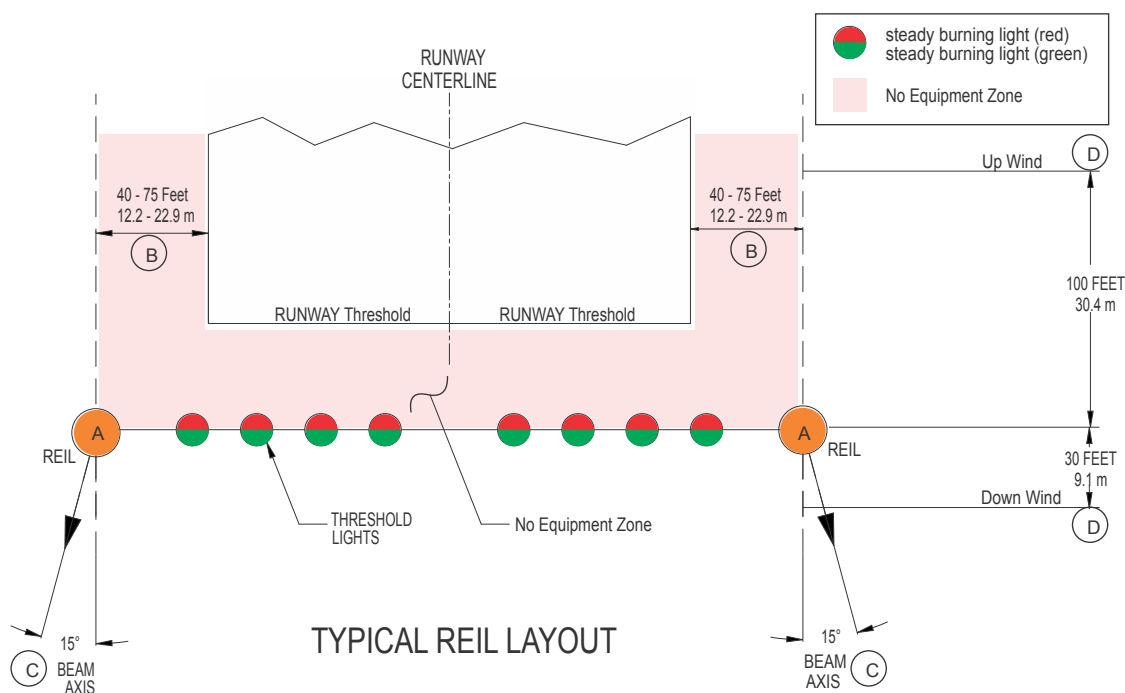

A. The optimum location for each light unit is in line with the runway threshold lights 40 ft [12.1 m] laterally from the runway edge. Space the light units equally from the runway centerline. When adjustments are necessary the difference in the distance of the units from the runway centerline must not exceed 10 ft [3 m]. Locate the REIL equipment a minimum distance of 40ft [12.1 m] from other runways and taxiways. Both REIL units must be at the same elevation and within 3 ft [0.9 m] of the horizontal plane through the runway centerline.

B. If REILs are used with VASI, install REILs 75 ft [22.8 m] from the runway edge. When installed with other glideslope indicators, install REILs 40 ft [12.1 m] from the runway edge if there are concerns with jet blast and wing vortices. See FAA order jo 6850.2 for additional information.

C. The beam centerline (aiming angle) of each light unit is aimed 15 degrees outward from a line parallel to the runway centerline and inclined at an angle 10 degrees above the horizontal. If angle adjustments are necessary, provide an optical baffle and change the angles to 10 degrees horizontal and 3 degrees vertical.

D. A 100 ft [30.4 m] upwind and a 30 ft [9.1 m] downwind longitudinal tolerance is permitted from the runway threshold lights in locating the light units.



Note

For REIL sitting, refer to: FAA AC 150/5340-30 or ICAO Annex 14, Vol. 1, paragraph 5.3.8 as applicable.

3.5.2 Mounting the Control Cabinets

To install the LED REIL, perform the following procedure:



Note

For a voltage driven system: A customer-supplied external circuit breaker should be separately connected to the input power supply lines.

1. Install a customer-supplied 2-inch (50.8 mm) conduit elbow in the concrete pad for external wiring routing into the bottom mounting hub of the cabinet.



Note

Depth of the concrete foundation should be a minimum of 6 in. (152.4 mm) below frost line.

2. Install a customer-supplied 2-inch (50.8 mm) threaded coupling on the threaded end of the conduit elbow.
-



Note

Make sure the coupling is installed level and square with the concrete pad. An alternate method is to use a 6 1/4-inch (158.7 mm) base flange, and bolt the flange to the concrete pad over the conduit elbow flush with top of pad.

When the base flange is used, make sure the flange can be installed level with the concrete pad. Use shims on the flange if further leveling of unit is required. Make sure the conduit is flush with the top of the concrete pad.

3. Coat the threaded end of frangible coupling with silicone grease or anti-seize compound and thread onto the base flange or conduit elbow coupling.
 4. Loosen the hex head screws in the mounting hub and mount cabinet on frangible coupling.
 5. Place a level on the flash head support arm.
-



Note

Level by adjusting slip-fitters on the pipe extending downward from the cabinet.

6. Tighten the hex head screws in the mounting hub against the frangible coupling when the flash head support arm is level.
-



Note

To properly aim the light unit, the flash head support arm must be level and parallel to the runway centerline when the cabinets are installed.

7. Tighten the hex head screws against the hub.

3.5.3 Mounting Options

One-Leg Mounting Examples

See [Figure 2](#) and [Figure 3](#).

Figure 2: One-Leg Mounting Configuration

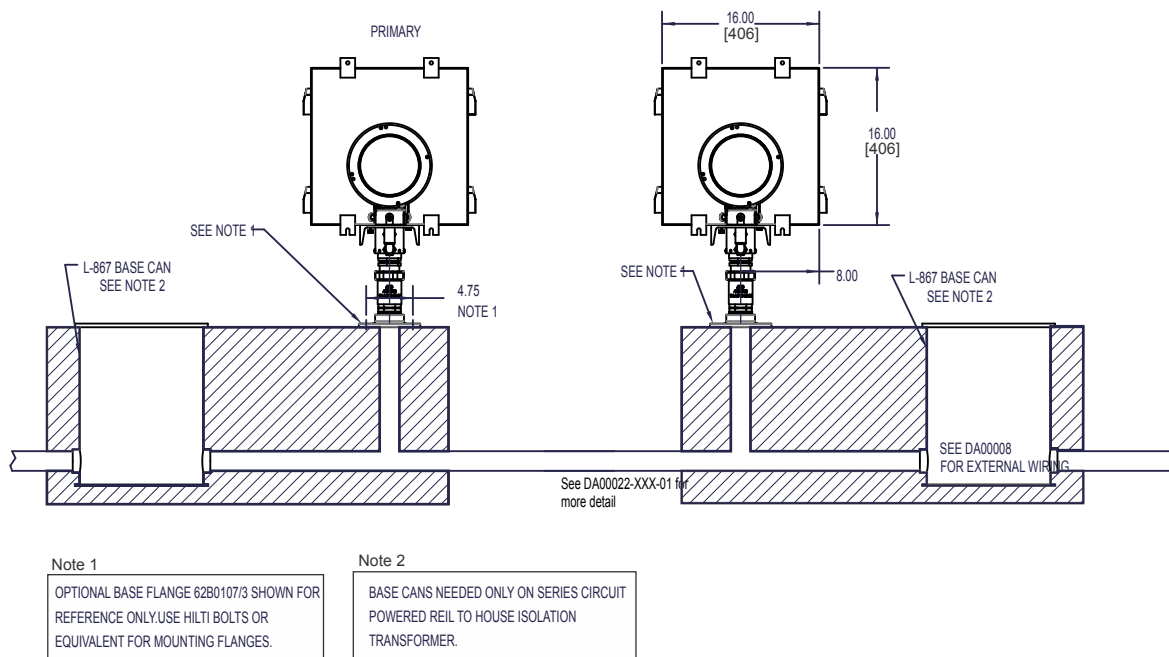

Note

Mount the LED REIL assembly directly onto the frangible coupling supplied with the assembly.



Note

The Overall Height of the Optical Assembly SHALL NOT exceed 34 inches.



Note

Figure 2 is given only as guide. Check local codes and the airport project plans and specifications for installation requirements. See FAA AC 150/5345-51 (Current Edition) for additional mounting instructions.

Figure 3: One-Leg Mounting Configuration (alt base can mount shown)

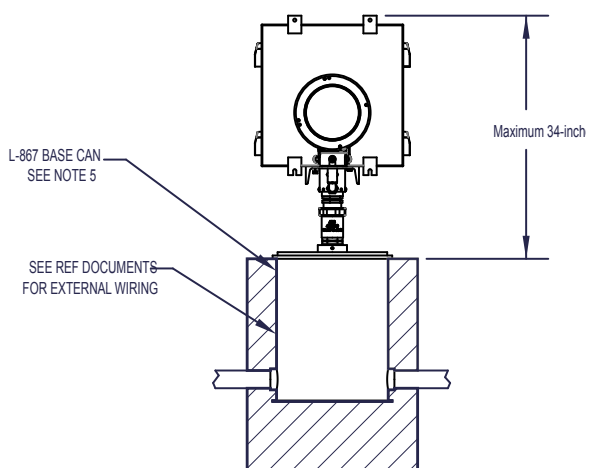

Two-Leg Mounting Examples

See Figure 4.

Figure 4: Two-Leg Mounting Configuration

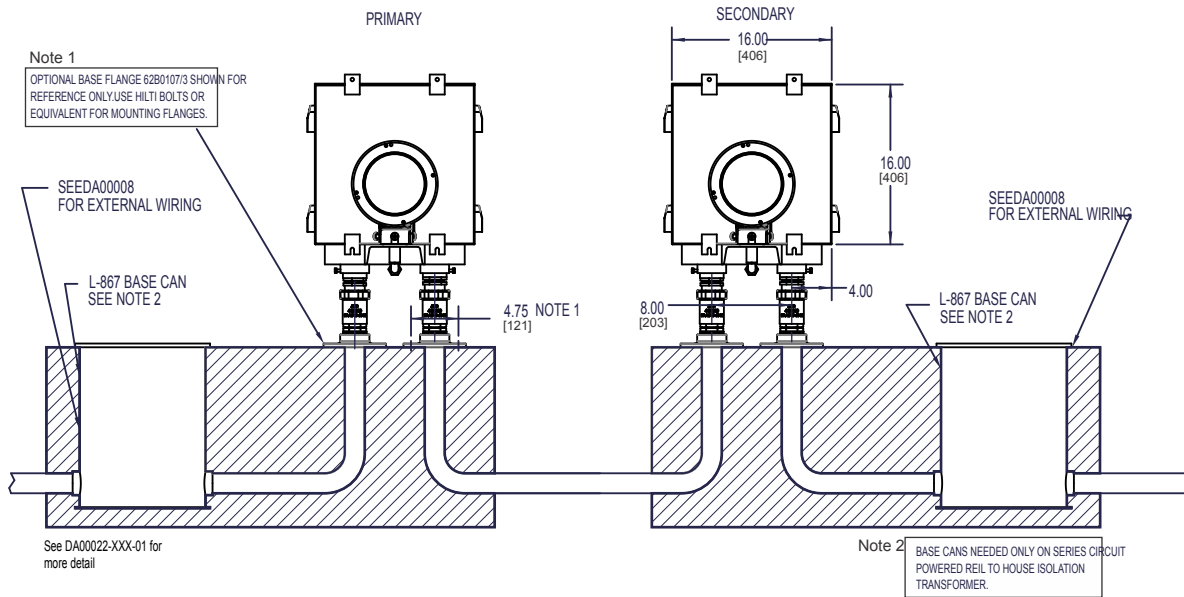

Note

Mount the LED REIL assembly directly onto the frangible coupling supplied with the assembly.



Note

The Overall Height of the Optical Assembly SHALL NOT exceed 34 inches.



Note

Figure 4 is given only as guide. Check local codes and the airport project plans and specifications for installation requirements. See FAA AC 150/5345-51 (Current Edition) for additional mounting instructions.

Figure 5: Remote Mounted Head Configuration

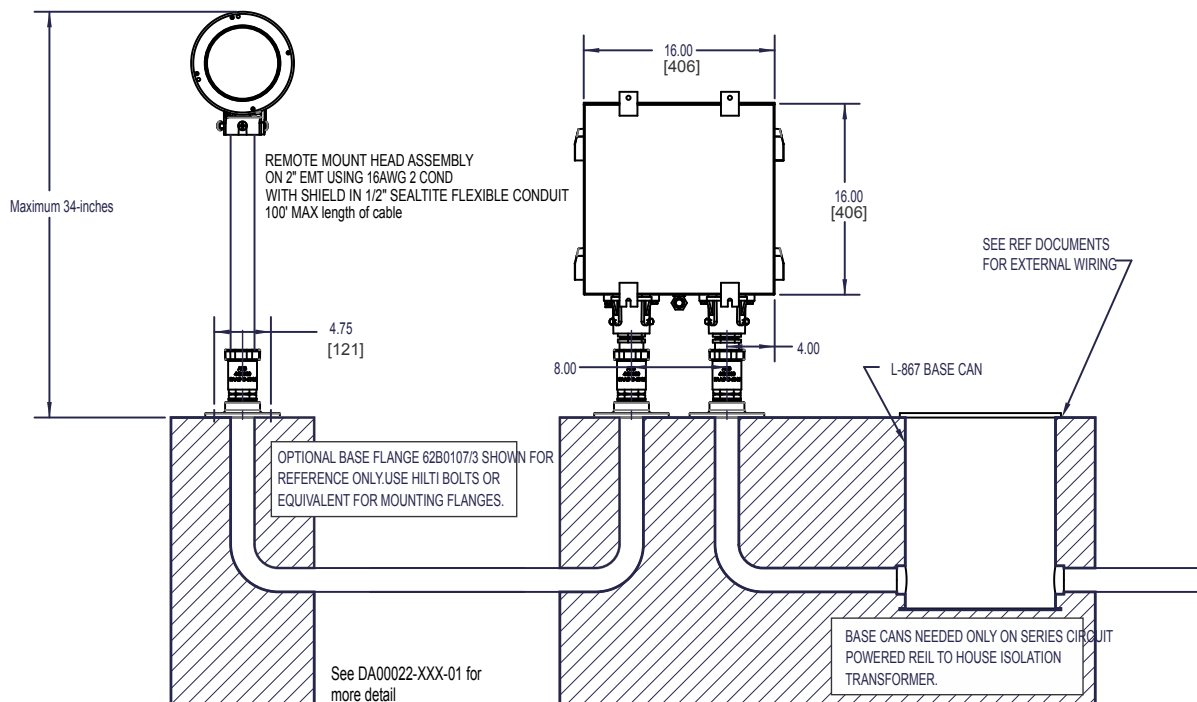

Note

Figure 5 is given only as guide. Check local codes and the airport project plans and specifications for installation requirements. See FAA AC 150/5345-51 (Current Edition) for additional mounting instructions.

Concrete foundation specs

- Concrete foundation at 20" wide (for both single-leg and two-leg) and a minimum depth of 24 in. or 12" below frost line (whichever is greater). This is the standard for PAPI installation.
- Conduit depth (elbow) is 18" minimum depth.
- Consult AC/150-5340-30 for complete specifications.

Concrete Foundation Examples

Figure 6: Cabinet Foundation Mounting Dimensions

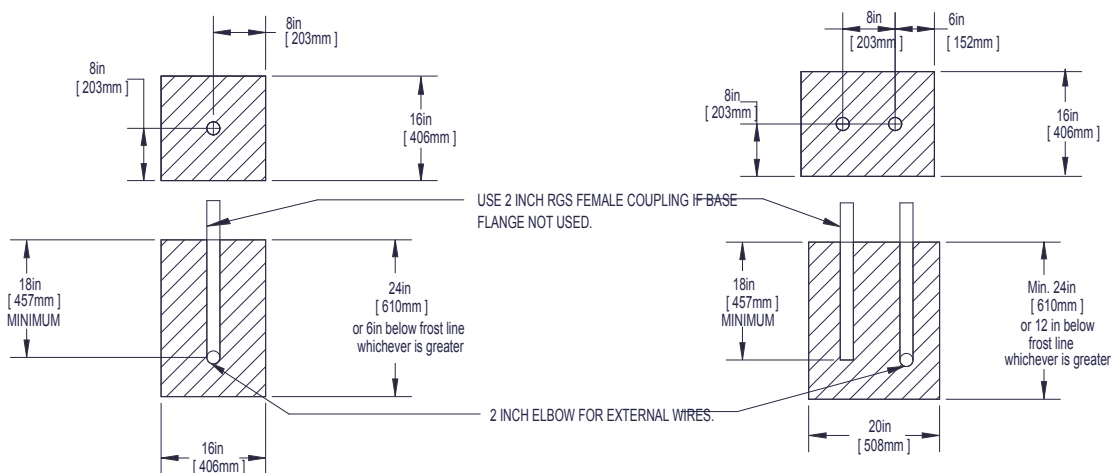

3.5.4 Electrical Connections

See [LED REIL Wiring Drawings](#) for external wire connections to the flash units.



Note

All electrical wiring must be made in accordance with the applicable local electrical codes.

Wiring between the flash head and the individual control cabinet is connected and supplied with the unit. Proper wire size information for the external connections is given in [Table 4](#). Although ADB Safegate L-849(L) units are provided with input lightning protection, it is recommended that supplementary external lightning arrestors be added to incoming power lines as local conditions require.



WARNING

Disconnect power to the lighting circuit before attempting to make any electrical connections. Coordinate a power outage with air traffic personnel before turning power to the airport lighting system off.

Failure to observe a warning may result in personal injury, death or equipment damage.

For Current Driven LED REILs

Install a L-867 base can to house the L-830 or L-831 isolation transformer.

Connection to Grounded Isolation Transformers

If grounded isolation transformers are used, ensure that the earth-grounded leg of the isolation transformer is connected to position TB1-2 of the REIL unit's input power terminal block. See L-849V Style A/E/C (REIL) Current Driven External Wiring for details.

See [Figure 13](#).

For Voltage-Driven REILs that Use Current Sensing for the Remote Control

Install a L-867 base can next to the primary unit.

Grounding The LED REILs

See [Figure 18](#). Ground the Primary and Secondary Units by connecting a No. 6 bare solid copper wire at the earth ground lug provided inside the cabinets (hinged side) and route the wire through the conduit to the grounding rod. The ground resistance shall not exceed 25 ohms with the power feeder neutral disconnected. If necessary, additional ground rods shall be installed and interconnected to obtain the required resistance. The ground wires shall be connected to the ground rods by either an exothermic process (Erico Products Corporation, Cadweld, Burndy Corporation, Thermoweld or equivalent) or by brazing.



CAUTION

Pipe straps shall not be used for grounding purposes. Ground connections and lugs must be the best commercial type.

Cabinet and Remote Control Wiring

Refer to the guidelines below when wiring the cabinet and the remote control.

1. Disconnect power to the lighting circuit.
 2. Install interconnecting power and control wiring (AWG 16 minimum, 600 V) between terminal block TB1 and TB2 in each cabinet. See [Figure 13](#) and [Figure 20](#).
-



CAUTION

It is important for proper operation that the cable for the reset wiring be shielded.



Note

If the current sensing option is not used, make remote control circuitry connections (AWG 16 minimum, 600 V) to Primary terminal block TB2 terminals 11 through 13. When the current sensing option is used, remote control is not possible and terminals TB2, 8 through 13 are not used.

3. Check for proper installation and firm connections.
-

4. Tighten all connections.
5. Seal all conduit entries with duct seal to prevent insect and moisture ingress.

3.5.5 Horizontal Aiming Adjustments



Note

Refer to the guidelines below when preparing the site. See FAA Advisory Circular AC 150/5340-30, ICAO Annex 14, Vol. 1, paragraph 5.3.8, Transport Canada TP 312, 5th Edition, Sec. 5.3.10, or applicable standards for additional installation requirements.

To adjust the horizontal setting, perform the following procedure:

1. See [Figure 7](#). Using a 9/16-inch open end or box wrench loosen all 3 hex head adjustment screws and 3 jam nuts. Manually rotate the head assembly and orientate the beam axis of the flash head to a maximum of 15 degrees outward from a line parallel to the runway centerline. Reference [Figure 1](#).

Figure 7: Horizontal Aiming (top view of flash head assembly)

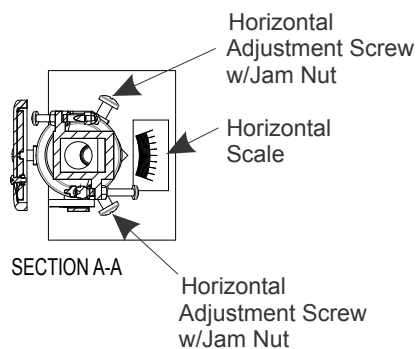

2. Hand-tighten all 3 screws and jam nuts when adjustment is completed. Check the alignment pointer to verify that the required horizontal angle is correct. Repeat the adjustment procedure if the angle is not correct.

3.5.6 Vertical Aiming Adjustments



Note

Refer to the guidelines below when preparing the site. See FAA Advisory Circular AC 150/5340-30, ICAO Annex 14, Vol. 1, paragraph 5.3.8, Transport Canada TP 312, 5th Edition, Sec. 5.3.10, or applicable standards for additional installation requirements.

To adjust the vertical setting, perform the following procedure:

Figure 8: Vertical Aiming

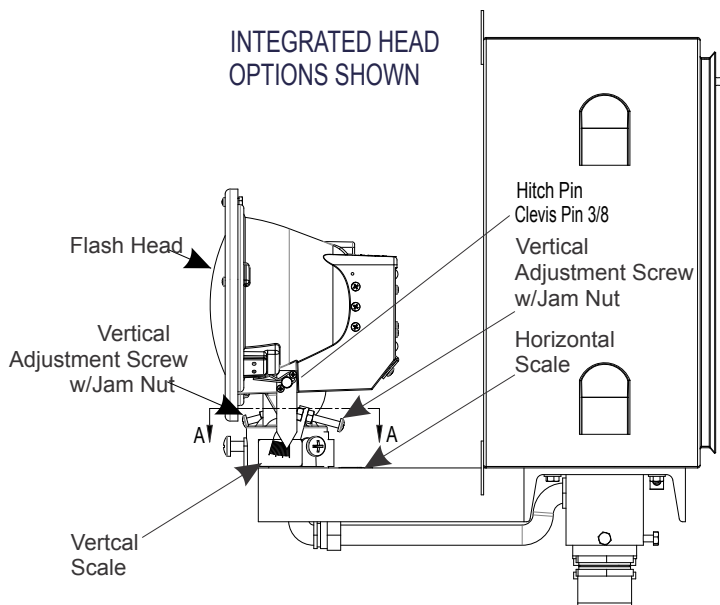

1. See [Figure 8](#). Loosen the two adjustment hex set screws and jam nut using a 7/16-inch open end or box wrench so that both set screws are not in contact with the head. One vertical adjustment screw is located on the backside of the fixture, as shown in [Figure 8](#), and the other adjustment screw is location on the front side of the fixture.
2. Manually pivot the head assembly backward or forward to adjust the vertical beam setting to the required angle above horizontal. 15 Degrees maximum.
3. Holding the head assembly at the selected vertical angle on the scale, tighten the 2 hex bolts up against the flash head assembly and then tighten the two jam nuts to lock the adjustment screws against the head assembly. Check the alignment pointer to verify that the required vertical angle is correct. Repeat the adjustment procedure if the angle is not correct.

3.6 Installation Checkout

This section describes procedures for installation checkout. See [Wiring Schematics](#) section.

3.6.1 Wiring Checkout

Refer to the guidelines below when checking out wiring.



WARNING

All power should be off while resistance checks are being made. A potential of 240 Vac may be present, which can be lethal.

Failure to observe a warning may result in personal injury, death or equipment damage.

- All grounding connections to equipment, housing, structures, and ground rods shall be thoroughly checked. The ground resistance of all ground rods shall be within the limits specified in project plans and specifications.

- All power and control wiring shall be carefully and thoroughly verified. Using an ohmmeter, check all wires to make sure that proper connections are made.

3.6.2 Connector Checkout

Carefully check all connections and wiring disconnects for proper mating. Check all terminal board connections for tightness.

3.6.3 Safety Switch Checkout

Check the Primary and Secondary cabinets and flash heads for complete closure and latching, making sure that the interlock safety switches are depressed.



CAUTION

If the system is turned on and wiring is connected improperly, all or part of the system can be damaged and void the warranty.

3.7 Initial Startup and Preliminary Test



WARNING

Before applying power to any part of the system, carefully read and observe at all times the safety instructions in the *Safety* section in this manual.

Failure to observe a warning may result in personal injury, death or equipment damage.

Refer to the guidelines below upon initial startup and preliminary testing.

In each LED REIL control cabinet verify that the control switches are set to OFF. Turn on power to the REIL (for voltage-powered REILs engage external circuit breaker, for current-powered REILs turn on the CCR) and verify that the following is present on TB1 in the control cabinet: See the [wiring diagrams](#).

1. Current-Powered REIL: Place a clamp-on ammeter probe around TB1-14. Ensure 2.8A to 6.6A (for 5-step CCRs) or 4.8A-6.6A (for 3-step CCRs) is present and matches the CCR step setting.
2. Voltage-Powered REIL: For 120/240Vac powered REILs, verify the following voltages are present in both primary and secondary REIL cabinets:
 - TB1-1 to TB1-3: 120Vac
 - TB1-1 to TB1-2: 120Vac
 - TB1-2 to TB1-3: 240Vac
3. Voltage-Powered REIL: For 240VAC powered REILs, verify the following voltage is present in both primary and secondary REIL cabinets:
 - TB1-2 to TB1-3: 240Vac
4. If the optional external failure indicator is used, set the Misfire Threshold switch SW1 on the Flasher Control Board to the desired consecutive misfire alarm level. SW1 may be set from 1 to 7. Set SW1 to zero if the external failure indicator is not used.



Note

Changing Step Modes (Primary only) Only the Primary Unit requires programming.

5. Turn the Primary unit ON.

3.8 REIL Startup Procedure

- Make sure that the rotary control switch on Primary oscillator PCB in the control cabinets is set to:
 - REMOTE position for remote (voltage powered only) or current sensing operation. -OR-
 - ON position for local operation for Style A/C REIL.
 - LOW, MED or HI position for local operation for Style E REIL.

- Make sure that the Primary and Secondary cabinet doors are properly closed to activate interlock switch on the door. For voltage driven units, the REIL system should start flashing when the external circuit breaker is engaged (power is supplied to the input power terminals of the Primary and Secondary).
For current driven units with current sensing: the REIL system will start flashing when the series circuit is energized for both the Primary and Secondary using the desired current step set in the procedure [current monitoring](#).
-



Note

Only the Primary Unit requires calibration.

3.9 Calibrating the Current Monitoring Option

For Style A/E/C unit with the current sensing option:

1. Turn the series field circuit on.
 2. Set the constant current regulator (CCR) to the lowest desired step for the REIL to be in operation.
 3. In the primary light unit, set the rotary switch to the REMOTE position.
 4. Find the control board, EP00007-000-01 and locate the CURRENT ADJUST buttons and LED indicators.
 - For style A REIL, the CCR should be set to B4 (or B100). Press the SET HIGH button for 4 seconds, the HIGH LED D20 will light for 4 seconds and turn off. Release the button.
 - For style C REIL, the CCR should be set to B1 (or B10). Press the SET LOW button for 4 seconds, the LOW LED D18 will light for 4 seconds and turn off. Release the button.
 - For style E REIL, the CCR should be set to B1 (or B10). Press the SET LOW button for 4 seconds, the LOW LED D18 will light for 4 seconds and turn off. Release the button. Set the CCR to step B3 (or B30). Press the SET MED button for 4 seconds, the MED LED D19 will light for 4 seconds and turn off. Release the button. Set the CCR to step B4 (or B100). Press the SET HIGH button for 4 seconds, the HIGH LED D20 will light for 4 seconds and turn off. Release the button.
 5. The REIL is now programmed to operate at the desired current step and the desired intensity. The REIL will not operate at lower current steps than what it is calibrated.
-



Note

Any deviation from this calibration will require a larger isolation transformer for operation.

- Style A and Style E operate at high-intensity. For high-intensity operation the regulator must be set to step B4 or B5 (or B100). If high-intensity operation is desired at a lower step, a 200 W or 300 W isolation transformer is required.
 - Style E also operate at medium-intensity. For medium intensity operation the regulator must be set to B3 (or B30). If medium-intensity operation is desired at a lower step, a 200 W or 300 W isolation transformer is required.
 - Style C operates at low-intensity only. For low-intensity operation the regulator can be set to any step for operation. A 30/45 W transformer is required.
-
-



Note

To restore default settings:

- For Style A, press and hold the SET MED and SET HIGH buttons together for 4 seconds. The LOW LED D18 will blink for 4 seconds and turn off. Release the buttons.
 - For Style C, press and hold SET LOW and SET HIGH buttons together for 4 seconds. The MED LED D19 will blink for 4 seconds and turn off. Release the buttons.
 - For Style E, press and hold SET LOW, SET MED, and SET HIGH buttons together for 4 seconds. The LOW, MED, and HIGH LEDs D18, D19, and D20 will blink for 4 seconds and turn off. Release the buttons.
-

3.10 Changing the Style of a REIL

Overview

It is not common to change the style of an LED REIL from its factory configuration. However, if this is necessary, one firmware is used to configure all LED REILs for Style A, E, and C, therefore the style can easily be changed.

To configure the LED REIL, in the primary light unit only, locate the CURRENT ADJUST buttons and LED indicators on the control board EP00007-000-01.

- To configure to Style A, press and hold the SET MED and SET HIGH buttons together for 4 seconds. The LOW LED D18 will blink for 4 seconds and turn off. Release the buttons.
- To configure to Style C, press and hold SET LOW and SET HIGH buttons together for 4 seconds. The MED LED D19 will blink for 4 seconds and turn off. Release the buttons.
- To configure to Style E, press and hold SET LOW, SET MED, and SET HIGH buttons together for 4 seconds. The LOW, MED, and HIGH LEDs D18, D19, and D20 will blink for 4 seconds and turn off. Release the buttons.



CAUTION

Do not use this section to change the style of REIL from a Style A or C to a Style E, or from a Style E to a Style A or C. If this change is necessary, contact ADB Safegate factory for assistance.

Changing to a Style A

- In the primary light unit only, locate the CURRENT ADJUST buttons and LED indicators on the control board EP00007-000-01.
- Press and hold the SET MED and SET HIGH together for 4 seconds. The LOW LED D18 will blink for 4 seconds and turn off. Release the buttons.
- Set the constant current regulator (CCR) to the step setting where REIL operation is desired.



Note

Style A operates at high-intensity only. For high-intensity operation the regulator must be set to step B4 or B5 (or B100). If high-intensity operation is desired at a lower step, a 200 W or 300 W isolation transformer is required.

- In the primary light unit only, turn the rotary switch to the "REMOTE" position.
- Press the SET HIGH button for 4 seconds, the HIGH LED D20 will blink for 4 seconds and turn off. Release the button.
- The board is now programmed for the desired current to activate the unit. The REIL will not operate at lower current steps.

Changing to a Style C

- In the primary light unit only, locate the CURRENT ADJUST buttons and LED indicators on the control board EP00007-000-01.
- Press and hold the SET LOW and SET HIGH together for 4 seconds. The MED LED D19 will blink for 4 seconds and turn off. Release the buttons.
- Set the constant current regulator (CCR) to the step setting where REIL operation is desired.



Note

Style C operates at low-intensity only. For low-intensity operation the regulator can be set to any step for operation. A 30/45 W transformer is required.

- In the primary light unit only, turn the rotary switch to the "REMOTE" position.
- Press the SET LOW button for 4 seconds, the LOW LED D18 will blink for 4 seconds and turn off. Release the button.
- The board is now programmed for the desired current to activate the unit. The REIL will not operate at lower current steps.

Changing to a Style E

- In the primary light unit only, locate the CURRENT ADJUST buttons and LED indicators on the control board EP00007-000-01.
- Press and hold the SET HIGH, SET MED and SET LOW buttons for 4 seconds. The LOW, MED and HIGH LEDs D18, D19, and D20 will all blink for 4 seconds and turn off. Release the buttons.
- In the primary light unit only, turn the rotary switch to the "REMOTE" position.
- **For 5 step regulators:** Set the constant current regulator (CCR) to step B1, push the SET LOW push button for 4 seconds, the LOW LED D18 will light for 4 seconds and turn off, release the button. Set the CCR to step B3, push the SET MED push button for 4 seconds, the MED LED D19 will light for 4 seconds and turn off, release the button. Set the CCR to step B4, push the SET HIGH push button for 4 seconds, the HIGH LED D20 will light for 4 seconds and turn off, release the button.
- **For 3-step regulators:** Set the CCR to B10, push the SET LOW push button for 4 seconds, the LOW LED D18 will light for 4 seconds and turn off, release the button. Set the CCR to B30, push the SET MED push button for 4 seconds, the MED LED D19 will light for 4 seconds and turn off, release the button. Set the CCR to B100, push the SET HIGH push button for 4 seconds, the HIGH LED D20 will light for 4 seconds and turn off, release the button.

4.0 Operation



WARNING

Improper Operation

- Read the instructions in their entirety before starting installation.
- Allow only qualified personnel to perform the following tasks. Observe and follow the safety instructions in this document and all other related documentation.

Failure to observe a warning may result in personal injury, death or equipment damage.

This section provides instructions for operating the LED REIL.

The LED REIL system may be operated by local or remote control. Remote control is by switch or radio receiver/decoder unit. For maintenance purposes, a rotary selector switch is provided inside the Primary individual control cabinet for local control.

4.1 Operating Modes

Refer to [Table 5](#). A rotary selector switch can be found in the control cabinet of the primary light unit. The switch found in the Style A/C LED REILs has 3 settings: REMOTE, OFF and ON. The rotary switch found in the Style E has 5 settings: REMOTE, OFF, LOW, MED, HIGH. This switch determines if the flashing lights are controlled locally or by a remote control. The REMOTE setting on the rotary selector switch turns control of the system over to a remote control system that can turn the flashing lights on or off.

Table 5: LED Style A/E/C REIL Modes of Operation

Rotary Selector Switch Position (Primary Cabinet)	Remote Control Panel Setting	Operational Results	Note
ON	All settings	Flashers operate	Style A/E/C
OFF	All settings	System off - no flashing	Style A/E/C
REMOTE	OFF	System off - no flashing (except when current sensing is present)	Style A/E/C
LOW, MED, HIGH	ON	Flashers operate (low, med, high)	Style E Only

Figure 9: Rotary Selector Switch



Style A and C

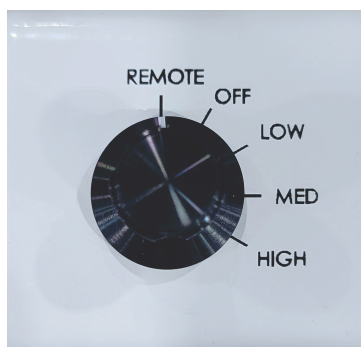

Style E

4.2 CCR Settings and Flash Intensity

The flash intensity levels defined in [Table 6](#) are the default configuration of the LED REIL and prescribed in FAA AC 150/5345-51 (current edition). The LED REIL can be custom configured to meet the unique operational needs of the airport. To custom configure the LED REIL refer to the section [Calibrating the Current Monitoring Option](#) for instructions on how to calibrate flash intensity to a desired CCR current.



Note

Any deviation from this calibration will require a larger isolation transformer for operation.

- Style A and Style E operate at high-intensity. For high-intensity operation the regulator must be set to step B4 or B5 (or B100). If high-intensity operation is desired at a lower step, a 200 W or 300 W isolation transformer is required.
- Style E also operate at medium-intensity. For medium intensity operation the regulator must be set to B3 (or B30). If medium-intensity operation is desired at a lower step, a 200 W or 300 W isolation transformer is required.
- Style C operates at low-intensity only. For low-intensity operation the regulator can be set to any step for operation. A 30/45 W transformer is required.

Table 6: CCR Settings and Flash Intensity

Runway Lighting Circuit	CCR Current	Flashing Equipment Intensity Level
Medium Intensity Runway Lighting		3 Step Regulator
	6.6 A (B100)	High Intensity
	5.5 A (B30)	Medium Intensity
	4.8 A (B10)	Low Intensity
High Intensity Runway Lighting		5 Step Regulator
	6.6 A (B5)	High Intensity
	5.2 A (B4)	High Intensity
	4.1 A (B3)	Medium Intensity
	3.4 A (B2)	Low Intensity
	2.8 A (B1)	Low Intensity

4.3 Flasher Control PCB EP00007-000-01 Operation

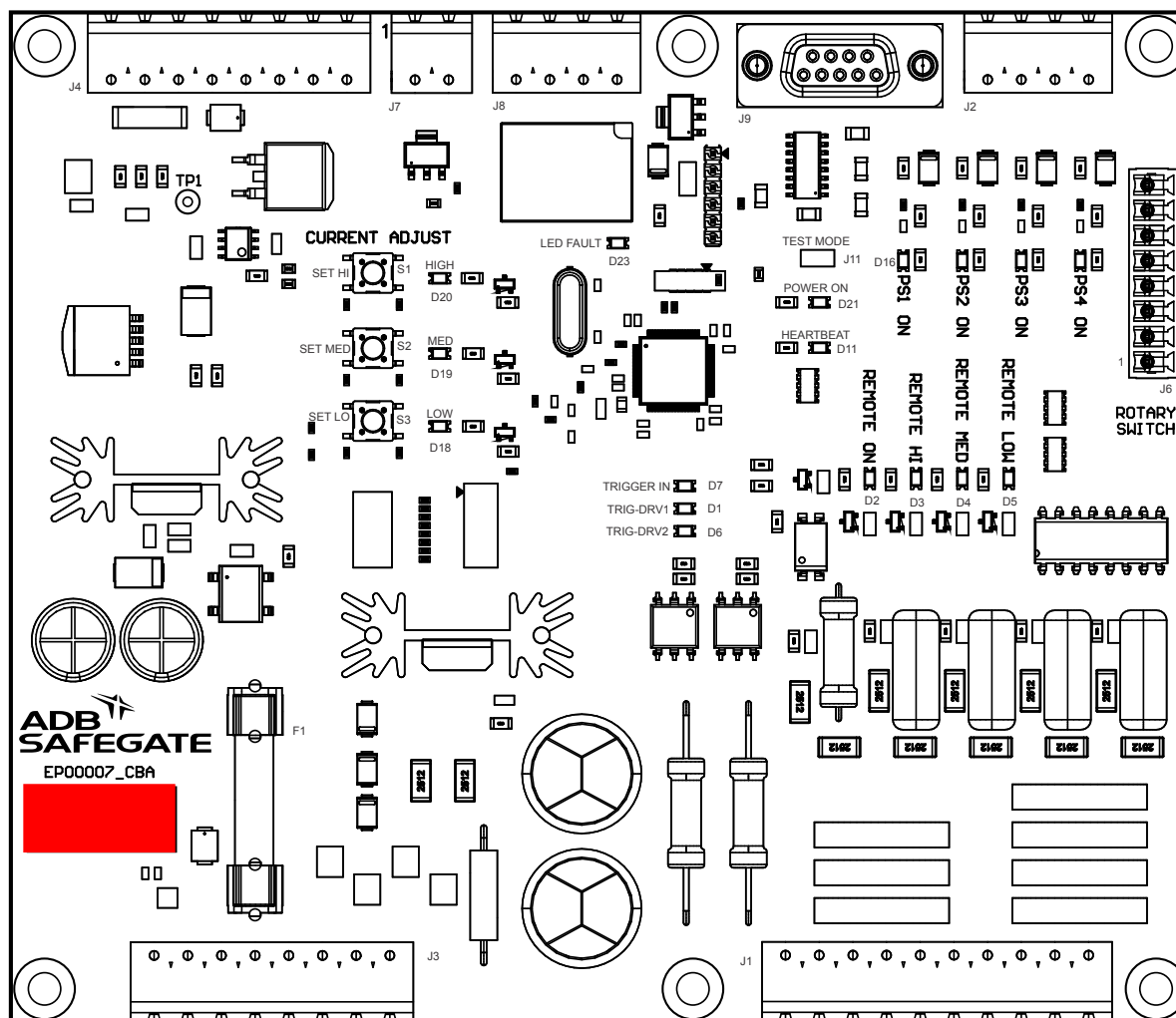

Table 7: Control Board Controls and Indicators

ID	Name	Indication	Description
D1	Trigger Driver 1	Green	Activated on the Primary Unit only. Flashes when a trigger pulse is output from the Primary Unit.
D6	Trigger Driver 2	OFF	Not used for REIL applications.
D7	Trigger In	Green	Activated on the Secondary Unit only. Flashes when a trigger pulse is received from the Primary Unit.
D2	Remote On	Green	Illuminates when a Remote-On command has been input into the unit.
D3	Remote High	Green	Illuminates when a Remote-High intensity command has been input into the unit.
D4	Remote Med	Green	Illuminates when a Remote-Medium intensity command has been input into the unit. Not used in a Style A or C REIL.
D5	Remote Low	Green	Illuminates when a Remote-Low intensity command has been input into the unit. Not used in a Style A or C REIL.
D16	PS1 On	Green	Illuminates when power is being output to LED Power Supply PS1.

Table 7: Control Board Controls and Indicators

ID	Name	Indication	Description
D23	LED Fault	Green	Illuminates on a PS1 fault.
S3	Low	--	Low intensity Current Sensing adjustment control. Not used in a Style A REIL.
S2	Med	--	Medium intensity Current Sensing adjustment control. Not used in a Style A REIL.
S1	High	--	High intensity Current Sensing adjustment control.
D18	Low	Green	Illuminates when the circuit is operating in the Low current setting and operating within the proper current range. Not used in a Style A or C REIL.
D19	Medium	Green	Illuminates when the circuit is operating in the Medium current setting and operating within the proper current range. Not used in a Style A or C REIL.
D20	High	Green	Illuminates when the circuit is operating in the High current setting and operating within the proper current range.
D21	Power On	Green	Illuminates when the +5VDC power supply is operating properly on the Control board.
D11	Heartbeat	White	Blinks when the REIL is operating.

4.4 Shutdown Procedure

When it is necessary to shut down the control cabinet, open the cabinet door and place the ON/OFF switch in the OFF position. (Once the door is opened the unit will shut off because the door switch has changed state) When the entire system is to be shut down, disengage the external circuit breaker (voltage units) or place the ON/OFF switch in both control cabinets in the OFF position.

5.0 Maintenance and Repair



WARNING

Electric Shock

- Read the instructions in their entirety before starting maintenance.
- Allow only qualified personnel to perform the following tasks. Observe and follow the safety instructions in this document and all other related documentation.

Failure to observe a warning may result in personal injury, death or equipment damage.

This section provides preventive maintenance for the LED REIL, Runway End Identification Light system.

5.1 Maintenance Schedule

To keep the LED REIL system operating efficiently, follow the recommended preventive maintenance schedule. Refer to [Table 8](#).

Table 8: LED REIL Preventative Maintenance Schedule

Interval	Maintenance Task	Action
Daily	Visually check the system is operating and for proper flashing sequence.	If unit is malfunctioning, follow Troubleshooting procedures.
Every 2 Weeks	Visually check the flash head lens for cleanliness.	Clean as necessary.
	Visually check the flash head lens for signs of moisture, or condensation.	If moisture or condensation is present, check lens gasket for damage and check flash head for signs of ingress. Repair or replace gasket or flash head components as necessary.
	Visually check individual LEDs lens for cracks or fractures in the lenses.	Replace LED optical assy if there are cracked or missing individual lenses
	Check for vegetation or other obstruction near REIL assembly.	Use herbicide or manually to remove vegetation.
Monthly	Verify LED flash head alignment.	Realign, repair, or replace as necessary.
	Check local and remote operation by rotating selector switch in primary control cabinet.	If controls malfunction, repair or replace controls as necessary.
	Verify operation of interlocks by opening control cabinet door.	If interlocks malfunction, replace interlocks.
	Check for moisture, dirt, and debris inside control panel.	Clean and wipe dry as necessary.
	Check for signs of insects or rodents inside the control panel.	Clean and treat as necessary.
Semiannually	Verify alignment and leveling of LED REIL is within compliance with local requirements.	Realign and level as necessary.
	Check seals on enclosures.	Replace worn or deteriorated seals.
	Check external electrical connections for loose connections or damaged equipment.	Tighten and repair or replace components as necessary.
	Check external wires for cracks and deterioration.	Repair or replace as necessary.
	Check for rigidity of support structures.	Tighten all mounting hardware as necessary.
Annually	Check performance of power distribution equipment.	Repair or replace as necessary.
	Perform an insulation resistance test on power cable.	If reading is less than 500 V on meter or leaking to ground, replace power cable.

Table 8: LED REIL Preventative Maintenance Schedule

Interval	Maintenance Task	Action
	Perform a resistance test of the grounding system.	With the power feeder neutral disconnected connect a 6 AWG bare solid copper wire at the external ground lug and route wire through the conduit to the ground rod. The ground resistance shall not exceed 25 ohms. Repair as necessary.
	Check paint for scratches, chips or damage.	Touch up or repaint as necessary.

5.1.1 Replacing the LED Light Engine

To remove and replace the LED Light Engine see [Figure 10](#) and then proceed as follows:



Note

Individual LED's can not be replaced.

1. Turn the power off in the control cabinet by placing the On/Off service switch in the OFF position or by disengaging the external circuit breaker. (Opening the door will place the service switch into the OFF position)
2. Remove four (4) #6-32 X 1/2 in pan head phillips screws, four (4) #6-32 hex nuts (65A0015/11), and four (4) #6 split lock washers (66A0026/11) that secure the outer ring to the front of the flash head assembly. Set aside the outer ring and lens. Discard the gasket and clean the seal surface of the flash head.
3. Disconnect the two (2) leads connected to LED boards 1 & 3 of the LED light engine.
4. Remove the access door from the back of the flash head by removing one (1) retaining screw. Set aside door and screw.

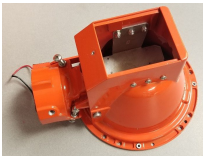

5. Remove four (4) #8-32 X 1/2 in phillips head screws (64A0191/8), four (4) #8-32 nylon insert lock nuts (65A0347/8), and two (2) black nylon hole plugs (63A1091) holding the LED light engine in place and discard.

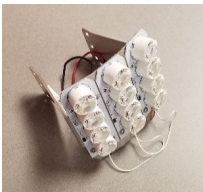

6. Insert the new LED light engine into the flash head ensuring the leads are at the bottom of the LED light engine. Attach using new hardware: four (4) #8-32 X 1/2 in phillips head screws (64A0191/8), four (4) #8-32 nylon insert lock nuts (65A0347/8), and two (2) black nylon hole plugs (63A1091).
7. Disconnect the new leads from the LED light engine, discard, and connect old leads to the LED light engine boards 1 & 3. XXXX Note: If old connectors are damaged, do not disconnect new leads from new LED light engine. Instead tie new leads together with old leads and from inside the control cabinet pull leads through the conduit. Replace old leads connected to the TB2 terminals 1 & 2 with new leads. Reuse EMI reducing ferrite.
8. Reinstall the access door from the back of the flash head and secure using one (1) retaining screw.
9. Install a new gasket with the "top" marking orientated to the top of the head.

10. Clean both surfaces of the lens with a damp cotton cloth and reinstall the lens, and outer ring using new hardware: four (4) #6-32 X 1/2 in pan head phillips screws, four (4) #6-32 hex nuts (65A0015/11), and four (4) #6 split lock washers (66A0026/11).
11. Ensure all screws are tight before closing the control cabinet door and turning on the power.
12. Restore power to return the unit to service.

Figure 10: LED Light Engine Replacement Kit AK00014-000-01

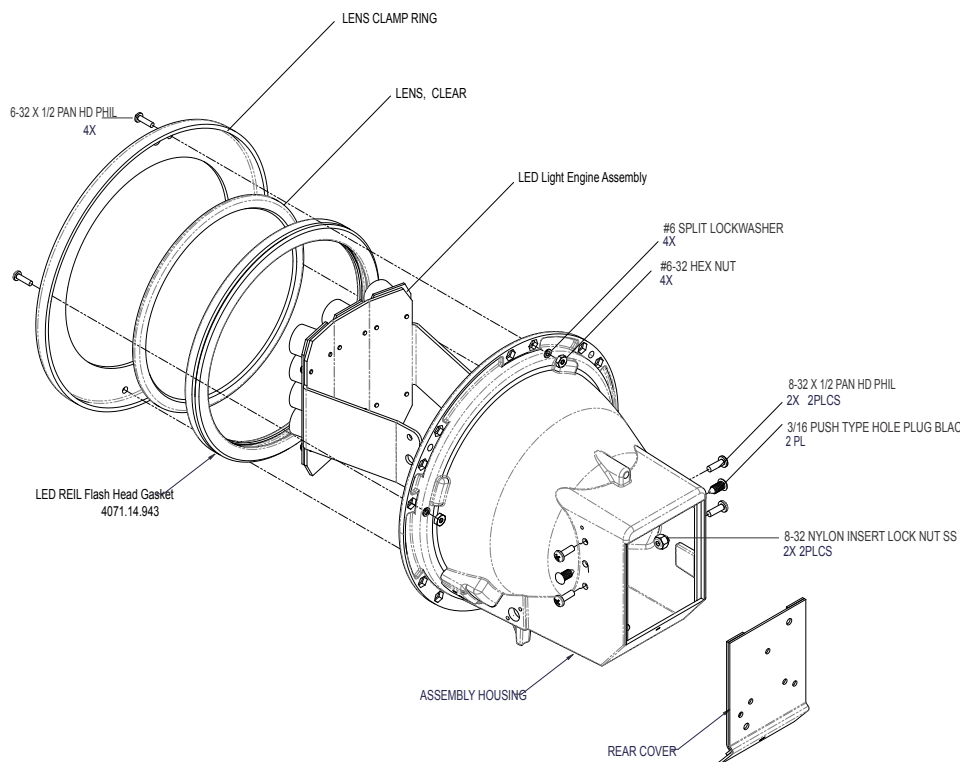

AK00014-000-01 LED Light Engine Replacement Kit includes:

- AS00007-000-01 LED Light Engine Assembly (Qty 1)
- 4071.14.943 Gasket (Qty 1)
- 65A0347/8 8-32 Nylon Insert Lock-Nut (Qty 4)
- 64A0191/8 8-32x1/2 Pan Head (Qty 4)
- 64A0198/8 6-32 X ½ Pan Head Phillips Screw (Qty 4)
- 66A0026/11 #6 Split Lockwasher (Qty 4)
- 65A0015/11 6-32 Hex Nut (Qty 4)
- 63A1091 Black Nylon Hole Plug (Qty 2)

5.2 Replacing the Control PCB



CAUTION

ELECTROSTATIC SENSITIVE DEVICES

This equipment may contain electrostatic sensitive devices.

- Protect from electrostatic discharge.
- Electronic modules and components should be touched only when this is unavoidable e.g. soldering, replacement.
- Before touching any component of the cabinet you should bring your body to the same potential as the cabinet by touching a conductive earthed part of the cabinet.
- Electronic modules or components must not be brought in contact with highly insulating materials such as plastic sheets, synthetic fiber clothing. They must be laid down on conductive surfaces.
- The tip of the soldering iron must be grounded.
- Electronic modules and components must be stored and transported in conductive packing.

Failure to follow this instruction can result in equipment damage.

Figure 11: REIL A-E-C Current Driven Cabinet Interior

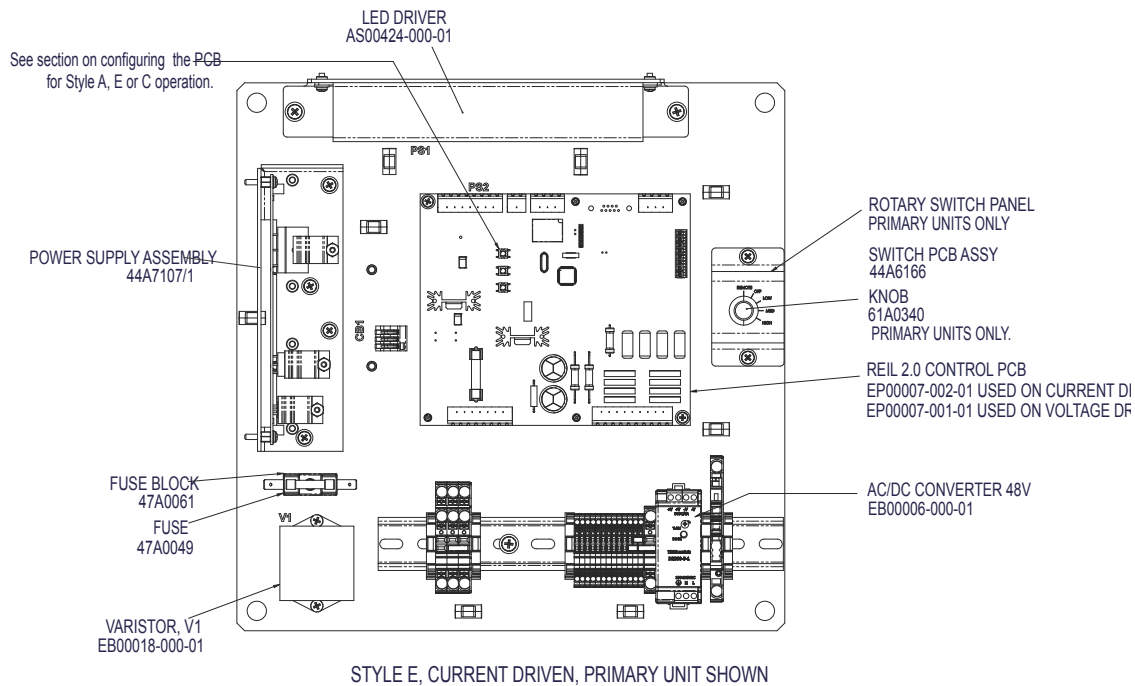
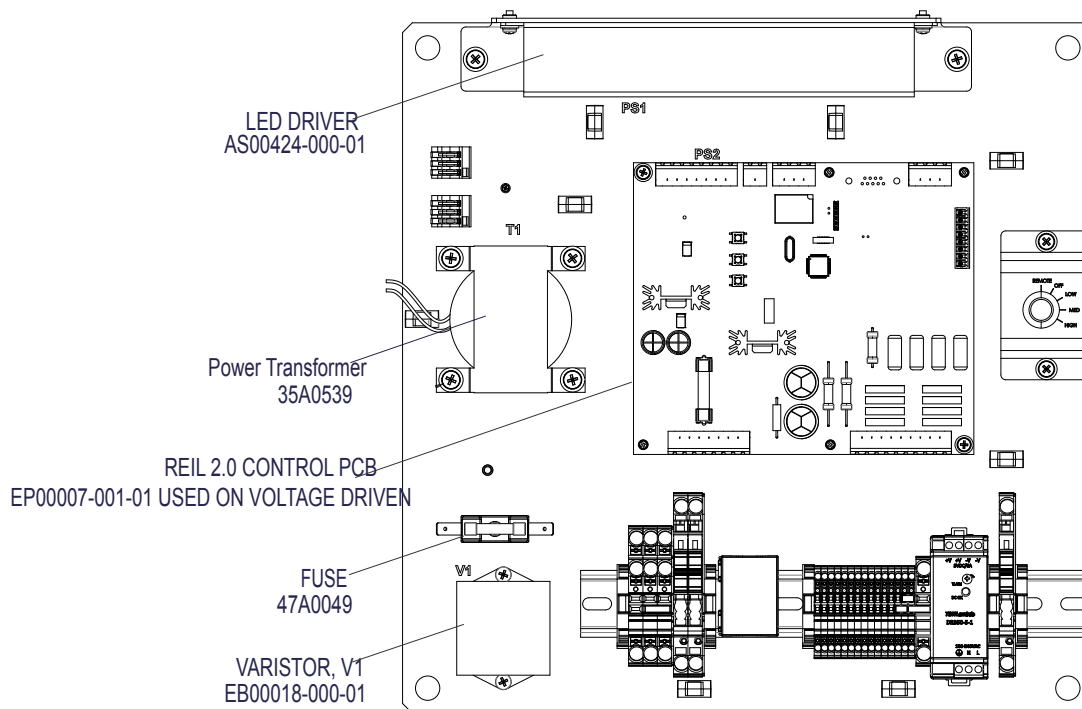

Figure 12: REIL A-E-C Voltage Driven Cabinet Interior



STYLE E, VOLTAGE DRIVEN, PRIMARY UNIT SHOWN

1. Turn off the power to the REIL.
Turn switch (S1) off (on primary units only).
Opening the door will open the door switch contactor. (DO NOT pull the plunger out to close the contact)
2. Disconnect the wire connectors from the PCB.



Note

Use electronic static protection when handling the PCB.

3. Remove the retaining screws for the PCB and then the PCB itself.
4. Replace the PCB and the retaining screws. Do not over tighten.
5. Replace the wire connectors to the PCB.
6. Restore power to the REIL.



Note

You may need to set the PCB configuration. See the current adjust section in the Operation chapter.

6.0 Troubleshooting

This section provides troubleshooting information for the LED REIL Runway End Identification Light system. This information covers only the most common problems that may be encountered. If the problem cannot be resolved by following the procedures presented in this section, contact your local ADB Safegate representative for help.



WARNING

When it is absolutely mandatory that an interlock be bypassed to trace a fault or correct a malfunction, authorized maintenance personnel may perform the bypass by pressing in the activator and turning it clockwise for the specific test to be made. Immediately after completing the test, the interlock shall be restored to working condition.

Failure to observe a warning may result in personal injury, death or equipment damage.

Table 9: LED REIL Troubleshooting Procedures

Problem	Possible Cause	Solution
1. No flashing in either individual control cabinets	No input power	Voltage Driven: Check voltage at terminal block TB1 terminals 14 and 15. Current Driven: Verify input current is present at TB1 terminals 14 and 15.
	Blown fuse F2 or F3 in Primary Cabinet	Replace fuse. Determine why fuse has blown and repair.
	Voltage Driven: External circuit breaker trips each time it is turned on	Lightning arrestor V1 is shorted. Replace lightning arrestor.
	No power to Flasher Control Board.	Fuse F13 blown. Replace F1.
2. One individual control cabinet flashes, but the other one does not	Secondary unit is turned off.	Turn Secondary unit ON
	Blown F1, F2 or F3 fuse in non-flashing unit.	Replace fuse. Determine why fuse has blown and repair.
	LED Optical Assembly defective.	Replace Optical Assembly.
	Current driven REIL- Failed Power Supply.	Verify that 240VDC is present at power supply terminals E5 (+) to E6 (-). Replace power supply if correct voltage is not present.
	Flasher Control PCB failed.	Replace PCB.
3. Light flashes intermittently	Loose external wire connection.	With the power off and using an ohmmeter, check continuity of each wire.
	Isolation transformer is too small.	Confirm and/or replace with the correct size isolation transformer. If the problem persists, confirm calibration of the current monitoring option is in accordance with section CCR Settings and Flash Intensity . If necessary, restore default settings.
	Flasher Control PCB failing.	Replace Flasher Control PCB.
4. Operates in Local control but not In Remote	LED Optical Assembly failing	Replace the assembly.
	Fuse F4 blown. No 48VDC is present for remote control signals.	Replace F4. Determine reason for short in external remote control circuitry.

Figure 14: Primary Current-Driven LED REIL Internal Wiring Diagram (2 of 2)

DA00008-PCD-01 = Primary Current Driven

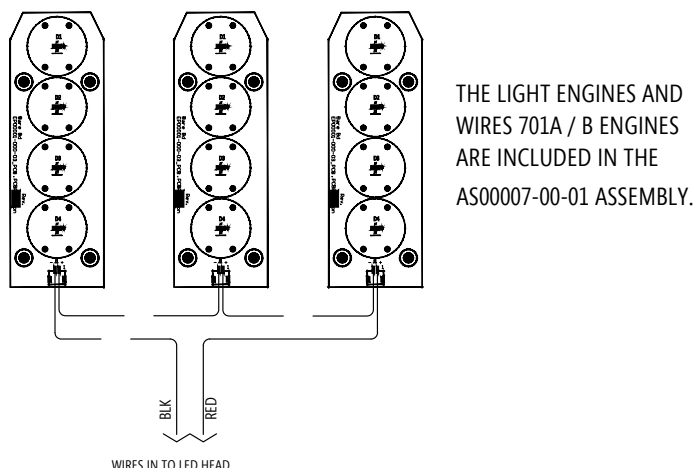

DETAIL "A" (NOTE 7)

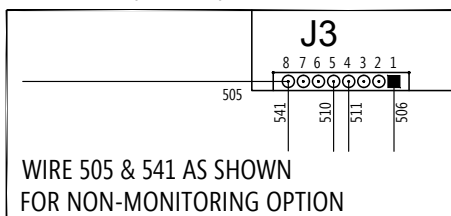

DETAIL "B" (NOTE 3)

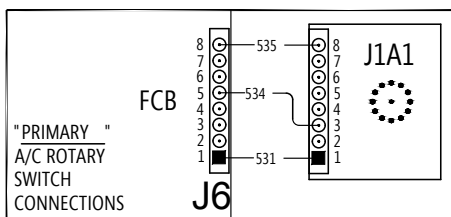

SHEET 1 NOTES:

- 1) ALL PART SUBSTITUTIONS MUST BE APPROVED BY ADB ENGINEERING.
- 2) ALL JUNCTIONS MARKED WITH ARE WIRES JOINED OR CAPPED OFF WITH INSULATED CRIMP-ON WIRE SPLICE. DOOR GND WIRE (915) IS PROVIDED WITH WIRE KIT BUT IS NOT SHOWN.
- 3) WIRING OF J6 CHANGES FOR SECONDARY(SLAVE) UNIT. SEE SHEET 2. ROTARY SWITCH CONNECTIONS FOR "A/C" STYLE SHOWN IN DETAIL "B"
- 4) CONNECT INPUT GROUND FOR AS00424-000-01 TO THE ADJACENT MOUNTING STUD FOR THE COMPONENT PANEL. USE 70A0289 RING TERMINAL.
- 5) USE SUPPLIED JUMPERS TO CONNECT TERMINALS AS SHOWN
- 6) PLACE CLAMP ON FERRITE ON WIRES WHERE INDICATED. PASS EACH WIRE THROUGH ONE LOOP IN FERRITE. "FBA" = EL00001 (FAIR-RITE 250R EQUIVALENT)
"FBB" = EI00002 (FAIR-RITE 550R EQUIVALENT)
- 7) WIRING OF J3 CHANGES WHEN NON-MONITORING OPTION IS USED. SEE DETAIL "A".
- 8) ALL JUNCTIONS MARKED WITH ARE WIRES JOINED BY 70A0671 CLAMP-ON WIRE SPLICES.

WIRE SPECS:

- | | |
|--|---------------------------------|
| 500 SERIES = 18AWG, 600V, 105C, WHITE | 701A = 20AWG, 600V, 105C, RED |
| 900 SERIES = 18AWG, 600V, 105C, GREEN/YELLOW | 701B = 20AWG, 600V, 105C, BLACK |

DRAWING NUMBER	SHEET NUMBER
DA00008-XXX-01	1 OF 6
	REV
	J

Figure 16: Secondary Current-Driven LED REIL Internal Wiring Diagram (2 of 2)

DA00008-SCD-01 = Secondary Current Driven

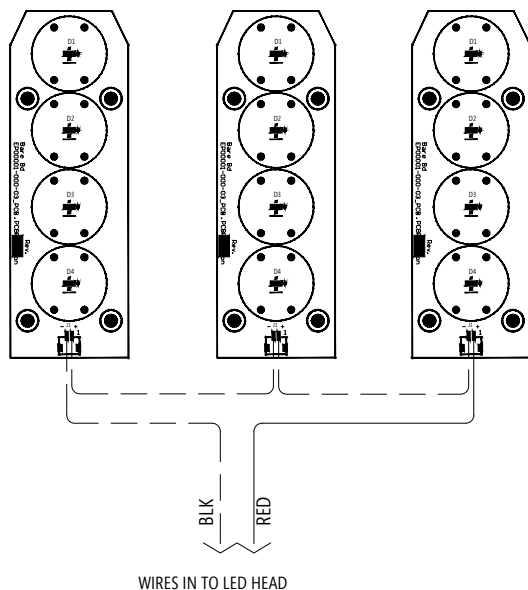

THE LIGHT ENGINES AND WIRES 701A / B ENGINES ARE INCLUDED IN THE AS00007-00-01 ASSEMBLY.

SHEET 2 NOTES:

- 1) ALL PART SUBSTITUTIONS MUST BE APPROVED BY ADB ENGINEERING.
- 2) ALL JUNCTIONS MARKED WITH ARE WIRES JOINED OR CAPPED OFF WITH INSULATED CRIMP-ON WIRE SPLICE. DOOR GND WIRE (915) IS PROVIDED WITH WIRE KIT BUT IS NOT SHOWN.
- 3) WIRING OF J6 CHANGES FOR PRIMARY (MASTER) UNIT.
- 4) CONNECT INPUT GROUND FOR AS00424-000-01 TO THE ADJACENT MOUNTING STUD FOR THE COMPONENT PANEL. USE 70A0289 RING TERMINAL.
- 5) J6 JUMPERS ARE 18AWG, 600V, 105C, WHITE AND SHOULD COME POPULATED IN MATING PLUG FOR CONNECTOR WITH EW00026-SCD-01 WIRE HARNESS
- 6) PLACE CLAMP ON FERRITE ON WIRES WHERE INDICATED. PASS EACH WIRE THROUGH ONE LOOP IN FERRITE. "FBA" = EL00001 (FAIR-RITE **0443167251** OR EQUIVALENT)
"FBB" = EL00002 (FAIR-RITE **0431173551** OR EQUIVALENT)
- 7) ALL JUNCTIONS MARKED WITH ARE WIRES JOINED BY 70A0671 CLAMP-ON WIRE SPLICES.

WIRE SPECS:

- 500 SERIES = 18AWG, 600V, 105C, WHITE
- 900 SERIES = 18AWG, 600V, 105C, GREEN/YELLOW
- 701A = 20AWG, 600V, 105C, RED
- 701B = 20AWG, 600V, 105C, BLACK

	SHEET NUMBER:
	2 OF 6
DRAWING NUMBER:	REV.
DA00008-XXX-01	J

Figure 17: Current-Driven LED REIL External Wiring Diagram

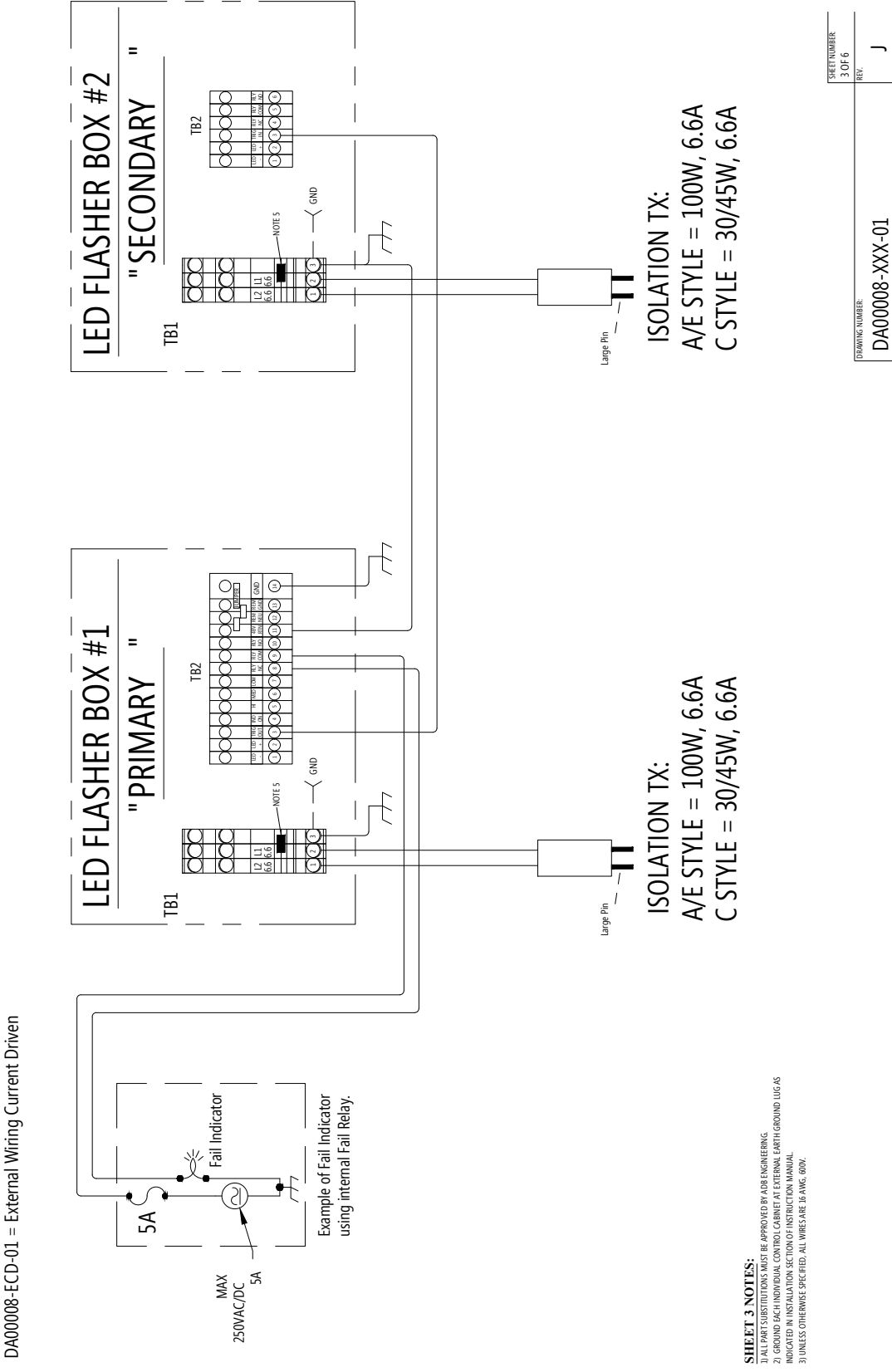

SHEET 3 NOTES:
 1) ALL PART SUBSTITUTIONS MUST BE APPROVED BY ADB ENGINEERING.
 2) GROUND EACH INDIVIDUAL CONTROL CABINET AT EXTERNAL EARTH GROUND LUG AS INDICATED IN INSTALLATION SECTION OF INSTRUCTION MANUAL.
 3) UNLESS OTHERWISE SPECIFIED, ALL WIRES ARE 16 AWG, 600V.

SHEET NUMBER:	J
3 OF 6	
DRAWING NUMBER:	DA000008-XXX-01
REV.	

Figure 19: Primary Voltage-Driven LED REIL Internal Wiring Diagram (2 of 2)

DA00008-PVD-01 = Primary Voltage Driven

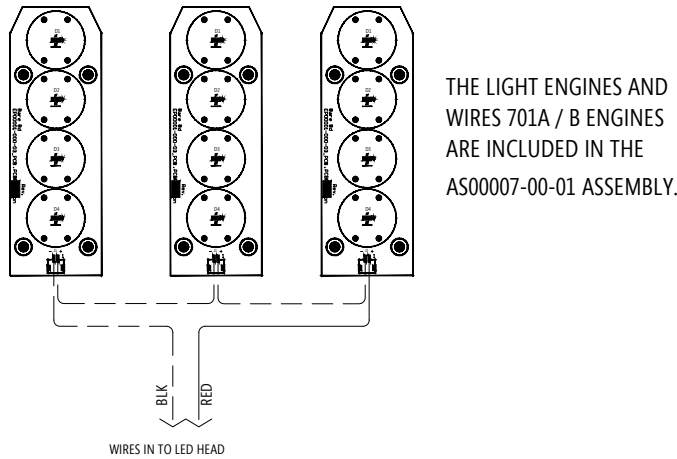

DETAIL "D" (NOTE 7)

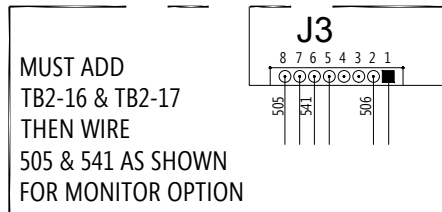

DETAIL "E" (NOTE 3)

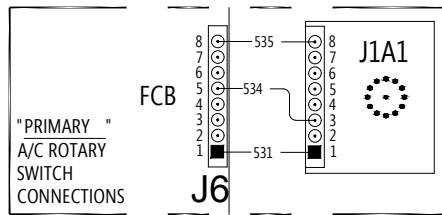

SHEET 4 NOTES:

- 1) ALL PART SUBSTITUTIONS MUST BE APPROVED BY ADB ENGINEERING.
- 2) ALL JUNCTIONS MARKED WITH ARE WIRES JOINED OR CAPPED OFF WITH INSULATED CRIMP-ON WIRE SPLICE. DOOR GND WIRE (915) IS PROVIDED WITH WIRE KIT BUT IS NOT SHOWN.
- 3) WIRING OF J6 CHANGES FOR SECONDARY(SLAVE) UNIT. SEE SHEET 5. ROTARY SWITCH CONNECTIONS FOR "A/C" STYLE SHOWN IN DETAIL "E"
- 4) CONNECT INPUT GROUND FOR AS00424-000-01 TO THE ADJACENT MOUNTING STUD FOR THE COMPONENT PANEL. USE 70A0289 RING TERMINAL.
- 5) USE SUPPLIED JUMPERS TO CONNECT TERMINALS AS SHOWN
- 6) PLACE CLAMP ON FERRITE ON WIRES AS SHOWN. UNLESS OTHERWISE NOTED PASS EACH WIRE THROUGH ONE LOOP IN FERRITE. "FBA" = EL00001 (FAIR-RITE 0443167251 OR EQUIVALENT)
 "FBB" = EL00002 (FAIR-RITE 0431173551 OR EQUIVALENT)
- 7) WIRING OF J3 CHANGES WHEN MONITORING OPTION IS USED. SEE DETAIL "D". MUST ADD 2 ADDITIONAL TERMINAL BLOCKS FOR EXTERNAL CONNECTIONS.
- 8) ALL JUNCTIONS MARKED WITH ARE WIRES JOINED BY 70A0671 CLAMP-ON WIRE SPLICES.

WIRE SPECS:
 500 SERIES = 18AWG, 600V, 105C, WHITE
 701A = 20AWG, 600V, 105C, RED
 900 SERIES = 18AWG, 600V, 105C, GREEN/YELLOW
 701B = 20AWG, 600V, 105C, BLACK

DRAWING NUMBER: DA00008-XXX-01	SHEET NUMBER: 4 OF 6 REV. J
--	---

Figure 21: Secondary Voltage-Driven LED REIL Internal Wiring Diagram (2 of 2)

DA00008-SVD-01 = Secondary Voltage Driven

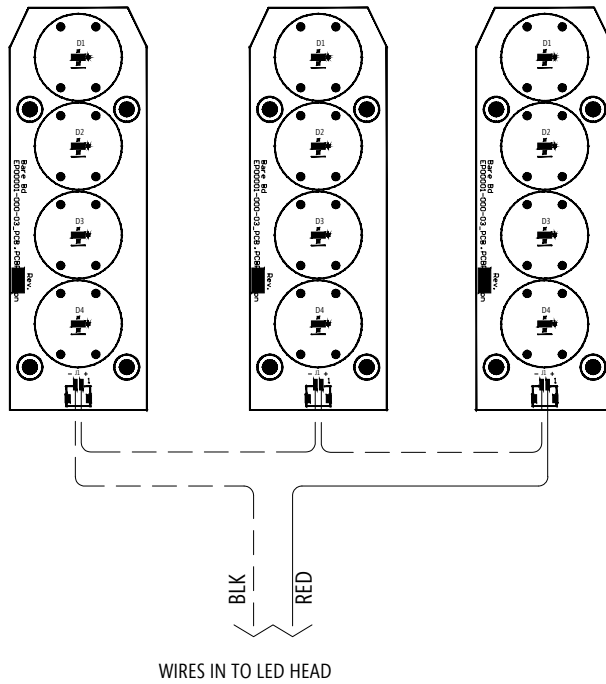

THE LIGHT ENGINES AND WIRES 701A / B ENGINES ARE INCLUDED IN THE AS00007-00-01 ASSEMBLY.

SHEET 5 NOTES:

- 1) ALL PART SUBSTITUTIONS MUST BE APPROVED BY ADB ENGINEERING.
- 2) ALL JUNCTIONS MARKED WITH ARE WIRES JOINED OR CAPPED OFF WITH INSULATED CRIMP-ON WIRE SPLICE. DOOR GND WIRE (915) IS PROVIDED WITH WIRE KIT BUT IS NOT SHOWN.
- 3) WIRING OF J6 CHANGES FOR PRIMARY (MASTER) UNIT.
- 4) CONNECT INPUT GROUND FOR AS00424-000-01 TO THE ADJACENT MOUNTING STUD FOR THE COMPONENT PANEL. USE 70A0289 RING TERMINAL.
- 5) J6 JUMPERS ARE 18AWG, 600V, 105C, WHITE AND SHOULD COME POPULATED IN MATING PLUG FOR CONNECTOR WITH EW00026-SVD-01 WIRE HARNESS
- 6) PLACE CLAMP ON FERRITE ON WIRES AS SHOWN. UNLESS OTHERWISE NOTED PASS EACH WIRE THROUGH ONE LOOP IN FERRITE. "FBA" = EL00001 (FAIR-RITE **0443167251** OR EQUIVALENT)
 "FBB" = EL00002 (FAIR-RITE **0431173551** OR EQUIVALENT)
- 7) ALL JUNCTIONS MARKED WITH ARE WIRES JOINED BY 70A0671 CLAMP-ON WIRE SPLICES.

WIRE SPECS:

- 500 SERIES = 18AWG, 600V, 105C, WHITE
- 900 SERIES = 18AWG, 600V, 105C, GREEN/YELLOW
- 701A = 20AWG, 600V, 105C, RED
- 701B = 20AWG, 600V, 105C, BLACK

DRAWING NUMBER:
DA00008-XXX-01

SHEET NUMBER:
5 OF 6
 REV.
J

Figure 22: Voltage-Driven LED REIL External Wiring Diagram

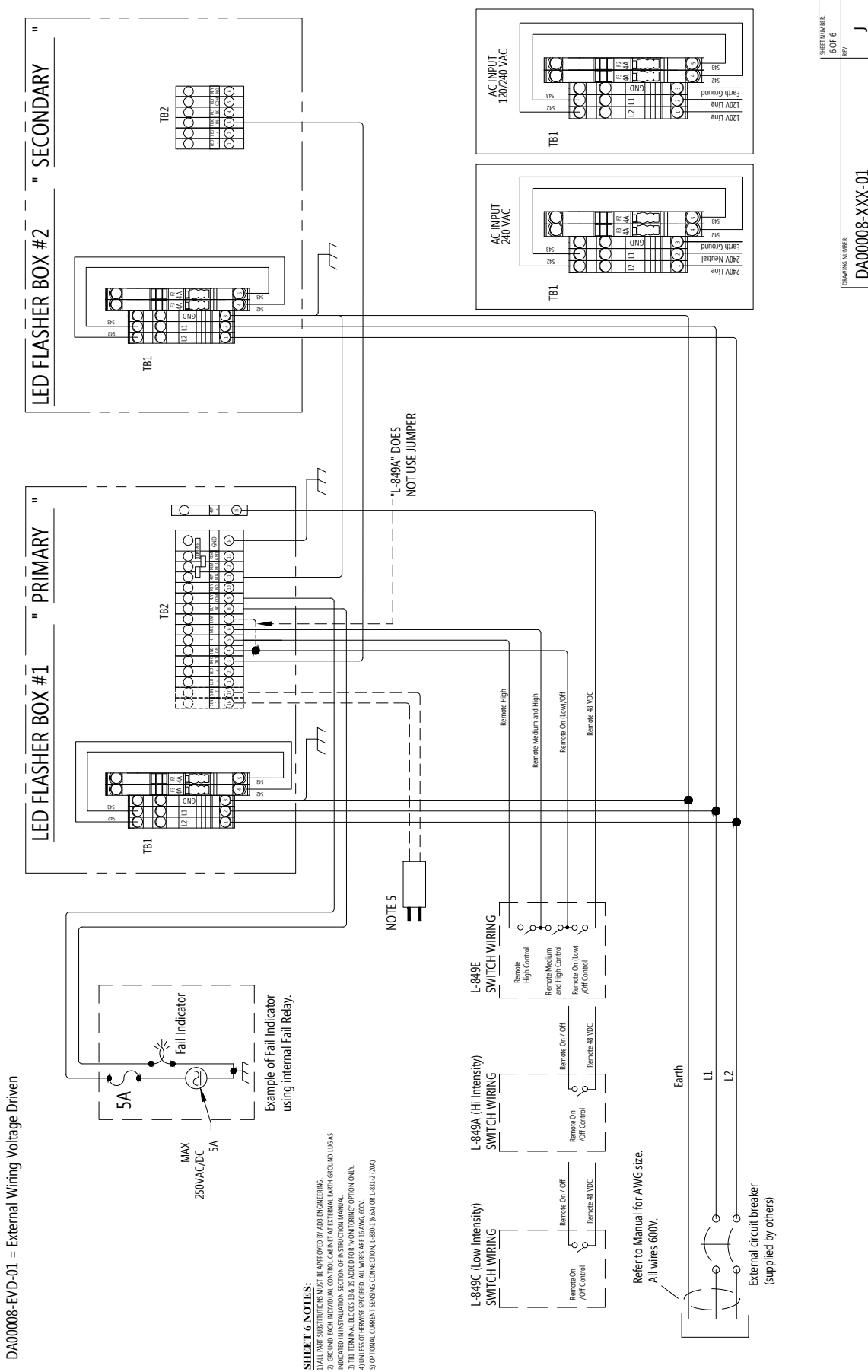

Figure 23: REIL Typical Installation Details

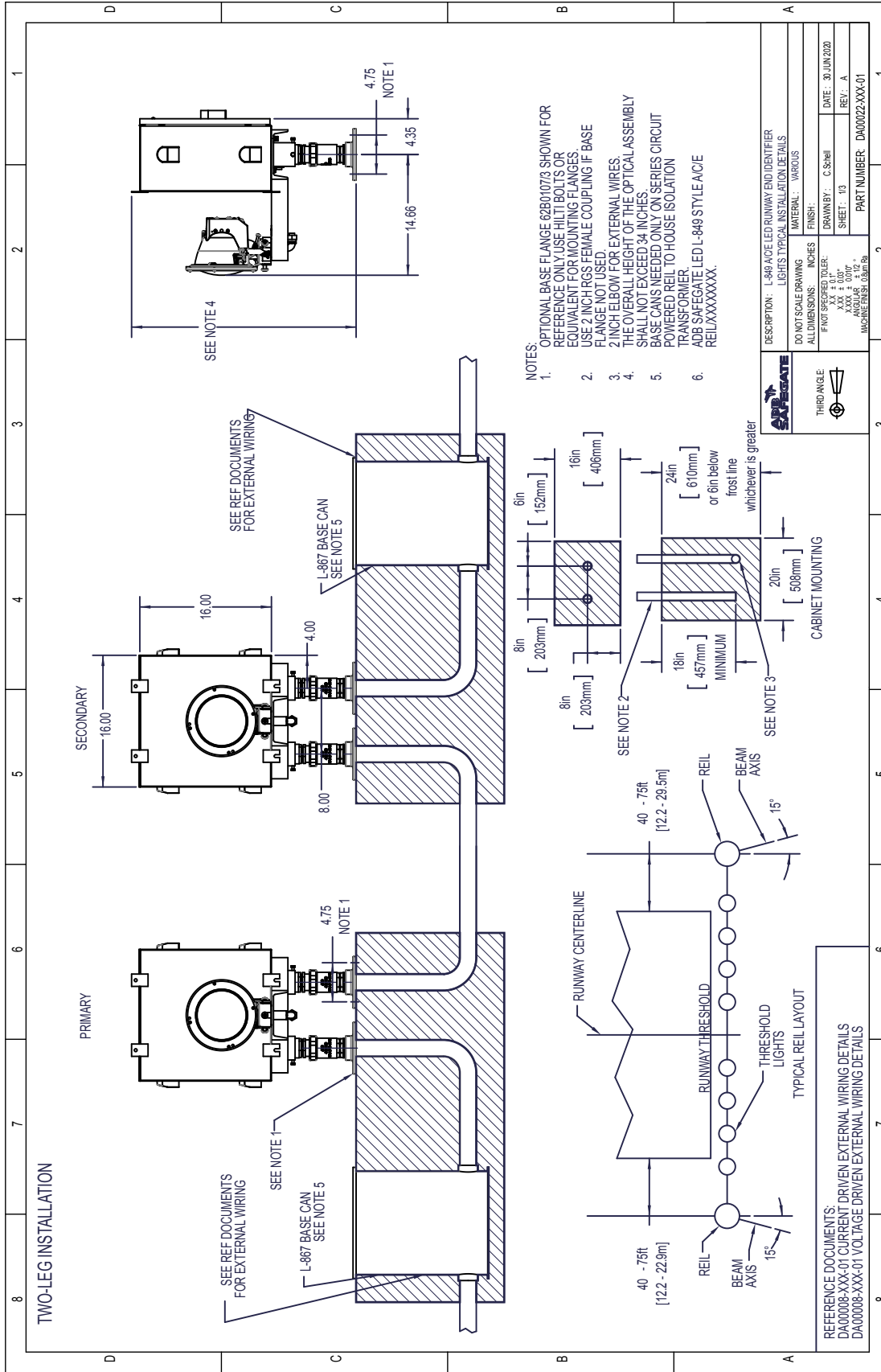

Figure 24: REIL Typical Installation Details

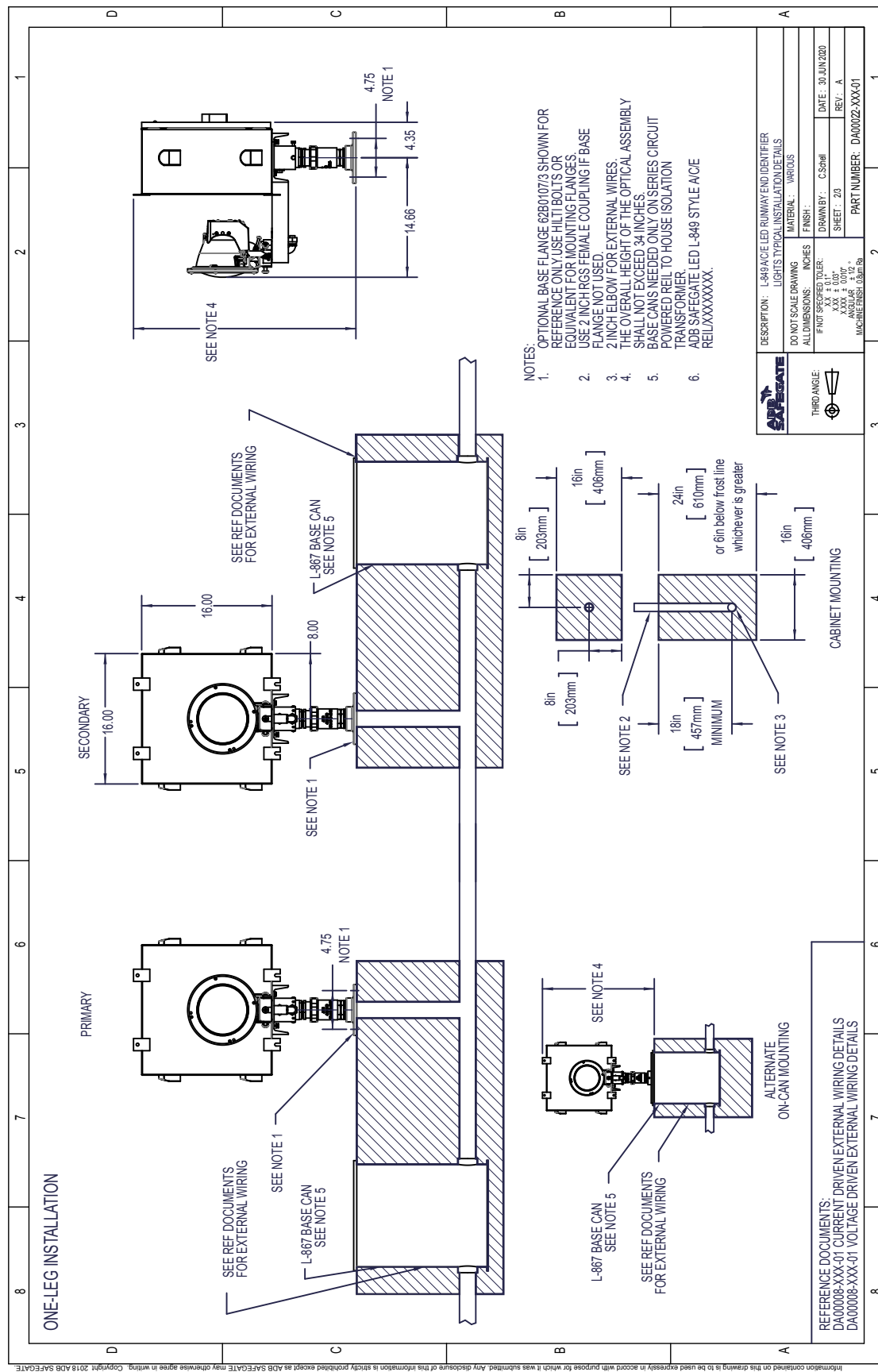
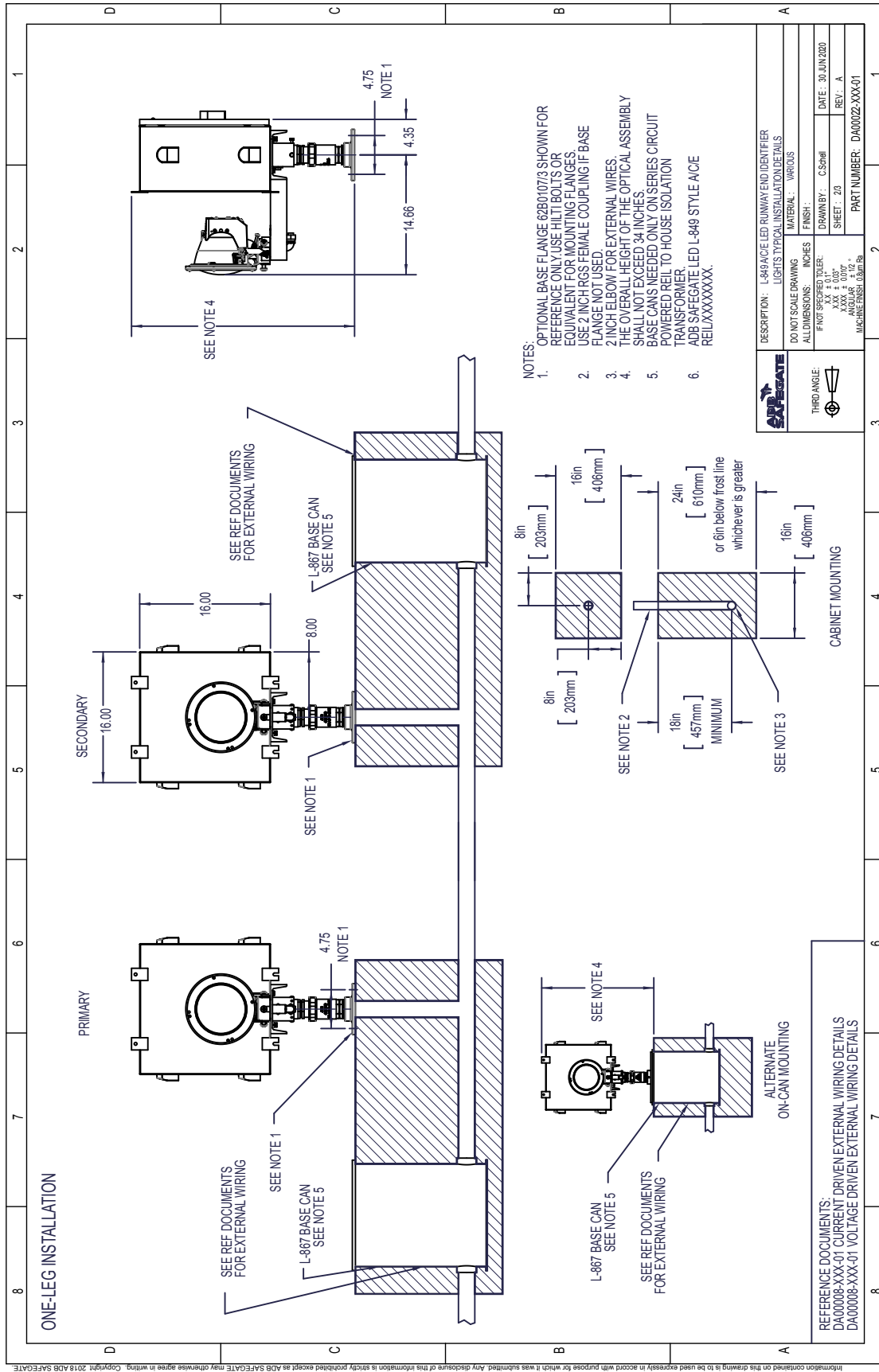

Figure 25: REIL Remote Mount Installation Details



7.0 LED REIL Parts

To order parts, call ADB Safegate Customer Service or your local representative. Use the parts lists, and the accompanying illustration, to describe and locate parts correctly.

Ordering Code

REIL / X X X X 0 X 2

Style

- A = High-intensity, one brightness step
- C = Low-intensity, one brightness step
- E = Three brightness steps

Power

- 1 = Current-powered¹
- 2 = Voltage-powered

Current Sensing Option²

- 0 = Without current sensing
- 1 = With current sensing

Flash Head Mounting

- 0 = Mounted with enclosure (as shown above)
- 1 = Separate remote mounting on a 2-inch EMT³

Enclosure Mounting

- 1 = One-leg mounting
- 2 = Two-leg mounting

0

Enclosure Type

- 1 = Steel (Painted Aviation Orange)
- 2 = Stainless Steel (Not ETL Certified)

2

Notes

- ¹ A current-powered REIL (powered by a CCR) always has current sensing and cannot be ordered without the current sensing option.
- ² The current sensing option provides ON/OFF control (Style A/C) or 3-step intensity control (Style E) of the REIL system depending on the current level in the series lighting circuit. The current-powered LED REIL doesn't require a separate isolation transformer. The input current from the isolation transformer that powers the primary cabinet is also used for current sensing control. The current sensing input of a voltage-powered LED REIL can be connected to 6.6 A or 20 A series with a 30/45 W isolation transformer 6.6/6.6 A (35C0077) or 20/6.6 A (35C0078). Use 16 AWG 600 V shielded cable supplied by contractor.
- ³ EMT and flash head cabling to be supplied by contractor. Use 16 AWG 600 V shielded cable. Cable length may be up to 100 ft (30.5 m) maximum.

7.1 Major Components

Figure 26: Side View

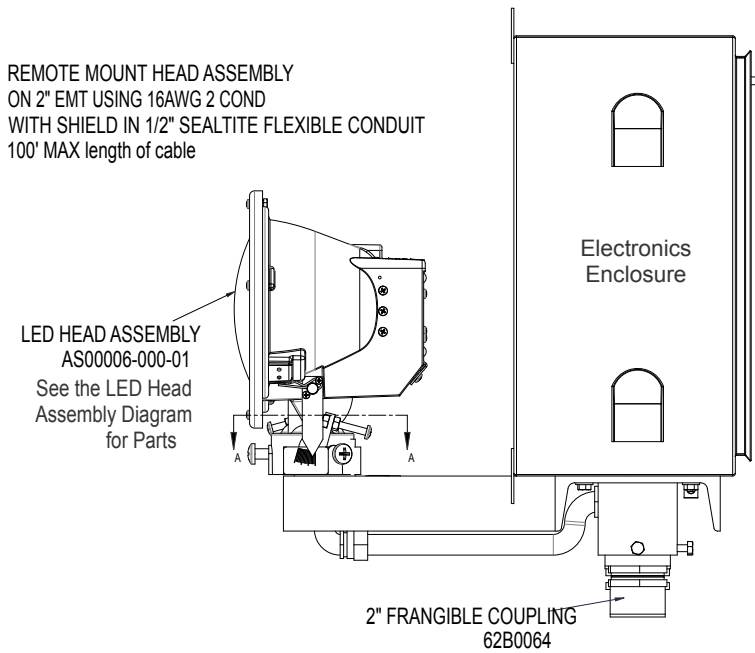

Note

The same control panel is used in each individual control cabinet.

Figure 27: Enclosure Assembly Front View

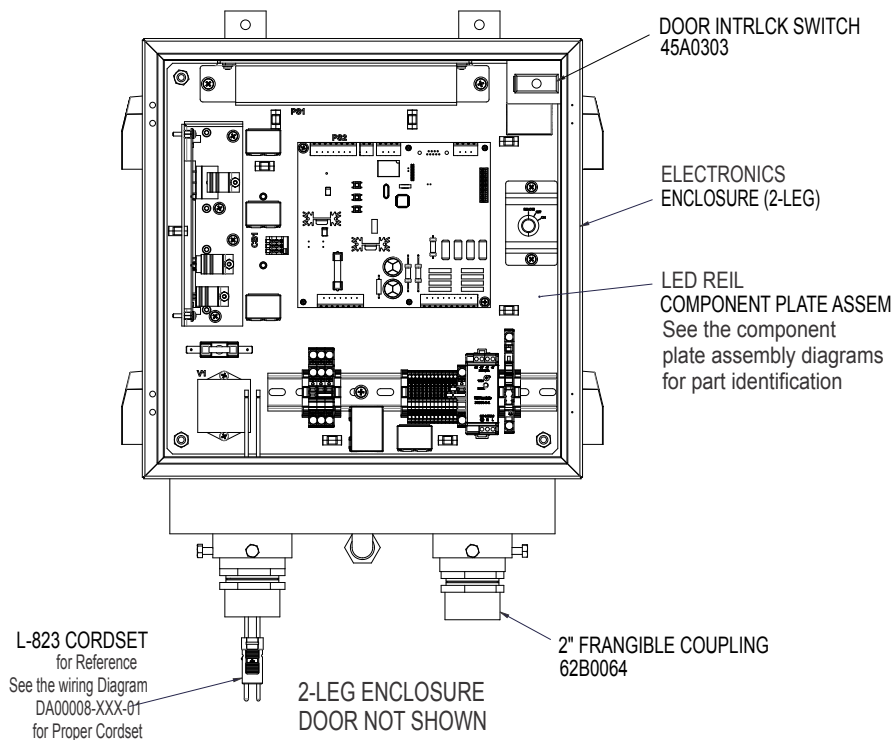
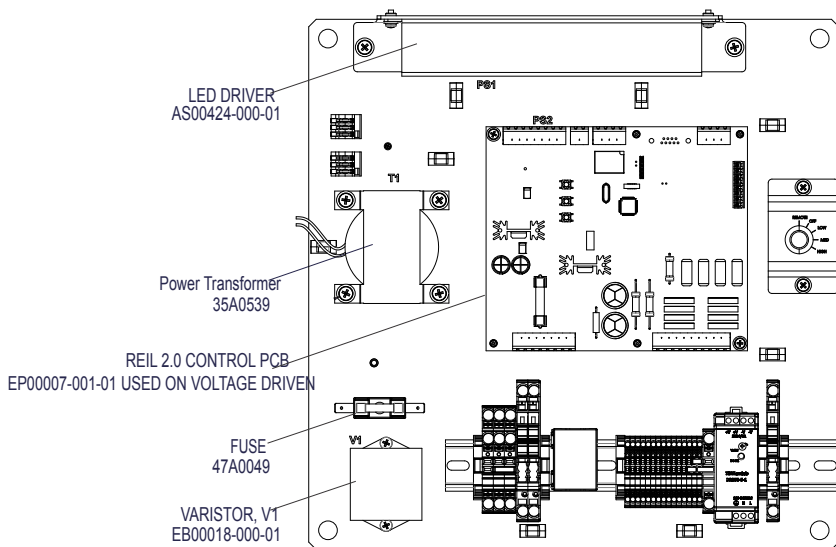
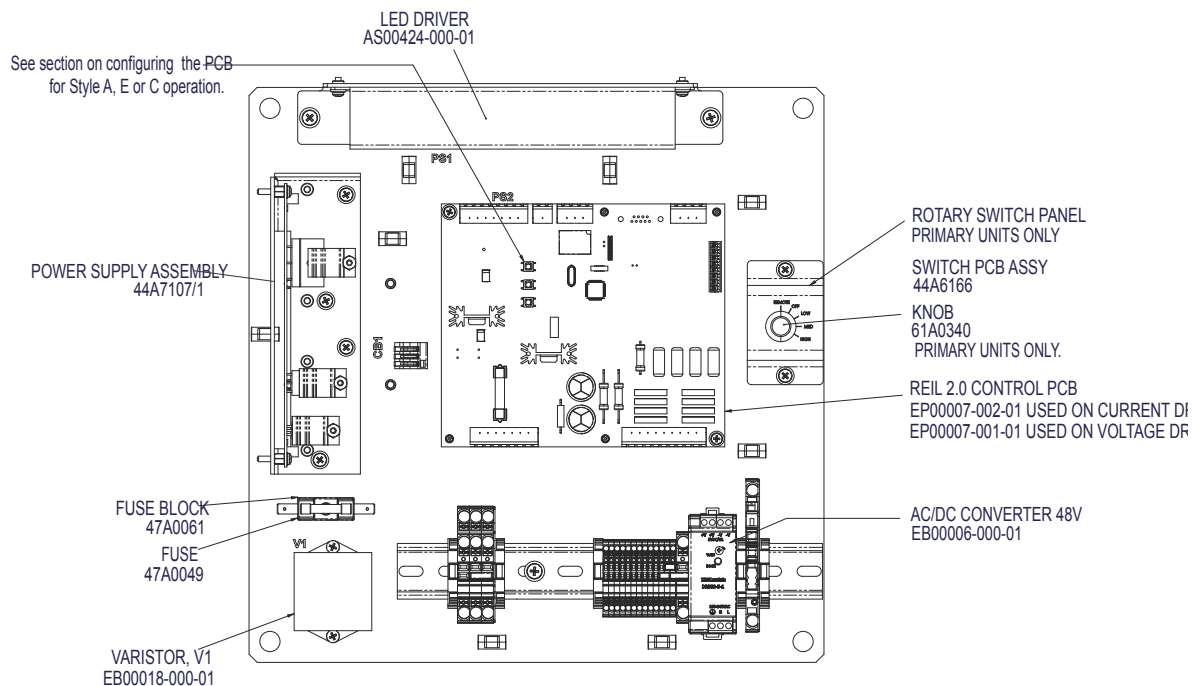

Figure 28: Component Panel Parts (Voltage Driven)



STYLE E, VOLTAGE DRIVEN, PRIMARY UNIT SHOWN

Figure 29: Component Panel Parts (Current Driven)



STYLE E, CURRENT DRIVEN, PRIMARY UNIT SHOWN

Figure 30: LED Engine Replacement Kit AK00014-000-01

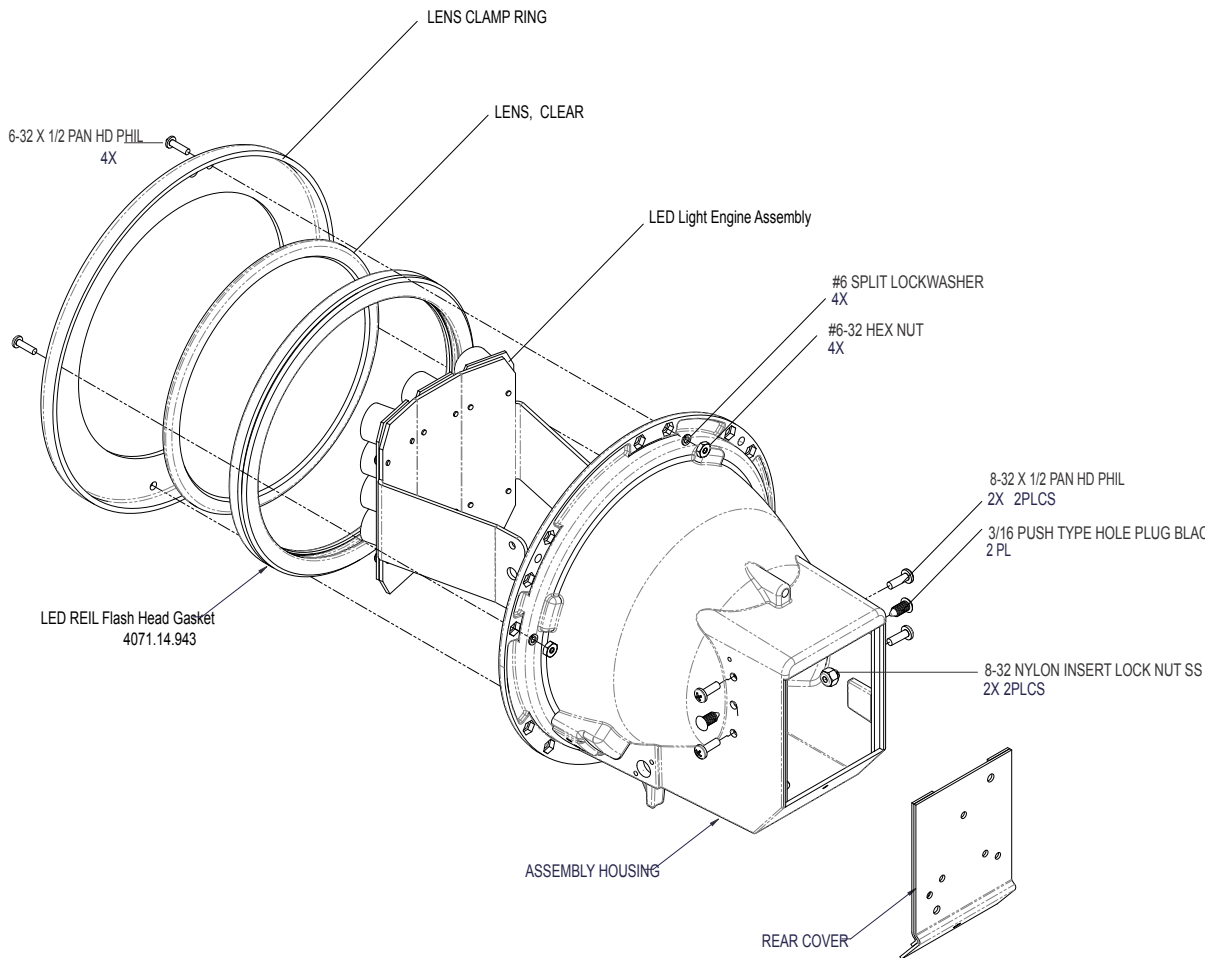

7.2 Spare Parts

Table 10: Spare Parts

Part number	Description	Note
EP00007-001-01	Control PCB Voltage	Voltage Powered Units Only see Figure 28
EP00007-002-01	Control PCB Current	Current Powered Units Only see Figure 28
35A0539	Power Transformer, T1	Voltage Only see Figure 28
AS00424-000-01	LED Driver	All REIL Cabinets see Figure 29 or Figure 28
EB00006-000-01	AC/DC Converter 48V	Primary Only see Figure 29 or Figure 28
EB00018-000-01	Varistor, V1	Figure 29 or Figure 28
61A0340	Knob	Primary Only see Figure 29 or Figure 28
44A6166	Switch PCB Assembly	Primary Only see Figure 29 or Figure 28
45A0303	Door Interlock Switch	Figure 28
44A7107/1	Power Supply Assembly	Current Only see Figure 29

Table 10: Spare Parts

Part number	Description	Note
47A0049	Fuse 2A Slow Blow, F1	Figure 29 or Figure 28
AS00006-000-01	LED Head Assembly	Figure 26
AK00014-000-01	LED Engine Replacement Kit includes: <ul style="list-style-type: none"> ▪ AS00007-000-01 Optical Assembly (Qty 1) ▪ 4071.14.943 Gasket (Qty 1) ▪ 65A0347/8 8-32 Nut with nylon insert (Qty 4) ▪ 64A0191/8 8-32x1/2 Pan Head (Qty 4) ▪ 64A0198/8 6-32 X ½ Pan Head Phillips Screw (Qty 4) ▪ 66A0026/11 #6 Split Lockwasher (Qty 4) ▪ 65A0015/11 6-32 Hex Nut (Qty 4) ▪ 63A1091 Black Nylon Hole Plug (Qty 2) 	Figure 30
64A0290	Hitch Pin	Figure 30
64A0289-64	Clevis Pin	Figure 30
60A4655/1	Lens Clamp Ring	Figure 30
63A0958-0	Lens, Clear	Figure 30
4071.14.943	LED REIL Flash Head Gasket	Figure 30
60B0943	Indicator Pointer Plate	Figure 30

Appendix A: Support

Our experienced engineers are available for support and service at all times, 24 hour/7 days a week. They are part of a dynamic organization making sure the entire ADB SAFEGATE is committed to minimal disturbance for airport operations.

ADB SAFEGATE Support

Technical Support – Global

Customers in Europe, the Middle East, Africa and Asia Pacific are more than welcome to our portal for technical support. Trained in all areas of system issues, troubleshooting, quality control and technical assistance, our highly experienced Technical support specialists are available 24 hours a day, seven days a week to provide assistance over the phone.

Europe: **+32-2-722-17-11**

China: **+86-10-8476-0106**

Middle East and Africa: **+971-4-452-7575**

In the Americas, we also offer live technical support.

Live Technical Support – Americas

If at any time you have a question or concern about your product, contact ADB SAFEGATE's US-based technical support specialists, available 24 hours a day, seven days a week, to assist you via phone.

ADB SAFEGATE Americas Technical Service & Support (US & Canada) :**+1-800-545-4157**

ADB SAFEGATE Americas Technical Service & Support (Canada): **+1-905-631-1597**

ADB SAFEGATE Americas Technical Service & Support (International): **+1-614-861-1304**. For technical service press 3 and for sales support press 4.

We can also be reached via email during regular business hours.

Airfield and Gate: **techservice.us@adbsafegate.com**

Gate: **gateservice.us@adbsafegate.com**

We look forward to working with you!

Before You Call

When you have an airfield lighting or control system problem, prior to calling, please ensure the following:

- Review the product's manual and troubleshooting guide.
- Be located with the product ready to troubleshoot.
- Have all necessary information available: airport code/company name, customer id number, contact phone number/email address, product/part number.
- Have all necessary tools that may be needed at hand.

When calling about an issue with Safedock A-VDGS, we can serve you better if you collect the following information before you call:

- Relevant information regarding the issue you are calling about, such as gate number, flight number, aircraft type and time of the event.
- What, if any, actions have been taken to resolve the issue prior to the call.
- If available, provide a CCTV recording of the incident to aid in aligning the information from the Safedock log file.

For more information, see www.adbsafegate.com, contact ADB SAFEGATE Support via email at **support@adbsafegate.com**.

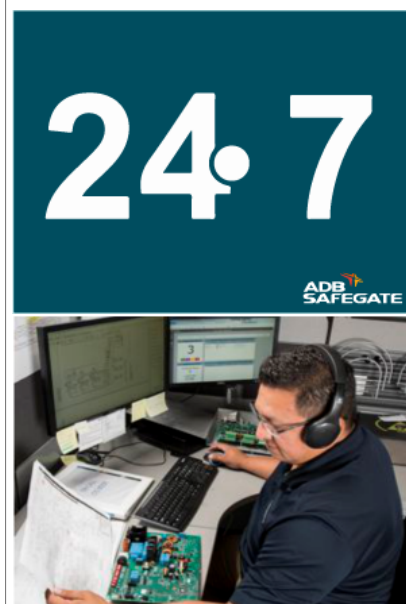

A.1 ADB SAFEGATE Website

The ADB SAFEGATE website, www.adbsafegate.com, offers information regarding our airport solutions, products, company, news, links, downloads, references, contacts and more.

A.2 Recycling

A.2.1 Local Authority Recycling

The disposal of ADB SAFEGATE products is to be made at an applicable collection point for the recycling of electrical and electronic equipment. The correct disposal of equipment prevents any potential negative consequences for the environment and human health, which could otherwise be caused by inappropriate waste handling. The recycling of materials helps to conserve natural resources. For more detailed information about recycling of products, contact your local authority city office.

A.2.2 ADB SAFEGATE Recycling

ADB SAFEGATE is fully committed to environmentally-conscious manufacturing with strict monitoring of our own processes as well as supplier components and sub-contractor operations. ADB SAFEGATE offers a recycling program for our products to all customers worldwide, whether or not the products were sold within the European Union (EU).

ADB SAFEGATE products and/or specific electrical and electronic component parts which are fully removed/separated from any customer equipment and returned will be accepted for our recycling program.

All items returned must be clearly labeled as follows:

- For Restriction of Hazardous Substances (*RoHS*)/Waste Electrical and Electronic Equipment (*WEEE*) Recycling
- Sender contact information (Name, Business Address, Phone number).
- Main Unit Serial Number.

ADB SAFEGATE will continue to monitor and update according for any future requirements for *EU directives* as and when *EU member states* implement new *regulations* and or *amendments*. It is our aim to maintain our *compliance plan* and assist our customers.

Company Addresses

ADB SAFEGATE, Belgium	ADB SAFEGATE BV Leuvensesteenweg 585 B-1930 Zaventem Belgium
Contact:	
Tel.: +32 2 722 17 11	Email: marketing@adbsafegate.com
Fax: +32 2 722 17 64	Internet: www.adbsafegate.com
ADB SAFEGATE, Americas	ADB SAFEGATE Americas, LLC 700 Science Blvd Gahanna, OH 43230 USA
Contact:	
Tel.: +1 (614) 861 1304	Email: sales.us@adbsafegate.com
Fax: +1 (614) 864 2069	Internet: www.adbsafegate.com
ADB SAFEGATE, Sweden	ADB SAFEGATE Sweden AB Djurhagegatan 19 SE-213 76 Malmö Sweden
Contact:	
Tel.: +46 (0)40 699 17 00	Email: marketing@adbsafegate.com
Fax: +46 (0)40 699 17 30	Internet: www.adbsafegate.com
ADB SAFEGATE, China	ADB SAFEGATE Airfield Technologies Ltd. China Unit 603, D Block, CAMIC International Convention Center, No 3, Hua Jia Di East road, ChaoYang district, Beijing 100102 P.R. China
Contact:	
Tel.: +86 (10) 8476 0106	Email: china@safegate.com
Fax: +86 (10) 8476 0090	Internet: www.adbsafegate.com
ADB SAFEGATE, Germany	ADB SAFEGATE Germany GmbH Konrad-Zuse-Ring 6, D-68163 Mannheim Germany
Contact:	
Tel.: +49 (621) 87 55 76-0	Email: marketing@adbsafegate.com
Fax: +49 (621) 87 55 76-55	Internet: www.adbsafegate.com

WWW.ADBSAFEGATE.COM

Empowering the Airside **Evolution**

SMARTER. BETTER. **NOW.**

