



ERGL-L

Spare Parts List

SP-2087, Rev. 2.0.1, 2026-Jun-06



A.0 Disclaimer / Standard Warranty

CE certification

The equipment listed as CE certified means that the product complies with the essential requirements concerning safety and hygiene. The European directives that have been taken into consideration in the design are available on written request to ADB SAFEGATE.

ETL certification

The equipment listed as ETL certified means that the product complies with the essential requirements concerning safety and C22.2 No.180:13 (R2018) regulations. The CSA directives that have been taken into consideration in the design are available on written request to ADB SAFEGATE.

All Products Guarantee

ADB SAFEGATE will correct by repair or replacement per the applicable guarantee below, at its option, equipment or parts which fail because of mechanical, electrical or physical defects, provided that the goods have been properly handled and stored prior to installation, properly installed and properly operated after installation, and provided further that Buyer gives ADB SAFEGATE written notice of such defects after delivery of the goods to Buyer. Refer to the Safety section for more information on Material Handling Precautions and Storage precautions that must be followed.

ADB SAFEGATE reserves the right to examine goods upon which a claim is made. Said goods must be presented in the same condition as when the defect therein was discovered. ADB SAFEGATE further reserves the right to require the return of such goods to establish any claim.

ADB SAFEGATE's obligation under this guarantee is limited to making repair or replacement within a reasonable time after receipt of such written notice and does not include any other costs such as the cost of removal of defective part, installation of repaired product, labor or consequential damages of any kind, the exclusive remedy being to require such new parts to be furnished.

ADB SAFEGATE's liability under no circumstances will exceed the contract price of goods claimed to be defective. Any returns under this guarantee are to be on a transportation charges prepaid basis. For products not manufactured by, but sold by ADB SAFEGATE, warranty is limited to that extended by the original manufacturer. This is ADB SAFEGATE's sole guarantee and warranty with respect to the goods; there are no express warranties or warranties of fitness for any particular purpose or any implied warranties of fitness for any particular purpose or any implied warranties other than those made expressly herein. All such warranties being expressly disclaimed.

Standard Products Guarantee

Products manufactured by ADB SAFEGATE are guaranteed against mechanical, electrical, and physical defects (excluding lamps) which may occur during proper and normal use for a period of two years from the date of ex-works delivery, and are guaranteed to be merchantable and fit for the ordinary purposes for which such products are made.



Note

See your applicable sales agreement for a complete warranty description.

Replaced or repaired equipment under warranty falls into the warranty of the original delivery. No new warranty period is started for these replaced or repaired products.

FAA Certified products manufactured by ADB SAFEGATE

ADB SAFEGATE L858 Airfield Guidance Signs are warranted against mechanical and physical defects in design or manufacture for a period of 2 years from date of installation, per FAA AC 150/5345-44 (applicable edition).

ADB SAFEGATE LED products (with the exception of obstruction lighting) are warranted against electrical defects in design or manufacture of the LED or LED specific circuitry for a period of 4 years from date of installation, per FAA EB67 (applicable edition). These FAA certified constant current (series) powered LED products must be installed, interfaced and powered with and through products certified under the FAA Airfield Lighting Equipment Program (ALECP) to be included in this 4 (four) year warranty. This includes, but is not limited to, interface with products such as Base Cans, Isolation Transformers, Connectors, Wiring, and Constant Current Regulators.



Note

See your sales order contract for a complete warranty description.

Replaced or repaired equipment under warranty falls into the warranty of the original delivery. No new warranty period is started for these replaced or repaired products.

Liability



WARNING

Use of the equipment in ways other than described in the catalog leaflet and the manual may result in personal injury, death, or property and equipment damage. Use this equipment only as described in the manual.

ADB SAFEGATE cannot be held responsible for injuries or damages resulting from non-standard, unintended uses of its equipment. The equipment is designed and intended only for the purpose described in the manual. Uses not described in the manual are considered unintended uses and may result in serious personal injury, death or property damage.

Unintended uses, includes the following actions:

- Making changes to equipment that have not been recommended or described in this manual or using parts that are not genuine ADB SAFEGATE replacement parts or accessories.
- Failing to make sure that auxiliary equipment complies with approval agency requirements, local codes, and all applicable safety standards if not in contradiction with the general rules.
- Using materials or auxiliary equipment that are inappropriate or incompatible with your ADB SAFEGATE equipment.
- Allowing unskilled personnel to perform any task on or with the equipment.

Copyright Statement

This manual or parts thereof may not be reproduced, stored in a retrieval system, or transmitted, in any form or by any means, electronic, mechanical, photocopying, recording, nor otherwise, without the author's prior written consent.

This manual could contain technical inaccuracies or typographical errors. The author reserves the right to revise this manual from time to time in the contents thereof without obligation of the author to notify any person of such revision or change. Details and values given in this manual are average values and have been compiled with care. They are not binding, however, and the author disclaims any liability for damages or detriments suffered as a result of reliance on the information given herein or the use of products, processes or equipment to which this manual refers. No warranty is made that the use of the information or of the products, processes or equipment to which this manual refers will not infringe any third party's patents or rights. The information given does not release the buyer from making their own experiments and tests.

Table of Contents

1.0 Safety	1
1.1 Safety Messages.....	1
1.1.1 Introduction to Safety.....	2
1.1.2 Intended Use.....	2
1.1.3 Material Handling Precautions: Storage.....	3
1.1.4 Material Handling Precautions: Fasteners.....	3
1.1.5 Maintenance Safety.....	3
1.1.6 Material Handling Precautions, ESD.....	4
1.1.7 Arc Flash and Electric Shock Hazard.....	4
2.0 Introduction	5
2.1 LED Elevated Runway Guard Light	5
2.2 Theory of Operation	9
2.2.1 L-804 Runway Guard Light: Required Equipment	9
2.2.2 LED Light Engine.....	10
3.0 Parts	11
3.1 Parts Diagrams.....	12
3.1.1 Spare Parts List.....	15
A.0 Support	17
A.1 ADB SAFEGATE Website.....	18
A.2 Recycling	19
A.2.1 Local Authority Recycling.....	19
A.2.2 ADB SAFEGATE Recycling.....	19

List of Figures

Figure 1: L-804 ERGL Runway Guard Light (shown without tether)	5
Figure 2: ERGL Main Components Final Assembly	12
Figure 3: ERGL Main Components Enclosure Assembly	13
Figure 4: ERGL LED Engine Feed Thru Components	13
Figure 5: ERGL PCB Assembly	14
Figure 6: Voltage Driven	14
Figure 7: Current Driven	14

List of Tables

Table 1: Required Equipment Supplied	9
Table 2: Required Equipment Not Supplied	9
Table 3: Average Measured Intensities	10
Table 4: Spare Parts	15

1.0 Safety

Introduction to Safety







This section contains general safety instructions for installing and using ADB SAFEGATE equipment. Some safety instructions may not apply to the equipment in this manual. Task- and equipment-specific warnings are included in other sections of this manual where appropriate.

1.1 Safety Messages

HAZARD Icons used in this manual

For all HAZARD symbols in use, see the Safety section. All symbols must comply with ISO and ANSI standards.

Carefully read and observe all safety instructions in this manual, which alert you to safety hazards and conditions that may result in personal injury, death or property and equipment damage and are accompanied by the symbols shown below.

	<p>WARNING</p> <p>Failure to observe a warning may result in personal injury, death or equipment damage.</p>
	<p>DANGER – Risk of electrical shock or ARC FLASH</p> <p>Disconnect equipment from line voltage. Failure to observe this warning may result in personal injury, death, or equipment damage. ARC Flash may cause blindness, severe burns or death.</p>
	<p>WARNING – Wear personal protective equipment</p> <p>Failure to observe may result in serious injury.</p>
	<p>WARNING – Do not touch</p> <p>Failure to observe this warning may result in personal injury, death, or equipment damage.</p>
	<p>CAUTION</p> <p>Failure to observe a caution may result in equipment damage.</p>
	<p>ELECTROSTATIC SENSITIVE DEVICES</p> <p>This equipment may contain electrostatic devices.</p>

Qualified Personnel

	<p>Important Information</p> <p>The term qualified personnel is defined here as individuals who thoroughly understand the equipment and its safe operation, maintenance and repair. Qualified personnel are physically capable of performing the required tasks, familiar with all relevant safety rules and regulations and have been trained to safely install, operate, maintain and repair the equipment. It is the responsibility of the company operating this equipment to ensure that its personnel meet these requirements.</p> <p>Always use required personal protective equipment (PPE) and follow safe electrical work practice.</p>
---	---

1.1.1 Introduction to Safety



CAUTION

Unsafe Equipment Use

This equipment may contain electrostatic devices, hazardous voltages and sharp edges on components

- Read installation instructions in their entirety before starting installation.
- Become familiar with the general safety instructions in this section of the manual before installing, operating, maintaining or repairing this equipment.
- Read and carefully follow the instructions throughout this manual for performing specific tasks and working with specific equipment.
- Make this manual available to personnel installing, operating, maintaining or repairing this equipment.
- Follow all applicable safety procedures required by your company, industry standards and government or other regulatory agencies.
- Install all electrical connections to local code.
- Use only electrical wire of sufficient gauge and insulation to handle the rated current demand. All wiring must meet local codes.
- Route electrical wiring along a protected path. Make sure they will not be damaged by moving equipment.
- Protect components from damage, wear, and harsh environment conditions.
- Allow ample room for maintenance, panel accessibility, and cover removal.
- Protect equipment with safety devices as specified by applicable safety regulations
- If safety devices must be removed for installation, install them immediately after the work is completed and check them for proper functioning prior to returning power to the circuit.

Failure to follow these instructions can result in serious injury, death or equipment damage

Additional Reference Materials



Important Information

- IEC – International Standards and Conformity Assessment for all electrical, electronic and related technologies.
- IEC 60364 – Electrical Installations in Buildings.
- CSA – C22.2 No.180:13 (R2018), series isolating transformers for airport lighting.
- FAA Advisory: AC 150/5340-26 (current edition), Maintenance of Airport Visual Aid Facilities.
- Maintenance personnel must refer to the maintenance procedure described in the ICAO Airport Services Manual, Part 9.
- ANSI/NFPA 79, Electrical Standards for Metalworking Machine Tools.
- National and local electrical codes and standards.

1.1.2 Intended Use



CAUTION

Use this equipment as intended by the manufacturer.

This equipment is designed to perform a specific function. Do not use this equipment for other purposes.

Failure to follow this instruction can result in serious injury, death or equipment damage.

1.1.3 Material Handling Precautions: Storage



CAUTION

Improper Storage

Store this equipment properly

- If equipment is to be stored prior to installation, it must be protected from the weather elements and kept free of condensation and dust.

Failure to follow this instruction can result in equipment damage

1.1.4 Material Handling Precautions: Fasteners



DANGER

FOREIGN OBJECT DAMAGE - FOD

THIS EQUIPMENT MAY CONTAIN FASTENERS THAT CAN LOOSEN UNLESS TORQUED PROPERLY.

- ONLY USE FASTENERS OF THE SAME TYPE AS ORIGINALLY SUPPLIED WITH THE EQUIPMENT.
- USE OF INCORRECT COMBINATION OF GASKETS, BOLTS AND NUTS CAN CAUSE SEVERE DAMAGE TO THE PRODUCT AND CREATE MULTIPLE SAFETY RISKS .
- YOU NEED TO KNOW WHAT BASE THE LIGHT FIXTURE WILL BE INSTALLED IN, IN ORDER TO CHOOSE THE CORRECT GASKET, BOLTS AND NUTS.
- BOLT TYPE, LENGTH, AND TORQUE VALUE ARE DETERMINED BY TYPE OF BASE, HEIGHT OF SPACERS USED, AND CLAMP FORCE REQUIRED IN FAA ENGINEERING BRIEF NO 83 (LATEST REVISION).
- USE ONLY ANTI-VIBRATION WASHERS WITH THE FIXING BOLTS AS DEFINED IN FAA EB 83 (LATEST EDITION) TO AVOID THE RISK OF LOOSENING BOLTS . DO NOT USE OF ANY OTHER TYPE OF WASHER (SUCH AS SPLIT-LOCK WASHERS). FOR INSTALLATION OTHER THAN FAA, USE THE BASE CAN MANUFACTURER'S RECOMMENDATIONS.
- ALWAYS TIGHTEN THE FASTENERS TO THE RECOMMENDED TORQUE USING A CALIBRATED TORQUE WRENCH.
- APPLY THE RECOMMENDED TYPE OF ADHESIVE AND FOLLOW THE ADHESIVE INSTRUCTIONS CAREFULLY.

FAILURE TO FOLLOW THESE WARNINGS MAY CAUSE THE FASTENERS TO LOOSEN, POSSIBLY DAMAGING THE EQUIPMENT. THIS CAN LEAD TO THE HIGHLY DANGEROUS SITUATION OF FOD, WITH POTENTIALLY LETHAL CONSEQUENCES.



Note

To minimize the risk of errors, the ADB SAFEGATE Sales Representative will have information on which gasket goes with which base. This information is also provided in the product Data sheets, the User Manuals and the Spare Part Lists.

1.1.5 Maintenance Safety



DANGER

ELECTRIC SHOCK HAZARD

THIS EQUIPMENT MAY CONTAIN ELECTROSTATIC DEVICES

- DO NOT OPERATE A SYSTEM THAT CONTAINS MALFUNCTIONING COMPONENTS. IF A COMPONENT MALFUNCTIONS, TURN THE SYSTEM OFF IMMEDIATELY.
- DISCONNECT AND LOCK OUT ELECTRICAL POWER.
- ALLOW ONLY QUALIFIED PERSONNEL TO MAKE REPAIRS OR REPLACE MALFUNCTIONING COMPONENTS ACCORDING TO INSTRUCTIONS PROVIDED IN MANUAL.

FAILURE TO FOLLOW THESE INSTRUCTIONS CAN RESULT IN DEATH OR EQUIPMENT DAMAGE

1.1.6 Material Handling Precautions, ESD



CAUTION

Electrostatic Sensitive Devices

This equipment may contain electrostatic devices

- Protect from electrostatic discharge.
- Electronic modules and components should be touched only when this is unavoidable e.g. soldering, replacement.
- Before touching any component of the cabinet you shall bring your body to the same potential as the cabinet by touching a conductive earthed part of the cabinet.
- Electronic modules or components must not be brought in contact with highly insulating materials such as plastic sheets, synthetic fiber clothing. They must be laid down on conductive surfaces.
- The tip of the soldering iron must be grounded.
- Electronic modules and components must be stored and transported in conductive packing.

Failure to follow this instruction can result in equipment damage

1.1.7 Arc Flash and Electric Shock Hazard



DANGER

SERIES CIRCUITS HAVE HAZARDOUS VOLTAGES

THIS EQUIPMENT PRODUCES HIGH VOLTAGES TO MAINTAIN THE SPECIFIED CURRENT - DO NOT DISCONNECT WHILE ENERGIZED.

- ALLOW ONLY QUALIFIED PERSONNEL TO PERFORM MAINTENANCE, TROUBLESHOOTING, AND REPAIR TASKS.
- ONLY PERSONS WHO ARE PROPERLY TRAINED AND FAMILIAR WITH ADB SAFEGATE EQUIPMENT ARE PERMITTED TO SERVICE THIS EQUIPMENT.
- AN OPEN AIRFIELD CURRENT CIRCUIT IS CAPABLE OF GENERATING >5000 VAC AND MAY APPEAR OFF TO A METER.
- NEVER UNPLUG A DEVICE FROM A CONSTANT CURRENT CIRCUIT WHILE IT IS OPERATING; ARC FLASH MAY RESULT.
- DISCONNECT AND LOCK OUT ELECTRICAL POWER.
- ALWAYS USE SAFETY DEVICES WHEN WORKING ON THIS EQUIPMENT.
- FOLLOW THE RECOMMENDED MAINTENANCE PROCEDURES IN THE PRODUCT MANUALS.
- DO NOT SERVICE OR ADJUST ANY EQUIPMENT UNLESS ANOTHER PERSON TRAINED IN FIRST AID AND CPR IS PRESENT.
- CONNECT ALL DISCONNECTED EQUIPMENT GROUND CABLES AND WIRES AFTER SERVICING EQUIPMENT. GROUND ALL CONDUCTIVE EQUIPMENT.
- USE ONLY APPROVED ADB SAFEGATE REPLACEMENT PARTS. USING UNAPPROVED PARTS OR MAKING UNAPPROVED MODIFICATIONS TO EQUIPMENT MAY VOID AGENCY APPROVALS AND CREATE SAFETY HAZARDS.
- CHECK THE INTERLOCK SYSTEMS PERIODICALLY TO ENSURE THEIR EFFECTIVENESS.
- DO NOT ATTEMPT TO SERVICE ELECTRICAL EQUIPMENT IF STANDING WATER IS PRESENT. USE CAUTION WHEN SERVICING ELECTRICAL EQUIPMENT IN A HIGH-HUMIDITY ENVIRONMENT.
- USE TOOLS WITH INSULATED HANDLES WHEN WORKING WITH AIRFIELD ELECTRICAL EQUIPMENT.

FAILURE TO FOLLOW THESE INSTRUCTIONS CAN RESULT IN DEATH OR EQUIPMENT DAMAGE

2.0 Introduction

This section describes the ADB Safegate L-804 ERGL runway guard light. The ERGL runway guard light is an elevated light fixture consisting of two LED Engines mounted side by side in the same housing that alternately flash 45-50 times per minute in yellow to identify taxiway holding position lines. It is also available in red for special applications. The assembly is required by FAA specifications to mount on a heavy duty baseplate and be supplied with a tether. The ERGL is available as either a Mode 1 (current driven) or Mode 2 (voltage driven) fixture.

The light fixture is unidirectional and can be aimed in elevation vertically from 0 to +20 degrees, and horizontally ± 20 degrees.

Figure 1: L-804 ERGL Runway Guard Light (shown without tether)



2.1 LED Elevated Runway Guard Light

Compliance with Standards

FAA	L-804(L) AC 150/5345-46 (Current Edition) and the FAA Engineering Brief No. 67. Meets the requirements of Low-Visibility Taxiway Lighting Systems as specified by FAA AC 150/5340-30. ETL Certified.
ICAO	Annex 14, Vol. I, Para 5.3.22 and Appendix 2 Fig. A2-25

Uses

FAA L-804(L) and ICAO

- Runway guard light
- Runway incursion prevention

The L-804(L) Runway Guard Light is an elevated unidirectional flashing yellow light fixture that provides a distinctive warning to pilots that they are approaching a runway holding position and are about to enter an active runway. The L-804(L) is typically installed in pairs, one on either side of the taxiway holding position. The Elevated RGL can also be used in combination with L-852G (In-pavement RGL), L-852S (In-pavement Stop Bar Light), and L-862S (Elevated Stop Bar Light) to provide additional safety under low-visibility conditions on the airfield.

Features and Benefits

- Average LED life of 56,000 hours under high-intensity conditions and more than 150,000 hours under typical operating conditions, resulting in significant reduction or even elimination of ongoing maintenance costs and periodic re-lamping expenses
- Greatly reduces the load on the CCR
- LED RGLs can be powered with any CCR architecture type

- Light output mimics on/off curve of an incandescent lamp. Can be field modified for instant on/off modification, increasing conspicuity.
- Adjustable Light Beam: 0° to 20° vertically; ±20° horizontally
- Flash Rate: Alternating flashes, 45-50 per minute
- Input:
 - FAA Mode 1: 6.6 A Current-Driven - powered by series lighting circuit; intensity varies with current supplied to the fixture by the series circuit
 - FAA Mode 2: Voltage-Driven – powered from a 120 VAC ± 10%, 50/60 Hz or 240 VAC ±10%, 50/60 Hz parallel lighting circuit and equipped with photocell to control intensity. Photocell energizes LEDs at full intensity during high light levels and then reduces intensity to 30% during low ambient light conditions.
- Fixture is fabricated from corrosion-resistant materials, and all exterior surfaces are painted aviation yellow for added protection and visibility
- The two RGL light sources are surrounded by a black face plate and independent visors to reduce the amount of incident sunlight, thereby maximizing the contrast during the ON/OFF cycle
- For additional features common to all of ADB's elevated LED fixtures, see data sheet 3043.
- High-strength 1832RGL base plate is mandatory for FAA applications and should be used for ICAO applications. For more details see data sheet 2012.
- Includes frangible column and tether

Monitored RGL Applications



For monitored runway guard light applications, use a LINC 360 Remote for connection to the fixture. Contact the ADB SAFEGATE Sales Department for LINC 360 Remote part number.

Operating Conditions

Temperature:	-40 °F to +131 °F (-40 °C to + 55 °C)
Humidity:	0 to 100%
Wind:	Withstands wind velocities up to 300 mph (480 kph)

Could not find topic with id oc-2087--.

Ordering Code Notes

1. Complies with color and illumination of ICAO Annex 14, Vol. 1, 6th edition specification for Runway Guard Lights. Color only valid with Power options 1-4.
2. Color not recognized by the FAA.
3. 1832RGL base plate is ordered and shipped separately. See datasheet 2012 for details.

4. Shipped from factory preset for incandescent on/off curve light output. Can be field modified for instant on/off operation. It is recommended that instant on/off be implemented only on dedicated 5-step CCR circuits.
5. Not ETL certified.
6. Monitoring Option 1 provides a fault alarm. A dry contact closure is externally connected via a 5-pin plug (supplied) to indicate alarm status. Alarm status can be communicated using a BRITE II Remote.
7. Monitoring Option 2 provides a fault alarm for LINC 360 applications. A dry contact closure is connected to a LINC 360 Remote (Part No. AGC4170) via a cord set adapter (Part No. 44A7024, both purchased separately).
8. Color only valid with Power Options 1, 3, 5 and 6.

Packaging

In cardboard box:	30 × 22 × 17 in (76.2 × 55.9 × 43.2 cm)
Net weight (estimated):	37 lb (16.8 kg)

Electrical Supply

FAA Current-Driven				
6.6 A through a 6.6 A/6.6 A or 20 A/6.6A isolation transformer.				
Unmonitored				
Mode	Fixture Load (Max)	Transformer		
		Size	Load	CCR Load
Mimics Incand. Curve	46 VA	45 W	13 VA	59 VA
Instant On/Off	68 VA	65 W	15 VA	83 VA
Monitored				
Mode	Fixture Load (Max)	Transformer		
		Size	Load	CCR Load
Mimics Incand. Curve	66 VA	65 W	13 VA	79 VA
Instant On/Off	87 VA	100 W	16 VA	103 VA
FAA Voltage-Driven				
Input Voltage	120 VAC, ±10%, 50/60 Hz, 58 VA ¹ 240 VAC, ±10%, 50/60 Hz, 77 VA ¹			
ICAO Current-Driven				
6.6 A through a 6.6A/6.6 A or 20 A/6.6 A isolation transformer				
Unmonitored				
Mode	Fixture Load (Max)	Transformer		
		Size	Load	CCR Load
Mimics Incand. Curve	85 VA	100 W	15 VA	100 VA
Instant On/Off	92 VA	100 W	18 VA	110 VA
Monitored				
Mode	Fixture Load (Max)	Transformer		
		Size	Load	CCR Load
Mimics Incand. Curve	105 VA	100 W	21 VA	126 VA
Instant On/Off	112 VA	100 W	24 VA	136 VA
ICAO Voltage-Driven				
Input Voltage:	120 VAC, ±10%, 50/60 Hz, 67 VA ¹ 240 VAC, ±10%, 50/60 Hz, 36 VA ¹			

¹Maximum for either mimics incandescent curve or instant on/off operation.

2.2 Theory of Operation

The Runway Guard Light is available in two different models: constant current driven (Mode 1) unit and the voltage driven (Mode 2) unit. In the RGL light engine all LEDs are serially connected. Normally an LED failure will open the circuit which discontinues operation of a single light engine.

The brightness control of the current driven ERGL is via the a 2.8A - 6.6A series circuit while the brightness of the voltage driven ERGL is controlled by a photocell input.

The basic operation of the ERGL in both cases is the same. Once powered up, the ERGL alternately flashes one LED light engine and then the other at the commanded brightness setting.

The basic control board has several status LEDs. See [Table 8](#) .

Refer to: “[Electrical Diagrams](#)” on page 29 for monitor wiring connections. One dry switch contact is available for monitoring. If the unit is powered up and operating correctly, the monitoring contact is closed. If any failure is detected, the contact will open. If either LED array has failed, the unit will default to flashing the good LED array, but will open the fault monitoring contact.



WARNING

Electric Shock

Do not work on either the current driven or voltage driven unit with the power on.

2.2.1 L-804 Runway Guard Light: Required Equipment

Refer to [Table 1](#) for required equipment that is supplied. Refer to [Table 2](#) for required equipment that is not supplied. Refer to the *Parts* section for part numbers.

Table 1: Required Equipment Supplied

Description	Quantity
L-804 runway guard light. Includes LED Engines, frangible column, and 2-pin L-823 cordset, or a 4-pin cordset, or a 5-pin cordset with matching harness.	1
Instruction manual	1 per order

Table 2: Required Equipment Not Supplied

Description	Quantity
Level	1
L-867B light base plate (Part Number 1832RGL). This base plate must be ordered as a separate item. Refer to the Warning below for using the L-867B light base.	1
Wire, 1.3 mm ² (AWG 16) (minimum), 600 V–3.3 mm ² (AWG 12) (maximum) 600 V	As required
Ground wire, 13.3 mm ² (AWG 6), solid copper	As required
Ground rods	As required
Torque wrench	As required



WARNING

FOD

Use only the special L-867B heavy duty light base supplied by ADB Safegate. FAA AC 150/5345-46 (current edition) requires the use of a heavy duty baseplate due to high wind loading requirements. Failure to observe this warning will result in damage to the installed L-804 ERGL caused by high wind loads.

2.2.2 LED Light Engine

Two Assemblies with multiple LEDs.

Flash Rate : Flashes alternately 45-50 times per minute.

Minimum Beam Coverage (Main Beam)

±8 degrees horizontal and, ±8 degrees vertical per FAA specifications and ICAO specifications.

Minimum Intensity (Candela)

The FAA and ICAO require 3000 candela. Refer to [Table 3](#) for average measured intensities for the L-804 RGL.

Table 3: Average Measured Intensities

Color	Average Measured Intensities (Candela)
FAA Traffic Signal Yellow and ICAO Yellow	V: 4246 H: 4136

3.0 Parts

To order parts, call ADB Safegate Customer Service or your local representative. Use the accompanying illustration, to describe and locate parts correctly. See the spare parts list to order.

Could not find topic with id oc-2087--.

Ordering Code Notes

1. Complies with color and illumination of ICAO Annex 14, Vol. 1, 6th edition specification for Runway Guard Lights. Color only valid with Power options 1-4.
2. Color not recognized by the FAA.
3. 1832RGL base plate is ordered and shipped separately. See datasheet 2012 for details.
4. Shipped from factory preset for incandescent on/off curve light output. Can be field modified for instant on/off operation. It is recommended that instant on/off be implemented only on dedicated 5-step CCR circuits.
5. Not ETL certified.
6. Monitoring Option 1 provides a fault alarm. A dry contact closure is externally connected via a 5-pin plug (supplied) to indicate alarm status. Alarm status can be communicated using a BRITE II Remote.
7. Monitoring Option 2 provides a fault alarm for LINC 360 applications. A dry contact closure is connected to a LINC 360 Remote (Part No. AGC4170) via a cord set adapter (Part No. 44A7024, both purchased separately).
8. Color only valid with Power Options 1, 3, 5 and 6.

3.1 Parts Diagrams

Figure 2: ERGL Main Components Final Assembly

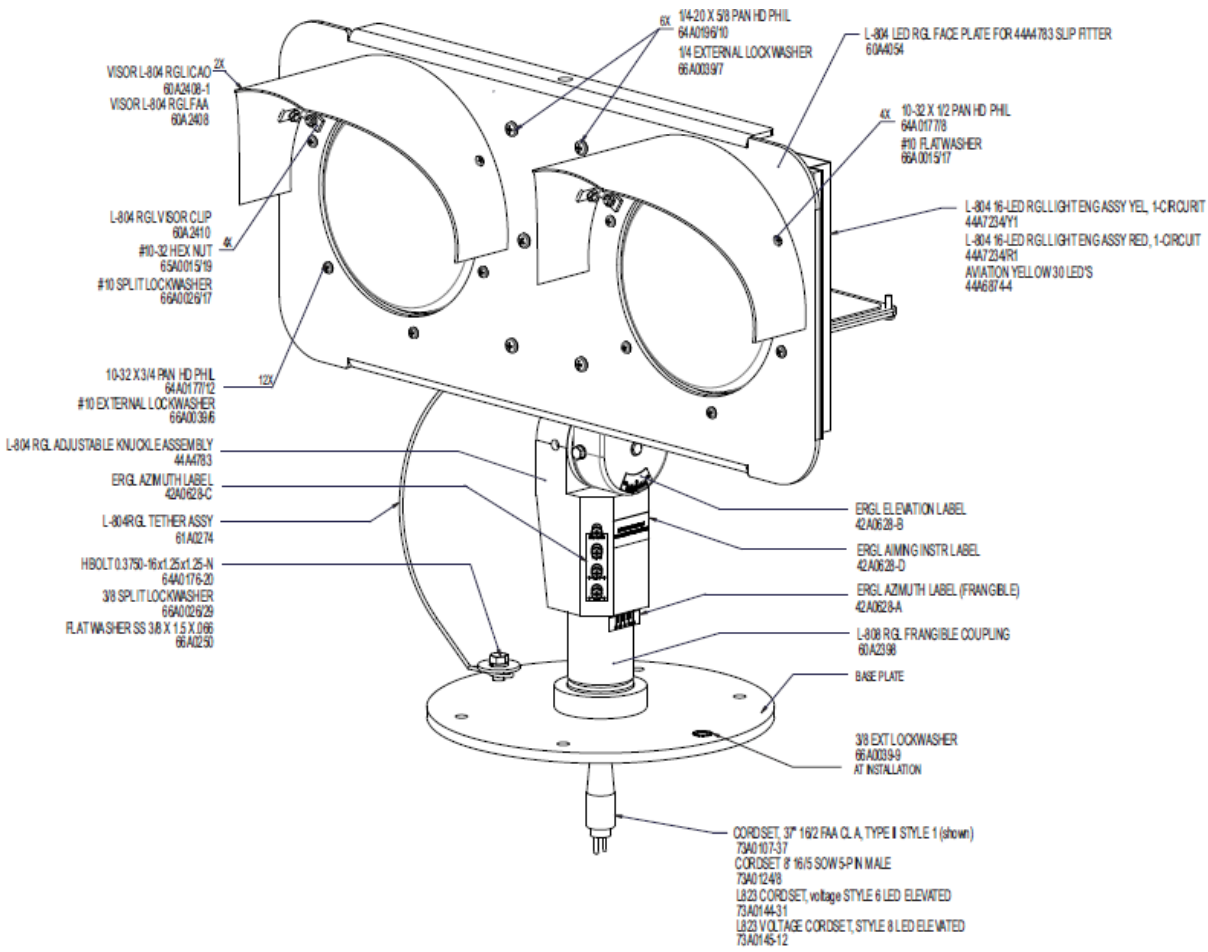

NOTE: See Part List for complete description

Figure 3: ERGL Main Components Enclosure Assembly

Photocell – Mode 2 Only
48A0089 (120 V) or 48A0089-240 (240 V)

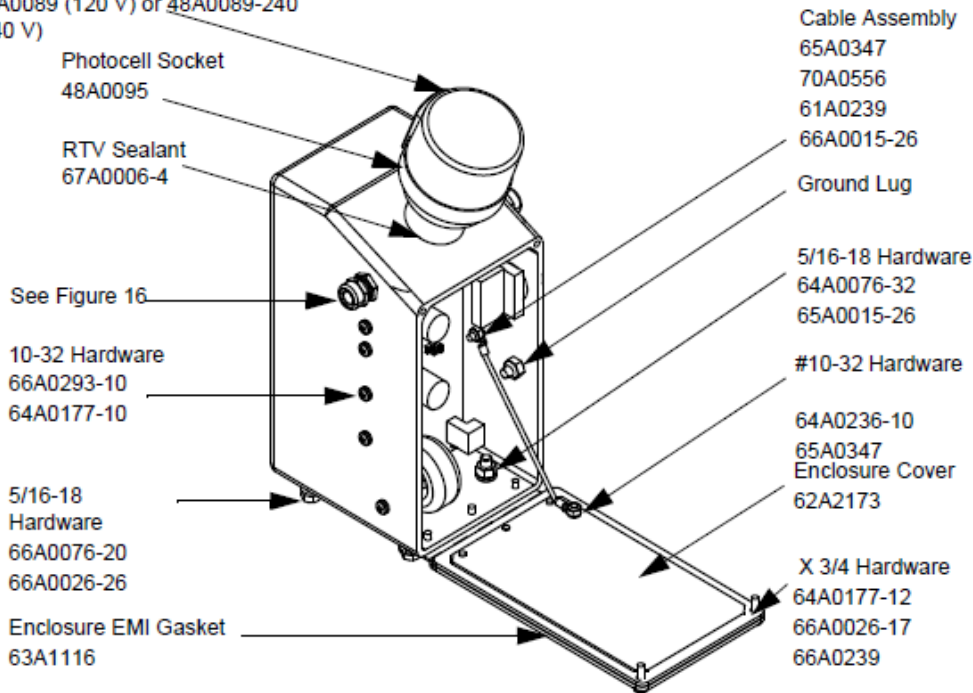

NOTE: See Part List for complete description.

Figure 4: ERGL LED Engine Feed Thru Components

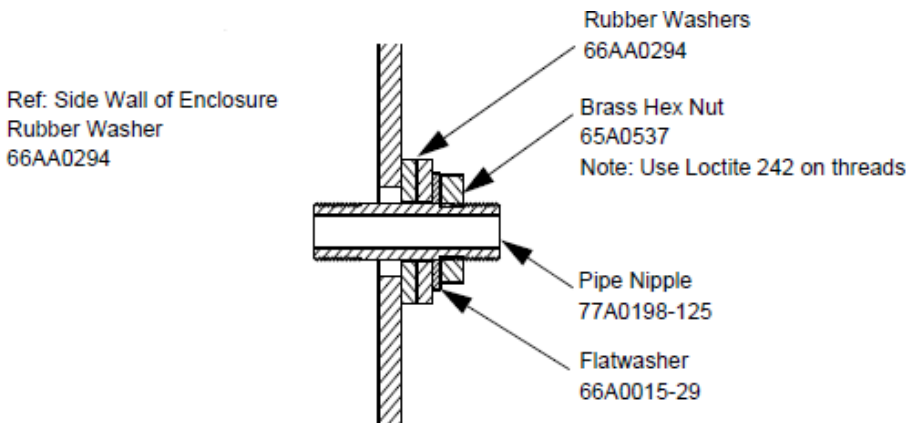

NOTE: See Part List for complete description.

Figure 5: ERGL PCB Assembly

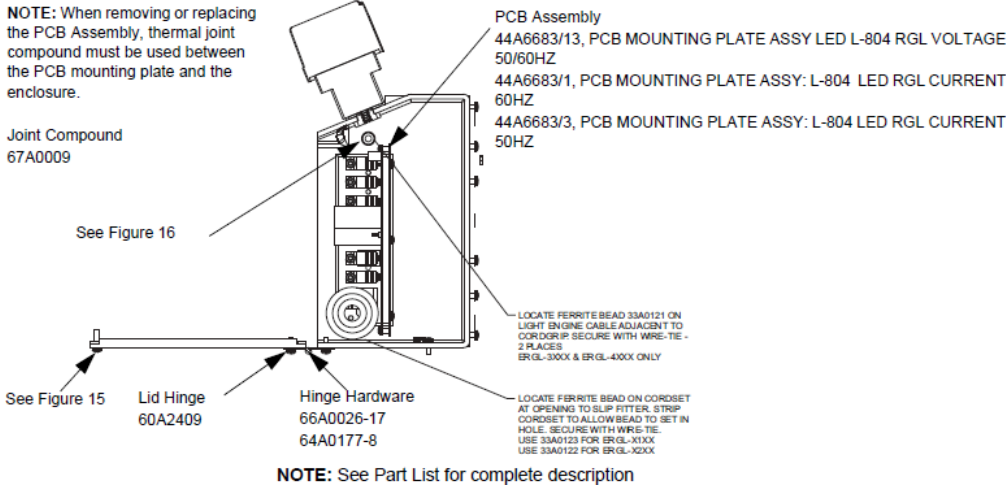

Figure 6: Voltage Driven

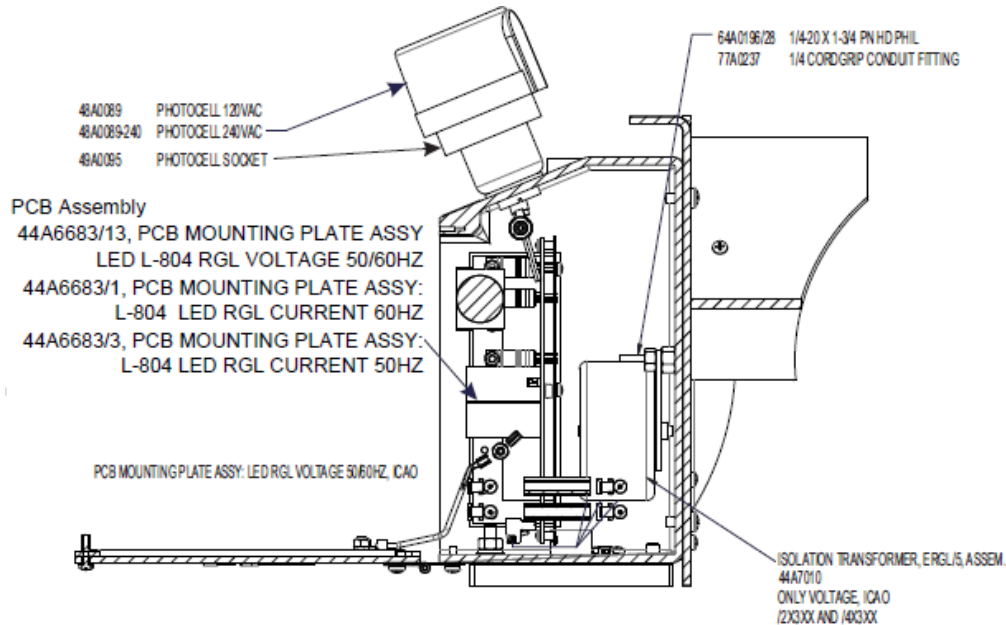
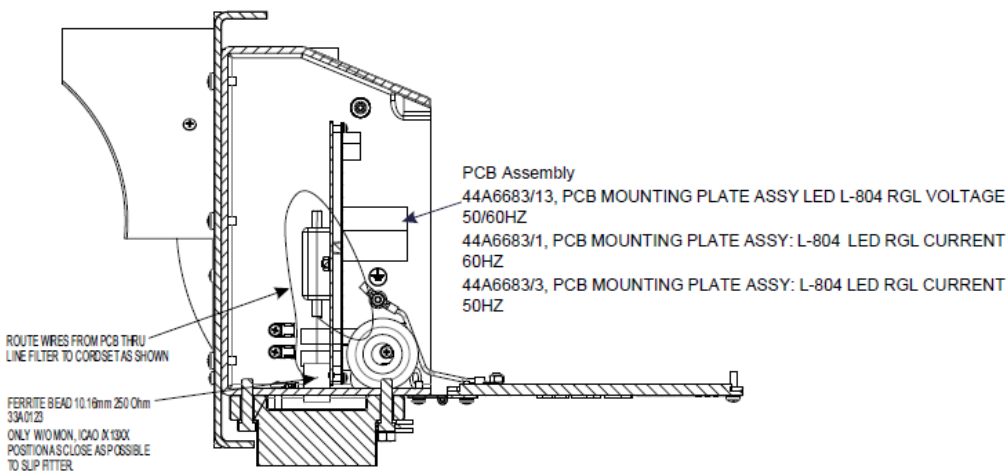

Figure 7: Current Driven



3.1.1 Spare Parts List

Table 4: Spare Parts

Description	Part No.
Base plate, L-867B heavy-duty	1832RGL
Canopy (FAA)	60A2408
Canopy (ICAO)	60A2408-1S
Canopy brackets	60A2410
Frangible column, 2 - 11.5 TPI (Used with 1832RGL)	60A2398
Frangible coupling, 11 TPI threaded (Normally used in metric applications. Not for use with 1832RGL base plate)	60A2398-1
Fuse, 1.5A (voltage-driven, mounted on PCB)	47A0179-5
Gasket, EMI, enclosure	63A1116
Gasket, lens	63A1122
Lens, clear	63A1123
On/Off switch, current-driven	45A0456-1
On/Off switch, voltage-driven	45A0474
Photocell, 120 VAC	48A0089
Photocell, 240 VAC	48A0089-240
Photocell socket	49A0095
Power supply ass'y, 16 or 24 LED light engine, current-driven, 60Hz	44A6683-1
Power supply ass'y, 16 or 24 LED light engine, current-driven, 50Hz ¹	44A6683-3
Power supply ass'y, 16 LED light engine, voltage-driven, 50/60Hz ¹	44A6683-13
Power supply ass'y, 24 LED light engine, voltage-driven, 50/60 Hz ¹	44A6683-2
Power supply ass'y, 30 LED, 95-264 VAC, 50/60 Hz ¹	44A6683-10
Power supply ass'y, 30 LED, current driven, 50 Hz ¹	44A6683-11
Power supply ass'y, 30 LED, current driven, 60 Hz ¹	44A6683-12

¹ Includes power supply PC board, heat-sink, and mounting bracket. Standard LED board has 16 LEDs (since 2015); earlier versions may use 24 or 30 LEDs.

Appendix A: Support

Our experienced engineers are available for support and service at all times, 24 hour/7 days a week. They are part of a dynamic organization making sure the entire ADB SAFEGATE is committed to minimal disturbance for airport operations.

ADB SAFEGATE Support

Technical Support – Global

Customers in Europe, the Middle East, Africa and Asia Pacific are more than welcome to our portal for technical support. Trained in all areas of system issues, troubleshooting, quality control and technical assistance, our highly experienced Technical support specialists are available 24 hours a day, seven days a week to provide assistance over the phone.

Europe: **+32-2-722-17-11**

China: **+86-10-8476-0106**

Middle East and Africa: **+971-4-452-7575**

In the Americas, we also offer live technical support.

Live Technical Support – Americas

If at any time you have a question or concern about your product, contact ADB SAFEGATE's US-based technical support specialists, available 24 hours a day, seven days a week, to assist you via phone.

ADB SAFEGATE Americas Technical Service & Support (US & Canada) :**+1-800-545-4157**

ADB SAFEGATE Americas Technical Service & Support (Canada): **+1-905-631-1597**

ADB SAFEGATE Americas Technical Service & Support (International): **+1-614-861-1304**. For technical service press 3 and for sales support press 4.

We can also be reached via email during regular business hours.

Airfield and Gate: **techservice.us@adbsafegate.com**

Gate: **gateservice.us@adbsafegate.com**

We look forward to working with you!

Before You Call

When you have an airfield lighting or control system problem, prior to calling, please ensure the following:

- Review the product's manual and troubleshooting guide.
- Be located with the product ready to troubleshoot.
- Have all necessary information available: airport code/company name, customer id number, contact phone number/email address, product/part number.
- Have all necessary tools that may be needed at hand.

When calling about an issue with Safedock A-VDGS, we can serve you better if you collect the following information before you call:

- Relevant information regarding the issue you are calling about, such as gate number, flight number, aircraft type and time of the event.
- What, if any, actions have been taken to resolve the issue prior to the call.
- If available, provide a CCTV recording of the incident to aid in aligning the information from the Safedock log file.

For more information, see www.adbsafegate.com, contact ADB SAFEGATE Support via email at **support@adbsafegate.com**.



A.1 ADB SAFEGATE Website

The ADB SAFEGATE website, www.adbsafegate.com, offers information regarding our airport solutions, products, company, news, links, downloads, references, contacts and more.

A.2 Recycling

A.2.1 Local Authority Recycling

The disposal of ADB SAFEGATE products is to be made at an applicable collection point for the recycling of electrical and electronic equipment. The correct disposal of equipment prevents any potential negative consequences for the environment and human health, which could otherwise be caused by inappropriate waste handling. The recycling of materials helps to conserve natural resources. For more detailed information about recycling of products, contact your local authority city office.

A.2.2 ADB SAFEGATE Recycling

ADB SAFEGATE is fully committed to environmentally-conscious manufacturing with strict monitoring of our own processes as well as supplier components and sub-contractor operations. ADB SAFEGATE offers a recycling program for our products to all customers worldwide, whether or not the products were sold within the European Union (EU).

ADB SAFEGATE products and/or specific electrical and electronic component parts which are fully removed/separated from any customer equipment and returned will be accepted for our recycling program.

All items returned must be clearly labeled as follows:

- For Restriction of Hazardous Substances (*RoHS*)/Waste Electrical and Electronic Equipment (*WEEE*) Recycling
- Sender contact information (Name, Business Address, Phone number).
- Main Unit Serial Number.

ADB SAFEGATE will continue to monitor and update according for any future requirements for *EU directives* as and when *EU member states* implement new *regulations* and or *amendments*. It is our aim to maintain our *compliance plan* and assist our customers.

WWW.ADBSAFEGATE.COM

Empowering the Airside Evolution

SMARTER. BETTER. NOW.

