



AXON Runway Inset Lights, 8-inch and 12-inch

Runway Centerline, L-850A(L); Runway Touchdown Zone, L-850B(L); Runway Edge 45 m, L-850C(L); ICAO Runway Edge 60 m; FAA L-850D(L) Threshold and Threshold/End; Runway End, L-850D(L); Runway Takeoff/Hold Light, L-850T(L); ICAO Stopway 45 m; ICAO Stopway 60 m; ICAO Rapid Exit Taxiway Indicator Light; Runway Guard Light, L-852G(L);

User Manual

UM-5055, Rev. 1.0.23, 2024/01/17

**ADB
SAFEGATE**

A.0 Disclaimer / Standard Warranty

CE certification

The equipment listed as CE certified means that the product complies with the essential requirements concerning safety and hygiene. The European directives that have been taken into consideration in the design are available on written request to ADB SAFEGATE.

ETL certification

The equipment listed as ETL certified means that the product complies with the essential requirements concerning safety and C22.2 No.180:13 (R2018) regulations. The CSA directives that have been taken into consideration in the design are available on written request to ADB SAFEGATE.

All Products Guarantee

ADB SAFEGATE will correct by repair or replacement per the applicable guarantee below, at its option, equipment or parts which fail because of mechanical, electrical or physical defects, provided that the goods have been properly handled and stored prior to installation, properly installed and properly operated after installation, and provided further that Buyer gives ADB SAFEGATE written notice of such defects after delivery of the goods to Buyer. Refer to the Safety section for more information on Material Handling Precautions and Storage precautions that must be followed.

ADB SAFEGATE reserves the right to examine goods upon which a claim is made. Said goods must be presented in the same condition as when the defect therein was discovered. ADB SAFEGATE further reserves the right to require the return of such goods to establish any claim.

ADB SAFEGATE's obligation under this guarantee is limited to making repair or replacement within a reasonable time after receipt of such written notice and does not include any other costs such as the cost of removal of defective part, installation of repaired product, labor or consequential damages of any kind, the exclusive remedy being to require such new parts to be furnished.

ADB SAFEGATE's liability under no circumstances will exceed the contract price of goods claimed to be defective. Any returns under this guarantee are to be on a transportation charges prepaid basis. For products not manufactured by, but sold by ADB SAFEGATE, warranty is limited to that extended by the original manufacturer. This is ADB SAFEGATE's sole guarantee and warranty with respect to the goods; there are no express warranties or warranties of fitness for any particular purpose or any implied warranties of fitness for any particular purpose or any implied warranties other than those made expressly herein. All such warranties being expressly disclaimed.

Standard Products Guarantee

Products manufactured by ADB SAFEGATE are guaranteed against mechanical, electrical, and physical defects (excluding lamps) which may occur during proper and normal use for a period of two years from the date of ex-works delivery, and are guaranteed to be merchantable and fit for the ordinary purposes for which such products are made.



Note

See your applicable sales agreement for a complete warranty description.

Replaced or repaired equipment under warranty falls into the warranty of the original delivery. No new warranty period is started for these replaced or repaired products.

FAA Certified products manufactured by ADB SAFEGATE

ADB SAFEGATE L858 Airfield Guidance Signs are warranted against mechanical and physical defects in design or manufacture for a period of 2 years from date of installation, per FAA AC 150/5345-44 (applicable edition).

ADB SAFEGATE LED products (with the exception of obstruction lighting) are warranted against electrical defects in design or manufacture of the LED or LED specific circuitry for a period of 4 years from date of installation, per FAA EB67 (applicable edition). These FAA certified constant current (series) powered LED products must be installed, interfaced and powered with and through products certified under the FAA Airfield Lighting Equipment Program (ALECP) to be included in this 4 (four) year warranty. This includes, but is not limited to, interface with products such as Base Cans, Isolation Transformers, Connectors, Wiring, and Constant Current Regulators.



Note

See your sales order contract for a complete warranty description.

Replaced or repaired equipment under warranty falls into the warranty of the original delivery. No new warranty period is started for these replaced or repaired products.

Liability



WARNING

Use of the equipment in ways other than described in the catalog leaflet and the manual may result in personal injury, death, or property and equipment damage. Use this equipment only as described in the manual.

ADB SAFEGATE cannot be held responsible for injuries or damages resulting from non-standard, unintended uses of its equipment. The equipment is designed and intended only for the purpose described in the manual. Uses not described in the manual are considered unintended uses and may result in serious personal injury, death or property damage.

Unintended uses, includes the following actions:

- Making changes to equipment that have not been recommended or described in this manual or using parts that are not genuine ADB SAFEGATE replacement parts or accessories.
- Failing to make sure that auxiliary equipment complies with approval agency requirements, local codes, and all applicable safety standards if not in contradiction with the general rules.
- Using materials or auxiliary equipment that are inappropriate or incompatible with your ADB SAFEGATE equipment.
- Allowing unskilled personnel to perform any task on or with the equipment.

Copyright Statement

This manual or parts thereof may not be reproduced, stored in a retrieval system, or transmitted, in any form or by any means, electronic, mechanical, photocopying, recording, nor otherwise, without the author's prior written consent.

This manual could contain technical inaccuracies or typographical errors. The author reserves the right to revise this manual from time to time in the contents thereof without obligation of the author to notify any person of such revision or change. Details and values given in this manual are average values and have been compiled with care. They are not binding, however, and the author disclaims any liability for damages or detriments suffered as a result of reliance on the information given herein or the use of products, processes or equipment to which this manual refers. No warranty is made that the use of the information or of the products, processes or equipment to which this manual refers will not infringe any third party's patents or rights. The information given does not release the buyer from making their own experiments and tests.

TABLE OF CONTENTS

1.0 Safety	1
1.1 Safety Messages	1
1.1.1 Introduction to Safety	2
1.1.2 Intended Use	3
1.1.3 Material Handling Precautions: Storage	3
1.1.4 Operation Safety	3
1.1.5 Maintenance Safety	4
1.1.6 Material Handling Precautions: Fasteners	4
1.1.7 Material Handling Precautions, ESD	5
2.0 About this Manual	7
2.1 How to work with the Manual	7
2.2 Abbreviations and Terms	7
3.0 Introduction	9
3.1 Product Information	10
3.2 Dimensions and Weight	14
4.0 Installation	15
4.1 Unpacking the Unit	15
4.2 Tools Required	15
4.3 Installation Overview	16
4.3.1 Installation	16
4.3.2 Typical L-868 Assembly	17
4.3.3 INTEROPERABILITY	18
4.3.4 Safety Considerations	18
4.3.5 Photobiological safety	19
4.3.6 Remote RRU401.5 Programming Procedure for RSRG Autonomous Runway Guard Light	19
4.3.7 Testing for Leaks	20
4.3.8 Verify Input Requirements and Equipment Needed	20
4.3.9 Inspect on Delivery	20
4.3.10 Installation and Removal of the 8- & 12-inch Light Fixture	21
4.4 Toe-In	23
4.5 Light Emission Directions	24
4.5.1 Definition of Light Emission Directions	24
5.0 Maintenance	25
5.1 Basic Maintenance Program	25
5.2 Recommended Maintenance Program for optimal Service Life	26
5.2.1 Recommendation	28
5.3 Workshop Maintenance	30
5.3.1 Opening a Light Fixture — disconnecting the Bottom Pan from the Top Cover	31
5.3.2 Close a Light Fixture — connect the Bottom Pan to the Top Cover	32
5.3.3 Replace the Wire Harnesses	34
5.3.4 Replace the Light Engine Assembly	35
5.3.5 Replace the Prism and its Gasket	36
5.3.6 Replace the Top Cover Assembly	39
5.3.7 Replace the Bottom Cover Assembly	40
5.3.8 Replace the secondary Cable — SJO cord set	41
5.3.9 Replace the Secondary Cable — Style-6 Cord Set	45
5.3.10 Replace the Secondary Cable — French 3-Pin Cord Set	49
5.3.11 Reset the Fail-Open Converter	53
5.3.12 Check the Light Fixture for Water-tightness	55
6.0 Ordering Codes	59
6.1 Ordering Code LED L - 850A(L) Runway Centerline , L-850B(L) Touchdown Zone (ICAO & FAA)	60
6.2 Ordering Code LED L- 850C(L) Runway Edge 45 m (ICAO & FAA)	61

6.3 Ordering Code LED Runway Edge, 60 m Width (R6 60 m) (ICAO)	62
6.4 Ordering Code LED L- 850D(L) - Threshold, End, and Threshold/End (ICAO & FAA)	63
6.5 Ordering Code LED L- 850T(L) Takeoff/Hold (THL) & (RIL) Runway Intersection (FAA)	64
6.6 Ordering Code LED Takeoff/Hold (THL) & (RIL) Runway Intersection (ICAO)	65
6.7 Ordering Code LED Stopway 45 m (ICAO)	66
6.8 Ordering Code LED Stopway (S6 60 m Width) (ICAO)	67
6.9 Ordering Code LED RETIL (ICAO)	68
6.10 Ordering Code LED L- 852(L) Runway Guard Light (ICAO & FAA)	69
7.0 Spare Parts	71
7.1 Versions and Exploded View	71
7.2 Spare Parts Illustration	72
7.3 Spare Parts - Runway Centerline, L - 850A(L) (ICAO & FAA)	74
7.4 Spare Parts - Touchdown Zone, L - 850B(L) (ICAO & FAA)	79
7.5 Spare Parts - Runway Edge 45 m, L- 850C(L) (ICAO & FAA)	83
7.6 Spare Parts - L- 850D(L) Threshold, Threshold/End FAA, Runway End (ICAO & FAA)	86
7.7 Spare Parts - Takeoff/Hold & Runway Intersection, L-850T(L) (ICAO & FAA)	89
7.8 Spare Parts - Runway Guard Light, L - 852G(L) (ICAO & FAA)	92
8.0 INTEROPERABILITY	97
A.0 POWER TABLE	101
B.0 CABLE LOSS	105
C.0 SUPPORT	107
C.1 ADB SAFEGATE Website	107
C.2 Recycling	107
C.2.1 Local Authority Recycling	107
C.2.2 ADB SAFEGATE Recycling	107

List of Figures

Figure 1: 8-Inch and 12-Inch Fixtures	9
Figure 2: 8-Inch and 12-Inch Fixtures	14
Figure 3: Installation on 8" shallow base	16
Figure 4: Diagram of the Fixture Installed in a 1-Piece Base Can	17
Figure 5: Anti-vibration washer example	17
Figure 6: Remote Configuration	19
Figure 7: 2-Inch Shallow Base, Class 1, Direct-Mounted Fixtures	21
Figure 8: Toe-In	23
Figure 9: Light Emissions Direction	24
Figure 10: Preventive Maintenance	27
Figure 11: Visual Inspection Interval	28
Figure 12: Loosening Pressure Release Screw	31
Figure 13: Gasket Placement	32
Figure 14: Top Cover Placement	32
Figure 15: Star Pattern	33
Figure 16: Dispose Old Wire Harnesses	34
Figure 17: Removal of Light Engine(s) Assembly	35
Figure 18: Star Pattern	35
Figure 19: Removal of Light Engine(s) Assembly	36
Figure 20: Removal of the Prism-Keeper Plate and Prism-Protection Gap Pad	36
Figure 21: Prism Protection Gap Pad Placement	37
Figure 22: Prism-Keeper Plate Installation into the Top Cover	37
Figure 23: Mounting Procedure	37
Figure 24: Light Engine Assembly Mounting Procedure	38
Figure 25: Dispose Old Screws and Old Top Cover	39
Figure 26: Star Pattern	39
Figure 27: Secondary Cable Replacement	41
Figure 28: Disconnecting Secondary Cable	41
Figure 29: Dispose Old Bolt and Cord-Set-Retainer Disc	42
Figure 30: Dispose Old Bolt, Washer and Lock Washer	42
Figure 31: New Cable Gland Gasket Installation	42
Figure 32: Loosen the Cord-Set-Retainer Disc in the Bottom Cover	43
Figure 33: Installation Steps Overview	43
Figure 34: Locking Secondary Cables	44
Figure 35: Secondary Cable Replacement	45
Figure 36: Disconnecting secondary cable	45

Figure 37: Removal of nylon hex nut	46
Figure 38: Dispose old bolt and cord-set-retainer disc	46
Figure 39: New cable gland gasket installation	46
Figure 40: Loosen cord-set-retainer disc in the bottom cover	47
Figure 41: Installation of secondary cable	47
Figure 42: Secure nylon hex nut tightly with a wire tie	47
Figure 43: Tighten new cold-set-retainer bolt	48
Figure 44: Locking secondary cables	48
Figure 45: Disconnecting Secondary Cable	49
Figure 46: Removal of Nylon Hex Nut	49
Figure 47: Dispose of Old Bolt and Cord-Set-Retainer-Disc	50
Figure 48: Dispose of Old Bolt and Washer	50
Figure 49: Installation of New Cable Gland Gasket	50
Figure 50: Loosen Cord-Set-Retainer-Disc in the Bottom Cover	51
Figure 51: Installation of New Secondary Wires	51
Figure 52: Securing Nylon Hex Nut Tightly with a Wire Tie	51
Figure 53: Tighten New Cord-Set-Retainer Bolt	52
Figure 54: Tighten Bolt	52
Figure 55: Locking Secondary Cables	52
Figure 56: Fail-Open 1-Con	53
Figure 57: Fail-Open 2-Con	54
Figure 58: Removal of Pressure-Release Screw	55
Figure 59: Screw the Fitting Hand-Tight	56
Figure 60: 8-Inch Fixtures (Left) & 12-Inch Fixtures (Right)	71
Figure 61: Top Cover Assembly	72
Figure 62: Bottom Pan Assembly, 8-inch	72
Figure 63: Bottom Pan Assembly, 12-inch	72
Figure 64: Bottom Pan Gasket, 8-inch, Package of 10	72
Figure 65: Bottom Pan Gasket, 12-inch Package of 10	72
Figure 66: LED Light Engines Wire Harness, Package of 10	73
Figure 67: Light Engine Assembly, Package of 2	73
Figure 68: Prism Kit, Package of 2	73
Figure 69: Ground Lugs, Package of 5	73
Figure 70: Style-1 Cord Set Cable Clamp, Package of 5	73
Figure 71: Mounting Screws, Package of 100	73
Figure 72: Pressure Release Screws, Package of 5	74
Figure 73: Arctic Kit, Package of 2	74

List of Tables

Table 1: Interoperability matrix — 12 inch	97
Table 2: Interoperability matrix — 8 inch	98

1.0 Safety

Introduction to Safety

This section contains general safety instructions for installing and using ADB SAFEGATE equipment. Some safety instructions may not apply to the equipment in this manual. Task- and equipment-specific warnings are included in other sections of this manual where appropriate.

1.1 Safety Messages

HAZARD Icons used in the manual

For all HAZARD symbols in use, see the Safety section. All symbols must comply with ISO and ANSI standards.

Carefully read and observe all safety instructions in this manual, which alert you to safety hazards and conditions that may result in personal injury, death or property and equipment damage and are accompanied by the symbol shown below.



WARNING
Failure to observe a warning may result in personal injury, death or equipment damage.



DANGER - Risk of electrical shock or ARC FLASH
Disconnect equipment from line voltage. Failure to observe this warning may result in personal injury, death, or equipment damage. ARC Flash may cause blindness, severe burns or death.



WARNING - Wear personal protective equipment
Failure to observe may result in serious injury.



WARNING - Do not touch
Failure to observe this warning may result in personal injury, death, or equipment damage.



CAUTION
Failure to observe a caution may result in equipment damage.



ELECTROSTATIC SENSITIVE DEVICES
This equipment may contain electrostatic devices.

Qualified Personnel



Important Information

The term **qualified personnel** is defined here as individuals who thoroughly understand the equipment and its safe operation, maintenance and repair. Qualified personnel are physically capable of performing the required tasks, familiar with all relevant safety rules and regulations and have been trained to safely install, operate, maintain and repair the equipment. It is the responsibility of the company operating this equipment to ensure that its personnel meet these requirements.

Always use required personal protective equipment (PPE) and follow safe electrical work practice.

1.1.1 Introduction to Safety

CAUTION

Unsafe Equipment Use

This equipment may contain electrostatic devices, hazardous voltages and sharp edges on components

- Read installation instructions in their entirety before starting installation.
- Become familiar with the general safety instructions in this section of the manual before installing, operating, maintaining or repairing this equipment.
- Read and carefully follow the instructions throughout this manual for performing specific tasks and working with specific equipment.
- Make this manual available to personnel installing, operating, maintaining or repairing this equipment.
- Follow all applicable safety procedures required by your company, industry standards and government or other regulatory agencies.
- Install all electrical connections to local code.
- Use only electrical wire of sufficient gauge and insulation to handle the rated current demand. All wiring must meet local codes.
- Route electrical wiring along a protected path. Make sure they will not be damaged by moving equipment.
- Protect components from damage, wear, and harsh environment conditions.
- Allow ample room for maintenance, panel accessibility, and cover removal.
- Protect equipment with safety devices as specified by applicable safety regulations
- If safety devices must be removed for installation, install them immediately after the work is completed and check them for proper functioning prior to returning power to the circuit.



Failure to follow this instruction can result in serious injury or equipment damage

Additional Reference Materials



Important Information

- IEC - International Standards and Conformity Assessment for all electrical, electronic and related technologies.
 - IEC 60364 - Electrical Installations in Buildings.
 - CSA - C22.2 No.180:13 (R2018) Series isolating transformers for airport lighting
 - FAA Advisory: AC 150/5340-26 (current edition), Maintenance of Airport Visual Aid Facilities.
 - Maintenance personnel must refer to the maintenance procedure described in the ICAO Airport Services Manual, Part 9.
 - ANSI/NFPA 79, Electrical Standards for Metalworking Machine Tools.
 - National and local electrical codes and standards.
-

1.1.2 Intended Use



CAUTION

Use this equipment as intended by the manufacturer

This equipment is designed to perform a specific function, do not use this equipment for other purposes

- Using this equipment in ways other than described in this manual may result in personal injury, death or property and equipment damage. Use this equipment only as described in this manual.

Failure to follow this instruction can result in serious injury or equipment damage

1.1.3 Material Handling Precautions: Storage



CAUTION

Improper Storage

Store this equipment properly

- If equipment is to be stored prior to installation, it must be protected from the weather and kept free of condensation and dust.

Failure to follow this instruction can result in equipment damage

1.1.4 Operation Safety



CAUTION

Improper Operation

Do Not Operate this equipment other than as specified by the manufacturer

- Only qualified personnel, physically capable of operating the equipment and with no impairments in their judgment or reaction times, should operate this equipment.
- Read all system component manuals before operating this equipment. A thorough understanding of system components and their operation will help you operate the system safely and efficiently.
- Before starting this equipment, check all safety interlocks, fire-detection systems, and protective devices such as panels and covers. Make sure all devices are fully functional. Do not operate the system if these devices are not working properly. Do not deactivate or bypass automatic safety interlocks or locked-out electrical disconnects or pneumatic valves.
- Protect equipment with safety devices as specified by applicable safety regulations.
- If safety devices must be removed for installation, install them immediately after the work is completed and check them for proper functioning.
- Route electrical wiring along a protected path. Make sure they will not be damaged by moving equipment.
- Never operate equipment with a known malfunction.
- Do not attempt to operate or service electrical equipment if standing water is present.
- Use this equipment only in the environments for which it is rated. Do not operate this equipment in humid, flammable, or explosive environments unless it has been rated for safe operation in these environments.
- Never touch exposed electrical connections on equipment while the power is ON.

Failure to follow these instructions can result in equipment damage

1.1.5 Maintenance Safety

DANGER

Electric Shock Hazard

This equipment may contain electrostatic devices

- Do not operate a system that contains malfunctioning components. If a component malfunctions, turn the system OFF immediately.
- Disconnect and lock out electrical power.
- Allow only qualified personnel to make repairs. Repair or replace the malfunctioning component according to instructions provided in its manual.
-



Failure to follow these instructions can result in death or equipment damage

1.1.6 Material Handling Precautions: Fasteners



DANGER

Foreign Object Damage - FOD

This equipment may contain fasteners that may come loose - torque properly.

- Only use fasteners of the same type as the one originally supplied with the equipment.
- Use of incorrect combination of gaskets, bolts and nuts can create severe damages to the product installation and create safety risk .
- You need to know what base the light fixture will be installed in, in order to chose the correct gasket, bolts and nuts.
- Bolt type, length, and torque value are determined by type of base, height of spacers used, and clamp force required in FAA Engineering Brief No 83 (latest revision).
- Due to the risk of bolts vibrating loose, do not use any type of washer with the fixing bolts (such as split lock washers) other than an anti-vibration washer. Anti-vibration washers as defined in FAA EB 83 (latest edition) must be used. For installations other than FAA, use the base can manufacturer's recommendations.
- Always tighten the fasteners to the recommended torque. Use a calibrated torque wrench and apply the recommended adhesive type.
- Obey the instructions of the adhesives necessary for the fasteners.

Failure to follow these warnings may cause the fasteners to loosen, damage the equipment, potentially to loosen the equipment. This can lead to a highly dangerous situation of FOD, with potential lethal consequences.



Note

To minimize the risk of errors, the ADB SAFEGATE Sales Representative will have information on which gasket goes with which base. This information is also provided in the product Data sheets, the User Manuals and the Spare Part Lists.



CAUTION

Use of incorrect combination of gaskets, bolts and nuts can create severe damages to the product installation and create multiple safety risks.

To obtain a safe and watertight installation the O-ring and retaining bolt stated in the document must be used.

You need to know what base the light fixture will be installed in, in order to choose the correct gasket, bolts and nuts.

Failure to follow these cautions can result in equipment damage or aircraft FOD.

1.1.7 Material Handling Precautions, ESD



CAUTION

Electrostatic Sensitive Devices

This equipment may contain electrostatic devices

- Protect from electrostatic discharge.
- Electronic modules and components should be touched only when this is unavoidable e.g. soldering, replacement.
- Before touching any component of the cabinet you shall bring your body to the same potential as the cabinet by touching a conductive earthed part of the cabinet.
- Electronic modules or components must not be brought in contact with highly insulating materials such as plastic sheets, synthetic fiber clothing. They must be laid down on conductive surfaces.
- The tip of the soldering iron must be grounded.
- Electronic modules and components must be stored and transported in conductive packing.

Failure to follow this instruction can result in equipment damage

2.0 About this Manual

This document includes AXON runway inset light fixture information with a focus on safety, installation and maintenance procedures.

For more information, see www.adbsafegate.com.



Note

It is very important to read this document before any work is started.

This manual covers the following 8-inch and 12-inch fixtures:

- ICAO & FAA L-850A(L) Runway Centerline (RC)
- ICAO & FAA L-850B(L) Runway Touchdown Zone (RZ)
- ICAO & FAA L-850C(L) 45 m Runway Edge (RE)
- ICAO Runway Edge 60 m (R6)
- FAA Threshold and Threshold/End L-850D(L) (RT)
- ICAO & FAA Runway End L-850D(L) (RN)
- ICAO & FAA L-850T(L) Runway Takeoff/Hold Light (RS)
- ICAO Stopway 45 m (SW)
- ICAO Stopway 60 m (S6)
- ICAO Rapid Exit Taxiway Indicator Light (RY)
- ICAO & FAA L-852G(L) Runway Guard Light (RG)

2.1 How to work with the Manual

- Familiarize yourself with the structure and content.
- Carry out the actions completely and in the given sequence.

2.2 Abbreviations and Terms

This document may include the abbreviations and terms listed below.

Abbreviation and term	Description
CAA	Civil Aviation Authority
CCR	Constant Current Regulator
FAA	Federal Aviation Administration
ICAO	International Civil Aviation Organization
IEC	International Electrotechnical Committee
ILCMS	Individual Light Control and Monitoring System
LED	Light Emitting Diode
NATO	North Atlantic Treaty Organization
STAC	Service Technique de l'Aviation Civile (France)
STANAG	Standardization Agreement (NATO)

3.0 Introduction

The all-in-one solution

The 8-inch and 12-inch range is a bi- or unidirectional low protrusion light-emitting diode (LED) inset light fixture, available in multiple versions:

Non-MON	Basic operation providing power only
MON (Fail-open)	A LED light fixture with integrated fail open technology with CCR monitoring compatibility
EQ	Fixture with integrated ILCMS remote utilizing orthogonal frequency-division multiplexing (OFDM) technology providing superior communication interfacing with LINC 360 System.



NOTICE

All Axon light fixtures are equipped with failed LED detection monitoring as required by FAA Engineering Brief 67.

Figure 1: 8-Inch and 12-Inch Fixtures



Runway Inset 8"



Runway Inset 8" with Style-6 cord set



Runway Inset 8" with Style-1 jacketed cord set



Runway Inset 12"



Runway Inset 12" with Style-6 cord set



Runway Inset 12" with Style-1 jacketed cord set

3.1 Product Information

Compliance and Standards

Compliance	Description	Application:	RC-RZ	RE 45 m	R6	RN-RT FAA	RS FAA
Reference DS-XXXX:			5040	5041	5042	5044	5070
FAA	AC 150/5345-46 and the FAA Engineering Brief No. 67		X	X		X	X
ICAO	Annex 14 Volume 1		X	X	X		
EASA	CS-ADR-DSN		X	X	X		
Australia	MOS 139		X	X	X		
Canada	TP 312		X	X	X		
IEC	61827		X	X	X	X	X
NATO	STANAG 3316		X	X	X		
STAC	PRO/STAC/SE/VIS		X	X	X		
UK	CAP 168		X	X			
CE			X	X	X	X	X

Compliance	Description	Application:	RS ICAO	SW 45 m ICAO	S6 60 M ICAO	RY	RG
Reference DS-XXXX:			5100	5047	5097	5092	5043
FAA	AC 150/5345-46 and the FAA Engineering Brief No. 67						X
ICAO	Annex 14 Volume 1		X	X	X	X	X
EASA	CS-ADR-DSN						
Australia	MOS 139			X	X		
Canada	TP 312		X			X	X
IEC	61827		X	X	X	X	X
NATO	STANAG 3316					X	
STAC	PRO/STAC/SE/VIS						
UK	CAP 168						
CE			X	X	X	X	X

Uses RC-RZ

ICAO

- Runway centerline
- Touchdown zone

FAA

- L-850A(L) Runway centerline
- L-850B(L) Touchdown zone

Uses RE 45 m

ICAO

- Runway edge \leq 45 m width runway

FAA

- L-850C(L) Runway edge
- L-850C(L) Displaced threshold

Uses R6 60 m

ICAO

- Runway edge

Uses RT

FAA

- L-850D(L) Runway threshold
- L-850D(L) Runway end
- L-850D(L) Runway threshold/end (bidirectional green and red)

Uses RN

FAA

- L-850D(L) Runway threshold
- L-850D(L) Runway end
- L-850D(L) Runway threshold/end (bidirectional green and red)

Uses RS

ICAO Runway Status Light Applications

- Runway Takeoff/Hold Light
- Runway Intersection Light

FAA Runway Status Light Applications

- L-850T(L) Runway Takeoff/Hold Light
- L-850T(L) Runway Intersection Light

Uses SW 45 m

ICAO and MOS

- Stopway 45 m Wide Runway

Uses S6 60 m

- ICAO**
- Stopway 60 m Width Runway

Uses RY

- ICAO**
- Rapid Exit Taxiway Indicator Light (RETIL)

Uses RG

- ICAO**
- Runway guard light
- FAA**
- L-852G(L) Runway guard light

Features and Benefits

Efficiency

- EQ has an integrated ILCMS remote for use with the LINC 360 system providing high data capacity and resisting degradation from various types of radio effects to provide a superior communication platform
- Precision aimed optics enhancing photometric performance and complementing extended LED life
- Reduced bottom pan profile allowing for very shallow base can installation
- LEDs pulse width modulated (PWM) at 400 Hz optimizing LED performance and eliminating perceptible flicker to a moving human observer throughout the range of brightness steps
- Operates at all steps of constant current regulator technologies designed in compliance with IEC or FAA requirements
- Fully dimmable lights, conforming to the dimming curve of traditional halogen lights
- Low protrusion, high-intensity, Style 3 (≤ 6.35 mm) inset light fixtures
- No negative slope in front of the prisms

Sustainability

- Fully encapsulated all-in-one universal power supplies for Runway, Taxiway, Approach and Omni inset families
- Latest generation LEDs providing a long-lasting light source with high efficiency and low power consumption
- Reinforced top cover substantially exceeding standards to improve durability and longevity
- One single family of fixtures covering all runway, taxiway and approach applications
- IP68 rated enclosure designed for harsh environments; all fastenings are stainless steel
- Reinforced prism available as an option
- Compatible with existing infrastructure allowing for direct replacement of existing LED inset fixtures

Safety

- Improved mechanical design to strengthen and consolidate components, improving the customer maintenance experience
- Fail-open option for compatibility with legacy monitoring systems and optimization of advanced control/ monitoring systems
- Failed-LED Detection as required by Engineering Brief 67D
- Robust lightning protection complying with ANSI/IEEE C62.41-1991; Location Category C2 as required by FAA Eng. Brief 67. Category C2 is defined as a 1.2/50 μ S – 8/20 μ S combination wave, with a peak voltage of 10,000 V and a peak current of 5,000 A

Power Supply

- Non-Monitored — Power only
- Monitored — integrated Fail-open technology
- IQ - Integrated ILCMS remote for RELIANCE IL

Power Supply

- Non-Monitored — Power only
- Monitored — integrated Fail-open technology
- EQ with integrated ILCMS with OFDM technology for use with LINC 360 system

Maintenance and Installation

The light fixture can be installed on an 8-inch or 12-inch base. Gaskets are sold separately. Check what gasket and bolts to order depending on base and installation.

Operating Conditions

Operating temperature	-60 °C to +55 °C / -76 °F to +131 °F
Storage temperature	-60 °C to +80 °C / -76 °F to +176 °F
Humidity	Up to 100%

3.2 Dimensions and Weight

The weight and measurement [A] depends on version of the light fixture.

Version	Weight	Dimension
ICAO/FAA RC – RZ – RG – RS ICAO RY	3 kg / 6.6 lb (8 in)	203 mm / 8 in
ICAO/FAA RC – RZ – RE – RN – RS – RG ICAO R6 – RY – S6, FAA RT	6.8 kg / 15 lb (12 in)	304 mm / 12 in

Figure 2: 8-Inch and 12-Inch Fixtures

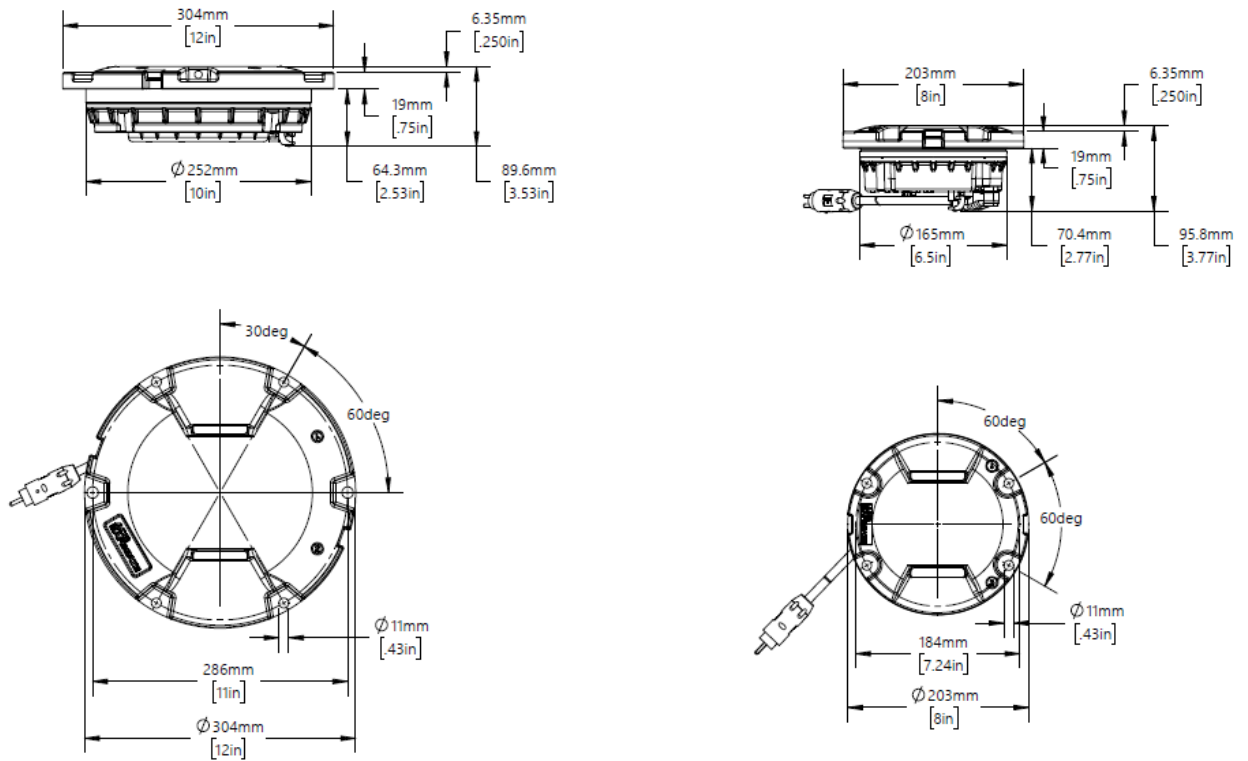

4.0 Installation

Install the inset light fixture in a base provided by ADB SAFEGATE as follows:



Note

If the inset light fixture is to be installed on another type of base or adapter ring not provided by ADB SAFEGATE, contact ADB SAFEGATE.



CAUTION

Use of incorrect combination of gaskets, bolts and nuts can create severe damages to the product installation and create multiple safety risks.

To obtain a safe and watertight installation the O-ring and retaining bolt stated in the document must be used.

You need to know what base the light fixture will be installed in, in order to choose the correct gasket, bolts and nuts.

4.1 Unpacking the Unit

To reduce the possibility of damaging the light assembly, unpack the light fixtures at the installation site. If damage to any equipment is noted, file a claim form with the carrier immediately.

When receiving the light fixture, open the box and verify that the characteristics of the light fixture correspond to the design requirements, such as type, color etc. When installing a light fixture where the control and monitoring function is to be activated at a later stage, make sure to register product information, such as PID/SN and position of the light fixture in, for example, a site documentation table. The information is required for remote activation and administration of control and monitoring functionality from a substation.

4.2 Tools Required

The following tools are recommended for installation.

- Drill / driver with 21 mm (9/16-inch) socket.
- Torque wrench with 21 mm (9/16-inch) socket. ¹
- Large flat head screwdriver to lift edge of fixture to reposition if necessary.
- Air compressor with high pressure nozzle - Optional to assure mounting surface is free of debris.
- One brush or cloth.



Note

Provided that the base intended to receive the light fixture has been properly installed, no other specific tool is required.

¹ Do not use an impact wrench.

4.3 Installation Overview



WARNING

Read the instructions in their entirety before starting installation.

This section provides instructions for installing the in-pavement lights. Refer to airport project plans and specifications for specific installation instructions. The installation must conform to the applicable sections of the National Electric Code and local codes.

4.3.1 Installation

On a shallow base.

The 8" dia. base is secured in the pavement by means of resin. Correct positioning and leveling are obtained with a jig with sighting telescope. Wires between the light and the series transformer are installed either in saw cuts in the pavement filled with resin or in pipes in the lower concrete layers. Mounting on existing or new, larger diameter bases, is made possible by means of dedicated adapter rings.

Figure 3: Installation on 8" shallow base

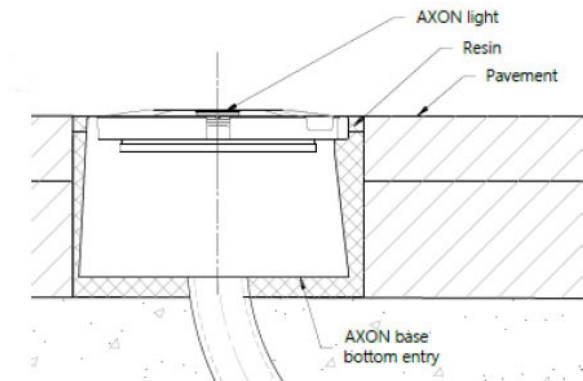

On a FAA L-868B size B steel base.

The 8" dia. light is mounted in an 8" to 12" dia. snow plow or adapter ring bolted onto the base. The 12" fixture is directly mounted without a separate ring. The bases are interconnected by means of conduits protecting the cables. See FAA AC 150/5340-30 for additional design guidance on deep base cans. The series transformer is installed under the light or in a separate pit. See data sheet A.05.120 or DS2012 for more information on base cans.

4.3.2 Typical L-868 Assembly

Figure 4: Diagram of the Fixture Installed in a 1-Piece Base Can

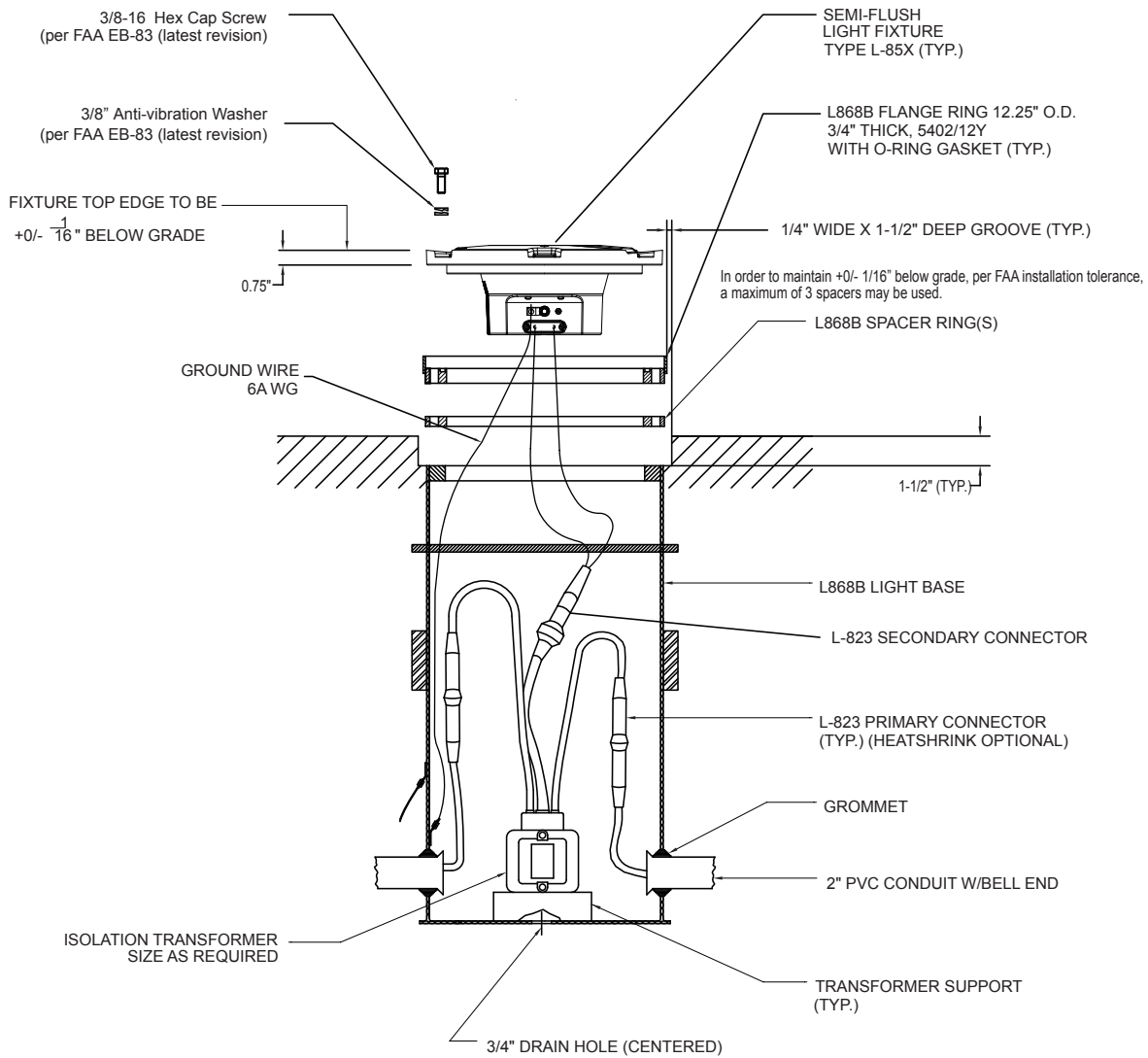

1. Torque according to: FAA EB-83 (latest revision).

Figure 5: Anti-vibration washer example

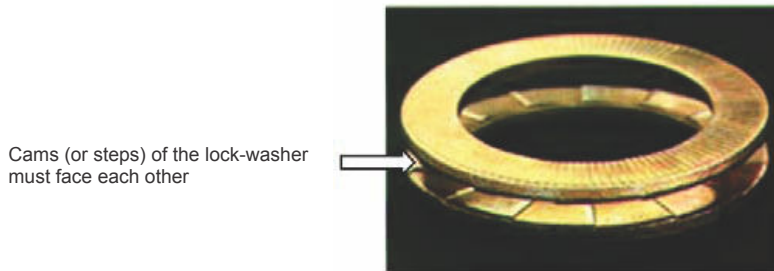



CAUTION

Per FAA AC 150/5340-30, Chapter 10, and FAA Engineering Brief No 83 (latest revision), it is extremely important that other types of washers, such as split washers, must not be used. Failure to use properly installed anti-vibration lock washers will cause mounting bolts to become loose. The cams (or steps) of each half of the lock washer must face each other.

4.3.3 INTEROPERABILITY

Top cover versions



Note

Please check interoperability matrix for information on torque values and compatibility towards different bases.

4.3.4 Safety Considerations

Read the installation section of all system component manuals before starting these steps. A thorough understanding of system components and their requirements will promote safe and efficient installation. See FAA AC 150/5340-30, Design and Installation Details for Airport Visual Aids, and site plans and specifications for field installation of runway and taxiway in-pavement lights.



DANGER

Failure to follow these safety procedures can result in personal injury or death.

- Allow only qualified personnel to install ADB SAFEGATE and auxiliary equipment. Use only approved equipment. Using unapproved equipment in an approved system may void FAA approvals. Observe and follow the safety instructions in this document and all other related documentation.
 - Make sure all equipment is rated and approved for the environment where it is being used.
 - Follow all instructions for installing components and accessories.
 - Install all electrical connections in compliance with local and national codes and regulations.
 - Use only electrical wire of sufficient gauge and insulation to handle the rated current demand. All wiring must meet local and national codes.
 - Route electrical wiring along a protected path. Make sure it will not be damaged by moving equipment.
 - Protect components from damage, wear and harsh environmental conditions.
 - Allow ample clearance for maintenance, panel accessibility and cover removal.
 - Protect equipment with safety devices as specified by applicable safety regulations.
 - If safety devices must be removed for installation, reinstall them immediately after the work is completed and check them for proper functioning.
 - The cord set must be protected prior to installation.
-

4.3.5 Photobiological safety



CAUTION

Photobiological safety conforming with IEC 62471

RISK GROUP 0 or 1: Optical radiation emitted from LED lights may be harmful to the eyes. Do not stare with at the light source with bare eyes at a fixture operating at high intensity. Use protection goggles or similar protection method.

Goggles with a transmission factor not higher than 5% in the 400-530 nm band have been tested and provide adequate protection.

4.3.6 Remote RRU401.5 Programming Procedure for RSRG Autonomous Runway Guard Light

IR Remote Configuration procedure if the remote stops working or Anderic RRU401.5 batteries are

Figure 6: Remote Configuration



1. Press and hold the component key TV (top-left) for 3 seconds until the TV key light remains on. Release the TV key. The illuminated ON/OFF key turns on and remains on. During the programming mode, not pressing any button for 20 seconds will cause the remote to exit the programming mode.
2. Use the number keys (0-9) on the keypad to enter 2001.
 - a. If valid - the Mode key light will go out directly.
 - b. If invalid - the Mode key will blink 3 times quickly and go out. Please return to step 1.
3. Turn on the the AXON RSRG Runway Guard Light you want to change flash program.
4. Check if the keys can control the RSRG light. (Position remote close and aim the remote into the side 2 optical sensor window)
 - a. Ensure "TV" mode is enabled (press and release "TV" button).
 - b. Press and release "0" button (for initial flash "ON").
 - c. Press and release "cc" button.
 - d. Verify the fixture flashes 4 times. (unit is configured for initial flash "ON".)



Note

The IR Remote is only used in unmonitored applications in which no Remote Control device is present. Prior to using the IR Remote, the fixture must be energized at any brightness step and flashing.

5. Press and release the remote TV key.
6. Point the IR Remote at the L-852G(L) side 2 optical sensor window (prism). The IR Remote should be held approximately 0.5" (13 mm) from the window at an angle of approximately 45° from the pavement surface.

7. Press and release IR Remote keys according to the following table.

Setting	First Key	Second Key	Notes
Initial Flash ON	0	"CC"	The RSRG light turns on, then turns off.
Initial Flash OFF	2	"CC"	The RSRG light turns off, then turns on.
ON alternative	1	"CC"	If a CCR only powers a single RGL bar, the L-852G(L) fixtures within the bar shall be configured "ON (RSRG1XXX1NY1SXX1) Initial flash ON) next OFF (RSRG1XXX1NY0SXX1) Initial flash OFF) next ON ((RSRG1XXX1NY1SXX1)Initial flash ON) ... etc." If a CCR powers multiple RGL bars, it is recommended that approximately half of the continuous bars shall be configured "ON next OFF" and the rest use the "alternative ON next alternative OFF" settings. The alternative settings incorporate a small time delay (when compared to the ON or OFF setting). This small time delay on half of the RGL bars evens out the load on a CCR, reducing CCR output current fluctuations.
OFF alternative	3	"CC" (old remote was "OK" button)	

8. The First Key is pressed followed by the "CC" key within 2 seconds.



Note

The system will respond to an INQUIRY to the programmed setting as follows:

- Programmed for '0', unit will flash 4 times to confirm setting.
- Programmed for '2', unit will flash 2 times to confirm setting.

9. The L-852G(L) should start to flash as commanded. The setting is kept in its volatile memory.



Note

The programming procedure can be repeated if necessary.

4.3.7 Testing for Leaks

To test for leaks, perform the following procedure:

- See [Figure 12](#) Remove pressure relief screw.
- See [Figure 17](#) Screw pressure test fitting into the pressure relief port (the opening created when the pressure relief screw is removed). Screw fitting hand-tight.

4.3.8 Verify Input Requirements and Equipment Needed

The In-pavement light fixture is designed for connection to a 6.6A or 20A series lighting circuit via an L-830 (60 Hz) or L-831 (50 Hz) isolation transformer.

Make sure you have the necessary tools and materials ready for installation (not supplied). Also consider other tools that might be needed based on site-specific conditions.

4.3.9 Inspect on Delivery

- Inspect all packings for visible damage.
- Open every damaged box and inspect the contents for damage.
- Immediately fill a claim form with the carrier if any fixture is damaged.
- Store the fixture in its original packing in a protected area.



Note

If damage to any equipment is noted, file a claim form with the carrier immediately.



WARNING

Do not damage the cable insulation.



CAUTION

Do not unpack the fixture before it is at the installation site to avoid damage due to transportation and handling.

4.3.10 Installation and Removal of the 8- & 12-inch Light Fixture



WARNING

Read the instructions in their entirety before starting installation.

This section provides instructions for installing the in-pavement lights. Refer to airport project plans and specifications for specific installation instructions. The installation must conform to the applicable sections of the National Electric Code and local codes.

Install the light fixture in a base, class 1, direct-mounted fixtures

Figure 7: 2-Inch Shallow Base, Class 1, Direct-Mounted Fixtures

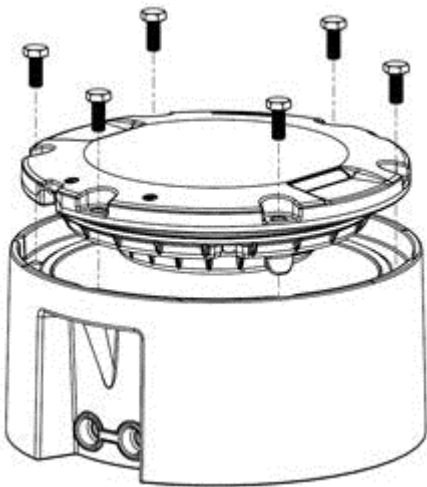

1. Carefully clean all contact surfaces of the light fixture and the base.
2. Put the O-ring gasket in the gasket track on the base.



Note

Not for class 2.

3. Connect the connector(s) of the light fixture to the base supply cable(s). Check that the sides 1 and 2 are connected to corresponding circuit if two connectors are used.
4. Align the position of the light fixture in one line with the holes.
5. Mount light fixture to the base.



Note

Make sure the secondary cables are below the light and not quenched between the light and base.

6. For an installation on bases, use a torque limiting box spanner of 16/17 mm, install and tighten the two, four or six fixing bolts (version-dependent) or nuts to a torque value according to specification, see [INTEROPERABILITY](#). For other base manufacturers, refer to their specifications.



Note

Do not use high speed for tightening, the recommended speed is 10 - 40 rpm. Do not use an impact driver/wrench.

7. After installation, make sure that each light fixture functions properly.
8. In order to bond the light fixture to ground, use a ground lug or grounding screw (torque 2.5 Nm) to attach the braided ground strap or ground wire to the grounding point on the light fixture. The grounding point is indicated by a grounding symbol and located on the bottom side.

Remove the fitting from the base



CAUTION

Fall- and trip hazard! When a light fixture has been removed, the base must be fitted with a cover designed for this purpose or with a spare light fixture.

1. Remove the light fixture from the base using two large flat blade screwdrivers.
 2. Disconnect the secondary supply connector.
 3. Remove and check the gasket (O-ring or labyrinth).
-



Note

It is recommended to change the gasket, lock nuts or bolts each time the light fixture is removed or dismounted from the base. For more information, see [INTEROPERABILITY](#).



CAUTION

Use of incorrect combination of gaskets, bolts and nuts can create severe damages to the product installation and create multiple safety risks.

Make sure to know what base the light fixture will be installed in, in order to choose the correct gasket, bolts and nuts. Failure to follow these cautions can result in equipment damage or aircraft FOD. For more information, see [INTEROPERABILITY](#).

4.4 Toe-In

Toe-in of light fixtures can be achieved in two ways:

1. By installing the light fixture in runway parallel bases and use light fixtures with built in toe-in.
2. By installing the light fixture in bases installed at an angle relative the runway/taxiway and use light fixtures with no built in toe-in.

If bases which are installed at an angle, provided that they are installed at the correct angle, light fixtures with no toe-in are to be used.

This section only regards the case where light fixtures are installed in runway parallel base, i.e. where no toe-in is achieved by angled bases.

There are three major categories regarding the toe-in in light fixtures:

Light fixtures - No Toe-in	Light fixtures have no toe-in - the light beam is straight.
Light fixtures - Toed Right	Light fixtures have an optical assembly that toes the light beam to the right at a defined angle.
Light fixtures - Toed Left	Light fixtures have an optical assembly that toes the light beam to the left at a defined angle.

Figure 8: Toe-In

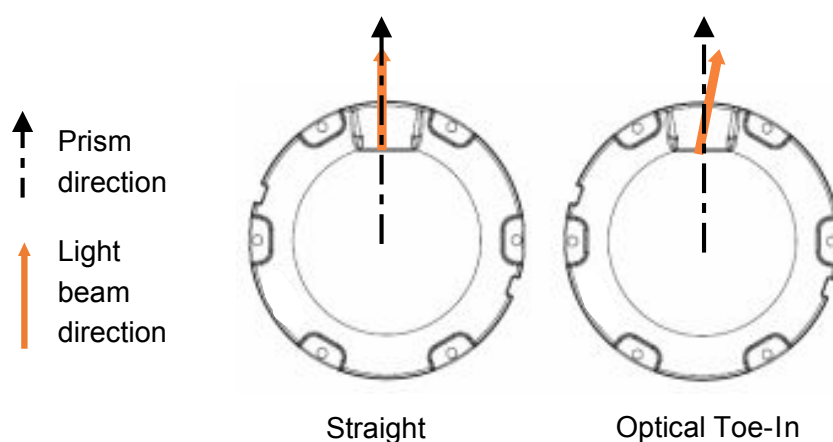

The table below shows a summary of the light fixture types and their toe-in properties.

Light fixtures	Toe-in options	Toe-in type
ICAO Runway Threshold, Threshold/End, (RT)	Straight or Toe-in ± 3.5	Optical
ICAO Approach Centerline / Crossbar	Straight	Optical
ICAO Approach Siderow	Straight	Optical
ICAO Approach Siderow Flash	Straight	Optical
ICAO Runway End	Straight	Optical
ICAO Runway Wingbar	Straight	Optical







4.5 Light Emission Directions

4.5.1 Definition of Light Emission Directions

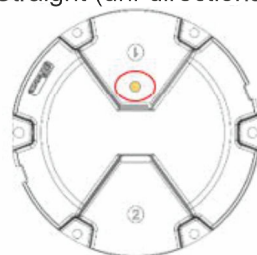
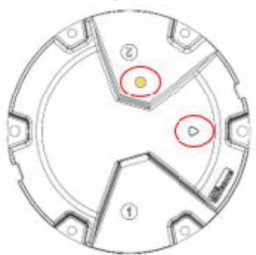
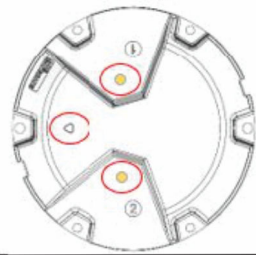
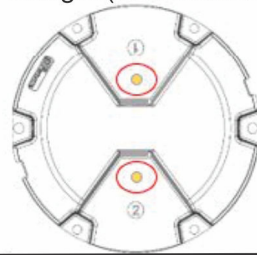
Light fixtures that have a toe-in are marked with an arrow to ensure a correct installation with regard towards the toe-in. The light fixtures should be installed with the arrow pointing towards the centerline.

The color of the emitted light is indicated with a painted dot on the top cover in front of the prism.

Figure 9: Light Emissions Direction

<p>Left toe</p> 	<p>Straight (uni-directional)</p> 	<p>Right toe</p> 
<p>Curved</p> 	<p>Straight (bi-directional)</p> 	
<p>Color</p>	<p>Color code</p>	
<p>W</p>	<p>White</p>	
<p>Y</p>	<p>Yellow</p>	
<p>G or F</p>	<p>Green</p>	
<p>R</p>	<p>Red</p>	
<p>B</p>	<p>Blue</p>	
<p>A</p>	<p>Amber - light orange</p>	

5.0 Maintenance

This section describes different steps for maintenance of the light fixture.

Before you start, make sure you have read and understand [Safety instructions](#).

Find out the location of the light unit that needs maintenance. If the purpose is to replace an existing light unit with new one, make sure that corresponding unit is available. Find the type information on the identification tag with details of name.

Spare parts are available, if required. For more information, see www.adbsafegate.com and the Spare Parts List document, or contact ADB SAFEGATE for assistance.



CAUTION

Use of incorrect combination of gaskets, bolts and nuts can create severe damages to the product installation and create multiple safety risks.

You need to know what base the light fixture will be installed in, in order to choose the correct gasket, bolts and nuts. Failure to follow these cautions can result in equipment damage or aircraft FOD.



CAUTION

When a light fixture has been removed from its base, the base must be either fitted with a cover or a spare light fixture put in its place. It is recommended that only authorized personnel disassemble fittings with prior agreement from ADB SAFEGATE.

5.1 Basic Maintenance Program

It is important to understand that even though a LED fixture requires substantially lower maintenance in regard to the replacement of the light bulbs, some parts of the light fixture remain the same and still require the same level of maintenance (prisms, top cover, bolts).

There are recommended maintenance tasks to ensure that the equipment is in correct operating condition.

Maintenance tasks

Weekly	<ul style="list-style-type: none"> • Visual inspection of the light fixture. • Removal of dust from external surfaces of the light fixture.
Monthly	<ul style="list-style-type: none"> • Check optical window for cleanliness, mechanical damage or moisture/condensation on the inside of the prism • Check for improper torque on mounting bolts. Re-torque if needed.
Yearly	<ul style="list-style-type: none"> • Detailed inspection of the light fixture • Check of the body resistance, check for mechanical damage (for example cracks around the prism windows). • Clean optical windows
Bi-yearly	<ul style="list-style-type: none"> • Check for presence of water in mounting support by unscrewing and lifting light fixture from base and check for water ingress and corrosion. Replace gasket between light fixture and base.
After snow removal	<ul style="list-style-type: none"> • Check for damaged light fixtures. Any damaged light fixtures should be replaced and brought in and properly investigated and repaired.

A daily function check is referred to in the document:

ICAO, Airport Services Manual Part 9, Airport Maintenance Practice and FAA AC 150/5340-26A, Maintenance of airport visual aids facilities.

Any issues found during maintenance tasks should be corrected accordingly and properly documented.

A proper asset management system such as ADB Safegate's ALIS can help to store/document data and can provide valuable information on local presiding conditions for preventive maintenance planning. This can then be used to minimize the need for reactive maintenance.



ALIS, ADB Safegate's new digital asset tracking, inspection and service solution, helps airports easily register airside assets, electronically schedule and track maintenance, and record maintenance and inspection tasks in compliance with ICAO and FAA standards.

Visit alis.adbsg.com.

5.2 Recommended Maintenance Program for optimal Service Life

Service Life and Inspection intervals

All products have an expected service life. Service life is the lifetime of the product and reaching the end means that it is no longer serviceable and should be replaced.

There are several key external factors that influences the service life of a product.

- Aircraft traffic movements
- Location on the airfield
- Maintenance
- Chemical usage

Air Traffic Movements (ATM)

The expected lifetime of a light fixture will be highly impacted by the traffic volume and the number of aircraft that are mechanically putting stress on the light fixtures. Airports with a higher traffic volume will have a light fixture with a shorter expected lifetime than an airport with a lower traffic volume.

The ATM can be divided into three categories for the recommendation of inspections as well as for the expected lifetime of a light fixture ^{*}.

- 0-100k movements/ year
- 100k-200k movements/ year
- >200k movements/ year

Location on the airfield

The expected lifetime of a light fixture is highly dependent on the location where it is installed on an airfield. Three different areas have been defined by color categorization that are exposed to different degree of mechanical impact. These three categories are used as a basis for the recommendation of inspections as well as for the expected lifetime of a light fixture.

- **RED** – Touch Down Area defined as 6m either side of the runway centerline for a distance starting 50m before the TDZ markings and extending to 200m beyond the TDZ markings as seen from the landing direction.
- **RED** – Rapid Exit Taxiway centerline lights from the runway centerline to 50m beyond the edge of the runway.
- **Amber** – All runway areas outside of the red areas. Also includes taxiway intersections for which more than 50% of the aircraft traffic turn more than 45 degrees.
- **Green** – Areas outside Red and Amber areas



NOTICE

It is recommended that there is a reliable means of recording the location history of fittings (similar to ADB Safegate ALIS) to ensure that the maximum duration in critical areas (RED) of the runway are not exceeded.

^{*} Based on ADB SAFEGATE's field experience and investigation made together with an independent consultant and airport.

Preventive maintenance

Preventive maintenance and inspections will help to prolong the service life of a light fixture. By finding issues (e. g., bad gaskets or broken prisms) at an early stage you can mitigate and fix issue before they cause more damage and reduce the cost of the repair. You can also increase the service life of a light fixture by rotating the installation location of light fixtures in critical areas.

Regular inspections and well-defined preventive maintenance planning will help to reduce the overall maintenance cost and reduce downtime from reactive maintenance tasks.

Figure 10: Preventive Maintenance

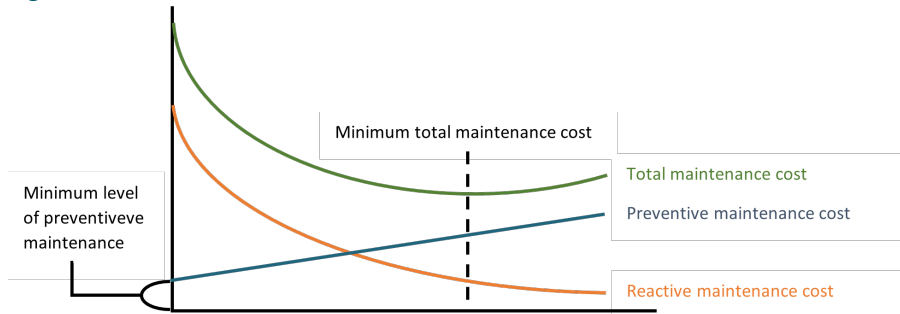

5.2.1 Recommendation

Based on the air traffic volume and location on the airfield, a matrix was created for recommended inspection intervals.

Figure 11: Visual Inspection Interval

Location	RED	Amber	Green
ATM			
0-100k movements	2 Months 1 Year	6 Months 3 Years	1 Year 3 Years
100k-200k movements	2 Months 1 Year	4 Months 2 Years	1 Year 3 Years
Above 200k movements	1 Months 6 Months	2 Months 1 Year	1 Year 3 Years

Inspection interval

Visual inspection: Visually inspect the light fixture and make sure that

- Prism is clean and no cracks are visible
- Gaskets are ok and are not deteriorating
- No moisture or condensation can be seen on the inside of the prism
- Corrosion on top cover, around the prism and bolts.
- Torquing of nuts/bolts are according to specification

Detailed Inspection: Includes visual inspection tasks and additionally the following tasks

- Unbolt the light fixture and lift it from the base for the detailed inspection
- Check for water ingress (watertight installation) and corrosion on light fixture and base (especially around the mating surfaces)
- For deep base installation (L-868) check for water ingress, if more than 6 inches please have it removed.
- Inspect light and base for damage
- Replace gasket between light fixture and base

NOTICE

We recommend any maintenance work that requires the light fixture to be opened to be done back in the dedicated maintenance area.

- We recommend that inspection intervals are halved for aging units that have reached more than 75 % of their expected lifetime.
- We recommend that AGL in critical areas are rotated.
- To achieve a proper location rotation and individual asset, data needs to be recorded.
- To relax the recommended frequencies of some maintenance tasks i.e. torque management, data is needed for justification.
- Policies have a direct link with the age of the AGL and should also be tracked and recorded.

Below is the recommended service life. With a proper asset management (ALIS or similar) and data capturing strategy, the below guidelines could be extended or shortened as deemed necessary via presiding local conditions.

Expected service life (only critical areas defined)

• RED Zone -, ATM < 100k	Service Life 15 years
• RED Zone -, ATM > 100k < 200K	Service Life 10 years
• RED Zone -, ATM > 200k	Service Life 7 years



Note

Contact to your local sales representative if you have any questions or would require some assistance to go through local conditions and see how we can help establish a well-defined maintenance planning to optimize the expected service life of your investment.

5.3 Workshop Maintenance



CAUTION

Before you start, make sure you have read and understand [Safety instructions](#).



Note

A compressor, or a manual car tire pump, equipped with a manometer is required to check the light fixture for water-tightness.

Design may differ from picture depending on application. Please follow described work flow and torque level specified as they are generic.

The workshop maintenance refers to following:

1. Open a light fixture
2. Close a light fixture
3. Replace the power wire harness
4. Replace the light engine assembly
5. Replace the prism
6. Reset the top cover assembly
7. Replace the bottom pan assembly
8. Replace the secondary cable
9. Reset the fail-open converter
10. Check the light fixture for water-tightness

5.3.1 Opening a Light Fixture — disconnecting the Bottom Pan from the Top Cover

Tools to be used:

- Screwdriver or variable-speed torque drill driver with T25 Torx bit for 8-inch and T30 Torx bit for 12-inch.



NOTICE

Do not use an Impact driver.

- Flat-head screwdriver
1. Place the light fixture upside down.
 2. Loosen the Pressure Release Screw.

Figure 12: Loosening Pressure Release Screw

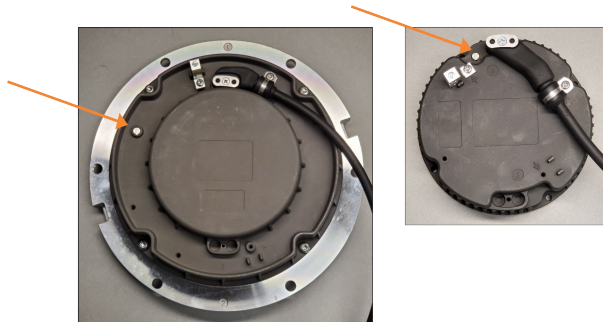

3. Unscrew the fixation screws (4 pcs, keeping the bottom cover attached to top cover).
Make sure you **dispose the old screws** and use new screws.
4. Lift the Bottom Pan without damaging the connecting wires.



CAUTION

Make sure you do not damage the cables when opening the light fixture.

5. Disconnect the wires:
 - a. Pull carefully to disconnect the wires between the converter and the light engine.
 - b. Pull carefully to disconnect the wires between the converter and the heater kit(s), if the heater kit is in place.
6. Remove the gasket between the Top Cover Assembly and the Inner Pan Assembly.
Make sure you **dispose the old gasket** and use a new gasket.

5.3.2 Close a Light Fixture — connect the Bottom Pan to the Top Cover

Tools to be used:

- Screwdriver or variable-speed torque drill driver with T25 Torx bit for 8-inch and T30 Torx bit for 12-inch.
- Flat-head screwdriver.

1. Clean all the contact surfaces of the light fixture and of the housing carefully.
2. Press the gasket (located between top cover and inner pan) into the O-ring Groove.
Make sure the gasket placed correctly.

Important

The O-ring Gasket must always be changed when the fixture is being disassembled.

Figure 13: Gasket Placement

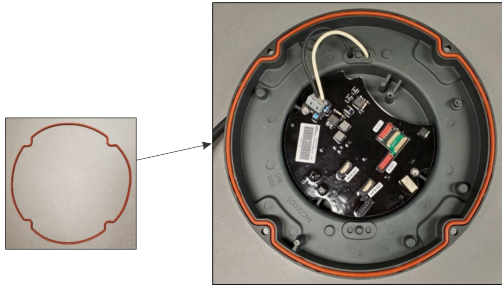

3. Connect the wires:
 - a. Press carefully to connect the wires lead in from the light engine on the converter.
 - b. Press carefully to connect the wires lead in from the light engine on the converter, if the heater kit is in place.
4. Put the Top Cover onto the Bottom Pan.
Make sure the poke-yoke (alignment pin) is in the placed correctly.

Important

Do not pinch the wires or the gasket

Figure 14: Top Cover Placement



5. Put the light fixture on a surface with the top cover facing down.

6. Torque:

- a. Use new fixation screws to torque in star pattern at 53 in-lbs (6 Nm) for 12-inch light or 31 in-lbs (3.5 Nm) for 8-inch lights.
- b. Retorque the screws in star pattern at 53 in-lbs (6 Nm) for 12-inch light or 31 in-lbs (3.5 Nm) for 8-inch lights.

Figure 15: Star Pattern

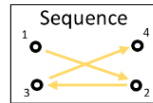

7. Follow the water-tightness test procedure.



Note

Refer to the [Check the Light Fixture for Water-tightness](#) section.

5.3.3 Replace the Wire Harnesses

Tools to be used:

- Screwdriver or variable-speed torque drill driver with T20 Torx bit.

1. Open the light.
-



Note

Refer to the [Opening a Light Fixture — disconnecting the Bottom Pan from the Top Cover](#) section.

2. Disconnect the old wire harnesses.
Make sure you **dispose the old wire harnesses** and use new wire harnesses.

Figure 16: Dispose Old Wire Harnesses

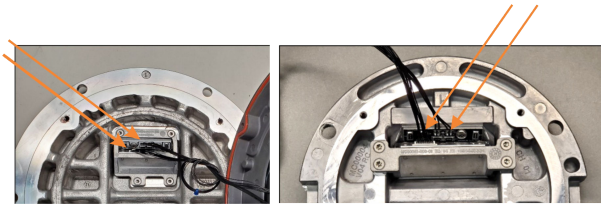

3. Connect the new wire harnesses.
Make sure the direction of the connector is correct to avoid damaged pins.
 4. Close the light.
-



Note

Refer to the [Close a Light Fixture — connect the Bottom Pan to the Top Cover](#) section.

5.3.4 Replace the Light Engine Assembly

Tools to be used:

- Screwdriver or variable-speed torque drill driver with T20 Torx bit.

1. Open the light.



Note

Refer to the [Opening a Light Fixture — disconnecting the Bottom Pan from the Top Cover](#) section.

2. Remove the Light engine(s) (4 pieces M4 screws per light engine assembly).
 Make sure you **dispose the old screws, light engine(s), and wire harness(es)**, and the new material.

Figure 17: Removal of Light Engine(s) Assembly

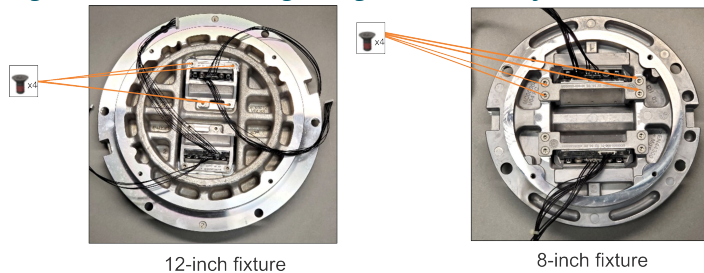

3. Mount the new light engine(s) with the wire harnesses attached.
 4. Use new screws to attach the light engine in star pattern at 26 inch-pound (3.0 Nm).

Figure 18: Star Pattern

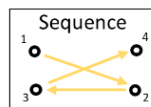

5. Close the light.



Note

Refer to the [Close a Light Fixture — connect the Bottom Pan to the Top Cover](#) section.

5.3.5 Replace the Prism and its Gasket

Tools to be used:

- Screwdriver or variable-speed torque drill driver with T20 Torx bit.

1. Open the light.



Note

Refer to the [Opening a Light Fixture — disconnecting the Bottom Pan from the Top Cover](#) section.

2. Remove the Light engine assembly (4 M4 screws per light engine assembly).

Make sure you **dispose the old screws** and use new screws.

Figure 19: Removal of Light Engine(s) Assembly

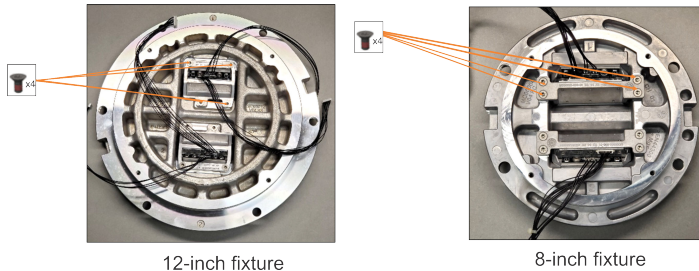

3. Remove the Prism-keeper Plate and Prism-protection Gap Pad (4xM4x10 and 2xM4x8).

Figure 20: Removal of the Prism-Keeper Plate and Prism-Protection Gap Pad

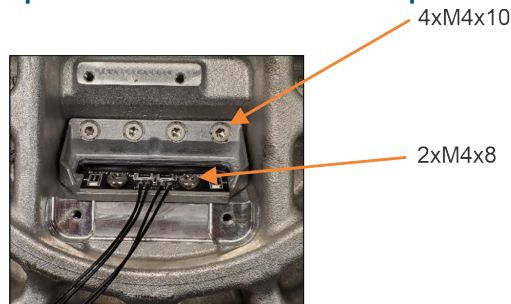

4. Remove the prism the prism gasket by pushing from outside.
Make sure you **dispose the old prisms and gaskets** and the new material.
 5. Install the new sock seal and mount the new prism gasket into the top cover.
-

Important

Make sure the wider slant is oriented towards the center of the fixture.

6. Apply some glass cleaner on the outside of sock seal.
7. Press the prism assembly into the window of the top cover with a rocking motion.
8. Use pressure to set the prism into the top cover.
9. Clean the prism with a clean rag or a wipe.

10. Place the Prism Protection Gap Pad on top of the prism.

Figure 21: Prism Protection Gap Pad Placement

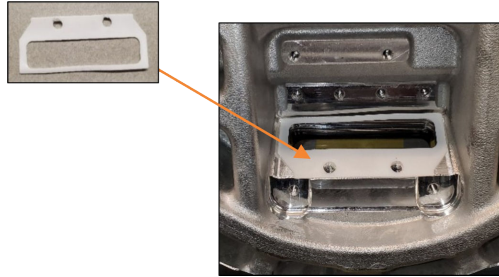

11. Install the Prism-keeper Plate into the top cover with 2 M4x10 screws (26 in-lbs/3 Nm) to the “top” of the Prism-keeper Plate.

The heater must be installed under the screws, if the heater is included.

Figure 22: Prism-Keeper Plate Installation into the Top Cover

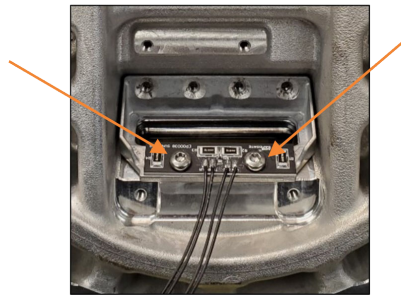

12. Finish the mounting procedure for the Prism-keeper Plate with 4 M4x8 screws at 26 in-lbs (3 Nm) to the “bottom” of the prism keeper plate.

Make sure you tighten the screws in the correct order (refer to the image below).

Figure 23: Mounting Procedure

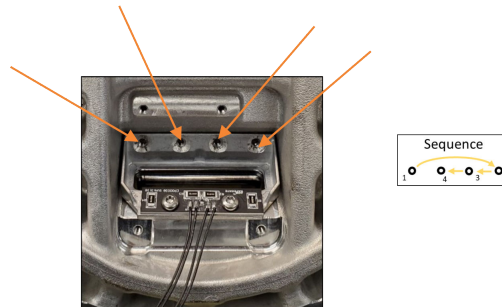

13. Mount the Light Engine Assembly onto the top cover with 4 new M4x10 screws at 26 in-lbs (3 Nm).

Important

Make sure you mount the Light Engine Assembly on the correct side of the top cover, with the correct color and toe-in (refer to the image below).

Figure 24: Light Engine Assembly Mounting Procedure

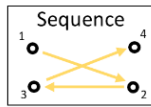
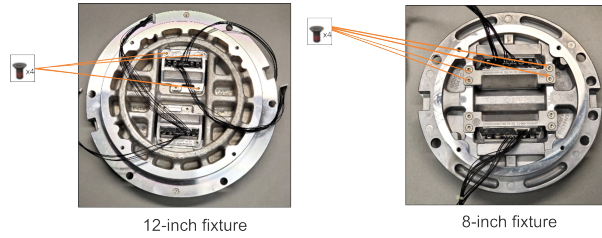

14. Close the light.



Note

Refer to the [Close a Light Fixture — connect the Bottom Pan to the Top Cover](#) section.

5.3.6 Replace the Top Cover Assembly

Tools to be used:

- Screwdriver or variable-speed torque drill driver with T25 Torx bit for 8-inch and T30 Torx bit for 12-inch.
- Flat-head screwdriver

1. Open the light.

Note Refer to the [Opening a Light Fixture — disconnecting the Bottom Pan from the Top Cover](#) section.

2. Remove the Light Engine(s) (4 M4 screws per light engine assembly.)

Make sure you **dispose the old screws and the old top cover** and use the new material.

Figure 25: Dispose Old Screws and Old Top Cover

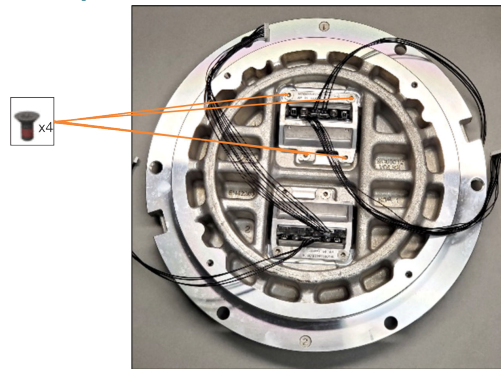

3. Replace the old top cover with new top cover assembly.

4. Mount the light engine(s) into the new top cover assembly.

5. Use 4 new M4x10 screws to attach the light engine in star pattern at 26 in-lbs (3 Nm).

Figure 26: Star Pattern

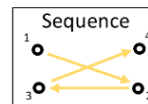

6. Close the light.

Note Refer to the [Close a Light Fixture — connect the Bottom Pan to the Top Cover](#) section.

5.3.7 Replace the Bottom Cover Assembly

Tools to be used:

- Screwdriver or variable-speed torque drill driver with T25 Torx bit for 8-inch and T30 Torx bit for 12-inch.
- Flat-head screwdriver

1. Open the light.



Note

Refer to the [Opening a Light Fixture — disconnecting the Bottom Pan from the Top Cover](#) section.

Make sure you **dispose the old bottom cover assembly** and use the new assembly.

2. Close the light.



Note

Refer to the [Close a Light Fixture — connect the Bottom Pan to the Top Cover](#) section.

5.3.8 Replace the secondary Cable — SJO cord set

Figure 27: Secondary Cable Replacement



Tools to be used:

- Screwdriver or variable-speed torque drill driver with T20 Torx bit
- Flat-head screwdriver
- Small flat head screwdriver or Insert Tool, Part No : 236-332



1. Open the light.



Note

Refer to the [Opening a Light Fixture — disconnecting the Bottom Pan from the Top Cover](#) section.

2. Disconnect the cable:

- Disconnect the secondary cable from the converter by placing a small flat-head screwdriver or insert tool into the opening located at the other side of the secondary wire, and
- Release the cable by prying the screwdriver or Insert Tool on the cable release opening.

Figure 28: Disconnecting Secondary Cable

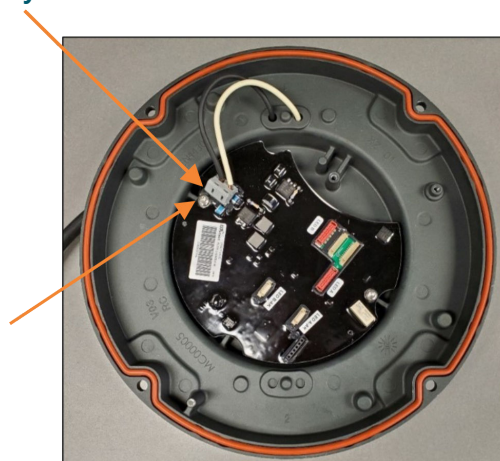

3. 4. Unscrew the Cord-set-retainer Disc Bolt.

Make sure you **dispose the old bolt and Cord-set-retainer disc** and use the new material.

Figure 29: Dispose Old Bolt and Cord-Set-Retainer Disc

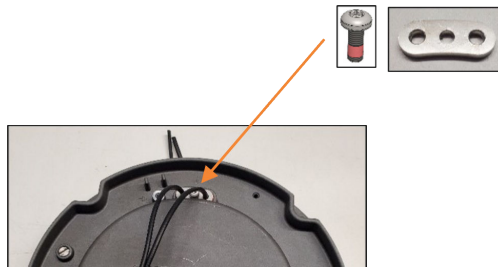

4. Unscrew the cable clamp.

Make sure you dispose **the old bolt, washer and lock washer** and use the new material.

Figure 30: Dispose Old Bolt, Washer and Lock Washer



5. Remove the secondary cable.

Make sure you dispose **the old secondary cable** and use the new secondary cable.

6. Remove the old cable gland gaskets.

7. Install the new cable gland gaskets.

Figure 31: New Cable Gland Gasket Installation

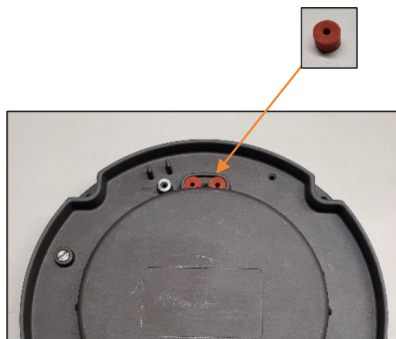

8. Install the new Cord-set-retainer Disc (M4x10) into the Bottom Cover.

Make sure the **Cord-set-retainer Disc** sits loosely in the Bottom Cover.

Figure 32: Loosen the Cord-Set-Retainer Disc in the Bottom Cover

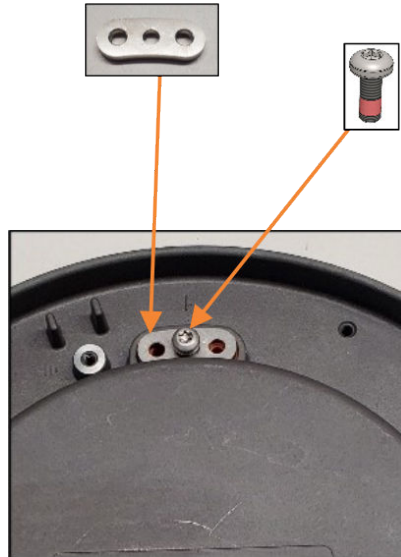

9. Installation:

- a. Install cord set into the Bottom Over using the cord set.
- b. Pull the cable through into the inside of the Bottom Cover.
Make sure the cable is on the inside of the Bottom Cover.
- c. Mount the Retainer Disc onto the cable.
- d. Tighten the screw at 26 in-lbs (3 Nm).
- e. Loop the clamp using a new screw, lockwasher and flatwasher.
- f. Tighten the new screw, lockwasher and flatwasher at 26 in-lbs (3 Nm).

Figure 33: Installation Steps Overview

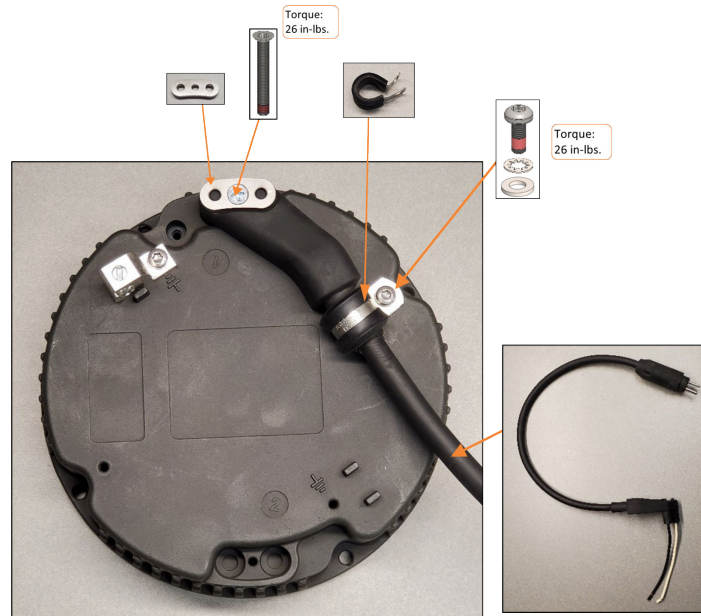

10. Locking:

- a. Lock the secondary cables leading to the converter by opening the cable holes prying a thin screwdriver or insert tool on the cable release opening and mounting the wires in place and
- b. Lock the cables by releasing screwdriver from the opening.

Figure 34: Locking Secondary Cables

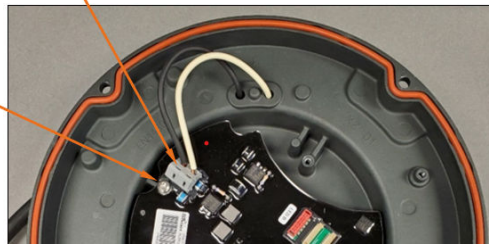

11. Close the light.



Note

Refer to the [Close a Light Fixture — connect the Bottom Pan to the Top Cover](#) section.

5.3.9 Replace the Secondary Cable — Style-6 Cord Set

Figure 35: Secondary Cable Replacement



Tools to be used:

- Screwdriver or variable-speed torque drill driver with T20 Torx bit
- Flat-head screwdriver
- Small flat head screwdriver or insert tool, part no : 236-332



1. Open the light.



Note

Refer to the [Opening a Light Fixture — disconnecting the Bottom Pan from the Top Cover](#) section.

2. Disconnect the cable:

- Disconnect the secondary cable from the converter by placing a small flat-head screwdriver or insert tool into the opening located at the other side of the secondary wire, and
- Release the cable by prying the screwdriver on the cable release opening.

Figure 36: Disconnecting secondary cable

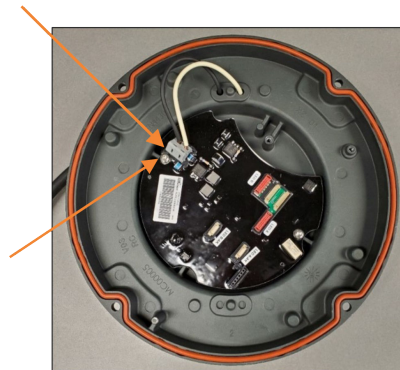

3. Cut the Wire Tie.

4. Remove the nylon hex nut.

Figure 37: Removal of nylon hex nut

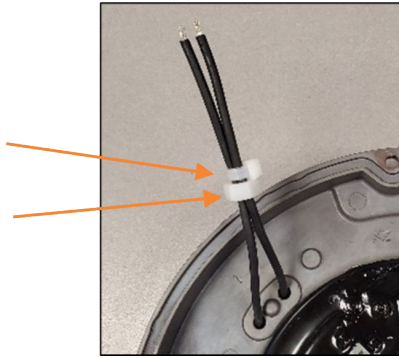

5. Unscrew the Cord-set-retainer Disc Bolt.

Make sure you **dispose the old bolt and Cord-set-retainer disc** and use the new material.

Figure 38: Dispose old bolt and cord-set-retainer disc

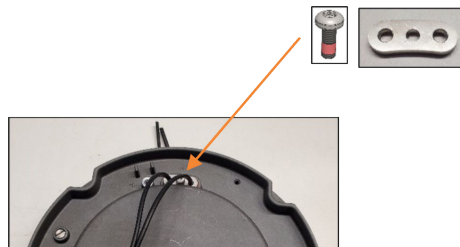

6. Remove the secondary cable.

Make sure you dispose **the old secondary cable** and use the new secondary cable.

7. Remove the old cable gland gaskets.

8. Install the new cable gland gaskets.

Figure 39: New cable gland gasket installation

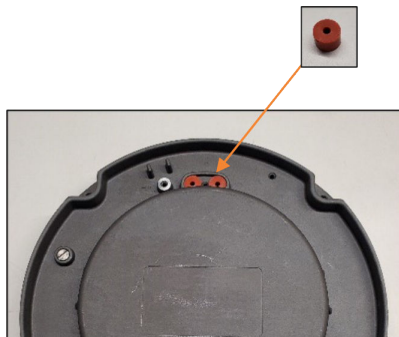

9. Install the new Cord-set-retainer Disc (M4x10) into the Bottom Cover.

Make sure the **Cord-set-retainer Disc** sits loosely in the Bottom Cover.

Figure 40: Loosen cord-set-retainer disc in the bottom cover

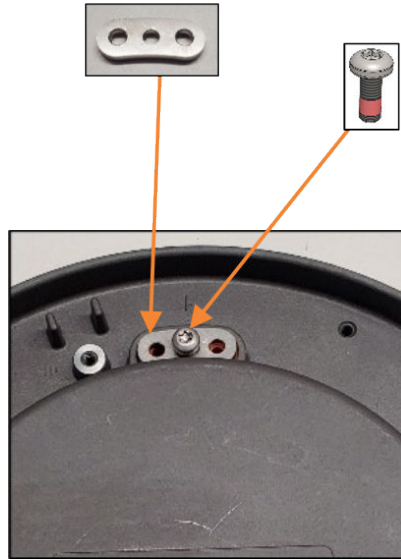

10. Installation:

- a. Pull the new secondary wires through the new Cord-set-retainer Disc Plate.
- b. Pull approximately 4 inches (100 mm) of the secondary cable through the Cord-set-retainer Disc Plate. Make sure the 4-inches of the cable are on the inside of the Bottom Cover.

Figure 41: Installation of secondary cable

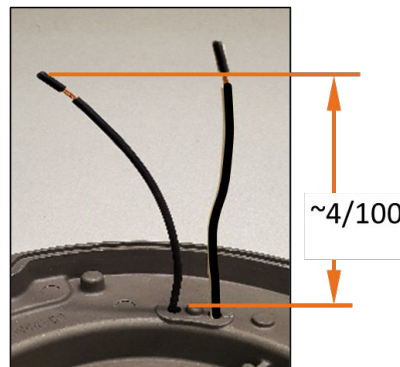

11. Place the new nylon hex nut into cord set.

12. Secure it tightly with a Wire Tie at a position of 2½ inches (64 mm) from the end of the cord set.

Figure 42: Secure nylon hex nut tightly with a wire tie

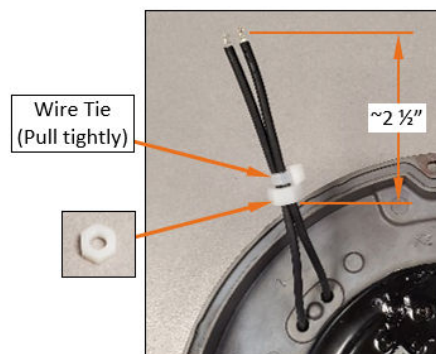

13. Tighten the new Cord-set-retainer Bolt at 26 in-lbs (3 Nm).

Figure 43: Tighten new cold-set-retainer bolt

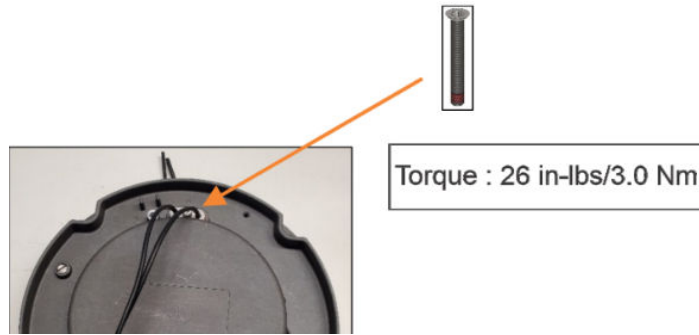

14. Locking:

- a. Lock the secondary cables leading to the converter by opening the cable holes prying a thin screwdriver or insert tool on the cable release opening and mounting the wires in place and
- b. Lock the cables by removing screwdriver or insert tool from the opening.

Figure 44: Locking secondary cables

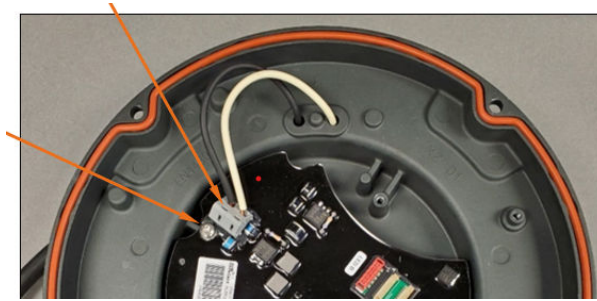

15. Close the light.



Note

Refer to the [Close a Light Fixture — connect the Bottom Pan to the Top Cover](#) section.

5.3.10 Replace the Secondary Cable — French 3-Pin Cord Set

Tools to be used:

- Screwdriver or variable-speed torque drill driver with T20 Torx bit.
- Flat-head screwdriver
- Small flat head screwdriver or insert tool, part no: 236-332



1. Open the light.



Note

Refer to the [Opening a Light Fixture — disconnecting the Bottom Pan from the Top Cover](#) section.

2. Disconnect the cable:

- Disconnect the secondary cable from the converter by placing a small flat-head screwdriver or insert tool into the opening located at the other side of the secondary wire, and
- Release the cable by prying the screwdriver or insert tool on the cable release opening.

Figure 45: Disconnecting Secondary Cable

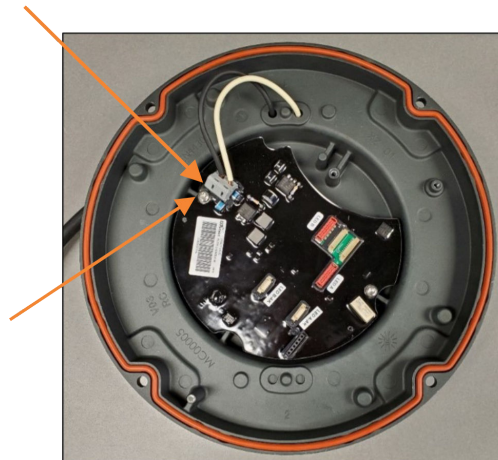

3. Cut the Wire Tie.

4. Remove the nylon hex nut.

Figure 46: Removal of Nylon Hex Nut

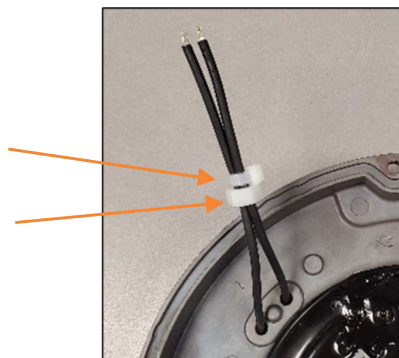

5. Unscrew the Cord-set-retainer Disc Bolt.

Make sure you **dispose the old bolt and cord-set-retainer disc** and use the new material.

Figure 47: Dispose of Old Bolt and Cord-Set-Retainer-Disc

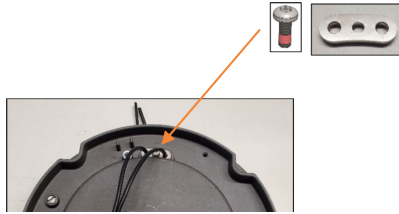

6. Disconnect the ground wire of the cord set from the Bottom Cover.
Make sure you **dispose the old bolt and washer** and use the new material.

Figure 48: Dispose of Old Bolt and Washer

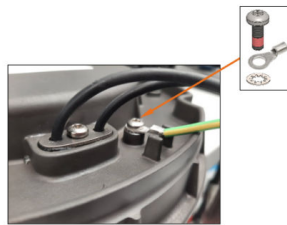

7. Remove the secondary cable.
Make sure you dispose **the old secondary cable** and use the new secondary cable.
8. Remove the old cable gland gaskets.
9. Install the new cable gland gaskets.

Figure 49: Installation of New Cable Gland Gasket

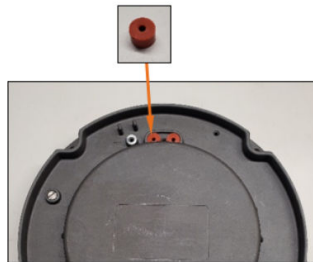

10. Install the new Cord-set-retainer Disc (M4x10) into the Bottom Cover.

Make sure the **Cord-set-retainer Disc** sits loosely in the Bottom Cover.

Figure 50: Loosen Cord-Set-Retainer-Disc in the Bottom Cover

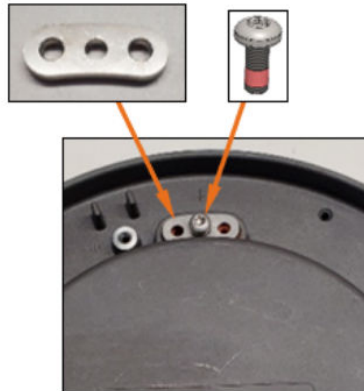

11. Installation:

- a. Pull the new secondary wires through the new cord-set-retainer-disc plate.
- b. Pull approximately 4 inches (100 mm) of the secondary cable through the cord-set-retainer-disc plate. Make sure the 4-inches of the cable are on the inside of the bottom cover.

Figure 51: Installation of New Secondary Wires

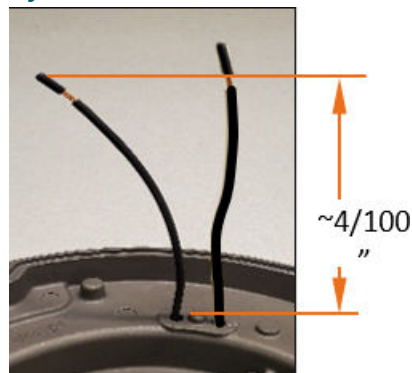

12. Place the new nylon hex nut into cord set.

13. Secure it tightly with a Wire Tie at a position of 2½ inches (64 mm) from the end of the cord set.

Figure 52: Securing Nylon Hex Nut Tightly with a Wire Tie

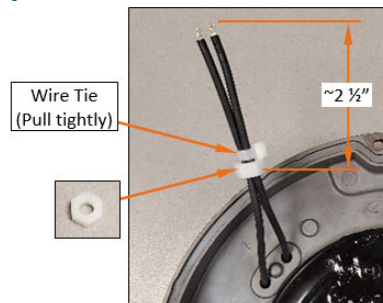

14. Tighten the new Cord-set-retainer Bolt at 26 in-lbs (3 Nm).

Figure 53: Tighten New Cord-Set-Retainer Bolt

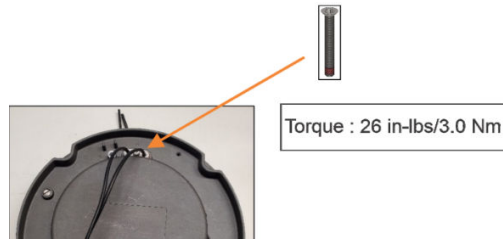

15. Connect the ground wire of the cord set to the Bottom Cover using the bolt and the washer.

16. Tighten the bolt at 26 in-lbs (3.0 Nm).

Figure 54: Tighten Bolt

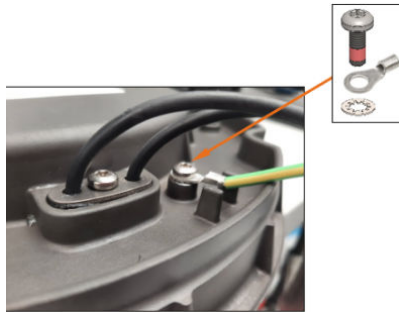

17. Locking:

- Lock the secondary cables leading to the converter by opening the cable holes prying a thin screwdriver or insert tool on the cable release opening and mounting the wires in place and
- Lock the cables by removing screwdriver or insert tool from the opening.

Figure 55: Locking Secondary Cables



18. Close the light.



Note

Refer to the [Close a Light Fixture — connect the Bottom Pan to the Top Cover](#) section.

5.3.11 Reset the Fail-Open Converter

Parts

- Fuse resistor spare part kit: 6132.00.250 (20 pcs)

Info

- Converter with 1 connector have 2 fuse resistors
- Converter with 2 connectors have 4 fuse resistors

Reset/Replace the Fuse Resistors

1. Disconnect and disassemble the light fixture.
2. Locate the fuse resistors.



Note

Refer to [Figure 56](#) and [Figure 57](#) figures.

Refer to Figure.

Figure 56: Fail-Open 1-Con

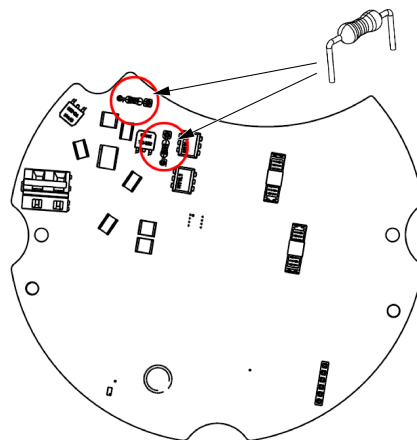
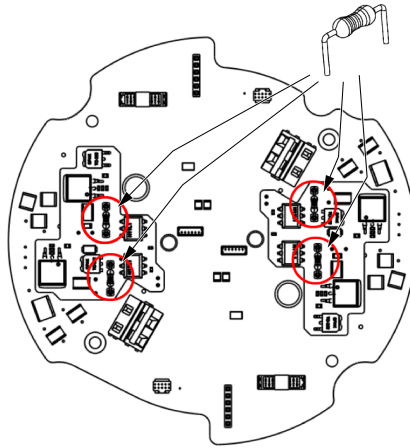

Figure 57: Fail-Open 2-Con



Figures 1 and 2

3. Remove the fuse resistors by pulling away from the converter.
 - a. For converters with 1 connector, always replace both fuse resistors at the same time.
 - b. For converters with 2 connectors, always replace both fuse resistors related to the 1/2 channel that needs to be reset.Make sure you replace all 4 fuse resistors, if both 1 and 2 channel needs a reset.
4. Dispose the old fuse resistor.
5. Place the legs of the new fuse resistors in the sockets.
6. Assemble the light fixture and perform a functional test.

5.3.12 Check the Light Fixture for Water-tightness

Tools to be used:

- Flat head screwdriver
- For water tight testing, pressure test fitting tool to be used : 44A6104/A

Execute the following procedure to test for leaks:

1. Remove the pressure-release screw and discard.
Refer to the image below.

Figure 58: Removal of Pressure-Release Screw

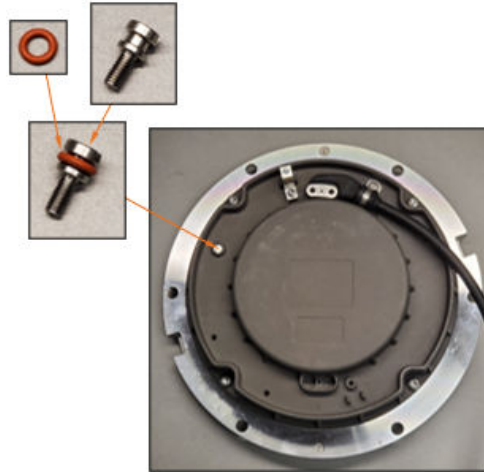

2. Screw the pressure test fitting to the Pressure-relief Port.



NOTICE

The Pressure-relief Port is the opening you created when the pressure release screw was removed.

3. Screw the fitting hand-tight.

Figure 59: Screw the Fitting Hand-Tight

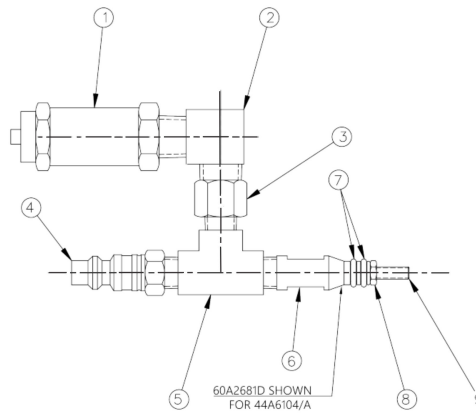

Call-out	Description
1	Pop — safety valve
2	90 deg., elbow, female X male, brass, 1/4"
3	Adapter, female — male, 1/4 x 1/8, brass
4	Sleeve — lock hose plug, 1/4" coupler
5	Tee, brass, 1/8
6	Pressure test fitting, body
7	O-ring, silicone, size 008, 1/16 W X 3/16
8	M4 Hex Jam nut, 18-8 SS
9	Pressure test fitting stud

4. Attach the shop airline to the Lock Hose Plug Sleeve (2).

5. Pressurize to 20 psi (130 kPa).

6. Submerge the pressure test fitting in a water tank.

7. Wait 3 minutes and check if air leaks out of the light.

If air leaks out of the light fixture (between the Bottom Cover and the top plate or between the prism and top plate or water-tightness valve and top plate), the light fixture is not watertight and must be repaired. Release the air from the light. Disassemble the light fixture and re-check the mating surfaces and gaskets. Assemble the light fixture and perform the water-tightness test again.

8. Depressurize and install a new pressure release screw (1) at 26 in-lbs (3 Nm), if the fixture is watertight.



DANGER

Never exceed a pressure of 22 psi (150 kPa) inside the light fixture. A higher pressure may cause injuries and damage the light.

6.0 Ordering Codes

6.1 Ordering Code LED L - 850A(L) Runway Centerline , L-850B(L) Touchdown Zone (ICAO & FAA)

Ordering Code

RS []

Application

RC= Runway Centerline, L-850A(L)
RZ= Touchdown Zone, L-850B(L)

Standards

1 = FAA/ICAO¹

Market Specific

0 = None
1 = Buy American Preference (BAP)^{2,3}
4 = German MIL 7-step FO¹⁰

Dimensions

1 = 8 inch (203 mm) diameter
2 = 12 inch (304 mm) diameter, 11.25 inch
BC (285 mm)
3 = 8 inch (203 mm) diameter, 4-bolt

Prism

S = Standard prism
R = Reinforced prism¹⁰

Beam Orientation

1 = Unidirectional
2 = Bidirectional

Toe-in

N = None ⁴
L = Left (only for RZ) ⁴
R = Right (only for RZ)⁴

Color – Side 1

W= White
R = Red

Color – Side 2

W= White
R = Red
N = None (Unidirectional app only)

Power and Monitoring

S = 2.8 A - 6.6 A, non-monitored — power only
M = 2.8 A - 6.6 A, Fail-open monitoring¹⁰
R = 2.8 A - 6.6 A EQ integrated LINC 360⁵

Cable and Connector⁶

1 = 1 x Style 6 2-pole plug, 2 individual wires¹⁰
2 = 1 x Style 1 2-pole plug, jacketed SO 2 core cable⁹
3 = 2 x Style 6 2-pole plug, 2 individual wires^{7,10}
4 = 2 x Style 1 2-pole plug, jacketed SO 2 core
cable^{7,9}
5 = 1 x Flat 3-pole plug, 3 individual wires¹⁰
6 = 2 x Flat 3-pole plug, 3 individual wires¹⁰

Options

0 = None⁸
1 = Arctic Kit⁸

Version

1 = Version 1

¹ Includes standards NATO, EASA, STAC, CAP 168, TP 312 and MOS 139.

² Required for FAA when using AIP funds.

³ If a 2-cord set fixture is required meeting BAP, Digit 13, "Power and Monitoring", must be M.

⁴ L and R designations are always in relationship to Side 1 only.

⁵ EQ light fixtures are only available as a one connector option.

⁶ All Style 1 corded fixtures will include a ground lug. All Style 6 and 3-pole corded fixtures will be provided with grounding screw(s).

⁷ Only available in Digit 13 options S and M and bi-directional configuration.

⁸ RC white/white application meets the heat rise requirements in Engineering Brief 67D, section 2.13.1, "Arctic Kit Testing Requirements" WITHOUT an arctic kit. We do not offer an arctic kit with this configuration as the additional heat would be detrimental to the life of the LEDs.

⁹ SO cord set option is not compatible with shallow bases. If required please contact ADB Safegate.

¹⁰ Not ETL-submitted or not applicable to FAA market.

6.2 Ordering Code LED L- 850C(L) Runway Edge 45 m (ICAO & FAA)

Ordering Code

Application

RE = L-850C(L)
Runway Edge ≤ 45 m width
runway

Standards

1 = FAA/ICAO¹

Market Specific

0 = None
1 = Buy American Preference (BAP)^{2,3}
4 = German MIL 7-step FO⁹

Dimensions

2 = 12 inch (305 mm) diameter, 11.25 inch
BC (285 mm)

Prism

S = Standard prism
R = Reinforced prism⁹

Beam Orientation

1 = Unidirectional
2 = Bidirectional

Toe-in

C = Curved (bidirectional application)
L = Left (unidirectional application)
R = Right (unidirectional application)

Color – Side 1 (Left)

W = White
Y = Yellow
R = Red
F = F-Green

Color – Side 2 (Right)

W = White
Y = Yellow
R = Red
F = F-Green
N = None

Power and Monitoring

S = 2.8 A - 6.6 A, non-monitored — power only
M = 2.8 A - 6.6 A, Fail-open monitoring⁹
R = 2.8 A - 6.6 A EQ integrated LINC 360⁴

Cable and Connector⁵

1 = 1 x Style 6 2-pole plug, 2 individual wires⁹
2 = 1 x Style 1 2-pole plug jacketed SO 2-core cables⁸
3 = 2 x Style 6 2-pole plug, 2 individual wires^{6,9}
4 = 2 x Style 1 2-pole plug jacketed SO 2-core
cables^{6,8,9}
5 = 1 x Flat 3-pole plug, 3 individual wires⁹
6 = 2 x Flat 3-pole plug, 3 individual wires⁹

Options

0 = None
1 = Arctic Kit⁷

Version

1 = Version 1

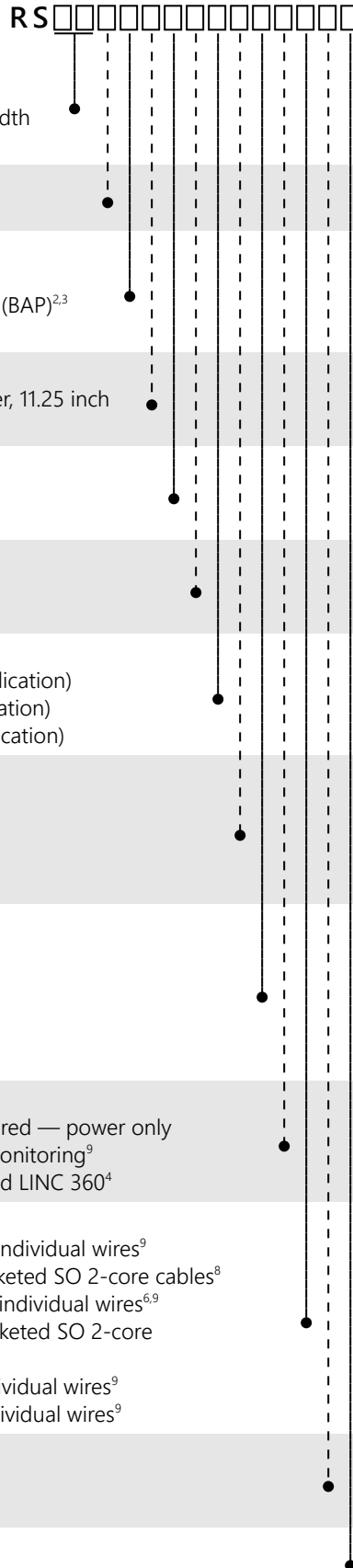

¹ Includes standards NATO, EASA, STAC, CAP 168, TP 312 and MOS 139.

² Required when FAA AIP funded.

³ If a 2-cord set fixture is required meeting BAP, digit 13, "Power and Monitoring", must be M.

⁴ EQ light fixtures are only available as a one connector option.

⁵ All Style 1 corded fixtures will include a ground lug. All Style 6 and 3-pole corded fixtures will be provided with grounding screw(s).

⁶ Only available in Power and Monitoring options S and M.

⁷ RE white/white and white/yellow applications meet the heat rise requirements in Engineering Brief 67D, section 2.13.1, "Arctic Kit Testing Requirements" WITHOUT an arctic kit. We do not offer an Arctic Kit with this configuration as the additional heat would be detrimental to the life of the LEDs.

⁸ SO cord set option is not compatible with shallow bases. If required please contact ADB Safegate.

⁹ Not ETL submitted or not applicable to FAA market.

6.3 Ordering Code LED Runway Edge, 60 m Width (R6 60 m) (ICAO)

Ordering Code

RSR6

Standard

1 = FAA/ICAO¹

Market Specific

0 = None

1 = Buy American Preference²

4 = German MIL 7-step FO

Dimensions

2 = 12 inch (305 mm), diameter 1.25 inch
BC (285 mm)

Prism

S = Standard Prism

R = Reinforced Prism

Beam Orientation

1 = Unidirectional

2 = Bidirectional

Toe-in

C = Curved³

L = Left³

R = Right³

Colors (Side 1 - Left)

W = White⁴

Y = Yellow⁴

R = Red⁵

F = F-Green⁵

Colors (Side 2 - Right)

W = White⁴

Y = Yellow⁴

R = Red⁵

F = F-Green⁵

N = None

Power and Monitoring

S = 2.8 A - 6.6 A, Non-Monitored - Power Only⁶

M = 2.8 A - 6.6 A, Fail-open monitoring⁶

R = 2.8 A - 6.6 A, ILCMS integrated OFDM EQ

Cable and Connector

1 = 1 x Style 6 2-pole plug, 2 individual wires⁷

2 = 1 x Style 1 2-pole plug, jacketed SO 2-core cable⁷

3 = 2 x Style 6 2-pole plug, 2 individual wires^{7,8}

4 = 2 x Style 1 2-pole plug, jacketed SO 2-core
cable^{7,8}

5 = 1 x flat 3-pole plug, 3 individual wires⁷

6 = 2 x flat 3-pole plug, 3 individual wires^{7,9}

Options

0 = None¹⁰

1 = Arctic Kit¹⁰

Version Control

1 = Version 1

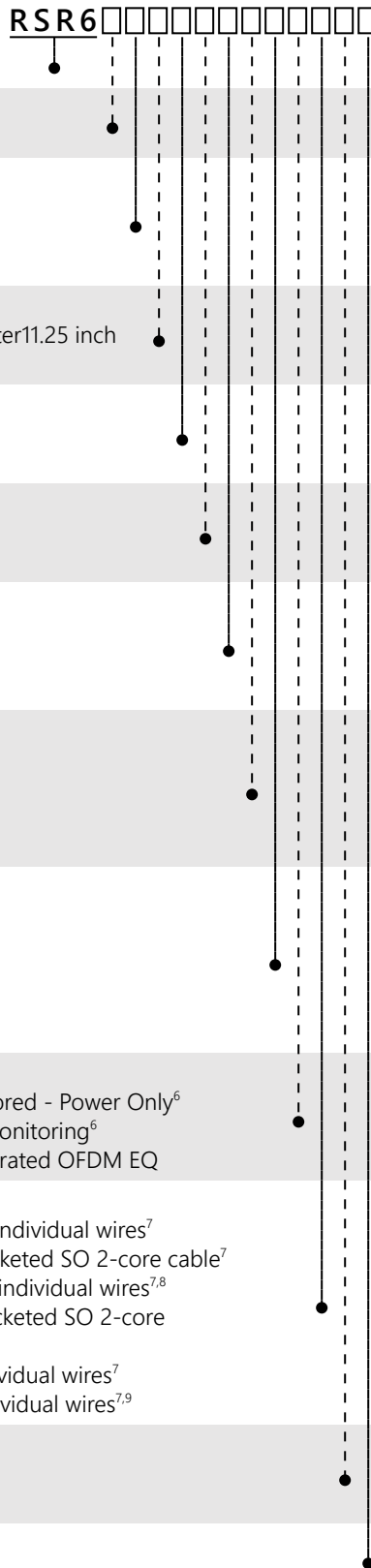

¹Includes NATO, EASA, STAC, TP-312, MOS 139

²If 2-cord set fixture, digit 13 must be M

³Bidirectional application - Place the required color option in Side 1 (Left) and 2 (Right). Left and right side determined by viewing fixture from runway centerline. Unidirectional application - Side 1 only, choosing left or right for correct toeing.

⁴Arctic Kit not needed

⁵Arctic Kit when necessary

⁶2-cord set option available

⁷All Style 1 corded fixtures will include a ground lug. All Style 6 or 3-pole corded fixtures will be provided without a ground lug UNLESS digit 6 is option 1 "BAP".

⁸Only available in digit 13 options S and M and bi-directional configuration

⁹Not valid option for uni-directional

¹⁰Red and Green require Arctic Kit

6.4 Ordering Code LED L- 850D(L) - Threshold, End, and Threshold/End (ICAO & FAA)

Ordering Code

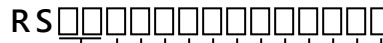

Application

RT = L-850D(L) Runway Threshold, Threshold End
 RN = L-850D(L) Runway End

Standards

2 = FAA

Market Specific

0 = None
 1 = Buy American Preference (BAP)^{1,2}

Dimensions

2 = 12 inch (305 mm) diameter, 11.25 inch BC (285 mm)

Prism

S = Standard prism
 R = Reinforced prism

Beam Orientation

1 = Unidirectional
 2 = Bidirectional

Toe-in

N = None (RN must be N)³
 L = Left (RT Green only, always toed)³
 R = Right (RT Green only, always toed)³

Color – Side 1

F = F-Green (Arctic kit required)
 R = Red (Arctic kit not required)

Color – Side 2

R = Red (Arctic kit not required)
 N = None

Power and Monitoring

S = 2.8 A - 6.6 A, non-monitored — power only
 M = 2.8 A - 6.6 A, Fail-open monitoring
 R = 2.8 A - 6.6 A, EQ integrated LINC 360⁴

Cable and Connector⁵

1 = 1 x Style 6 2-pole plug, 2 individual wires⁸
 2 = 1 x Style 1 2-pole plug, jacketed SO 2 core cable
 3 = 2 x Style 6 2-pole plug, 2 individual wires^{6,7}
 4 = 2 x Style 1 2-pole plug, jacketed SO 2 core cable^{6,7}

Options

0 = None
 1 = Arctic Kit

Version

1 = Version 1

¹ Required for FAA when AIP funded.

² If a 2-cord set fixture is required meeting BAP, digit 13, "Power and Monitoring", must be M.

³ L and R designations are always in relationship to Side 1 only.

⁴ EQ light fixtures are only available as a one connector option

⁵ All Style 1 corded fixtures will include a ground lug. All Style 6 and 3-pole corded fixtures will be provided with grounding screw(s).

⁶ Only available in Digit 13 options S and M and bi-directional configuration

⁷ Not ETL submitted or not applicable to FAA market

6.5 Ordering Code LED L- 850T(L) Takeoff/Hold (THL) & (RIL) Runway Intersection (FAA)

Ordering Code

Application

RS = Runway Status; Takeoff/ Hold
(THL); L-850T(L) (RIL);
Runway Intersection

TS = Runway Status; Runway Entry
(REL)¹

Standards

2 = FAA

Market Specific

0 = None

1 = Buy American Preference (BAP)

Dimensions

1 = 8 inch (203 mm) diameter³

2 = 12 inch (305 mm) diameter 11.25 inch
BC (285 mm)

3 = 8 inch (203 mm) diameter 4-bolt³

Prism

S = Standard prism

R = Reinforced prism³

Beam Orientation

1 = Unidirectional

Toe-in

N= None

Color – Side 1

R = Red

Color – Side 2

N= Not applicable

Power and Monitoring

R = 2.8 A - 6.6 A, EQ integrated LINC 360

Cable and connector¹

1 = 1 x Style 6 2-pole plug, 2 individual Wires

2 = 1 x Style 1 2-pole plug, jacketed SO 2-core cable²

Options

0 = None

1 = Arctic Kit

Version Control

1 = Version 1

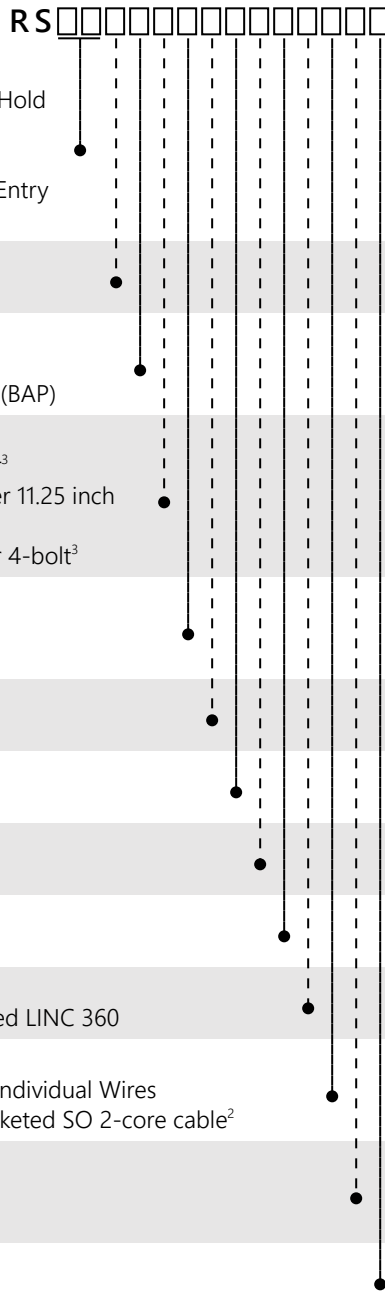

¹ All Style 1 corded fixtures will include a ground lug. All Style 6 and 3-pole corded fixtures will be provided with grounding screw(s).

² SO cord set option is not compatible with shallow bases. If required please contact ADB Safegate.

³ Not ETL submitted

6.6 Ordering Code LED Takeoff/Hold (THL) & (RIL) Runway Intersection (ICAO)

Ordering Code

Application¹

RS = Runway Status; Takeoff/ Hold (THL); L-850T(L) (RIL); Runway Intersection
 TS = Runway Status; Runway Entry (REL)

Standards

3 = ICAO

Market Specific

0 = None

Dimensions

1 = 8 inch (203 mm) diameter
 2 = 12 inch (305 mm) diameter 11.25 inch BC (285 mm)
 3 = 8 inch (203 mm) Diameter 4-bolt²

Prism

S = Standard prism
 R = Reinforced prism¹

Beam Orientation

1 = Unidirectional

Toe-in

N = None

Color – Side 1 (Left)

R = Red

Color – Side 2 (Right)

N = Blank

Power and Monitoring

R = 2.8 A - 6.6 A, ILCMS integrated OFDM EQ

Cable and connector

2 = 1 x Style 6 2-Pole Plug, 2 Individual Wires
 2 = 1 x Style 1 2-Pole Plug, Jacketed SO 2 Core Cable

Options

0 = None
 1 = Arctic Kit

Version

1 = Version 1

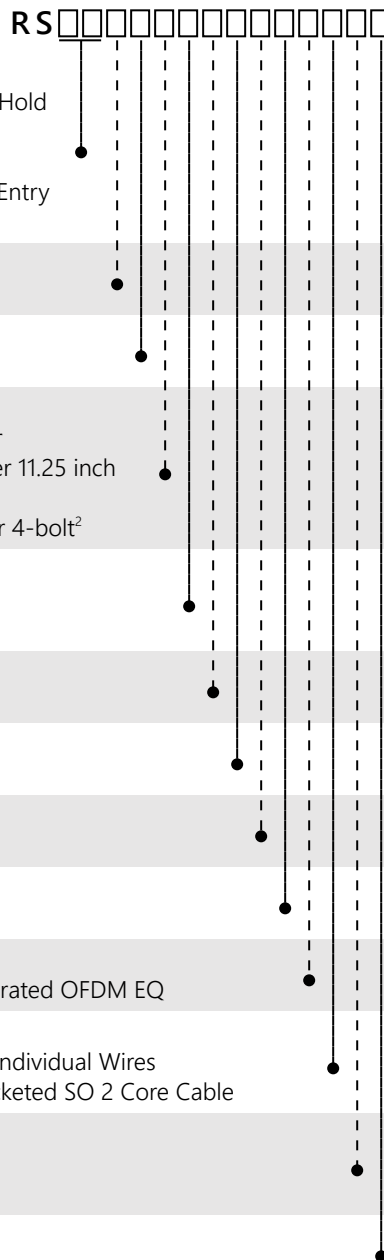

¹ All Style 1 corded fixtures will include a ground lug. All Style 6 and 3-pole corded fixtures will be provided with grounding screw(s).

² SO cord set option is not compatible with shallow bases. If required please contact ADB Safegate

6.7 Ordering Code LED Stopway 45 m (ICAO)

Ordering Code

RS□□□□□□□□□□

Application

SW= Stopway 45 m

Standards

3 = ICAO ¹

Market Specific

0 = None

Dimensions

2 = 12 inch (305 mm) diameter, 11.25 inch
BC (285 mm).

Prism

S = Standard prism
R = Reinforced prism

Beam Orientation

1 = Unidirectional

Toe-in

L = Left
R = Right

Color (Side 1 – Left)

R = Red

Color (Side 2 – Right)

N = None

Power and Monitoring

S = 2.8 A - 6.6 A non-monitored - power only
M = 2.8 A - 6.6 A Fail-Open monitoring
R = 2.8 A - 6.6 A EQ integrated LINC 360

Cable and Connector ²

1 = 1 x Style 6 2-pole plug, 2 individual wires
2 = 1 x Style 1 2-pole plug, jacketed SO 2-core cable
5 = 1 x flat 3-pole plug, 3 individual wires

Options

0 = None
1 = Arctic Kit

Version Control

1 = Version 1

¹ Includes standards NATO, EASA, STAC, TP 312 and MOS 139.

² All Style 1 corded fixtures will include a ground lug. All Style 6 or 3-pole corded fixtures will be provided with grounding screw(s).

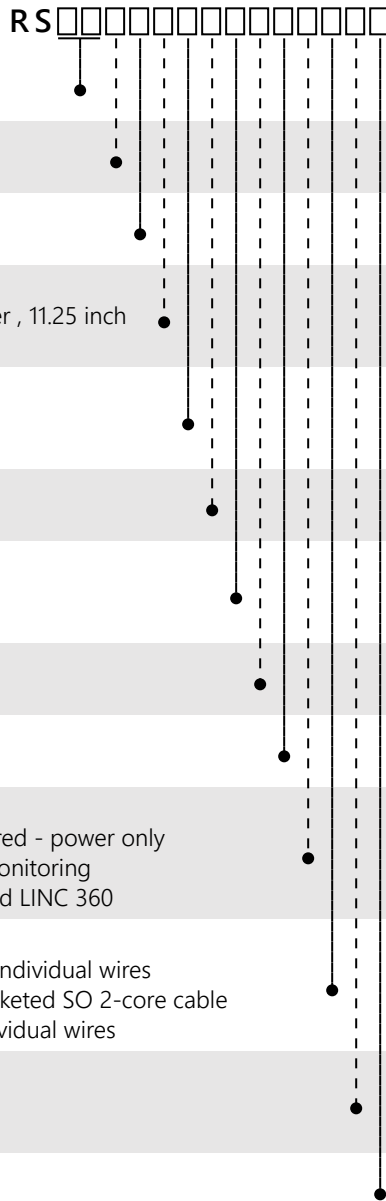

6.8 Ordering Code LED Stopway (S6 60 m Width) (ICAO)

Ordering Code

Application

S6 = Stopway 60 m Runway

Standards

3 = ICAO

Market Specific

0 = None

Dimensions

2 = 12 inch (304 mm) diameter, 11.25 inch BC (285 mm)

Prism

S = Standard prism
R = Reinforced prism

Beam Orientation

1 = Unidirectional

Toe-in

L = Left
R = Right

Color (Side 1 – Left)

R = Red

Color (Side 2 – Right)

N = None

Power and Monitoring

S = 2.8 A - 6.6 A non-monitored - power only
M = 2.8 A - 6.6 A Fail-Open monitoring
R = 2.8 A - 6.6 A EQ integrated LINC 360

Cable and Connector

1 = 1 x Style 6 2-pole plug, 2 individual wires¹
2 = 1 x Style 1 2-pole plug, jacketed SO 2-core cable¹
5 = 1 x flat 3-pole plug, 3 individual wires¹

Options

0 = None
1 = Arctic Kit

Version Control

1 = Version 1

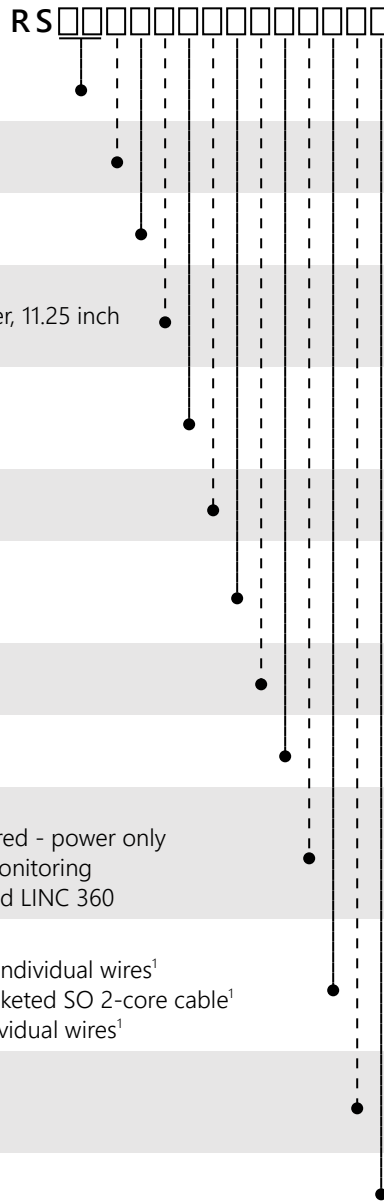

¹All Style 1 corded fixtures will include a ground lug. All Style 6 or 3-pole corded fixtures will be provided with a grounding screw.

6.9 Ordering Code LED RETIL (ICAO)

Ordering Code

Application

RY = Rapid Exit Taxiway Indicator
Light (RETIL)

Standards

3 = ICAO¹

Market Specific

0 = None
4 = German Military 7-step FO

Dimensions

1 = 8 inch (203 mm) diameter
2 = 12 inch (305 mm) diameter, 11.25 inch
BC (285 mm)

Prism

S = Standard prism
R = Reinforced prism

Beam Orientation

1 = Unidirectional

Toe-in

N = None

Color – Side 1 (Left)

Y = Yellow

Color – Side 2 (Right)

N = None

Power and Monitoring

M = 2.8 A - 6.6 A Fail-Open monitoring
R = 2.8 A - 6.6 A, EQ Integrated LINC 360

Cable and connector²

1 = 1 x Style 6 2-pole plug, 2 individual wires
2 = 1 x Style 1 2-pole plug, jacketed SO 2-core cable³
5 = 1 x Flat 3-pole plug, 3 individual wires

Options

0 = None
1 = Arctic Kit

Version

1 = Version 1

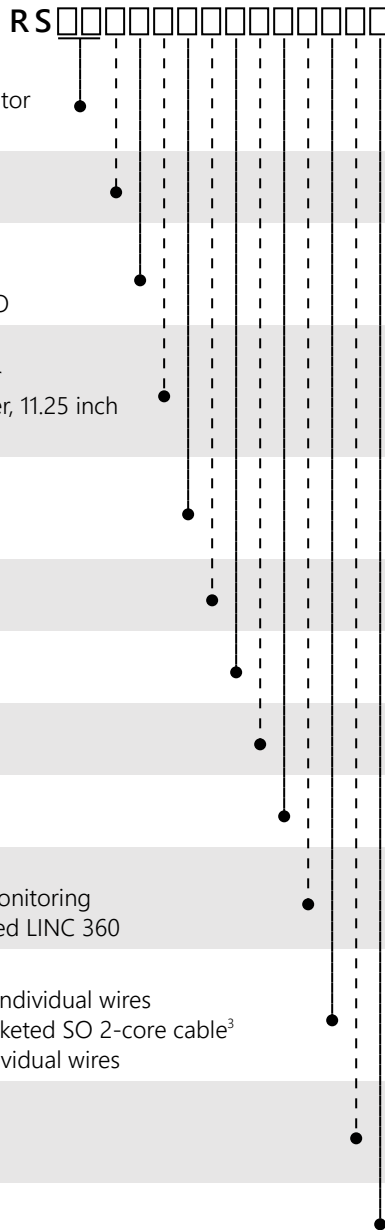

¹ Includes standards NATO, EASA, STAC, TP 312 and MOS 139

² EQ light fixtures are only available as a one-connector option.

³ All Style 1 corded fixtures will include a ground lug. All Style 6 or 3-pole corded fixtures will be provided with grounding screw(s).

6.10 Ordering Code LED L- 852(L) Runway Guard Light (ICAO & FAA)

Ordering Code

Application

RG= L-852(L) Runway Guard Light

Standards

1 = FAA/ICAO

Market Specific

0 = None

1 = Buy American Preference¹

Dimensions

1 = 8 inch (203 mm) diameter

2 = 12 inch (304 mm) diameter, 11.25 inch BC (285 mm)

3 = 8 inch (203 mm) diameter, 4-bolt²

Prism

S = Standard prism

R = Reinforced prism

Beam Orientation

1 = Unidirectional

Toe-in

N = None

Color (Side 1 – Left)

Y = Yellow

Programming (Side 2 – Right)³

0 = Flash-off

1 = Flash-on

Power and Monitoring

R = 2.8 A - 6.6 A, EQ Integrated - LINC 360

S = 2.8 A - 6.6 A Non-Monitored - Autonomous

Cable and Connector

1 = 1 x Style 6 2-pole plug, 2 individual wires⁴

2 = 1 x Style 1 2-pole plug, jacketed SO 2 core cable^{4,5}

5 = 1 x Flat 3-pole plug, 3 Individual Wires⁴

Options

0 = None

1 = Arctic Kit

Version Control

1 = Version 1

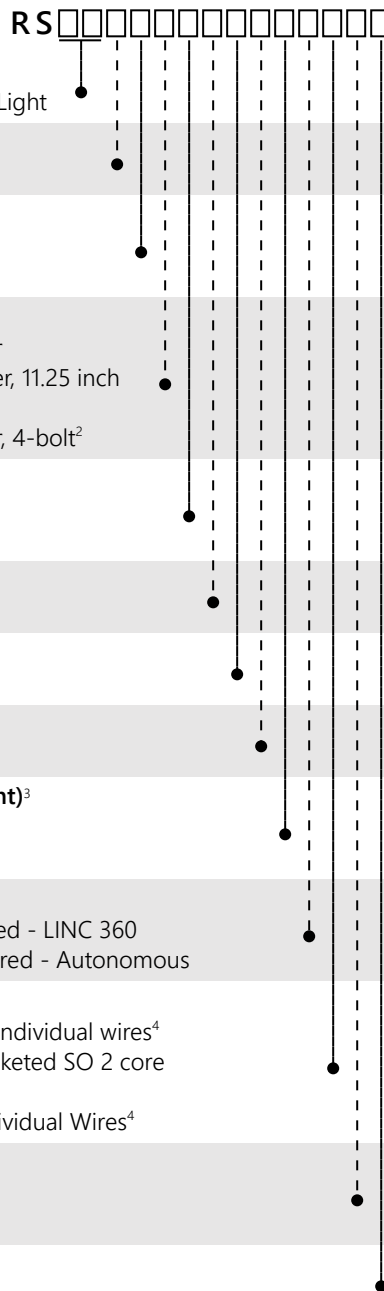

¹ Required for USA FAA market.

² 8"- 4 bolt top cover fixtures are not compatible with 8" shallow bases.

³ Side 2 will include a non-light producing window on the autonomous version which provides access to the internal optical sensor, allowing the Local Programming Device to change flash programming. All fixtures must be ordered as either flash-off or flash-on. Typically, it is a 50/50 split between the two options.

⁴ All Style 1 corded fixtures will include a ground lug. All Style 6 or 3-pole corded fixtures will be provided with grounding screw(s).

⁵ Style 1 SO cord-set not compatible with 8" shallow bases using side entry.

7.0 Spare Parts

Spare parts are available for inset light fixtures with and without the control and monitoring functionality. For more information, see www.adbsafegate.com and the spare part lists, or contact ADB SAFEGATE for assistance.

7.1 Versions and Exploded View

Partial Exploded View — Spare part Assemblies

Figure 60: 8-Inch Fixtures (Left) & 12-Inch Fixtures (Right)

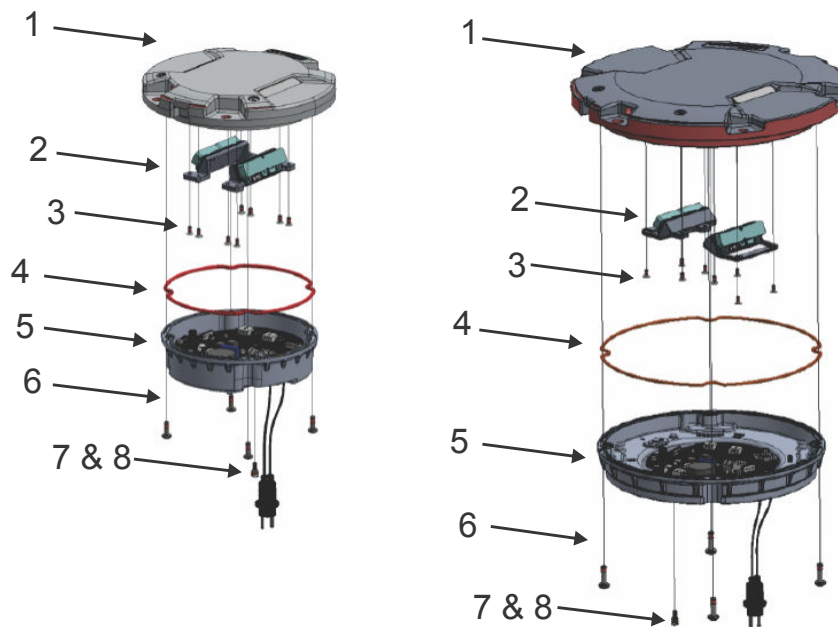

Call-out	Description	Assembly number prefix
1	Top Cover Assembly, 8-inch	SP.AS00019-XXX
1	Top Cover Assembly, 12-inch	SP.AS00018-XXX
2	Light Engine Assembly, 8-inch	SP.AS00020-XXX
2	Light Engine Assembly, 12-inch	SP.AS00023-XXX
3	Mounting Screws, Light Engine	SP.MFPM4PT-708-01
4	Gasket, 8" Bottom Pan	SP.MS00005-000-01
4	Gasket, 12" Bottom Pan	SP.MS00006-000-01
5	Bottom Pan Assembly, 8-inch	SP.AS00021-XXX
5	Bottom Pan Assembly, 12-inch	SP.AS00024-XXX
6	Mounting Screws, 8" Bottom Pan	SP.MFPM5PT-714-01
6	Mounting Screws, 12" Bottom Pan	SP.MFPM6PT-720-01
7 & 8	Pressure Relief Screw with O-ring	SP.MF00090-000-01

7.2 Spare Parts Illustration

Figure 61: Top Cover Assembly

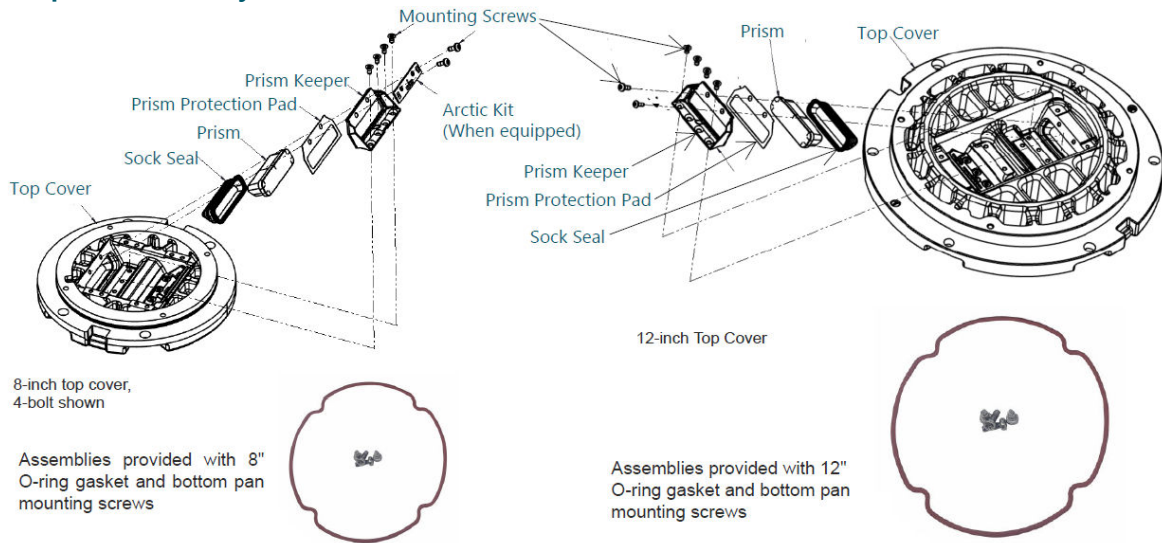

Figure 62: Bottom Pan Assembly, 8-inch



Figure 63: Bottom Pan Assembly, 12-inch



Shown with Gasket Installed

All Bottom Pan assemblies are fully populated (power supply, cord set, ground lug or ground screw) and provided with the O-ring gasket and (4) bottom pan mounting screws.

Figure 64: Bottom Pan Gasket, 8-inch, Package of 10



Figure 65: Bottom Pan Gasket, 12-inch Package of 10

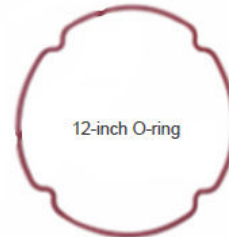

Figure 66: LED Light Engines Wire Harness, Package of 10



Sized for 8" and 12" Fixtures

Figure 67: Light Engine Assembly, Package of 2



8" Fixture Light Engines



12" Fixture Light Engines

Figure 68: Prism Kit, Package of 2



- Available in standard or protected (sapphire) prism.
- Kit includes the Prism, Sock Seal (both shown), Prism Protection Pad, Prism Keeper and all mounting screws.

Figure 69: Ground Lugs, Package of 5



Figure 70: Style-1 Cord Set Cable Clamp, Package of 5



Figure 71: Mounting Screws, Package of 100



Figure 72: Pressure Release Screws, Package of 5



Figure 73: Arctic Kit, Package of 2

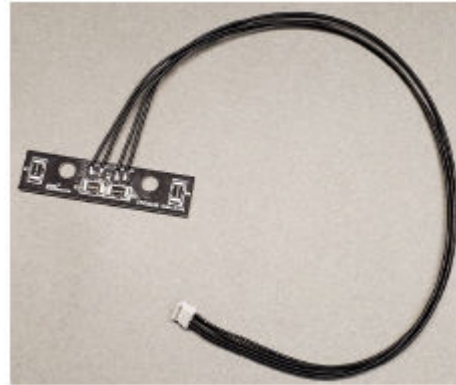

i Note

- Pressure release screw O-ring is to be replaced with new O-ring prior to re-installation of the pressure release screw.

7.3 Spare Parts - Runway Centerline, L - 850A(L) (ICAO & FAA)

i Note

- Each Top Cover Assembly includes a Bottom Cover Gasket and a Bottom Cover Screws.
- BAP stands for "Buy American Preference".

A1 - Top Cover assemblies (2-bolt), 8", with heater	Quantity per		spare part code
	fitting	spare part	
Unidirectional, standard prism, non-monitored (S-BAP) and EQ (R)	1	1	SPAS00019-3AG
Unidirectional, reinforced prism, non-monitored (S-BAP) and EQ (R)	1	1	SPAS00019-3AS
Unidirectional, standard prism, non-monitored (S-non-BAP) and monitored (M)	1	1	SPAS00019-3BG
Unidirectional, reinforced prism, non-monitored (S-non-BAP) and monitored (M)	1	1	SPAS00019-3BS
Bidirectional, standard prism, non-monitored (S-BAP) and EQ (R)	1	1	SPAS00019-4AG
Bidirectional, reinforced prism, non-monitored (S-BAP) and EQ (R)	1	1	SPAS00019-4AS
Bidirectional, standard prism, non-monitored (S-non-BAP) and monitored (M)	1	1	SPAS00019-4BG
Bidirectional, reinforced prism, non-monitored (S-non-BAP) and monitored (M)	1	1	SPAS00019-4BS

A1 - Top Cover assemblies (2-bolt), 8", no heater	Quantity per		spare part code
	fitting	spare part	
Unidirectional, standard prism	1	1	SPAS00019-3NG
Unidirectional, reinforced prism	1	1	SPAS00019-3NS
Bidirectional, standard prism	1	1	SPAS00019-4NG
Bidirectional, reinforced prism	1	1	SPAS00019-4NS

A1 - Top Cover assemblies (4-bolt), 8", with heater	Quantity per		spare part code
	fitting	spare part	
Unidirectional, standard prism, non-monitored (S-BAP) and EQ (R)	1	1	SPAS00019-5AG
Unidirectional, reinforced prism, non-monitored (S-BAP) and EQ (R)	1	1	SPAS00019-5AS
Unidirectional, standard prism, non-monitored (S-non-BAP) and monitored (M)	1	1	SPAS00019-5BG
Unidirectional, reinforced prism, non-monitored (S-non-BAP) and monitored (M)	1	1	SPAS00019-5BS
Bidirectional, standard prism, non-monitored (S-BAP) and EQ (R)	1	1	SPAS00019-6AG
Bidirectional, reinforced prism, non-monitored (S-BAP) and EQ (R)	1	1	SPAS00019-6AS
Bidirectional, standard prism, non-monitored (S-non-BAP) and monitored (M)	1	1	SPAS00019-6BG
Bidirectional, reinforced prism, non-monitored (S-non-BAP) and monitored (M)	1	1	SPAS00019-6BS

A1 - Top Cover assemblies (4-bolt), 8", no heater	Quantity per		spare part code
	fitting	spare part	
Unidirectional, standard prism	1	1	SPAS00019-5NG
Unidirectional, reinforced prism	1	1	SPAS00019-5NS
Bidirectional, standard prism	1	1	SPAS00019-6NG
Bidirectional, reinforced prism	1	1	SPAS00019-6NS

A2 - Top Cover assemblies, 12", with heater	Quantity per		spare part code
	fitting	spare part	
Unidirectional, standard prism, non-monitored (S-BAP) and EQ (R)	1	1	SPAS00018-UAG
Unidirectional, reinforced prism, non-monitored (S-BAP) and EQ (R)	1	1	SPAS00018-UAS
Unidirectional, standard prism, non-monitored (S-non-BAP) and monitored (M)	1	1	SPAS00018-UBG
Unidirectional, reinforced prism, non-monitored (S-non-BAP) and monitored (M)	1	1	SPAS00018-UBS
Bidirectional, standard prism, non-monitored (S-BAP) and EQ (R)	1	1	SPAS00018-BAG
Bidirectional, reinforced prism, non-monitored (S-BAP) and EQ (R)	1	1	SPAS00018-BAS
Bidirectional, standard prism, non-monitored (S-non-BAP) and monitored (M)	1	1	SPAS00018-BBG
Bidirectional, reinforced prism, non-monitored (S-non-BAP) and monitored (M)	1	1	SPAS00018-BBS

A2 - Top Cover assemblies, 12", no heater	Quantity per		spare part code
	fitting	spare part	
Unidirectional, standard prism	1	1	SPAS00018-UNG
Unidirectional, reinforced prism	1	1	SPAS00018-UNS
Bidirectional, standard prism	1	1	SPAS00018-BNG
Bidirectional, reinforced prism	1	1	SPAS00018-BNS

AXON Runway Inset Lights, 8-inch and 12-inch
Spare Parts

B1 - Light engine assembly, 8"	Quantity per		spare part code
	fitting	spare part	
Runway Centerline, FAA L-850A(L), red, straight	1 or 2	1	SPAS00020-SR1
Runway Centerline, FAA L-850A(L), white, straight	1 or 2	1	SPAS00020-SW2

B1 - Light engine assembly, 12"	Quantity per		spare part code
	fitting	spare part	
Runway Centerline, FAA L-850A(L), red, straight	1 or 2	1	SPAS00023-SR1
Runway Centerline, FAA L-850A(L), white, straight	1 or 2	1	SPAS00023-SW2

C - Bottom pan assembly, 8"	Quantity per		spare part code
	fitting	spare part	
Non-monitored converter, style 6 cord set	1	1	SPAS00021-L13
Non-monitored converter, 3-pole cord set	1	1	SPAS00021-L1F
Non-monitored converter, style 1 SJO jacketed cord set	1	1	SPAS00021-L1J
Non-monitored converter, 2-con style 6 cord sets	1	1	SPAS00021-L23
Non-monitored converter, 2-con 3-pole cord sets	1	1	SPAS00021-L2F
Non-monitored converter, 2-con style 1 SJO jacketed cord sets	1	1	SPAS00021-L2J
Buy American Preference non-monitored converter, style 6 cord set	1	1	SPAS00021-S13
Buy American Preference non-monitored converter, style 1 SJO jacketed cord set	1	1	SPAS00021-S1J
Monitored converter, style 6 cord set	1	1	SPAS00021-M13
Monitored converter, 3-pole cord set	1	1	SPAS00021-M1F
Monitored converter, style 1 SJO jacketed cord set	1	1	SPAS00021-M1J
Monitored converter, 2-con style 6 cord sets	1	1	SPAS00021-M23
Monitored converter, 2-con 3-pole cord sets	1	1	SPAS00021-M2F
Monitored converter, 2-con style 1 SJO jacketed cord sets	1	1	SPAS00021-M2J

C - Bottom pan assembly, 8"	Quantity per		spare part code
	fitting	spare part	
EQ converter, style 6 cord set	1	1	SP.AS00021-R13
EQ converter, 3-pole cord set	1	1	SP.AS00021-R1F
EQ converter, style 1 SJO jacketed cord set	1	1	SP.AS00021-R1J

C - Bottom pan assembly, 12"	Quantity per		spare part code
	fitting	spare part	
Non-monitored converter, style 6 cord set	1	1	SP.AS00024-L13
Non-monitored converter, 3-pole cord set	1	1	SP.AS00024-L1F
Non-monitored converter, style 1 SJO jacketed cord set	1	1	SP.AS00024-L1J
Non-monitored converter, 2-con style 6 cord sets	1	1	SP.AS00024-L23
Non-monitored converter, 2-con 3-pole cord sets	1	1	SP.AS00024-L2F
Non-monitored converter, 2-con style 1 SJO jacketed cord sets	1	1	SP.AS00024-L2J
Buy American Preference non-monitored converter, style 6 cord set	1	1	SP.AS00024-S13
Buy American Preference non-monitored converter, style 1 SJO jacketed cord set	1	1	SP.AS00024-S1J
Monitored converter, style 6 cord set	1	1	SP.AS00024-M13
Monitored converter, 3-pole cord set	1	1	SP.AS00024-M1F
Monitored converter, style 1 SJO jacketed cord set	1	1	SP.AS00024-M1J
Monitored converter, 2-con style 6 cord sets	1	1	SP.AS00024-M23
Monitored converter, 2-con 3-pole cord sets	1	1	SP.AS00024-M2F
Monitored converter, 2-con style 1 SJO jacketed cord sets	1	1	SP.AS00024-M2J
EQ converter, style 6 cord set	1	1	SP.AS00024-R13
EQ converter, 3-pole cord set	1	1	SP.AS00024-R1F
EQ converter, style 1 SJO jacketed cord set	1	1	SP.AS00024-R1J

Cordsets	Quantity per		spare part code
	fitting	spare part	
Cord set, L-823 style 1, 8" bottom pan	1 or 2	5	SP.73A0193/1
Cord set, L-823 style 1, 12" bottom pan	1 or 2	5	SP.73A0194/1
Cord set, L-823 style 6, 8" & 12" bottom pan	1 or 2	5	SP.SGE96253351
Cord set, 3-pole, 8" & 12" bottom pan	1 or 2	5	SP.SGEFR500160
Cable retaining clamp, for use with style 1 cord set	1 or 2	5	SP.MB00003-013-01
Ground lug kit	1	5	SP.72A0401

Prism spares	Quantity per		spare part code
	fitting	spare part	
Prism kit, runway standard	1 or 2	2	SP.MG00001-G00-03
Prism kit, runway reinforced	1 or 2	2	SP.MG00001-S00-03
Prism gasket, Runway	1 or 2	10	SP.MS00004-000-02

Screws & gaskets	Quantity per		spare part code
	fitting	spare part	
Pressure release screw with o-ring	1	5	SP.MF00090-000-01
Gasket, 8" Bottom pan	1	10	SP.MS00005-000-01
Screws, 8" Bottom pan	-	100	SP.MFPM5PT-714-01
Gasket, 12" Bottom pan	1	10	SP.MS00006-000-01
Screws, light engine assembly mounting	-	100	SP.MFPM4PT-710-01
Screws, 12" Bottom pan	-	100	SP.MFPM6PT-720-01

Heater kits	Quantity per		spare part code
	fitting	spare part	
Heater kit with harness - non-monitored (S-BAP) & EQ	1 or 2	2	SPEP00038-R00-01
Heater kit with harness - non-monitored (S-non-BAP) & monitored	1 or 2	2	SPEP00038-R01-01

Wire harness	Quantity per		spare part code
	fitting	spare part	
Wire harness, power supply to light engine	1 or 2	10	SP.EW00079-000-01

Fuse	Quantity per		spare part code
	fitting	spare part	
Fuse Resistors (only for fixtures with monitoring (M))	1 or 2	20	6132.00.250

 **Note**

All screws for fastening are included.

Component availability or design may be subject to change due to unforeseen circumstances. This document is subject to change or new information from ADB SAFEGATE, as and when available or if required, with reservation for error or price changes.

For more information or assistance with ordering spare parts, contact ADB SAFEGATE, see www.adbsafegate.com.

7.4 Spare Parts - Touchdown Zone, L - 850B(L) (ICAO & FAA)



Note

- Each Top Cover Assembly includes a Bottom Cover Gasket and a Bottom Cover Screws.
- BAP stands for "Buy American Preference".

A1 - Top Cover assemblies (2-bolt), 8", with heater	Quantity per		spare part code
	fitting	spare part	
Unidirectional, standard prism, non-monitored (S-BAP) and EQ (R)	1	1	SPAS00019-3AG
Unidirectional, reinforced prism, non-monitored (S-BAP) and EQ (R)	1	1	SPAS00019-3AS
Unidirectional, standard prism, non-monitored (S-non-BAP) and monitored (M)	1	1	SPAS00019-3BG
Unidirectional, reinforced prism, non-monitored (S-non-BAP) and monitored (M)	1	1	SPAS00019-3BS

A1 - Top Cover assemblies (2-bolt), 8", no heater	Quantity per		spare part code
	fitting	spare part	
Unidirectional, standard prism	1	1	SPAS00019-3NG
Unidirectional, reinforced prism	1	1	SPAS00019-3NS

A1 - Top Cover assemblies (4-bolt), 8", with heater	Quantity per		spare part code
	fitting	spare part	
Unidirectional, standard prism, non-monitored (S-BAP) and EQ (R)	1	1	SPAS00019-5AG
Unidirectional, reinforced prism, non-monitored (S-BAP) and EQ (R)	1	1	SPAS00019-5AS
Unidirectional, standard prism, non-monitored (S-non-BAP) and monitored (M)	1	1	SPAS00019-5BG
Unidirectional, reinforced prism, non-monitored (S-non-BAP) and monitored (M)	1	1	SPAS00019-5BS

A1 - Top Cover assemblies (4-bolt), 8", no heater	Quantity per		spare part code
	fitting	spare part	
Unidirectional, standard prism	1	1	SPAS00019-5NG
Unidirectional, reinforced prism	1	1	SPAS00019-5NS

A2 - Top Cover assemblies, 12", with heater	Quantity per		spare part code
	fitting	spare part	
Unidirectional, standard prism, non-monitored (S-BAP) and EQ (R)	1	1	SPAS00018-UAG
Unidirectional, reinforced prism, non-monitored (S-BAP) and EQ (R)	1	1	SPAS00018-UAS
Unidirectional, standard prism, non-monitored (S-non-BAP) and monitored (M)	1	1	SPAS00018-UBG
Unidirectional, reinforced prism, non-monitored (S-non-BAP) and monitored (M)	1	1	SPAS00018-UBS

A2 - Top Cover assemblies, 12", no heater	Quantity per		spare part code
	fitting	spare part	
Unidirectional, standard prism	1	1	SP.AS00018-UNG
Unidirectional, reinforced prism	1	1	SP.AS00018-UNS

B1 - Light engine assembly, 8"	Quantity per		spare part code
	fitting	spare part	
Runway Touchdown Zone, FAA L-850B(L), white, left toe	1	1	SP.AS00020-LW2
Runway Touchdown Zone, FAA L-850B(L), white, straight	1	1	SP.AS00020-SW2
Runway Touchdown Zone, FAA L-850B(L), white, right toe	1	1	SP.AS00020-RW2

B1 - Light engine assembly, 12"	Quantity per		spare part code
	fitting	spare part	
Runway Touchdown Zone, FAA L-850B(L), white, left toe	1	1	SP.AS00023-LW2
Runway Touchdown Zone, FAA L-850B(L), white, straight	1	1	SP.AS00023-SW2
Runway Touchdown Zone, FAA L-850B(L), white, right toe	1	1	SP.AS00023-RW2

C - Bottom pan assembly, 8"	Quantity per		spare part code
	fitting	spare part	
Non-monitored converter, style 6 cord set	1	1	SP.AS00021-L13
Non-monitored converter, 3-pole cord set	1	1	SP.AS00021-L1F
Non-monitored converter, style 1 SJO jacketed cord set	1	1	SP.AS00021-L1J
Buy American Preference non-monitored converter, style 6 cord set	1	1	SP.AS00021-S13
Buy American Preference non-monitored converter, style 1 SJO jacketed cord set	1	1	SP.AS00021-S1J
Monitored converter, style 6 cord set	1	1	SP.AS00021-M13
Monitored converter, 3-pole cord set	1	1	SP.AS00021-M1F
Monitored converter, style 1 SJO jacketed cord set	1	1	SP.AS00021-M1J
EQ converter, style 6 cord set	1	1	SP.AS00021-R13
EQ converter, 3-pole cord set	1	1	SP.AS00021-R1F
EQ converter, style 1 SJO jacketed cord set	1	1	SP.AS00021-R1J

C - Bottom pan assembly, 12"	Quantity per		spare part code
	fitting	spare part	
Non-monitored converter, style 6 cord set	1	1	SP.AS00024-L13
Non-monitored converter, 3-pole cord set	1	1	SP.AS00024-L1F
Non-monitored converter, style 1 SJO jacketed cord set	1	1	SP.AS00024-L1J
Buy American Preference non-monitored converter, style 6 cord set	1	1	SP.AS00024-S13
Buy American Preference non-monitored converter, style 1 so cord set	1	1	SP.AS00024-S1J
Monitored converter, style 6 cord set	1	1	SP.AS00024-M13
Monitored converter, 3-pole cord set	1	1	SP.AS00024-M1F
Monitored converter, style 1 SJO jacketed cord set	1	1	SP.AS00024-M1J

C - Bottom pan assembly, 12"	Quantity per		spare part code
	fitting	spare part	
EQ converter, style 6 cord set	1	1	SP.AS00024-R13
EQ converter, 3-pole cord set	1	1	SP.AS00024-R1F
EQ converter, style 1 SJO jacketed cord set	1	1	SP.AS00024-R1J

Cordsets	Quantity per		spare part code
	fitting	spare part	
Cord set, L-823 style 1, 8" bottom pan	1	5	SP.73A0193/1
Cord set, L-823 style 1, 12" bottom pan	1	5	SP.73A0194/1
Cord set, L-823 style 6, 8" & 12" bottom pan	1	5	73A0136/18
Cord set, 3-pole, 8" & 12" bottom pan	1	5	SP.SGFR500160
Cable retaining clamp, for use with style 1 cord set	1	5	SP.MB00003-013-01
Ground lug kit	1	5	SP.72A0401

Prism spares	Quantity per		spare part code
	fitting	spare part	
Prism kit, runway standard	1	2	SP.MG00001-G00-03
Prism kit, runway reinforced	1	2	SP.MG00001-S00-03
Prism gasket, Runway	1	10	SP.MS00004-000-02

Screws & gaskets	Quantity per		spare part code
	fitting	spare part	
Pressure release screw with o-ring	1	5	SP.MF00090-000-01
Gasket, 8" Bottom pan	1	10	SP.MS00005-000-01
Screws, 8" Bottom pan	-	100	SP.MFPM5PT-714-01
Gasket, 12" Bottom pan	1	10	SP.MS00006-000-01
Screws, light engine assembly mounting	-	100	SP.MFPM4PT-710-01
Screws, 12" Bottom pan	-	100	SP.MFPM6PT-720-01

Heater kits	Quantity per		spare part code
	fitting	spare part	
Heater kit with harness - non-monitored (S-BAP) & EQ	1	2	SP.EP00038-R00-01
Heater kit with harness - non-monitored (S-non-BAP) & monitored	1	2	SP.EP00038-R01-01

Wire harness	Quantity per		spare part code
	fitting	spare part	
Wire harness, power supply to light engine	1	10	SP.EW00079-000-01

Fuse	Quantity per		spare part code
	fitting	spare part	
Fuse Resistors (only for fixtures with monitoring (M))	1	20	6132.00.250



Note

All screws for fastening are included.

Component availability or design may be subject to change due to unforeseen circumstances. This document is subject to change or new information from ADB SAFEGATE, as and when available or if required, with reservation for error or price changes.

For more information or assistance with ordering spare parts, contact ADB SAFEGATE, see www.adbsafegate.com.

7.5 Spare Parts - Runway Edge 45 m, L- 850C(L) (ICAO & FAA)



Note

- Each Top Cover Assembly includes a Bottom Cover Gasket and a Bottom Cover Screws.
- BAP stands for "Buy American Preference".

A2 - Top Cover assemblies 12", with heater	Quantity per		spare part code
	fitting	spare part	
Unidirectional, standard prism, non-monitored (S-BAP) and EQ (R)	1	1	SPAS00018-UAG
Unidirectional, reinforced prism, non-monitored (S-BAP) and EQ (R)	1	1	SPAS00018-UAS
Unidirectional, standard prism, non-monitored (S-non-BAP) and monitored (M)	1	1	SPAS00018-UBG
Unidirectional, reinforced prism, non-monitored (S-non-BAP) and monitored (M)	1	1	SPAS00018-UBS
Bidirectional, standard prism, non-monitored (S-BAP) and EQ (R)	1	1	SPAS00018-BAG
Bidirectional, reinforced prism, non-monitored (S-BAP) and EQ (R)	1	1	SPAS00018-BAS
Bidirectional, standard prism, non-monitored (S-non-BAP) and monitored (M)	1	1	SPAS00018-BBG
Bidirectional, reinforced prism, non-monitored (S-non-BAP) and monitored (M)	1	1	SPAS00018-BBS

A2 - Top Cover assemblies 12", no heater	Quantity per		spare part code
	fitting	spare part	
Unidirectional, standard prism	1	1	SPAS00018-UNG
Unidirectional, reinforced prism	1	1	SPAS00018-UNS
Bidirectional, standard prism	1	1	SPAS00018-BNG
Bidirectional, reinforced prism	1	1	SPAS00018-BNS

B1- Light engine assembly, 12"	Quantity per		spare part code
	fitting	spare part	
FAA L-850C(L), F-green, left toe	1	1	SPAS00023-LF2-RE
FAA L-850C(L), F-green, right toe	1	1	SPAS00023-RF2-RE
Runway Edge, FAA L-850C(L), red, left toe	1	1	SPAS00023-LR2
Runway Edge, FAA L-850C(L), red, right toe	1	1	SPAS00023-RR2
Runway Edge, FAA L-850C(L), white, left toe	1	1	SPAS00023-LW3
Runway Edge, FAA L-850C(L), white, right toe	1	1	SPAS00023-RW3
Runway Edge, FAA L-850C(L), yellow, left toe	1	1	SPAS00023-LY3
Runway Edge, FAA L-850C(L), yellow, right toe	1	1	SPAS00023-RY3

C - Bottom pan assembly, 12"	Quantity per		spare part code
	fitting	spare part	
Non-monitored converter, style 6 cord set	1	1	SPAS00024-L13
Non-monitored converter, 3-pole cord set	1	1	SPAS00024-L1F
Non-monitored converter, style 1 SJO jacketed cord set	1	1	SPAS00024-L1J
Non-monitored converter, 2-con style 6 cord sets	1	1	SPAS00024-L23
Non-monitored converter, 2-con 3-pole cord sets	1	1	SPAS00024-L2F
Non-monitored converter, 2-con style 1 SJO jacketed cord sets	1	1	SPAS00024-L2J
Buy American Preference non-monitored converter, style 6 cord set	1	1	SPAS00024-S13
Buy American Preference non-monitored converter, style 1 SJO jacketed cord set	1	1	SPAS00024-S1J
Monitored converter, style 6 cord set	1	1	SPAS00024-M13
Monitored converter, 3-pole cord set	1	1	SPAS00024-M1F
Monitored converter, style 1 SJO jacketed cord set	1	1	SPAS00024-M1J
Monitored converter, 2-con style 6 cord sets	1	1	SPAS00024-M23
Monitored converter, 2-con 3-pole cord sets	1	1	SPAS00024-M2F
Monitored converter, 2-con style 1 SJO jacketed cord sets	1	1	SPAS00024-M2J
EQ converter, style 6 cord set	1	1	SPAS00024-R13
EQ converter, 3-pole cord set	1	1	SPAS00024-R1F
EQ converter, style 1 SJO jacketed cord set	1	1	SPAS00024-R1J

Cordsets	Quantity per		spare part code
	fitting	spare part	
Cord set, L-823 style 1, 8" bottom pan, package of 5	1 or 2	5	SP.73A0193/1
Cord set, L-823 style 1, 12" bottom pan, package of 5	1 or 2	5	SP.73A0194/1
Cord set, L-823 style 6, 8" & 12" bottom pan, package of 5	1 or 2	5	SPSGE96253351
Cord set, 3-pole, 8" & 12" bottom pan, package of 5	1 or 2	5	SPSGEFR500160
Cable retaining clamp, for use with style 1 cord set, package of 5	1 or 2	5	SP.MB00003-013-01
Ground lug kit, package of 5	1	5	SP.72A0401

Prism spares	Quantity per		spare part code
	fitting	spare part	
Prism kit, runway standard, package of 2	1 or 2	2	SP.MG00001-G00-03
Prism kit, runway reinforced, package of 2	1 or 2	2	SP.MG00001-S00-03
Prism gasket, Runway, package of 10	1 or 2	10	SP.MS00004-000-02

Screws & gaskets	Quantity per		spare part code
	fitting	spare part	
Pressure release screw with o-ring, package of 5	1	5	SP.MF00090-000-01
Gasket, 12" Bottom pan, package of 10	1	10	SP.MS00006-000-01
Screws, light engine assembly mounting, package of 100	-	100	SP.MFPM4PT-710-01
Screws, 12" Bottom pan, package of 100	-	100	SP.MFPM6PT-720-01

Heater kits	Quantity per		spare part code
	fitting	spare part	
Heater kit with harness - non-monitored (S-BAP) & EQ, package of 2	1 or 2	2	SP.EP00038-R00-01
Heater kit with harness - non-monitored (S-non-BAP) & monitored, package of 2	1 or 2	2	SP.EP00038-R01-01

Wire harness	Quantity per		spare part code
	fitting	spare part	
Wire harness, power supply to light engine, package of 10	1 or 2	10	SP.EW00079-000-01

Fuse	Quantity per		spare part code
	fitting	spare part	
Fuse Resistors (only for fixtures with monitoring (M))	1 or 2	20	6132.00.250



Note

All screws for fastening are included.

Component availability or design may be subject to change due to unforeseen circumstances. This document is subject to change or new information from ADB SAFEGATE, as and when available or if required, with reservation for error or price changes.

For more information or assistance with ordering spare parts, contact ADB SAFEGATE, see www.adbsafegate.com.

7.6 Spare Parts - L- 850D(L) Threshold,Threshold/End FAA, Runway End (ICAO & FAA)



Note

- Each Top Cover Assembly includes a Bottom Cover Gasket and a Bottom Cover Screws.
- BAP stands for "Buy American Preference".

A2 - Top Cover assemblies, 12", with heater	Quantity per		spare part code
	fitting	spare part	
Unidirectional, standard prism, non-monitored (S-BAP) and EQ (R)	1	1	SPAS00018-UAG
Unidirectional, reinforced prism, non-monitored (S-BAP) and EQ (R)	1	1	SPAS00018-UAS
Unidirectional, standard prism, non-monitored (S-non-BAP) and monitored (M)	1	1	SPAS00018-UBG
Unidirectional, reinforced prism, non-monitored (S-non-BAP) and monitored (M)	1	1	SPAS00018-UBS
Bidirectional, standard prism, non-monitored (S-BAP) and EQ (R)	1	1	SPAS00018-BAG
Bidirectional, reinforced prism, non-monitored (S-BAP) and EQ (R)	1	1	SPAS00018-BAS
Bidirectional, standard prism, non-monitored (S-non-BAP) and monitored (M)	1	1	SPAS00018-BBG
Bidirectional, reinforced prism, non-monitored (S-non-BAP) and monitored (M)	1	1	SPAS00018-BBS

A2 -Top Cover assemblies, 12", no heater	Quantity per		spare part code
	fitting	spare part	
Unidirectional, standard prism	1	1	SPAS00018-UNG
Unidirectional, reinforced prism	1	1	SPAS00018-UNS
Bidirectional, standard prism	1	1	SPAS00018-BNG
Bidirectional, reinforced prism	1	1	SPAS00018-BNS

B - Light engine assembly, 12"	Quantity per		spare part code
	fitting	spare part	
FAA L-850D(L), F-green, left toe	1	1	SPAS00023-LF2-RT
FAA L-850D(L), F-green, straight	1	1	SPAS00023-SF2
FAA L-850D(L), F-green, right toe	1	1	SPAS00023-RF2-RT
Runway End, FAA L - 850D(L), red, straight	1	1	SPAS00023-SR3

C - Bottom pan assembly, 12"	Quantity per		spare part code
	fitting	spare part	
Non-monitored converter, style 6 cord set	1	1	SPAS00024-L13
Non-monitored converter, style 1 SJO jacketed cord set	1	1	SPAS00024-L1J
Non-monitored converter, 2-con style 6 cord sets	1	1	SPAS00024-L23
Non-monitored converter, 2-con style 1 SJO jacketed cord sets	1	1	SPAS00024-L2J
Buy American Preference non-monitored converter, style 6 cord set	1	1	SPAS00024-S13

C - Bottom pan assembly, 12"	Quantity per		spare part code
	fitting	spare part	
Buy American Preference non-monitored converter, style 1 so cord set	1	1	SPAS00024-S1J
Monitored converter, style 6 cord set	1	1	SPAS00024-M13
Monitored converter, style 1 SJO jacketed cord set	1	1	SPAS00024-M1J
Monitored converter, 2-con style 6 cord sets	1	1	SPAS00024-M23
Monitored converter, 2-con style 1 SJO jacketed cord sets	1	1	SPAS00024-M2J
EQ converter, style 6 cord set	1	1	SPAS00024-R13
EQ converter, style 1 SJO jacketed cord set	1	1	SPAS00024-R1J

Cordsets	Quantity per		spare part code
	fitting	spare part	
Cord set, L-823 style 1, 8" bottom pan	1 or 2	5	SP.73A0193/1
Cord set, L-823 style 1, 12" bottom pan	1 or 2	5	SP.73A0194/1
Cord set, L-823 style 6, 8" & 12" bottom pan	1 or 2	5	SP.73A0136/18
Cable retaining clamp, for use with style 1 cord set	1 or 2	5	SPMB00003-013-01
Ground lug kit	1	5	SP.72A0401

Prism spares	Quantity per		spare part code
	fitting	spare part	
Prism kit, runway standard	1 or 2	2	SPMG00001-G00-03
Prism kit, runway reinforced	1 or 2	2	SPMG00001-S00-03
Prism gasket, Runway	1 or 2	10	SPMS00004-000-02

Screws & gaskets	Quantity per		spare part code
	fitting	spare part	
Pressure release screw with o-ring	1	5	SPMF00090-000-01
Gasket, 12" Bottom pan	1	10	SPMS00006-000-01
Screws, light engine assembly mounting	-	100	SPMFPM4PT-710-01
Screws, 12" Bottom pan	-	100	SPMFPM6PT-720-01

Heater kits	Quantity per		spare part code
	fitting	spare part	
Heater kit with harness - non-monitored (S-BAP) & EQ	1 or 2	2	SPEP00038-R00-01
Heater kit with harness -monitored	1 or 2	2	SPEP00038-R01-01

Wire harness	Quantity per		spare part code
	fitting	spare part	
Wire harness, power supply to light engine	1 or 2	10	SPEW00079-000-01

Fuse	Quantity per		spare part code
	fitting	spare part	
Fuse Resistors (only for fixtures with monitoring (M))	1 or 2	20	6132.00.250



Note

All screws for fastening are included.

Component availability or design may be subject to change due to unforeseen circumstances. This document is subject to change or new information from ADB SAFEGATE, as and when available or if required, with reservation for error or price changes.

For more information or assistance with ordering spare parts, contact ADB SAFEGATE, see www.adbsafegate.com.

7.7 Spare Parts - Takeoff/Hold & Runway Intersection, L-850T(L) (ICAO & FAA)



Note

- Each Top Cover Assembly includes a Bottom Cover Gasket and a Bottom Cover Screws.
- BAP stands for "Buy American Preference".

A1 - Top Cover assemblies (2-bolt), 8", with heater	Quantity per		spare part code
	fitting	spare part	
Unidirectional, standard prism, EQ (R)	1	1	SPAS00019-3AG
Unidirectional, reinforced prism, EQ (R)	1	1	SPAS00019-3AS
Unidirectional, standard prism, monitored (M)	1	1	SPAS00019-3BG
Unidirectional, reinforced prism, monitored (M)	1	1	SPAS00019-3BS

A1 - Top Cover assemblies (2-bolt), 8", no heater	Quantity per		spare part code
	fitting	spare part	
Unidirectional, standard prism	1	1	SPAS00019-3NG
Unidirectional, reinforced prism	1	1	SPAS00019-3NS

A1 - Top Cover assemblies (4-bolt), 8", with heater	Quantity per		spare part code
	fitting	spare part	
Unidirectional, standard prism, EQ (R)	1	1	SPAS00019-5AG
Unidirectional, reinforced prism, EQ (R)	1	1	SPAS00019-5AS
Unidirectional, standard prism, monitored (M)	1	1	SPAS00019-5BG
Unidirectional, reinforced prism, monitored (M)	1	1	SPAS00019-5BS

A1 - Top Cover assemblies (4-bolt), 8", no heater	Quantity per		spare part code
	fitting	spare part	
4-bolt unidirectional, standard prism	1	1	SPAS00019-5NG
4-bolt unidirectional, reinforced prism	1	1	SPAS00019-5NS

A2 - Top Cover assemblies, 12", with heater	Quantity per		spare part code
	fitting	spare part	
Unidirectional, standard prism, EQ (R)	1	1	SPAS00018-UAG
Unidirectional, reinforced prism, EQ (R)	1	1	SPAS00018-UAS
Unidirectional, standard prism, monitored (M)	1	1	SPAS00018-UBG
Unidirectional, reinforced prism, monitored (M)	1	1	SPAS00018-UBS

A2 - Top Cover assemblies, 12", no heater	Quantity per		spare part code
	fitting	spare part	
Unidirectional, standard prism	1	1	SPAS00018-UNG
Unidirectional, reinforced prism	1	1	SPAS00018-UNS

B1 - Light engine assembly	Quantity per		spare part code
	fitting	spare part	
Take-off/Hold light, FAA L-850T(L) 12", red	1	1	SPAS00023-SR2
Take-off/Hold light, FAA L-850T(L) 8", red	1	1	SPAS00020-SR2

C - Bottom pan assembly, 8"	Quantity per		spare part code
	fitting	spare part	
Monitored converter, style 6 cord set	1	1	SPAS00021-M13
Monitored converter, style 1 SJO jacketed cord set	1	1	SPAS00021-M1J
RWSL EQ converter, style 6 cord set	1	1	SPAS00021-R13
RWSL EQ converter, style 1 SJO jacketed cord set	1	1	SPAS00021-R1R

C - Bottom pan assembly, 12"	Quantity per		spare part code
	fitting	spare part	
Monitored converter, style 6 cord set	1	1	SPAS00021-M13
Monitored converter, style 1 SJO jacketed cord set	1	1	SPAS00021-M1J
RWSL EQ converter, style 6 cord set	1	1	SPAS00021-R13
RWSL EQ converter, style 1 SJO jacketed cord set	1	1	SPAS00021-R1R

Cordsets	Quantity per		spare part code
	fitting	spare part	
Cord set, L-823 style 1, 8" bottom pan	1	5	SP.73A0193/1
Cord set, L-823 style 1, 12" bottom pan	1	5	SP.73A0194/1
Cord set, L-823 style 6, 8" & 12" bottom pan	1	5	73A0136/18
Cable retaining clamp, for use with style 1 cord set	1	5	SP.MB00003-013-01

Prism spares	Quantity per		spare part code
	fitting	spare part	
Prism kit, runway standard	1	2	SP.MG00001-G00-03
Prism kit, runway reinforced	1	2	SP.MG00001-S00-03
Prism gasket, Runway	1	10	SP.MS00004-000-02

Screws & gaskets	Quantity per		spare part code
	fitting	spare part	
Pressure release screw with o-ring	1	5	SP.MF00090-000-01
Gasket, 8" Bottom pan	1	10	SP.MS00005-000-01
Screws, 8" Bottom pan	-	100	SP.MFPM5PT-714-01
Gasket, 12" Bottom pan	1	10	SP.MS00006-000-01
Screws, light engine assembly mounting	-	100	SP.MFPM4PT-710-01
Screws, 12" Bottom pan	-	100	SP.MFPM6PT-720-01

Heater kits	Quantity per		spare part code
	fitting	spare part	
Heater kit with harness - non-monitored (S-BAP) & EQ	1	2	SPEP00038-R00-01
Heater kit with harness - monitored	1	2	SPEP00038-R01-01

Wire harness	Quantity per		spare part code
	fitting	spare part	
Wire harness, power supply to light engine	1	10	SPEW00079-000-01

Fuse	Quantity per		spare part code
	fitting	spare part	
Fuse Resistors (only for fixtures with monitoring (M))	1	20	6132.00.250



Note

All screws for fastening are included.

Component availability or design may be subject to change due to unforeseen circumstances. This document is subject to change or new information from ADB SAFEGATE, as and when available or if required, with reservation for error or price changes.

For more information or assistance with ordering spare parts, contact ADB SAFEGATE, see www.adbsafegate.com.

7.8 Spare Parts - Runway Guard Light, L - 852G(L) (ICAO & FAA)



NOTICE

- Each Top Cover Assembly includes a Bottom Cover Gasket and a Bottom Cover Screws.
- BAP stands for "Buy American Preference".

A1 - Top cover assemblies, (4-bolt) 8", with heater	Quantity per		Order code
	fitting	order	
Unidirectional, standard prism, non-monitored (S-BAP) and EQ (R)	1	1	SPAS00019-5AG
Unidirectional, reinforced prism, non-monitored (S-BAP) and EQ (R)	1	1	SPAS00019-5AS
Unidirectional, standard prism, non-monitored (S-non-BAP) and monitored (M)	1	1	SPAS00019-5BG
Unidirectional, reinforced prism, non-monitored (S-non-BAP) and monitored (M)	1	1	SPAS00019-5BS
Bidirectional, standard prism, non-monitored (S-BAP) and EQ (R)	1	1	SPAS00019-6AG
Bidirectional, reinforced prism, non-monitored (S-BAP) and EQ (R)	1	1	SPAS00019-6AS
Bidirectional, standard prism, non-monitored (S-non-BAP) and monitored (M)	1	1	SPAS00019-6BG
Bidirectional, reinforced prism, non-monitored (S-non-BAP) and monitored (M)	1	1	SPAS00019-6BS

A1 - Top cover assemblies, (4-bolt) 8", no heater	Quantity per		Order code
	fitting	order	
Unidirectional, standard prism	1	1	SPAS00019-5NG
Unidirectional, reinforced prism	1	1	SPAS00019-5NS
Bidirectional, standard prism	1	1	SPAS00019-6NG
Bidirectional, reinforced prism	1	1	SPAS00019-6NS

A1 - Top cover assemblies, (2-bolt) 8", with heater	Quantity per		Order code
	fitting	order	
Unidirectional, standard prism, non-monitored (S-BAP) and EQ (R)	1	1	SPAS00019-3AG
Unidirectional, reinforced prism, non-monitored (S-BAP) and EQ (R)	1	1	SPAS00019-3AS
Unidirectional, standard prism, non-monitored (S-non-BAP) and monitored (M)	1	1	SPAS00019-3BG
Unidirectional, reinforced prism, non-monitored (S-non-BAP) and monitored (M)	1	1	SPAS00019-3BS
Bidirectional, standard prism, non-monitored (S-BAP) and EQ (R)	1	1	SPAS00019-4AG
Bidirectional, reinforced prism, non-monitored (S-BAP) and EQ (R)	1	1	SPAS00019-4AS
Bidirectional, standard prism, non-monitored (S-non-BAP) and monitored (M)	1	1	SPAS00019-4BG
Bidirectional, reinforced prism, non-monitored (S-non-BAP) and monitored (M)	1	1	SPAS00019-4BS

A1 - Top cover assemblies, (2-bolt) 8", no heater	Quantity per		Order code
	fitting	order	
Unidirectional, standard prism	1	1	SPAS00019-3NG
Unidirectional, reinforced prism	1	1	SPAS00019-3NS
Bidirectional, standard prism	1	1	SPAS00019-4NG
Bidirectional, reinforced prism	1	1	SPAS00019-4N

A2 - Top cover assemblies, 12-inch, with heater	Quantity per		Order code
	fitting	order	
Unidirectional, standard prism, non-monitored (S-BAP) and EQ (R)	1	1	SPAS00018-UAG
Unidirectional, reinforced prism, non-monitored (S-BAP) and EQ (R)	1	1	SPAS00018-UAS
Unidirectional, standard prism, non-monitored (S-non-BAP) and monitored (M)	1	1	SPAS00018-UBG
Unidirectional, reinforced prism, non-monitored (S-non-BAP) and monitored (M)	1	1	SPAS00018-UBS
Bidirectional, standard prism, non-monitored (S-BAP) and EQ (R)	1	1	SPAS00018-BAG
Bidirectional, reinforced prism, non-monitored (S-BAP) and EQ (R)	1	1	SPAS00018-BAS
Bidirectional, standard prism, non-monitored (S-non-BAP) and monitored (M)	1	1	SPAS00018-BBG
Bidirectional, reinforced prism, non-monitored (S-non-BAP) and monitored (M)	1	1	SPAS00018-BBS

A2 - Top cover assemblies, 12-inch, no heater	Quantity per		Order code
	fitting	order	
Unidirectional, standard prism	1	1	SPAS00018-UNG
Unidirectional, reinforced prism	1	1	SPAS00018-UNS
Bidirectional, standard prism	1	1	SPAS00018-BNG
Bidirectional, reinforced prism	1	1	SPAS00018-BNS

B1 - Light engine assembly, 8"	Quantity per		Order code
	fitting	order	
Runway Guard Light, FAA L-852G(L), Yellow	1	1	SPAS00020-GY2
Runway Guard Light, FAA L-852G(L) IR Sensor Optic (Autonomous version)	1	1	SPAS00277-008

B1 - Light engine assembly, 12"	Quantity per		Order code
	fitting	order	
Runway Guard Light, FAA L-852G(L), Yellow	1	1	SPAS00023-GY2
Runway Guard Light, FAA L-852G(L) IR Sensor Optic (Autonomous version)	1	1	SPAS00277-012

AXON Runway Inset Lights, 8-inch and 12-inch
Spare Parts

C - Bottom pan assembly, 8"	Quantity per		Order code
	fitting	order	
Non-monitored converter, style 6 cord set	1	1	SPAS00021-L13
Non-monitored converter, 3-pole cord set	1	1	SPAS00021-L1F
Non-monitored converter, style 1 SJO jacketed cord set	1	1	SPAS00021-L1J
Buy American Preference non-monitored converter, style 6 cord set	1	1	SPAS00021-S13
Buy American Preference non-monitored converter, style 1 SJO jacketed cord set	1	1	SPAS00021-S1J
Monitored converter, style 6 cord set	1	1	SPAS00021-M13
monitored converter, 3-pole cord set	1	1	SPAS00021-M1F
monitored converter, style 1 SJO jacketed cord set	1	1	SPAS00021-M1J
EQ converter, style 6 cord set	1	1	SPAS00021-R13
EQ converter, 3-pole cord set	1	1	SPAS00021-R1F
EQ converter, style 1 SJO jacketed cord set	1	1	SPAS00021-R1J

C - Bottom pan assemblies, 12"	Quantity per		Order code
	fitting	order	
Non-monitored converter, style 6 cord set	1	1	SPAS00024-L13
Non-monitored converter, 3-pole cord set	1	1	SPAS00024-L1F
Non-monitored converter, style 1 SJO jacketed cord set	1	1	SPAS00024-L1J
Buy American Preference non-monitored converter, style 6 cord set	1	1	SPAS00024-S13
Buy American Preference non-monitored converter, style 1 SJO jacketed cord set	1	1	SPAS00024-S1J
Monitored converter, style 6 cord set	1	1	SPAS00024-M13
Monitored converter, 3-pole cord set	1	1	SPAS00024-M1F
Monitored converter, style 1 SJO jacketed cord set	1	1	SPAS00024-M1J
EQ converter, style 6 cord set	1	1	SPAS00024-R13
EQ converter, 3-pole cord set	1	1	SPAS00024-R1F
EQ converter, style 1 SJO jacketed cord set	1	1	SPAS00024-R1J

Cord set	Quantity per		Order code
	fitting	order	
Cord set, L-823 style 1, 8" bottom pan	1	5	SP.73A0193/1
Cord set, L-823 style 1, 12" bottom pan	1	5	SP.73A0194/1
Cord set, L-823 style 6, 8" & 12" bottom pan	1	5	SP.73A0136/18
Cord set, 3-pole, 8" & 12" bottom pan	1	5	SP.SGFR500160
Cable retaining clamp, for use with style 1 cord set	1	5	SP.MB00003-013-01
Ground lug kit	1	5	SP.72A0401

Prism spares	Quantity per		Order code
	fitting	order	
Prism kit, runway standard	1 or 2	2	SPMG00001-G00-03
Prism kit, runway reinforced	1 or 2	2	SPMG00001-S00-03
Prism gasket, Runway	1 or 2	10	SPMS00004-000-02

Screws & gaskets	Quantity per		Order code
	fitting	order	
Pressure release screw with o-ring	1	5	SPMF00090-000-01
Gasket, 8" Bottom pan	1	10	SPMS00005-000-01
Screws, 8" Bottom pan	-	100	SPMFPM5PT-714-01
Gasket, 12" Bottom pan	1	10	SPMS00006-000-01
Screws, light engine assembly mounting	-	100	SPMFPM4PT-710-01
Screws, 12" Bottom pan	-	100	SPMFPM6PT-720-01

Heater kits	Quantity per		Order code
	fitting	order	
Heater kit with harness - non-monitored (S-BAP) & EQ	1	2	SP.EP00038-R00-01
Heater kit with harness - non-monitored (S-non-BAP) & monitored	1	2	SP.EP00038-R01-01

Wire harness	Quantity per		Order code
	fitting	order	
Wire harness, power supply to light engine, 8" fixture	1	10	SPEW00079-150-01
Wire harness, power supply to light engine, 12" fixture	1	10	SPEW00079-300-01

Fuse	Quantity per		Order code
	fitting	order	
Fuse Resistors (only for fixtures with monitoring (M))	1	20	6132.00.250



Note

All screws for fastening are included.

Component availability or design may be subject to change due to unforeseen circumstances. This document is subject to change or new information from ADB SAFEGATE, as and when available or if required, with reservation for error or price changes.

For more information or assistance with ordering spare parts, contact ADB SAFEGATE, see www.adbsafegate.com.

8.0 INTEROPERABILITY

Base installation – O-ring selection and retaining bolts 12-inch

For 12-inch light fixtures the O-ring is required. Refer to data sheet for ordering code for corresponding 12-inch base.



CAUTION

Use of incorrect combination of gaskets, bolts and nuts can create severe damages to the product installation and create multiple safety risks.

To obtain a safe and watertight installation the O-ring and retaining bolt stated in the document must be used.

You need to know what base the light fixture will be installed in, in order to choose the correct gasket, bolts and nuts.

Failure to follow these cautions can result in equipment damage or aircraft FOD.

Table 1: Interoperability matrix — 12 inch

Base type	Required O-ring	Bolt installation	Stud installation		Recommended torque
		Required dimension	Recommended torque	Required nut	
RELIANCE 12" 150 mm Safegate 12" 150 mm ERNI 12" ED12-190	O-ring D259, 3×5, 7 SP013114/10pc SP013115/100pc	1411.20.482 Metric screw kit 12" M10×25 mm	40 Nm+locking washer (max height 2 mm)	1411.20.500 Self-locking nut kit 12" M10xH=100	35 Nm
Thorn 12" 150 mm Thorn 12" 100mm	O-ring D259, 3×5, 7 SP013114/10pc SP013115/100pc	1411.20.482 Metric screw kit 12" M10×25 mm	40 Nm+locking washer (max height 2 mm) *only with non-roll over lights	1411.20.500 Self-locking nut kit 12" M10xH=100	35 Nm *only with non-roll over lights
L-868 deep can with flange	O-ring D259, 3×5, 7 SP013114/10pc SP013115/100pc	1411.20.452 UNC screw kit	reference EB83	NA	NA
ADB 12" Eurobase	O-ring D259, 3×5, 7 SP013114/10pc SP013115/100pc	1411.22.482 Metric screw kit 12" M10×22 mm	21 Nm + Loctite 2701 or 638	1411.20.500 Self-locking nut kit 12" M10xH=100	21 Nm Do not use Loctite or washer with self- locking nut

Table 2: Interoperability matrix — 8 inch

 Note Base type	Required O-ring	Bolt installation		Stud installation	
		Required dimension	Recommended torque ¹	Required nut	Recommended torque ¹
RELIANCE BASE 8" 135 mm	Red O-Ring SGE.SP24523/10 pc SGE.SP24526/100 pc	1411.20.522 Metric screw kit 8" M10x25mm	40 Nm+locking washer (max height 2 mm)	1411.20.430 Self-locking nut kit 8" M10xH100	35 Nm
ERNI 8" EE08 150 mm ERNI 8" ED08 133 mm	Blue O-Ring SGE.SP24521/10 pc SGE.SP24524/100 pc	1411.20.522 Metric screw kit 8" M10x25 mm	40 Nm+locking washer (max height 2 mm)	1411.20.430 Self- locking nut kit 8" M10xH100	35 Nm
Thorn 8" 100 mm Thorn 8" 133 mm IDM 6494 120 mm	Red O-Ring SGE.SP24523/10 pc SGE.SP24526/100 pc	1411.20.522 Metric screw kit 8" M10x25 mm	40 Nm+locking washer (max height 2 mm)	1411.20.430 Self-locking nut kit 8" M10xH100	35 Nm
ADB 8" Eurobase	Blue O-Ring SGE.SP24521/10 pc SGE.SP24524/100 pc	1411.20.522 Metric screw kit 8" M10x25 mm	21 Nm+Loctite 2701 or 638	1411.20.430 Self-locking nut kit 8" M10xH100	21 Nm No Loctite to be used on Self- locking nut nor a washer
ADB 8" HPI	Grey O-Ring SGE.SP24522/10 pc SGE.SP24525/100 pc	1411.20.522 Metric screw kit 8" M10x25 mm	21 Nm+Loctite 2701 or 638	1411.20.430 Self-locking nut kit 8" M10xH100	21 Nm No Loctite to be used on Self- locking nut nor a washer
Adapter ring ADB 8"-12"	Blue O-Ring SGE.SP24521/10 pc SGE.SP24524/100 pc	1411.20.522 Metric screw kit 8" M10x25 mm	21 Nm+Loctite 2701 or 638	1411.20.430 Self-locking nut kit 8" M10xH100	21 Nm No Loctite to be used on Self- locking nut nor a washer
Adapter ring SG/ Thorn/ID 8"-12"	Red O-Ring SGE.SP24523/10 pc SGE.SP24526/100 pc	1411.20.522 Metric screw kit 8" M10x25 mm	40 Nm+locking washer (max height 2 mm)	1411.20.430 Self-locking nut kit 8" M10xH100	35 Nm

¹ Do not use SO jacketed cord Style 1



Appendix A: POWER TABLE

LED L-850A(L), L-850B(L) Runway Centerline and Touchdown Zone

8-inch and 12-inch light fixtures **without** Arctic Kit (heater)

Fixture type – 1 cord set ¹	Fixture load	Isolation transformer		CCR load
		Wattage	Load	
Runway Centerline, L-850A(L), bidirectional	34.9 VA	45 W	14.2 VA	49.1 VA
Touchdown Zone, L-850B(L), unidirectional	25.5 VA	25 W	7.2 VA	32.7 VA

8-inch and 12-inch light fixtures **with** Arctic Kit (heater)

Fixture Types – 1 cord set ¹	Fixture load	Isolation transformer		CCR load
		Wattage	Load	
Runway Centerline, L-850A(L), bidirectional	62.6 VA	65 W	16.6 VA	79.2 VA
Touchdown Zone, L-850B(L), unidirectional	48.8 VA	45 W	9.7 VA	58.5 VA

Notes

¹ Values provided are for the "S" option non-monitored power only.

LED L-850C(L) Runway Edge 45 m

12-inch light fixtures **without** Arctic Kit (heater)

Fixture type – 1 cord set ¹	Fixture load	Isolation transformer		CCR load
		Wattage	Load	
Runway Edge, L-850C(L), bidirectional	60.7 VA	65 W	17.4 VA	78.1 VA

12-inch light fixtures **with** Arctic Kit (heater)

Fixture type – 1 cord set ¹	Fixture load	Isolation transformer		CCR load
		Wattage	Load	
Runway Edge, L-850C(L), bidirectional	71.6 VA	65 W	15.7 VA	87.3 VA

Notes

¹ Values provided are for the "S" option non-monitored power only.

LED L-850D(L) Runway Threshold, End, Threshold/End

12-inch light fixtures **without** Arctic Kit (heater)

Fixture type – 1 cord set ¹	Fixture load	Isolation transformer		CCR load
		Wattage	Load	
Runway Threshold, L-850D(L), bidirectional, F-Green/red	36.6 VA	45 W	14.2 VA	50.8 VA
Runway Threshold, L-850D(L), bidirectional, red/red	46.6 VA	45 W	13 VA	59.6 VA
Runway Threshold, L-850D(L), unidirectional, F-Green	21.2 VA	25 W	6.8 VA	28 VA
Runway Threshold, L-850D(L), unidirectional, red	31.6 VA	25 W	9.5 VA	41.1 VA

12-inch light fixtures **with** Arctic Kit (heater)

Fixture type – 1 cord set ¹	Fixture load	Isolation transformer		CCR load
		Wattage	Load	
Runway Threshold, bidirectional, L-850D(L), F-Green/red	65.3 VA	65 W	16.2 VA	81.5 VA
Runway Threshold, L-850D(L), unidirectional, F-Green	49.4 VA	45 W	10 VA	59.4 VA

Notes

¹ Values provided are for the "S" option non-monitored power only.

LED ICAO Runway Threshold, END, Threshold/End

12-inch light fixtures **without** Arctic Kit (without heater)

Fixture type – 1 cord set ¹	Fixture load	Isolation transformer		CCR load
		Wattage	Load	
Threshold/End	43 VA	45 W	12 VA	55 VA
End/End	32 VA	45 W	9 VA	41 VA
Threshold	32 VA	45 W	9 VA	41 VA
End	19 VA	25 W	6 VA	25 VA

Notes

¹ Values provided are for the "S" option non-monitored power only.

LED Runway Status L-850T(L), Takeoff/Hold, Runway Intersection (THL/RIL) and Runway Entry Light (REL)

8- and 12-inch light fixtures **without** Arctic Kit

Fixture type – 1 cord set	Fixture load	Isolation transformer		CCR load
		Wattage	Load	
L-850T(L) THL/RIL Takeoff Hold Light	16.5 VA	25 W	10 VA	26.5 VA
REL Runway Entry Light	17.5 VA	25 W	9.8 VA	27.3 VA

8- and 12-inch light fixtures **with** Arctic Kit

Fixture type – 1 cord set	Fixture load	Isolation transformer		CCR load
		Wattage	Load	
L-850T(L) THL/RIL Takeoff Hold Light	48.5 VA	65 W	14 VA	62.5 VA
REL Runway Entry Light	49.5 VA	65 W	14 VA	63.5 VA

LED Stopway , ≤ 45 m Width

12-inch light fixtures **without** Arctic Kit (without heater)

Fixture type – 1 cord set	Fixture load	Isolation transformer		CCR load
		Wattage	Load	
Stopway Unidirectional	34.9VA	45W	14.2VA	49.1VA

LED RETIL

8- and 12-inch light fixtures **without** Arctic Kit

Fixture type – 1 cord set ¹	Fixture load	Isolation transformer		CCR load
		Wattage	Load	
RETIL	25.5 VA	25 W	7.2 VA	32.7 VA

Notes

¹ Values provided are for the "M" option monitored power supply

LED Runway Guard Light, L-852G(L)

8 and 12-inch light fixtures **without** Arctic Kit (heater)

Fixture type – 1 cord set	Fixture load	Isolation transformer		CCR load
		Wattage	Load	
Runway Guard Light, L-852(L), Autonomous	26 VA	25 W	8 VA	34 VA
Runway Guard Light, L-852(L), EQ / LINC 360	28 VA	45 W	10 VA	38 VA

8 and 12-inch light fixtures **with** Arctic Kit (heater)

Fixture type – 1 cord set	Fixture load	Isolation transformer		CCR load
		Wattage	Load	
Runway Guard Light, L-852(L), Autonomous	43 VA	45 W	9 VA	52 VA
Runway Guard Light, L-852(L), EQ / LINC 360	45 VA	45 W	9 VA	54 VA

Appendix B: CABLE LOSS

The cable resistance R (ohms) for 1 conductor is calculated with following formula:

- $R \text{ (ohms)} = \text{resistivity of material (ohm m)} \times \text{length (m)} / \text{cross sectional area (m}^2\text{)}$
- For copper conductors the resistivity is $1.72 \cdot 10^{-8} \text{ (m}^2\text{)}$

Example; for 1 km 2.5 mm^2 copper conductor, the resistance R is calculated as follows:

$$1.72 \cdot 10^{-8} \times 1000 / 2.5 \cdot 10^{-6} \text{ m}^2 = 6.88 \text{ ohms}$$

The loss (Watt) is then $R \times I^2$ or $6.88 \text{ ohms} \times 6.6^2 \text{ A}^2 = 299.69 \text{ W/km}$ or 0.299 W/m .

The loss (Watt) for a secondary cable with 2 conductors is thus $2 \times 0.299 = 0.599$ or 0.6 W/m .

As such we can calculate:

- Secondary cable for a 2.5 mm^2 Cu-wire (2 conductors): 0.6 W/m
- Secondary cable for a 4 mm^2 Cu-wire (2 conductors): 0.4 W/m
- Primary cable for a 6 mm^2 Cu-wire (1 conductor): 0.12 W/m

The cable between the isolation transformer and the lamp adds losses that cannot be ignored when dimensioning the circuits and selecting rating for secondary transformers and regulators.



WARNING

Cable lengths should not exceed 100 meters.

For a secondary cable of e.g., 20 m of 2.5 mm^2 CU-wire, $20 \text{ m} \times 0.6 \text{ W/m} = 12 \text{ W}$ equals the additional loss to be taken into account.

For a primary cable of e.g., 100 m of 6 mm^2 CU-wire, $100 \text{ m} \times 0.12 \text{ W/m} = 12 \text{ W}$ equals the additional loss to be taken into account.

Appendix C: SUPPORT

Our experienced engineers are available for support and service at all times, 24 hour/7 days a week. They are part of a dynamic organization making sure the entire ADB SAFEGATE is committed to minimal disturbance for airport operations.

ADB SAFEGATE Support

Live Technical Support – Americas

If at any time you have a question or concern about your product, just contact ADB SAFEGATE's technical service department. Trained in all areas of system issues, troubleshooting, quality control and technical assistance, our highly experienced Technical support specialists are available 24 hours a day, seven days a week to provide assistance over the phone.

ADB SAFEGATE Americas Technical Service & Support (US & Canada): +1-800-545-4157

ADB SAFEGATE Americas Technical Service & Support (International): +1-614-861-1304

During regular business hours, you can also Chat with a Service Technician. We look forward to working with you!

Before You Call

When you have an airfield lighting or system control system problem, it is our goal to support airfield maintenance staff as quickly as possible. To support this effort, prior to calling, please ensure the following:

- Review the product's manual and troubleshooting guide.
- Be located with the product ready to troubleshoot.
- Have all necessary information available: airport code/company name, customer id number, contact phone number/email address, product/part number.
- Have a *True RMS* meter available and any other necessary tools.

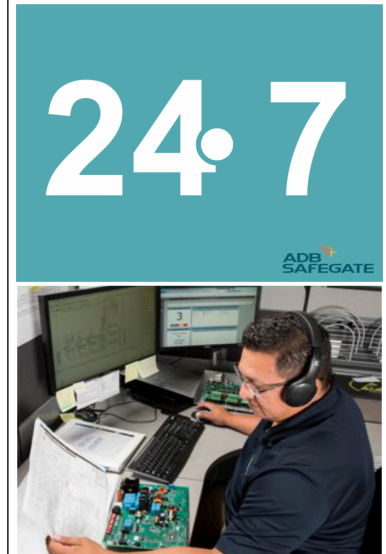

Note

For more information, see www.adbsafegate.com, or contact ADB SAFEGATE Support via email at support@adbsafegate.com or

Europe: +32 2 722 17 11

Americas: +1 614 861 1304. Press 3 for technical service or press 4 for sales support.

China: +86 (10) 8476 0106

Middle East and Africa: +971 4 452 7575

C.1 ADB SAFEGATE Website

The ADB SAFEGATE website, www.adbsafegate.com, offers information regarding our airport solutions, products, company, news, links, downloads, references, contacts and more.

C.2 Recycling

C.2.1 Local Authority Recycling

The disposal of ADB SAFEGATE products is to be made at an applicable collection point for the recycling of electrical and electronic equipment. The correct disposal of equipment prevents any potential negative consequences for the environment and human health, which could otherwise be caused by inappropriate waste handling. The recycling of materials helps to conserve natural resources. For more detailed information about recycling of products, contact your local authority city office.

C.2.2 ADB SAFEGATE Recycling

ADB SAFEGATE is fully committed to environmentally-conscious manufacturing with strict monitoring of our own processes as well as supplier components and sub-contractor operations. ADB SAFEGATE offers a recycling program for our products to all customers worldwide, whether or not the products were sold within the EU.

ADB SAFEGATE products and/or specific electrical and electronic component parts which are fully removed/separated from any customer equipment and returned will be accepted for our recycling program.

All items returned must be clearly labeled as follows:

- For *ROHS/WEEE* Recycling
- Sender contact information (Name, Business Address, Phone number).
- Main Unit Serial Number.

ADB SAFEGATE will continue to monitor and update according for any future requirements for *EU directives* as and when *EU member states* implement new *regulations* and or *amendments*. It is our aim to maintain our *compliance plan* and assist our customers.

Company Addresses

ADB SAFEGATE, Belgium	ADB SAFEGATE BV Leuvensesteenweg 585, B-1930 Zaventem Belgium
Contact: Tel.: +32 2 722 17 11 Fax: +32 2 722 17 64	Email: marketing@adbsafegate.com Internet: www.adbsafegate.com
ADB SAFEGATE, Americas	ADB SAFEGATE Americas LLC 700 science Blvd, Colombus OH 43230, USA
Contact: Tel.: +1 (614) 861 1304 Fax: +1 (614) 864 2069	Email: sales.us@adbsafegate.com Internet: www.adbsafegate.com
ADB SAFEGATE, Sweden	ADB SAFEGATE Sweden AB Djurhagegatan 19 SE-213 76 Malmö Sweden
Contact: Tel.: +46 (0)40 699 17 00 Fax: +46 (0)40 699 17 30	Email: marketing@adbsafegate.com Internet: www.adbsafegate.com
ADB SAFEGATE, China	ADB SAFEGATE Airfield Technologies Ltd. China Unit 603, D Block, CAMIC International Convention Center, No 3, Hua Jia Di East road, ChaoYang district, Beijing 100102 P.R. China
Contact: Tel.: +86 (10) 8476 0106 Fax: +86 (10) 8476 0090	Email: china@safegate.com Internet: www.adbsafegate.com
ADB SAFEGATE, Germany	ADB SAFEGATE Germany GmbH Konrad-Zuse-Ring 6, D-68163 Mannheim Germany
Contact: Tel.: +49 (621) 87 55 76-0 Fax: +49 (621) 87 55 76-55	Email: marketing@adbsafegate.com Internet: www.adbsafegate.com



Powering Your Airport Performance from Approach to Departure

adbsafegate.com

Copyright © ADB SAFEGATE, all rights reserved

