

SECTION  
 RELIANCE UNIDIRECTIONAL ELEVATED LIGHT  
 Scale 1/5

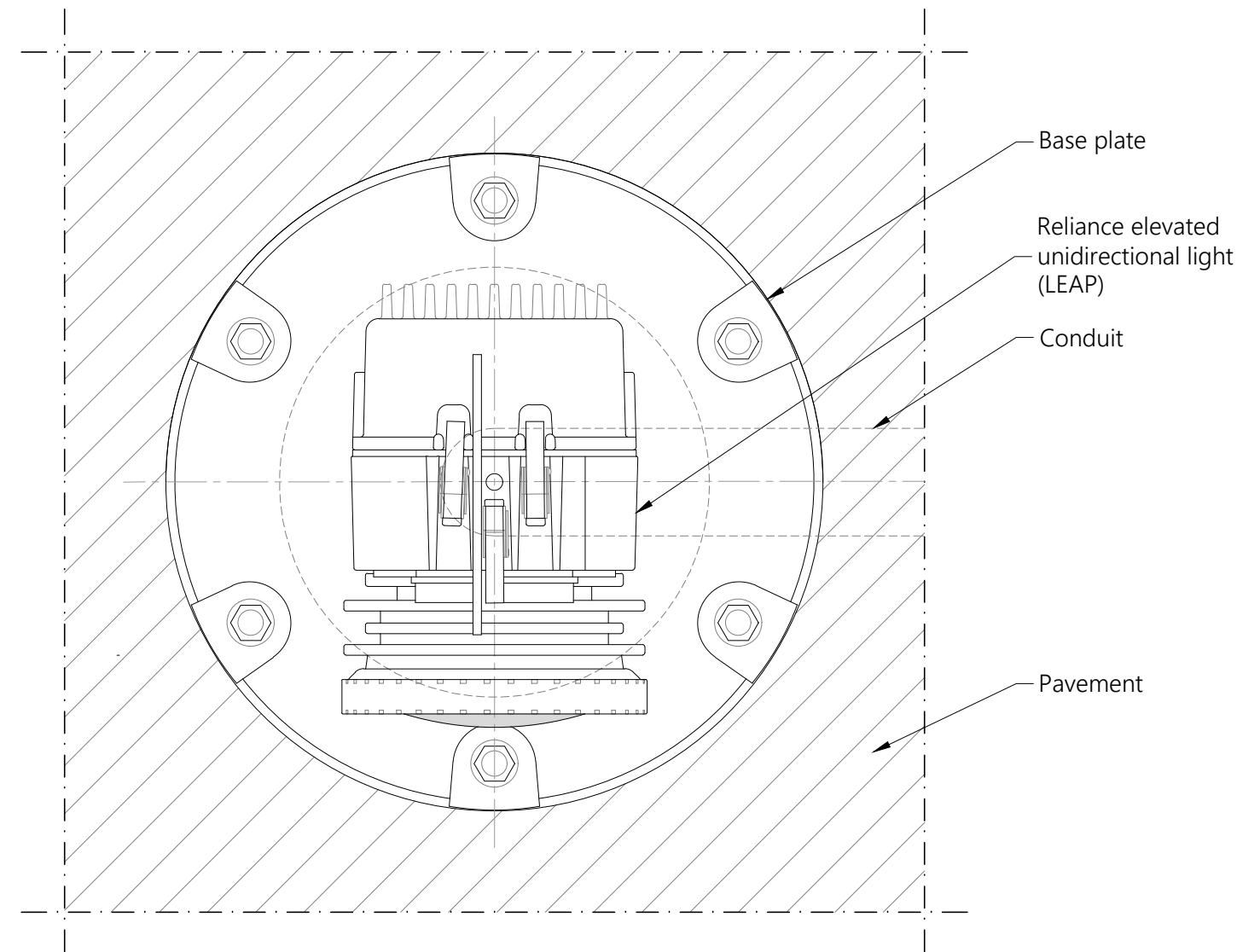

TOP VIEW  
 RELIANCE UNIDIRECTIONAL ELEVATED LIGHT  
 Scale 1/3

NOTES:

1. This drawing shows general installation details related to ADB Safegate products and is for information only, not for construction. The designer must verify compliance of design with local standards and varying characteristics for each unique airfield project.
2. Pavement types and dimensions shown are only indicative. Installation details may vary depending on project specific pavement types and dimensions.
3. Please refer to product installation manual for installation process details.
4. ADB Safegate waives its liability for wrongful use of the information.



RELIANCE LIGHT  
 (LEAP)  
 ELEVATED UNIDIRECTIONAL  
 TYPICAL INSTALLATION DETAILS

SCALE: AS SHOWN	UNIT: mm
DRAWN BY: JA	CHECKED BY: TH
DATE: 20/12/2023	SHEET: 1-2
ADBSG_A_AGL_RELIANCE-E_LEAP_Uni_01	

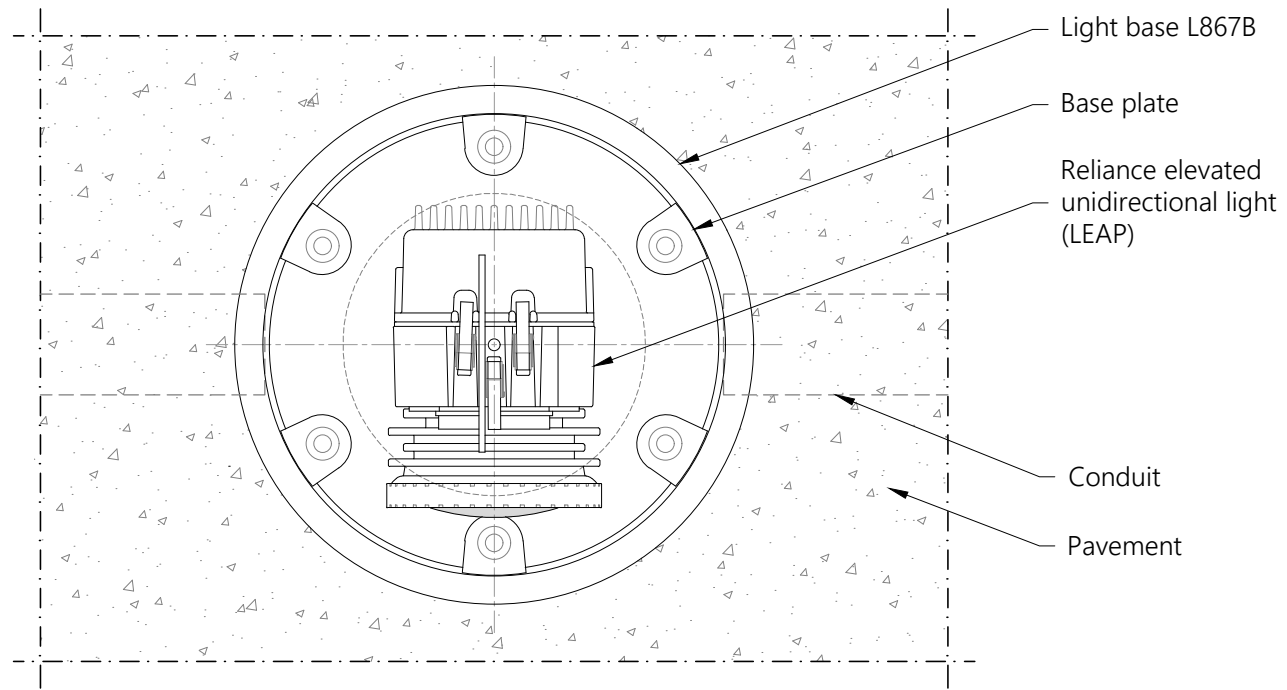

TOP VIEW  
 RELIANCE UNIDIRECTIONAL ELEVATED LIGHT  
 Scale 1/5

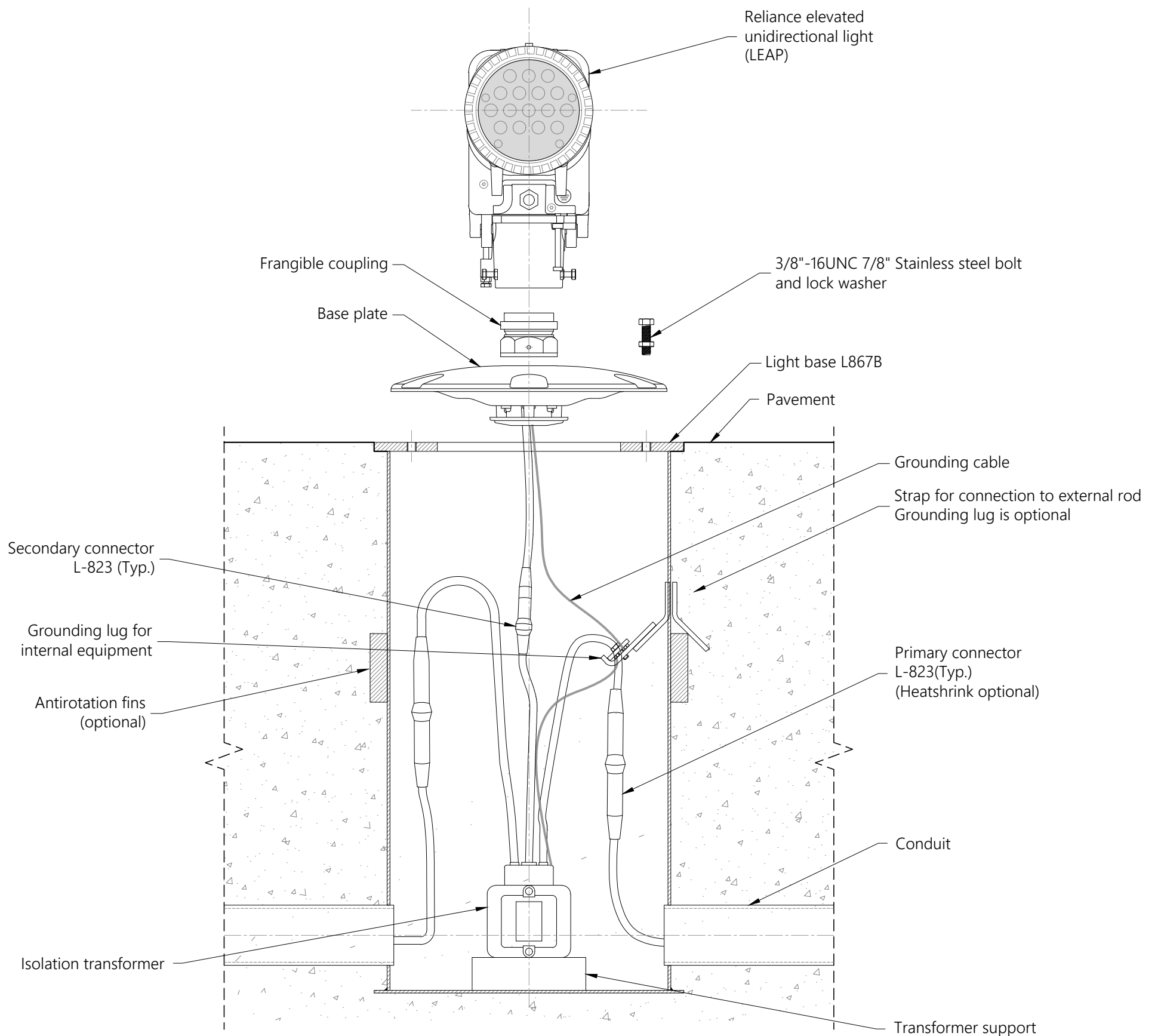

1 PIECE L-867B BASE INSTALLATION  
 RELIANCE UNIDIRECTIONAL ELEVATED LIGHT  
 Scale 1/5

NOTES:

1. This drawing shows general installation details related to ADB Safegate products and is for information only, not for construction. The designer must verify compliance of design with local standards and varying characteristics for each unique airfield project.
2. Pavement types and dimensions shown are only indicative. Installation details may vary depending on project specific pavement types and dimensions.
3. Please refer to product installation manual for installation process details.
4. ADB Safegate waives its liability for wrongful use of the information.



RELIANCE LIGHT  
 (LEAP)  
 ELEVATED UNIDIRECTIONAL  
 TYPICAL INSTALLATION DETAILS

SCALE: AS SHOWN	UNIT: mm
DRAWN BY: JA	CHECKED BY: TH
DATE: 20/12/2023	SHEET: 2-2
ADBSG_A_AGL_RELIANCE-E_LEAP_Uni_01	