



Constant Current Regulator Type VIS

User Manual

UM-6007, Rev. 2.2, 2024/07/17

**ADB
SAFEGATE**

A.0 Disclaimer / Standard Warranty

CE certification

The equipment listed as CE certified means that the product complies with the essential requirements concerning safety and hygiene. The European directives that have been taken into consideration in the design are available on written request to ADB SAFEGATE.

ETL certification

The equipment listed as ETL certified means that the product complies with the essential requirements concerning safety and C22.2 No.180:13 (R2018) regulations. The CSA directives that have been taken into consideration in the design are available on written request to ADB SAFEGATE.

All Products Guarantee

ADB SAFEGATE will correct by repair or replacement per the applicable guarantee below, at its option, equipment or parts which fail because of mechanical, electrical or physical defects, provided that the goods have been properly handled and stored prior to installation, properly installed and properly operated after installation, and provided further that Buyer gives ADB SAFEGATE written notice of such defects after delivery of the goods to Buyer. Refer to the Safety section for more information on Material Handling Precautions and Storage precautions that must be followed.

ADB SAFEGATE reserves the right to examine goods upon which a claim is made. Said goods must be presented in the same condition as when the defect therein was discovered. ADB SAFEGATE further reserves the right to require the return of such goods to establish any claim.

ADB SAFEGATE's obligation under this guarantee is limited to making repair or replacement within a reasonable time after receipt of such written notice and does not include any other costs such as the cost of removal of defective part, installation of repaired product, labor or consequential damages of any kind, the exclusive remedy being to require such new parts to be furnished.

ADB SAFEGATE's liability under no circumstances will exceed the contract price of goods claimed to be defective. Any returns under this guarantee are to be on a transportation charges prepaid basis. For products not manufactured by, but sold by ADB SAFEGATE, warranty is limited to that extended by the original manufacturer. This is ADB SAFEGATE's sole guarantee and warranty with respect to the goods; there are no express warranties or warranties of fitness for any particular purpose or any implied warranties of fitness for any particular purpose or any implied warranties other than those made expressly herein. All such warranties being expressly disclaimed.

Standard Products Guarantee

Products manufactured by ADB SAFEGATE are guaranteed against mechanical, electrical, and physical defects (excluding lamps) which may occur during proper and normal use for a period of two years from the date of ex-works delivery, and are guaranteed to be merchantable and fit for the ordinary purposes for which such products are made.



Note

See your applicable sales agreement for a complete warranty description.

Replaced or repaired equipment under warranty falls into the warranty of the original delivery. No new warranty period is started for these replaced or repaired products.

FAA Certified products manufactured by ADB SAFEGATE

ADB SAFEGATE L858 Airfield Guidance Signs are warranted against mechanical and physical defects in design or manufacture for a period of 2 years from date of installation, per FAA AC 150/5345-44 (applicable edition).

ADB SAFEGATE LED products (with the exception of obstruction lighting) are warranted against electrical defects in design or manufacture of the LED or LED specific circuitry for a period of 4 years from date of installation, per FAA EB67 (applicable edition). These FAA certified constant current (series) powered LED products must be installed, interfaced and powered with and through products certified under the FAA Airfield Lighting Equipment Program (ALECP) to be included in this 4 (four) year warranty. This includes, but is not limited to, interface with products such as Base Cans, Isolation Transformers, Connectors, Wiring, and Constant Current Regulators.



Note

See your sales order contract for a complete warranty description.

Replaced or repaired equipment under warranty falls into the warranty of the original delivery. No new warranty period is started for these replaced or repaired products.

Liability



WARNING

Use of the equipment in ways other than described in the catalog leaflet and the manual may result in personal injury, death, or property and equipment damage. Use this equipment only as described in the manual.

ADB SAFEGATE cannot be held responsible for injuries or damages resulting from non-standard, unintended uses of its equipment. The equipment is designed and intended only for the purpose described in the manual. Uses not described in the manual are considered unintended uses and may result in serious personal injury, death or property damage.

Unintended uses, includes the following actions:

- Making changes to equipment that have not been recommended or described in this manual or using parts that are not genuine ADB SAFEGATE replacement parts or accessories.
- Failing to make sure that auxiliary equipment complies with approval agency requirements, local codes, and all applicable safety standards if not in contradiction with the general rules.
- Using materials or auxiliary equipment that are inappropriate or incompatible with your ADB SAFEGATE equipment.
- Allowing unskilled personnel to perform any task on or with the equipment.

Copyright Statement

This manual or parts thereof may not be reproduced, stored in a retrieval system, or transmitted, in any form or by any means, electronic, mechanical, photocopying, recording, nor otherwise, without the author's prior written consent.

This manual could contain technical inaccuracies or typographical errors. The author reserves the right to revise this manual from time to time in the contents thereof without obligation of the author to notify any person of such revision or change. Details and values given in this manual are average values and have been compiled with care. They are not binding, however, and the author disclaims any liability for damages or detriments suffered as a result of reliance on the information given herein or the use of products, processes or equipment to which this manual refers. No warranty is made that the use of the information or of the products, processes or equipment to which this manual refers will not infringe any third party's patents or rights. The information given does not release the buyer from making their own experiments and tests.

TABLE OF CONTENTS

1.0 Description	1
1.1 Intended Use	1
1.2 Working Principle	2
1.3 Layout of the Equipment Cabinet	4
1.3.1 Outside - small cabinet: 2.5 to 15 kVA	4
1.3.2 Inside - small cabinet: 2.5 to 15 kVA	5
1.3.3 Outside - big cabinet 20 to 30 kVA	6
1.3.4 Inside - big cabinet 20 to 30 kVA	7
1.4 Components	7
1.4.1 Line input	8
1.4.2 IGBT power bridge	12
1.4.3 Capacitor bank	14
1.4.4 Hall sensor, big cabinet	14
1.4.5 Output filter	15
1.4.6 Main transformer, all cabinets	15
1.4.7 Output measure PCB (EPS422), all cabinets	16
1.4.8 Power output	16
1.4.9 CPU PCB (EPS479), all cabinets	16
1.4.10 Remote control PCB (EPS495 or EP00047), all cabinets	17
1.4.11 Power supply PCB (EPS480), all cabinets	18
1.4.12 Lamp Fault Detection (LFD)	18
1.4.13 Earth Fault Detection (EFD)	18
1.4.14 Ventilation	18
1.5 Options	19
1.5.1 Remote control	19
1.5.2 Ethernet PCB (EPS542), all cabinets	19
1.5.3 Series Connector Box (SCB), all cabinets	20
1.5.4 Series CutOut (SCO), all cabinets	20
1.5.5 Rolling castors	20
1.6 HMI	20
1.7 Nameplate	21
2.0 Description of the HMI	23
2.1 Display overview: Main screen	23
2.2 Description of general functions	24
2.3 Main menu	25
2.4 Options menu	25
2.5 Alarms menu	25
2.6 Maintenance menu	26
2.7 Mode menu	26
2.8 How to enter an alphanumeric string	26
2.9 Alarm texts and messages on the HMI	27
3.0 Description of the configuration software tool	31
3.1 Description of screens and menus	31
3.2 CCR status screen	32
3.2.1 CCR Status	33
3.2.2 EFD Errors	33
3.2.3 LFD Errors	33
3.2.4 Regulation Errors	34
3.2.5 CCR Errors	34
3.2.6 Mains Voltage Errors	35
3.2.7 Output	35
3.3 Output/Mains screen	36
3.3.1 Output currents	36
3.3.2 Off if overload	37

3.3.3 Overcurrent	37
3.3.4 Step Parameters	37
3.3.5 Mains	37
3.4 Test screen	38
3.4.1 Brightness	38
3.4.2 Ctrl Hardware Iprim	38
3.4.3 Test JBUS	38
3.5 Configuration screen	39
3.5.1 CCR ID	39
3.5.2 Change Slave Number	39
3.5.3 SN/YearCode	40
3.5.4 Maintenance Password	40
3.6 EFD/LFD screen	40
3.6.1 EFD Enable	41
3.6.2 EFD Levels	41
3.6.3 LFD Inh	41
3.6.4 LFD Levels	41
3.6.5 VA Drop + delay	41
3.7 Diag/Dsp/BUS screen	42
3.7.1 Slave Errors	42
3.7.2 Rem Reset	43
3.7.3 Dsp Parameters	43
3.7.4 Imp Test	43
3.7.5 Hours_Meter	44
3.7.6 Rem_Reset_Circuit_selector	44
3.7.7 Speed	44
3.8 Copy Parameters screen	44
3.9 Log screen	45
3.10 Test JBus screen	45
4.0 Install and operate the configuration software tool	47
4.1 Install the configuration tool software	47
4.2 Start the configuration software tool	47
4.3 Monitor the data of an equipment	50
4.4 Stop the configuration software tool	50
5.0 Commissioning	51
5.1 First start-up	51
5.1.1 Procedure	51
5.1.2 Measure input voltage	51
5.1.3 Measure output current in short-circuit	52
5.1.4 Put SCB in short-circuit	52
5.1.5 Put SCO in short circuit	53
5.1.6 Measure the output current in short circuit	54
5.1.7 Measure resistance and the insulation resistance of series circuit	54
5.1.8 Prepare with SCB	55
5.1.9 Prepare with SCO	55
5.1.10 Measure resistance of series circuit	56
5.1.11 Measure insulation resistance of series circuit	56
5.1.12 Calculate minimum insulation resistance of series circuit	56
5.1.13 Calculate resistance of series circuit	56
5.1.14 Complete the measurement	57
5.1.15 Measure the output current to the series circuit	57
5.2 Calibrate Lamp Fault Detection (LFD)	58
5.3 Remote control configuration: multiwire (option)	59
5.4 Remote control configuration: J-Bus (option)	60
5.5 Remote control configuration: ethernet (option)	60
6.0 Operation	61
6.1 Switch ON the equipment	61
6.2 Switch OFF the equipment	62
6.3 Switch OFF the power supply	62

6.4 Switch between local and remote mode	62
6.5 Select brightness step	63
6.6 Adjust number of used brightness steps	63
6.7 Alarms	63
6.8 Use Series CutOut (SCO)	64
6.8.1 Operation mode	64
6.8.2 Adjust operation mode	65
6.9 Operation mode	66
7.0 Troubleshooting	67
7.1 Preliminary checks	67
7.2 Troubleshooting guide	67
7.2.1 Fault: Equipment does not turn ON	68
7.2.2 Fault: Equipment does not go to the ON state	69
7.2.3 Fault: Equipment turns ON but suddenly de-energizes	70
7.2.4 Fault: equipment does not produce requested output current	70
7.3 Checks and measurements	71
7.3.1 Measure input voltage	71
7.3.2 Measure output current	71
7.3.3 Check fuse breaker and voltage of switch board	71
7.3.4 Calculate minimum insulation resistance of series circuit	71
7.3.5 Calculate resistance of series circuit	71
7.3.6 Measure cable capacitance	71
8.0 Maintenance	73
8.1 Preventive maintenance schedule	73
8.2 Part replacement	73
8.2.1 Required tools	74
8.2.2 CPU PCB (EPS479) replacement	75
8.2.3 Diode bridge and sensing PCB (EPS540 / EPS 541) replacement, small cabinet	76
8.2.4 Diode bridge and sensing PCB (EPS 497) replacement, big cabinet	78
8.2.5 Display and keyboard replacement	79
8.2.6 Fuses on the power supply PCB (EPS480) replacement	79
8.2.7 IGBT PCB (EPS477 / EPS 478) replacement, small cabinet	80
8.2.8 IGBT PCB (EPS496) replacement, big cabinet	81
8.2.9 IGBT replacement, small cabinet	82
8.2.10 IGBT replacement, big cabinet	84
8.2.11 Lightning arrestors replacement, equipment with SCO or SCB	84
8.2.12 Line filter replacement	85
8.2.13 Main contactor replacement	86
8.2.14 Main fuses replacement	87
8.2.15 Manual switch replacement	87
8.2.16 Output filter replacement, small cabinet	89
8.2.17 Output filter replacement, big cabinet	91
8.2.18 Output measure PCB (EPS442) replacement	92
8.2.19 Power supply PCB (EPS480) replacement	93
8.2.20 Precharge contactor replacement	93
8.2.21 Precharge PCB (EPS546) replacement, small cabinet	95
8.2.22 Precharge PCB (EPS456) replacement, big cabinet	95
8.2.23 Remote control PCB (EPS495 or EP00051) replacement	96
8.2.24 Series Connection Box (SCB) replacement (option)	97
8.2.25 Series CutOut (SCO) replacement (option)	98
8.3 Remove panels	101
8.3.1 Remove the display / keyboard panel of the small cabinet	102
8.3.2 Remove the display / keyboard panel of the big cabinet	103
8.3.3 Top panel (small cabinet)	104
8.3.4 Generic panels	105
8.4 Firmware update	105
8.4.1 Install the software to upload the firmware	106
8.4.2 Change the SD Flash file paths	107
8.4.3 Check equipment parameters	107
8.4.4 Update the firmware	108

8.4.5 Start the equipment after a firmware update	108
9.0 PCB drawings and settings	111
9.1 CPU PCB (EPS479)	111
9.1.1 LEDs	111
9.2 Power supply PCB (EPS480)	112
9.2.1 LEDs	112
9.2.2 Fuses	112
9.3 Remote Control PCB	113
9.3.1 EPS495 (1597.00.300)	113
9.3.2 EP00047 and EP00051	115
9.3.3 Multiwire/J-Bus connection scheme	116
9.4 IGBT PCB (EPS477 / EPS 496)	119
9.4.1 LEDs EPS477 for 2s Semix	120
9.4.2 Printed Circuit Board (PCB) EPS496 for 3s Semix	120
9.4.3 LEDs EPS477 for 1s and 2s Semix	120
9.5 Output measure PCB (EPS442)	121
9.5.1 LEDs	121
9.6 Diode bridge and sensing PCB (EPS540 / EPS 541 / EPS 497)	121
9.6.1 LEDs	121
9.7 Test parameters	122
9.7.1 Analog channels	122
9.7.2 Input	122
9.7.3 Output	122
9.7.4 External input	122
9.7.5 External output	123
9.7.6 PIC analog channels	123
10.0 Technical Data	125
10.1 Applicable standards	126
10.2 ElectroMagnetic Compatibility (EMC)	126
10.3 Dimensions and mass	127
10.4 Protection devices	128
10.5 Used brightness steps	128
10.6 Ambient conditions	129
10.7 Parts list	129
10.8 Preventive spare parts	129
10.9 Corrective spare parts	134
A.0 SUPPORT	137
A.1 ADB SAFEGATE Website	138
A.2 Recycling	138
A.2.1 ADB SAFEGATE Recycling	138

List of Figures

Figure 1: Series circuit system overview	1
Figure 2: The 5 kVA cabinet	5
Figure 3: The 20 kVA cabinet	7
Figure 4: Input terminal, all cabinets	8
Figure 5: Line filter, all cabinets	8
Figure 6: Manual switch, all cabinets	8
Figure 7: Main fuses, small cabinet	9
Figure 8: Main fuses, big cabinet	9
Figure 9: Main contactor, small cabinet	9
Figure 10: Main contactor, big cabinet	9
Figure 11: Precharge contactor, small cabinet	10
Figure 12: Precharge contactor, big cabinet	10
Figure 13: Precharge PCB (EPS456), all cabinets	10
Figure 14: Sensing transformer, all cabinets	10
Figure 15: Power supply transformer, all cabinets	11
Figure 16: Diode bridge + sensing PCB (EPS540 / EPS541), small cabinet	12
Figure 17: Sensing PCB (EPS497), big cabinet	12
Figure 18: Diode bridge, big cabinet	13
Figure 19: IGBT, all cabinets	13
Figure 20: IGBT PCB (EPS477 /EPS496 /EPS 478), all cabinets	13
Figure 21: Capacitor bank, small cabinet	14
Figure 22: Capacitor bank, big cabinet	14
Figure 23: Hall sensor, big cabinet	14
Figure 24: Output filter, small cabinet	15
Figure 25: Output filter, big cabinet	15
Figure 26: HMI overview	23
Figure 27: General	31
Figure 28: Printed Circuit Board (PCB)	111
Figure 29: Printed Circuit Board (PCB)	112
Figure 30: Printed Circuit Board (PCB)	113
Figure 31: Printed Circuit Board (PCB)	115
Figure 32: Multiwire and J-Bus connection	119
Figure 33: Printed Circuit Board (PCB) EPS477 for2s Semix	119
Figure 34: Printed Circuit Board (PCB)	121
Figure 35: Printed Circuit Board (PCB)	121
Figure 36: The small cabinet (A) and the big cabinet (B)	127

List of Tables

Table 1: Display description: Main screen	23
Table 2: General function buttons	24
Table 3: Display description: Menu screen	25
Table 4: Buttons	25
Table 5: Buttons	25
Table 6: General function buttons	26
Table 7: General function buttons	26
Table 8: Theoretical insulation resistance for the series circuit	56
Table 9: Equipment does not turn ON	68
Table 10: Equipment does not turn ON	69
Table 11: Equipment turns ON but suddenly de-energizes	70
Table 12: Equipment does not produce the requested output current	70
Table 13: Preventive maintenance schedule	73
Table 14: CPU PCB LED functions	111
Table 15: Power supply PCB LED functions	112
Table 16: Power supply PCB Fuses	112
Table 17: Remote control PCB LED functions	113
Table 18: Remote control PCB jumper settings	113
Table 19: Factory set terminal assignments for remote control connections with multiwire and single J-Bus (Cable Set 4072.30.XXX)	116
Table 20: Factory set terminal assignments for remote control connections with multiwire dual J-Bus (Cable Set 4072.30.182)	117
Table 21: IGBT PCB LED functions	120
Table 22: IGBT PCB LED functions	120
Table 23: Phase bridge PCB LED RUN light functions	121
Table 24: LEDs - Diode bridge and sensing PCB LED functions	121
Table 25: Analog channels	122
Table 26: Test input parameters	122
Table 27: Test output parameters	122
Table 28: PIC analog channels test	123
Table 29: Technical Specifications	125
Table 30: Output specifications	125
Table 31: Dimensions	127
Table 32: Mass	127
Table 33: Protection devices specifications	128
Table 34: Current values produced at each brightness step	128

Table 35: Ambient conditions	129
Table 36: Preventive spare parts - Main fuse	130
Table 37: Preventive spare parts - Main contactor	130
Table 38: Preventive spare parts - Lightning arrestors	130
Table 39: Preventive spare parts - Overvoltage protection	130
Table 40: Preventive spare parts - Capacitors	131
Table 41: Preventive spare parts - Safety switch	131
Table 42: Preventive spare parts - Fan	131
Table 43: Preventive spare parts - IGBT bridge	131
Table 44: Preventive spare parts - CPU PCB	131
Table 45: Preventive spare parts - Output measure PCB	132
Table 46: Preventive spare parts - Power supply PCB	132
Table 47: Preventive spare parts - Remote control PCB	132
Table 48: Preventive spare parts - Diode bridge and sensing PCBT	133
Table 49: Preventive spare parts - IGBT PCB	133
Table 50: Preventive spare parts - Precharge PCB	133
Table 51: Preventive spare parts - Ethernet adapter	133
Table 52: Preventive spare parts - Display and keyboard	134
Table 53: Corrective spare parts - Manual switch	134
Table 54: Corrective spare parts - Main fuse housing	134
Table 55: Corrective spare parts - Line filter	135
Table 56: Corrective spare parts - Output filter	135
Table 57: Corrective spare parts - Capacitors	135
Table 58: Corrective spare parts - Precharge resistors	135
Table 59: Corrective spare parts - Main transformer	136
Table 60: Corrective spare parts - Fan connector cable	136

A.0 Safety

Introduction to Safety

This section contains general safety instructions for installing and using ADB SAFEGATE equipment. Some safety instructions may not apply to the equipment in this manual. Task- and equipment-specific warnings are included in other sections of this manual where appropriate.

A.0 Disclaimer / Standard Warranty

CE certification

The equipment listed as CE certified means that the product complies with the essential requirements concerning safety and hygiene. The European directives that have been taken into consideration in the design are available on written request to ADB SAFEGATE.

ETL certification

The equipment listed as ETL certified means that the product complies with the essential requirements concerning safety and C22.2 No.180:13 (R2018) regulations. The CSA directives that have been taken into consideration in the design are available on written request to ADB SAFEGATE.

All Products Guarantee

ADB SAFEGATE will correct by repair or replacement per the applicable guarantee below, at its option, equipment or parts which fail because of mechanical, electrical or physical defects, provided that the goods have been properly handled and stored prior to installation, properly installed and properly operated after installation, and provided further that Buyer gives ADB SAFEGATE written notice of such defects after delivery of the goods to Buyer. Refer to the Safety section for more information on Material Handling Precautions and Storage precautions that must be followed.

ADB SAFEGATE reserves the right to examine goods upon which a claim is made. Said goods must be presented in the same condition as when the defect therein was discovered. ADB SAFEGATE further reserves the right to require the return of such goods to establish any claim.

ADB SAFEGATE's obligation under this guarantee is limited to making repair or replacement within a reasonable time after receipt of such written notice and does not include any other costs such as the cost of removal of defective part, installation of repaired product, labor or consequential damages of any kind, the exclusive remedy being to require such new parts to be furnished.

ADB SAFEGATE's liability under no circumstances will exceed the contract price of goods claimed to be defective. Any returns under this guarantee are to be on a transportation charges prepaid basis. For products not manufactured by, but sold by ADB SAFEGATE, warranty is limited to that extended by the original manufacturer. This is ADB SAFEGATE's sole guarantee and warranty with respect to the goods; there are no express warranties or warranties of fitness for any particular purpose or any implied warranties of fitness for any particular purpose or any implied warranties other than those made expressly herein. All such warranties being expressly disclaimed.

Standard Products Guarantee

Products manufactured by ADB SAFEGATE are guaranteed against mechanical, electrical, and physical defects (excluding lamps) which may occur during proper and normal use for a period of two years from the date of ex-works delivery, and are guaranteed to be merchantable and fit for the ordinary purposes for which such products are made.



Note

See your applicable sales agreement for a complete warranty description.

Replaced or repaired equipment under warranty falls into the warranty of the original delivery. No new warranty period is started for these replaced or repaired products.

FAA Certified products manufactured by ADB SAFEGATE

ADB SAFEGATE L858 Airfield Guidance Signs are warranted against mechanical and physical defects in design or manufacture for a period of 2 years from date of installation, per FAA AC 150/5345-44 (applicable edition).

ADB SAFEGATE LED products (with the exception of obstruction lighting) are warranted against electrical defects in design or manufacture of the LED or LED specific circuitry for a period of 4 years from date of installation, per FAA EB67 (applicable edition). These FAA certified constant current (series) powered LED products must be installed, interfaced and powered with and through products certified under the FAA Airfield Lighting Equipment Program (ALECP) to be included in this 4 (four) year warranty. This includes, but is not limited to, interface with products such as Base Cans, Isolation Transformers, Connectors, Wiring, and Constant Current Regulators.



Note

See your sales order contract for a complete warranty description.

Replaced or repaired equipment under warranty falls into the warranty of the original delivery. No new warranty period is started for these replaced or repaired products.

Liability



WARNING

Use of the equipment in ways other than described in the catalog leaflet and the manual may result in personal injury, death, or property and equipment damage. Use this equipment only as described in the manual.

ADB SAFEGATE cannot be held responsible for injuries or damages resulting from non-standard, unintended uses of its equipment. The equipment is designed and intended only for the purpose described in the manual. Uses not described in the manual are considered unintended uses and may result in serious personal injury, death or property damage.

Unintended uses, includes the following actions:

- Making changes to equipment that have not been recommended or described in this manual or using parts that are not genuine ADB SAFEGATE replacement parts or accessories.
- Failing to make sure that auxiliary equipment complies with approval agency requirements, local codes, and all applicable safety standards if not in contradiction with the general rules.
- Using materials or auxiliary equipment that are inappropriate or incompatible with your ADB SAFEGATE equipment.
- Allowing unskilled personnel to perform any task on or with the equipment.

Copyright Statement

This manual or parts thereof may not be reproduced, stored in a retrieval system, or transmitted, in any form or by any means, electronic, mechanical, photocopying, recording, nor otherwise, without the author's prior written consent.

This manual could contain technical inaccuracies or typographical errors. The author reserves the right to revise this manual from time to time in the contents thereof without obligation of the author to notify any person of such revision or change. Details and values given in this manual are average values and have been compiled with care. They are not binding, however, and the author disclaims any liability for damages or detriments suffered as a result of reliance on the information given herein or the use of products, processes or equipment to which this manual refers. No warranty is made that the use of the information or of the products, processes or equipment to which this manual refers will not infringe any third party's patents or rights. The information given does not release the buyer from making their own experiments and tests.

A.0 Safety Messages

HAZARD Icons used in the manual

For all HAZARD symbols in use, see the Safety section. All symbols must comply with ISO and ANSI standards.

Carefully read and observe all safety instructions in this manual, which alert you to safety hazards and conditions that may result in personal injury, death or property and equipment damage and are accompanied by the symbol shown below.



WARNING
Failure to observe a warning may result in personal injury, death or equipment damage.



DANGER - Risk of electrical shock or ARC FLASH
Disconnect equipment from line voltage. Failure to observe this warning may result in personal injury, death, or equipment damage. ARC Flash may cause blindness, severe burns or death.



WARNING - Wear personal protective equipment
Failure to observe may result in serious injury.



WARNING - Do not touch
Failure to observe this warning may result in personal injury, death, or equipment damage.



CAUTION
Failure to observe a caution may result in equipment damage.



ELECTROSTATIC SENSITIVE DEVICES
This equipment may contain electrostatic devices.

Qualified Personnel



Important Information

The term **qualified personnel** is defined here as individuals who thoroughly understand the equipment and its safe operation, maintenance and repair. Qualified personnel are physically capable of performing the required tasks, familiar with all relevant safety rules and regulations and have been trained to safely install, operate, maintain and repair the equipment. It is the responsibility of the company operating this equipment to ensure that its personnel meet these requirements.

Always use required personal protective equipment (PPE) and follow safe electrical work practice.

A.0 Introduction to Safety



CAUTION

Unsafe Equipment Use

This equipment may contain electrostatic devices, hazardous voltages and sharp edges on components

- Read installation instructions in their entirety before starting installation.
- Become familiar with the general safety instructions in this section of the manual before installing, operating, maintaining or repairing this equipment.
- Read and carefully follow the instructions throughout this manual for performing specific tasks and working with specific equipment.
- Make this manual available to personnel installing, operating, maintaining or repairing this equipment.
- Follow all applicable safety procedures required by your company, industry standards and government or other regulatory agencies.
- Install all electrical connections to local code.
- Use only electrical wire of sufficient gauge and insulation to handle the rated current demand. All wiring must meet local codes.
- Route electrical wiring along a protected path. Make sure they will not be damaged by moving equipment.
- Protect components from damage, wear, and harsh environment conditions.
- Allow ample room for maintenance, panel accessibility, and cover removal.
- Protect equipment with safety devices as specified by applicable safety regulations
- If safety devices must be removed for installation, install them immediately after the work is completed and check them for proper functioning prior to returning power to the circuit.

Failure to follow this instruction can result in serious injury or equipment damage

Additional Reference Materials



Important Information

- IEC - International Standards and Conformity Assessment for all electrical, electronic and related technologies.
- IEC 60364 - Electrical Installations in Buildings.
- CSA - C22.2 No.180:13 (R2018) Series isolating transformers for airport lighting
- FAA Advisory: AC 150/5340-26 (current edition), Maintenance of Airport Visual Aid Facilities.
- Maintenance personnel must refer to the maintenance procedure described in the ICAO Airport Services Manual, Part 9.
- ANSI/NFPA 79, Electrical Standards for Metalworking Machine Tools.
- National and local electrical codes and standards.

A.0 Intended Use



CAUTION

Use this equipment as intended by the manufacturer

This equipment is designed to perform a specific function, do not use this equipment for other purposes

- Using this equipment in ways other than described in this manual may result in personal injury, death or property and equipment damage. Use this equipment only as described in this manual.

Failure to follow this instruction can result in serious injury or equipment damage

A.0 Material Handling Precautions: Fasteners



DANGER

Foreign Object Damage - FOD

This equipment may contain fasteners that may come loose - torque properly.

- Only use fasteners of the same type as the one originally supplied with the equipment.
- Use of incorrect combination of gaskets, bolts and nuts can create severe damages to the product installation and create safety risk .
- You need to know what base the light fixture will be installed in, in order to chose the correct gasket, bolts and nuts.
- Bolt type, length, and torque value are determined by type of base, height of spacers used, and clamp force required in FAA Engineering Brief No 83 (latest revision).
- Due to the risk of bolts vibrating loose, do not use any type of washer with the fixing bolts (such as split lock washers) other than an anti-vibration washer. Anti-vibration washers as defined in FAA EB 83 (latest edition) must be used. For installations other than FAA, use the base can manufacturer's recommendations.
- Always tighten the fasteners to the recommended torque. Use a calibrated torque wrench and apply the recommended adhesive type.
- Obey the instructions of the adhesives necessary for the fasteners.

Failure to follow these warnings may cause the fasteners to loosen, damage the equipment, potentially to loosen the equipment. This can lead to a highly dangerous situation of FOD, with potential lethal consequences.



Note

To minimize the risk of errors, the ADB SAFEGATE Sales Representative will have information on which gasket goes with which base. This information is also provided in the product Data sheets, the User Manuals and the Spare Part Lists.



CAUTION

Use of incorrect combination of gaskets, bolts and nuts can create severe damages to the product installation and create multiple safety risks.

To obtain a safe and watertight installation the O-ring and retaining bolt stated in the document must be used.

You need to know what base the light fixture will be installed in, in order to choose the correct gasket, bolts and nuts.

Failure to follow these cautions can result in equipment damage or aircraft FOD.

A.0 Operation Safety



CAUTION

Improper Operation

Do Not Operate this equipment other than as specified by the manufacturer

- Only qualified personnel, physically capable of operating the equipment and with no impairments in their judgment or reaction times, should operate this equipment.
- Read all system component manuals before operating this equipment. A thorough understanding of system components and their operation will help you operate the system safely and efficiently.
- Before starting this equipment, check all safety interlocks, fire-detection systems, and protective devices such as panels and covers. Make sure all devices are fully functional. Do not operate the system if these devices are not working properly. Do not deactivate or bypass automatic safety interlocks or locked-out electrical disconnects or pneumatic valves.
- Protect equipment with safety devices as specified by applicable safety regulations.
- If safety devices must be removed for installation, install them immediately after the work is completed and check them for proper functioning.
- Route electrical wiring along a protected path. Make sure they will not be damaged by moving equipment.
- Never operate equipment with a known malfunction.
- Do not attempt to operate or service electrical equipment if standing water is present.
- Use this equipment only in the environments for which it is rated. Do not operate this equipment in humid, flammable, or explosive environments unless it has been rated for safe operation in these environments.
- Never touch exposed electrical connections on equipment while the power is ON.

Failure to follow these instructions can result in equipment damage

A.0 Maintenance Safety



DANGER

Electric Shock Hazard

This equipment may contain electrostatic devices

- Do not operate a system that contains malfunctioning components. If a component malfunctions, turn the system OFF immediately.
- Disconnect and lock out electrical power.
- Allow only qualified personnel to make repairs. Repair or replace the malfunctioning component according to instructions provided in its manual.

Failure to follow these instructions can result in death or equipment damage

A.0 Material Handling Precautions: Fasteners



DANGER

Foreign Object Damage - FOD

This equipment may contain fasteners that may come loose - torque properly.

- Only use fasteners of the same type as the one originally supplied with the equipment.
- Use of incorrect combination of gaskets, bolts and nuts can create severe damages to the product installation and create safety risk .
- You need to know what base the light fixture will be installed in, in order to chose the correct gasket, bolts and nuts.
- Bolt type, length, and torque value are determined by type of base, height of spacers used, and clamp force required in FAA Engineering Brief No 83 (latest revision).
- Due to the risk of bolts vibrating loose, do not use any type of washer with the fixing bolts (such as split lock washers) other than an anti-vibration washer. Anti-vibration washers as defined in FAA EB 83 (latest edition) must be used. For installations other than FAA, use the base can manufacturer's recommendations.
- Always tighten the fasteners to the recommended torque. Use a calibrated torque wrench and apply the recommended adhesive type.
- Obey the instructions of the adhesives necessary for the fasteners.

Failure to follow these warnings may cause the fasteners to loosen, damage the equipment, potentially to loosen the equipment. This can lead to a highly dangerous situation of FOD, with potential lethal consequences.



Note

To minimize the risk of errors, the ADB SAFEGATE Sales Representative will have information on which gasket goes with which base. This information is also provided in the product Data sheets, the User Manuals and the Spare Part Lists.



CAUTION

Use of incorrect combination of gaskets, bolts and nuts can create severe damages to the product installation and create multiple safety risks.

To obtain a safe and watertight installation the O-ring and retaining bolt stated in the document must be used.

You need to know what base the light fixture will be installed in, in order to choose the correct gasket, bolts and nuts.

Failure to follow these cautions can result in equipment damage or aircraft FOD.

A.0 Material Handling Precautions, ESD



CAUTION

Electrostatic Sensitive Devices

This equipment may contain electrostatic devices

- Protect from electrostatic discharge.
- Electronic modules and components should be touched only when this is unavoidable e.g. soldering, replacement.
- Before touching any component of the cabinet you shall bring your body to the same potential as the cabinet by touching a conductive earthed part of the cabinet.
- Electronic modules or components must not be brought in contact with highly insulating materials such as plastic sheets, synthetic fiber clothing. They must be laid down on conductive surfaces.
- The tip of the soldering iron must be grounded.
- Electronic modules and components must be stored and transported in conductive packing.

Failure to follow this instruction can result in equipment damage

1.0 Description

Figure 1: Series circuit system overview

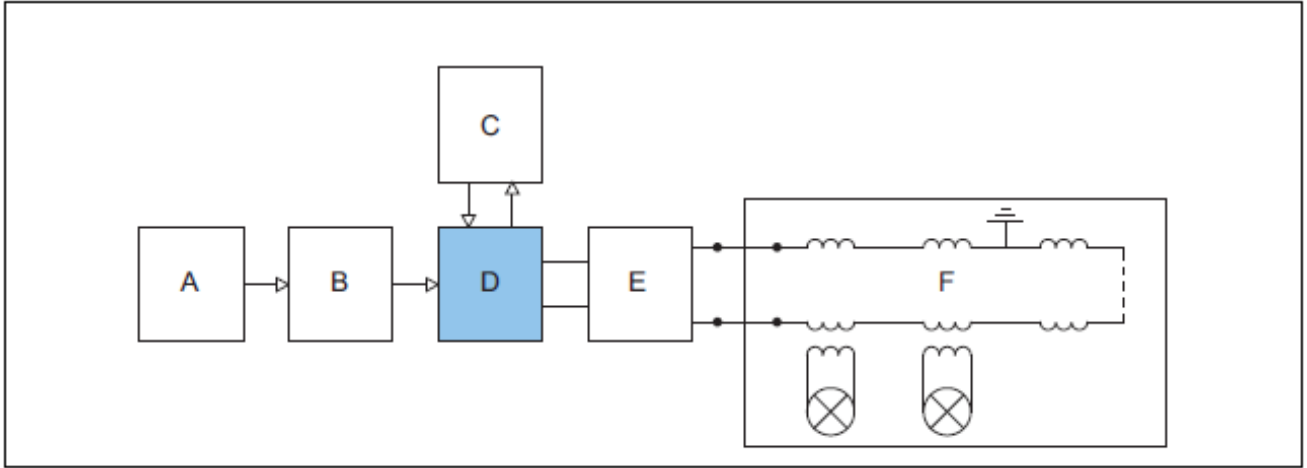

- | | |
|-------------------------|--|
| A Input power supply | D Equipment |
| B Manual switch | E Output disconnection device (optional) |
| C Remote control system | F Series circuit |

The equipment is a microprocessor-controlled Constant Current Regulator with an optional output disconnection device (circuit selector).

1.1 Intended Use

The equipment is designed to convert an AC sine wave input voltage into an adjusted output current selected in brightness steps to supply a series AGL circuit.

Any other or additional use will not be considered to be in conformity with the purpose.

Do not operate the equipment outside the limits of the specifications or outside the specified ambient conditions.

1.2 Working Principle

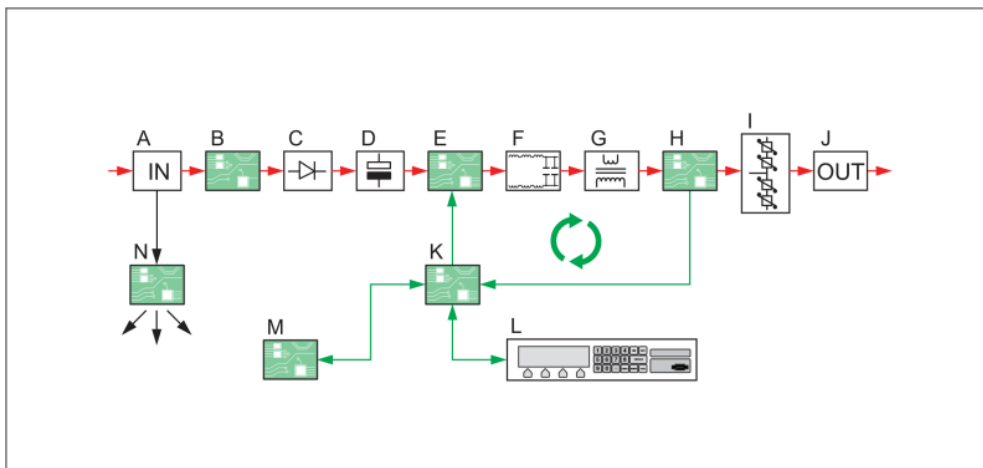
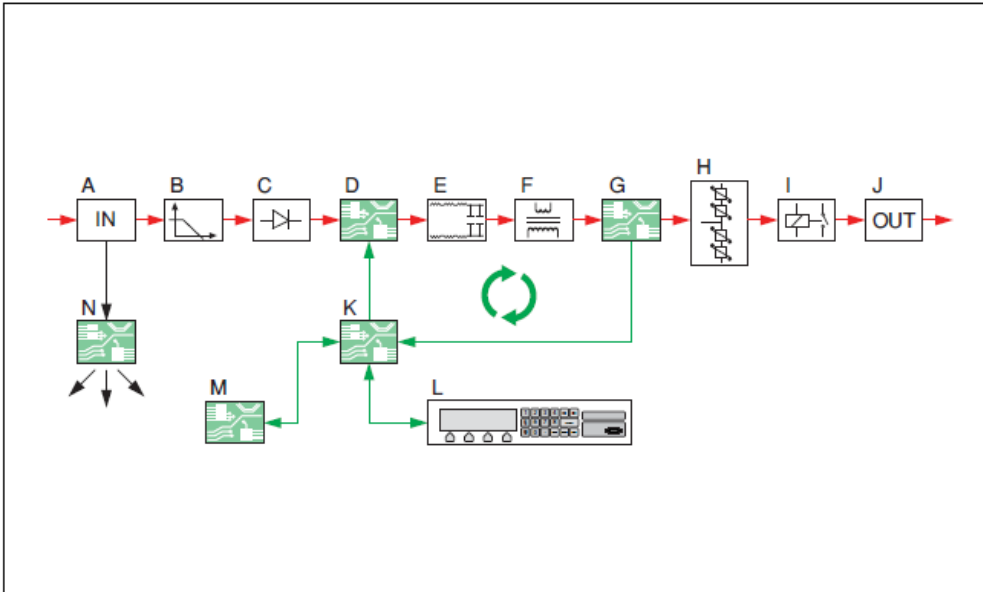

A	Line input. See Line input
B	Precharge PCB. See Line input
C	Diode bridge and sensing PCB. See IGBT power bridge
D	Capacitor bank. See Capacitor bank
E	IGBT module and IGBT PCB. See IGBT power bridge
F	Output filter. See Output filter
G	Main transformer. See Main transformer, all cabinets
H	Output measure PCB. See Output measure PCB (EPS422), all cabinets
I	Lightning arrestors. See Power output
J	Series output connection. See Power output
K	CPU PCB. See CPU PCB (EPS479), all cabinets

L	HMI. See HMI
M	Remote control PCB. See Remote control PCB (EPS495 or EP00047) , all cabinets
N	Power supply PCB. See Power supply PCB (EPS480) , all cabinets

Legend

- Red lines: current
- Green lines: signal wires connections
- Black lines: low voltage connections

Current regulation

The equipment converts the single phase input voltage line into a rectified current and voltage. The equipment then converts this DC current and voltage into a pure sine wave with a defined power rating.

Main feedback loop

The output measure PCB sends the measured output to the CPU PCB. Depending on the output, the CPU PCB automatically generates a signal to adjust the regulation.

1.3 Layout of the Equipment Cabinet

1.3.1 Outside - small cabinet: 2.5 to 15 kVA

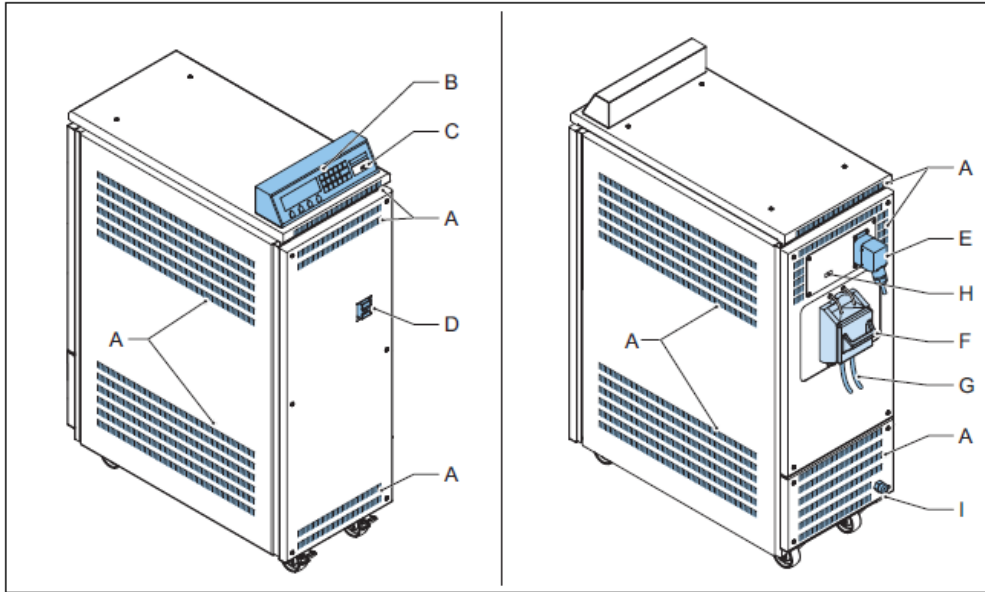

A	Ventilation grids
B	HMI
C	Serial communication port
D	Manual switch
E	Remote control connector
F	Series output connection. The illustration shows the SCO
G	Output to Series Circuit
H	Ethernet connector
I	Power supply cable entry

1.3.2 Inside - small cabinet: 2.5 to 15 kVA

Figure 2: The 5 kVA cabinet

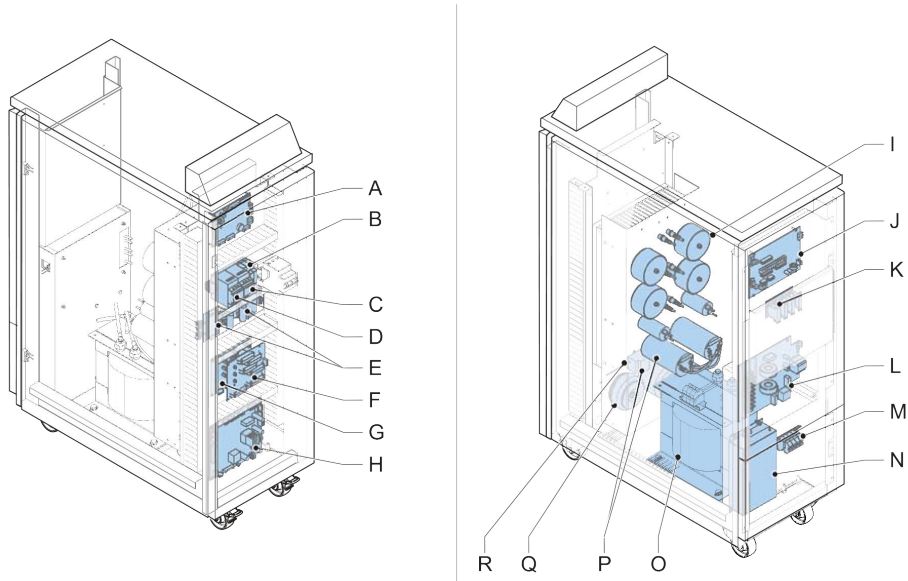

A	CPU PCB (EPS479)
B	Main fuses
C	Main contactor
D	Precharge contactor
E	IGBT module and IGBT PCB (EPS477)
F	Precharge PCB
G	Diode bridge and sensing PCB (EPS 540 / EPS541)
H	Power supply PCB (EPS480)
I	Output filter
J	Remote control PCB (EPS495)
K	Lightning arrestors
L	Output measure PCB (EPS422)
M	Input terminals
N	Line filter
O	Main transformer
P	Capacitor bank
Q	Power supply transformer
R	Sensing transformer

1.3.3 Outside - big cabinet 20 to 30 kVA

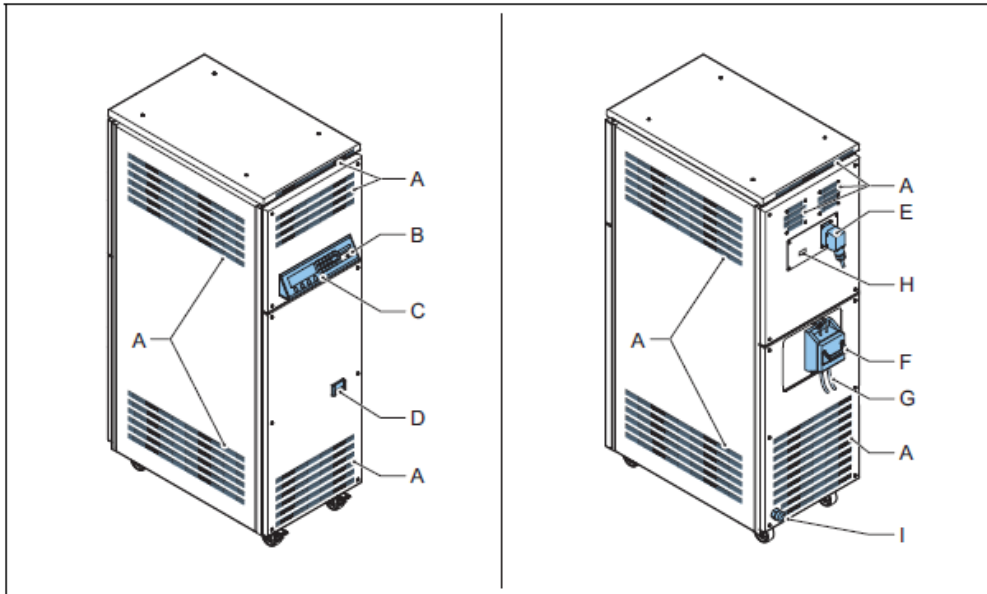

A	Ventilation grids
B	HMI
C	Serial communication port
D	Manual switch
E	Remote control connector
F	Series output connection. The illustration shows the SCO
G	Output to Series Circuit
H	Ethernet connector
I	Power supply cable entry

1.3.4 Inside - big cabinet 20 to 30 kVA

Figure 3: The 20 kVA cabinet

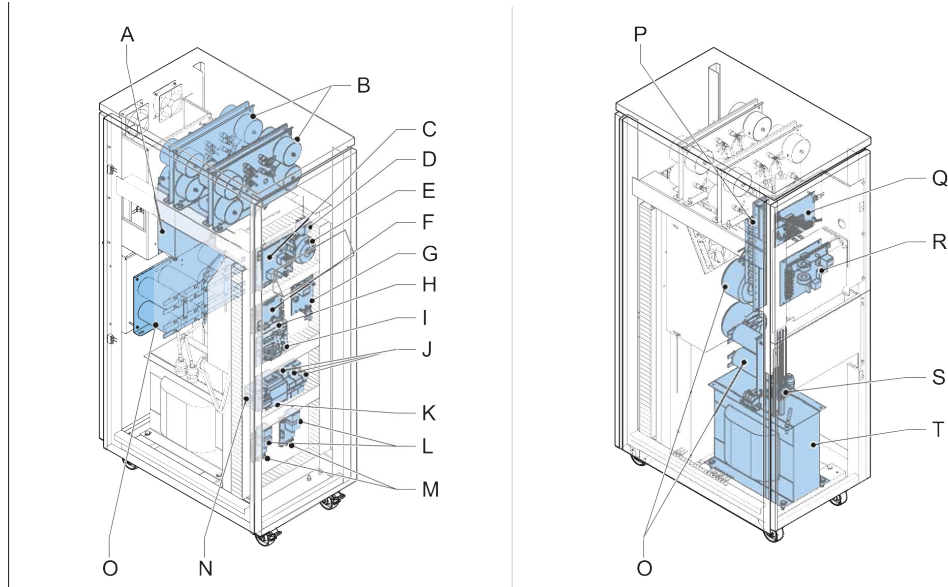

A	Line filter
B	Output filter
C	Power supply PCB (EPS480)
D	Sensing transformer
E	Power supply transformer
F	CPU PCB (EPS479)
G	Sensing PCB (EPS497)
H	Diode bridge
I	Precharge PCB (PCB456)
J	Main fuses
K	Main contactor
L	IGBT module
M	IGBT PCB (EPS496/ EPS478)
N	Precharge contactor
O	Capacitator bank
P	Lightning arrestors
Q	Remote control PCB (EPS495)
R	Output measure PCB (EPS422)
S	Input terminals
T	Main transformer

1.4 Components

For the exact location and connectors see [Layout of the Equipment Cabinet](#) and the electrical scheme. You can find the electrical scheme attached on the outside of the equipment.

1.4.1 Line input

Figure 4: Input terminal, all cabinets

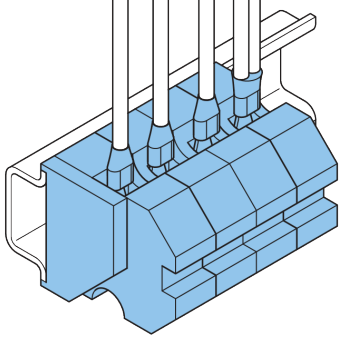

The input terminal connects the power input cables to the equipment.

Figure 5: Line filter, all cabinets

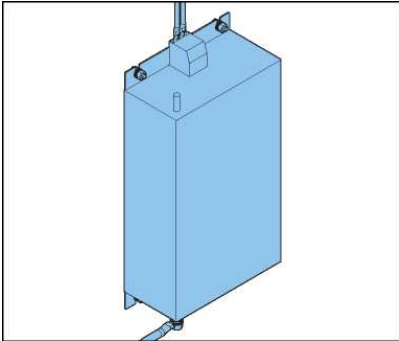

The line filter blocks the noise the equipment generates to the line input and filters out voltage pulses from the input voltage.

Figure 6: Manual switch, all cabinets

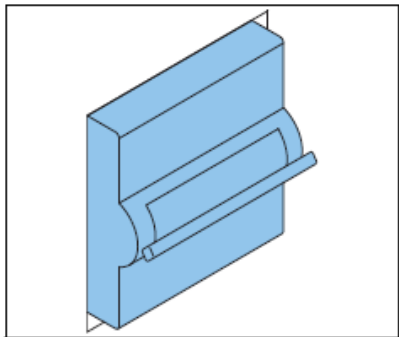

The manual switch is a magneto-thermal switch that connects the mains power supply to the equipment. You can manually set the switch to the **ON** or **OFF** position.

Figure 7: Main fuses, small cabinet

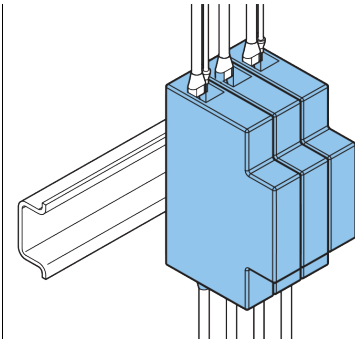

The main fuses disconnect the equipment from the mains power supply if the input current is above a given value.

Figure 8: Main fuses, big cabinet

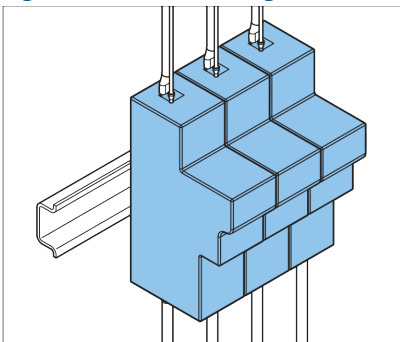

The main fuses disconnect the equipment from the mains power supply if the input current is above a given value.

Figure 9: Main contactor, small cabinet

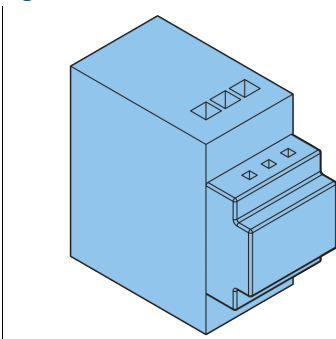

The main contactor allows the power supply PCB to automatically interrupt the power.

Figure 10: Main contactor, big cabinet

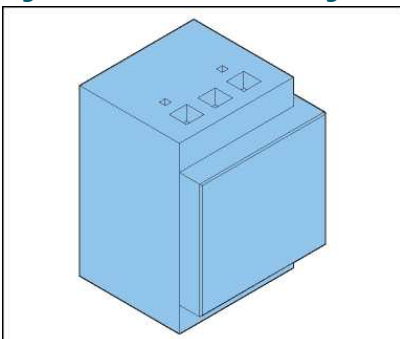

The main contactor allows the power supply PCB to automatically interrupt the power.

Figure 11: Precharge contactor, small cabinet

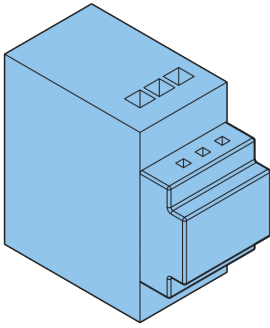

The precharge contactor allows a smooth charge of the capacitors on the capacitor bank.

Figure 12: Precharge contactor, big cabinet

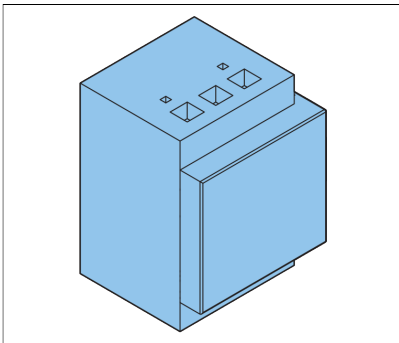

The precharge contactor allows a smooth charge of the capacitors on the capacitor bank.

Figure 13: Precharge PCB (EPS456), all cabinets

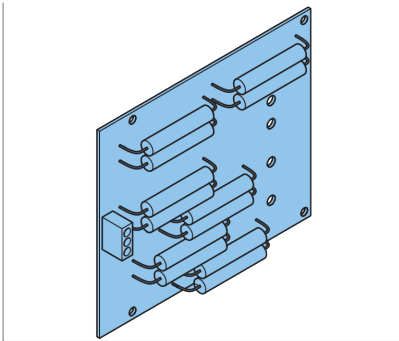

The resistors on the precharge PCB limit the current for the precharge of the capacitor bank.

Figure 14: Sensing transformer, all cabinets

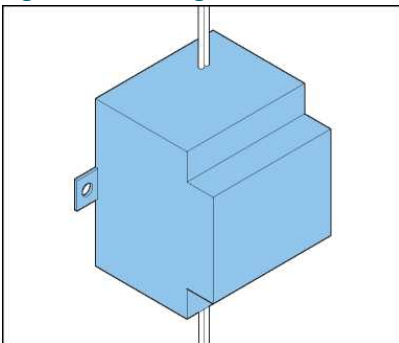

The sensing transformer measures the difference in the input voltage level between phases L1 and L2.

Figure 15: Power supply transformer, all cabinets

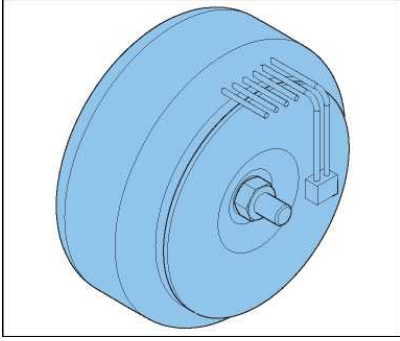

The power supply transformer:

- Measures the input voltage level between phases L2 and L3.
- Provides the correct current and voltage to power all the electronic components such as PCBs and to power the fans (for 15 to 30kVA equipment).

1.4.2 IGBT power bridge

Figure 16: Diode bridge + sensing PCB (EPS540 / EPS541), small cabinet

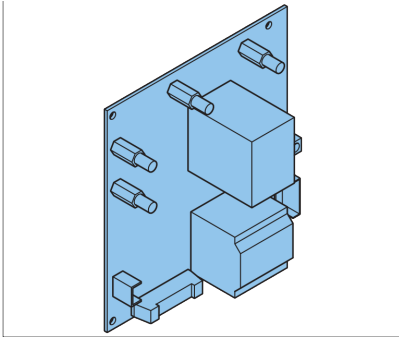

The diode bridge converts the AC line input to a rectified current and voltage.



Note

The sensing PCB measures the AC input line.



Note

In the small cabinet, the sensing PCB and the diode bridge are combined into one part.

Figure 17: Sensing PCB (EPS497), big cabinet

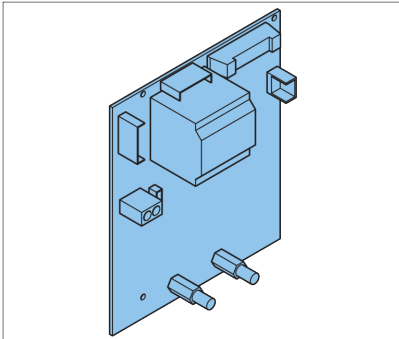

Note

The sensing PCB measures the AC input line and controls the diode bridge.

i Note In the big cabinet, the sensing PCB and the diode bridge are separate parts.

Figure 18: Diode bridge, big cabinet

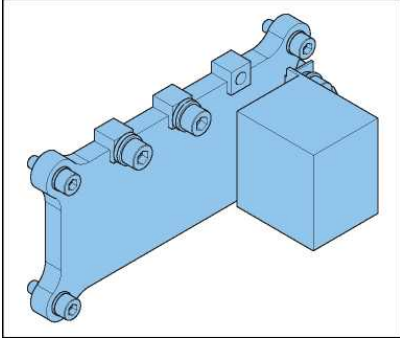

The diode bridge converts the AC line input to a rectified current and voltage.

i Note In the big cabinet, the sensing PCB and the diode bridge are separate parts.

Figure 19: IGBT, all cabinets

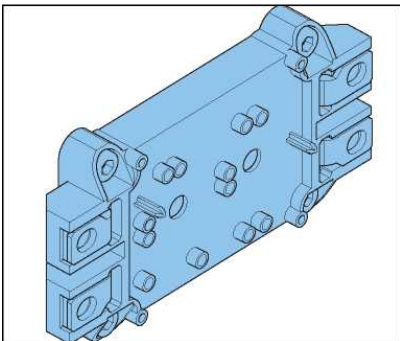

An IGBT controls a high power via a low power electronic signal.

The IGBT can switch at high frequency.

Two IGBTs are installed together in one housing.

The system uses four IGBTs connected as an H-bridge to make an AC-signal.

Figure 20: IGBT PCB (EPS477 /EPS496 /EPS 478), all cabinets

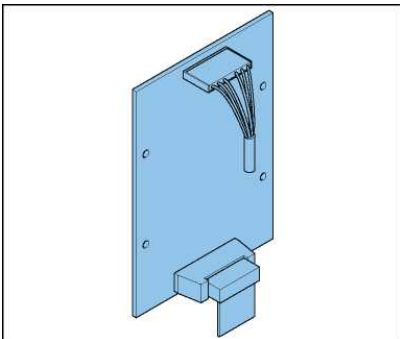

The IGBT PCB measures the output signal from the IGBT H-bridge.

1.4.3 Capacitor bank

The capacitor bank smoothens the DC current and voltage to make a constant DC current and voltage.

Figure 21: Capacitor bank, small cabinet

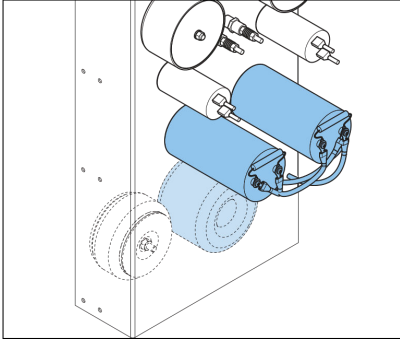
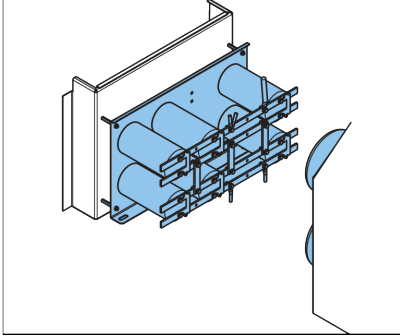
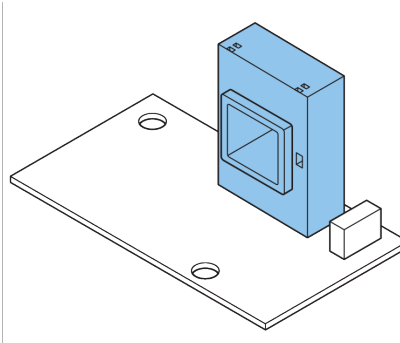

Figure 22: Capacitor bank, big cabinet



1.4.4 Hall sensor, big cabinet

Figure 23: Hall sensor, big cabinet



The Hall sensor measures the current between the IGBT and the output filter.

1.4.5 Output filter

Figure 24: Output filter, small cabinet

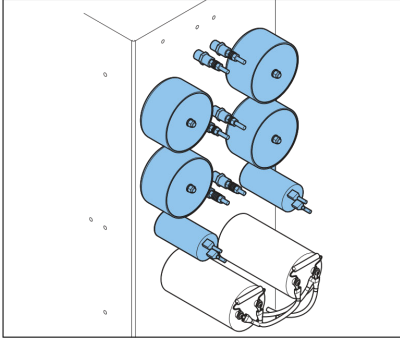

The output filter is a Pulse Width Modulation (PWM) filter that builds the pure sine wave signal that comes from the H-bridge.

Figure 25: Output filter, big cabinet

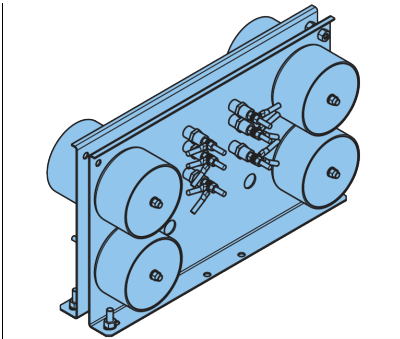

The output filter is a Pulse Width Modulation (PWM) filter that builds the pure sine wave signal that comes from the H-bridge.

1.4.6 Main transformer, all cabinets

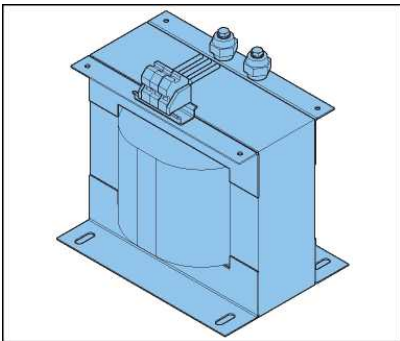

The main transformer converts the pure sine wave to the correct output voltage and current.

1.4.7 Output measure PCB (EPS422), all cabinets

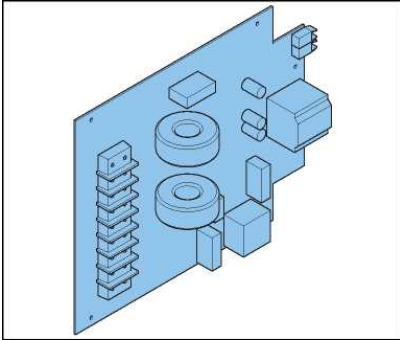

The output measure PCB measures the output voltage and current and sends these measurements to the CPU PCB.

The EFD (See [Earth Fault Detection \(EFD\)](#)) and LFD (See [Lamp Fault Detection \(LFD\)](#)) logic is also located on the output measure PCB.

1.4.8 Power output

Lightning arrestors, all cabinets

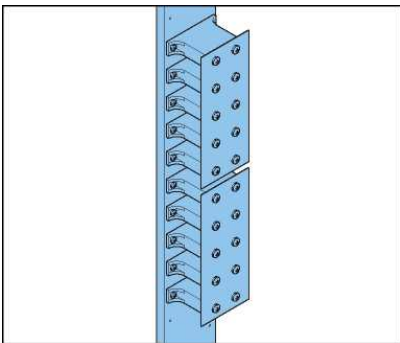

- The lightning arrestors are installed on the power output. The lightning arrestors are varistors.
- A varistor is a surge protection device that is connected directly across the AC output.

Connection to the series circuit

- There are mutual exclusive options possible. See [Options](#).

1.4.9 CPU PCB (EPS479), all cabinets

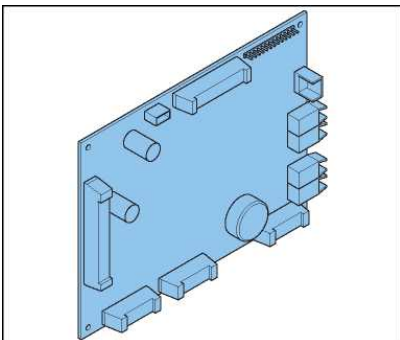

The CPU PCB:

- Receives the measurement data of the output current and voltage from the output measure PCB via an optical fibre and compares these values with the required values. A software algorithm processes this data to adjust the signals from the output filters.
- Receives and processes input signals from the HMI and the remote control PCB.

1.4.10 Remote control PCB (EPS495 or EP00047), all cabinets

i Note

Until 2022, the VIS was delivered with the EPS495 board as the remote control PCB. Since 2022, the VIS has been delivered with the EP00047, and the EP00051 as an add-on board when Multiwire is required. The functionalities of these boards are equivalent in most cases, with the exception of the most demanding recent ALCMS systems with a redundant bus. For VIS units equipped with the EPS495, there are options to transition to the EP00047 (and the EP00051 add-on if needed) when required. Please contact your ADB Safegate representative for more details if needed.

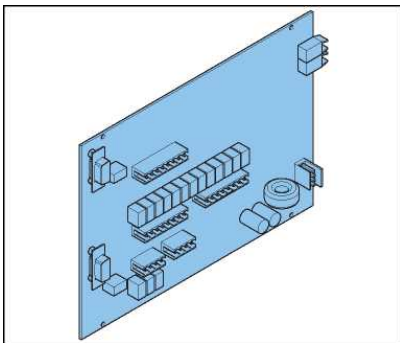

The equipment can be monitored or controlled remotely with J-Bus (2-wire RS485), multiwire or ethernet. This remote control allows the remote control system to:

- Receive information about the equipment.
- Configure the brightness steps.
- Test the equipment.

The remote control PCB connects the equipment to the remote control system. The internal connection between the remote control PCB and the CPU PCB goes through an optical fibre.

i Note

For EPS495, remote control through an ethernet connection requires an additional PCB. See [Ethernet PCB \(EPS542\), all cabinets](#).

i Note

For EP00047, Multiwire support requires an add-on PCB, EP00051.

1.4.11 Power supply PCB (EPS480), all cabinets

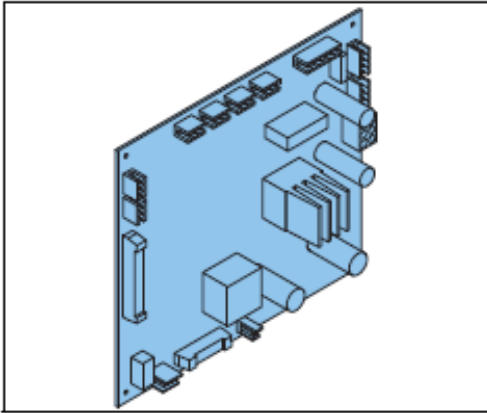

The power supply PCB provides the power supply for:

- All electronic components such as PCBs of the equipment
- The fans (for 15 to 30 kVA equipments)
- The control for the main contactor

The power supply PCB also manages the safety switches on the panels.

1.4.12 Lamp Fault Detection (LFD)

The equipment analyses the output current and the voltage pattern to calculate, on a linear load, the number of open circuited lamps, in compliance with IEC 61822:2009.

The accuracy is ± 1 lamp with a range from 1 to 15 broken lamps.

The HMI shows the actual LFD value.

1.4.13 Earth Fault Detection (EFD)

The EFD measures the insulation resistance between the series circuit and the earth in compliance with IEC 61822:2009.

The EFD module works when the equipment is connected to the mains supply, even if no output current is present.

You can set two alarm levels, Level 1 and Level 2, for the measured values. Both alarm levels can be set to any value between 5 kOhm and 500 MOhm. However, Level 1 must always be higher than Level 2.

Working principle: A high-voltage resistor applies a stable, current-limited voltage of 450 VDC between the series circuit and the earth or cable screen.

The HMI shows the actual EFD value.



Note

EFD measurement is done through a DC voltage with a positive voltage applied on to the series circuit and the 0 (zero) to the earth.

1.4.14 Ventilation

The equipment has air ventilation grids for air inlet and air outlet. The air circulation cools the equipment. For 15 to 30 kVA equipments, additional fans cool the equipment.

1.5 Options

1.5.1 Remote control

i Note

Until 2022, the VIS was delivered with the EPS495 board as the remote control PCB. Since 2022, the VIS has been delivered with the EP00047, and the EP00051 as an add-on board when Multiwire is required. The functionalities of these boards are equivalent in most cases, with the exception of the most demanding recent ALCMS systems with a redundant bus. For VIS units equipped with the EPS495, there are options to transition to the EP00047 (and the EP00051 add-on if needed) when required. Please contact your ADB Safegate representative for more details if needed.

The following remote control connections are possible:

- Ethernet (Ethernet PCB required for EPS495)
 - Single
 - Double
- J-Bus
 - Single
 - Double
- Multiwire with 8 input signals and 17 output signals, always possible to monitor via single J-Bus. For CRE units equipped with EP00047, the add-on board EP00051 is also required.

1.5.2 Ethernet PCB (EPS542), all cabinets

i Note

This applies to CRE units equipped with EPS495.

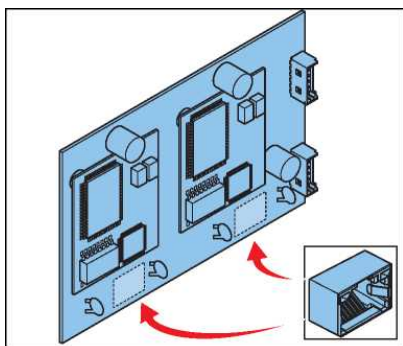

The ethernet PCB converts the ethernet to an RS-485 signal. This PCB is required for EPS495 if you need to remotely operate the equipment through an ethernet connection.

The illustration shows a double ethernet connection.

1.5.3 Series Connector Box (SCB), all cabinets

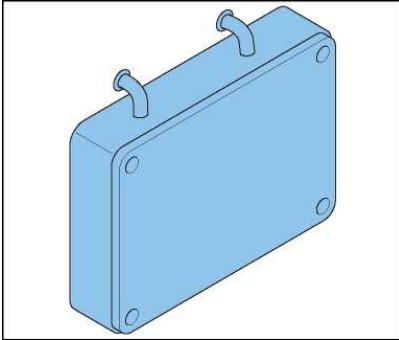

The SCB connects the equipment to the series circuit with two medium voltage cables of the primary circuit. The SCB does not allow the short circuit connection.

1.5.4 Series CutOut (SCO), all cabinets

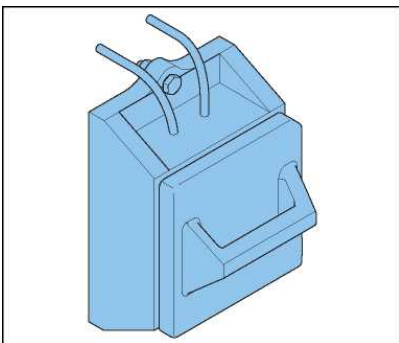

The SCO acts as an output disconnection device between the equipment and the series circuit. The SCO also isolates the series circuit from the equipment during maintenance or testing operations. The cover is locked with a key to prevent unauthorized access.

1.5.5 Rolling castors

The equipment can be supplied with two fixed and two pivoting rolling castors to facilitate the movement of the equipment. The option is not available for stackable equipments or for an equipment with a CS.

1.6 HMI

You can operate the equipment with the HMI.

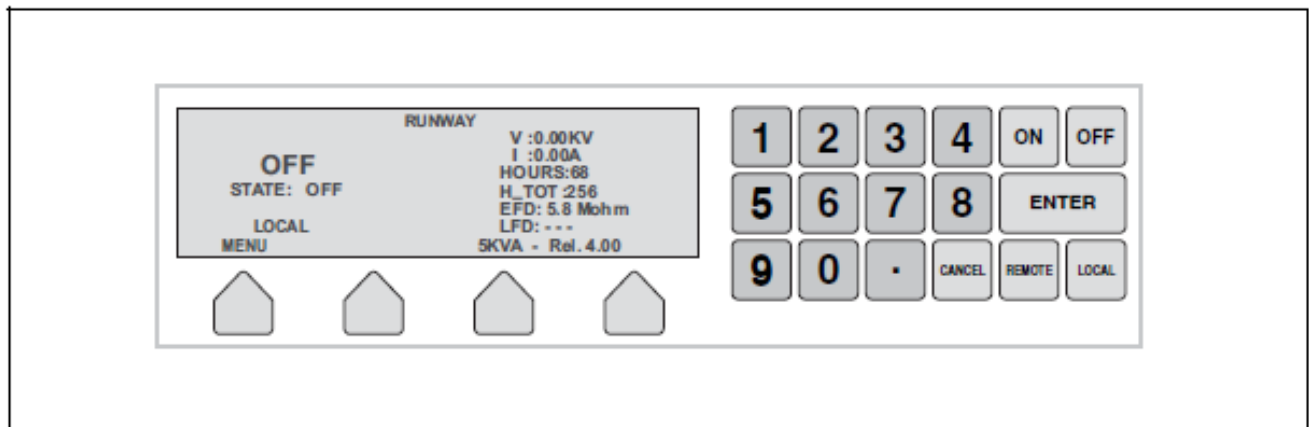

1.7 Nameplate

Each equipment has a standard nameplate:

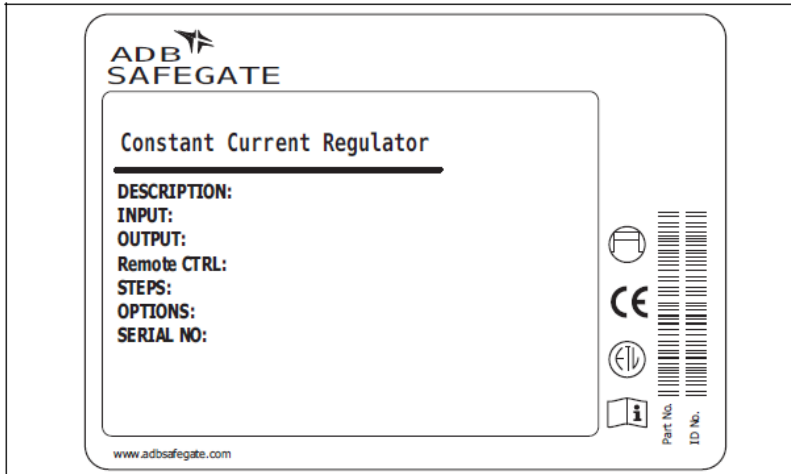

2.0 Description of the HMI

Figure 26: HMI overview

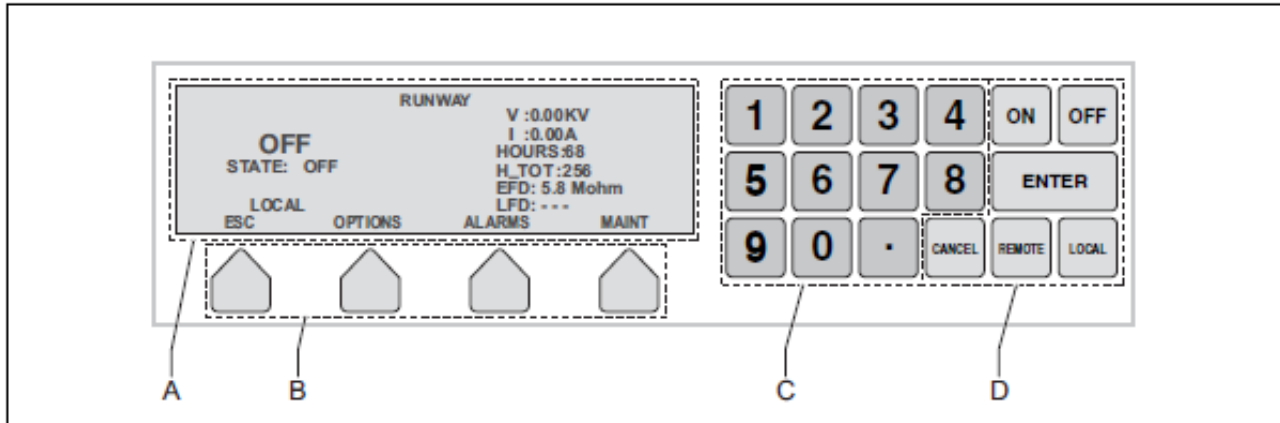

- A. Display
- B. Function buttons
- C. Keypad
- D. **On, Off, Enter, Cancel, Remote** and **Local** buttons

2.1 Display overview: Main screen

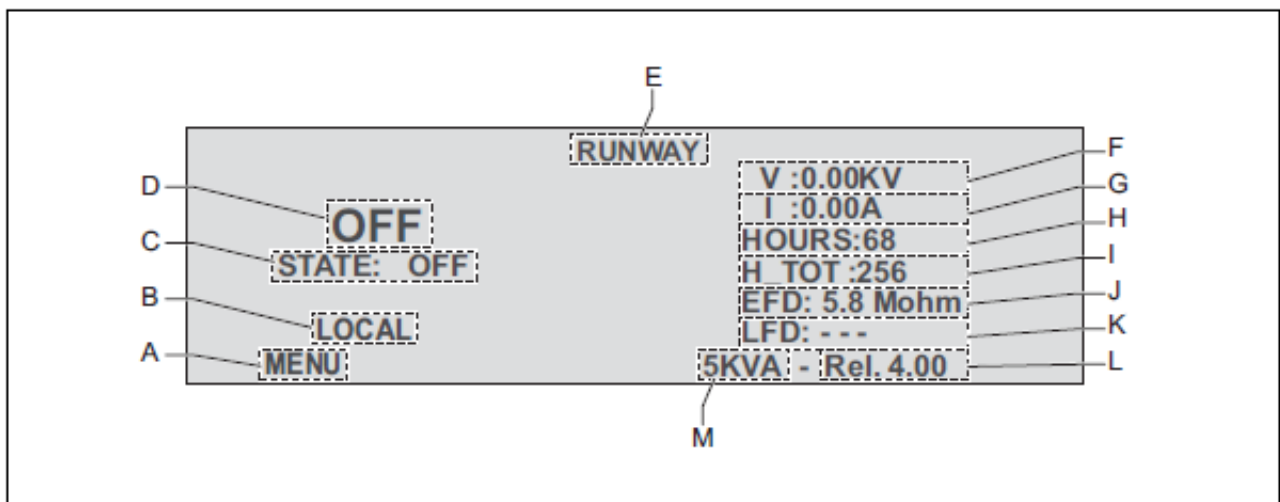

Table 1: Display description: Main screen

Name	Description
A Menu	Push the corresponding function button to go to the Main menu
B Mode indication	Shows the state, LOCAL or REMOTE
C State	The state can be OFF or ON
D Brightness level	OFF, or BRIGHTNESS 0 to 5. Optionally, more levels are possible. If the display shows BRIGHTNESS 0, this means that the equipment has a pre-defined current as output, due to a remote control loss
E Field circuit	Shows the name of the field circuit that the equipment delivers power to
F True RMS output voltage	Shows the true RMS output voltage in kV

Table 1: Display description: Main screen (Continued)

Name	Description
G True RMS output current	Shows the true RMS output current in A
H Highest brightness step counter	Shows the time that the equipment operates at the maximum brightness step in h
I Total brightness counter	Shows the total time that the equipment is set to 'on' in h
J EFD indicator	Shows the measurement of the resistance to earth. The equipment continuously measures the value, also when the equipment is in the OFF state, when the equipment has power
K LFD indicator	In normal mode (linear load): Shows the number of broken lamps if the LFD is calibrated In inductive mode (non-linear load): Shows the text 'inductive'
L Software version	Shows the current software version
M Power rating	Shows the power rating of the equipment

2.2 Description of general functions

The buttons can have different functions. The display description indicates the dedicated functions. This section shows the general functions, which are available in several menus.

Table 2: General function buttons

Button	Description
→	To go to the next submenu
←	To go to the previous submenu
ESC	To go to the higher level menu
-	To decrease the value
+	To increase the value
YES	To confirm the selection
NO	To decline the selection
SAVE	To save an alphanumeric or numeric string
UP, DOWN, LEFT, RIGHT	To move the cursor in the display

2.3 Main menu

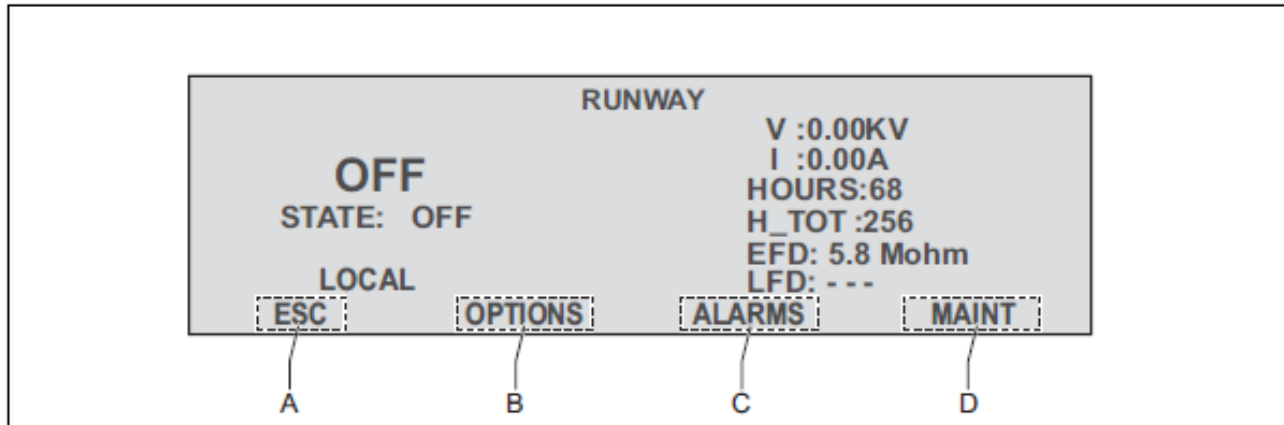

Table 3: Display description: Menu screen

Name	Description
A ESC	To return to the Main menu. See Main menu
B OPTIONS	To go to the Options menu. See Options menu
C ALARMS	To go to the Alarms menu. See Alarms menu
D MAINT	To got to the Maintenance menu. See Maintenance menu

2.4 Options menu

Table 4: Buttons

Button	Description
RS232/485	To activate or deactivate the RS232 or RS485 port
MODE	To select the correct equipment work mode (see Operation mode): <ul style="list-style-type: none"> • NORMAL (for linear loads) • INDUCTIVE (for non-linear loads (e.g. LED loads))
ID	To change the name of the field circuit that the equipment powers. See How to enter an alphanumeric string how to enter an alphanumeric string with the HMI
SLVNUM	To change the address number of the equipment in the RS485 network
LANG	To change the language of the display
CONTR	To change the display contrast
LFD	To calibrate the LFD
HCOUNT	To reset the HOURS indicator

2.5 Alarms menu

Table 5: Buttons

Button	Description
RESET	To reset the alarm: See also Alarms
FORWARD	To show the previous alarm in the list: See also Alarm texts and messages on the HMI .

For an overview of alarm texts and messages, see [Alarm texts and messages on the HMI](#)

2.6 Maintenance menu

A password is required to access the maintenance menu.

Table 6: General function buttons

Button	Description
TEST	Shows the DSP microcontroller operating parameters. These parameters show the state of the software process that controls the equipment. These parameters are only for an advanced user.
MORE	To go to more submenus: <ul style="list-style-type: none">• IGBT TEST A verification test of the IGBT.• INPUT FREQ Do not change this parameter.• REMOTE CONTROL MODE Multiwire or J-Bus• JBUS PROTOCOL MCR2 protocol or MCR3 protocol• CSE/MODE Activate circuit selector. Yes or No.• JBUS mode 485 or Ethernet mode• MULTIWIRE CONFIGURATION To configure the output pins of the multiwire connector. You can change the connector function with the ON and OFF buttons. To save the configuration, push the ENTER button.• V/I CALIBRATION Do not use this parameter.• ETHERNET CONFIGURATION Only for an equipment with the Ethernet Remote Control PCB. To configure the 2 IP addresses.

2.7 Mode menu

Table 7: General function buttons

Button	Description
RAMP TIME	The time that the equipment takes to change from one brightness step to another, in seconds (0 to 125 s).
HALFWAVE WIDTH	To enhance the current peak. You can decrease the half wave width and so reshape the sinusoidal waveform (50 to 100%). The default value is 100% (no enhancement).
MAX PWM WIDTH	To smoothen the maximum current the equipment can supply to prevent a too high current to run on the lamps. You can reduce maximum power threshold on the PWM cycle (1 to 100%). The default value is 100% (no threshold on the current output).
CURRENT LIMIT	Maximum peak current
PID TYPE	Do not change this parameter

2.8 How to enter an alphanumeric string

1. The display shows an alphanumeric matrix (B).
2. Push the LEFT and RIGHT buttons to select the character.
3. Push the ENTER button. The HMI adds the character to the string (A).

4. Push the CANCEL button to delete the last character.

5. Push the SAVE button to confirm the string.

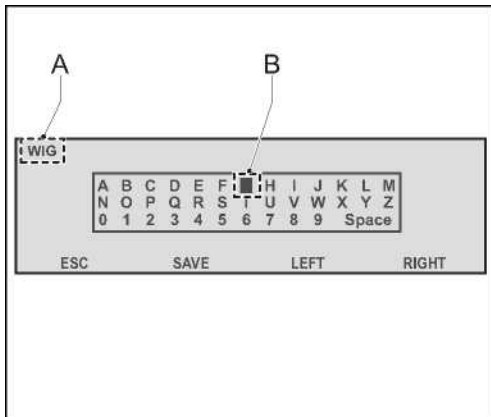

2.9 Alarm texts and messages on the HMI

There are four types of alarms:

- Equipment alarms
 - The equipment automatically switches **OFF**. Restart the equipment only after you have found the cause of the alarm.
 - The red light goes on but the equipment still operates. Find the cause of the alarm.
- Field alarms
 - The equipment automatically switches **OFF**. Restart the equipment only after you have found the cause of the alarm.
 - The red light goes on but the equipment still operates. Find the cause of the alarm.

Alarm text / message	Possible cause	Equipment alarm	Field alarm	Only red light goes on	Equipment switches off automatically
450V EFD MISSING	The 450 V EFD test voltage is missing	x		x	
560VDC BUS OVERCURRENT	The current on the primary power transformer is too high	x			x
ALARM!!!	Several alarms have occurred at the same time	x			x
BAD REGULATION	The current did not reach the selected level within the ramp up time	x		x	
DSP ERROR OR WRONG FIRMWARE	The CPU DSP has failed or the DSP firmware is corrupted	x			x
EFD LEVEL 1 FAULT	The resistance to earth is less than level 1 (20 MOhm default value)		x	x	
EFD LEVEL 2 FAULT	The resistance to earth is less than level 2 (2 MOhm default value)		x	x	

Alarm text / message	Possible cause	Equipment alarm	Field alarm	Only red light goes on	Equipment switches off automatically
GATE H FAULT	There is a problem with the H-bridge (IGBT). On the HMI, a message shows "IGBT KO: xxx x"	x			x
IGBT KO: ...	Both IGBTs are broken	x		x	
IGBT KO: BTM A	The IGBT A is broken	x		x	
IGBT KO: TOP A	The IGBT A is broken	x		x	
IGBT KO: BTM B	The IGBT B is broken	x		x	
IGBT KO: TOP B	The IGBT B is broken	x		x	
IGBT KO: TOP BTM A	The IGBT A is broken	x		x	
IGBT KO: TOP BTM B	The IGBT B is broken	x		x	
INPUT VOLTAGE TOO HIGH	The input voltage is too high	x		x	
INPUT VOLTAGE TOO LOW	The input voltage is too low. This can lead to an over current situation	x			x
LFD LEVEL 1 FAULT	Minimum 3 broken lamps		x	x	
LFD LEVEL level 2 fault	Minimum 5 broken lamps		x	x	
MAIN CONTACTOR FAILED (OFF)	The main contactor is broken	x			x
MAIN CONTACTOR FAILED (ON)	The main contactor is broken	x			x
MAIN DC <95%	The rectified 560 V DC voltage is too low. (Only applies to 3 phase input)	x			x
MAIN REMOTE CTRL SWITCH OFF	The main remote control switch does not go on when the microprocessor gives an 'on' command	x			x
MAIN REMOTE CTRL SWITCH ON	The main remote control switch goes on before the microprocessor gives an 'off' command	x			x
MANY ERRORS HAVE HAPPENED, DURING CONTROL	Different alarms are generated in the same alarm time interval after the equipment startup phase	x			x
MANY ERRORS HAVE HAPPENED, DURING ON	Different alarms are generated in the same alarm time interval during the equipment startup phase	x			x
NO FAN	One or more fans do not operate correctly	x		x	
ONE PHASE MISSING	One phase is missing. The display shows which phase is missing	x			x
OPEN CIRCUIT	The output circuit is interrupted. Link the cable correctly before you restart the equipment		x		x
OVERCURRENT	<ul style="list-style-type: none"> The output current is more than $I_{max} + 5\%$ for minimum 4s The output current is more than $I_{max} + 20\%$ for minimum 0.4 s 		x		x

Alarm text / message	Possible cause	Equipment alarm	Field alarm	Only red light goes on	Equipment switches off automatically
OVERLOAD	The load of the equipment is too high		x	x	
OVERVOLTAGE FROM FIELD	The "IGBT OVP" has stopped the equipment when it could not find a suitable operation mode after several retries		x		x
PHASE ERROR	There is a problem with the mains frequency detection	x		x	
PIC COMMUNICATION ERROR	A faulty communication with the measurement PCB	x			x
PRE-CHARGE CONTACTOR ON	The pre-charge contactor is broken (VIS only)	x			x
PRE-CHARGE CONTACTOR OFF	The pre-charge contactor is broken (VIS only)	x			x
SCO / DOOR OPENED	A front, rear and or field connection panel is open	x			x
TEMPERATURE SENSOR FAULT	There is a fault in the temperature measurement circuit	x		x	
TLC ERROR	There is an error on the remote control PCB	x		x	
TOO HIGH TEMPERATURE	The temperature of the heat sink is too high	x		x	
V IN UNSTABLE	The input voltage is not stable	x		x	
VA DROP LEVEL EXCEEDED	The output power goes below a preset level	x		x	

3.0 Description of the configuration software tool

With the configuration software tool, you can:

- Read the state of the equipment (alarms, output current, input current)
- Read the configuration of the equipment
- Adjust the configuration of the equipment
- Test the equipment
- Send writing and reading commands to the equipment



WARNING

When you activate the configuration tool, you transfer all control of the equipment to the configuration software tool. In this situation, remote or local control of the equipment is not possible.

To update the software version, contact ADB Safegate.

3.1 Description of screens and menus

Figure 27: General

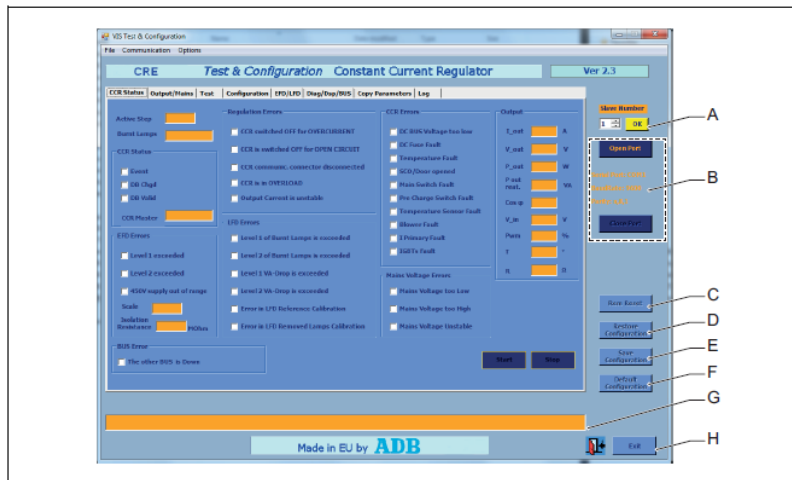

	Description	
A	Slave	To select the slave number of the equipment you want to connect to
B	Connection	To open and close the port to the selected slave number
C	Rem Reset	To reset the alarm. See also Alarms
D	Restore configuration	To restore a saved configuration from the PC to the equipment
E	Save configuration	To make the values sent to the equipment active on eeprom The values you send to the equipment are not active on the eeprom
F	Default configuration	To return to the factory default configuration
G	Message bar	Shows communication messages and error messages about the software configuration tool
H	Exit	To exit the configuration software tool

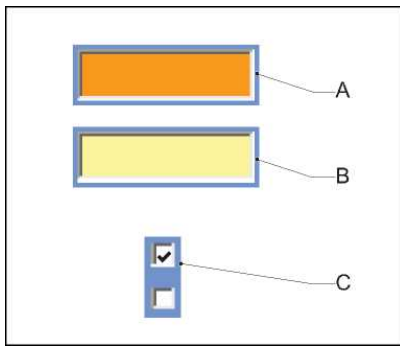

You can adjust the values in the yellow areas (A).

You cannot adjust values in the orange areas (B).

White selection boxes: if the box is marked, the item applies (C).

3.2 CCR status screen

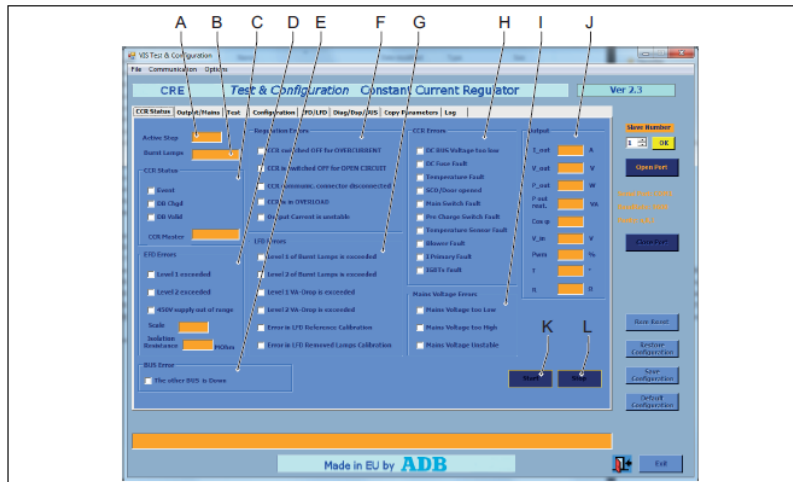

Description		
A	Active step	Shows the active brightness step of the selected equipment
B	Burnt lamps	Shows the number of burnt lamps in the series circuit
C	CCR Status	See CCR Status
D	EFD Errors	See EFD Errors
E	Bus Error	Only applies to a double J-Bus or Ethernet connection
F	LFD Errors	See LFD Errors
G	Regulation Errors	See Regulation Errors
H	CCR Errors	See CCR Errors
I	Mains Voltage Errors	See Mains Voltage Errors
J	Output	See Output
K	Start	To show the parameters of the selected slave equipment
L	Stop	To stop to show the parameters of the slave equipment

3.2.1 CCR Status

Item	Description
Event	An error event occurred
DB Chgd	A change was made to the database
DB Valid	The data in the database is up to date
CCR Master	<ul style="list-style-type: none"> • LOCAL SELECTOR: the master is in LOCAL mode • PC: the RS232 port of the master is active • BUS A. The J-BUS is active and the master is in REMOTE mode

3.2.2 EFD Errors

	Possible cause	Alarm type
Level 1 exceeded	The resistance to earth is less than level 1 (20 MOhm default value)	The red light on the equipment goes on
Level 2 exceeded	The resistance to earth is less than level 2 (2 MOhm default value)	
450V supply out of range	The 450 V EFD test voltage is missing	
Scale	Shows 0 for a 20 pA EFD scale and 1 for a 200 pA EFD scale	
Isolation resistance	Shows the isolation resistance value (0 to 500 MOhm)	

3.2.3 LFD Errors

	Possible cause	Alarm type
Level 1 of Burnt Lamps is exceeded	Minimum 3 broken lamps	The red light on the equipment goes on
Level 2 of Burnt Lamps is exceeded	Minimum 5 broken lamps	
Level 1 VA-Drop is exceeded	The output power goes below a preset level	
Level 2 VA-Drop is exceeded	The output power goes below a preset level	
Error in LFD Reference Calibration	The LFD reference calibration is not done or is not successful	
Error in LFD Removed Lamps Calibration	The LFD removed lamps calibration is not done or is not successful	

3.2.4 Regulation Errors

	Possible cause	Alarm type
CCR switched OFF for OVERCURRENT	<ul style="list-style-type: none"> The output current is more than $I_{max} + 5\%$ for minimum 4s The output current is more than $I_{max} + 20\%$ for minimum 0.4s 	<ul style="list-style-type: none"> The equipment automatically switches OFF Restart the equipment only after you have found the cause of the alarm
CCR switched OFF for OPEN CIRCUIT	The output circuit is interrupted. Connect the cable correctly before you restart the equipment	
Measure board connector disconnected	<p>There is no communication between the CPU PCB and the measure PCB</p> <p>Possible root causes:</p> <ul style="list-style-type: none"> The optical cable is disconnected The power supply cable is disconnected Malfunction of the measure PCB 	
CCR is in OVERLOAD	The load of the equipment is too high	
Output current is unstable	<p>The output current fluctuates or could not reach the requested value</p> <p>Possible root causes:</p> <ul style="list-style-type: none"> Load switching (E.g. Aglas, Brite) To much load on the series circuit 	

3.2.5 CCR Errors

	Possible cause	Alarm type
DC BUS Voltage too low	<p>Only for a three-phase equipment. The voltage on the DC bus does not reach the nominal value</p> <p>Possible root causes:</p> <ul style="list-style-type: none"> Malfunction of the IGBT The wiring is not connected properly 	<ul style="list-style-type: none"> The equipment automatically switches OFF Restart the equipment only after you have found the cause of the alarm
Temperature Fault	The temperature of the heat sink is too high	
SCO/Door opened	A front, rear and/or field connection panel is open	The red light on the equipment goes on
Main Contactor Fault	<p>The main contactor does not switch on when the microprocessor gives an 'on' command</p> <p>Possible root causes:</p> <ul style="list-style-type: none"> Malfunction of the main contactor Malfunction of the feedback of the contactor A faulty connection on the power supply PCB 	
Pre-Charge Contactor Fault	<p>The precharge contactor does not go on when the microprocessor gives an 'on' command</p> <p>Possible root causes:</p> <ul style="list-style-type: none"> Malfunction of the main contactor Malfunction of the feedback of the contactor A faulty connection on the power supply PCB 	

	Possible cause	Alarm type
Temperature Sensor Fault	There is fault in the temperature measurement circuit	<ul style="list-style-type: none"> The equipment automatically switches OFF
Blower Fault	One or more fans do not operate correctly	<ul style="list-style-type: none"> Restart the equipment only after you have found the cause of the alarm
I Primary Fault	There is a problem with the current after the IGBT	
IGBT Fault	<p>The IGBT test did not succeed after the 'ON step request'</p> <p>Possible root causes:</p> <ul style="list-style-type: none"> Malfunction of the IGBT. A faulty wiring between the CPU PCB and the IGBT PCB Malfunction of the IGBT PCB 	

3.2.6 Mains Voltage Errors

	Possible cause	Alarm type
Mains Voltage too Low	The input voltage is too low. This can lead to an over current situation	<ul style="list-style-type: none"> The equipment automatically switches OFF Restart the equipment only after you have found the cause of the alarm
Mains Voltage too high	The input voltage is too high	
Mains Voltage unstable	The input voltage is not stable	The red light on the equipment goes on

3.2.7 Output

Item	Description
I_out	Shows the output current
V_out	Shows the output voltage
P_out	Shows the output power
V_in	Shows the input voltage
Pwm	Shows the PWM

3.3 Output/Mains screen

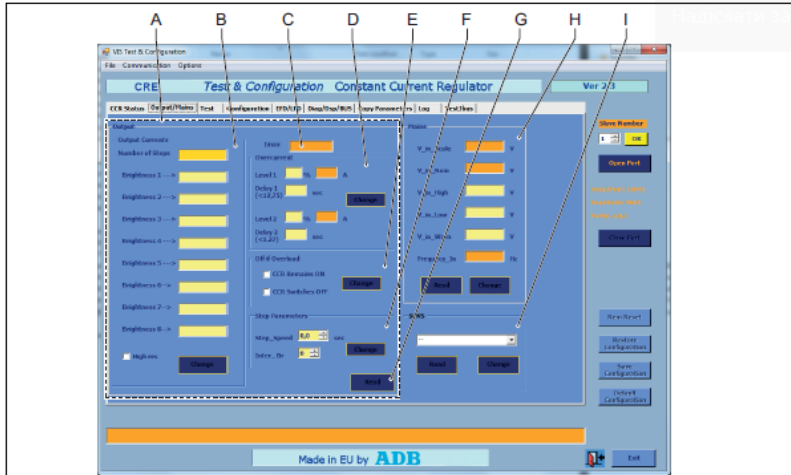

	Description	
A	Output screen part	See items B to F
B	Output currents	See Off if overload
C	Imax	Shows the maximum output current
D	Overcurrent	See Overcurrent
E	Off if overload	See Off if overload
F	Step parameters	See Step Parameters
G	Read	To read the actual Output parameters from the selected equipment
H	Mains	See Mains
I	SHVS	Not used

3.3.1 Output currents

Item	Description
Number of Steps	To select the number of brightness steps
Brightness 1 to 8	To adjust the current for each brightness step, accurate up to 25 mA
Change	To activate the values and to send them to the equipment

i Note

When you select less than 8 brightness steps, the steps higher than the highest step automatically get the current of the highest brightness step.

Example: When you select 4 brightness steps and you select 4.750 A for brightness step 4, brightness steps 5 to 8 are disabled and get 4.750 A current assigned automatically.

3.3.2 Off if overload

Item	Description
CCR Remains ON	To make sure that the equipment remains ON when the equipment is in overload state and the alarm comes up
CCR Switches OFF	To make sure that the equipment switches OFF when the equipment is in overload state and the alarm comes on
Change	To activate the values and to send them to the equipment

3.3.3 Overcurrent

Item	Description
Level 1 and Level 2	To set the percentage of the maximum of the two thresholds for overcurrent. The screen part also shows the actual current threshold values
Delay 1 and 2	To set the delay before the overcurrent alarm comes on, in s
Change	To activate the values and to send them to the equipment

3.3.4 Step Parameters

Item	Description
Step_Speed	To set the time that the equipment takes to change from one brightness step to another, in seconds (0 to 125 s)
Inter_Br	To define an intermediate brightness between steps
Change	To activate the values and to send them to the equipment

3.3.5 Mains

Item	Description
V_in_Scale	Shows the scale used to calculate the nominal voltage
V_in_Nom	Shows the nominal supply voltage
V_in_High	To adjust the supply voltage threshold above which the equipment restarts when switched OFF due to too low supply voltage
V_in_Low	To adjust the supply voltage threshold below which the equipment sounds an alarm and switches OFF
V_in_Warn	To adjust the voltage threshold above which the equipment sounds an alarm
Frequency_In	Shows the supply voltage frequency
Change	To activate the values and to send them to the equipment
Read	To read the actual Mains parameters from the selected equipment

3.4 Test screen

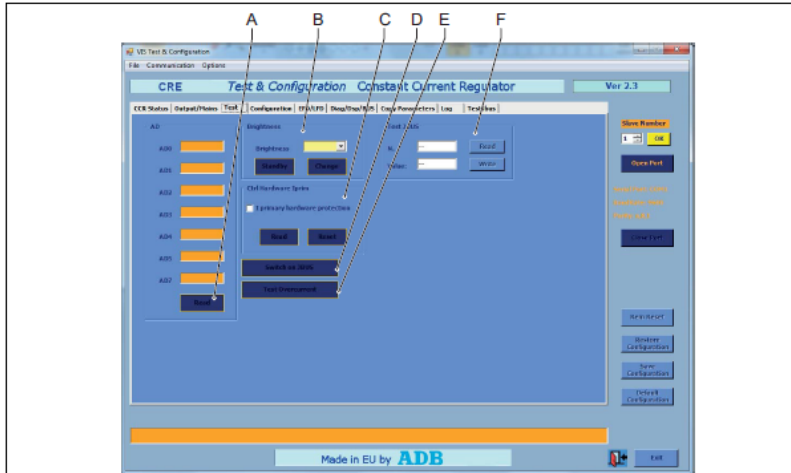

Description		
A	Read	To read the actual Analogue Data parameters (AD0 to AD7) from the selected equipment
B	Brightness	See Brightness
C	Ctrl Hardware Iprim	See Ctrl Hardware Iprim
D	Switch on JBUS	To enable the J-Bus serial port an to disable the RS232 serial port
E	Test Overcurrent	To start the overcurrent alarm test
F	Test JBUS	See Test JBUS

3.4.1 Brightness

Item	Description
Brightness	To select the step
Standby	To set the selected equipment to stand-by
Change	To activate the values and to send them to the equipment

3.4.2 Ctrl Hardware Iprim

Item	Description
I primary hardware protection	Shows if the primary current hardware protection is released. This is a read-only parameter
Reset	To reset the primary current hardware protection
Read	To read the actual primary current protection parameter from the selected equipment

3.4.3 Test JBUS

Item	Description
N.	To select the data line
Value	To select the test data value
Read	To read the actual JBUS parameters from the selected data line
Write	To send the selected test data to the selected data line

3.5 Configuration screen

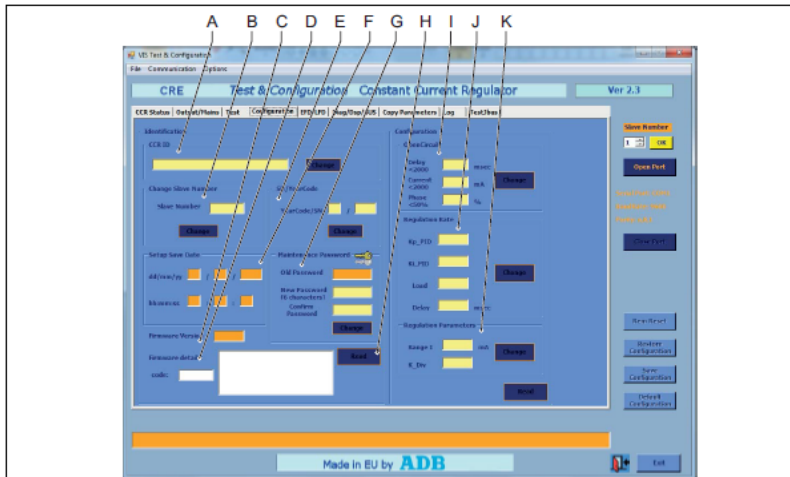

	Description
A	CCR ID See CCR ID
B	Change Slave Number See Change Slave Number
C	Firmware version Shows the firmware version of the selected equipment
D	Firmware details Shows a description on the firmware version of the selected equipment
E	SN/YearCode See SN/YearCode
F	Setup Save Date Shows the date and time of the latest save of the data of the selected equipment. The date and time are generated from the PC that is connected to the equipment
G	Maintenance Password See Maintenance Password
H	Read To read the actual configuration parameters from the selected data line
I	Open Circuit Do not use these parameters. There is a risk of damage to the equipment. Only ADB Safegate service engineers are allowed to use these parameters
J	Regulation Rate
K	Regulation Parameters

3.5.1 CCR ID

Item	Description
Blank field	To change the name of the field circuit that the equipment delivers power to. This name shows in the HMI
Change	To activate the value and to send it to the equipment

3.5.2 Change Slave Number

Item	Description
Slave Number	To adjust the slave number of the selected equipment
Change	To activate the value and to send it to the equipment

3.5.3 SN/YearCode

Item	Description
YearCode/SN	To change the production year and the serial number
Change	To activate the value and to send it to the equipment

3.5.4 Maintenance Password

Item	Description
Old Password	Shows the current maintenance password
New Password	To adjust the maintenance password
Confirm Password	Copy the adjusted maintenance password for confirmation
Change	To activate the value and to send it to the equipment

3.6 EFD/LFD screen

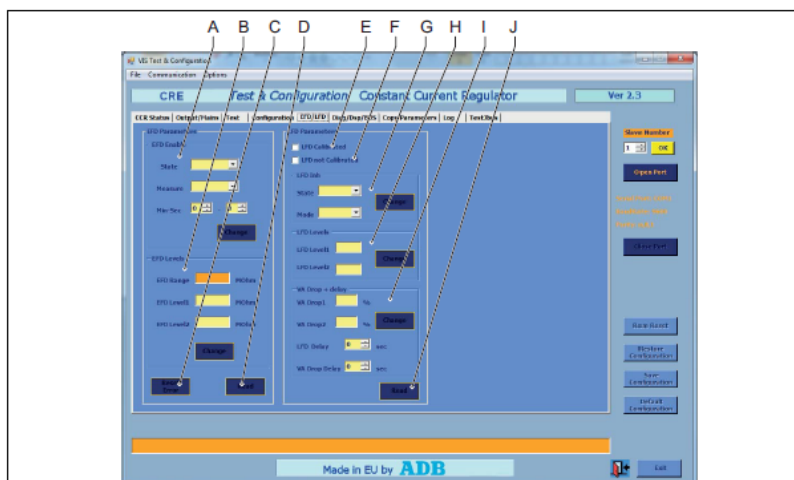

	Description	
A	EFD Enable	See EFD Enable
B	EFD Levels	See EFD Levels
C	Reset error	To reset the EFD error
D	Read	To read the actual EFD parameters from the selected equipment
E	LFD Calibrated	Shows if the LFD is calibrated
F	LFD not Calibrated	Shows if the LFD is not calibrated
G	LFD Inh	See LFD Inh
H	LFD Levels	See LFD Levels
I	VA Drop + delay	See VA Drop + delay
J	Read	To read the actual LFD and VA Drop parameters from the selected equipment

3.6.1 EFD Enable

Item	Description
State	To select if the EFD measurement is enabled or disabled
Measure	If the EFD measurement is enabled, you can choose between these values: <ul style="list-style-type: none"> • Interval: the interval between measurements is indicated in the Min-Sec field • Continuous: the equipment measure continuously. The Min-Sec field is not active
Min-Sec	To set the time between measurement if the measurement is set as interval
Change	To activate the value and to send it to the equipment

3.6.2 EFD Levels

Item	Description
EFD Range	Shows the maximum earth leakage value the equipment can measure
EFD Level 1	To adjust the insulation resistance below which the equipment gives the EFD Level 1 alarm
EFD Level 2	To adjust the insulation resistance below which the equipment gives the EFD Level 2 alarm
Change	To activate the value and to send it to the equipment

3.6.3 LFD Inh

Item	Description
State	To select if the LFD is enabled or not
Mode	To choose between different LFD modes: <ul style="list-style-type: none"> • Normal: both the LFD 1 and 2 Levels are active • Degraded: only LFD 2 Level is active
Change	To activate the value and to send it to the equipment

3.6.4 LFD Levels

Item	Description
LFD Level 1 and Level 2	To adjust the threshold above which the equipment gives the LFD Level 1 and Level 2 alarm
Change	To activate the value and to send it to the equipment

3.6.5 VA Drop + delay

Item	Description
VA Drop1 and Drop2	To adjust the threshold above which the equipment gives the VA Drop 1 and Drop 2 alarm
LFD Delay	To adjust the minimum time span after the error before the equipment gives the LFD Level 1 or Level 2 alarm
VA Drop Delay	To adjust the minimum time span after the error before the equipment gives the VA Drop 1 or Drop 2 alarm
Change	To activate the value and to send it to the equipment

3.7 Diag/Dsp/BUS screen

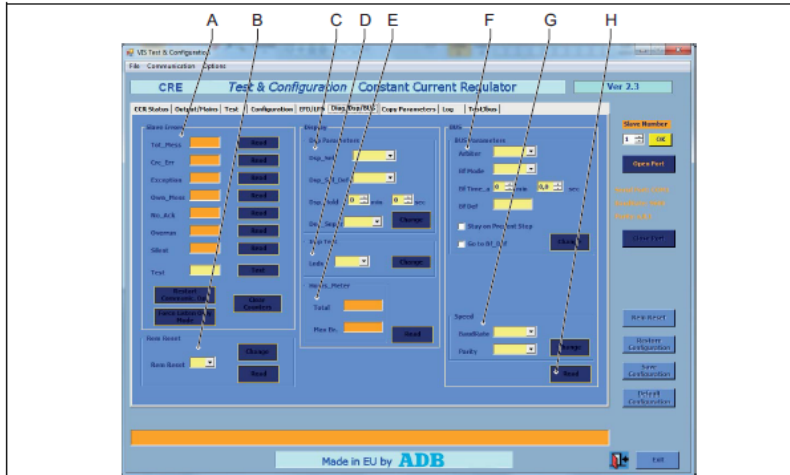

Description	
A	Slave errors See Slave Errors
B	Rem Reset See Rem Reset
C	Dsp parameters See Dsp Parameters
D	Imp Test See Imp Test
E	Hours_Meter See Hours_Meter
F	Bus Parameters <ul style="list-style-type: none"> • Arbiter: To set the signal source for remote control. To set a priority for different systems. If you set this parameter to disabled, remote control is not possible. • BF Mode: Use <i>normal</i> or <i>stop bar</i>. • BF Time: The time after which the equipment starts to use the default settings. • BF Def: To set default values that the equipment uses when the remote control (J-Bus) connection is down for longer than the time set in the menu. Leave this field blank or set a value from 1 to 8. • Select either <i>Stay on Prevent</i> step or <i>Go to Bf-Def</i>.
G	Speed See Speed
H	Read To read the actual J-Bus parameter of the equipments

Note To show the screen part with the bus parameters, select Options>Advanced.

3.7.1 Slave Errors

Item	Description
Read buttons	To read the actual slave error from the selected equipment
Tot_Mess	Shows the number of messages that the equipment received
Crc_Err	Shows the number of messages with checksum that the equipment received
Exception	Shows the number of messages with wrong commands that the equipment received
Own_Mess	Shows the number of messages that belong to the selected equipment
No_Ack	Shows the number of messages for which the equipment did not receive a reply

Item	Description
Overrun	Shows the number of messages with overrun that the equipment received
Silent	Shows the if the equipment replies to messages: <ul style="list-style-type: none"> • 0: the equipment replies to messages • 1: the equipment does not reply to messages
Test field	To test the communication. You can enter a number in the field to test
Test button	To test the communication with the value in the test field
Restart Communic.Opt	To set all counters to 0 and the silent value to 0
Force Listen Only Mode	To set the silent field to 1 and to force the equipment to reply to messages
Clear Counters	To set all counters to 0 but not to change the silent value

3.7.2 Rem Reset

Item	Description
Rem Reset	To enable or disable the Rem Reset button <ul style="list-style-type: none"> • 1: the Rem Reset button is enabled • 0: the Rem Reset button is disabled
Change	To activate the value and to send it to the equipment
Read	To read the actual Rem Reset parameter from the selected equipment

3.7.3 Dsp Parameters

Item	Description
Dsp_Sel	To select what the HMI shows optionally. You can choose from four parameters The HMI only shows the selected parameter <ul style="list-style-type: none"> • LAMP: the number of broken lamps • VA_Out: the VA output • VA_Out%: the percentage of the VA output • LMP_Test: to carry out a display test
Desp_Sel_Def	To select what the HMI shows optionally. You can choose from four parameters. The HMI shows the selected parameter, but only for the time indicated in the DSP_Hold field. <ul style="list-style-type: none"> • LAMP: the number of broken lamps • VA_Out: the VA output • VA_Out%: the percentage of the VA output • LMP_Test: to carry out a display test
Dsp_Hold	To adjust the time the HMI shows the optional parameter
Dec_Separ	To adjust the decimal separator for the UI (, or .)
Change	To activate the value and to send it to the equipment

3.7.4 Imp Test

Item	Description
LEDs	To carry out a test on the LEDs of the keyboard on the HMI. The LED adjacent to the DB9 connector comes on
Change	To activate the value and to send it to the equipment

3.7.5 Hours_Meter

Item	Description
Total	Shows the total time that the equipment is set to 'on' in h
Max Br.	Shows the time that the equipment operates at the maximum brightness step in h
Read	To read the actual hours parameters from the selected equipment

3.7.6 Rem_Reset_Circuit_selector

Item	Description
Circuit selector	When the boxed is checked, the circuit selector will be reset
Change	To activate the value and to send it to the equipment
Read	To read the actual Rem Reset parameter from the selected equipment

3.7.7 Speed

Item	Description
BaudRate	To adjust BaudRate of the J-Bus connection between the equipments
Parity	To adjust the parity of the J-Bus connection between the equipments
Change	To activate the value and to send it to the equipment. Do not change the speed parameters when you connect the equipment with the ethernet line

3.8 Copy Parameters screen

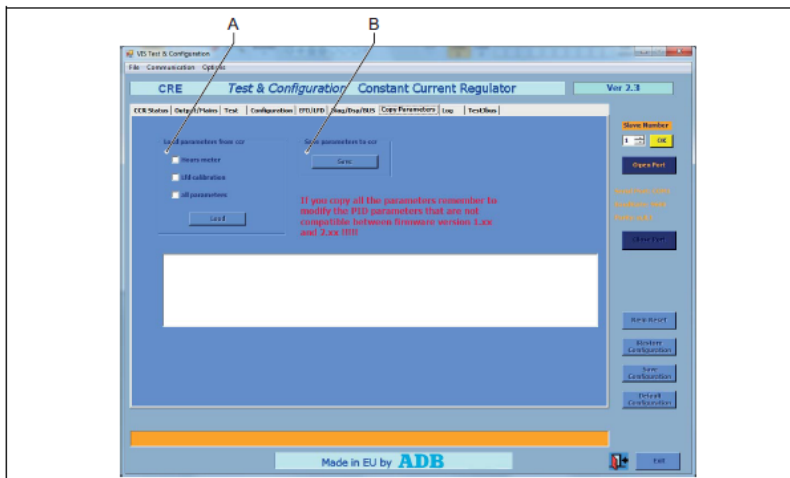

	Description
A Load parameters from ccr	See Load parameters from CCR
B Save	To save the parameters from the PC to the selected equipment

3.9 Log screen

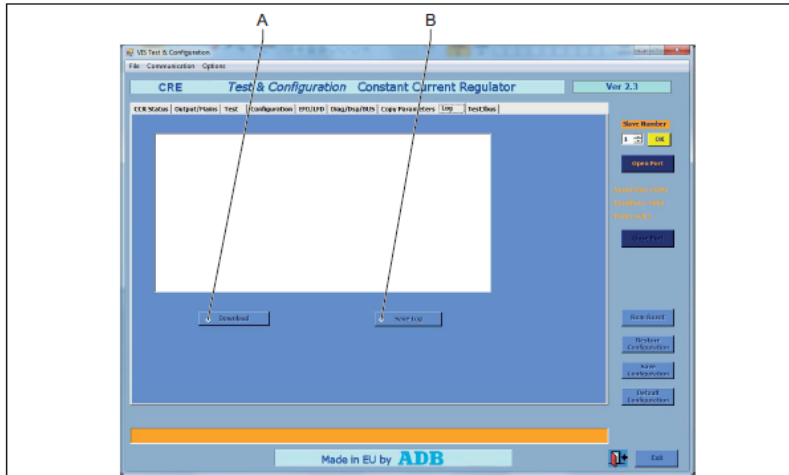

Description

A	Download	To show the history file of the selected equipment in the Log screen
B	Save Log	To save the log file to the PC

3.10 Test JBus screen

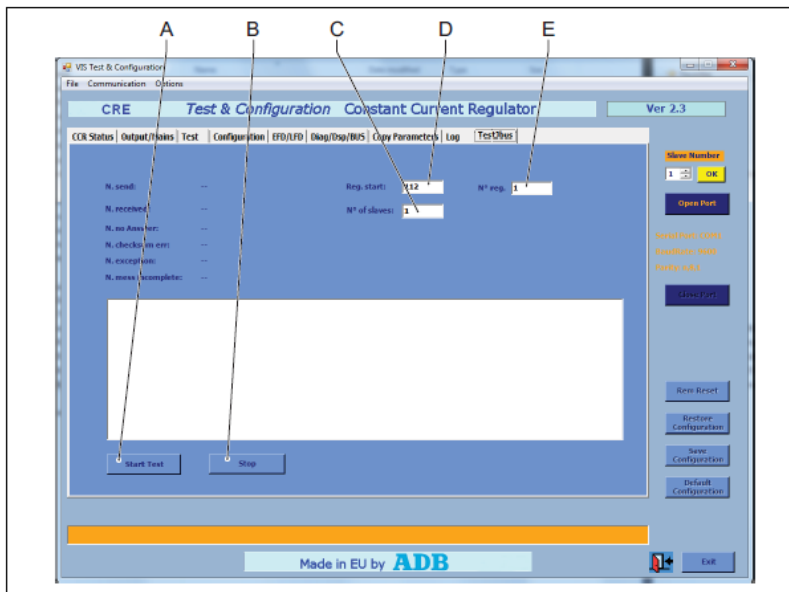

Description

A	Start Test	To start the test
B	Stop	To stop the test
C	No. of slaves	Shows the number of slaves
D	Reg. start	
E	No. of reg	

4.0 Install and operate the configuration software tool

4.1 Install the configuration tool software

System requirements

- PC with Microsoft Windows 2000, XP operation system, or later
- At least 50 Mbytes free disk space
- 1 free serial communication (COM) port, or a virtual serial communication port over a USB bridge or a PCMCIA card
- PC user account with either administrator or power user rights

Move the WINCCR.exe file from the CD-ROM to the hard drive of the PC.

4.2 Start the configuration software tool

Activate the serial port, if applicable

1. On the HMI, push the **MENU** button to go to the Main menu.
2. Push the **SER/JBUS** button to go to the **SER/JBUS** screen.
3. Push the **SERIAL** button to activate the serial port.

Configure the ethernet port, if applicable

1. On the HMI, push the **MENU** button to go to the Main menu.
2. Push the **MORE** button to go to the **Mode** screen.
3. Push the **ETHERNET CONFIGURATION** button to configure the ethernet port.

Find the slave number of the equipment

1. On the HMI, push the **ESC** button to go to the Main menu.
2. Push the **OPTIONS** button to go to the **Options** menu.
3. Push the **SLVNUM** button to show the slave number.
4. Note the slave number. You will need it for reference later.

Connect the serial cable, if applicable

1. Switch **OFF** the equipment. See [Switch OFF the equipment](#).
2. Connect the extension cable to the dongle (A) and to the serial communication port of the PC (B).

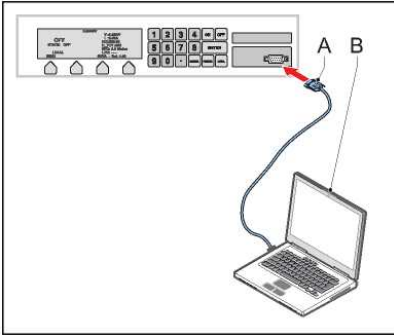

Connect ethernet cable, if applicable

1. Switch **OFF** the equipment. See [Switch OFF the equipment](#).
2. Connect the ethernet cable (B) to the equipment (A) and to the PC (C).

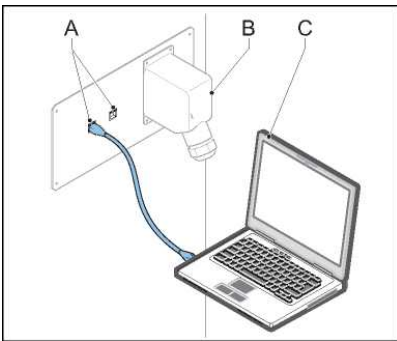

Configure the remote control ethernet connection

1. Make sure that the IP range of the PC is in the same range as the device.
2. Access the web control interface of the device.
3. From the **Network Settings** control panel, set the IP address, Netmask, and IP configuration to the values of the network that the Ethernet board uses.
4. From the **Serial Settings** control panel, make sure that the serial parameters have the values that follow:
 - Baud Rate: 9600
 - Data Bits: 8
 - Stop Bits: 1
 - Parity: None
5. From the **Operating Settings** control panel, make sure that the Port=01 parameters have the values that follow:
 - Operation mode: TCP Server Mode
 - TCP alive check time: 0
 - Inactivity time: 5000
 - Max connection: 1

6. Make sure the **Data Packing** parameters have the values that follow:
 - Delimiter 1: 0: Do not select Enable
 - Delimiter 2: 0: Do not select Enable
 - Force transmit: 10
7. Make sure the **TCP Server Mode** parameters have the values that follow:
 - Local TCP port: 502
 - Do not select Apply the above settings to all serial ports
8. From the **Serial Command Mode** control panel, make sure the serial parameters have the values that follow:
 - Trigger Setting: HW Trigger
 - SW Trigger Character: 2B 2B 2B

Start software

1. Switch the equipment **ON**.
2. Click the WINCCR.exe file in the directory where you installed the software. The configuration tool opens on the CCR Status screen.

Set up the serial port, if applicable

1. Select the menu **Communication**.
2. Select the applicable serial communication port (COM).



Note

The baud rate and parity settings for the communication between the PC and the equipment must be the same. For the dongle, the default baud rate is 9600 and the default parity setting is None.

3. Push the OK button to confirm the settings.
4. Push the Open Port button to open the selected serial port.
 - If the settings are correct, the yellow OK button is enabled and the bottom bar shows the message 'Port opened'.
 - If the settings are not correct, the bottom bar shows an error message.

Set up the Ethernet port if applicable

1. Select the menu Communication>Ethernet.
2. Select the applicable IP address and Port.
3. Push the **OK** button to confirm the settings.
4. Push the **Open Port** button to open the selected serial port.
 - If the settings are correct, the yellow OK button is enabled and the bottom bar shows the message 'Port opened'.
 - If the settings are not correct, the bottom bar shows an error message.

4.3 Monitor the data of an equipment

Select the equipment

1. Select the slave number of the equipment you want to monitor.
2. Push the **OK** button.

Start monitoring

1. Select the CCR status screen. See [CCR status screen](#).
2. Push the **Start** button. The screen shows the data of the selected equipment.

Stop monitoring

- Push the **Stop** button. The screen no longer shows the data of the selected equipment.

4.4 Stop the configuration software tool

1. Serial connection: Disconnect the extension cable from the dongle and the PC connector of the equipment.
2. Ethernet connection: Disconnect the ethernet cable from the PC and the equipment.

5.0 Commissioning

Main commissioning procedure

1. Do the first start-up. See [First start-up](#).
2. Calibrate the Lamp Fault Detection (LFD) module. See [Calibrate Lamp Fault Detection \(LFD\)](#).
3. Adjust the number of available brightness steps. See [Adjust number of used brightness steps](#).
4. Configure the remote control interface (option). See [Remote control configuration: multiwire \(option\)](#), [Remote control configuration: J-Bus \(option\)](#), or [Remote control configuration: ethernet \(option\)](#), depending on the hardware.

5.1 First start-up

The equipment stores the last request after a power cycle. This means that when the equipment is switched **ON**, it starts to produce the same output current that was valid before the equipment was switched **OFF**.

When you start up the equipment for the first time, the powering-down status is unknown. This procedure allows you to prevent the equipment from producing the output current at first start-up.

5.1.1 Procedure

1. Measure the input voltage. See [Measure input voltage](#).
2. Measure the output current in short circuit. See [Measure output current in short-circuit](#).
3. Measure the resistance and the insulation resistance of the series circuit. See [Measure insulation resistance of series circuit](#).
4. Measure the output current to the series circuit. See [Measure the output current to the series circuit](#).

5.1.2 Measure input voltage

Prepare

1. Make sure that the manual switch is in the **OFF** position. See [Switch OFF the power supply](#).
2. Remove the lower rear panel. See [Remove panels](#).
3. Set the manual switch to the **ON** position.
4. On the HMI, push the **Local** button. The screen now shows the state **LOCAL**.
5. Push the **OFF** button. The equipment goes to the mode **OFF**.

Measure

1. Measure the input voltage on the input terminals (A). Use a True RMS Multimeter.
2. Examine if the voltage is in accordance with:
 - The nameplate of the equipment.
 - Local regulations.



CAUTION

Excessive input voltage can damage the equipment.

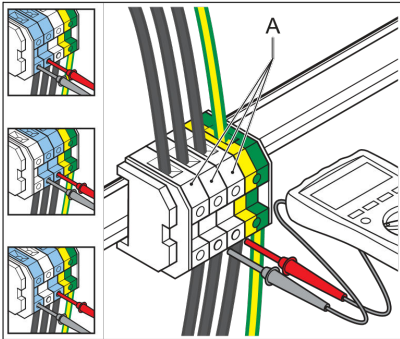

Finish

1. Switch off the power supply. See [Switch OFF the power supply](#).
2. Install the lower rear panel.

5.1.3 Measure output current in short-circuit

1. Make sure that all power to the equipment is **OFF**. See [Switch OFF the power supply](#).
2. Put the output in short-circuit. For SCB, see [Put SCB in short-circuit](#). For SCO, see [Put SCO in short circuit](#).
3. Measure the output current in short-circuit. See [Measure the output current in short circuit](#).
4. Make sure that all power to the equipment is **OFF**. See [Switch OFF the power supply](#).
5. If you use an SCB: Remove the separate piece of cable and connect the series circuit cables. See [Put SCB in short-circuit](#).
6. If you use an SCO: set the SCO to mode A. See [Operation mode](#).

5.1.4 Put SCB in short-circuit

Strip cables

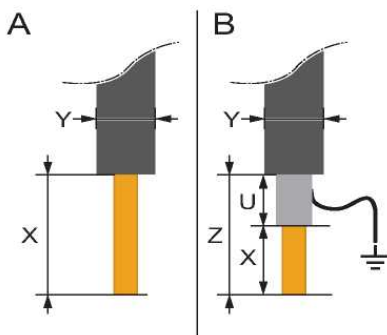

Strip a separate piece of series circuit cable at both ends.

- A: unscreened cables
 - X: 16 mm
 - Ø Y: less than or equal to 18 mm
- B: unscreened cables
 - X: 16 mm
 - Ø Y: less than or equal to 18 mm
 - U: 11 mm
 - Z: 77 mm

Remove the box panel of the SCB

1. Loosen the screws (A).
2. Remove the box panel (B).

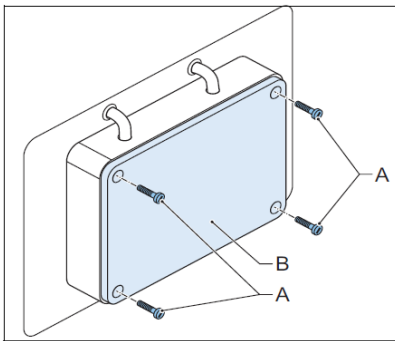

Short circuit SCB with separate piece of output cable

1. Disconnect the series circuit cables.
2. With the separate piece of output cable (B), short-circuit the output terminals (A).
3. Install the box panel.

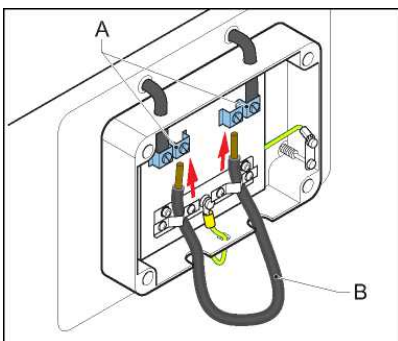

5.1.5 Put SCO in short circuit

Set the SCO to mode C. See [Operation mode](#)

5.1.6 Measure the output current in short circuit

Connect AC True RMS multimeter (SCB)

- Connect the current clamp of an AC True RMS multimeter (B) to the short-circuited cable (A).

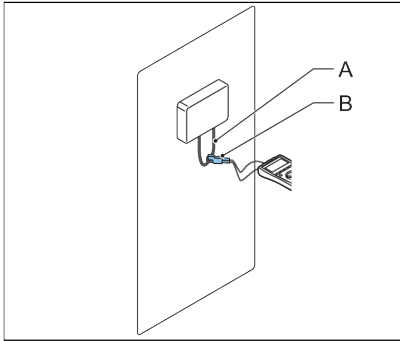

Connect AC True RMS multimeter (SCO)

- Connect the current clamp of an AC True RMS multimeter (B) to the output cable (A).

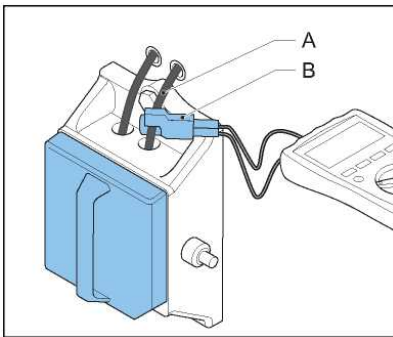

Measure output current

1. Switch **ON** the equipment and set it to **LOCAL** mode. See [Operation](#).
2. Select the step 6.6 A.
3. Read the output current value from the AC True RMS Multimeter.
4. Repeat the previous steps and examine the output current value for each brightness step. Check each brightness step separately from the highest to the lowest level.

5.1.7 Measure resistance and the insulation resistance of series circuit

1. Prepare the series circuit. For SCB, see [Prepare with SCB](#). For SCO, see [Prepare with SCO](#).
2. Measure the resistance of the series circuit. See [Measure resistance of series circuit](#).
3. Measure the insulation resistance of the series circuit. See [Measure insulation resistance of series circuit](#).
4. Calculate minimum insulation resistance of series circuit. See [Calculate minimum insulation resistance of series circuit](#).
5. Calculate resistance of series circuit See [Calculate resistance of series circuit](#).
6. Complete the activities. See [Complete the measurement](#).

5.1.8 Prepare with SCB

Set power to OFF

- Make sure that all power to the equipment is **OFF**. See [Switch OFF the power supply](#).

Remove the box panel

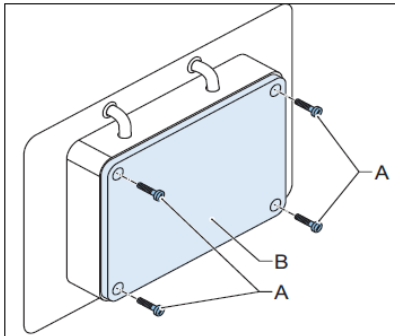

1. Loosen the screws (A).
2. Remove the box panel (B).

Discharge the output terminals

1. Discharge the output terminals.
2. Completely remove the series circuit cables, also the shielding, if applicable.

5.1.9 Prepare with SCO

Set power to OFF

1. Make sure that all power to the equipment is **OFF**. See [Switch OFF the power supply](#).
2. Set the SCO to mode C. See [Operation mode](#). The output terminals are now discharged.

Remove cover

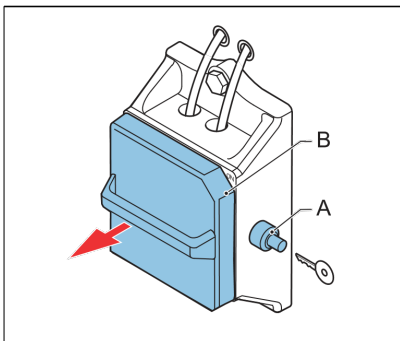

1. Open the lock (A).
2. Remove the cover (B). Use the handle.

Remove series circuit cables

- Completely remove the series circuit cables, also the shielding, if applicable.

5.1.10 Measure resistance of series circuit

Measure the resistance: measure on the ends of the series cable (A). Use a multimeter (B), in accordance with local regulations.

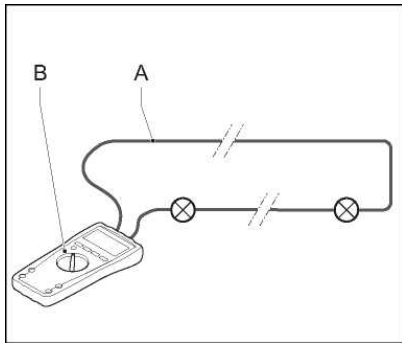

5.1.11 Measure insulation resistance of series circuit

1. Join the ends of the series circuit cables (C).
2. Measure the insulation resistance of the series circuit. Use the insulation tester (E). Megger 5000 V or 10000 V, in accordance with local regulations.
 - A: when the series circuit cable is not shielded
 - B: when the series circuit cable is shielded. Measure the earth on the shield (D).

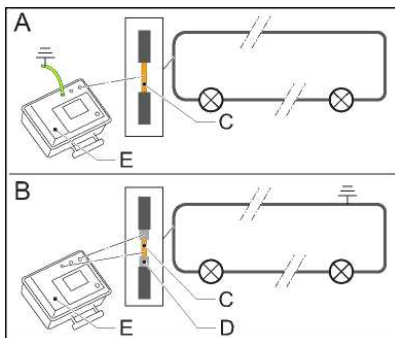

5.1.12 Calculate minimum insulation resistance of series circuit

Table 8: Theoretical insulation resistance for the series circuit

Item	Maximum insulation resistance current (standard: ICAO, part 5, § 3.9.4.7) [µA]
Series transformer	2
100 m of cable with standard number of connectors	1

Example: a runway center-line circuit with 133 light fixtures with a total length of the series circuit of 8 km.

- Allowed insulation resistance current for the transformers is $133 \times 2 = 266 \mu\text{A}$
- Allowed insulation resistance current the cable is $80 \times 1 = 80 \mu\text{A}$
- Total allowed insulation resistance current for this circuit is $266 \mu\text{A} + 80 \mu\text{A} = 346 \mu\text{A}$
- When you test with 5000 V, according to Ohms law, the minimum resistance is 14 MOhm.

5.1.13 Calculate resistance of series circuit

$$R_{\text{prim}} = \rho \times L/A + y \times 0.1212$$

Where:

- R_{prim} = resistance of the series circuit in Ohm
- $\rho = 18 \times 10^{-3}$ (Ohm x mm²)/m
- L = length of the circuit in m
- A = section of the cable in mm²
- y = number of series transformers in the circuit

Example:

circuit length is 8000 m

cable section is 6 mm²

number of series transformers is 122

Then $R_{\text{prim}} = (18 \times 10^{-3}) \times 8000/6 + 122 \times 0.1212 = 36.7$ Ohm

5.1.14 Complete the measurement

1. Make sure that the measured and the calculated values match and that all the values are in accordance with all local safety regulations.
2. Connect the series circuit cables to the equipment.
3. Install the cover or the box panel.

5.1.15 Measure the output current to the series circuit

Prepare

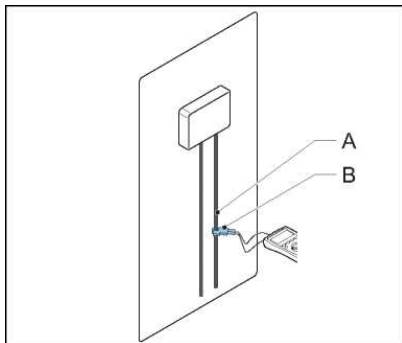

1. Make sure that the series circuit is measured and approved. See [Measure resistance and the insulation resistance of series circuit](#).
2. Make sure that all power to the equipment is **OFF**. See [Switch OFF the power supply](#).
3. Make sure that the series circuit is connected.
4. Connect an AC current clamp (B) to the series circuit cable (A).

Measure

1. Switch **ON** the equipment and set it to **LOCAL** mode. See [Operation](#).
2. Select the step 6.6 A.
3. If the output current does not reach 6.6 A, change the series circuit configuration before you proceed. This indicates that the equipment is too small for the load.
4. Compare the output current reading on the HMI with the reading on the True RMS Multimeter.
5. Examine if the output current readings are in accordance with local regulations. If not, do not continue.

Check brilliancy level

1. Examine if all light fittings have the same brilliancy level. Go to the runway area to make a visual inspection.
2. Examine all the brightness steps separately. Go through the whole procedure for each brightness step.

Finish

1. Wait for approximately 30 minutes and make sure that the equipment works correctly.
2. Make sure that all power to the equipment is **OFF**. See [Switch OFF the power supply](#).

5.2 Calibrate Lamp Fault Detection (LFD)

Follow this procedure to make sure that the equipment indicates the correct number of broken lamps. See [Input filter](#) for the accuracy of the LFD.



CAUTION

The LFD module does not work if the series circuit includes these types of lights:

- LED lights without the monitoring option
 - PVO/PVL lights (guidance signs)
 - WIGWAG (runway guard lights)
-

Make sure that all lamps in the series circuit operate

1. Make sure that the equipment is connected to the series circuit.
2. Switch **ON** the equipment and set it to **LOCAL** mode. See [Preliminary checks](#).
3. Set the equipment to the highest brightness step. See [Checks and measurements](#).
4. Examine if all light fittings light up. Go to the runway area to make a visual inspection.
5. Push the **OFF** button on the UI.

Select LFD calibration

1. On the HMI, push the **Options** button to go to the **Calibrate Lamp Fault Detection** menu.
2. Push the **LFD** button. The HMI prompts you to do the calibration.
3. Push the **Yes** button. The HMI prompts you regarding the number of burnt lamps (0 - 99).
4. Select '0', no broken lamps.
5. Wait until the equipment shows the Main screen. See [Display overview: Main screen](#)

Remove lamps

1. Make sure that all power to the equipment is **OFF**. See [Switch OFF the power supply](#).
2. Earth the series circuit
 - With the SCO. See [Use Series CutOut \(SCO\)](#)
 - With an earthing wire on the SCB
3. Remove the desired number of lamps in the field.



Note

Choose the number of lamps in function of the alarm level you use. By default, 8 to 10 lamps.

4. Switch **ON** the equipment and set it to **LOCAL** mode. See [Operation](#).

Set number of removed lamps

1. On the HMI, push the **Options** button to go to the **Options** menu.
2. Push the **LFD** button. The HMI prompts you to do the calibration.
3. Push the **Yes** button. The HMI prompts you regarding the number of burn lamps (0 - 99).
4. Enter the number of removed lamps.
5. Wait until the equipment shows the Main screen. See [Display overview: Main screen](#).

Examine the LFD measurement

1. Make sure that all power to the equipment is **OFF**. See [Switch OFF the power supply](#).
2. Connect a number of lamps, but not all.
3. Switch **ON** the equipment and set it to **LOCAL** mode. See [Operation](#).
4. Make sure that the number of lamps removed corresponds to the LFD reading on the main menu.
5. Make sure that all power to the equipment is **OFF**. See [Switch OFF the power supply](#).
6. Leave the equipment **OFF** for 10 seconds.
7. Repeat the previous steps and connect the rest of the lamps.

Set alarm level

- With the configuration software tool, set the LFD Level1 and LFD Level2 alarm levels. See [EFD/LFD screen](#).

5.3 Remote control configuration: multiwire (option)

Examine if the equipment is set to multiwire remote control

1. On the HMI, push the **MENU** button to go to the Main menu.
2. Push the **MAINT** button to go to the Maintenance menu. See [Maintenance menu](#).
3. Push the **MORE** button.
4. Push the → or ← buttons until the HMI shows the remote control mode.
5. Make sure that the remote control mode is 'MULTIWIRE'.
6. If necessary, adjust the remote control mode.

Examine or adjust the input and output signals function assigned to terminals

1. Push the → or ← buttons until the HMI shows the multiwire configuration.
2. Check and adjust the signals if necessary. See [Maintenance menu](#).



Note

For the standard multiwire configuration, see [Remote Control PCB](#).
You can only adjust the signals 6 to 15. The other signals are fixed.

5.4 Remote control configuration: J-Bus (option)

Configure the slave number

1. On the HMI, push the **MENU** button to go to the Main menu.
2. Push the **OPTIONS** button to go to the Options menu.
3. Push the **SLVNUM** button to set the slave number of the equipment.
4. Push the **SAVE** button to save the slave number to the equipment.

Examine and adjust the configuration, if necessary

1. On the HMI, push the **ESC** button a number of times until the UI shows the Main menu.
2. Push the **MAINT** button to go to the Maintenance menu. See [Maintenance menu](#).
3. Push the **MORE** button.
4. Push the → or ← buttons until the HMI shows the remote control mode.
5. Set the remote control mode to 'JBUS'.
6. Set the applicable J-Bus protocol. The default value is 'MCR2'.
7. Set the J-Bus mode to '485'.

5.5 Remote control configuration: ethernet (option)

Examine the remote control mode and adjust if necessary

1. On the HMI, push the **MENU** button to show the Main menu. See [Display overview: Main screen](#).
2. Push the **MAINT** button to go to the Maintenance menu. See [Maintenance menu](#).
3. Push the **MORE** button.
4. Push the → or ← buttons until the HMI shows the remote control mode.
5. Set the remote control mode to 'JBUS'.
6. Set the applicable J-Bus protocol. The default value is 'MCR2'.
7. Set the J-Bus mode to 'Ethernet'.

Examine the ethernet configuration and adjust if necessary

1. Push the → or ← buttons until the HMI shows the ethernet configuration.
2. Examine the parameters and adjust if necessary.
3. If you use a double ethernet connection, push the DOWN button until the HMI shows the ethernet configuration of the second ethernet connection.
4. Examine the parameters and adjust if necessary.

6.0 Operation

6.1 Switch ON the equipment

When you switch **ON** the equipment, it starts to produce the same output current that was valid before the equipment was switched **OFF**.

To set a different output current, select another brightness step. See [Select brightness step](#). For more information on the produced output currents, see [Used brightness steps](#).

A prerequisite for this procedure is that the equipment is switched off.

1. Set the manual switch (A) to the **ON** position.
 - The equipment starts to produce the same output current that was valid before the equipment was switched **OFF**
 - The HMI lights up
 - The equipment starts in the same mode as it was stopped: Local or Remote mode



WARNING

High voltage can be present on the system.

2. If the UI shows that the equipment is in the state **OFF**, push the **ON** button. The HMI shows the state **ON**.
3. To switch between Local and Remote mode, see [Switch between local and remote mode](#).

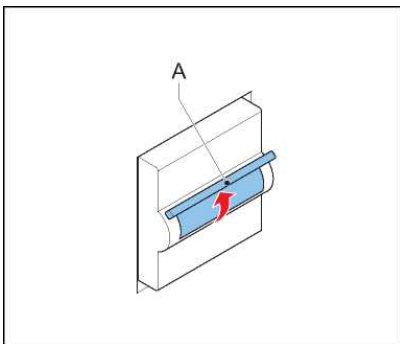

6.2 Switch OFF the equipment

1. On the HMI, push the **Local** button. The screen now shows the state **LOCAL**.
2. Push the **OFF** button. The equipment goes to the mode **OFF**.
3. Switch **OFF** the power supply. See [Switch OFF the power supply](#).

6.3 Switch OFF the power supply

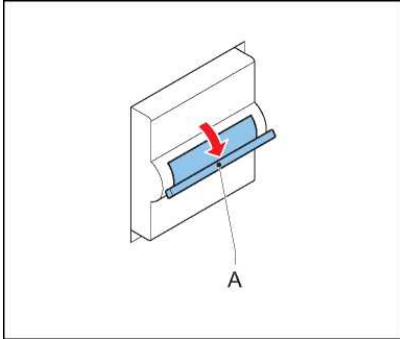

1. Set the manual switch (A) to the **OFF** position.
2. Open the main switch on the main distribution board.
3. Disconnect the equipment from the series circuit.

6.4 Switch between local and remote mode

To control the equipment through the HMI, switch to the local mode.

To control the equipment with the remote control system, switch to the remote mode.

1. For Local mode, push the **LOCAL** button on the HMI. The HMI now shows the mode **LOCAL**.

**Note**

The keypad keys on the HMI only operate when the equipment is in **Local** mode.

2. For Remote mode, push the **REMOTE** button on the HMI. The UI now shows the mode **REMOTE**. You can change the brightness step with the remote control device.

6.5 Select brightness step

1. Make sure that the equipment is powered **ON**, is in the **ON** state and in **Local** mode. See [Operation](#).
2. To select a brightness step, push the corresponding number on the keypad. The equipment immediately starts to produce the chosen brightness.

6.6 Adjust number of used brightness steps

1. Use the configuration software tool. See [Output/Mains screen](#). For information on the used brightness steps, see [Used brightness steps](#).
2. Examine all brightness steps one by one. See [Select brightness step](#) . Examine if all light fittings have the same brilliancy level. Go to the runway area to make a visual inspection.

6.7 Alarms

The HMI only shows information about errors that the equipment can detect. The equipment does not detect all possible errors. You have to observe if the equipment operates correctly.

Local mode

An alarm occurs, the equipment switches **OFF** automatically.

- If you need to switch off the power supply to remove the cause of the alarm: The equipment starts to produce the same output current that was valid before the equipment was switched **OFF**.
- If you do not need to switch off the power supply to remove the cause of the alarm: The equipment remains in the state **OFF**. Only after you reset the alarm and push the **ON** button, does the equipment start to produce the same output current that was valid before the equipment was switched **OFF**.

Remote mode

An alarm occurs, the equipment switches **OFF** automatically.

- If you need to switch off the power supply to remove the cause of the alarm: The equipment starts at the actual multiwire/J-Bus command.
- If you do not need to switch off the power supply to remove the cause of the alarm: After you reset the alarm, the equipment automatically goes to the actual multiwire command.

Reset an alarm

1. If the HMI does not show the alarm, push the **Menu** button to go to the Main Menu.
2. To go to the Alarms menu push the **Alarms** button.
3. To reset the alarm push the **Reset** button.

Clear the error list

1. On the HMI, push the **Menu** button to go to the Main Menu.
2. Push the **Alarms** button to go to the Alarms menu.
3. Push the **Clear alarms** button. The equipment clears the error list.

6.8 Use Series CutOut (SCO)

6.8.1 Operation mode



WARNING

Always wear protective gloves and shoes when working with the equipment or series circuit.

The SCO has three operation modes:

Description	Mode A	Mode B	Mode C
Purpose	Normal operation Equipment delivers current to the connected series circuit	Maintenance operation Equipment or series circuit can be serviced safely	Measurement possible The series circuit insulation relative to ground can be measured
Diagram			
Cover placement¹			
Handle position	Horizontal	Turned 90 degrees counter clockwise from position A	Turned 90 degrees clockwise from position A
Series circuit	Connected to the equipment	Shorted and grounded	Disconnected from equipment, shorted and connected to measurement terminal
Equipment	Delivers current to the series circuit	Shorted and grounded	Shorted and grounded
Microswitch²	Activated. Equipment is ON	Not activated. Equipment is OFF	Activated. Equipment is ON

Notes

¹ Only the three positions shown can be used. In another position, the cover fits correctly.

² When the cover is closed, the micro switch is activated. When the cover is open, the microcircuit is deactivated and the equipment shuts down.

6.8.2 Adjust operation mode

Remove the cover

1. Open the lock (A).
2. Remove the cover (B). Use the handle.

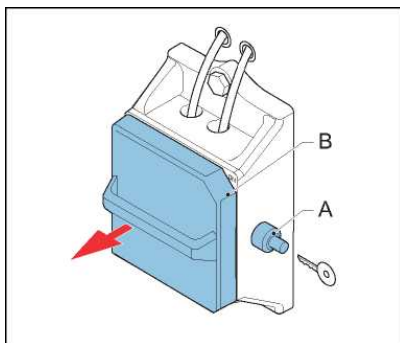

Set operation mode

1. Install the cover (B). See the cover placement in [Operation mode](#).
2. Close the lock (A).

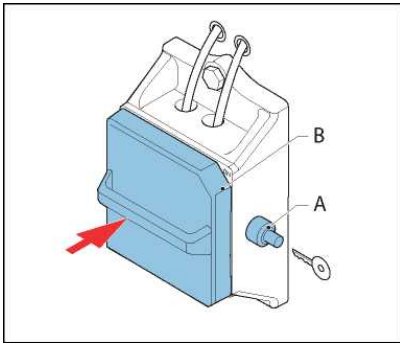

6.9 Operation mode

A series circuit with non-linear loads can be unstable. If the system is unstable, follow the procedure below.

i Note The equipment automatically detects if the inductive mode is required. The alarm message '**DC BUS VOLTAGE TOO HIGH**' means that the series circuit is unstable.

1. On the HMI, push the **MENU** button to go to the Main menu.
2. Push the **OPTIONS** button to go to the Options menu.
3. Push the **MODE** button to go to the Mode menu.
4. Select the applicable mode: **Normal** is the factory default. **Inductive** is for cases where the current regulation is under the influence of inductive load and becomes unstable. The HMI now shows the Main screen.

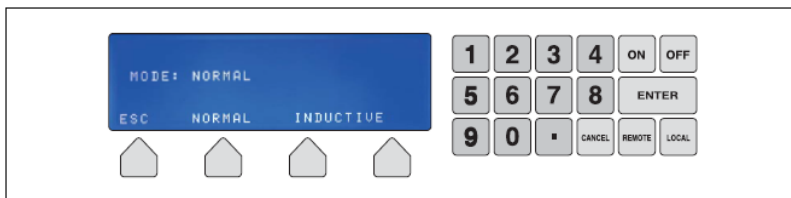

i Note The equipment has these limitations in inductive mode:

- The power is limited to 85%
 - The LFD measurement is not active
 - In normal mode the equipment limits all current peaks higher than 7 A in less than 10 ms, in inductive mode the current peak can reach 9 A
 - The output waveform is not a perfect sinusoidal wave.
-

7.0 Troubleshooting



WARNING

Do not troubleshoot unless you have read and understood all the information in the chapter [Safety](#) and you are qualified to work on high-voltage systems.

- Set the equipment to **Local** mode
- Set the equipment to the brightness step **OFF** before you examine the series circuit
- Turn **Off** the main switch of the equipment

If you do not follow the steps above, an increase of the power input can start an on cycling and restart the equipment. This results in a possible lethal output voltage.

7.1 Preliminary checks

Before you do any adjustments on the equipment, check:

- the alarm and back-indication signals on the display and/or remote control
- if the power supply to the equipment is within the acceptance limit
- if the fused input switches and auxiliary fuses are operational
- if the input fuses and auxiliary fuses work normally
- if all connectors are correctly in place
- that no components show burned marks.
- if the input circuit breaker is in the 'open' position
- wires are not interrupted or damaged.

7.2 Troubleshooting guide



Note

For a list of errors, see [CCR status screen](#).

7.2.1 Fault: Equipment does not turn ON

Table 9: Equipment does not turn ON

Problem	Possible cause	Possible solution
No display indications	A problem with the power supply on the diode bridge PCB	<ul style="list-style-type: none">• Examine the transformer on the diode bridge• If necessary, replace the IGBT power bridge that contains the diode bridge PCB
		See Diode bridge + sensing PCB (EPS476 / EPS507) replacement, small and stackable cabinet
		<ul style="list-style-type: none">• Examine the external 400 VAC/24VAC transformer• Replace the external transformer, if necessary
	The main switch is damaged	Replace the main switch. See Manual switch replacement
	The input line filter is damaged	Replace the line filter. See Line filter replacement
	The main contactor is damaged	Replace the main contactor. See Main contactor replacement, small cabinet or Main contactor replacement, big cabinet
		Replace the power supply PCB. See Power supply PCB (EPS480) replacement
		Replace the CPU PCB. See CPU PCB (EPS479) replacement

7.2.2 Fault: Equipment does not go to the ON state

Table 10: Equipment does not turn ON

Problem	Possible cause	Possible solution
Local mode: <ul style="list-style-type: none"> The display shows an alarm The red lamp on top of the equipment goes on 	One of the panels is open	Close the panel <ul style="list-style-type: none"> Examine the fuses on power supply PCB Replace the fuses if necessary. See Fuses on the power supply PCB (EPS480) replacement
Remote mode: <ul style="list-style-type: none"> The red lamp on top of the equipment goes on 	The main contactor is enabled when the equipment is in the OFF state when there is no command from the CPU PCB. Or The main contactor is not enabled when there is a command from the CPU PCB	<ul style="list-style-type: none"> Examine the CPU PCB Replace the CPU PCB if necessary See CPU PCB (EPS479) replacement <ul style="list-style-type: none"> Examine the main contactor Replace the main contactor if necessary See Main contactor replacement, small cabinet or Main contactor replacement, big cabinet Examine the wiring connections <ul style="list-style-type: none"> Examine the CPU PCB Replace the CPU PCB if necessary See CPU PCB (EPS479) replacement
	One or more phases is not present	<ul style="list-style-type: none"> Examine the fuses on power supply PCB Replace the fuses if necessary See Fuses on the power supply PCB (EPS480) replacement <ul style="list-style-type: none"> Examine the external 400 VAC/24VAC transformer Replace the external transformer, if necessary
	One of the fuses for the phases is broken	<ul style="list-style-type: none"> Examine the main fuses Replace the broken fuse. See Main fuses replacement
	The main DC (560V) is too low or not present.	<ul style="list-style-type: none"> Examine the diode bridge Replace the diode bridge PCB if necessary See Diode bridge and sensing PCB (EPS540 / EPS 541) replacement, small cabinet or Diode bridge and sensing PCB (EPS 497) replacement, big cabinet

7.2.3 Fault: Equipment turns ON but suddenly de-energizes

Table 11: Equipment turns ON but suddenly de-energizes

Problem	Possible cause	Solution (See)
After you press the ON button, record these problems: Local mode: <ul style="list-style-type: none"> The display shows an alarm The red lamp on top of the equipment goes on Remote mode: <ul style="list-style-type: none"> The red lamp on top of the equipment goes on 	The input AC line delivers less than 360 VAC	Examine the input VAC line <ul style="list-style-type: none"> Examine the external 400 VAC/24VAC transformer Replace the external transformer, if necessary
	Open circuit	Examine the connection of the high voltage cable to the field connection unit and to the power supply transformer <ul style="list-style-type: none"> Examine the output measure PCB. Replace the output measure PCB, if necessary. See Output measure PCB (EPS442) replacement
	Overcurrent	<ul style="list-style-type: none"> Examine the output measure PCB Replace the output measure PCB, if necessary. See Output measure PCB (EPS442) replacement
	A malfunction of the communication of the output measurement PCB	<ul style="list-style-type: none"> Examine the IGBTs If necessary, replace the IGBT power bridge that contains the IGBT. See IGBT replacement, small cabinet or IGBT replacement, big cabinet
	The current on the primary winding of the power supply transformer is too high	<ul style="list-style-type: none"> Examine the CPU PCB Replace the CPU PCB if necessary See CPU PCB (EPS479) replacement
		<ul style="list-style-type: none"> Examine the IGBT PCB If necessary, replace the IGBT power bridge that contains the IGBT PCB. See IGBT replacement, small cabinet or IGBT replacement, big cabinet

7.2.4 Fault: equipment does not produce requested output current

Table 12: Equipment does not produce the requested output current

Problem	Possible cause	Solution (See)
The red lamp on top of the equipment goes on	The equipment does not operate correctly	<ul style="list-style-type: none"> Examine the IGBT modules If necessary, replace the IGBT power bridge that contains the IGBT module See IGBT replacement, small cabinet or IGBT replacement, big cabinet
		<ul style="list-style-type: none"> Examine the output measure PCB Replace the output measure PCB, if necessary. See Output measure PCB (EPS442) replacement
		<ul style="list-style-type: none"> Examine the IGBT PCB If necessary, replace the IGBT power bridge that contains the IGBT PCB. See IGBT replacement, small cabinet or IGBT replacement, big cabinet

7.3 Checks and measurements

7.3.1 Measure input voltage

1. Make sure that the main switch is **OFF**.
2. Make sure that the input supply cables that come from the mains distribution panel are only connected to the equipment you want to measure.
3. Switch on the mains distribution to feed the equipment you want to measure.
4. Make sure that all connectors are securely tightened.
5. Measure the input voltage (V) to the equipment. Use a True RMS Multimeter.
6. Check the nameplate of the equipment and make sure that the input voltage is compatible with the equipment.

7.3.2 Measure output current

1. Make sure that main switch is **OFF**.
2. Install a calibrated True RMS multimeter with a current clamp in the output circuit.
3. Switch on the equipment and set the equipment to the highest brightness step. See [Select brightness step](#).
4. Read the output current from the True RMS multimeter.
5. Make sure that the measurement is accurate. Calibrate the output current again if necessary.

7.3.3 Check fuse breaker and voltage of switch board

1. Make sure that the main switch is **OFF**.
2. Check the nameplate of the equipment to make sure that the fuse breaker voltage and the current rating of the switchboard is compatible with the equipment. Allowed variance by standards:
 - IEC: +10%
 - FAA: $\pm 10\%$
3. Set the main switch to **ON**.
4. Measure the voltage (V) of the switchboard. Use a calibrated True RMS multimeter.

7.3.4 Calculate minimum insulation resistance of series circuit

1. Calculate the minimum insulation resistance of the series circuit. See [Calculate minimum insulation resistance of series circuit](#).
2. Make sure that the calculated values are higher than the values measured during commissioning.

7.3.5 Calculate resistance of series circuit

1. Calculate the resistance of the series circuit. See [Calculate resistance of series circuit](#).
2. Make sure that the calculated values are higher than the values measured during commissioning.

7.3.6 Measure cable capacitance

Measure the cable capacitance towards the ground as follows:

1. Make sure that the main switch is **OFF**.
2. Connect a multimeter to the regulator output cable. Use a Multimeter that has an internal resistance of 10 MOhm.
3. Disconnect the 500 V DC power cable to the EFD module. The Multimeter now measures the discharge time of the cable capacitance from 400 V DC to 147 V DC.

If the cable capacitance is 1 pF, the measured voltage decreases from 400 V DC to 147 V DC ($=0.37 \times 400$) in approximately 10 seconds.

If the voltage you measure with the LFD module connected is already 330 V DC, the cable leakage resistance is approximately 10 MOhm. In this case, the discharge time is approximately 5 seconds for a cable capacitance of 1 pF.

8.0 Maintenance



WARNING

- Only personnel authorized to work on high-voltage equipment can do maintenance work on the equipment.
- Operate the equipment under local control when you do maintenance work on the equipment to prevent the equipment from being accidentally switched **ON**.
- Follow all local safety procedures.
- Make sure that you have obtained the necessary permissions according to the local operation procedures and procedures regarding HV equipment.

8.1 Preventive maintenance schedule

Table 13: Preventive maintenance schedule

Frequency	Check	Action
In accordance with ICAO Aerodrome Design Manual Part 9 Airport Maintenance practices or in accordance with local maintenance regulations. Adapt the maintenance frequency to the local conditions	Examine the operation of the equipment on all brightness steps on all readings	Use a PC to log the data, if required
	Input voltage	If the input voltage is not within the limits, tell the power company to adjust the voltage. Make sure that you do the necessary actions to align the input voltage with the input limitations
	Output current. Use a calibrated True RMS multimeter and/or a current clamp.	If the output current is not within tolerance, calibrate the output current again
	Visually: <ul style="list-style-type: none"> • that the wiring of the equipment and the circuit is not damaged • for rust spots and general damage • the housing for dust accumulation • all signs on the equipment for legibility and damage 	<ul style="list-style-type: none"> • Repair damaged or loose wires • Replace damaged components • Clean and repair rust spots • Clean the inside of the equipment with a dry air blower
	If the electrical connections (e.g. input connections, output connections) are tightened correctly	Make sure that all connections are tightened

8.2 Part replacement



WARNING

- Make sure you have read and understood all safety procedures and standards related to this equipment. See [Safety](#).
- Make sure you switch **OFF** the power to the equipment. See [Switch OFF the power supply](#).
- Make sure you switch **OFF** the manual switch to remove all power to the equipment.



CAUTION

While you carry out maintenance:

- Do not drop screws or nuts inside the equipment cabinet. Collect loose nuts and screws immediately.
 - To identify all cables you disconnect, label the cables.
 - Make sure that you change the correct PCB.
 - You have saved the equipment settings as a profile. To do this in the configuration software tool, see [Install and operate the configuration software tool](#).
 - Put in the new parts exactly the same way as the parts you removed.
 - After you replace a part, test the equipment to make sure it is replaced correctly.
-



Note

Refer to the electrical schemes inside the equipment cabinet for the connection schemes.

8.2.1 Required tools

Measurement tools

- True RMS Multimeter
-



CAUTION

The output voltage of the 30 kVA / 6.6 A equipment can reach approximately 4600 V at full load. An isolating measurement transformer for use on the 5000 V AC line is recommended.

- Multimeter
 - Insulation tester "Megger" 500 V or 1000 V
 - Clamp or A-meter true RMS scale 10 and 30 A
-



CAUTION

The current regulation is +/- 1%. To make an acceptable readjustment of the output current, the accuracy of the meter must be better than 0.5% for the adjusted value.

Other tools

- Standard electrical and mechanical tool kit
 - Screwdrivers with protection up to 1000 V
 - Spanner set (ring or socket spanners)
 - Allen keys 4 and 6 mm
 - Torque screwdrivers (2 - 10 Nm) and adaptors
 - Short, slotted screwdriver
 - Magnet rod for collecting loose items
 - Angle socket wrench
-

8.2.2 CPU PCB (EPS479) replacement



CAUTION

If you install an OVP version of the CPU PCB, make sure that the diode bridge PCB is also an OVP version.

If you install a non-OVP version of the CPU PCB, make sure that the diode bridge PCB is also a non-OVP version.

Make sure that you update the correct firmware. The firmware code for an OVP version of the PCB ends with an 'e'.

For parts, see [Parts list](#).

- CPU PCB
- Firmware

Remove panel

- Remove the front panel. See [Remove panels](#).

Disconnect

1. Disconnect the connectors and the wires (A).
2. Remove the fasteners (B).
3. Remove the CPU PCB (C).

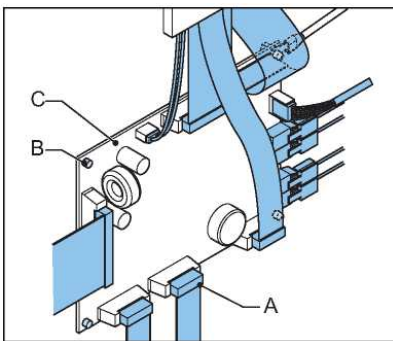

Install

1. Install the new CPU PCB.
2. Install the fasteners.
3. Connect all the wires.



CAUTION

Connect the keyboard cable with the green side down.

Update the firmware

1. Update the firmware. See [Firmware update](#).
2. Install the front panel. See [Remove panels](#).

8.2.3 Diode bridge and sensing PCB (EPS540 / EPS 541) replacement, small cabinet

For parts, see [Parts list](#).

- Diode bridge + sensing PCB



Note

The IGBT PCB, IGBT module, and the diode bridge and sensing PCB together constitute the IGBT power bridge. If one component breaks, replace the entire IGBT power bridge.

Prepare

1. Remove the front panel by way of preparation. See [Remove panels](#).
2. Remove the precharge PCB. See [Precharge PCB \(EPS546\) replacement, small cabinet](#).

Remove

1. Disconnect the wires and connectors (A).
2. Remove the fasteners (B).
3. Remove the diode bridge and sensing PCB (C).

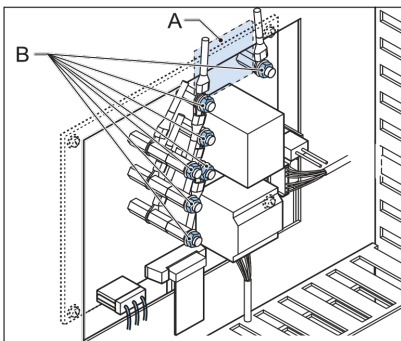
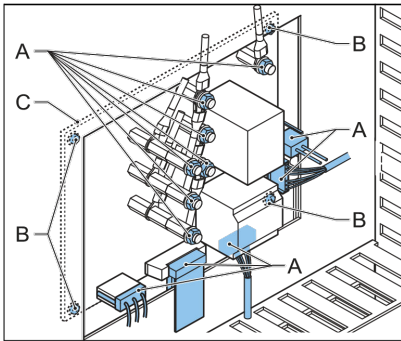

Install

1. Wipe the copper plate (A) clean.
2. Apply an even layer of conductive paste on the copper plate.
3. Install the new diode bridge on the new diode bridge and sensing PCB.
4. Make sure that the diode bridge makes good contact with the heatsink.



CAUTION

If there is a washer or a screw between the diode bridge and the heatsink, the heat dissipation is not sufficient.

5. Connect the wires.



CAUTION

Carefully put the wire (B) through the sensing transformer (C). The sensing transformer is easily damaged.

6. Tighten the fasteners (B). Apply a torque of 2 Nm.
7. Install the precharge PCB. See [Precharge PCB \(EPS546\) replacement, small cabinet](#).
8. Install the front panel. See [Remove panels](#).

8.2.4 Diode bridge and sensing PCB (EPS 497) replacement, big cabinet

For parts, see [Parts list](#).

- Diode bridge + sensing PCB

Prepare

1. Remove the lower front panel. See [Remove panels](#).
2. Remove the precharge PCB. See [Precharge PCB \(EPS546\) replacement, small cabinet](#).



Note

The IGBT PCB, IGBT module, and the diode bridge and sensing PCB together are the IGBT power bridge. If one component breaks, replace the entire IGBT power bridge.

Remove diode bridge

1. Remove the fasteners (A).
2. Disconnect the wires (B).
3. Remove the fasteners (C).
4. Remove the diode bridge (D).

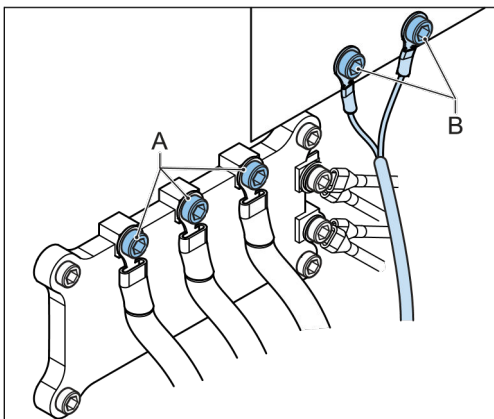
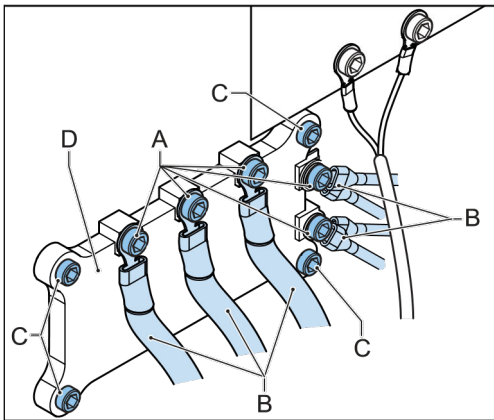

Install - 1

1. Wipe the heat sink clean, where you install the new diode bridge.
2. Apply an even layer of conductive paste on the back side of the new diode bridge.
3. Install the new diode bridge.
4. Make sure that the diode bridge makes good contact with the heatsink.



CAUTION

If there is a washer or a screw between the diode bridge and the heatsink, the heat dissipation is not sufficient.

5. Tighten the fasteners (A). Apply a torque of 4 Nm.
6. Install the new sensing PCB.
7. Connect all the wires to the new diode bridge PCB.
8. Tighten the fasteners (B).

Install - 2

1. Install the precharge PCB. See [Precharge PCB \(EPS456\) replacement, big cabinet](#)
2. Install the lower front panel. See [Generic panels](#).

8.2.5 Display and keyboard replacement

For parts, see [Parts list](#).

- Display/keyboard panel

1. Remove the display/keyboard panel. See [Remove panels](#).
2. Install the new display/keyboard panel. See [Remove panels](#).

8.2.6 Fuses on the power supply PCB (EPS480) replacement

For parts, see [Parts list](#).

- Fuses. See also [Protection devices](#).

1. Remove the lower front panel. See [Remove panels](#).
2. To replace, push, turn counterclockwise and remove the fuse (A). If only one fuse is broken, replace only the broken fuse.
3. Install the new fuse.

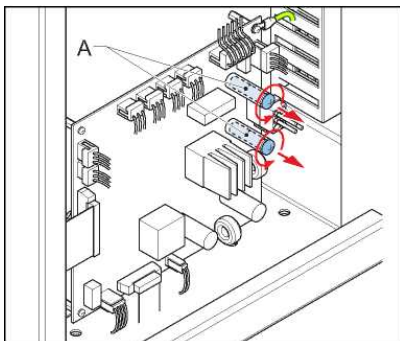

4. Install the lower front panel. See [Remove panels](#).

8.2.7 IGBT PCB (EPS477 / EPS 478) replacement, small cabinet

For parts, see [Parts list](#).

- IGBT PCB
-



Note

The IGBT PCB, IGBT module, and the diode bridge and sensing PCB together are the IGBT power bridge. If one component breaks, replace the entire IGBT power bridge.

The illustrations for this procedure show the situation for the 2.5 kVA and 10 kVA cabinets.

Remove panel

- Remove the front panel. See [Remove panels](#).

Disconnect

1. Make sure that spring number 7 (A) of the IGBT is removed.
Once a spring is removed, it cannot be installed again.
2. Disconnect the connectors and the wires (A).
3. Remove the fasteners (B).
4. Remove the IGBT PCB (C).

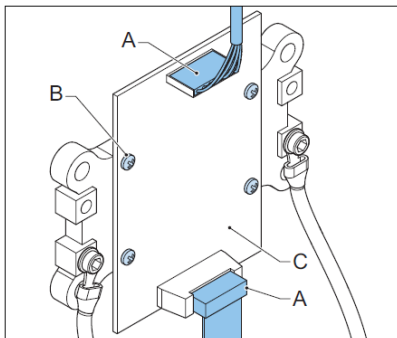

Install



CAUTION

When you tighten the fasteners, only apply force vertically. Use an allen key screwdriver or an allen key handle instead of a socket wrench or a ratchet. Sideways force can cause the components to get damaged.

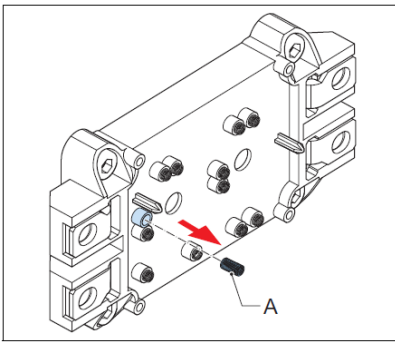

1. Make sure that spring number 7 (A) of the IGBT is removed. Once a spring has been removed, it cannot be reinstalled
2. Install the new IGBT PCB.
3. Connect all the wires.
4. Install the front panel. See [Remove panels](#).

8.2.8 IGBT PCB (EPS496) replacement, big cabinet

For parts, see [Parts list](#).

- IGBT PCB



Note

The IGBT PCB, IGBT module, and the diode bridge and sensing PCB together are the IGBT power bridge. If one component breaks, replace the entire IGBT power bridge.

The procedure shows the IGBT PCB at the right-hand side. The procedure for the IGBT PCB at the left-hand side is similar.

Remove panel

- Remove the lower front panel. See [Remove panels](#).

Remove

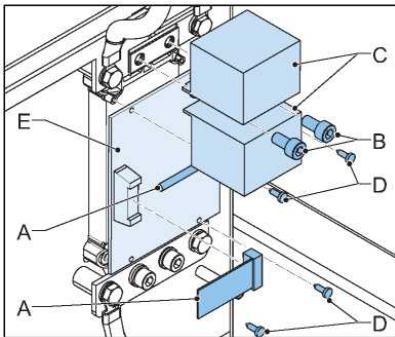

1. Disconnect the wires (A).
2. Remove the fasteners (B).
3. Remove the capacitors (C).
4. Remove the fasteners (D).
5. Remove the IGBT PCB.

Remove the spring from the IGBT

- Make sure that spring number 7 (A) of the IGBT is removed. Once a spring has been removed, it cannot be reinstalled.

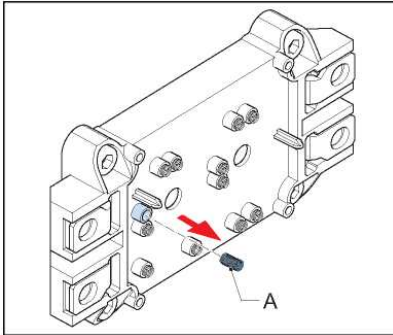

Install



CAUTION

When you tighten the fasteners, only apply force vertically. Use an alien key screwdriver or an allen key handle instead of a socket wrench or a ratchet. Sideways force can cause the components to get damaged.

1. Install the new IGBT PCB (A) on the IGBT.
2. Install the fasteners (B) crosswise. Apply a torque of 4 Nm.
3. Install the capacitors (C).
4. Install the fasteners (D). Apply a torque of 4 Nm.
5. Connect the wires (E).

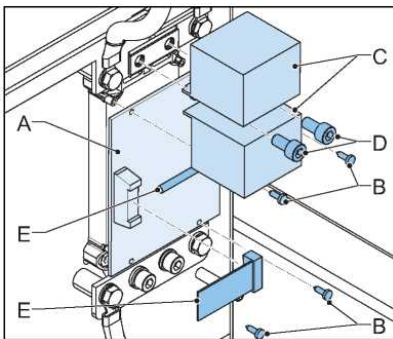

8.2.9 IGBT replacement, small cabinet

For parts, see [Parts list](#).

- IGBT



Note

The IGBT PCB, IGBT module, and the diode bridge and sensing PCB together are the IGBT power bridge. If one component breaks, replace the entire IGBT power bridge.

The illustrations for this procedure show the situation for the 2.5 kVA and 10 kVA cabinets.

Remove panel

- Remove the front panel. See [Remove panels](#).

Remove 1

1. Remove the fasteners (A).
2. Remove the capacitor plate (B).
3. Remove the IGBT PCB. See [IGBT PCB \(EPS477 / EPS 478\) replacement, small cabinet](#).

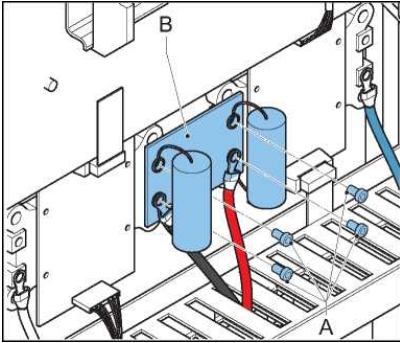

Remove 2

1. Disconnect the wire (A).
2. Remove the fasteners (B).
3. Remove the IGBT (C).

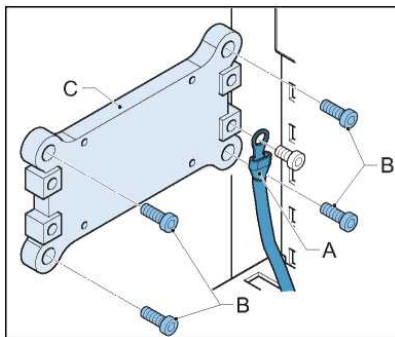

Install 1

1. Wipe clean the heat sink below the IGBT (A).
2. Apply an even layer of conductive paste on the rear of the IGBT (the side that touches the heat sink).
3. Tighten the fasteners (B) crosswise. Apply a torque of 4 Nm.

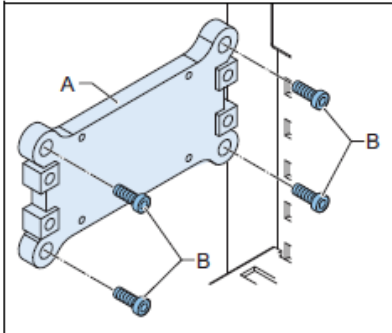

Install 2

1. Install the IGBT PCB. See [IGBT PCB \(EPS477 / EPS 478\) replacement, small cabinet](#).
2. Install the capacitor plate.
3. Connect the wires.
4. Install the fasteners (A). Apply a torque of 4 Nm.
5. Install the front panel. See [Remove panels](#).

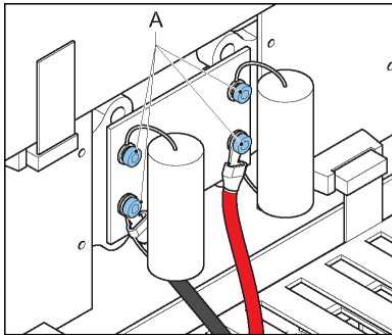

8.2.10 IGBT replacement, big cabinet

i Note

The IGBT PCB, IGBT and the diode bridge and sensing PCB together are the IGBT power bridge. If one component breaks, replace the entire IGBT power bridge.

1. Remove the IGBT PCB. See [IGBT PCB \(EPS496\) replacement, big cabinet](#).
2. With a new IGBT, install the IGBT PCB. See [IGBT PCB \(EPS496\) replacement, big cabinet](#).

8.2.11 Lightning arrestors replacement, equipment with SCO or SCB

For parts, see [Parts list](#).

- Lightning arrestors

i Note

The number of lightning arrestors can be different from the illustrations, depending on the output power.

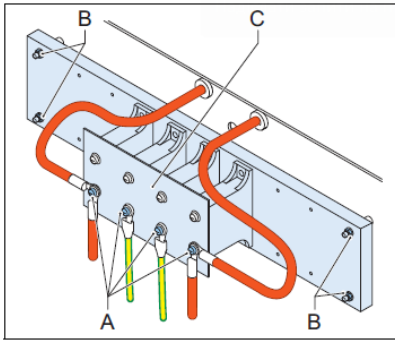

1. Remove the side panels. See [Remove panels](#).
2. Disconnect the wires (A).
3. Remove the fasteners (B).
4. Remove the lightning arrestors assembly (C).
5. Install the new lightning arrestors assembly.
6. Install the wires.
7. Install the side panels. See [Remove panels](#).

8.2.12 Line filter replacement

For parts, see [Parts list](#).

- Line filter

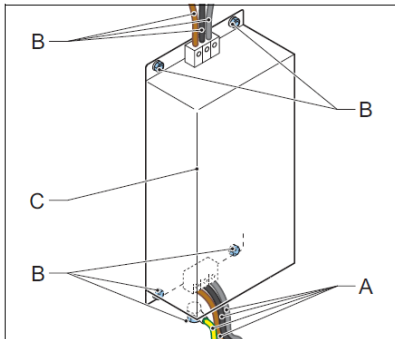

1. Remove the side panels. See [Remove panels](#).
2. Remove the lower rear panel. See [Remove panels](#).
3. Disconnect the wires (A).
4. Remove the fasteners (B).
5. Remove the line filter (C).
6. Install the new line filter.
7. Install the wires.
8. Install the lower rear panel. See [Remove panels](#).
9. Install the side panels. See [Remove panels](#).

8.2.13 Main contactor replacement

For parts, see [Remove panels](#).

- Main contactor



WARNING

Make sure that you switched OFF the power to the equipment. See [Switch OFF the power supply](#).



WARNING

Make sure that you switched OFF the external disconnection device to remove all power to the equipment.

Remove panel

- Remove the lower front panel. See [Remove panels](#).

:

Disconnect

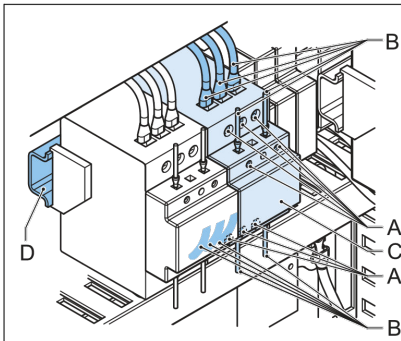

1. Loosen the screws (A).
2. Disconnect the wires (B).
3. Remove the main contactor (C). Use a screwdriver as a lever to release the manual switch from the rail (D).

Install

1. Install the new main contactor.
2. Connect all the wires.
3. Tighten the screws (A). Apply a torque of 4 (big cabinet) or 5 (small cabinet) Nm.

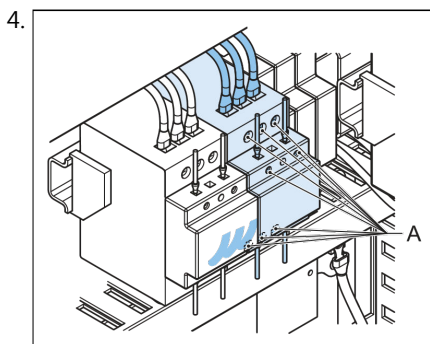

Install the lower front panel. See [Remove panels](#).

8.2.14 Main fuses replacement

For parts, see [Parts list](#).

- Fuses. See also [Protection devices](#).
1. Remove the lower front panel. See [Remove panels](#).
 2. Open the fuse holder (A).
 3. Replace the fuse (B).
 4. Close the fuse holder.
 5. Install the lower front panel. See [Remove panels](#).

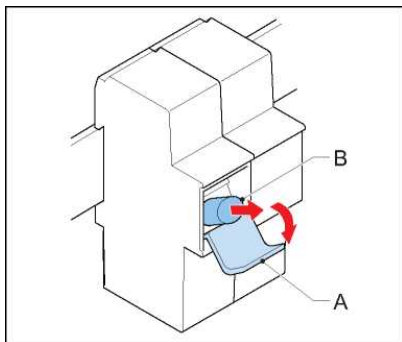

8.2.15 Manual switch replacement

For parts, see [Remove panels](#).

- Manual switch



WARNING

Make sure you switch **OFF** the power to the equipment. See [Switch OFF the power supply](#).



Note

Make sure you switch **OFF** the external disconnection device to remove all power to the equipment.

Remove panel

- Remove the lower front panel. See [Remove panels](#).

Disconnect

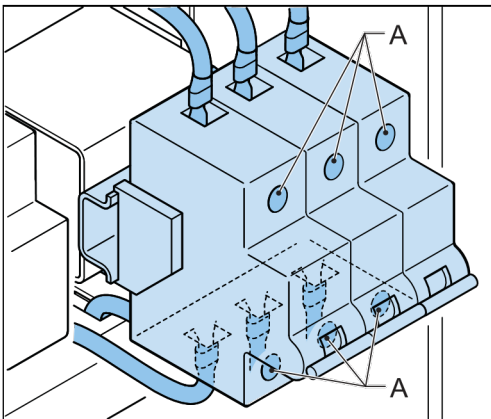
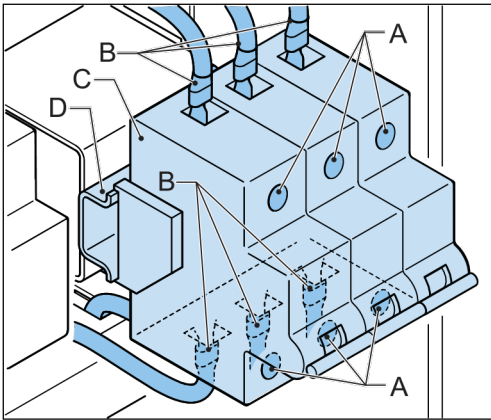

1. Loosen the screws (A).
2. Disconnect the wires (B).
3. Remove the manual switch (C). Use a screwdriver as a lever to release the manual switch from the rail (D).

Install

1. Install the new manual switch.
2. Connect all the wires.
3. Tighten the screws (A). Apply a torque of 4 Nm.
4. Install the lower front panel. See [Remove panels](#).

8.2.16 Output filter replacement, small cabinet

For parts, see [Remove panels](#).

- Input filter
- Output filter



Note

- The number of filters and capacities can be different from the illustrations, depending on the output power.
- Always replace the input filter and the output filter together.
- For equipments up to 7.5 kVA, the output filter is not installed on a plate, but directly on the housing. In this case, replace all individual filter parts.

Remove panel

- Remove the side panels. See [Remove panels](#).

:

Remove

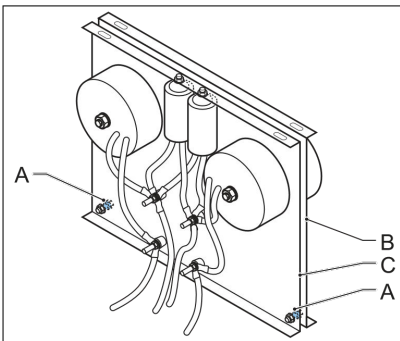
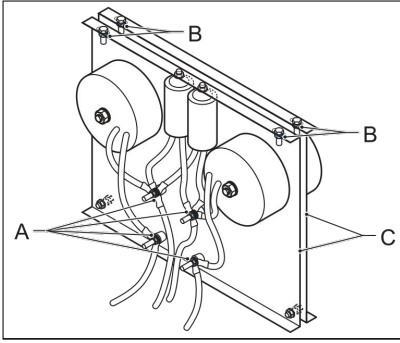

1. Disconnect the wires (A).
2. Remove the fasteners (B).
3. Remove the output filter plate (C).

Disconnect

1. Disconnect the fasteners (A).
2. Remove the output filter plate (C) from the back plate (B).

Install

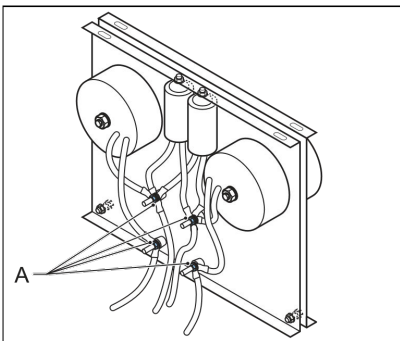

1. Install the new output filter plate.
2. Connect the wires.
3. Tighten the fasteners (A). Apply a torque of 6 Nm.
4. Install the side panels. See [Remove panels](#).

8.2.17 Output filter replacement, big cabinet

For parts, see [Remove panels](#).

- Input filter
- Output filter



Note

- The number of filters and capacities can be different from the illustrations, depending on the output power.
- Always replace the input filter and the output filter together.

Remove panel

- Remove the side panels. See [Remove panels](#).

Remove

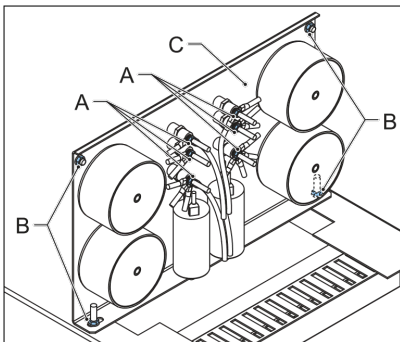

1. Disconnect the wires (A).
2. Remove the fasteners (B).
3. Remove the output filter plate (C).

Install

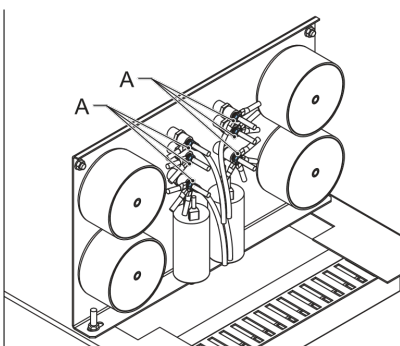

1. Install the new output filter plate.
2. Install the wires.
3. Tighten the fasteners (A). Apply a torque of 6 Nm.
4. Install the side panels. See [Remove panels](#).

8.2.18 Output measure PCB (EPS442) replacement

Parts: see [Parts list](#).

- Output measure PCB

Remove panels

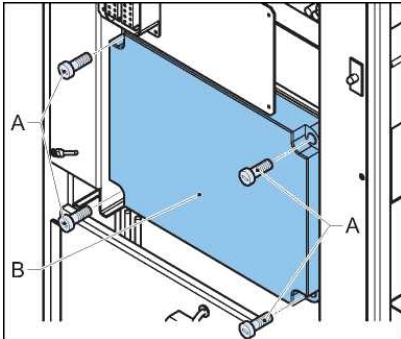

1. Remove the upper rear panel. See [Remove panels](#).
2. Remove the screws (A).
3. Remove the box panel (B).

Disconnect

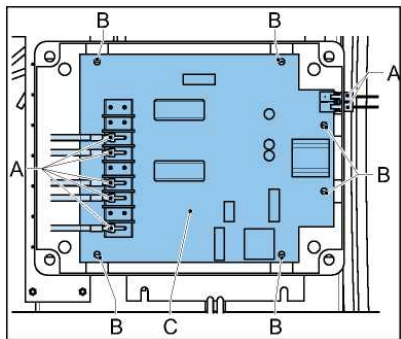

1. Disconnect the wires and connectors (A).
2. Remove the fasteners (B).
3. Remove the output measure PCB (C).

Install

1. Install the new output measure PCB.
2. Install the wires and connectors.
3. Install the box panel.
4. Install the upper rear panel. See [Remove panels](#).

8.2.19 Power supply PCB (EPS480) replacement

For parts, see [Parts list](#).

- Power supply PCB

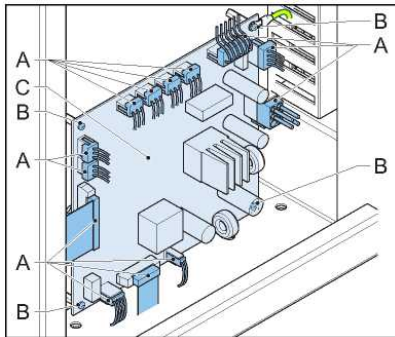

1. Remove the front panel. See [Remove panels](#).
2. Disconnect the connectors and the wires (A).
3. Remove the fasteners (B).
4. Remove the power supply PCB (C).
5. Install the new power supply PCB.
6. Connect all the wires.
7. Install the front panel. See [Remove panels](#).

8.2.20 Precharge contactor replacement

For parts, see [Remove panels](#).

- Precharge contactor



WARNING

Make sure you have switched **OFF** power to the equipment. See [Switch OFF the power supply](#).

Remove panel

- Remove the lower front panel. See [Remove panels](#).

Disconnect

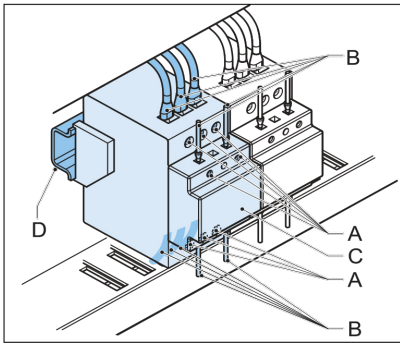

1. Loosen the screws (A).
2. Disconnect the wires (B).
3. Remove the precharge contactor (C). Use a screwdriver as a lever to release the manual switch from the rail (D).

Install

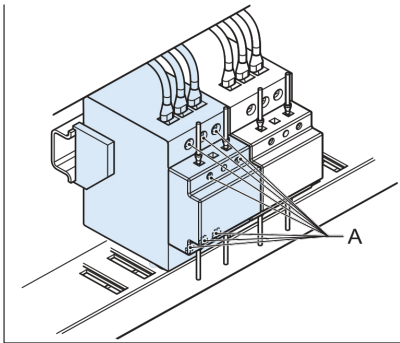

1. Install the new precharge contactor.
2. Connect all the wires.
3. Tighten the screws (A). Apply a torque of 4 (big cabinet) or 5 (small cabinet) Nm.
4. Install the lower front panel. See [Remove panels](#).

8.2.21 Precharge PCB (EPS546) replacement, small cabinet

For parts, see [Remove panels](#).

- Precharge PCB

Remove panel

- Remove the lower front panel. See [Remove panels](#).

Disconnect

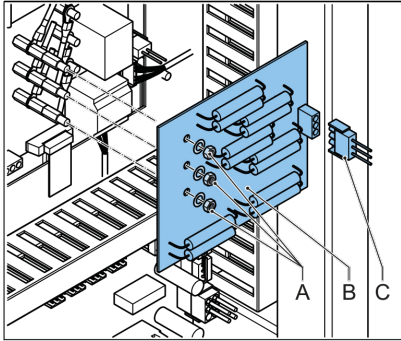

1. Remove the fasteners (A).
2. Remove the precharge PCB (B).
3. Disconnect the connectors (C).

Install

1. Connect the connector.
2. Install the new precharge PCB.
3. Tighten the fasteners with a torque of 2 Nm. Install the front panel. See [Remove panels](#).

8.2.22 Precharge PCB (EPS456) replacement, big cabinet

Remove panel

- Remove the lower front panel. See [Generic panels](#).

Remove

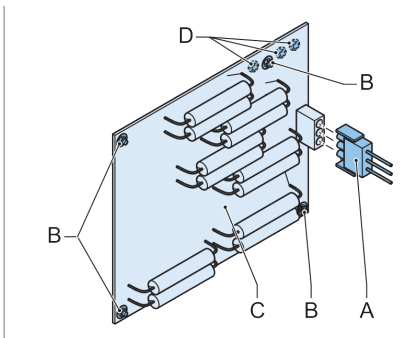

1. Disconnect the connector (A).
2. Remove the fasteners (B).
3. Carefully remove the precharge PCB (C).

4. Remove the fasteners (D).
5. Remove the electrical wires.

Install

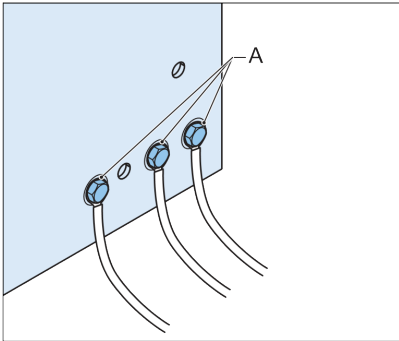

1. Connect all the wires.
2. Tighten the fasteners (A). Apply a torque of 4 Nm.
3. Install the new precharge PCB.
4. Install the lower front panel. See [Generic panels](#).

8.2.23 Remote control PCB (EPS495 or EP00051) replacement

For parts, see [Parts list](#).

- Remote control PCB or remote control PCB SIN

Note

The procedure is similar for the replacement of the remote control PCB SIN.

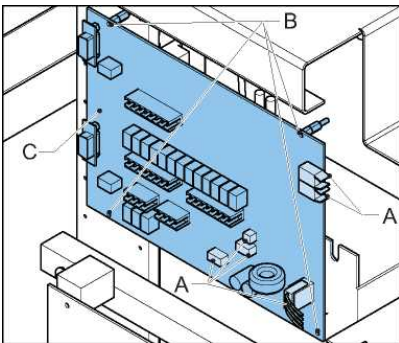

1. Remove the upper rear panel. See [Remove panels](#).
2. Disconnect the connectors and the wires (A).
3. Remove the fasteners (B).
4. Remove the remote control PCB (C).
5. [Only applicable to EPS495.] Set the dip-switches of the new remote control PCB. See [Remote Control PCB](#).
6. Install the new remote control PCB.
7. Connect all the wires.



CAUTION

Depending on the configuration of the equipment, other wires need to be connected. These can be different from the illustration above.

8. Install the upper rear panel. See [Remove panels](#).

8.2.24 Series Connection Box (SCB) replacement (option)

For parts, see [Parts list](#).

- Series Connection Box (SCB)

Prepare

1. Switch **OFF** the power supply. See [Switch OFF the power supply](#).
2. Make sure that the circuit is earthed.

Remove panel

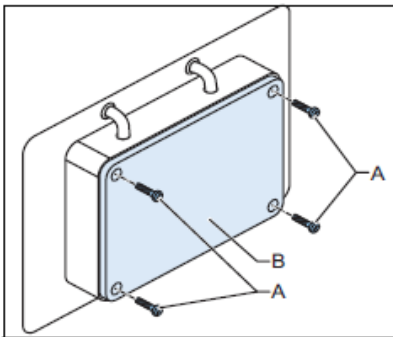

1. Loosen the fasteners (A).
2. Remove the box panel (B).

Remove

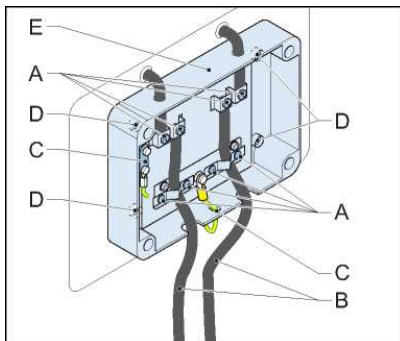

1. Loosen the screws (A).
2. Disconnect the series circuit cables (B).
3. Disconnect the wires and connectors (C).
4. Loosen the screws (D).
5. Carefully remove the SCB (E).

Install

1. Install the new SCB.
2. Put the series circuit cables through the stress-relief clamps.
3. Tighten the screws of the stress-relief clamps.
4. Install all the wires and connectors.
5. Install the box panel.

8.2.25 Series CutOut (SCO) replacement (option)

For parts, see [Parts list](#).

- Series CutOut (SCO)

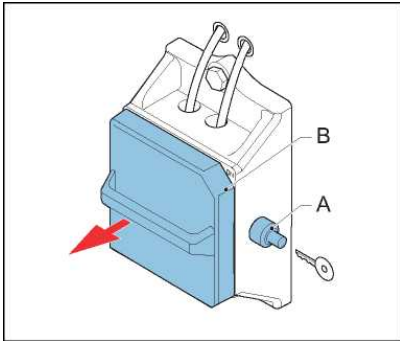

Prepare

1. Switch Off the power supply. See [Switch OFF the power supply](#).
2. Make sure that the circuit is earthed.
3. Open the lock (A).
4. Remove the cover (B). Use the handle.

Remove

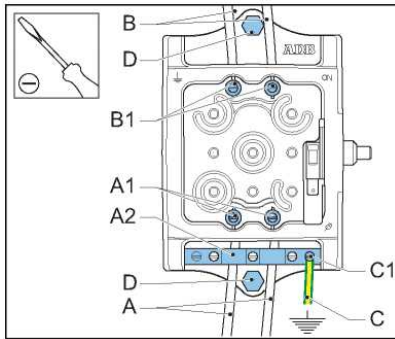

1. Loosen the screws (A1).
2. Remove the series circuit cables from the earthing bar (A2).
3. Disconnect the series circuit cables (A).
4. Loosen the screws (B1).
5. Disconnect the output cables (B).
6. Loosen the screw (C1)
7. Disconnect the earthing wire (C).
8. Remove the bolts (D).
9. Remove the SCO.

Connect the micro switch

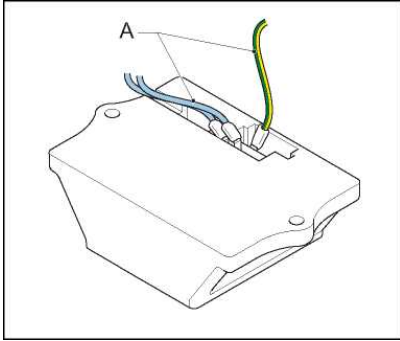

1. Disconnect the cables to the micro switch (A).
2. Connect the cables to the micro switch (A) in the new SCO.

Install

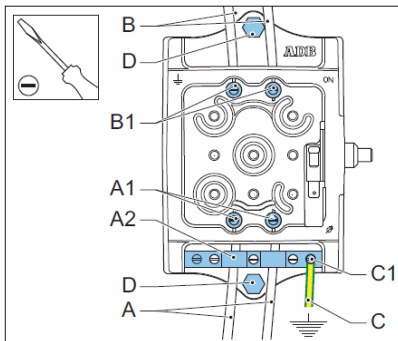

1. Install the new SCO.
2. Install the bolts (D).
3. Connect the earthing wire (C). Use the screw connection (C1).
4. Connect the output cables (B).
5. Tighten the screws B1.
6. Connect the series circuit cables (A).
7. Tighten the screws (A1).
8. Connect the wires to the earthing bar (A2).
 - Make the connection of the shield of the cable to the earthing bar.
 - If there is no shield on the cable, connect a clamp to the outside of the cable.

Finish

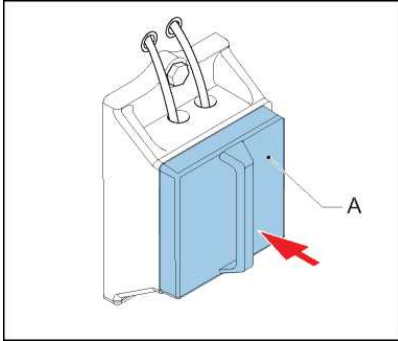

- Install the cover of the SCO (A).

8.3 Remove panels

The panels of the equipment can be removed for installation or maintenance procedures.



WARNING

- Do not operate the equipment with any of the panels removed
- Do not mix panels from different equipment
- Always connect the earthing wires before you install the panels
- The panels can be heavy, especially the side panels
- Do not change or lock the panel switches. A panel switch sees if a panel is installed or not.



Note

The panels differ in size and number of screws. The illustrations below show the principle.

8.3.1 Remove the display / keyboard panel of the small cabinet

Disconnect HMI

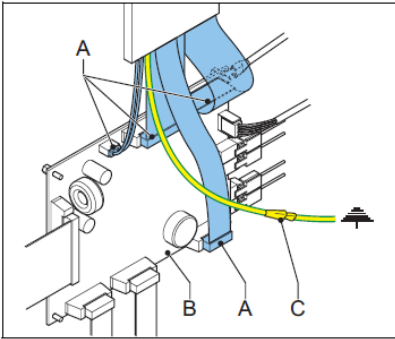

1. Remove the front panel. See [Generic panels](#).
2. Disconnect the wires (A) to the HMI from the CPU PCB (B).
3. Disconnect the earthing wire (C).

Remove panel

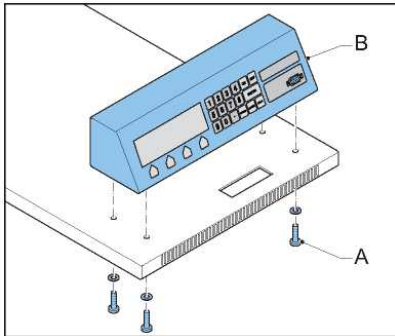

1. Remove the top panel. See [Top panel \(small cabinet\)](#) .
2. Remove the screws (A).
3. Carefully remove the panel (B).



CAUTION

Take care not to damage cables and connectors.

8.3.2 Remove the display / keyboard panel of the big cabinet

Disconnect HMI

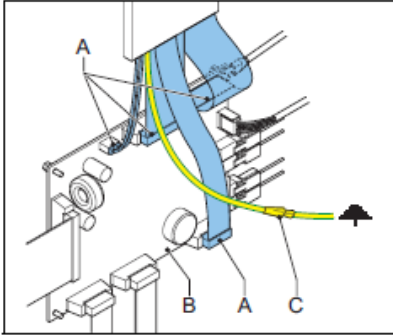

1. Remove the lower front panel. See [Top panel \(small cabinet\)](#).
2. Disconnect the wires (A) to the HMI from the CPU PCB (B).
3. Disconnect the earthing wire (C).

Remove panel

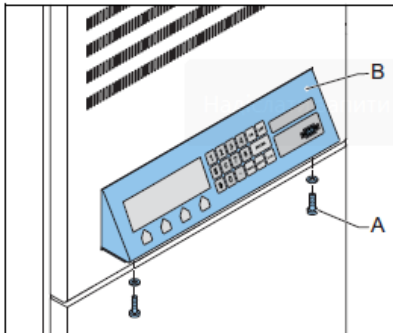

1. Remove the screws (A).
2. Carefully remove the panel (B).



CAUTION

Take care not to damage cables and connectors.

8.3.3 Top panel (small cabinet)

Disconnect HMI

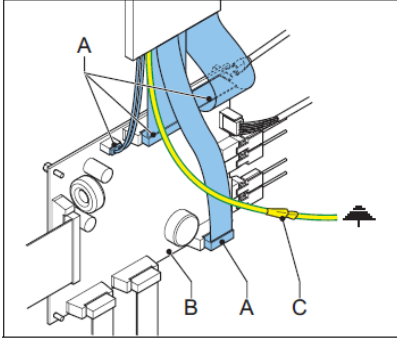

1. Remove the front panel. See [Generic panels](#) .
2. Disconnect the wires (A) to the HMI from the CPU PCB (B).
3. Disconnect the earthing wire (C).

Remove

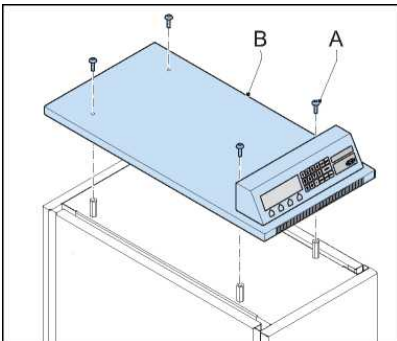

1. Remove the screws (A).
2. Remove the top panel (B).

Disconnect wires

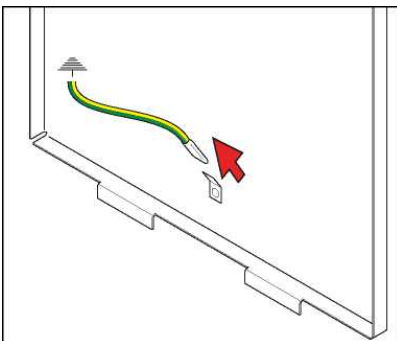

- Disconnect the green/yellow earthing wires. The wires have a fast-on connector.

8.3.4 Generic panels

Remove panel

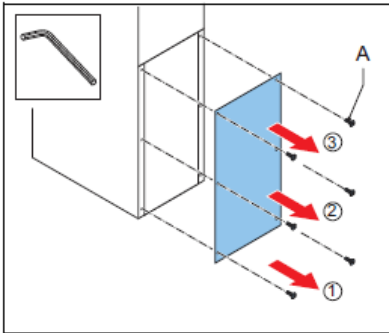

1. Set the manual switch to the **Off** position.
2. Remove the screws (A) from the bottom to the top.



WARNING

The panels are heavy. Also, the momentum of the panel can cause damage to the panel and the screws if you remove the top screws first.

3. Carefully remove the panel (B).



CAUTION

Take care to not damage cables and connectors.

Disconnect wires

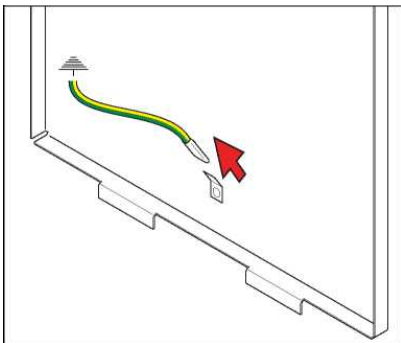

- Disconnect the green/yellow earthing wires. The wires have a fast-on connector.

8.4 Firmware update

Tools

- PC with serial port connection
- Firmware update dongle: 'Pin to Pin DB9P & DB9S cable'
- Correct firmware upload file

Firmware update procedure

1. Install the software to upload the firmware. See [Install the software to upload the firmware](#).
2. Change the SD flash file paths, if necessary. See [Change the SD Flash file paths](#).

3. Do a check on the equipment parameters. See [Check equipment parameters](#).
4. Update the firmware. See [Update the firmware](#).
5. Start the equipment after a firmware update. See [Start the equipment after a firmware update](#).

8.4.1 Install the software to upload the firmware

Install the software

1. Unzip the file 'sdflash.zip' to the default path of D:\sdflash.



Note

If you extract the zip file to a different location, see [Change the SD Flash file paths](#).

2. Run the program SDFlash.exe.
3. Select **File > Open Project**.
4. Select the 'F2812SerialFlash.sdp' project from the 'sdflash' directory.
5. If you opened the program for the first time, select the correct Emulator Address/ID.



Note

This is the same process as selecting the correct COM-port address, where C4 would equal COM 4. Refer to the device manager of the PC to find the correct address. You can change this setting later from the Project >Settings >Target tab>Emulator Address/ID drop down list.

6. Go to **File > Exit**.
7. Click **Save**.

Check the port settings

1. Go to **Start>Control Panel>System>Hardware tab>Device Manager>Ports>USB Serial Port**.
2. Right-click on **USB Serial Port**.
3. Select **Properties**.
4. Select the tab **Port Settings**.
5. In the **Advanced Settings for COM** window, do as follows:
 - Make sure that the COM Port Number is correct. Select the correct Emulator Address/ID (see earlier in this procedure)
 - Change Receive (Bytes) to 4096
 - Change Transmit (Bytes) to 4096
 - Change Latency Timer (msec) to 16

8.4.2 Change the SD Flash file paths



Note

Follow this procedure if you extracted the zip file 'sdflash.zip' to a different location than D:\sdflash.

1. Go to **Project > Settings**.
2. In the indicated tabs, change the indicated fields to the correct file path.

Tab	Field
Target	Driver
	Board File
Erase	Algorithm
Programming	Algorithm
Verify	Algorithm

3. Click **OK**.

8.4.3 Check equipment parameters

1. Start the configuration software tool. See [Start the configuration software tool](#).
2. Go to the **Configuration** screen.
3. Go to the **Identification** tab.
4. Push the **Read** button to show the firmware details.
5. Make sure that the equipment parameters below match those of the filename of the required firmware version:
 - Single Phase (CRE) or Tri-phase (VIS)
 - Input Voltage: 230V range or 400V range
 - CCR Power Rating in kVA
 - SHVS installed or SHVS not installed.
 - The type of control system. This is PPT unless specified.
6. Stop the configuration software tool. See [Stop the configuration software tool](#).
7. Switch **OFF** the equipment. See [Switch OFF the equipment](#).
8. Make sure that the manual switch is in the **OFF** position. See [Switch OFF the power supply](#).

8.4.4 Update the firmware

Prepare the equipment

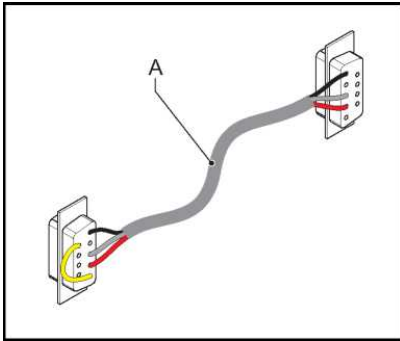

1. Remove the lower front panel. See [Generic panels](#)
2. Remove the watch-dog jumper from the CPU PCB (EPS479). See [CPU PCB \(EPS479\)](#).
3. Connect the firmware update dongle (A) between the PC and the equipment.
4. Click on SDFlash.exe.
5. Do a check if F2812SerialFlash.sdp loads.
6. If not, see [Install the software to upload the firmware](#) and load the correct project.
7. Switch ON the equipment. See [Operation](#). When the equipment is ready for the firmware upload, the HMI is blank.
8. If the HMI is not blank, see [Install the software to upload the firmware](#) and load the correct project.

Upload the firmware

1. Go to **Project>Settings>Programming tab>Flash Data File field**.
2. Select the correct firmware version file from the files with a *.out extension.
3. Go to **Device>Flash**. If asked to save changes, click **yes**.
4. Make sure that the **Erase, Program and Verify** check boxes are checked.
5. Click **Start**.
6. Wait until the upload is complete.
7. Close the SDFlash program.

8.4.5 Start the equipment after a firmware update

Start the equipment again

1. Switch **OFF** the equipment. See [Switch OFF the equipment](#).
2. Make sure that the manual switch is in the **OFF** position. See [Switch OFF the power supply](#).
3. Install the watch-dog jumper on the CPU PCB.
4. Switch **ON** the equipment. See [Operation](#).

Check if the firmware is correctly updated

1. Make sure that the firmware data on the lower line of the main menu on the HMI is correct.
2. Start the configuration software tool. See [Start the configuration software tool](#).
3. Go to the **Configuration** screen.
4. Go to the **Identification** tab.
5. Push the **Read** button to show the firmware details.

Disconnect the cable and install the front panel

1. Switch **OFF** the equipment. See [Switch OFF the equipment](#).
2. Make sure that the manual switch is in the **OFF** position. See [Switch OFF the power supply](#).
3. Disconnect the firmware update dongle.
4. Install the lower front panel. See [Generic panels](#).
5. Switch **ON** the equipment. See [Operation](#).

9.0 PCB drawings and settings

9.1 CPU PCB (EPS479)

Figure 28: Printed Circuit Board (PCB)

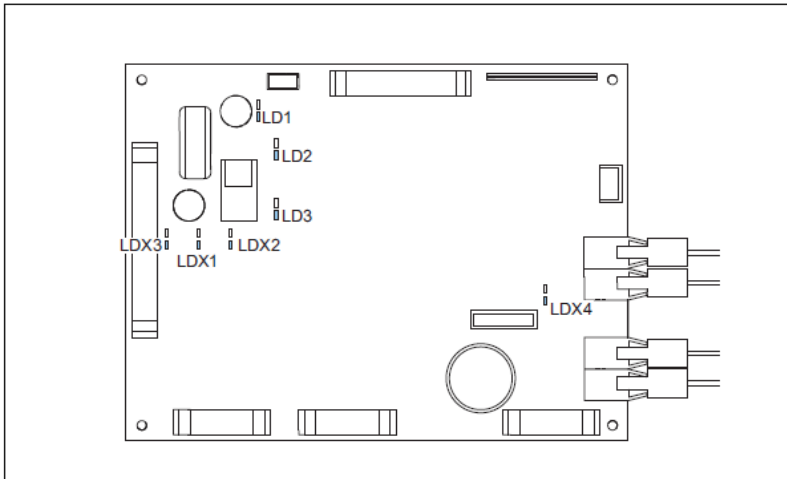

9.1.1 LEDs

Table 14: CPU PCB LED functions

LED	Color	Function
LDX1	Red	The voltage for the power supply is +5V DC (generated on the PCB)
LDX2	Red	The voltage is +5V DC
LDX3	Red	The voltage from the power supply PCB is +12 V DC
LDX4	Red	The CPU operates
LD1	Green	The voltage for the power supply on the PCB is +5 V DC (generated on the PCB)
LD2	Green	The voltage for the power supply on the PCB is +3.3 V DC (generated on the PCB)
LD3	Green	The voltage for the powers supply on the PCB is +1.8 V DC (generated on the PCB)

9.2 Power supply PCB (EPS480)

Figure 29: Printed Circuit Board (PCB)

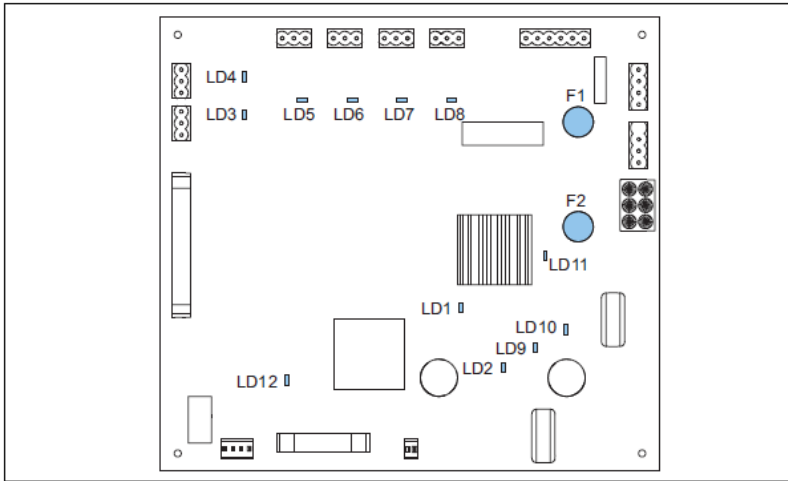

9.2.1 LEDs

Table 15: Power supply PCB LED functions

LED	Color	Function
LD1	Green	The voltage for the fans, if applicable is +24 V DC (generated on the PCB)
LD2	Red	The voltage of the power supply on the PCB is 12 V DC
LD3	Red	The fan connected to J8 is active
LD4	Red	The fan connected to J10 is active
LD5	Red	The LED is red when the fan connected to J12 is active
LD6	Red	The fan connected to J14 is active
LD7	Red	The fan connected to J16 is active
LD8	Red	The fan connected to J18 is active
LD9	Red	The the input voltage after the diode bridge PT is 24 V DC (nominal)
LD10	Red	The voltage of the power supply on the PCB is 20 V DC
LD11	Red	The sense input line voltage is 24 V AC (nominal)
LD12	Green	The voltage from the 50 kHz power supply on the PCB is 48 V DC

9.2.2 Fuses

Table 16: Power supply PCB Fuses

F1	1.6 A
F2	2.5 A

9.3 Remote Control PCB



Note

Until 2022, the VIS was delivered with the EPS495 board as the remote control PCB. Since 2022, the VIS has been delivered with the EP00047, and the EP00051 as an add-on board when Multiwire is required. The functionalities of these boards are equivalent in most cases, with the exception of the most demanding recent ALCMS systems with a redundant bus. For VIS units equipped with the EPS495, there are options to transition to the EP00047 (and the EP00051 add-on if needed) when required. Please contact your ADB Safegate representative for more details if needed.

9.3.1 EPS495 (1597.00.300)

Figure 30: Printed Circuit Board (PCB)

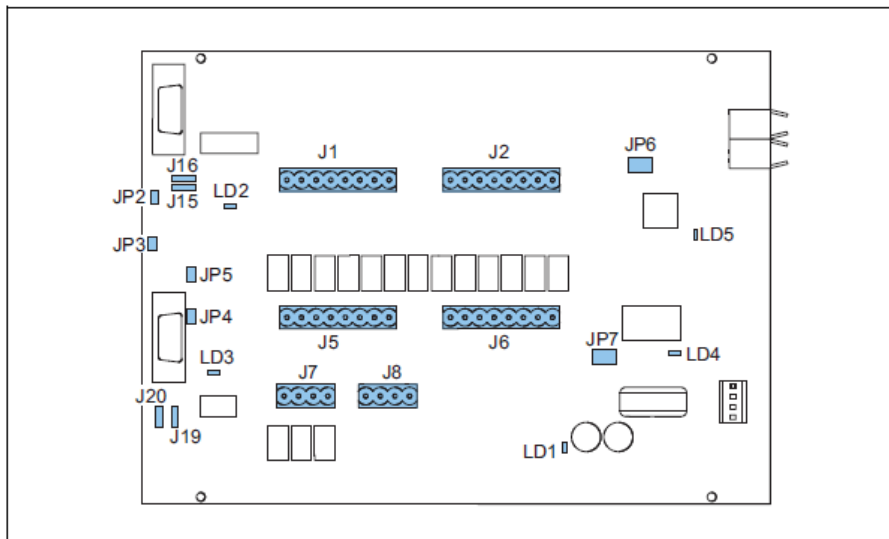

9.3.1.1 LEDs

Table 17: Remote control PCB LED functions

LED	Color	Function
LD1	Green	The LED is green when the voltage of the power supply on the PCB is 12 V DC
LD2	Green	The LED is green when the voltage from the DCDC1, generated on the PCB, is + 5 V DC insulated
LD3	Green	The LED is green when the voltage from the DCDC2, generated on the PCB, is + 5 V DC insulated
LD4	Red	The LED flashes red when the U5 CPU is active
ID5	Red	The LED flashes red when the U6 CPU is active

9.3.1.2 Jumper settings

Table 18: Remote control PCB jumper settings

Jumper	Position	Function
JP2	insert	enable TX serial channel 1 termination resistance
JP3	insert	enable RX serial channel 1 termination resistance
JP4	insert	enable TX serial channel 2 termination resistance
JP5	insert	enable RX serial channel 2 termination resistance

Table 18: Remote control PCB jumper settings (Continued)

Jumper	Position	Function
JP6	position 1-3 and position 2-4 1 3 5 2 4 6	ethernet channel 1: enable
	position 3-5 and position 4-6 1 3 5 2 4 6	serial channel 1: enable
JP7	position 1-3 and position 2-4 1 3 5 2 4 6	ethernet channel 2: enable
	position 3-5 and position 4-6 1 3 5 2 4 6	serial channel 2: enable
J15	position 2-3 3 2 1	serial channel 1: RS485 configuration
	position 1-2 3 2 1	serial channel 1: RS422 configuration (not used)
Jumper	Position	Function
J16	position 2-3 1 2 3	serial channel 1: RS485 configuration
	position 1-2 1 2 3	serial channel 1: RS422 configuration (not used)
J19	position 2-3 1 2 3	serial channel 2: RS485 configuration
	position 1-2 1 2 3	serial channel 2: RS422 configuration (not used)
J20	position 2-3 1 2 3	serial channel 2: RS485 configuration
	position 1-2 1 2 3	serial channel 2: RS422 configuration (not used)

9.3.2 EP00047 and EP00051

Figure 31: Printed Circuit Board (PCB)

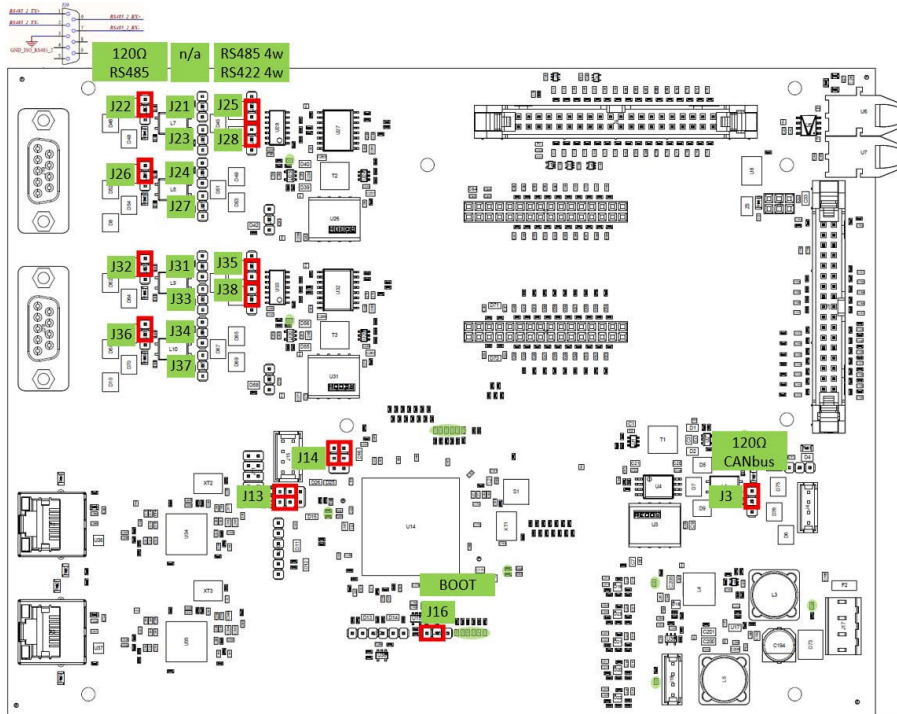

Bus A		Bus B		CAN		μProc	
J22	120 Ohm RS485_2_TX+ (1-2)	J32	120 Ohm RS485_1_TX+	J3	120 Ohm CAN (1-2)	J16	Boot-GND (2-3)
J26	120 Ohm RS485_2_RX+	J36	120 Ohm RS485_1_RX+				
J25	RS485_2_RX+ (4w:2-3, 2w:1-2)	J35	RS485_1_RX+ (4w:2-3)				
J28	RS485_2_RX- (4w:2-3)	J38	RS485_1_RX- (4w:2-3)				
J14	RS485_2 (3-5, 4-6)	J13	RS485_1 (3-5, 4-6)				

9.3.3 Multiwire/J-Bus connection scheme

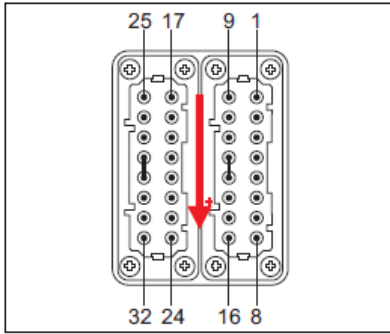

Note

The table shows the standard remote control configuration for the signals. If you want another configuration, contact ADB Safegate.

Table 19: Factory set terminal assignments for remote control connections with multiwire and single J-Bus (Cable Set 4072.30.XXX)

Function	Terminal number on 32-pole connector	Relay number on Remote Control PCB (unless indicated otherwise)
Control signals (fixed)		
Step 1 - CMD	1	J1.1
Step 2 - CMD	2	J1.2
Step 3 - CMD	3	J1.3
Step 4 - CMD	4	J1.4
Step 5 - CMD	5	J1.5
ON - CMD	6	J1.6
CCR OFF from HVCS - CMD	26	J1.7
NC	NC	J1.8
V-OUT 48V	15	J8.1
GND 48V	17	J8.2
CM – FB (general common relay return)	8	J8.3
CM – FB (general common relay return)	7, 18, J6.4	J8.4
	24	CRE doormswitch (power input door)
	26	CRE doormswitch (power input door)
	7	
Feedback signals (fixed)		
Step 1	9	J5.1
Step 2	10	J5.2
Step 3	11	J5.3
Step 4	12	J5.4
Step 5	13	J5.5
ON (step1,2...5) / OFF (OFF or Standby Step0)	19	J5.6

Table 19: Factory set terminal assignments for remote control connections with multiwire and single J-Bus (Cable Set 4072.30.XXX) (Continued)

Function	Terminal number on 32-pole connector	Relay number on Remote Control PCB (unless indicated otherwise)
Feedback signals (configurable via HMI): the values below are default values, for configuration options (for the options, see the table that follows)		
Disable local/remote (relay 7 for both connections)	14	J5.7 (NC relay)
	28	J5.8 (NO relay)
Open circuit - FB	16	J6.1
Overcurrent - FB	20	J6.2
Bad regulation	22	J6.3
	7, 18, J8.4	J6.4 (CM)
LFD alarm (Relay 11)	23	J6.5 (NO relay)
NC	NC	J6.6
EFD warning - FB	24	J6.7
EFD error - FB	25	J6.8
High temperature alarm - FB	27	J7.1
Short circuit - FB	29	J7.2
Lamp fault warning - FB (not used)	21	J7.3
	NC	J7.4
J-Bus interface (fixed)		
RS485 Bus A GND	30	DB9.3
RS485 Bus A +	31	DB9.1
RS485 Bus A -	32	DB9.2

Table 20: Factory set terminal assignments for remote control connections with multiwire dual J-Bus (Cable Set 4072.30.182)

Function	Terminal number on 32-pole connector	Relay number on Remote Control PCB (unless indicated otherwise)
Control signals (fixed)		
Step 1 - CMD	1	J1.1
Step 2 - CMD	2	J1.2
Step 3 - CMD	3	J1.3
Step 4 - CMD	4	J1.4
Step 5 - CMD	5	J1.5
ON - CMD	6	J1.6
CCR OFF from HVCS - CMD	7	J1.7
NC	8	J1.8
V-OUT 48V	25	J8.1
GND 48V	9	J8.2
Feedback signals (fixed)		
GND - FB	10	J8.3
GND - FB	NC	J8.4

Table 20: Factory set terminal assignments for remote control connections with multiwire dual J-Bus (Cable Set 4072.30.182) (Continued)

Function	Terminal number on 32-pole connector	Relay number on Remote Control PCB (unless indicated otherwise)
Step 1 - FB	11	J5.1
Step 2 - FB	12	J5.2
Step 3 - FB	13	J5.3
Step 4 - FB	14	J5.4
Step 5 - FB	15	J5.5
ON (step1,2...5) / OFF (OFF or Standby Step 0 - FB)	16	J5.6
Feedback signals (configurable via HMI):		
Disable local/remote NC	NC	J5.7 (NC relay)
	NC	J5.8 (NO relay)
Open circuit - FB	17	J6.1
Overcurrent - FB	18	J6.2
Bad regulation	19	J6.3 (CM)
CM specific return for Relay 11	NC	J6.4
LFD alarm (Relay 11)	NC	J6.5 (NO relay)
NC	NC	J6.6
EFD warning - FB	20	J6.7
EFD error - FB	NC	J6.8
High temperature alarm - FB	NC	J7.1
Short circuit - FB	NC	J7.2
Lamp fault warning - FB	NC	J7.3
(not used)	NC	J7.4
J-Bus interface (fixed)		
RS485 Bus B GND	27	DB92.3
RS485 Bus B-	28	DB92.1
RS485 Data B+	29	DB92.2
RS485 Bus A GND	30	DB9.3
RS485 Data A -	32	DB9.2
RS485 Data A +	31	DB9.1

Figure 32: Multiwire and J-Bus connection

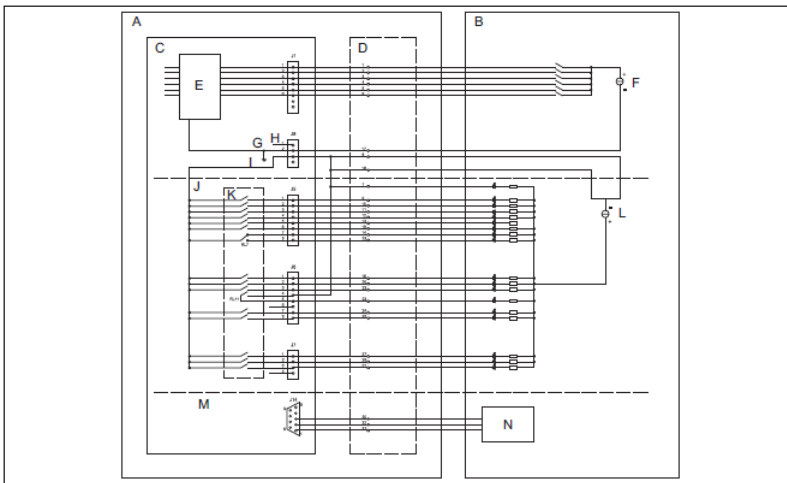

A	Equipment
B	Remote control equipment
C	Remote control PCB - input signals
D	Remote control connector on the equipment
E	Opto coupler
F	48 V DC power supply
G	Isoground
H	+48 V DC I Rel com
J	Remote control PCB - feedback signals
K	Relays
L	24 V DC power supply
M	J-Bus RS485 connection
N	J-Bus RS485 interface

9.4 IGBT PCB (EPS477 / EPS 496)

Figure 33: Printed Circuit Board (PCB) EPS477 for2s Semix

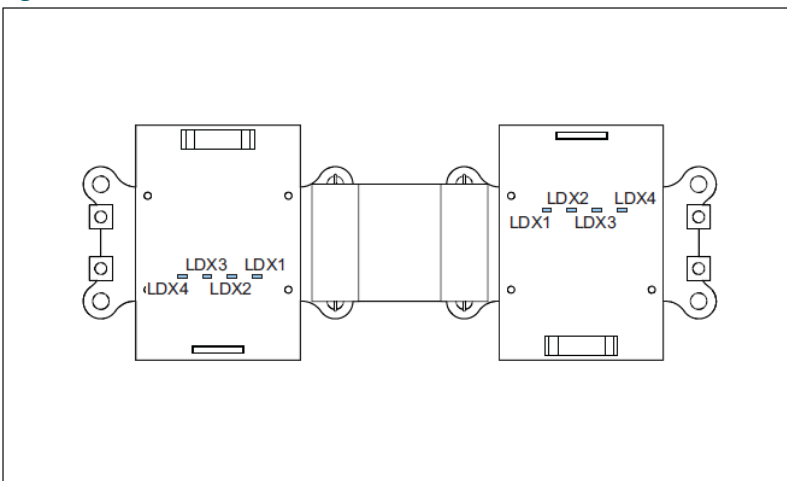

9.4.1 LEDs EPS477 for 2s Semix

Table 21: IGBT PCB LED functions

LED	Color	Function
LDX1	Red	The voltage for the high side IGBT, generated on the PCB, is +18 V DC.
LDX2	Red	The voltage for the high side IGBT, generated on the PCB, is -5 V DC.
LDX3	Red	The voltage for the low side IGBT, generated on the PCB, is +18 V DC.
LDX4	Red	The voltage for the low side IGBT, generated on the PCB, is -5 V DC.

9.4.2 Printed Circuit Board (PCB) EPS496 for 3s Semix

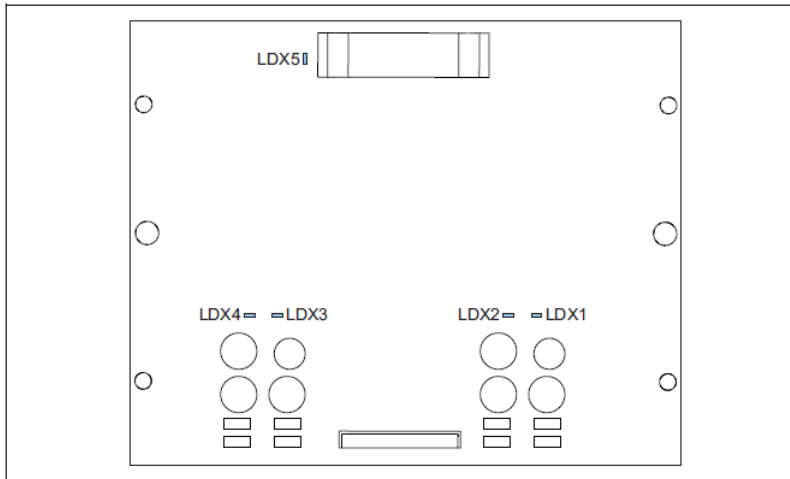

A LDX1 - red

B LDX2 - red

C LDX3 - red

D LDX4 - red

E LDX4 - red

9.4.3 LEDs EPS477 for 1s and 2s Semix

Table 22: IGBT PCB LED functions

LED	Color	Function
LDX1	Red	The voltage for the high side IGBT, generated on the PCB, is +18 V DC.
LDX2	Red	The voltage for the high side IGBT, generated on the PCB, is -5 V DC.
LDX3	Red	The voltage for the low side IGBT, generated on the PCB, is +18 V DC.
LDX4	Red	The voltage for the low side IGBT, generated on the PCB, is -5 V DC.
LDX5	Red	The voltage for logic IC power supply is + 5 V DC.

9.5 Output measure PCB (EPS442)

Figure 34: Printed Circuit Board (PCB)

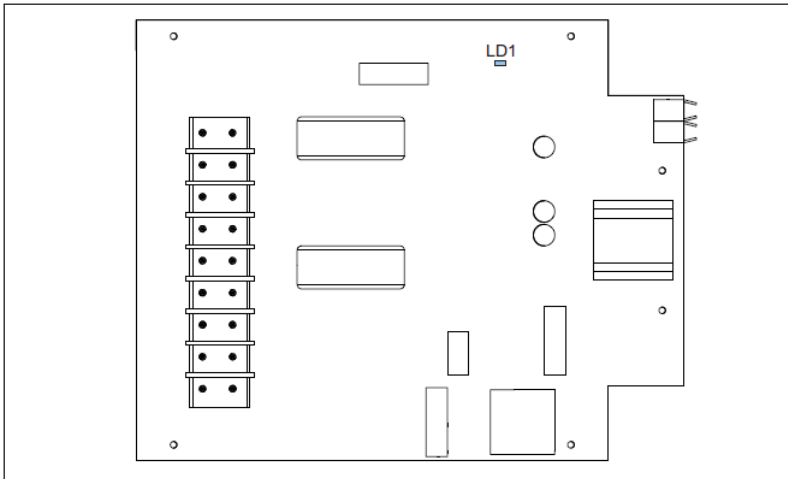

9.5.1 LEDs

Table 23: Phase bridge PCB LED RUN light functions

LED	Color	Function
LD1	Red	Flashes red when the CPU on the PCB is active.

9.6 Diode bridge and sensing PCB (EPS540 / EPS 541 / EPS 497)

Figure 35: Printed Circuit Board (PCB)

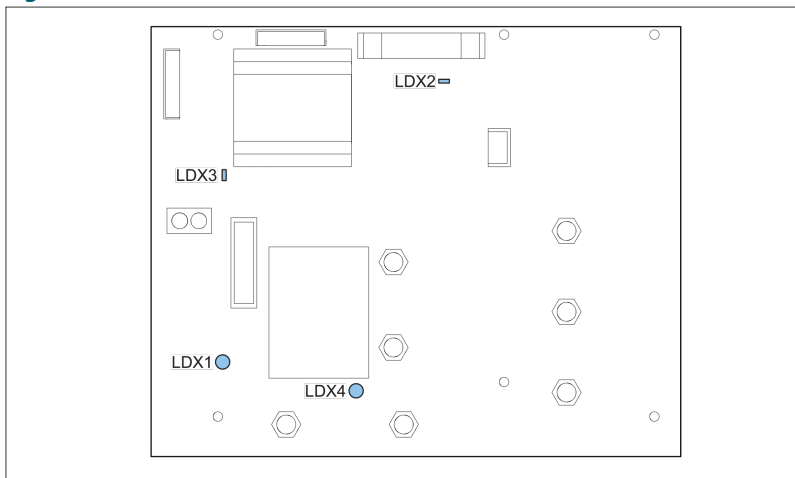

9.6.1 LEDs

Table 24: LEDs - Diode bridge and sensing PCB LED functions

LED	Color	Function
LDX1	Red	The nominal voltage for the IGBT test is 24 V DC
LDX2	Red	The voltage from the power supply PCB is +5 V DC
LDX3	Red	The voltage from the 50 kHz power supply on the PCB is +18 V DC
LDX4	Red	The nominal voltage for the IGBT bridge bus is 560 V DC

9.7 Test parameters

9.7.1 Analog channels

Table 25: Analog channels

Channel	Description	Value range
0	Temperature	17000 - 32000
1	Temperature	27000 - 32000
2	I bridge	100 - 2000
3	V bridge	0 - 30000
4	V in	±31000
5	Aux 1	x = 0
6	Aux 2	x = 0
Ref1	V reference 1	± 54000
Ref2	V reference 2	± 2800

9.7.2 Input

Table 26: Test input parameters

Connector	Function
PB0	Fan 1
PB1	If 1, the Precharge control switch is enabled
PB2	If 1, the Main control switch is enabled
PB3	Fan 2
PB4	If 0, SCO/panel is open
PB5	If 1, BUS fuse is not damaged
PF0	If 0, the overcurrent protection is ON
PF1	If 0, the overcurrent protection is ON

9.7.3 Output

Table 27: Test output parameters

Connector	Function
PE0	0 = Main control switch enabled
PE1	0 = Precharge control switch enabled
PE2	0 = Gate H activation
PE3	1 = Fan enabled
PE4	Display font
PE5	1 = Display back lighting ON
PE6	1 = Red fault LED ON
PE7	1 = Green power LED ON

9.7.4 External input

I0 to I15: Inputs from multiwire PCB.

9.7.5 External output

O0 to O15: Outputs from multiwire PCB.

9.7.6 PIC analog channels

Table 28: PIC analog channels test

Channel	Description
Div_I	Number of divisions of output current
Div_V	Number of divisions of output voltage
EFD	Number of divisions of EFD
Phase	Phase displacement between V and I (x 1000)

10.0 Technical Data

Table 29: Technical Specifications

Item	Description
Rated input voltage [V]	400 V AC ($\pm 10\%$) single phase
Rated frequencies [Hz]	50 or 60
Current regulation limits	Current regulation is guaranteed under the following conditions (± 0.1 A): <ul style="list-style-type: none"> • Under IEC 61822:2009 environmental conditions • For nominal input voltage under IEC or FAA standard conditions • From full load to short circuit
Current regulation modes	Two preset regulation modes: <ul style="list-style-type: none"> • normal mode (for linear loads) • inductive mode (for non-linear loads (e.g. LED loads))
Average efficiency at full load	92 to 94% depending on the size of the equipment, under nominal resistive load, nominal output current, and nominal input voltage
Power factor at output	The power factor exceeds the IEC and FAA requirements. The power factor at rated load is close to 1 and is kept at a high level for possible operational conditions
Brightness steps	5 standard, 8 maximum, fully adjustable in 65k levels (1mA resolution)
Output current [A]	6.6
Remote control and monitoring	<ul style="list-style-type: none"> • Multiwire: <ul style="list-style-type: none"> • Compatible voltage: for units without circuit selector; 24 VDC for units with circuit selector • Internal power supply: 48 VDC for units without circuit selector; 24 VDC for units with circuit selector • Single or dual J-Bus protocol over RS485/RS422 • Single or dual J-Bus protocol over Ethernet IEEE 802.3
Regulation response time	<ul style="list-style-type: none"> • Less than 0.5 seconds • Exceeds the requirements of IEC 61822:2009
Open circuit output voltage	Less than 1.2 times the nominal output voltage (RMS)
Ingress protection	IP 21

Table 30: Output specifications

Type	Rated output power [kW]	RMS output voltage at 6.6 A RMS output current [kV]	Insulated test on output ¹ [kV]	Output overvoltage protection 25kApk
VIS 2.5	2.5	0.38	3	0.75 kV _{RMS} , 1.4 kJ
VIS 4.0	4.0	0.60	5	1.5 kV _{RMS} , 2.8 kJ
VIS 5.0	5.0	0.75	5	1.5 kV _{RMS} , 2.8 kJ
VIS 7.5	7.5	1.13	6	2.2 kV _{RMS} , 4.2 kJ
VIS 10	10	1.50	10	2.2 kV _{RMS} , 4.2 kJ
VIS 15	15	2.30	12	3.0 kV _{RMS} , 5.6 kJ

Table 30: Output specifications (Continued)

Type	Rated output power [kW]	RMS output voltage at 6.6 A RMS output current [kV]	Insulated test on output ¹ [kV]	Output overvoltage protection 25kApk
VIS 20	20	3.00	15	4.5 kV _{RMS} , 8.4 kJ
VIS 25	25	3.80	19	5.2 kV _{RMS} , 9-8 kJ
VIS 30	30	4.54	23	6.0 kV _{RMS} , 11.2 kJ

Notes

¹ Test condition: 50 Hz sinusoidal wave for 1 minute. The test is done without output overvoltage protections.

10.1 Applicable standards

The equipment is in accordance with these standards:

Standard	Description
ICAO	Aerodrome Design Manual, Part 5 paragraphs 3.2. (current edition)
FAA ¹	AC 150/5345-10 (current edition), L-828 and L-829 except for input voltage
IEC	IEC 61822:2009
CENELEC	EN 61822
CE certified	

Notes

¹ The equipment is not FAA equipment but it complies with most of the FAA requirements.

10.2 ElectroMagnetic Compatibility (EMC)

The equipment is designed to operate in an industrial electro-magnetic environment. The regulator complies with IEC 61822:2009, in accordance with IEC 61000-6-4 and IEC 6-6-2 (generic standard for industrial environment). The equipment is, with adapted test levels, in accordance with IEC/TS61000-6-5, G (substation environment, location G).

10.3 Dimensions and mass

Figure 36: The small cabinet (A) and the big cabinet (B)

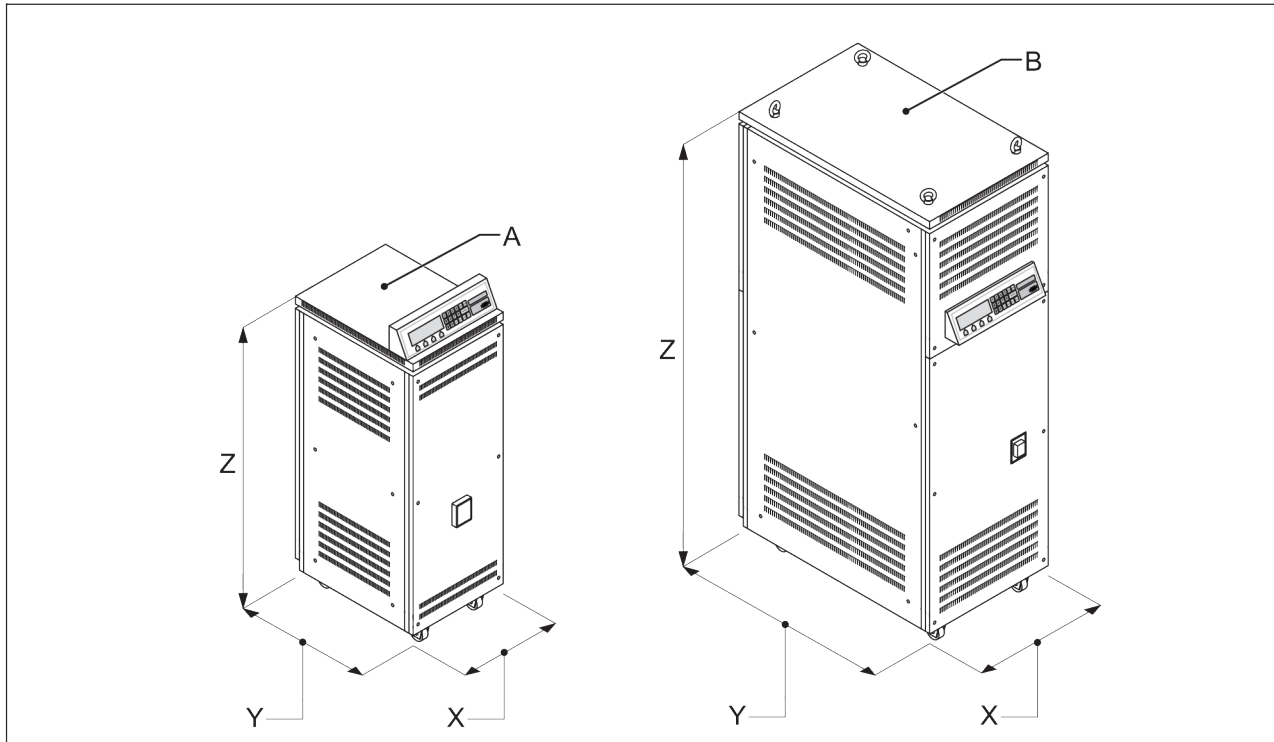

Table 31: Dimensions

Item	A - 2.5 kVA	A - 4 to 15 kVA	B - 20 to 30 kVA
X [mm]	420	420	520
Y [mm] ¹	550	840	840
Z [mm]	1300	1300	1600

Notes

¹ Depending on the output power connection (options)

Table 32: Mass

Type	Net mass	Crate mass	Crate dimensions width x depth x height [mm]
2.5	140	23	1200 x 800 x 1500
4	180	23	1200 x 800 x 1500
5	190	23	1200 x 800 x 1500
7.5	215	23	1200 x 800 x 1500
10	255	23	1200 x 800 x 1500
15	285	23	1200 x 800 x 1500
20	360	40	1200 x 800 x 1850
25	410	40	1200 x 800 x 1850
30	450	40	1200 x 800 x 1850

10.4 Protection devices

Table 33: Protection devices specifications

Equipment type [kVA]	Equipment voltage [V]	Main fuse rating [A]	Manual switch type C rating [A]	Maximum line input current [A]
2.5	380 to 400	16	10	5.9
4		16	16	9.4
5		16	16	11.7
7.5		20	20	17.6
10		50	40	23.4
15		50	40	35.2
20		80	80	46.9
25		80	80	58.6
30		100	100	70.3

10.5 Used brightness steps

All equipments are programmed with five steps by default. You can change the number of required steps. [Table 34](#) shows the current values that the equipment produces at each step, depending on how many steps are programmed.

Example:

The equipment is set to five brightness steps. The default current value set for step 3 is 4.1 A.

Table 34: Current values produced at each brightness step

Brightness step	Default current value [A]					
	No. of steps used					
	3	4	5 (default)	6	7	8
1	4.8	3.3	2.8	2.7	2.2	2.8
2	5.5	4.4	3.4	3.4	2.8	3.1
3	6.6	5.5	4.1	3.9	3.4	3.4
4		6.6	5.2	4.5	4.1	3.9
5			6.6	5.4	5.2	4.6
6				6.6	6.4	5.5
7					6.6	6.4
8						6.6

These values apply when the minimum current is 2.8 A and the maximum current is 6.6 A.

10.6 Ambient conditions

The equipment is air-cooled with fans. Thus, the equipment must have a good airflow, especially if they operate near the maximum temperature.

Table 35: Ambient conditions

Item	Description
Temperature	From -20 up to +55 °C ¹
Altitude	From 0 (sea level) up to 1000 meter
Relative humidity	From 10% up to 95% RH without condensation

Notes

¹ For IEC conformity to -40 °C an optional modification is required.

10.7 Parts list



WARNING

Use only original ADB Safegate spare parts. If you use other spare parts, the specific module or the equipment may be damaged. This can also put personnel in danger.



Note

The parts list may be subject to change without prior notice. Contact ADB Safegate to obtain the latest version.

Part orders

Each part of the equipment has a part number. When you order parts:

- Always mention the part number of the ordered part
- Always mention serial number and type of the equipment. These are indicated on the nameplate of the equipment.

For all spare part orders, contact ADB Safegate or the local representative of ADB Safegate.

Recommendations

To reduce downtime during maintenance, have one or more extra equipment cabinets in stand-by at the substation. This is especially important at major airports, which have a large amount of equipments.

Keep spare parts always in stock. For example:

- Fuses
- Lightning arrestors
- PCBs

10.8 Preventive spare parts

Item	Table
Main fuse	Preventive spare parts
Main contactor	Table 37
Lightning arrestors	Table 38
Overvoltage protection	Table 39
Capacitors	Table 40

Item	Table
Safety switches	Table 41
Fan	Table 42
IGBT bridge	Table 43
Micro control PCB	Table 44
Output measure PCB	Table 45
Power supply PCB	Table 46
Remote control PCB	Table 47
Diode bridge PCB	Table 48
IGBT PCB	Table 49
Precharge PCB	Table 50
Ethernet adapter	Table 51
Display and keyboard	Table 52

Table 36: Preventive spare parts - Main fuse

Description	Part number	Quantity per order								
		2.5	4	5	7.5	10	15	20	25	30
Fuse 16A 10X38 aM	6130.20.150	3	3	3						
Fuse 20A 10X38 aM	6130.20.160				3					
Fuse 50A 14x51 aM	6130.20.210					3	3			
Fuse 80A 22x58 aM	6130.20.280							3	3	
Fuse 100A 22x58 aM	6130.20.300									3

Table 37: Preventive spare parts - Main contactor

Description	Part number	Quantity per order								
		2.5	4	5	7.5	10	15	20	25	30
Contactor LC1D12B7	6148.46.030	2								
Contactor LC1D32B7	6148.46.000		2	2	2	2				
Contactor LC1D40B7	6148.46.010							2	1	1
Contactor LC1D80B7	6148.46.020							1	1	1

Table 38: Preventive spare parts - Lightning arrestors

Description	Part number	Quantity per order								
		2.5	4	5	7.5	10	15	20	25	30
Lightning arrestor SIOV B72232-B751-K1	6314.32.750	2	4	4	4	6	8	10	12	14

Table 39: Preventive spare parts - Overvoltage protection

Description	Part number	Quantity per order								
		2.5	4	5	7.5	10	15	20	25	30
Overvoltage protection V480LA80BP	6314.12.286					1	1			

Table 40: Preventive spare parts - Capacitors

Description	Part number	Quantity per order								
		2.5	4	5	7.5	10	15	20	25	30
CAP. PPA1854100KN polypropylene film +	6322.60.240	2	2	2	2					
CAP. PMC1704500KVR 5uF/700V step 20-25+	6322.60.220					2	2	2	2	2

Table 41: Preventive spare parts - Safety switch

Description	Part number	Quantity per order								
		2.5	4	5	7.5	10	15	20	25	30
Doorswitch EPS: 684	6150.49.060	3	3	3	3	3	3	4	4	4

Table 42: Preventive spare parts - Fan

Description	Part number	Quantity per order								
		2.5	4	5	7.5	10	15	20	25	30
CCR FAN 120x120x38 24vdc ball bearing	7074.10.100						2	6	6	6
CCR FAN connect.cable (15kVA)	6100.15.300						1			

Table 43: Preventive spare parts - IGBT bridge

Description	Part number	Quantity per order													
		400 V							230 V						
		2.5	4	5	7.5	10	15	20	25	30	2.5	2.5	4	5	7.5
Semix 202 GB 12E4s	6351.88.040	2	2	2	2	2	2				2	2	2	2	2
Semix 453 GB 12E4s	6351.88.060							2	2	2					
ISOLAT.M6 0.6kV	6126.12.485							2	2	2					
Semix 341D16s	6351.88.030							1	1	1					

Table 44: Preventive spare parts - CPU PCB

Description	Part number	Quantity per order									
		2.5	4	5	7.5	10	15	20	25	30	
EPS479/5 CRE/VIS CPU pcb:CS00179 rev.1.1	1597.00.000	1	1	1	1						
EPS479/15 CRE/VIS CPU pcb:CS00179 rev1.1	1597.00.010						1	1			
EPS479/30 CRE/VIS CPU pcb:CS00179 rev1.1	1597.00.020								1	1	1

Table 45: Preventive spare parts - Output measure PCB

Description	Part number	Quantity per order								
		2.5	4	5	7.5	10	15	20	25	30
EPS442/2.5 CRE/VIS out.meas.board CS0039 rev.2.2	1597.00.100	1								
EPS442/5 CRE/VIS out.meas.board CS0039 rev.2.2	1597.00.110		1	1						
EPS442/7.5 CRE/VIS out.meas.board CS0039 rev.2.2	1597.00.120				1					
EPS442/10 CRE/VIS out.meas.board CS0039 rev.2.2	1597.00.130					1				
EPS442/15 CRE/VIS out.meas.board CS0039 rev.2.2	1597.00.140						1			
EPS442/20 CRE/VIS out.meas.board CS0039 rev.2.2	1597.00.150							1		
EPS442/30 CRE/VIS out.meas.board CS0039 rev.2.2	1597.00.160								1	1

Table 46: Preventive spare parts - Power supply PCB

Description	Part number	Quantity per order								
		2.5	4	5	7.5	10	15	20	25	30
EPS480/30 VIS pow.sup.board PCB CS00180 rev.1.2 (6 fans, with SHVS)	1597.00.230	1	1	1	1	1	1	1	1	1

Table 47: Preventive spare parts - Remote control PCB

Description	Part number	Quantity per order								
		2.5	4	5	7.5	10	15	20	25	30
EPS495 CRE/VIS communication board PCB CS00190 rev.1.2	1597.00.300	1	1	1	1	1	1	1	1	1

Table 48: Preventive spare parts - Diode bridge and sensing PCBT

Description	Part number	Quantity per order								
		2.5	4	5	7.5	10	15	20	25	30
EPS540/7.5 VIS5000-08 PCB CS00228 rev.1.0 (diode bridge & sensing)	1597.00.441	1	1	1	1					
EPS541 10/15 VIS5000-08 PCB CS00229 rev.1.0 (diode bridge & sensing)	1597.00.451					1	1			
EPS497 CRE20/30 HAIS150-P interface board.CS00192 rev.1.0 (sensing without diode bridge)	1597.00.500							1	1	1
EPS476/30 CRE/VIS 20/ 30KVA PCB CS00176 rev.2.0 (sensing, without diode bridge)	1597.00.421							1	1	1

Table 49: Preventive spare parts - IGBT PCB

Description	Part number	Quantity per order								
		2.5	4	5	7.5	10	15	20	25	30
EPS477 CRE/VIS 2.5/ 15KVA PCB CS00177 rev.1.1 (IGBT driver)	1597.00.510	2	2	2	2	2	2			
EPS478 CRE/VIS 2.5/ 15KVA PCB CS00178 rev.1.0	1597.00.520	1	1	1	1	1	1			
EPS496 CRE/VIS 20/ 30KVA PCB CS00191 rev. 1.0	1597.00.530							2	2	2

Table 50: Preventive spare parts - Precharge PCB

Description	Part number	Quantity per order								
		2.5	4	5	7.5	10	15	20	25	30
EPS546/10 VIS5000-08 4/10KVA CS00234 rev. 1.0 (precharge board)	1597.00.540			1	1	1	1	1	1	1

Table 51: Preventive spare parts - Ethernet adapter

Description	Part number	Quantity per order								
		2.5	4	5	7.5	10	15	20	25	30
EPS542 CRE/VIS ethernet and single ethernet adapter PCB CS00230 rev.1.0	1597.00.600	1	1	1	1	1	1	1	1	1
EPS542 CRE/VIS ethernet and double ethernet adapter PCB CS00230 rev.1.0	1597.00.610	1	1	1	1	1	1	1	1	1

Table 52: Preventive spare parts - Display and keyboard

Description	Part number	Quantity per order								
		2.5	4	5	7.5	10	15	20	25	30
CCR KEYBOARD BOX ASSY. TRIPHASE	4072.30.630	1	1	1	1	1	1	1	1	1

10.9 Corrective spare parts

Item	Table
Manual switch	Table 53
Main fuse housing	Table 54
Line filter	Table 55
Output Filter	Table 56
Capacitors	Table 57
Precharge resistors	Table 58
Main transformer	Table 59
Fan connector cable	Table 60

Table 53: Corrective spare parts - Manual switch

Description	Part number	Quantity per order								
		2.5	4	5	7.5	10	15	20	25	30
S203-C10	6150.90.740	1								
S203-C16	6150.90.540		1	1						
S203-C20	6150.90.550				1					
S203-C25	6150.90.570									
S203-C40	6150.90.620					1	1			
S203-C50	6150.90.590									
S293-C80	6150.90.650							1	1	
S293-C100	6150.90.660									1

Table 54: Corrective spare parts - Main fuse housing

Description	Part number	Quantity per order								
		2.5	4	5	7.5	10	15	20	25	30
Fuse housing 32	6150.90.670	1	1	1	1					
Fuse housing 50	6150.90.730					1	1			
Fuse housing 125	6150.90.680							1	1	1

Table 55: Corrective spare parts - Line filter

Description	Part number	Quantity per order								
		2.5	4	5	7.5	10	15	20	25	30
EMK3012 (3Ph 10 400V)	6115.18.100	1								
EMK3020 (3Ph 20A 400V)	6115.18.110		1	1	1					
EMK3040 3Ph 40A/400V line filter	6115.18.080					1	1			
EMK3050	6115.18.150									
EMK3070 (3Ph 70A/400V line filter)	6115.18.160									
EMK3100 (3 Ph 100A 400V)	6115.18.140							1	1	1
Toroidal inductor 13mH/10A	6166.50.330	1								
Toroidal inductor 16,5mH/16A	6166.50.340		1	1						
Toroidal inductor 10mH/35A	6166.50.320				1					
Inductance 10mH/40A code:1212	6166.50.300					1	1	2	2	2

Table 56: Corrective spare parts - Output filter

Description	Part number	Quantity per order								
		2.5	4	5	7.5	10	15	20	25	30
Toroidal inductor 750uH/15A	6166.50.350	2	2							
Inductance 285uH/40A	6166.50.310			4	6	6	6	12	12	12
CAP. PMC1704500KVR 5uF/700V step 20-25+	6322.60.220					2	2	2	2	2
CAP.30uF 400V Ecofill MLR25PRL 453004591	6322.60.300	1	1	2	2	2	3	6	8	8

Table 57: Corrective spare parts - Capacitors

Description	Part number	Quantity per order								
		2.5	4	5	7.5	10	15	20	25	30
CAP. AYUX-HR472M400DF1 LBK-Int. 4700uF/400V M12	6322.60.200		2	2	2	4	4	6	8	8
CAP. AYUX-HR222M400DC LBK Int. 2200uF/400V M12	6322.60.210	2			2					

Table 58: Corrective spare parts - Precharge resistors

Description	Part number	Quantity per order								
		2.5	4	5	7.5	10	15	20	25	30
Resistor 15K/10W a filo smaltata EPS:529	6310.60.200	2	2	2	2	2	2	6	8	8

Table 59: Corrective spare parts - Main transformer

Description	Part number	Quantity per order								
		2.5	4	5	7.5	10	15	20	25	30
Transf.400Vac out:24V ref:524108	6300.03.430	1	1	1	1	1	1	1	1	1
Transf.100VA 400V/24V-94VA/24V-6VA	6300.03.400	1	1	1	1	1	1			
Transf.200VA 400V/24V-6VA/24V-194VA	6300.03.410								1	1

Table 60: Corrective spare parts - Fan connector cable

Description	Part number	Quantity per order								
		2.5	4	5	7.5	10	15	20	25	30
CCR FAN connect.cable (15kVA)	6100.15.300							1		

Appendix A: SUPPORT

Our experienced engineers are available for support and service at all times, 24 hour/7 days a week. They are part of a dynamic organization making sure the entire ADB SAFEGATE is committed to minimal disturbance for airport operations.

ADB SAFEGATE Support

Technical Support – Global

Customers in Europe, the Middle East, Africa or Asia Pacific are more than welcome to our portal for technical support. Trained in all areas of system issues, troubleshooting, quality control and technical assistance, our highly experienced Technical support specialists are available 24 hours a day, seven days a week to provide assistance over the phone. In the Americas, we also offer live technical support.

Live Technical Support – Americas

If at any time you have a question or concern about your product, contact ADB SAFEGATE's US-based technical support specialists, available 24 hours a day, seven days a week, to assist you via phone.

ADB SAFEGATE Americas Technical Service & Support (US & Canada) : **+1-800-545-4157**

ADB SAFEGATE Americas Technical Service & Support (Canada): **+1-905-631-1597**

ADB SAFEGATE Americas Technical Service & Support (International): **+1-614-861-1304**

We can also be reached via email during regular business hours:

Airfield and Gate: **techservice.us@adbsafegate.com**

Gate: **gateservice.us@adbsafegate.com**

We look forward to working with you!

Before You Call

When you have an airfield lighting or system control system problem, prior to calling, please ensure the following:

- Review the product's manual and troubleshooting guide.
- Be located with the product ready to troubleshoot.
- Have all necessary information available: airport code/company name, customer id number, contact phone number/email address, product/part number.
- Have a *True RMS* meter available and any other necessary tools.

When calling about an issue with Safedock A-VDGS, we can serve you better if you collect the following information before you call:

- Relevant information regarding the issue you are calling about, such as gate number, flight number, aircraft type and time of the event.
- What, if any, actions have been taken to resolve the issue prior to the call.
- If available, provide a CCTV recording of the incident to aid in aligning the information from the Safedock log file.

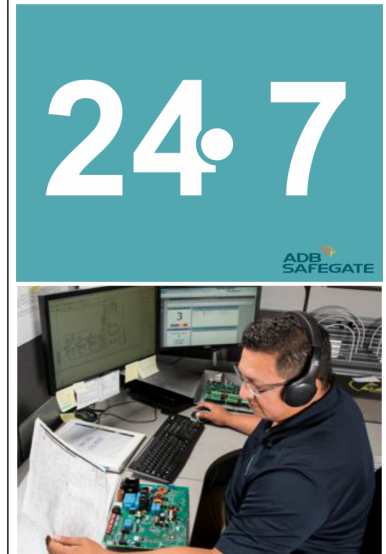

Note

For more information, see www.adbsafegate.com, contact ADB SAFEGATE Support via email at support@adbsafegate.com or

Europe: +32 2 722 17 11

Americas: +1 614 861 1304. Press 3 for technical service or press 4 for sales support.

China: +86 (10) 8476 0106

Middle East and Africa: +971 4 452 7575

A.1 ADB SAFEGATE Website

The ADB SAFEGATE website, www.adbsafegate.com, offers information regarding our airport solutions, products, company, news, links, downloads, references, contacts and more.

A.2 Recycling

A.2.1 ADB SAFEGATE Recycling

ADB SAFEGATE is fully committed to environmentally-conscious manufacturing with strict monitoring of our own processes as well as supplier components and sub-contractor operations. ADB SAFEGATE offers a recycling program for our products to all customers worldwide, whether or not the products were sold within the EU.

ADB SAFEGATE products and/or specific electrical and electronic component parts which are fully removed/separated from any customer equipment and returned will be accepted for our recycling program.

All items returned must be clearly labeled as follows:

- For *ROHS/WEEE* Recycling
- Sender contact information (Name, Business Address, Phone number).
- Main Unit Serial Number.

ADB SAFEGATE will continue to monitor and update according for any future requirements for *EU directives* as and when *EU member states* implement new *regulations* and or *amendments*. It is our aim to maintain our *compliance plan* and assist our customers.

A.2.1.1 Local Authority Recycling

The disposal of ADB SAFEGATE products is to be made at an applicable collection point for the recycling of electrical and electronic equipment. The correct disposal of equipment prevents any potential negative consequences for the environment and human health, which could otherwise be caused by inappropriate waste handling. The recycling of materials helps to conserve natural resources. For more detailed information about recycling of products, contact your local authority city office.



Powering Your Airport Performance from Approach to Departure

adbsafegate.com

Copyright © ADB SAFEGATE, all rights reserved

