



Model 9620

Compact Weather Stations

PRODUCT MANUAL
9620/Rev C

**ADB
SAFEGATE**

A.0 Disclaimer / Standard Warranty

CE certification

The equipment listed as CE certified means that the product complies with the essential requirements concerning safety and hygiene. The European directives that have been taken into consideration in the design are available on written request to ADB SAFEGATE.

ETL certification

The equipment listed as ETL certified means that the product complies with the essential requirements concerning safety and C22.2 No.180:13 (R2018) regulations. The CSA directives that have been taken into consideration in the design are available on written request to ADB SAFEGATE.

All Products Guarantee

ADB SAFEGATE will correct by repair or replacement per the applicable guarantee below, at its option, equipment or parts which fail because of mechanical, electrical or physical defects, provided that the goods have been properly handled and stored prior to installation, properly installed and properly operated after installation, and provided further that Buyer gives ADB SAFEGATE written notice of such defects after delivery of the goods to Buyer. Refer to the Safety section for more information on Material Handling Precautions and Storage precautions that must be followed.

ADB SAFEGATE reserves the right to examine goods upon which a claim is made. Said goods must be presented in the same condition as when the defect therein was discovered. ADB SAFEGATE further reserves the right to require the return of such goods to establish any claim.

ADB SAFEGATE's obligation under this guarantee is limited to making repair or replacement within a reasonable time after receipt of such written notice and does not include any other costs such as the cost of removal of defective part, installation of repaired product, labor or consequential damages of any kind, the exclusive remedy being to require such new parts to be furnished.

ADB SAFEGATE's liability under no circumstances will exceed the contract price of goods claimed to be defective. Any returns under this guarantee are to be on a transportation charges prepaid basis. For products not manufactured by, but sold by ADB SAFEGATE, warranty is limited to that extended by the original manufacturer. This is ADB SAFEGATE's sole guarantee and warranty with respect to the goods; there are no express warranties or warranties of fitness for any particular purpose or any implied warranties of fitness for any particular purpose or any implied warranties other than those made expressly herein. All such warranties being expressly disclaimed.

Standard Products Guarantee

Products manufactured by ADB SAFEGATE are guaranteed against mechanical, electrical, and physical defects (excluding lamps) which may occur during proper and normal use for a period of two years from the date of ex-works delivery, and are guaranteed to be merchantable and fit for the ordinary purposes for which such products are made.

NOTE



See your applicable sales agreement for a complete warranty description.

Replaced or repaired equipment under warranty falls into the warranty of the original delivery. No new warranty period is started for these replaced or repaired products.

FAA Certified products manufactured by ADB SAFEGATE

ADB SAFEGATE L858 Airfield Guidance Signs are warranted against mechanical and physical defects in design or manufacture for a period of 2 years from date of installation, per FAA AC 150/5345-44 (applicable edition).

ADB SAFEGATE LED products (with the exception of obstruction lighting) are warranted against electrical defects in design or manufacture of the LED or LED specific circuitry for a period of 4 years from date of installation, per FAA EB67 (applicable edition). These FAA certified constant current (series) powered LED products must be installed, interfaced and powered with and through products certified under the FAA Airfield Lighting Equipment Program (ALECP) to be included in this 4 (four) year warranty. This includes, but is not limited to, interface with products such as Base Cans, Isolation Transformers, Connectors, Wiring, and Constant Current Regulators.

Revision History

Revision	Date	Summary of Changes
A	2015 June 25	Initial release.
B	2016 Jan 27	Mandated that all stations with wind sensor (Models 9620, 9623, 9624, 9626) get North alignment (Sections 3.3 and 7)
C	2025 Apr 1	ADB SAFEGATE (ECP#ADBSG-0001)

Contents

1. Overview	6
1.1 Models.....	6
1.2 Accessories	6
2. Theory Of Operation	7
2.1 Air Temperature And Humidity.....	7
2.2 Air Pressure.....	8
2.3 Precipitation	8
2.4 Wind.....	8
2.4.1 Compass.....	8
2.5 Global Radiation.....	8
3. Installation.....	9
3.1 Selecting The Installation Location	9
3.1.1 Wind Speed/Direction (Models 9620, 9623, 9624, 9626)	9
3.1.2 Compass (Models 9620, 9623, 9624, 9626).....	10
3.1.3 Radar Precipitation Measurement (Models 9622 and 9624).....	10
3.1.4 Global Radiation Measurement (Models 9625 and 9626).....	10
3.2 Mechanical Installation	11
3.3 North Alignment	13
3.4 Default Configuration.....	14
3.5 Electrical Connections	14
3.5.1 Summary of Signal and Power Wiring Connections	15
4. Operation With An Awos	16
4.1 Sensor Reports.....	16
4.1.1 Topic-Based Sensor Poll Commands.....	16
4.1.2 Check Sum Calculation	17
5. Standalone Measurement Outputs	19
5.1 Measurements Generated	19
5.1.1 Current Measurement (act).....	19
5.1.2 Minimum and Maximum Values	19
5.1.3 Average Value	19
5.1.4 Vectorial Average Value (vct).....	19
5.2 Air And Dew Point Temperature.....	19
5.3 Wind Chill Temperature.....	20
5.4 Humidity.....	20
5.5 Air Pressure.....	20
5.6 Wet Bulb Temperature	21
5.7 Wind Speed.....	21
5.8 Wind Direction.....	22
5.9 Wind Measurement Quality.....	23
5.10 Compass.....	23

9620 Series Compact Weather Stations

5.11 Precipitation Quantity — Absolute.....	24
5.12 Precipitation Quantity — Differential	24
5.13 Precipitation Intensity.....	24
5.14 Precipitation Type.....	25
5.15 Heating Temperatures	25
5.16 Global Radiation.....	25
6. Configuration	26
7. Maintenance	27
8. Troubleshooting.....	28
9. Specifications	29
10. Warranty	32

1. Overview

The 9620 Series of Compact Weather Stations provides low-cost, light-weight weather stations that can collect a variety of meteorological data based on the specific data you need. The portable design of the 9620 Series makes this series of Compact Weather Stations ideal for a variety of unique applications while providing the same level of accuracy and dependability that you get with ADB Safegate's existing modular sensors.

The 9620 Series of Compact Weather Stations may be used on a standalone basis connected to your own data logging system, or may be connected to either ADB Safegate. Model 1191-I Data Collection Platform or Model 2715 Universal Power and Communication Module. Both ADB Safegate. units provide a power, communication, and data aggregation capability to allow the 9620 Series of Compact Weather Stations to be used an automated weather observation system.

1.1 Models

The following models are available.

Model	Weather Parameter					
	Temp/ Humidity	Pressure	Precipitation	Wind Speed/ Direction	Compass	Solar Radiation
9620				X	X	
9621	X	X				
9622	X	X	X			
9623	X	X		X	X	
9624	X	X	X	X	X	
9625	X	X				X
9626	X	X		X	X	X

1.2 Accessories

The following accessories and replacement parts are available for the 9620 Series of Compact Weather Stations.

Part Number	Description
M488628-00	Tower Crossarm Mounting Kit

2. Theory Of Operation

Each weather parameter is measured using a technology that is suited to measuring that parameter, and has become well-established measuring that parameter in standalone systems.

9620 Series models that measure precipitation or wind speed/direction are heated for operation in freezing conditions.

The measured values are sent over an RS-485 interface in accordance with UMB protocol. The Weather Station is polled once a second, and sends the weather data in response to the poll.

Figure 1. shows the possible Compact Weather Station sensors.

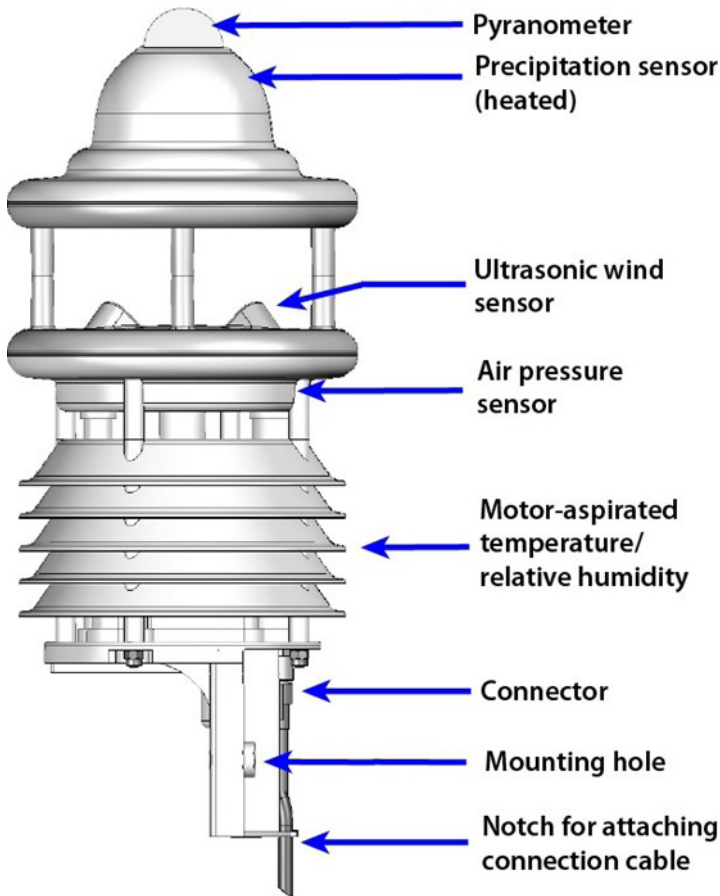

Figure 1. Possible Compact Weather Station Sensors



NOTE

Not all the sensors will be present on a given Compact Weather Station model.

2.1 Air Temperature And Humidity

Temperature is measured using a highly accurate NTC thermistor whose resistance varies with temperature. Relative humidity is measured using a capacitive humidity sensor. In order to keep the effects of external influences such as solar radiation as low as possible, these sensors are located in a motor-aspirated housing with radiation protection. In contrast to conventional non-ventilated sensors, this allows significantly more accurate measurement during high-radiation conditions.

The dew point is calculated from the air temperature and relative humidity readings.

2.2 Air Pressure

The air pressure is measured using a built-in MEMS (microelectromechanical) capacitive sensor. The altimeter setting and relative air pressure referenced to sea level can be calculated using the known elevation of the sensor above mean sea level, which is user-configurable on the equipment.

2.3 Precipitation

Precipitation is measured by the R2S-UMB sensor, which uses radar technology to measure precipitation. The sensor works with a 24 GHz Doppler radar that measures the drop speed and calculates the precipitation quantity and type by correlating the drop size and speed.



NOTE

This method of measuring precipitation has not been approved by aviation authorities in some countries.

2.4 Wind

Wind speed and direction are derived using measurements from four ultrasonic transducers. The transducers are located at 90° intervals, and are oriented north/south and east/west. The transducers emit sound waves that are detected by the opposite transducers, and wind affects the travel times of the sound waves. This information can then be used to calculate the vector components of the wind speed and the wind direction relative to true north.

2.4.1 Compass

The integrated electronic compass is used to check the north/south adjustment of the sensor housing for wind direction measurements. It is also used to calculate the compass-corrected wind direction (wind direction relative to magnetic north).

2.5 Global Radiation

Global radiation is measured by a pyranometer mounted in the top cover of the Compact Weather Station.

3. Installation

3.1 Selecting The Installation Location

Pay attention to the following points when selecting the installation location.

- Stable subsurface for installing the mast foundation
- Reliable power supply
- The mast and the sensor must be grounded in accordance with regulations

The following sections provide siting guidelines for each sensor model.



SUGGESTION

Take a picture at the installation site in each direction (north, east, south, and west) to record the topography and obstructions for future reference.

3.1.1 Wind Speed/Direction (Models 9620, 9623, 9624, 9626)

Buildings, bridges, and trees may corrupt the wind measurement. Equally, passing traffic may cause gusts that may influence the wind measurement.

- The standard exposure of wind instruments over level open terrain is 10 m above the ground. Open terrain is defined as an area where the distance between the sensor and any obstruction is at least 10 times the height of the obstruction.

Figure 2. shows the minimum siting considerations (height above ground, distance from obstructions and roads) for a weather station monitoring wind speed/direction.

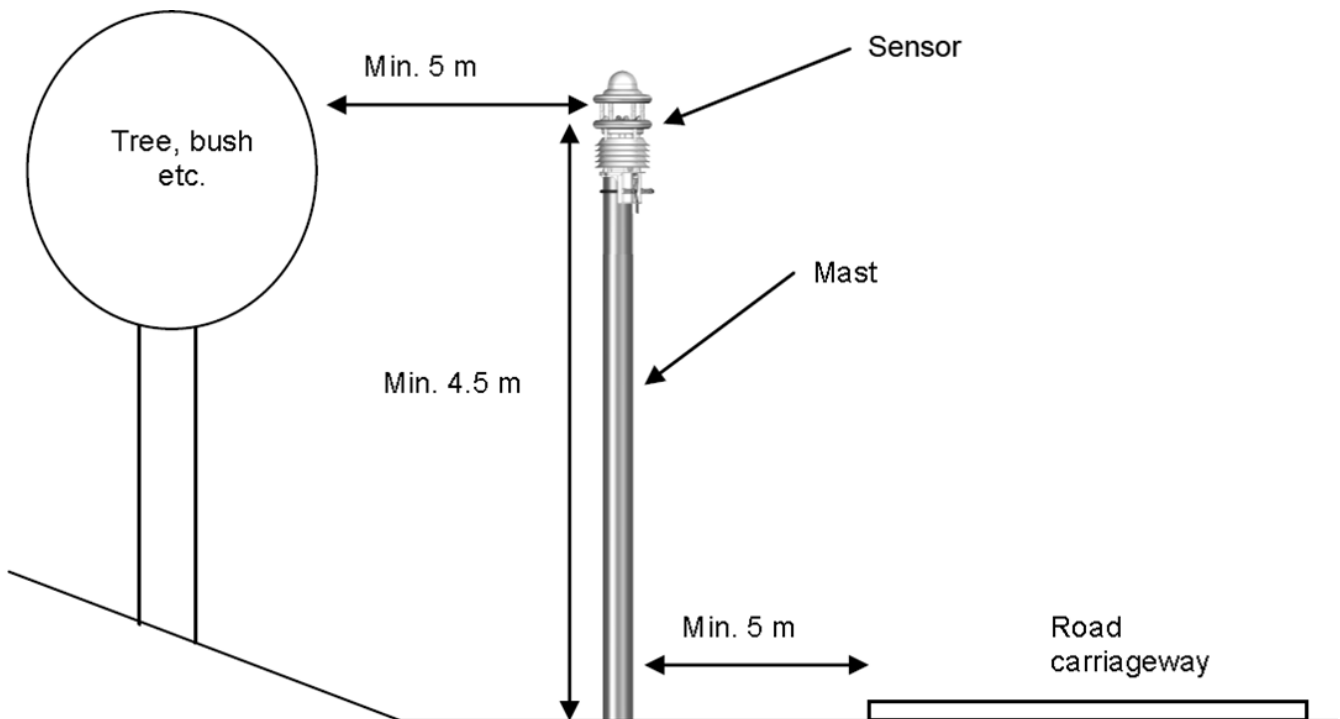

Figure 2. Minimum Siting Considerations for Wind Speed/Direction

3.1.2 Compass (Models 9620, 9623, 9624, 9626)

An aluminum or other nonferrous mast is recommended for mounting a weather station with a compass.

3.1.3 Radar Precipitation Measurement (Models 9622 and 9624)

Pay attention to the following points when selecting the installation location for a weather station with radar precipitation measurement.

- Installation at the top of the mast
- Installation height at least 4.5 m above the ground
- Distance to road carriageway at least 10 m
- Distance from moving objects (e.g., trees, bushes and even bridges) at least 10 m at the height of the sensor

Falling or moving objects, even falling leaves or leaves blowing in the wind, may cause false measurements and/or precipitation types. Strong winds can influence the accuracy of the precipitation measurements.

When selecting the installation location, take care to position the weather station at a suitable distance from other systems incorporating 24 GHz radar, such as traffic counting devices on overhead gantry signs. Otherwise cross effects and system malfunctions may occur. In the final analysis, the distance to other measuring systems also depends on their range of coverage and signal strength.

3.1.4 Global Radiation Measurement (Models 9625 and 9626)

Pay attention to the following points when selecting the installation location for a weather station with a pyranometer.

- Installation at the top of the mast
- Shadow-free location, if possible 360° free view to the horizon at the height of the pyranometer
- Distance to shadow-casting objects (trees, buildings) at least 10 times of the object height relative to the pyranometer

3.2 Mechanical Installation

There are two installation options for the 9620 Series of Compact Weather Stations.

- U-bolt mounting bracket to mast (included)
- Crossarm to tower (optional accessory)

For the mast option, the sensor base is designed to be installed on the top of a mast with a diameter of 60 to 76 mm using a mounting bracket.

1. Loosen nuts.
2. Push the sensor from above onto the top of the mast.
3. Tighten the nuts evenly until contact is made with the springs but the sensor can still be moved easily.
4. For weather stations measuring wind speed/direction, align the sensor to the North.
5. Tighten both nuts with 3 complete turns.

Figure 3. Illustrates the installation of the weather station on a mast.

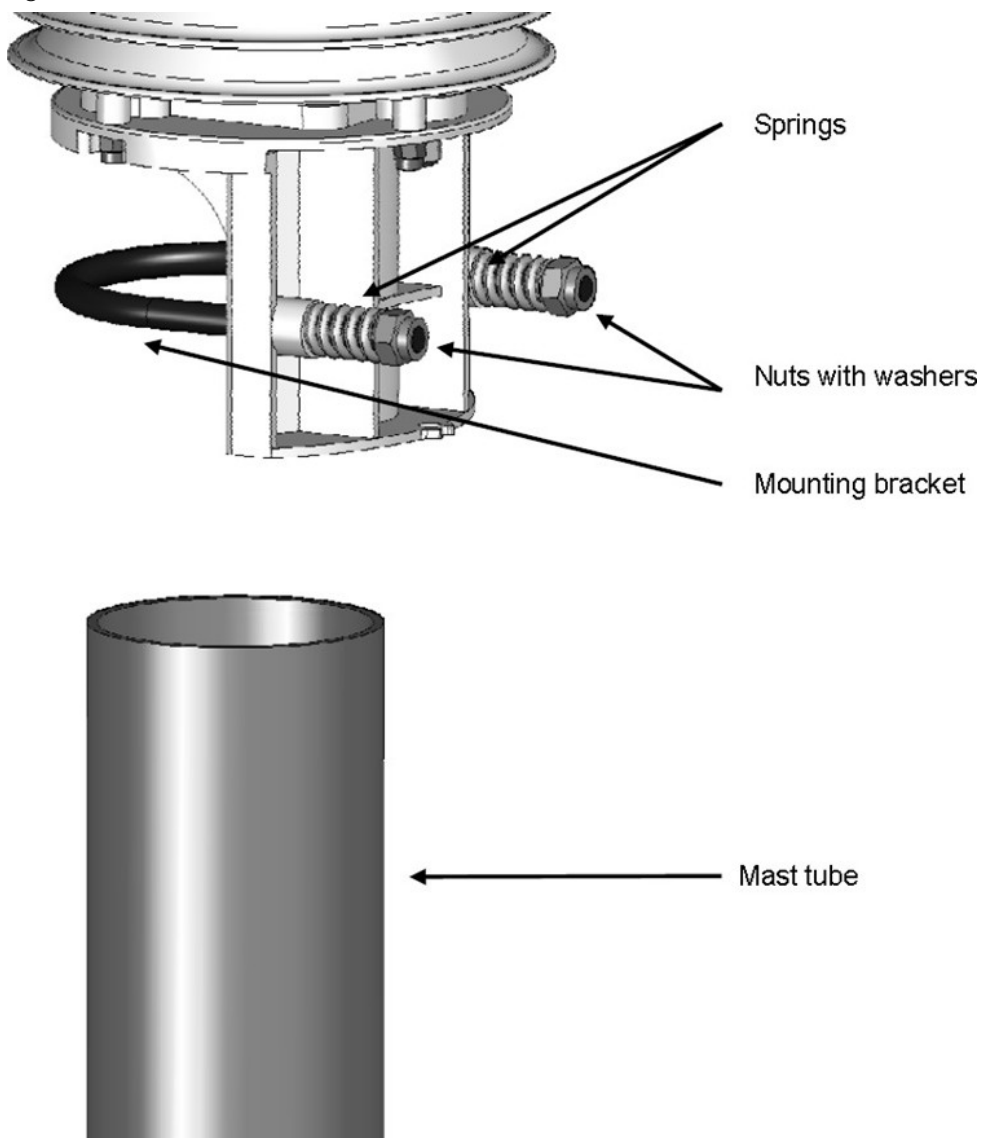

Figure 3. Install Compact Weather Station on Mast

9620 Series Compact Weather Stations

For the tower crossarm option, the sensor base is attached to a mounting bracket on the crossarm.

1. Position the crossarm next to the tower where the crossarm will be mounted.

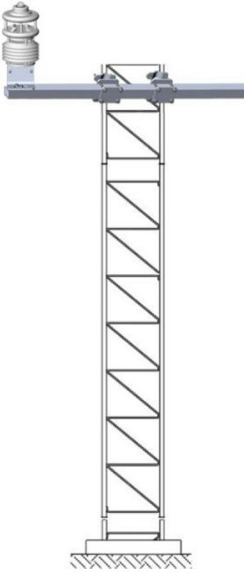

Figure 4. Position Crossarm for Mounting

2. Each of the two mounting braces has independent mounts so that the brace can be attached to the tower independently of positioning the crossarms in the braces. Use a carpenter's level to keep the crossarm as level as possible while securing each brace to a tower leg.
3. Position the crossarm in the brace so that the area where the weather station will be mounted is at the desired distance from the tower.
4. Position the weather station on the mounting plate at the end of the crossarm.
5. Tighten all the mounting nuts, except for weather stations measuring wind speed/ direction (Models 9620, 9623, 9624, 9626).

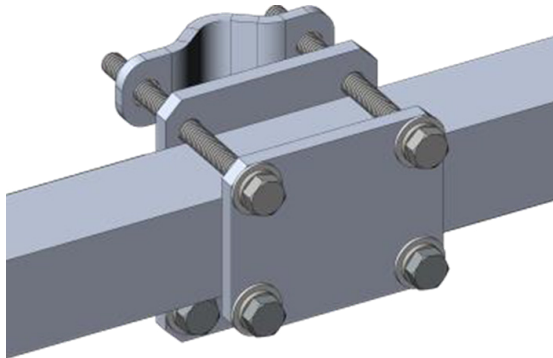

Figure 5. Mounting Brace Detail

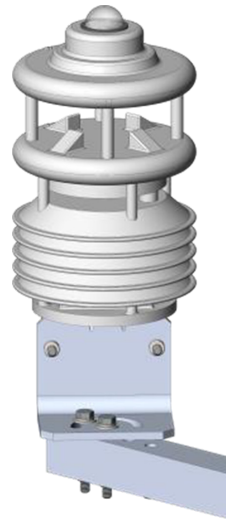

Figure 6. Mount the Weather Station

3.3 North Alignment

In order for wind direction to display correctly on weather stations with wind speed/direction (Models 9620, 9623, 9624, 9626), the weather station must be aligned with the North benchmark. This benchmark should already have been marked as part of the site preparation activities. The benchmark should be at least 30 m (100 ft) from the tower in the True North direction.

The weather station has a number of directional arrows for this purpose as shown in Figure 7.

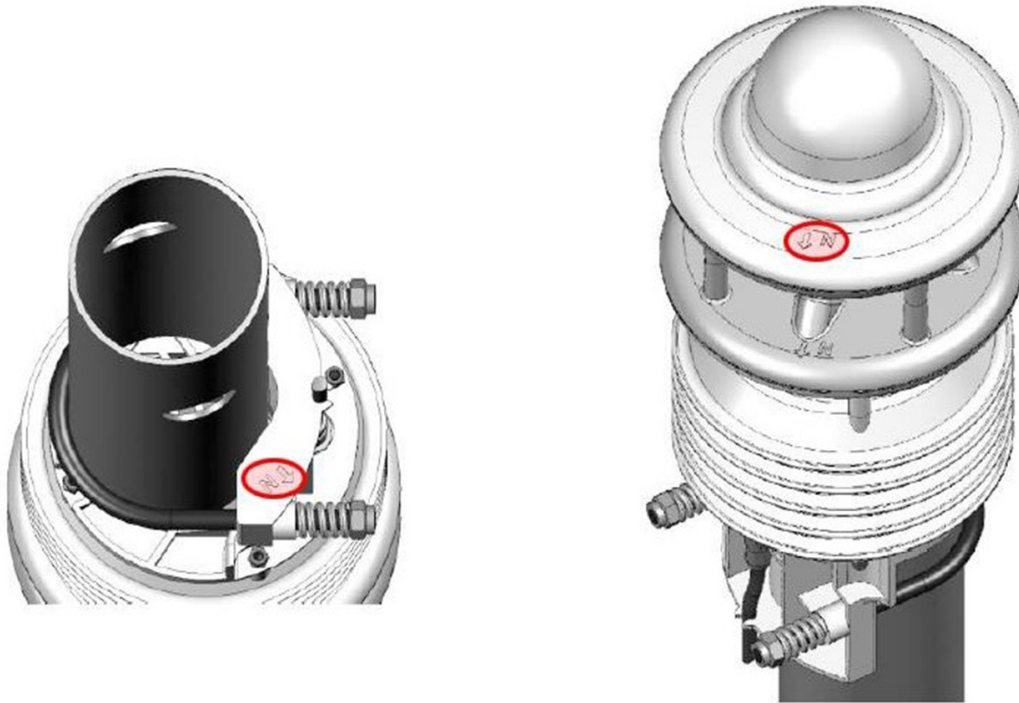

Figure 7. North Alignment Markings

1. If the weather station is already secured, first loosen both nuts evenly until you can turn the weather station easily.
2. Position the weather station in such a way that the South and North transducers are aligned with the fixed point of reference in the North (see Figure 8).
3. Tighten the mounting nuts.

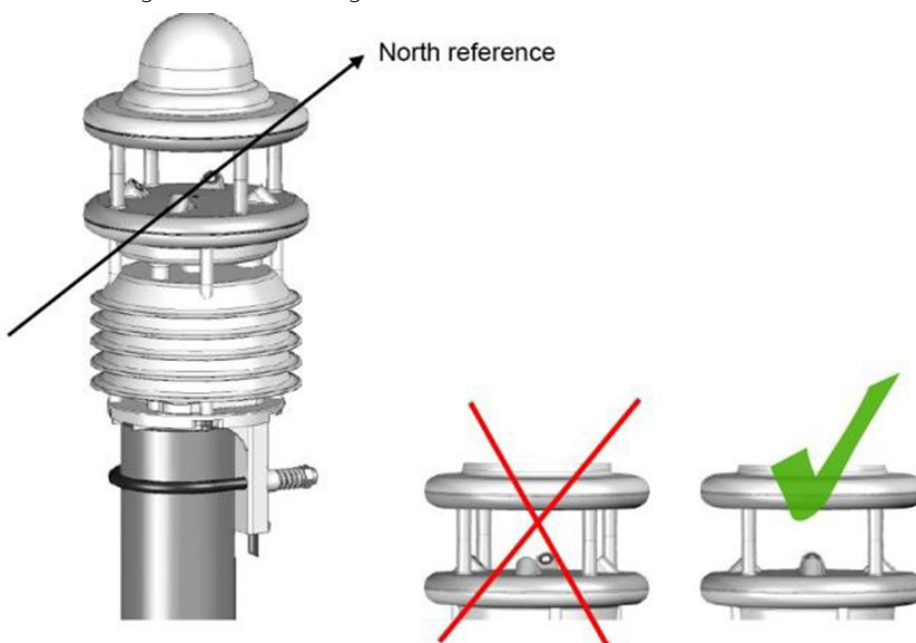

Figure 8. Correct Magnetic North Alignment

3.4 Default Configuration

Baud Rate	19200 bps
RS-485	Binary
Calculation Interval	10 measurements
Elevation Above MSL	0 m

Table 1. Default Configuration

3.5 Electrical Connections

There is an 8-pole screw connector on the bottom side of the weather station as shown in Figure 9. This serves to provide the supply voltage and serial interface by way of the supplied connection cable.

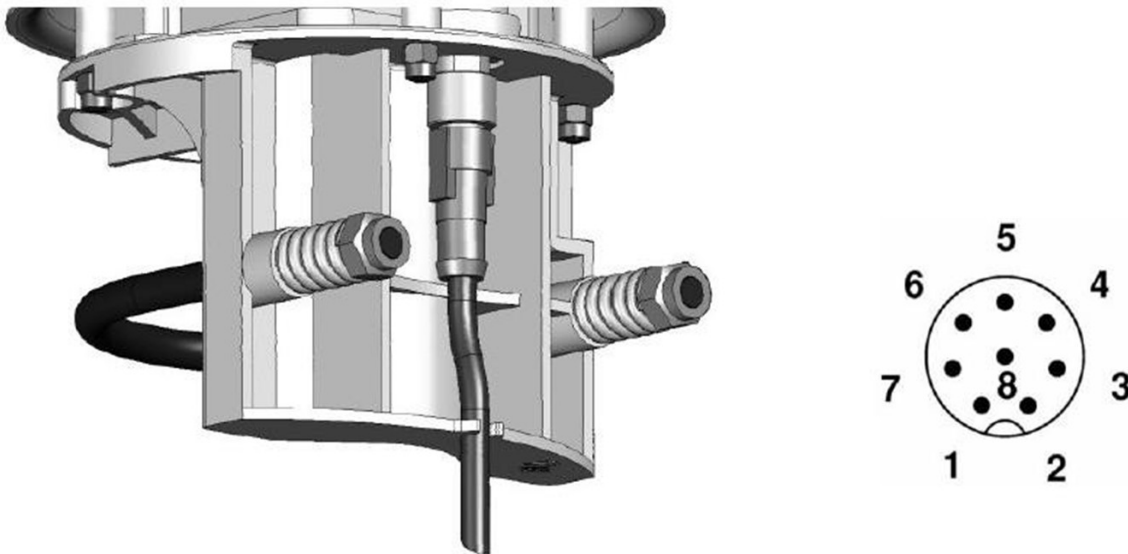

Figure 9. Sensor Electrical Connections

Pin	Color	Function
1	White	Power Supply GND
2	Brown	Power Supply +
3	Green	RS-485 (D+)
4	Yellow	RS-485 (D-)
7	Blue	Heater GND
8	Red	Heater +

3.5.1 Summary of Signal and Power Wiring Connections

Table 2 provides the serial connections for the default half-duplex RS-485 serial communication option. The Model 2715 Universal Power and Communication Module may also be configured to provide RS-232 or full-duplex RS-485 signals at Serial Output 1. The Model 2715 Universal Power and Communication Module User’s Manual describes these wiring options and explains how to install the required firmware to support these options.

Serial Output 2 Pin	Function	Color
1	+ 24 V DC	BROWN RED
2	PGND	WHITE BLUE
3	RS-485 (D-)	YELLOW
4	RS-485 (D+)	GREEN
Serial Output 1 Pin	Function	Color
3	RS485 (D-)	Any colors may be used as long as they match the signals on each end of the connection.
4	RS485 (D+)	
5	GROUND	
DC Power Pin	Function	Color
5	Battery +	RED
6	Battery -	BLACK
AC Pin	Function	Color
1	HOT	BLACK
2	NEUTRAL	WHITE
3	GROUND	GREEN

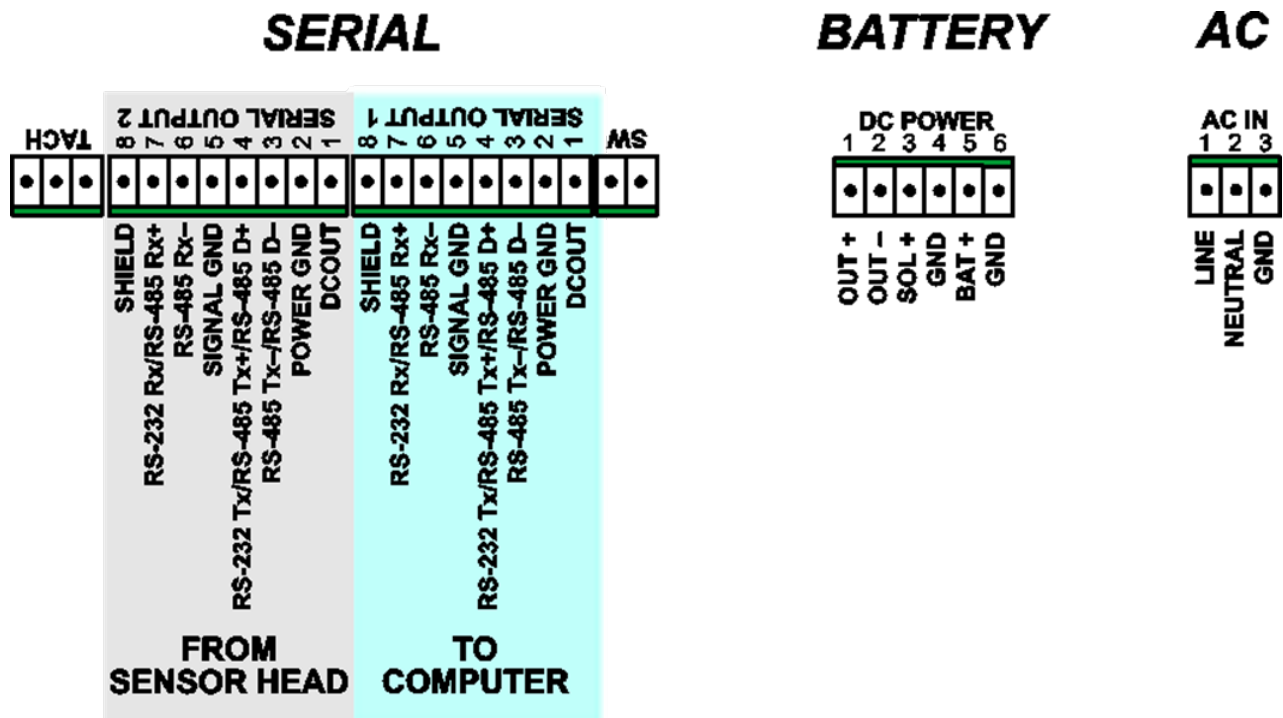

Table 2. Model 9620 Series Compact Weather Station Signal and Power Wiring

4. Operation With An Awos

4.1 Sensor Reports

The 9620 Series of Compact Weather Stations is a polled sensor and the sensor responds when it is polled by the computer. The Model 2715 Universal Power and Communication Module (UPCM) supplies power to the weather station and provides a communication interface with the data processing computer. The communication interface can be either serial or TCP/IP.

Data transfer across the serial interface between the UPCM and the computer is implemented by default via a serial, ASCII encoded, half duplex, 4800 bps, 8-N-1. This allows for the data to go on the data bus for the Data Collection Platform.

4.1.1 Topic-Based Sensor Poll Commands

These Topic-based poll commands from the data processing computer are used to poll sensors connected to the UPCM.

A Topic-based poll command has the following format.

PWRaaTOPIC 110|120|130|150|...|1174, <CRC> <CR> <LF>

where aa is the address of the sensor or the sensor location. This address is often 00. The topics being polled are then listed based on the specific weather station model connected to the UPCM, and the specific topics that are to be polled. Note that there is a pipe between each topic that is being polled. See the notes below Table 8 for more information about Topic 1301.

The response to the poll will be a string formatted according to the response formats specified for the topics.

**=PWRaaTOPIC 110=xxx.xx|120=xxx|130=xxx.xx|150=xx|...
|1174= xxx.xx<EOF> <CRC> <CR> <LF>**

where EOF is the end of file marker.

The CRC is a 4-character CRC that is calculated as explained later in this chapter.

The specific topics are explained in the tables below.

110	Instant wind speed	xxx.xx
120	Instant wind direction	xxx

Table 3. Ultrasonic Wind Sensor Poll Topics (Models 9620, 9623, 9624, 9626)

210	Instant temperature (°C)	xxx.xx	230	Instant dew point (°C)	xxx.xx
220	Instant relative humidity	xxx	250	Alarm byte	x

Table 4. Temperature/Relative Humidity Poll Topics (Models 9621, 9622, 9623, 9624, 9625, 9626)

312	Pressure (in Hg)	xxx.xx
-----	------------------	--------

Table 5. Barometric Pressure Sensor Poll Topics (Models 9621, 9622, 9623, 9624, 9625, 9626)

612	Precipitation ID	xx	621	Accumulation (mm/h)	xx.xx
-----	------------------	----	-----	---------------------	-------

Table 6. Precipitation Poll Topics (Models 9622, 9624)

1174	Solar radiation (W/m2)	xxx.xx
------	------------------------	--------

Table 7. Analog Topics (Models 9625, 9626)

1385	Model 9620 Series Status Word	xx
------	-------------------------------	----

Table 8. Ancillary Topics

4.1.2 Check Sum Calculation

The CRC is calculated using a standard crc-16 formula. The algorithm is as follows.

```

/* CRC routine used with AWOS remote sensors

USE:  crc = crcl6(buffer, length, initial_value)

where:  crc is the returned value,
        buffer is the data buffer to compute a crc
        length is the number of bytes in buffer to process
        initial_value is the results of previous crc calculations
        that will allow the buffer crc to be computed in
        stages if necessary. If this is not necessary,
        then set initial_value to 0.

*/

unsigned int crcl6(char *string, unsigned int length, unsigned int ival)

/* buffer address to compute a crc */
/* number of characters to process */
/* initial value of crc          */
{

    static unsigned int crc;

    /*   CRC values for crcl6 routine                               */

    static unsigned int crc_vals[] =
    {
        0x0000,0xc0c1,0xc181,0x0140,0xc301,0x03c0,0x0280,0xc241,
        0xc601,0x06c0,0x0780,0xc741,0x0500,0xc5c1,0xc481,0x0440,
        0xcc01,0x0cc0,0x0d80,0xcd41,0x0f00,0xcfcl,0xce81,0x0e40,
        0x0a00,0xcac1,0xcb81,0x0b40,0xc901,0x09c0,0x0880,0xc841,
        0xd801,0x18c0,0x1980,0xd941,0x1b00,0xdbcl,0xda81,0x1a40,
        0x1e00,0xdecl,0xdf81,0x1f40,0xdd01,0x1dc0,0x1c80,0xdc41,
        0x1400,0xd4c1,0xd581,0x1540,0xd701,0x17c0,0x1680,0xd641,
        0xd201,0x12c0,0x1380,0xd341,0x1100,0xd1c1,0xd081,0x1040,
        0xf001,0x30c0,0x3180,0xf141,0x3300,0xf3c1,0xf281,0x3240,
        0x3600,0xf6c1,0xf781,0x3740,0xf501,0x35c0,0x3480,0xf441,
        0x3c00,0xfccl,0xfd81,0x3d40,0xff01,0x3fc0,0x3e80,0xfe41,
        0xfa01,0x3ac0,0x3b80,0xfb41,0x3900,0xf9c1,0xf881,0x3840,
        0x2800,0xe8c1,0xe981,0x2940,0xeb01,0x2bc0,0x2a80,0xea41,
        0xee01,0x2ec0,0x2f80,0xef41,0x2d00,0xedc1,0xec81,0x2c40,
        0xe401,0x24c0,0x2580,0xe541,0x2700,0xe7c1,0xe681,0x2640,
        0x2200,0xe2c1,0xe381,0x2340,0xe101,0x21c0,0x2080,0xe041,
        0xa001,0x60c0,0x6180,0xa141,0x6300,0xa3c1,0xa281,0x6240,
        0x6600,0xa6c1,0xa781,0x6740,0xa501,0x65c0,0x6480,0xa441,
        0x6c00,0xaccl,0xad81,0x6d40,0xaf01,0x6fc0,0x6e80,0xae41,
        0xaa01,0x6ac0,0x6b80,0xab41,0x6900,0xa9c1,0xa881,0x6840,
        0x7800,0xb8c1,0xb981,0x7940,0xbb01,0x7bc0,0x7a80,0xba41,
        0xbe01,0x7ec0,0x7f80,0xbf41,0x7d00,0xbdcl,0xbc81,0x7c40,
        0xb401,0x74c0,0x7580,0xb541,0x7700,0xb7c1,0xb681,0x7640,
    }

```

```
0x7200,0xb2c1,0xb381,0x7340,0xb101,0x71c0,0x7080,0xb041,  
0x5000,0x90c1,0x9181,0x5140,0x9301,0x53c0,0x5280,0x9241,  
0x9601,0x56c0,0x5780,0x9741,0x5500,0x95c1,0x9481,0x5440,  
0x9c01,0x5cc0,0x5d80,0x9d41,0x5f00,0x9fc1,0x9e81,0x5e40,  
0x5a00,0x9ac1,0x9b81,0x5b40,0x9901,0x59c0,0x5880,0x9841,  
0x8801,0x48c0,0x4980,0x8941,0x4b00,0x8bc1,0x8a81,0x4a40,  
0x4e00,0x8ec1,0x8f81,0x4f40,0x8d01,0x4dc0,0x4c80,0x8c41,  
0x4400,0x84c1,0x8581,0x4540,0x8701,0x47c0,0x4680,0x8641,  
0x8201,0x42c0,0x4380,0x8341,0x4100,0x81c1,0x8081,0x4040};
```

```
crc = ival;  
while(length--)  
    crc = crc_vals[(*string++ ^ crc) & 0xff] ^ ((crc >> 8) & 0xff);  
return crc;  
}  
  
/* end crc16 routine */
```

5. Standalone Measurement Outputs

Measurements are transmitted in accordance with the UMB binary protocol.

5.1 Measurements Generated

5.1.1 Current Measurement (act)

The value (act) of the last measurement is transmitted when the current measurement value is requested in accordance with the specified sampling rate. Each measurement is stored in a circular buffer for the subsequent calculation of minimum, maximum and average values.

5.1.2 Minimum and Maximum Values

The corresponding minimum (min) and maximum (max) values are calculated using data in the circular buffer for the specified interval (1 – 10 minutes). These values are then transmitted.

In the case of wind direction, the minimum/maximum values indicate the direction at which the minimum/maximum wind speed was measured.

5.1.3 Average Value

The average (avg) value calculated using data in the circular buffer for the specified interval (1 – 10 minutes) and transmitted. Moving averages can also be calculated this way.

For some values, the standard deviation is calculated for the same interval. The calculation of standard deviation will only be activated after the related UMB channel has been requested for the first time.

5.1.4 Vectorial Average Value (vct)

Wind measurements are calculated as vectors. The average values of the vectors (vct) are generated internally. This allows a value to be calculated for the magnitude (wind speed) and the angle (wind direction) of the calculated vector.

The calculation interval for the minimum, maximum and average values is set at 10 minutes. If necessary, this can be adjusted.

The evaluation of the standard deviation values is deactivated after power-on of the weather station. The function will be activated with the first request to any of the standard deviation channels.

To get standard deviation values of the first integration period after power-on, a dummy request to any one of the standard deviation channels should be inserted.

5.2 Air And Dew Point Temperature

Sampling rate: 1 minute

Generation of average value: 1 – 10 minutes

Units: °C; °F

UMB Channel				Measurement Variable (float 32)	Measuring Range		
act	min	max	avg		min	max	Unit
100	120	140	160	Air Temperature	-50.0	60.0	°C
105	125	145	165	Air Temperature	-58.0	140.0	°F
110	130	150	170	Dew Point Temperature	-50.0	60.0	°C
115	135	155	175	Dew Point Temperature	-58.0	140.0	°F

5.3 Wind Chill Temperature

Sampling rate: 1 minute, computed on base of the average temperature and average wind speed

Units: °C; °F

UMB Channel				Measurement Variable (float 32)	Measuring Range		
act	min	max	avg		min	max	Unit
111				Wind Chill Temperature	-60.0	70.0	°C
116				Wind Chill Temperature	-76.0	158.0	°F

5.4 Humidity

Sampling rate: 1 minute

Generation of average value: 1 – 10 minutes

Units %RH; g/m³; g/kg

UMB Channel				Measurement Variable (float 32)	Measuring Range		
act	min	max	avg		min	max	Unit
200	220	240	260	Relative Humidity	0.0	100.0	%
205	225	245	265	Absolute Humidity	0.0	1000.0	g/m ³
210	230	250	270	Mixing Ratio	0.0	1000.0	g/kg

5.5 Air Pressure

Sampling rate: 1 minute

Generation of average value: 1 – 10 minutes

Unit: hPa

UMB Channel				Measurement Variable (float 32)	Measuring Range		
act	min	max	avg		min	max	Unit
300	320	340	360	Absolute Air Pressure	300	1200	hPa
305	325	345	365	Relative Air Pressure	300	1200	hPa



NOTE

Height of the weather station above mean sea level must be provided in order for the relative air pressure to be calculated correctly. The factory setting is 0 m. This is done automatically by an AWOS where the height of the weather station above mean sea level is entered in the AWOS configuration. See for ...

5.6 Wet Bulb Temperature

Sampling rate: 1 minute

Generation of average value: 1 – 10 minutes

Units: °C; °F

UMB Channel				Measurement Variable (float 32)	Measuring Range		
act	min	max	avg		min	max	Unit
114				Wet Bulb Temperature	-50.0	60.0	°C
119				Wet Bulb Temperature	-58.0	140.0	°F

5.7 Wind Speed

The second measurements are averaged over 10 seconds for the output of the current (act) measurement. The *fast* channels deliver a value every second.

Sampling rate: 10 seconds

Generation of average value: 1 – 10 minutes

Generation of maximum value: 1 – 10 minutes based on the internal second measurements

Units: m/s; km/h; mph; kts

Response threshold: 0.3 m/s

UMB Channel					Measurement Variable (float 32)	Measuring Range		
act	min	max	avg	vct		min	max	Unit
400	420	440	460	480	Wind Speed	0	75.0	m/s
405	425	445	465	485	Wind Speed	0	270.0	km/h
410	430	450	470	490	Wind Speed	0	167.8	mph
415	435	455	475	495	Wind Speed	0	145.8	kts
401					Wind Speed Fast	0	75.0	m/s
406					Wind Speed Fast	0	270.0	km/h
411					Wind Speed Fast	0	167.8	mph
416					Wind Speed Fast	0	145.8	kts
403					Wind Speed Standard Deviation*	0	75.0	m/s
413					Wind Speed Standard Deviation*	0	167.8	mph

* The evaluation of the standard deviation values will be activated after the first request of a standard deviation channel.

5.8 Wind Direction

The second measurements are averaged over 10 seconds for the output of the current (act) measurement. The fast channels deliver a value every second.

The minimum/maximum wind direction indicates the direction at which the minimum/maximum wind speed was measured.

The corrected wind direction is calculated from the wind direction measured by the wind sensor and the heading measured by the compass.

Optionally the compass correction of the wind direction can be activated for all wind direction values.

The correction function is designed to correct the wind direction of a statically mounted weather station. If the alignment of the weather station changes during the measurement (for example, if the weather station is mounted on a rotating platform), the correction function will not work properly in all cases, especially for the vector average.

It is of course possible to use the correction function for mobile measurement units, where the alignment is changed between measurement periods.

Sampling rate: 10 seconds

Generation of average value: 1 – 10 minutes

Generation of maximum value: 1 – 10 minutes based on the internal second measurements

Unit: degrees

Response threshold: 0.3 m/s

UMB Channel				Measurement Variable (float 32)	Measuring Range		
act	min	max	avg		min	max	Unit
500	520	540	580	Wind Direction	0	359.9	°
501				Wind Direction Fast	0	359.9	°
502				Wind Direction Corrected	0	359.9	°
503				Wind Direction Standard Deviation*	0	359.9	°

* The evaluation of the standard deviation values will be activated after the first request of a standard deviation channel.

5.9 Wind Measurement Quality

The value is updated every 10 seconds and transmits the minimum wind measurement quality for the last 10 second interval. The fast value indicates the measurement quality of the one second measurement value.

This quality value allows the user to assess how well the measurement system is functioning in the respective ambient conditions. In normal circumstances, the value is 90 –100%. Values up to 50% do not represent a general problem. If the value falls towards zero, the measuring system is reaching its limits.

If the system is no longer able to conduct reliable measurements during critical ambient conditions, the error value 55h (85d) is transmitted (device unable to execute valid measurement due to ambient conditions).

Sampling

rate: 10 seconds

Unit: %

UMB Channel					Measurement Variable (float 32)	Measuring Range		
act	min	max	avg	vct		min	max	Unit
805					Wind Value Quality	0	100	%
806					Wind Value Quality (fast)	0	100	%

5.10 Compass

Reliable operation of the compass is only possible if the weather station has been mounted according to the instructions in this manual, i.e., on top of a mast. Should the weather station be mounted on a traverse, the distribution of iron mass will be different from the situation during factory calibration. This may lead to additional deviation of the bearing. This also applies to lightning rods mounted at the top of the mast.

Declination must also be taken into account in order to establish true north. The declination can be added to the weather station using calibration software.

When the aspirator fan is not rotating, the compass measurement value will be influenced by the magnetic field of the fan. Normally the compass measurement will be performed with the fan rotating to compensate for this influence. Otherwise, the deviation from the fan must be determined and taken into consideration.

Sampling rate: 5 minutes

Unit: degrees

UMB Channel					Measurement Variable (float 32)	Measuring Range		
act	min	max	avg	vct		min	max	Unit
510					Compass Heading	0	359	°

5.11 Precipitation Quantity — Absolute

This measurement reports the accumulated precipitation since the last reboot. The measurement is retained for the duration of a short power failure. To reset this value, use the software configuration or disconnect the weather station from the power supply for at least one hour.

Sampling rate: Event-dependent on reaching the response threshold

Response threshold: 0.01 mm

Units: L/m²; mm; in; mil

UMB Channel	Measurement Variable (float 32)	Unit
600	Precipitation Quantity — Absolute	L/m ²
620	Precipitation Quantity — Absolute	mm
640	Precipitation Quantity — Absolute	in
660	Precipitation Quantity — Absolute	mil

5.12 Precipitation Quantity — Differential

Each request from a differential channel sets the accumulated quantity back to zero. If the response from the device is lost due to a transmission error, the quantity accumulated to date is also lost. The quantity accumulated to date is also reset each time the equipment is rebooted.

Sampling rate: Event-dependent on reaching the response threshold

Response threshold: 0.01 mm

Units: L/m²; mm; in; mil

UMB Channel	Measurement Variable (float 32)	Unit
605	Precipitation Quantity — Differential	L/m ²
625	Precipitation Quantity — Differential	mm
645	Precipitation Quantity — Differential	in
665	Precipitation Quantity — Differential	mil

5.13 Precipitation Intensity

Precipitation intensity is always calculated on the basis of the precipitation measured during the previous minute.

Sampling rate: 1 minute

Response threshold: 0.6 mm/h

Units: (L/m²)/h; mm/h; in/h; mil/h

UMB Channel	Measurement Variable (float 32)	Measuring Range		
		min	max	Unit
800	Precipitation Intensity	0	200.0	(L/m ²)/h
820	Precipitation Intensity	0	200.0	mm/h
840	Precipitation Intensity	0	7.874	in/h
860	Precipitation Intensity	0	7.874	Mil/h

5.14 Precipitation Type

A detected precipitation type remains valid for 2 minutes after the end of the precipitation event. In order to record precipitation types that only occur for a short period (e.g., short-term rain), the request interval should be 1 minute or shorter. Ice, hail and sleet are reported as rain (60).

Sampling rate: Event-dependent on reaching the response threshold

Response threshold: 0.002 mm

Follow-up time: 2 minutes

UMB Channel	Measurement Variable (uint8)	Coding
700	Precipitation Type	0 = No precipitation 40 = Unspecified precipitation 60 = Liquid precipitation (e.g., rain) 70 = Solid precipitation (e.g., snow)

5.15 Heating Temperatures

Sampling rate: 1 minute

Units: °C; °F

UMB Channel				Measurement Variable (float 32)	Measuring Range		
act	min	max	avg		min	max	Unit
112				Wind Sensor Heater Temperature	-50.0	150.0	°C
113				Precipitation Sensor Heater Temperature	-50.0	150.0	°C
117				Wind Sensor Heater Temperature	-58.0	302.0	°F
118				Precipitation Sensor Heater Temperature	-58.0	302.0	°F

5.16 Global Radiation

The average, maximum and minimum values are evaluated from the 1 minute averages of the 10-second spot value.

Sampling rate: 10 seconds

Generation of average value: 1 – 10 minutes

Unit: W/m²

UMB Channel				Measurement Variable (float 32)	Measuring Range		
act	min	max	avg		min	max	Unit
900				Global Radiation	0.0	1400.0	W/m ²

6. Configuration

The 9620 Series of Compact Weather Stations is delivered preconfigured and ready to use. The following default settings are programmed.

Class ID:	7 (cannot be modified)
Device ID:	1 (address 7001h = 28673d)
Baud rate:	19200 bps
RS-485 protocol:	Binary
Calculation interval:	10 measurements
Local altitude:	0 m above mean sea level

The Device ID needs to be changed only if more than one weather station will be used on a UMB bus.

The altitude above mean sea level must be configured if the weather station is used outside an AWOS where the value can be configured in the AWOS software.

The declination is not factory-programmed. Declination must be configured if the weather station is used outside an AWOS where the value can be configured in the AWOS software. Declination must be taken into consideration if the compass functionality is used to identify a north benchmark.

The UMB Configuration tool is used to configure the weather stations. The latest version of the UMB Configuration tool is available from the following site. Always use the latest version.

http://lufft.com/dateianzeige.php/?Dateiname=download/software/UMB_Config_V25.zip

The following list maps the 9620 Series of Compact Weather Stations to the sensor nomenclature used by the UMB Configuration tool.

Model	UMB Configuration Tool Name
9620	WS200-UMB
9621	WS300-UMB
9622	WS400-UMB
9623	WS500-UMB
9624	WS600-UMB
9625	WS301-UMB
9626	WS501-UMB

Consult [Universal Measurement Bus Communication Protocol for Meteorological Sensors](#) for information about the UMB protocol.

7. Maintenance

Once installed, the 9620 Series of Compact Weather Stations requires little maintenance.

Under normal circumstances, it is sufficient to perform the cleaning steps described below as part of the annual inspection. The cleaning may have to be performed more frequently in areas subject to windblown dust/sand, sea spray, or fog.

1. Inspect and clean the Model 9625 and 9626 pyranometer diffuser using a soft cloth and water.
2. Clean the ultrasonic transducers used for wind speed/direction measurements (Models 9620, 9623, 9624, 9626) using a soft cloth and water.

Avoid cleaning during the high heat and low humidity parts of a hot day to avoid leaving water streak marks when the water evaporates too quickly.

During the annual inspection, verify that the South and North ultrasonic transducers used for wind speed/direction measurements are aligned with the reference North benchmark as described in Section 3.3.

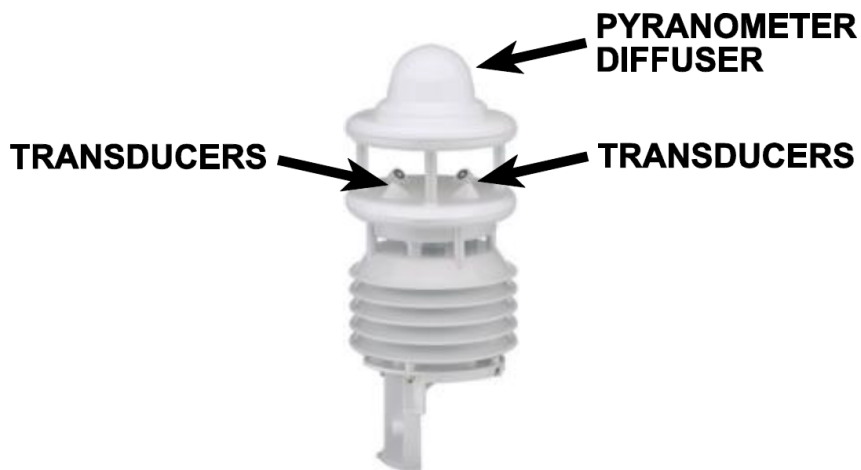

Figure 10. Locations of Pyranometer Diffuser and Wind Speed/Direction Transducers

There are no other recommended maintenance procedures. Please arrange for any faulty equipment to be checked and, if necessary, repaired by All Weather, Inc. Do not open the equipment and do not under any circumstances attempt to carry out your own repairs.

8. Troubleshooting

Problem	Possible Causes
Weather station does not allow polling/ does not respond	<ul style="list-style-type: none"> • Check power supply • Check interface connection
Weather station reports precipitation when it is not raining	<ul style="list-style-type: none"> • Check that the weather station was installed correctly
The measured temperature appears too high/measured humidity appears too low	<ul style="list-style-type: none"> • Check the operation of the aspirator fan
Wind direction values are incorrect	<ul style="list-style-type: none"> • Weather station is not correctly aligned — check that the weather station is aligned to the North
The quality of the wind measurement is not always 100%	<ul style="list-style-type: none"> • In normal operation the weather station should always transmit 90 – 100%. Values up to 50% do not represent a general problem. • When the error value 55h (85d) is transmitted, this value is 0%. • If the weather station always transmits values below 50%, this may mean that there is a fault.
Weather station transmits error value 24h (36d)	<ul style="list-style-type: none"> • A channel is being polled that is not available on this model
Weather station transmits error value 28h (40d)	<ul style="list-style-type: none"> • The weather station is in the initialization phase following startup — the weather station will deliver measurements after approx. 10 seconds
Weather station transmits error value 50h (80d)	<ul style="list-style-type: none"> • The weather station is being operated above the limit of the specified measuring range
Weather station transmits error value 51h (81d)	<ul style="list-style-type: none"> • The weather station is being operated below the limit of the specified measuring range
Weather station transmits error value 55h (85d) during wind measurement	<p>The weather station is unable to execute a valid measurement because of ambient conditions.</p> <p>This may be happen for the following reasons:</p> <ul style="list-style-type: none"> • The weather station is being operated well above the limit of the specified measuring range • Very strong horizontal rain or snow • The ultrasonic transducers are very dirty — clean the transducers • The ultrasonic transducers are iced over — check that heating mode is on and check the heating connection • There are foreign objects within the measuring section of the ultrasonic transducers • One of the ultrasonic transducers is faulty — return the weather station to All Weather, Inc. for repair
Weather station transmits an error value not listed	<ul style="list-style-type: none"> • Contact ADB Safegate.

9. Specifications

Parameter	Specification
Air Temperature	
Measurement Principle	NTC thermistor
Measurement Range	-50°C to +60°C
Resolution	0.1°C (-20°C to+50°C), otherwise 0.2°C
Accuracy	±0.2°C (-20°C to+50°C), otherwise ±0.5°C (> -30°C)
Relative Humidity	
Measurement Principle	Capacitive
Measurement Range	0—100%
Resolution	0.1%
Accuracy	±2%
Air Pressure	
Measurement Principle	MEMS (capacitive)
Measurement Range	300–1200 hPa
Resolution	0.1 hPa
Accuracy	±0.5 hPa (0°C to+40°C),
Wind Speed	
Measurement Principle	Ultrasonic
Measurement Range	0–75 m/s
Resolution	0.1 m/s
Accuracy	±0.3 m/s or ±3% (0 to 35 m/s) ±5% (>35 m/s)
Response Threshold	0.3 m/s
Wind Direction	
Measurement Principle	Ultrasonic
Measurement Range	0–359.9°
Resolution	0.1 m/s
Accuracy	<3° (>1 m/s RMSE)
Response Threshold	0.3 m/s
Compass	
Measurement Principle	Integrated electronic compass
Measurement Range	0–359°
Resolution	1.0°
Accuracy	±10%

Parameter	Specification
Precipitation	
Measurement Principle	Doppler radar
Measurement Range (drop size)	0.3–5.0 mm
Liquid Precipitation Resolution	0.01 mm
Precipitation Types	Rain, snow
Repeatability	>90%
Response Threshold	0.002 mm
Precipitation Intensity	0–200 mm/h (sampling rate 1 min)
Global Radiation	
Measurement Principle	Thermopile pyranometer
Measurement Range	0.0–1400.0 W/m ²
Resolution	<1 W/m ²
Response Time (95%)	18 s
Non-stability (change/year)	<1%
Non-linearity (0 to 1000 W/m ²)	<1%
Directional Response	0.1 m/s
(up to 80° with 1000 W/ m ² beam)	<20 W/m ²
Temperature Dependence of Sensitivity	<5% (-10 to +40°C)
Tilt Error (at 1000 W/m ²)	<1%
Spectral Range	300–2800 nm
Environmental	
Operating Temperature	-50 to +60°C
Storage Temperature	-50 to +70°C
Relative Humidity	0–100%, noncondensing
Accuracy	±10%
Serial Data	
Serial Output	RS-485 (half duplex)
Baud Rate	1200, 2400, 4800, 9600, 14400, 192003, 28800, 57600 bps
Serial Port Parameter Setting	8-N-1 (8 data bits, no parity, 1 stop bit)
Power Requirements	
Supply Voltage	24 V DC @ up to 160 mA
Heating	24 V DC @ up to 1.7 A

9620 Series Compact Weather Stations

Parameter	Specification
Mechanical	
Housing	Plastic
Ingress Protection Rating	IP66
Mounting	Crossarm

Parameter	Measuring Range						
	9620	9621	9622	9623	9624	9625	9626
Dimensions	155 mm diameter × 194 mm H	155 mm diameter × 223 mm H	155 mm diameter × 279 mm H	155 mm diameter × 287 mm H	155 mm diameter × 343 mm H	155 mm diameter × 268 mm H	155 mm diameter × 332 mm H
Weight	0.8 kg	1.0 kg	1.3 kg	1.2 kg	1.5 kg	1.3 kg	1.5 kg

10. Warranty

Any defect in design, materials, or workmanship which may occur during proper and normal use during a period of 1 year from date of installation or a maximum of 2 years from shipment will be corrected by repair or replacement by ADB Safegate

Optimizing Airside Operations From approach to take-off

SMARTER. BETTER. **NOW.**

**ADB
SAFEGATE**
www.adbsafegate.com