



L-854 Radio Control Equipment

RCE, Type I, Style A

User Manual

96A0390, Rev. v2.4.0, 2026-03-11

**ADB
SAFEGATE**

A.0 Disclaimer / Standard Warranty

CE certification

The equipment listed as CE certified means that the product complies with the essential requirements concerning safety and hygiene. The European directives that have been taken into consideration in the design are available on written request to ADB SAFEGATE.

ETL certification

The equipment listed as ETL certified means that the product complies with the essential requirements concerning safety and C22.2 No.180:13 (R2018) regulations. The CSA directives that have been taken into consideration in the design are available on written request to ADB SAFEGATE.

All Products Guarantee

ADB SAFEGATE will correct by repair or replacement per the applicable guarantee below, at its option, equipment or parts which fail because of mechanical, electrical or physical defects, provided that the goods have been properly handled and stored prior to installation, properly installed and properly operated after installation, and provided further that Buyer gives ADB SAFEGATE written notice of such defects after delivery of the goods to Buyer. Refer to the Safety section for more information on Material Handling Precautions and Storage precautions that must be followed.

ADB SAFEGATE reserves the right to examine goods upon which a claim is made. Said goods must be presented in the same condition as when the defect therein was discovered. ADB SAFEGATE further reserves the right to require the return of such goods to establish any claim.

ADB SAFEGATE's obligation under this guarantee is limited to making repair or replacement within a reasonable time after receipt of such written notice and does not include any other costs such as the cost of removal of defective part, installation of repaired product, labor or consequential damages of any kind, the exclusive remedy being to require such new parts to be furnished.

ADB SAFEGATE's liability under no circumstances will exceed the contract price of goods claimed to be defective. Any returns under this guarantee are to be on a transportation charges prepaid basis. For products not manufactured by, but sold by ADB SAFEGATE, warranty is limited to that extended by the original manufacturer. This is ADB SAFEGATE's sole guarantee and warranty with respect to the goods; there are no express warranties or warranties of fitness for any particular purpose or any implied warranties of fitness for any particular purpose or any implied warranties other than those made expressly herein. All such warranties being expressly disclaimed.

Standard Products Guarantee

Products manufactured by ADB SAFEGATE are guaranteed against mechanical, electrical, and physical defects (excluding lamps) which may occur during proper and normal use for a period of two years from the date of ex-works delivery, and are guaranteed to be merchantable and fit for the ordinary purposes for which such products are made.



Note

See your applicable sales agreement for a complete warranty description.

Replaced or repaired equipment under warranty falls into the warranty of the original delivery. No new warranty period is started for these replaced or repaired products.

FAA Certified products manufactured by ADB SAFEGATE

ADB SAFEGATE L858 Airfield Guidance Signs are warranted against mechanical and physical defects in design or manufacture for a period of 2 years from date of installation, per FAA AC 150/5345-44 (applicable edition).

ADB SAFEGATE LED products (with the exception of obstruction lighting) are warranted against electrical defects in design or manufacture of the LED or LED specific circuitry for a period of 4 years from date of installation, per FAA EB67 (applicable edition). These FAA certified constant current (series) powered LED products must be installed, interfaced and powered with and through products certified under the FAA Airfield Lighting Equipment Program (ALECP) to be included in this 4 (four) year warranty. This includes, but is not limited to, interface with products such as Base Cans, Isolation Transformers, Connectors, Wiring, and Constant Current Regulators.



Note

See your sales order contract for a complete warranty description.

Replaced or repaired equipment under warranty falls into the warranty of the original delivery. No new warranty period is started for these replaced or repaired products.

Liability



WARNING

Use of the equipment in ways other than described in the catalog leaflet and the manual may result in personal injury, death, or property and equipment damage. Use this equipment only as described in the manual.

ADB SAFEGATE cannot be held responsible for injuries or damages resulting from non-standard, unintended uses of its equipment. The equipment is designed and intended only for the purpose described in the manual. Uses not described in the manual are considered unintended uses and may result in serious personal injury, death or property damage.

Unintended uses, includes the following actions:

- Making changes to equipment that have not been recommended or described in this manual or using parts that are not genuine ADB SAFEGATE replacement parts or accessories.
- Failing to make sure that auxiliary equipment complies with approval agency requirements, local codes, and all applicable safety standards if not in contradiction with the general rules.
- Using materials or auxiliary equipment that are inappropriate or incompatible with your ADB SAFEGATE equipment.
- Allowing unskilled personnel to perform any task on or with the equipment.

Copyright Statement

This manual or parts thereof may not be reproduced, stored in a retrieval system, or transmitted, in any form or by any means, electronic, mechanical, photocopying, recording, nor otherwise, without the author's prior written consent.

This manual could contain technical inaccuracies or typographical errors. The author reserves the right to revise this manual from time to time in the contents thereof without obligation of the author to notify any person of such revision or change. Details and values given in this manual are average values and have been compiled with care. They are not binding, however, and the author disclaims any liability for damages or detriments suffered as a result of reliance on the information given herein or the use of products, processes or equipment to which this manual refers. No warranty is made that the use of the information or of the products, processes or equipment to which this manual refers will not infringe any third party's patents or rights. The information given does not release the buyer from making their own experiments and tests.

Table of Contents

1.0 Safety	1
1.1 Safety Messages.....	1
1.1.1 Introduction to Safety.....	2
1.1.2 Intended Use.....	2
1.1.3 Material Handling Precautions: Storage.....	3
1.1.4 Operation Safety.....	3
1.1.5 Maintenance Safety.....	3
1.1.6 Material Handling Precautions, ESD.....	4
2.0 L-854 Radio Control Equipment	5
2.1 About this manual.....	5
2.1.1 How to work with the manual.....	5
2.2 Introduction.....	5
2.3 Digital Radio Control.....	6
2.3.1 FCC Part 15 Notice.....	7
3.0 Options	9
3.1 Equipment Specification Data.....	9
3.2 Radio Control Restrictions.....	9
3.3 Interfacing the Radio Controller.....	10
3.4 Intensity Control.....	10
4.0 Theory of Operation	11
4.1 General.....	11
4.2 Terminal Block.....	11
4.3 Control Board.....	12
4.4 Power Supply Board.....	13
4.5 Relay Board.....	14
5.0 Installation	17
5.1 Unpacking.....	17
5.2 Installing L-854 Radio Control Equipment.....	17
5.2.1 Remote Antenna (Option).....	19
5.2.2 Safety Precautions.....	20
5.2.3 Mounting Remote Antenna.....	20
6.0 Operation	21
6.1 Controls and Indicators.....	22
6.2 Startup Procedures.....	23
7.0 Maintenance	25
7.1 Introduction.....	25
7.2 Receiver Frequency Setting.....	25
8.0 Troubleshooting	27
8.1 Wiring Schematics.....	29
8.1.1 Introduction.....	29
8.1.2 Wiring Diagram List.....	29
9.0 Parts	37
9.1 Ordering Code.....	37
9.2 Ordering Code.....	0
9.3 Parts Diagrams.....	38
9.4 Spare Parts.....	39
A.0 Support	41
A.1 ADB SAFEGATE Website.....	42
A.2 Recycling.....	43
A.2.1 Local Authority Recycling.....	43
A.2.2 ADB SAFEGATE Recycling.....	43

List of Figures

Figure 1: L-854 Radio Control Equipment	6
Figure 2: L-854 Main Assembly	11
Figure 3: Control Board 44A6748	12
Figure 4: Power Supply Board 44A6749	13
Figure 5: Relay Board 44A7647	14
Figure 6: Mounting Dimensions	18
Figure 7: Radio Control Equipment Controls and Indicators	21
Figure 8: 120 VAC Unit, Internal Wiring Diagram	30
Figure 9: 120 VAC Unit, 40A Relay Option	31
Figure 10: 240 VAC Unit, Internal Wiring Diagram	32
Figure 11: 240 VAC Unit, 40A Relay Option	33
Figure 12: 48 DC Unit, Internal Wiring Diagram	34
Figure 13: 12 DC Unit, Internal Wiring Diagram	35
Figure 14: RCE Display View	38
Figure 15: RCE Interior Views	39

List of Tables

Table 1: Supplied Equipment	9
Table 2: Required Equipment Not Supplied	9
Table 3: Interface of Radio Control with Airport Visual Aids	10
Table 4: Terminal Strip Interface	11
Table 5: Power Supply Fuse Layout	13
Table 6: Cumulative (Incremental) Operation	14
Table 7: Individual Operation	15
Table 8: Radio Control Configuration Switch	15
Table 9: Relay Board Fuse Layout	15
Table 10: Controls and Indicators	22
Table 11: L-854 Radio Control Equipment Error Codes	27
Table 12: L-854 Radio Control Equipment Warning Codes	27
Table 13: L-854 Radio Control Equipment Troubleshooting	28
Table 14: Spare Parts	40

1.0 Safety

Introduction to Safety







This section contains general safety instructions for installing and using ADB SAFEGATE equipment. Some safety instructions may not apply to the equipment in this manual. Task- and equipment-specific warnings are included in other sections of this manual where appropriate.

1.1 Safety Messages

HAZARD Icons used in this manual

For all HAZARD symbols in use, see the Safety section. All symbols must comply with ISO and ANSI standards.

Carefully read and observe all safety instructions in this manual, which alert you to safety hazards and conditions that may result in personal injury, death or property and equipment damage and are accompanied by the symbols shown below.

	<p>WARNING Failure to observe a warning may result in personal injury, death or equipment damage.</p>
	<p>DANGER – Risk of electrical shock or ARC FLASH Disconnect equipment from line voltage. Failure to observe this warning may result in personal injury, death, or equipment damage. ARC Flash may cause blindness, severe burns or death.</p>
	<p>WARNING – Wear personal protective equipment Failure to observe may result in serious injury.</p>
	<p>WARNING – Do not touch Failure to observe this warning may result in personal injury, death, or equipment damage.</p>
	<p>CAUTION Failure to observe a caution may result in equipment damage.</p>
	<p>ELECTROSTATIC SENSITIVE DEVICES This equipment may contain electrostatic devices.</p>

Qualified Personnel

	<p>Important Information The term qualified personnel is defined here as individuals who thoroughly understand the equipment and its safe operation, maintenance and repair. Qualified personnel are physically capable of performing the required tasks, familiar with all relevant safety rules and regulations and have been trained to safely install, operate, maintain and repair the equipment. It is the responsibility of the company operating this equipment to ensure that its personnel meet these requirements. Always use required personal protective equipment (PPE) and follow safe electrical work practice.</p>
---	--

1.1.1 Introduction to Safety



CAUTION

Unsafe Equipment Use

This equipment may contain electrostatic devices, hazardous voltages and sharp edges on components

- Read installation instructions in their entirety before starting installation.
- Become familiar with the general safety instructions in this section of the manual before installing, operating, maintaining or repairing this equipment.
- Read and carefully follow the instructions throughout this manual for performing specific tasks and working with specific equipment.
- Make this manual available to personnel installing, operating, maintaining or repairing this equipment.
- Follow all applicable safety procedures required by your company, industry standards and government or other regulatory agencies.
- Install all electrical connections to local code.
- Use only electrical wire of sufficient gauge and insulation to handle the rated current demand. All wiring must meet local codes.
- Route electrical wiring along a protected path. Make sure they will not be damaged by moving equipment.
- Protect components from damage, wear, and harsh environment conditions.
- Allow ample room for maintenance, panel accessibility, and cover removal.
- Protect equipment with safety devices as specified by applicable safety regulations
- If safety devices must be removed for installation, install them immediately after the work is completed and check them for proper functioning prior to returning power to the circuit.

Failure to follow these instructions can result in serious injury, death or equipment damage

Additional Reference Materials



Important Information

- IEC – International Standards and Conformity Assessment for all electrical, electronic and related technologies.
- IEC 60364 – Electrical Installations in Buildings.
- CSA – C22.2 No.180:13 (R2018), series isolating transformers for airport lighting.
- FAA Advisory: AC 150/5340-26 (current edition), Maintenance of Airport Visual Aid Facilities.
- Maintenance personnel must refer to the maintenance procedure described in the ICAO Airport Services Manual, Part 9.
- ANSI/NFPA 79, Electrical Standards for Metalworking Machine Tools.
- National and local electrical codes and standards.

1.1.2 Intended Use



CAUTION

Use this equipment as intended by the manufacturer.

This equipment is designed to perform a specific function. Do not use this equipment for other purposes.

Failure to follow this instruction can result in serious injury, death or equipment damage.

1.1.3 Material Handling Precautions: Storage



CAUTION

Improper Storage

Store this equipment properly

- If equipment is to be stored prior to installation, it must be protected from the weather elements and kept free of condensation and dust.

Failure to follow this instruction can result in equipment damage

1.1.4 Operation Safety



CAUTION

Improper Operation

Do Not Operate this equipment other than as specified by the manufacturer

- Only qualified personnel, physically capable of operating the equipment and with no impairments in their judgment or reaction times, should operate this equipment.
- Read all system component manuals before operating this equipment. A thorough understanding of system components and their operation will help you operate the system safely and efficiently.
- Before starting this equipment, check all safety interlocks, fire-detection systems, and protective devices such as panels and covers. Make sure all devices are fully functional. Do not operate the system if these devices are not working properly. Do not deactivate or bypass automatic safety interlocks or locked-out electrical disconnects or pneumatic valves.
- Protect equipment with safety devices as specified by applicable safety regulations.
- If safety devices must be removed for installation, install them immediately after the work is completed and check them for proper functioning.
- Route electrical wiring along a protected path. Make sure they will not be damaged by moving equipment.
- Never operate equipment with a known malfunction.
- Do not attempt to operate or service electrical equipment if standing water is present.
- Use this equipment only in the environments for which it is rated. Do not operate this equipment in humid, flammable, or explosive environments unless it has been rated for safe operation in these environments.
- Never touch exposed electrical connections on equipment while the power is ON.

Failure to follow these instructions can result in serious injury, death or equipment damage.

1.1.5 Maintenance Safety



DANGER

ELECTRIC SHOCK HAZARD

THIS EQUIPMENT MAY CONTAIN ELECTROSTATIC DEVICES

- DO NOT OPERATE A SYSTEM THAT CONTAINS MALFUNCTIONING COMPONENTS. IF A COMPONENT MALFUNCTIONS, TURN THE SYSTEM OFF IMMEDIATELY.
- DISCONNECT AND LOCK OUT ELECTRICAL POWER.
- ALLOW ONLY QUALIFIED PERSONNEL TO MAKE REPAIRS OR REPLACE MALFUNCTIONING COMPONENTS ACCORDING TO INSTRUCTIONS PROVIDED IN MANUAL.

FAILURE TO FOLLOW THESE INSTRUCTIONS CAN RESULT IN DEATH OR EQUIPMENT DAMAGE

1.1.6 Material Handling Precautions, ESD



CAUTION

Electrostatic Sensitive Devices

This equipment may contain electrostatic devices

- Protect from electrostatic discharge.
- Electronic modules and components should be touched only when this is unavoidable e.g. soldering, replacement.
- Before touching any component of the cabinet you shall bring your body to the same potential as the cabinet by touching a conductive earthed part of the cabinet.
- Electronic modules or components must not be brought in contact with highly insulating materials such as plastic sheets, synthetic fiber clothing. They must be laid down on conductive surfaces.
- The tip of the soldering iron must be grounded.
- Electronic modules and components must be stored and transported in conductive packing.

Failure to follow this instruction can result in equipment damage

2.0 L-854 Radio Control Equipment

Type I, Style A.

L-854 RCE Digital Radio Control, Air-to-ground (Type I) radio control

The ETL-Certified RCE provides unattended, all-weather, air-to-ground radio control of airport lighting systems. Simple to install, the radio controller allows the frequency (from 118.0 to 136.0MHz VHF — tunable in 25 KHz increments) to be programmed by the user. The controller is also flexible with an input power of 120 or 240V AC, ± 10 percent, 50/60Hz or 12-48V DC, ± 20 percent, and two independent sets of output relays that can be programmed for either individual or incremental operation. The controller also has a built-in speaker with volume control and a whip or remote antenna. For Canadian applications, the L-854 is configurable as a Type J or Type K ARCAL unit via DIP switch selection.



2.1 About this manual

The manual shows the information necessary to:

- Program and Configure L-854 Radio Control Equipment.

2.1.1 How to work with the manual

1. Become familiar with the structure and content.
2. Carry out the actions completely and in the given sequence.

2.2 Introduction

L-854 Radio Control Equipment

See [Figure 1](#) L-854 Radio Control Equipment.

This section describes the L-854 Type I Radio Control system.

Figure 1: L-854 Radio Control Equipment



The L-854 Type I Radio Control system is used for air-to-ground control of airport lighting facilities. This equipment is manufactured to FAA specification AC 150/5345-49.

The L-854 Radio Control, consisting of an AM receiver and a Style A decoder, is a completely self-contained system for controlling lighting functions on an airport from a remote radio transmitter. The transmitter is usually the communications transmitter in an aircraft.

The Radio Control has two sets of three output relays operated by keying the transmitter in specific sequences. Either set of relays can operate in either a cumulative fashion, or in single output mode, where only one relay in the set is on at a time. To power these relays, pilots can set their communications transmitters to the frequency to which the L-854 is tuned.

Three clicks of the mike button within five seconds powers the lighting system on the low (10) brightness setting. Five clicks of the mike button within five seconds powers the lighting system on the medium (30) brightness setting. Seven clicks of the mike button within five seconds powers the lighting system on the high (100) brightness setting. The L-854 Radio Control can be field programmed for three, five, and seven clicks to change the light settings.

The contacts of the relays in the L-854 are for control purposes only. They are rated 3 amps (inductive) and are capable of operating the coils or power relays. They are not intended to switch lighting-load currents.

2.3 Digital Radio Control

Compliance with Standards

FAA	L-854 AC 150/5345-49 (Current Edition). ETL Certified.
ICAO	Aerodrome Design Manual, Part 5 para. 3.4.6.(25 KHz only)
FCC	47 CFR, Part 15:2007 (Class A).
T/C	Transport Canada TP 312 - Aerodromes Standards and Recommended Practices.

Uses

FAA L-854, ICAO, FCC & TP 312

Provides air-to-ground (Type I) radio control of airport lighting systems.

Application

The primary function of the L-854 Radio Controller is to allow maximum utilization of airport runway lighting systems during times when the airport is unattended.

Runway or approach lighting systems may be activated and intensity controlled remotely by using the L-854 Radio Controller. This is accomplished by the simple process of keying the microphone button of the regular VHF communication transmitter in the approaching aircraft. No special airborne equipment or adapters are required. Two independent sets of output relays can be programmed for either individual or incremental operation.

The lights are activated remotely from the air and remain on for a period of 15 minutes and turn off automatically thereafter. Additional timer settings of 1, 30, 45 and 60 minutes are available. Selectable re-command enable/disable prevents setting outputs to a different state until the L-854 has timed out.

Selectable decoder enable/disable prevents multiple relay operation during the daytime when ATC normally controls the lights.

Runway edge lighting, MALSR, or REILs are prime candidates for radio control operation.

In Canada, ARCAL systems are generally available in two forms. Type J allows connected systems to be activated at a single intensity. Type K allows three selections of connected systems and are generally used to scale the light intensity selection on connected high and medium intensity lights.

Electrical

The Receiver is a single-conversion super-heterodyne design operating at a nominal radio frequency within the VHF band 118 to 136 MHz. The sensitivity is adjustable from 1 to 30 microvolts as desired by the user, permitting a control range of 1 to 20 miles. The receiver is adjustable in steps of 25.0 KHz (0.025 MHz) between 118.0 and 136.0 MHz VHF. The Unic ,kom channel, 122.8 MHz, is a frequent choice. Decoding is accomplished by solid-state digital circuitry, which is designed to sense the presence of three, five, or seven pulses within a five-second time period. The digital circuitry determines if any of these conditions exist and affect proper output relay closures. The L-854 Radio Control Equipment complies with FCC Part 15 rules and regulations.

Input Power Requirements

Voltage	Maximum VA
12 VDC	11 ¹
48 VDC	13
120 VAC	15 ²
240 VAC	18 ²

2.3.1 FCC Part 15 Notice

This device complies with Part 15 of the FCC Rules. Operation is subject to the following two conditions:

1. This device may not cause harmful interference, and
2. This device must accept any interference received, including interference that may cause undesired operation.

¹Typical standby power is 4 VA at 12 VDC for calculating solar power autonomy

²The optional 40 A relay will add 10 VA when energized

3.0 Options

Options are available for the L-854 Radio Control Equipment: radio controller power handling capability and operation as a Canadian Mode J controller.

Radio Controller Power Handling Capability

An optional 40 amp relay (53A0432) is available, for the operation of airfield lighting or other devices in a single step configuration.

Canada Mode J and K Operation

The Radio Control system will operate in Canada as a Mode K controller with no additional modification. It will also operate as a Mode J controller by placing switch position 3 of SW1 on the Relay Board into the ON position. Reference [Table 8](#). This will allow a single intensity level to be set with five clicks.

3.1 Equipment Specification Data

[Table 1](#) lists supplied equipment and accessories.

Table 1: Supplied Equipment

Quantity	Description
1	L-854 Radio Control Equipment
1	Remote Antenna Kit (includes antenna, and coaxial cable) (Option)
1	Instruction Manual 96A0390

[Table 2](#) lists items not supplied that might be required for installation.

Table 2: Required Equipment Not Supplied

Quantity	Description	Part Number
A/R	grounding rods	commercial
A/R	silicone rubber	Dow-Corning Silastic Rubber or G.E. Silicone Seal
1	antenna mast (Used with Remote Antenna option)	commercial
A/R	antenna mounting hardware (Used with Remote Antenna option)	commercial
1	Lightning Arrestor (Used with Remote Antenna option)	commercial
1	circuit breaker (size per installation plans)	commercial
4	1/4 x 1 in. long lag screws (for mounting enclosure)	commercial
4	1/4 in. flat washer for (1/4 x 1 in. long lag screws)	commercial
1	ground strap	commercial

3.2 Radio Control Restrictions

Use air-to-ground Radio Control at uncontrolled airports or at controlled airports during periods when the Air Traffic Control tower is closed. Except for obstruction lights and the airport beacon, all other lighting systems on the airport may be operated by air-to-ground Radio Control.

3.3 Interfacing the Radio Controller

You can directly connect the Radio Controller to the control interface of the airfield lighting power regulators, to an L-890 ALCMS system, or use a relay interface panel to provide additional switching capabilities or reduce the load on the Radio Controller. Configure the Radio Control system so the runway lights are on whenever the other lighting systems serving the runway are on, except during daytime operations.

Configure the Radio Control system with a day mode to power only those lighting systems that are useful during the day. This mode can be selected automatically by means of a photocell or by a manual switch. Using the day mode, however, means that the daytime IFR procedures associated with the deactivated lighting systems cannot be used.

In areas with heavy voice traffic on the Radio Controller frequency, there may be nuisance activation due to random microphone clicks. The Decoder Disable can be wired through the terminal block to an external switch, relay or external photocell. Placing a jumper or closed switch between terminals 1 and 3 of the terminal block will disable the decoder. See Table 4.

When the air-to-ground Radio Control is used at night, the lighting system may not be powered for long periods of time. The default setting for the controller is the recommended FAA time of 15 minutes. Other times of 30, 45 or 60 minutes can be selected from the front panel.

3.4 Intensity Control

Table 3 provides guidance on how to interface the Radio Control with the intensity settings of the airport lighting system. For example, connect a lighting system with five intensity settings so three clicks of the microphone would power brightness setting 1 or 2, five clicks would power setting 3, and seven clicks would power setting 5. The airport authority may select either setting 1 or 2 for the lowest brightness setting, depending on the background lighting at the airport.

Table 3: Interface of Radio Control with Airport Visual Aids

Lighting System	Number of Intensity Steps	Status During Idle Periods	Intensity Setting Selected per Number of Microphone Clicks		
			3 clicks	5 clicks	7 clicks
Approach Lights	2	Off	Low	Low	High
	3	Off	Low	Medium	High
	5	Off	1 or 2	3	5
Edge Lights: Low Intensity Med. Intensity High Intensity	1	Off	On	On	On
	3	Off or Low	Low	Medium	High
	5	Off or Low	1 or 2	3	5
Taxiway Edge Lights	1	Off	On	On	On
	2	Off	Low	Low	High
	3	Off	Low	Medium	High
Runway Centerline Touchdown Zone Lights	5	Off	1 or 2	3	5
Taxiway Centerline Lights	3	Off	Low	Medium	High
	5	Off	1 or 2	3	5
REILS	1	Off	Off	Off	On
	2	Off	Off	Low	High
	3	Off	Low	Medium	High
Visual Glideslope Systems	3	Off	On	On	On
	5	Off	Low	Medium	High



Note

Table 3 is from FAA AC 150/5340-30, Table 8-1.

4.0 Theory of Operation

This subsection describes the L-854 Radio Control Equipment theory of operation. Refer to [Figure 2](#).

4.1 General

The L-854 has three major components: the Radio Control Board (44A6748), the Radio Display Board (44A6746), the Radio Power Supply Board (44A6749), and the Radio Relay Board (44A6747).

Figure 2: L-854 Main Assembly

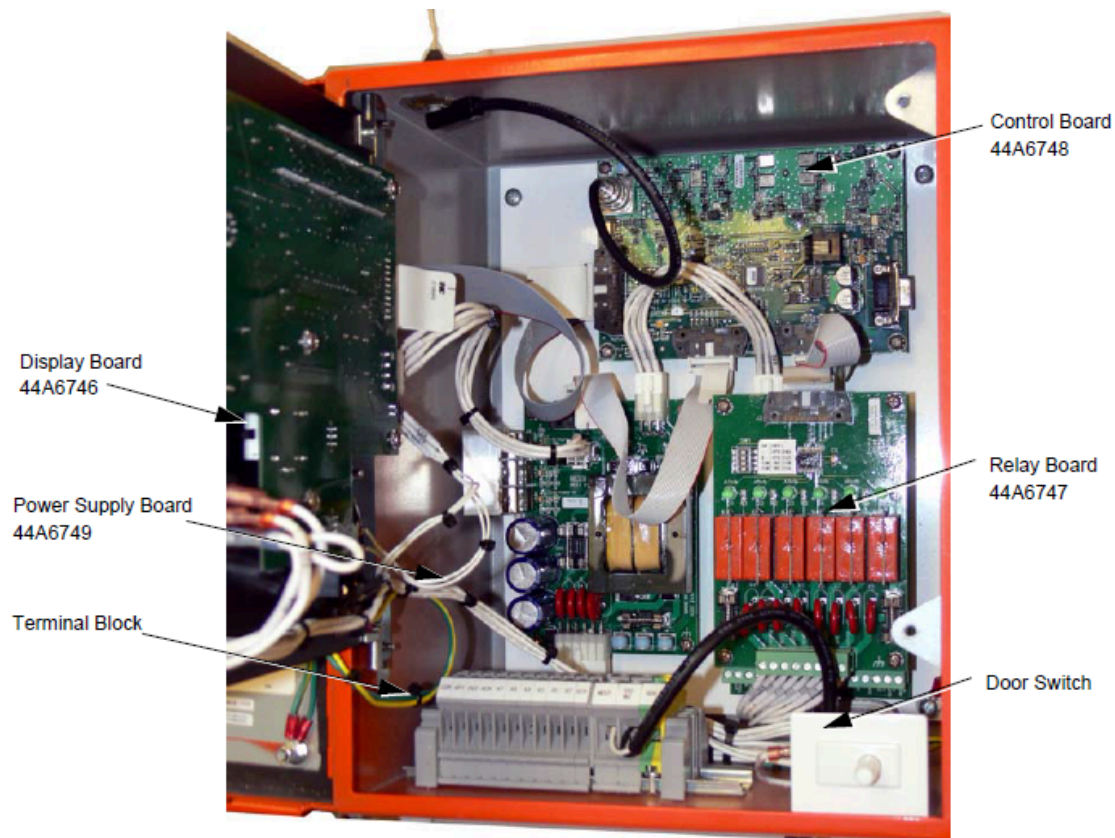

4.2 Terminal Block

See [Table 4](#). The L-854 Radio Control Equipment terminal block is used to interface an air-to-ground Radio Control Equipment with an L-821 control panel, interface panel or direct to an L-828 constant current regulator (CCR). The CCR control voltage can be either +48 V dc or 120 Vac.

Table 4: Terminal Strip Interface

TERMINAL STRIP #	DESCRIPTION
1	I/O Common
2	General I/O (not used)
3	Command Decode Disable (see "Interfacing the Radio Controller" on page 8)
4	ACom - voltage common input for A relays
5	A7clk - Output of A7 (7-click) Relay
6	A5clk - Output of A5 (5-click) Relay
7	A3clk - Output of A3 (3-click) Relay
8	B3clk - Output of B3 (3-click) Relay

Table 4: Terminal Strip Interface

TERMINAL STRIP #	DESCRIPTION	
9	B5clk – Output of B5 (5-click) Relay	
10	B7clk – Output of B7 (7-click) Relay	
11	BCom – voltage common input for B relays	
12	240 or 115V AC Neutral	-12 or -48 VDC (Neg)
13	240 or 115V AC Load	+12 or +48 VDC (Pos)
14 (Green/Yellow)	240 or 115V AC Ground (Green) Cabinet Ground	

4.3 Control Board

Figure 3: Control Board 44A6748

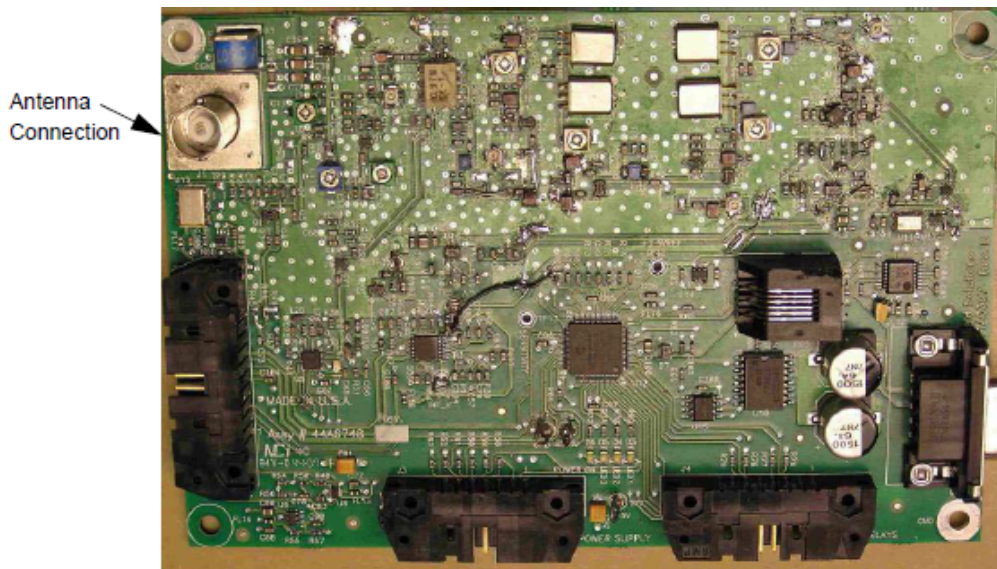

See [Figure 3](#). The Control Board functions as the receiver, decoder, timer and central processor for the Radio Control Equipment.

4.4 Power Supply Board

Figure 4: Power Supply Board 44A6749

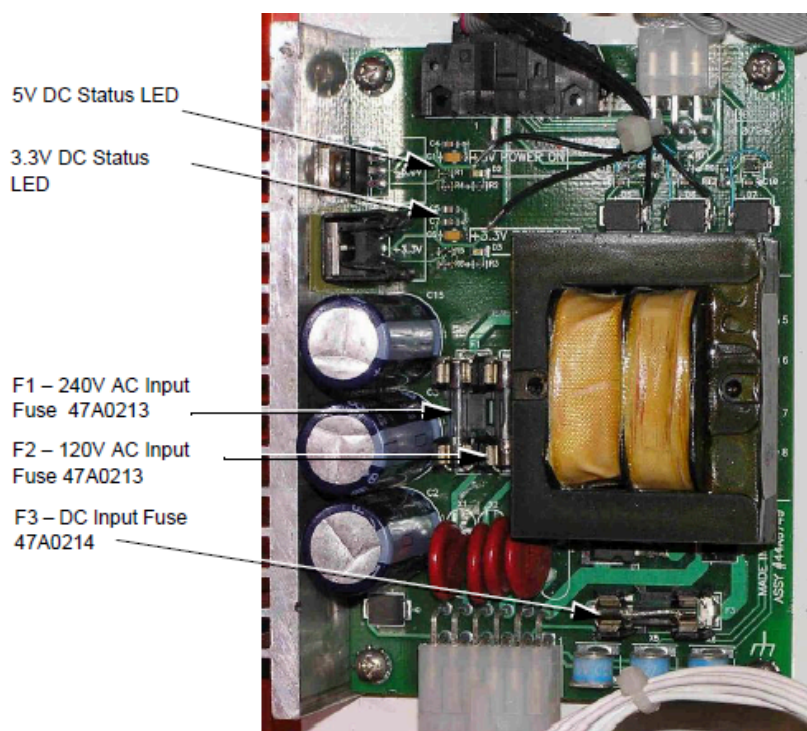

See Figure 4. The Power Supply board provides 5 VDC and 3.3 VDC to the various boards in the system. Input power is brought in through the (see Table 4), Terminal Block at the bottom of the cabinet. Input power options include:

- 120 VAC $\pm 10\%$ 50/60 Hz
- 240 VAC $\pm 10\%$ 50/60 Hz
- 12 VDC $\pm 20\%$
- 48 VDC $\pm 20\%$

Note that the correct wiring harness is included when the unit is shipped from the factory; it is not possible to change the input voltage in the field.

There are two status LEDs on the board. The top LED shows that 5V power is available, and the lower LED shows that 3.3V power is available. The Control Board also monitors the DC voltage output, and will issue an alarm to the display if the voltages are out of specification. See “Troubleshooting” on page 22.

There are three fuses on the board, as shown below in Table 5.

Table 5: Power Supply Fuse Layout

ITEM	PART	DESCRIPTION	FUNCTION
F1	47A0213	.5A 5mm x 20mm SLO BLO	240 VAC Input
F2	47A0213	.5A 5mm x 20mm SLO BLO	120V VAC Input
F3	47A0214	5A 5mm x 20mm SLO BLO	DC Input

4.5 Relay Board

Figure 5: Relay Board 44A7647

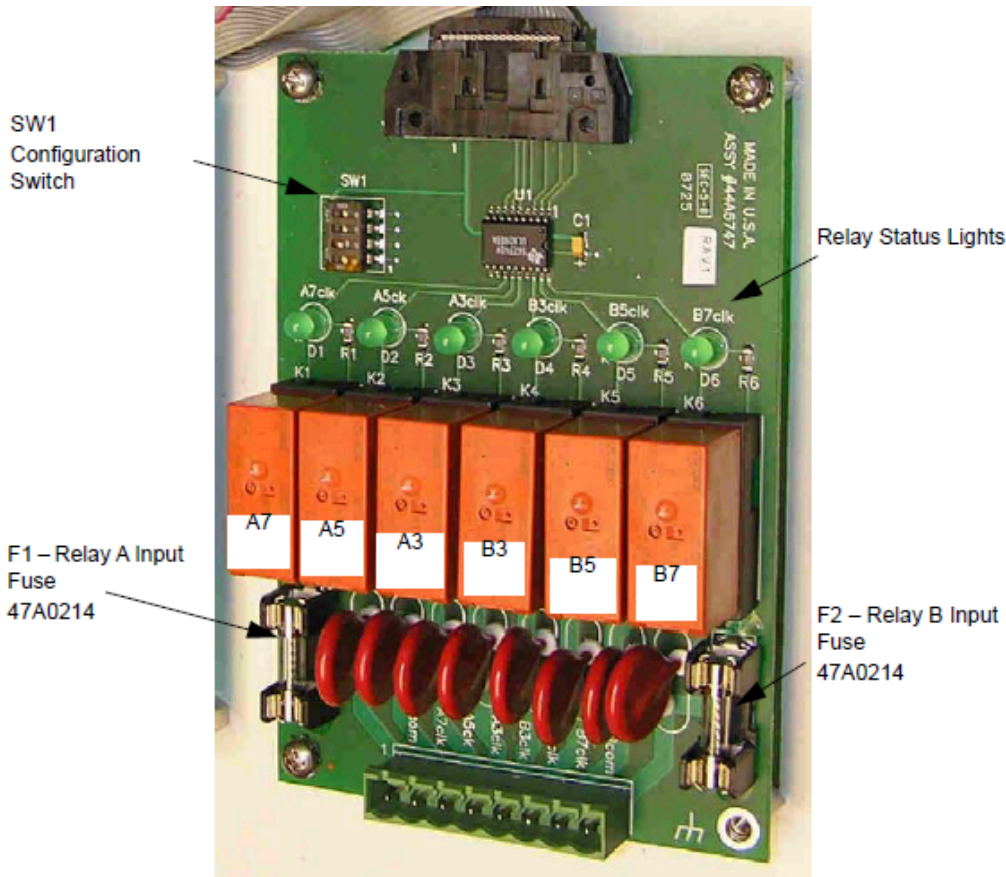

See Figure 5. The Radio Control Equipment provides for relay outputs for control of external lighting. Either of the two relay sets can be configured for either cumulative (incremental) or, individual output. See Figure 4 and Figure 5 for a description of the logic used. All relay contacts are dry, and can switch either +48Vdc or 120Vac through either set of relays for CCR control.

Table 6: Cumulative (Incremental) Operation

Radio Clicks Detected	Active Control Output		
	3	5	7
3-Radio Clicks	●	○	○
5-Radio Clicks	●	●	○
7-Radio Clicks	●	●	●

Table 7: Individual Operation

Radio Clicks Detected	Active Control Output		
	3	5	7
3-Radio Clicks	●	○	○
5-Radio Clicks	○	●	○
7-Radio Clicks	○	○	●

The output voltage required from the relays (usually +48V DC or 120V AC) is provided to the relays through ACom (Terminal Strip #4) for relays A3, A5, A7 or BCom (Terminal Strip #11) for relays B3, B5, B7. See [Table 4](#).

Configuration Switch SW1 is used to set the operational configuration of the Radio Control Equipment. See [Table 8](#) for additional information.

Table 8: Radio Control Configuration Switch

POSITION	DESCRIPTION	ON	OFF
4	Debug Mode	Do Not Use	Debug Mode Off
3	Canada Mode J Operation	Canada Mode J	Standard Operation
2	Relay Channel A Operation	Cumulative Mode	Individual Mode
1	Relay Channel B Operation	Cumulative Mode	Individual Mode

A set of LEDs above each solid state relay shows that relay's commanded status.

There are two fuses on the board, as shown below in [Table 9](#).

Table 9: Relay Board Fuse Layout

ITEM	PART	DESCRIPTION	FUNCTION
F1	47A0214	5A 5mm x 20mm SLO BLO	Ch A Switch Voltage Input
F2	47A0214	5A 5mm x 20mm SLO BLO	Ch B Switch Voltage Input

5.0 Installation



WARNING

Read installation instructions in their entirety before starting installation.

- • Become familiar with the general safety instructions in this section of the manual before installing, operating, maintaining or repairing this equipment.
- • Read and carefully follow the instructions throughout this manual for performing specific tasks and working with specific equipment.
- • Make this manual available to personnel installing, operating, maintaining or repairing this equipment.
- • Follow all applicable safety procedures required by your company, industry standards and government or other regulatory agencies.
- • Install all electrical connections to local code.
- • Use only electrical wire of sufficient gauge and insulation to handle the rated current demand. All wiring must meet local codes.
- • Route electrical wiring along a protected path. Make sure they will not be damaged by moving equipment.
- • Protect components from damage, wear, and harsh environment conditions.
- • Allow ample room for maintenance, panel accessibility, and cover removal.
- • Protect equipment with safety devices as specified by applicable safety regulations.
- • If safety devices must be removed for installation, install them immediately after the work is completed and check them for proper functioning prior to returning power to the circuit.

Failure to follow these warnings may result in serious injury or equipment damage.

This section provides instructions for the installation of the L-854 Radio Control Equipment. Refer to the project plans and specifications for the specific installation instructions.

5.1 Unpacking

The equipment must be handled carefully to prevent component damage. Unpack the carton upon receipt and check the contents and their condition. Note any exterior damage to the carton that might lead to detection of equipment damage.

If you find any damage to equipment, file a claim form with the carrier immediately. Inspection of equipment by the carrier may be necessary.

5.2 Installing L-854 Radio Control Equipment

To install the standard L-854 Radio Control Equipment, perform the following procedure:

1. Determine the best location for the Radio Control Equipment.



Note

Radio Control Equipment location should be within 50 feet (15.24 m) of the antenna and secured to a wall. The standard cabinet (NEMA 4) is rated for an indoor or outdoor environment. Consideration should be given to locating it out of a traffic area to reduce or minimize its exposure to unauthorized personnel. Consideration should also be given to the routing of the antenna lead-in cable, if used. Route it away from heavy concentrations of electrical wires to reduce interference.

2. Use extreme care when drilling the entrance holes for the power, control and, antenna wiring. Avoid drilling into the enclosure in such a way as to allow metal filings can fall onto the electronics or, allowing the drill bit to contact the equipment inside.

- See [Figure 6](#).
Install the radio unit using the four mounting holes.



Note

Use four 1/4 x 1 in.- (6.35 x 25.4 mm-) long lag screws with 1/4 in. flat washers (or other suitable fasteners) for mounting, or as appropriate for the surface to which the radio unit is being mounted.

Figure 6: Mounting Dimensions

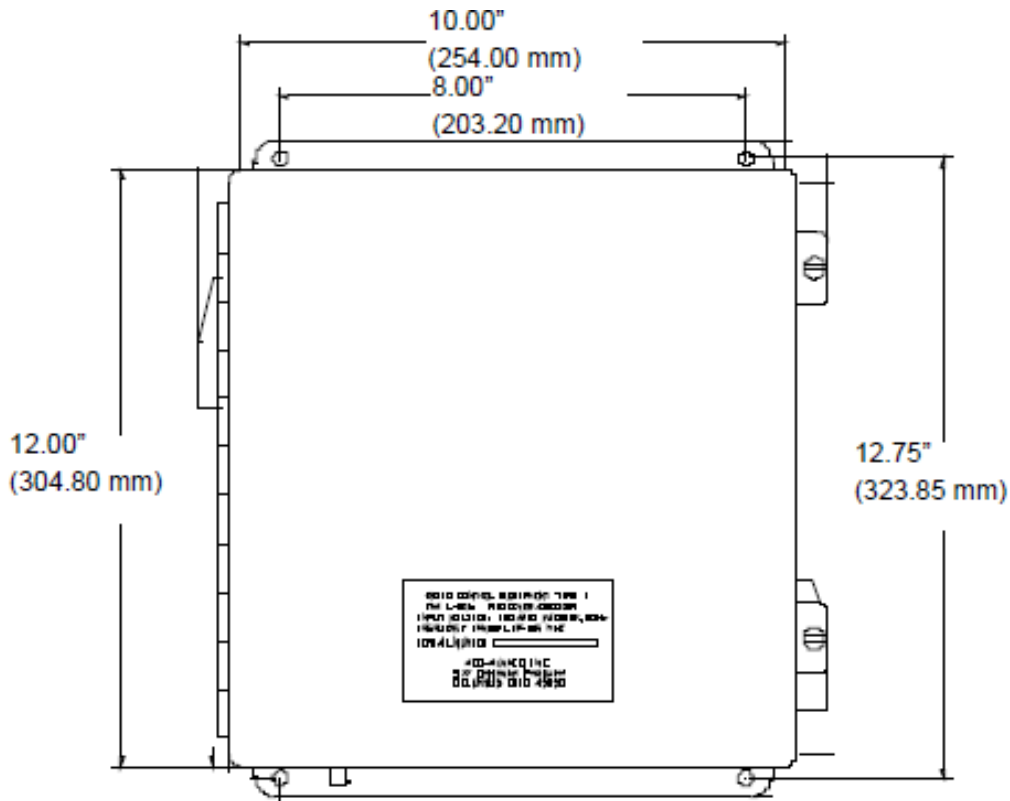

- Route power to the unit.



Note

This must meet the National Electric Code (NEC) and/or any local codes.

- See [Table 4](#).
Connect 120V AC (or 240V AC) to the terminal block as follows:
 - White wire to terminal #12 (neutral)
 - Black wire to terminal #13 (load)
 - Green wire to terminal #14 (ground)Or connect 12V DC (or 48V DC) to the terminal block as follows:
 - Black wire to terminal #12 (negative)
 - Red wire to terminal #13 (positive)
- Connect the Decode Disable signal to terminal 1 and terminal 3, if used.
The Radio Control Equipment will operate in both individual and cumulative control, see [Table 6](#) and [Table 7](#).
- Place the voltage to be switched for the Channel A relays on Terminal 4, and the voltage to be switched for the Channel B relays on Terminal 11.

8. Connect the circuits to be controlled by the Channel A relays to terminals 5 through 7 (as required) as follows:
 - a. Terminal 5 is the output for relay A7 (7-click).
 - b. Terminal 6 is the output for relay A5 (5-click).
 - c. Terminal 7 is the output for relay A3 (3-click).
9. Connect the circuits to be controlled by the Channel B relays to terminals 8 through 10 (as required) as follows:
 - a. Terminal 8 is the output for relay B3 (3-click).
 - b. Terminal 9 is the output for relay B5 (5-click).
 - c. Terminal 10 is the output for relay B7 (7-click).



Note

These relay contacts (Channel A and Channel B) have only a light-duty (3 amp) current-carrying capacity. 2.3.2.1 Remote Antenna (Option)

5.2.1 Remote Antenna (Option)

1. Connect the BNC antenna plug attached to the antenna lead-in wire to the BNC receptacle on the radio unit. Route the antenna cable to the antenna location.



Note

Avoid sharp bends in the antenna cable, and leave a drip loop anywhere the antenna lead-in wire changes from vertical to horizontal. Be sure to secure the antenna lead-in cable so it does not move excessively in the wind to prevent fatigue failure of the cable.

2. Unpack the antenna and become familiar with the parts and hardware.
3. Assemble the remote antenna per the instructions provided.
4. Connect the end of the coaxial cable terminated with antenna connector to the antenna.



Note

To prolong the life of the antenna in or around coastal areas, it is recommended that the hardware be encapsulated with a silicon rubber compound such as Dow-Corning Silastic Rubber or GE Silicone Seal to prevent atmospheric deterioration.

5.2.2 Safety Precautions



WARNING

Installation of the antenna near power lines is dangerous. For your safety, follow the installation directions.

Each year, hundreds of people are killed, mutilated, or receive severe permanent injuries when attempting to install an antenna. In many of these cases, the victim was aware of the danger of electrocution but did not take adequate settings to avoid the hazard. For your safety, and to achieve a good installation, please read and follow the safety precautions below. They may save your life. Follow the safety guidelines below.

- Select your installation site with safety, as well as performance, in mind.
- Plan your installation procedure carefully and completely before you begin.
- Successful raising of a mast or tower is largely a matter of coordination.
- Each person should be assigned to a specific task and should know what to do and when to do it. One person should be designated as the leader of the operation to call out instructions and watch for signs of trouble.

When installing your antenna, remember:

- Do not use a metal ladder.
- Do not work on a wet or windy day.
- Dress properly - shoes with rubber soles and heels, rubber gloves, long sleeve shirt or jacket.

If the assembly starts to drop, get away from it and let it fall. Remember, the antenna, mast, cable, and metal guy wires are all excellent conductors of electrical current. Even the slightest touch of any of these parts to a power line completes an electrical path through the antennas and the installer.

Failure to follow these warnings may result in serious injury or equipment damage.

5.2.3 Mounting Remote Antenna

The antenna should be mounted higher than the roof of the building it is mounted on. It is preferable that it be mounted higher than other obstructions in the immediate area. In the case of a utility pole, mount the antenna part way up the utility pole. If there are other cables or wires running vertically on the utility pole, the vertical part of the antenna should be between 40 in. (1.02 m) and 50 in. (1.27 m) away from the vertical wires/conduit.

To mount the antenna, perform the following procedure:

1. Attach the antenna onto a 1/2 in. (12.7 mm) to 3/4 in. (19.05 mm) pipe or up to 1-3/8 in. (34.925 mm) OD tubing using the provided U-bolt, lockwashers, and hex nuts. The pipe or mast should be rigidly supported so that it does not twist or turn.
2. Secure the cable to the mounting mast every few feet with strap or plastic tape to avoid strain on cable connections.
3. Remove any unnecessary slack from the coaxial cable and use the supplied field attachable connector to connect the end of the cable to the antenna connector of the Radio Controller.

6.0 Operation

This section describes operation of the L-854 Radio Control Equipment.

Figure 7: Radio Control Equipment Controls and Indicators



6.1 Controls and Indicators

See [Figure 7](#), and refer to [Table 10](#). Startup procedures for the L-854 Radio Control Equipment are discussed below.

Table 10: Controls and Indicators

Part	Purpose
Controls	
POWER	Controls primary AC power. The switch lights if AC power is present.
CARRIER TEST	Pressing this button simulates the detection of a carrier “click” on the operation frequency. Pressing the button three times within 5 seconds will set the unit to the lowest brightness setting.
TIMER RESET	Pressing this button will reset the timer to the start of the timer selected by the TIMEOUT switch.
PANEL TEST	This button will light all indicators visible on the front panel while the switch is pressed down.
TIMEOUT	This switch will set the timer to hold lighting controlled by the RCE to the indicated time: 1, 15 (FAA standard), 30, 45 or 60 minutes. The one minute setting is used for internal testing.
SENSITIVITY Min/Max	This will adjust the sensitivity of the receiver to prevent the reception of unwanted signals. This is especially important for Unicom frequencies used by nearby airports. Setting the control closer to Min will prevent transmissions further away from keying the L-854 RCE.
VOLUME Min/Max	This will adjust the volume of transmissions monitored by the internal speaker and the headphones.
DECODER Enable/Disable	Setting the DECODER switch to Disable will prevent any signal from activating the L-854 Radio Control Equipment. The same function can be accomplished through a remote signal through the Terminal Block. Note that the STATUS light will go off when set to the Disable position.
RE-COMMAND Enable/Disable	Setting this switch to Disable will prevent a new signal re-setting the field lighting intensity until it has timed-out from the current session. This is normally set to ENABLE.
SPEAKER On/Off	This will activate the internal speaker when set to On. The normal setting of this switch is Off.
FREQUENCY Up/Down/Enter	Pressing the ← or → keys will adjust the operational frequency up (→) or down (←). Once the desired frequency is displayed, press the ENTER button. After the displays shows VERIFY, press and hold the ENTER button for five seconds to store the frequency in memory, and move the receiver to the desired frequency.
Indicators	
STATUS	Indicates DC power is on, and receiver is operational. Note that the STATUS light will off when the DECODER switch is set to the Disable position.
CARRIER DETECT	Indicates the receiver is receiving a carrier in the proper frequency.
ENERGIZED	Indicates that the output relays are active at the indicated brightness level.
OPERATION SUSPENDED REMOTELY	Indicates that the contacts on the Terminal Block have been closed from a remote source to disable operation (L-821 panel or L-890 computer) See “Interfacing the Radio Controller” on page 8
Frequency Error/Warning Message	The 8 display LED unit will display the operating frequency in normal operation. If an error or warning condition is present, it will display the error code. See Table 11 and Table 12 to decode the error code being displayed.
Output	
Speaker (Grill area)	There is a speaker located behind the grill area of the front panel to listen to transmissions on the selected frequency. The speaker is disabled if the SPEAKER switch is set to Off.
Headphones	¼" headphone jack for connection of a set of headphones. Will operate even if the SPEAKER switch is set to Off.

6.2 Startup Procedures

To start up the Radio Control Equipment, perform the following procedure:

1. **Action:** Turn POWER switch to ON. Be sure that the DECODER switch is set to Enable.
Result: Red light on switch should light. Green STATUS light should light.
2. **Action:** Turn TIMEOUT switch to 1 minute (Test)
3. **Action:** Depress CARRIER TEST Push-button three times within 5 seconds.
Result: The green 10 light next to ENERGIZED should come on. The 3-click relays A3 and B3 should close.
4. **Action:** Wait approximately 60 seconds.
Result: The 3-click relays should open. The green 10 light will go out.
5. **Action:** Depress CARRIER TEST Push-button five times within 5 seconds.
Result: The green 30 light next to ENERGIZED should come on. The 5-click relays should close.



Note

The configuration of SW1 will determine if the 3-click relays will also close.

6. **Action:** Wait approximately 60 seconds.
Result: The 5-click relays should open. The green 10 light will go out.
7. **Action:** Depress CARRIER TEST Push-button seven times within 5 seconds.
Result: The green 100 light next to ENERGIZED should come on. The 7-click relays should close.



Note

The configuration of SW1 will determine if the 3-click and 5-click relays will also close.

8. **Action:** Wait approximately 60 seconds.
Result: The 7-click relays should open. The green 10 light will go out.
9. **Action:** Return the TIMEOUT Switch to your normal setting.
The FAA standard is 15 minutes.
10. **Action:** Enter the desired operating frequency (if different than shown on display) using the ← (down) and → (up) keys to the left of the LED frequency display. Press the ENTER button once. After the displays shows VERIFY, press and hold the ENTER button for five seconds to store the frequency in memory, and move the receiver to the desired frequency.
Result: Unit is now ready for operation.

7.0 Maintenance



WARNING

This equipment contains semiconductor devices and integrated circuits. Static electrical charge buildup in the human body can destroy integrated circuits. Wear a commercially approved ground strap when handling printed circuit boards containing integrated circuits. Wearing a ground strap discharges any static charge buildup to ground and ensures the safety of the integrated circuit. For information on using the ground strap, refer to the ground strap instruction manual.

Failure to follow these warnings may result in serious injury or equipment damage.

This section describes maintenance procedures for the L-854 Radio Control Equipment.

Prior to undertaking any maintenance to this unit, refer to *Theory of Operation* in the Description section.

7.1 Introduction

The only maintenance recommended by people other than skilled radio technicians is changing the fuses and circuit boards. If a problem develops in the unit, make the following checks:

See [Table 4](#).

Make sure that power is coming into the unit by measuring the AC or DC voltage across input power line on Terminals 12 and 13.



Note

If a fuse is blown, replace only with the same size fuse. If the fuse blows again after replacement, consult ADB Technical Service to analyze the problem. See Section "[Power Supply Board](#)" on [page 12](#) for additional information regarding the Power Supply board.

7.2 Receiver Frequency Setting

To set (or change) the operational frequency use the front panel ← (down) and → (up) buttons to select the frequency. Once the correct frequency has been displayed, press the ENTER button once. After the display shows VERIFY press and hold the enter button for five seconds to move the frequency to non-volatile memory, and move the receiver to the new frequency.



Note

The operating frequency is adjustable in steps of 25.0 KHz (0.025 MHz) between 118.0 and 136.0 MHz VHF.

The frequency will be retained if power is lost to the Radio Control Equipment.

8.0 Troubleshooting



WARNING

- Allow only qualified personnel to perform the following tasks. Observe and follow the safety instructions in this document and all other related documentation.
- Make sure power to the L-854 has been disconnected before attempting to service the Radio Control Equipment.

Failure to follow these warnings may result in serious injury or equipment damage.

Refer to [Table 11](#), [Table 12](#) and [Table 13](#). This section provides troubleshooting information for the L-854 Radio Control Equipment.

Table 11: L-854 Radio Control Equipment Error Codes

Code	Description	Solutions
REQ SET	Unable to set tuner frequency	Replace Radio Control Board
FRQ LOAD	Unable to load the frequency assignment from Non-Volatile Memory (Record can not be found)	Replace Radio Control Board
TNR INIT	Unable to initialize the tuner (typically an internal processor error)	Replace Radio Control Board
DSP INIT	Unable to initialize the display board	Replace Radio Display Board
RTC INIT	Unable to initialize the RTC chip	Replace Radio Control Board
ROM INIT	Unable to initialize the Nonvolatile memory	Replace Radio Control Board
A/D FAIL	The A/D Converter has failed	Replace Radio Control Board
ROM CKSM	ROM Checksum failure	Replace Radio Control Board

Table 12: L-854 Radio Control Equipment Warning Codes

Code	Description	Solutions
FRQ LOCK	The synthesizer is not indicating that it is locked to it's assigned frequency	Replace Radio Control Board
FRQ SAVE	Unable to save the assigned frequency to non-volatile memory	Replace Radio Control Board
RTC SAVE	Unable to save to the RTC chip. The power outage logic won't restore the commanded lighting state	Replace Radio Control Board
RTC LOAD	Unable to load data from the RTC chip	Replace Radio Control Board
LOW 5V	5 volt power is below 4.7V DC	Replace Power Supply Board
HIGH 5V	5 volt power is above 5.3V DC	Replace Power Supply Board

Table 12: L-854 Radio Control Equipment Warning Codes

Code	Description	Solutions
LOW 3.3V	3.3 volt power is below 3.0V DC	Replace Power Supply Board
HIGH 3.3V	3.3 volt power is above 3.6V DC	Replace Power Supply Board

Table 13: L-854 Radio Control Equipment Troubleshooting

Problems and Possible Causes	Solutions
Problem: No STATUS light	
<ul style="list-style-type: none"> DECODER switch set to Disable 	Place DECODER switch to Enable
<ul style="list-style-type: none"> Defective lamp 	Check lamp operation using the PANEL TEST button. Replace Display board if lamp is defective.
Problem: ENERGIZED light(s) are on, but relay(s) fail to function properly	
<ul style="list-style-type: none"> Defective Relay board 	Check if green LED(s) are on above relays. Replace relay board if necessary.
Problem: One or more relays are not working correctly	
<ul style="list-style-type: none"> No power switched by indicated relay 	Check if green LED(s) are on above the relay. If yes, but no power is switched, check: <ul style="list-style-type: none"> Fuses F1 and F2 on the relay board are OK, and Check that power is available to AComm and BComm inputs on terminal strip.
<ul style="list-style-type: none"> Defective Relay board 	Replace relay board if necessary.
<ul style="list-style-type: none"> Relays not operating as expected 	Check relay output configuration (cumulative or individual) on SW 1 (Table 8)
Problem: Receiver does not work	
<ul style="list-style-type: none"> Incorrect frequency 	Reset receiver to correct frequency.
<ul style="list-style-type: none"> Defective antenna 	Check antenna and antenna lead.
<ul style="list-style-type: none"> Low (or no) sensitivity 	Increase sensitivity by turning SENSITIVITY toward Max (clockwise)
<ul style="list-style-type: none"> Defective Control board 	Replace Control board.
Problem: No power lamp (switch)	
<ul style="list-style-type: none"> No power 	Check power source.
<ul style="list-style-type: none"> Defective lamp 	Replace switch.
Problem: No lights on front panel display	
<ul style="list-style-type: none"> Front door interlock switch not working 	Test front door interlock switch, replace if necessary.
Problem: Carrier Test button does not work.	
<ul style="list-style-type: none"> SENSITIVITY set at min. 	SENSITIVITY control until CARRIER TEST works correctly.

8.1 Wiring Schematics

8.1.1 Introduction

This section provides wiring schematics for the L-854 Radio Control Equipment.

8.1.2 Wiring Diagram List

[Figure 8](#): 120 VAC Unit, Internal Wiring Diagram

[Figure 9](#): 120 VAC Unit, 40A Relay Option

[Figure 10](#): 240 VAC Unit, Internal Wiring Diagram

[Figure 11](#): 240 VAC Unit, 40A Relay Option

[Figure 12](#): 48 DC Unit, Internal Wiring Diagram

[Figure 13](#): 12 DC Unit, Internal Wiring Diagram

Figure 8: 120 VAC Unit, Internal Wiring Diagram

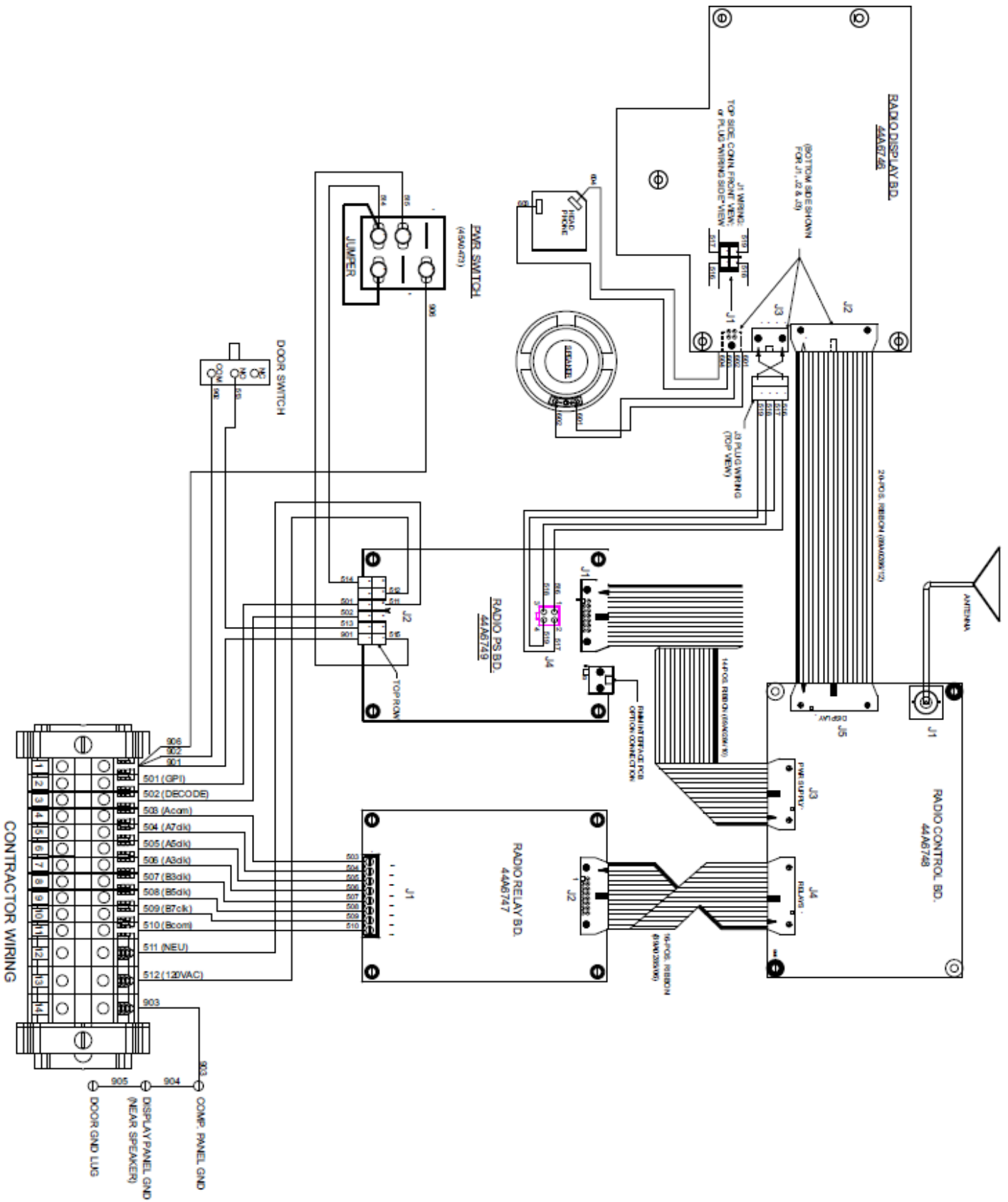
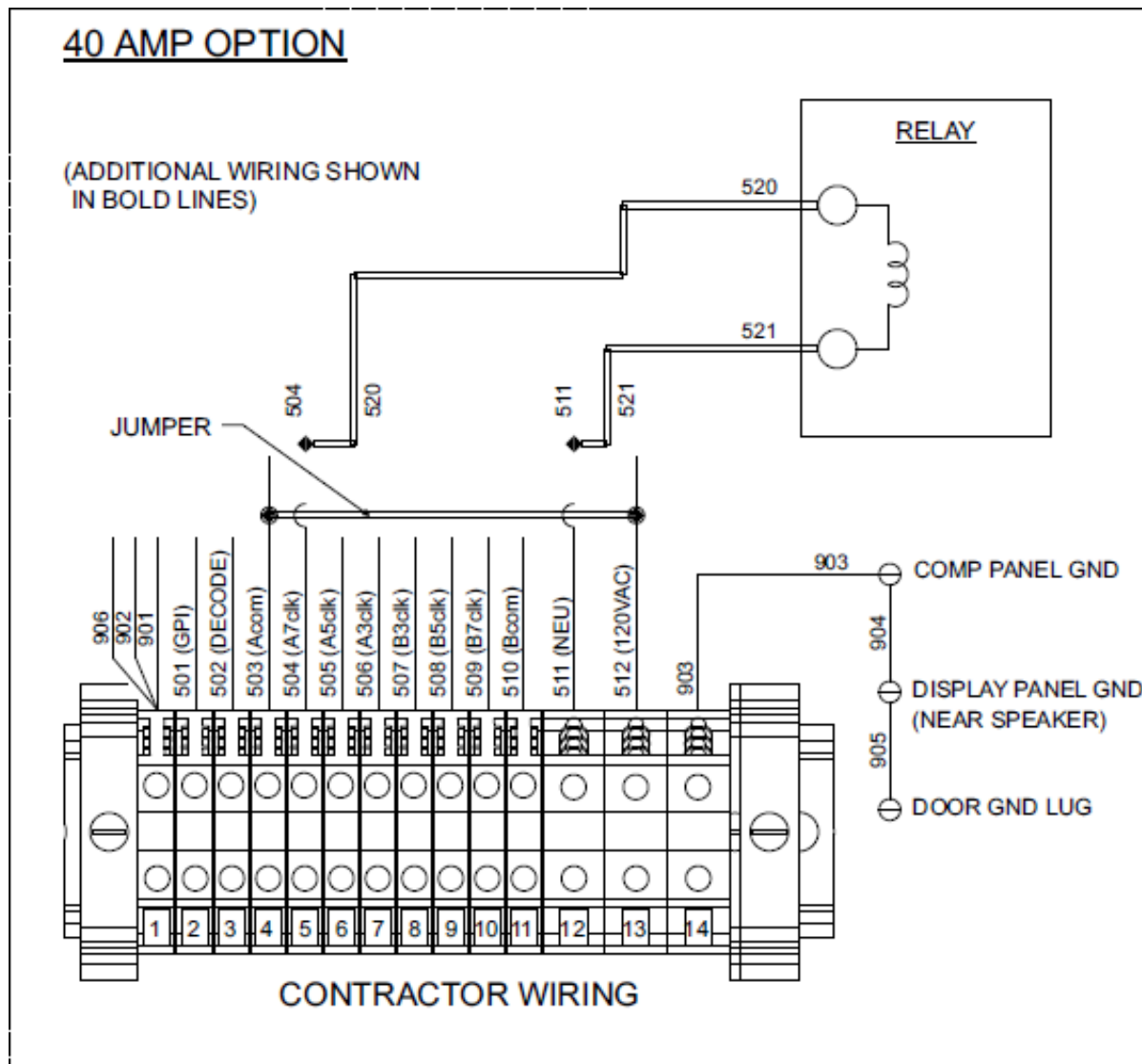

Figure 9: 120 VAC Unit, 40A Relay Option



-SEE PG. 3 FOR OTHER OPTIONS

Figure 10: 240 VAC Unit, Internal Wiring Diagram

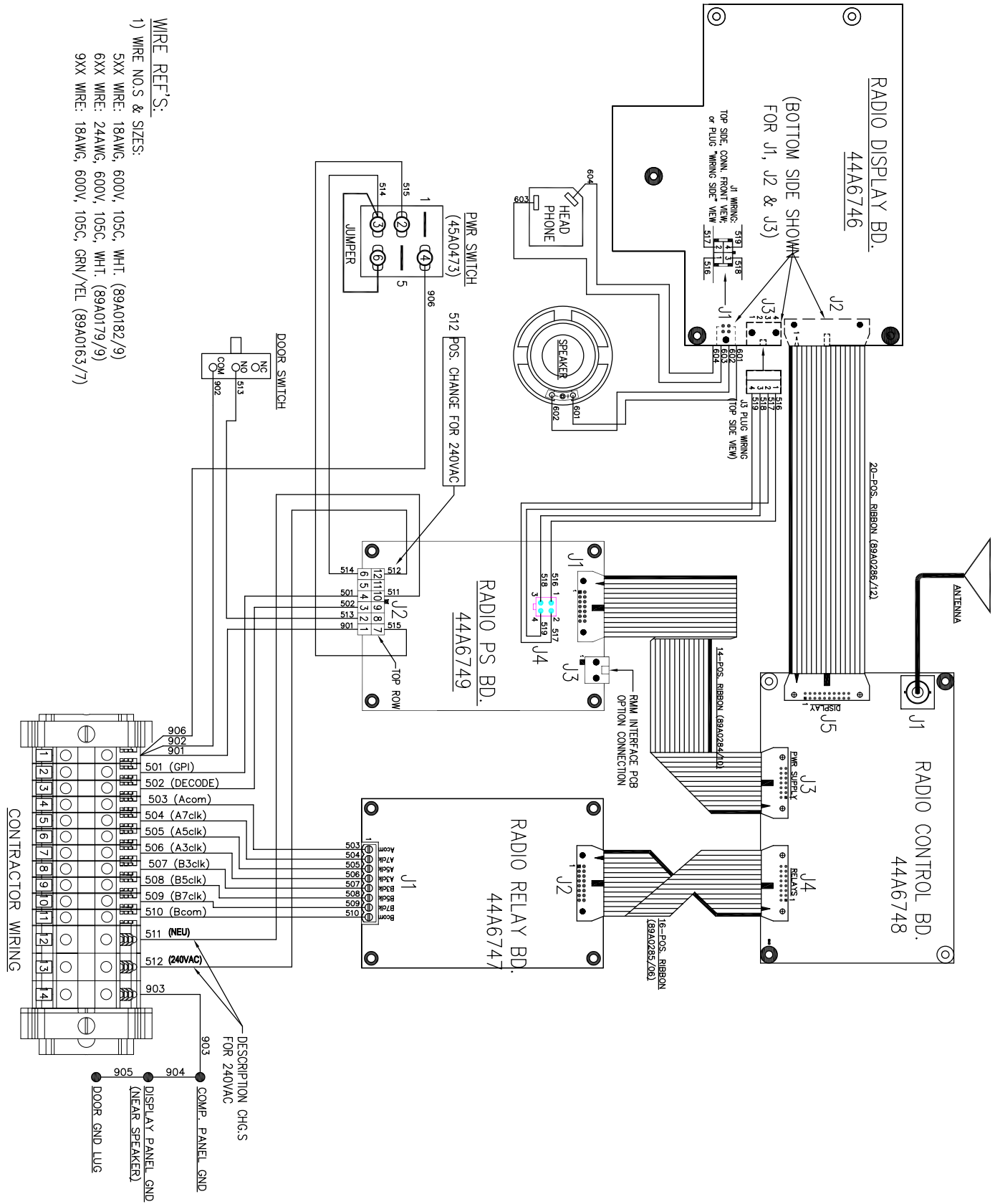

Figure 11: 240 VAC Unit, 40A Relay Option

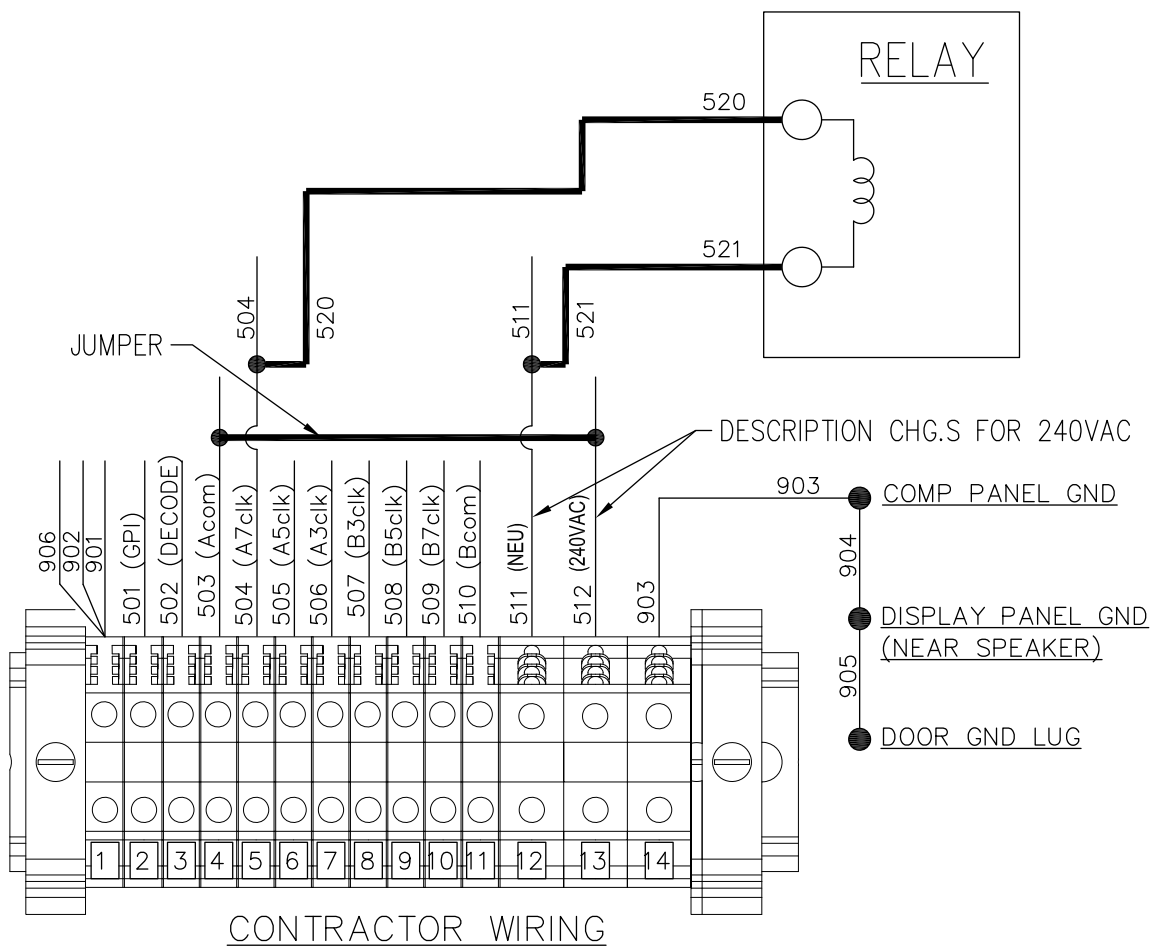

Figure 12: 48 DC Unit, Internal Wiring Diagram

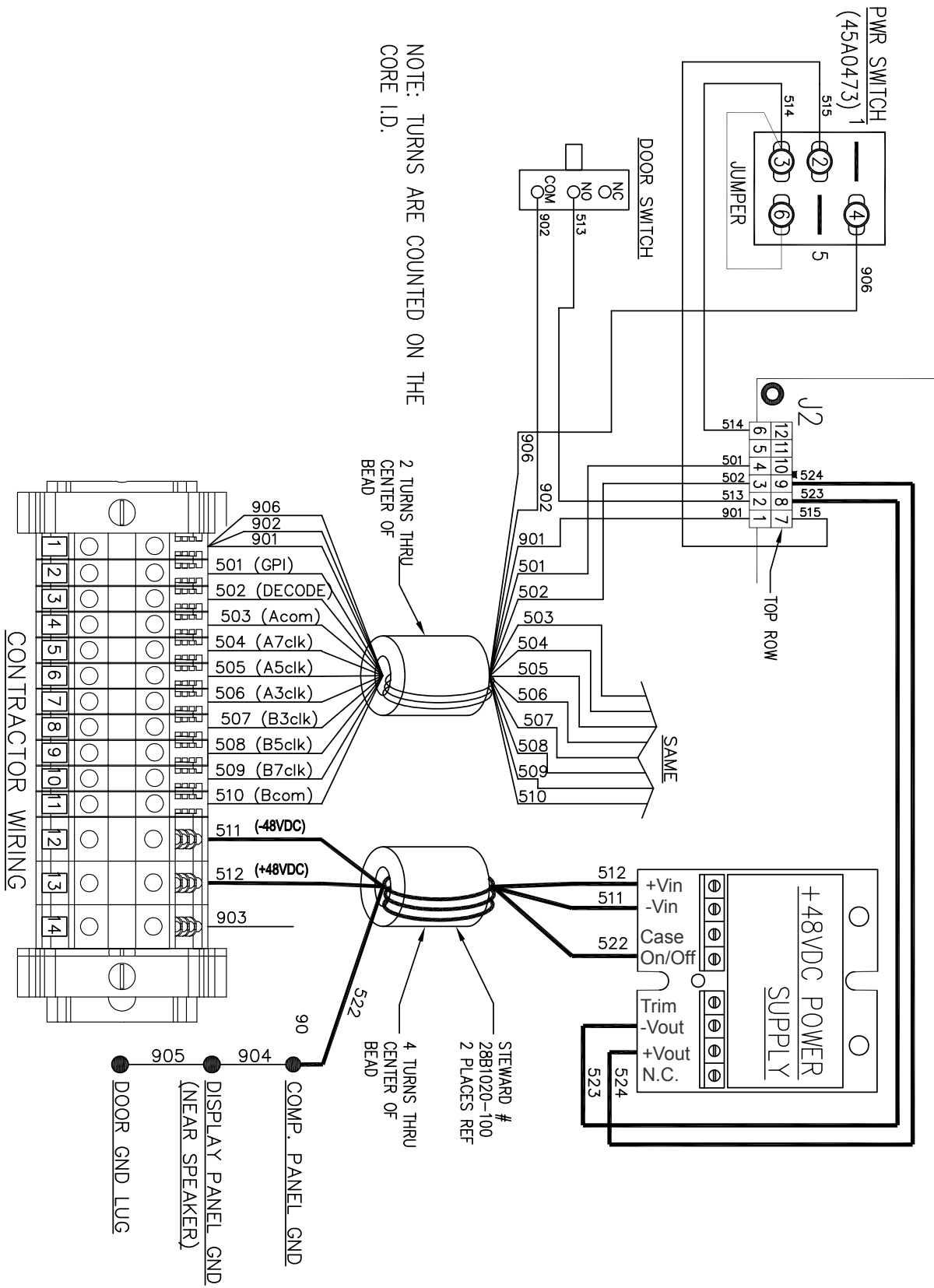
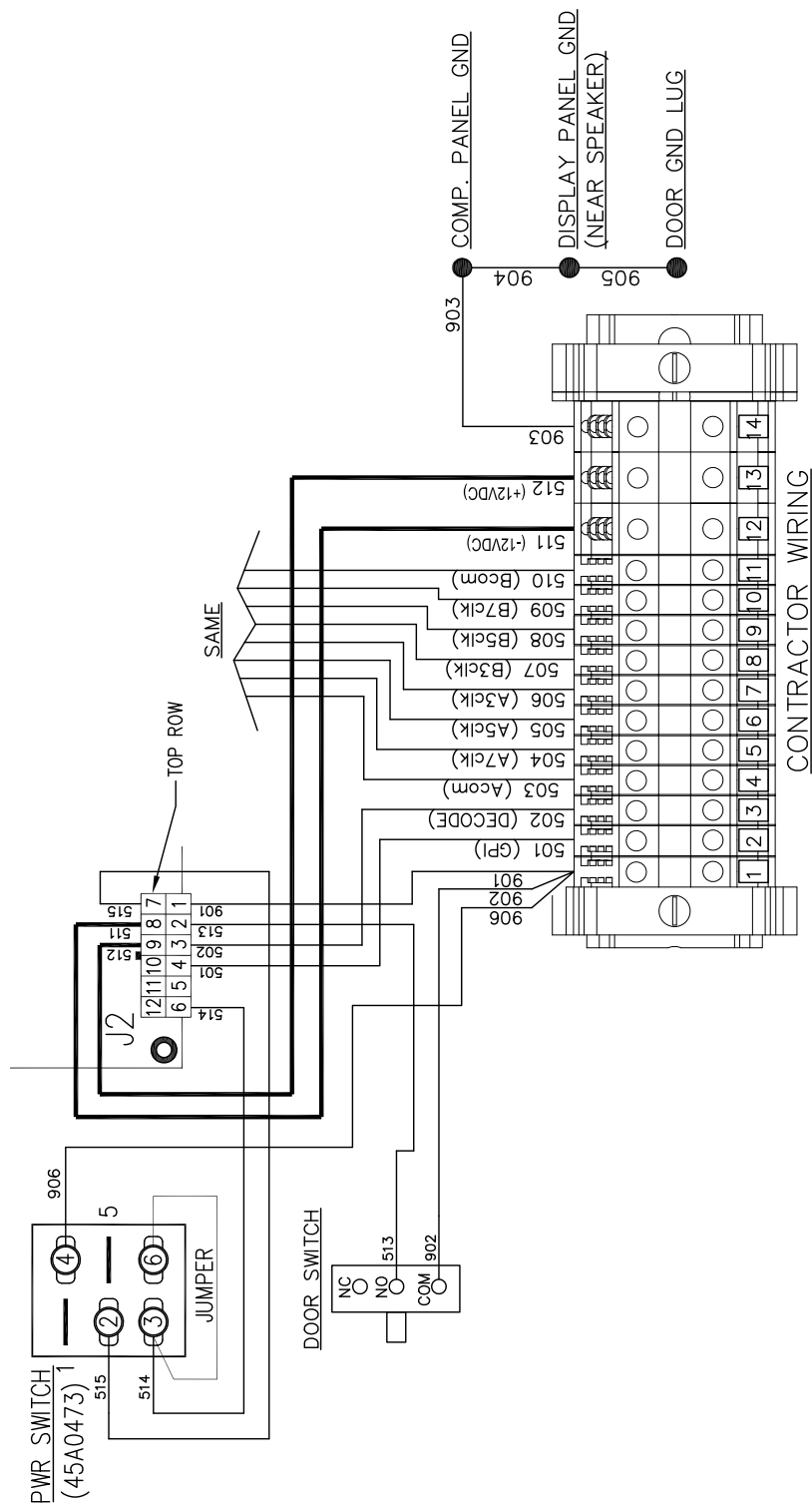

Figure 13: 12 DC Unit, Internal Wiring Diagram



9.0 Parts

9.1 Ordering Code

To order parts, call ADB SAFEGATE Customer Service or your local ADB SAFEGATE representative. This subsection describes information to help order the parts for the L-854 Radio Control Equipment.

Ordering Code

	Power	Antenna	Enclosure Type	Output
RCE	□	□	□	□
				1

Enclosure Type

1 = NEMA 4 (indoor/outdoor)

Output

1 = 0 to 3 A

2 = 3 to 40 A (single step)

Power

1 = 120 VAC, ±10%, 50/60 Hz

2 = 240 VAC, ±10%, 50/60 Hz¹

3 = 12 VDC ±20%¹

4 = 48 VDC ±20%¹

Antenna

1 = Top Mount

2 = Remote Antenna (with standard antenna)²

3 = Remote Antenna (with heavy duty antenna)^{2,3}

4 = Remote Mount (without antenna and coax)⁴

¹ Not ETL Certified.

² The remote antenna is an omnidirectional ground-plane antenna with an additional 50 feet of cable for remote mounting.

³ For use in locations with high wind or ice.

⁴ For use in locations with an existing antenna and coax.

9.2 Parts Diagrams

Figure 14: RCE Display View

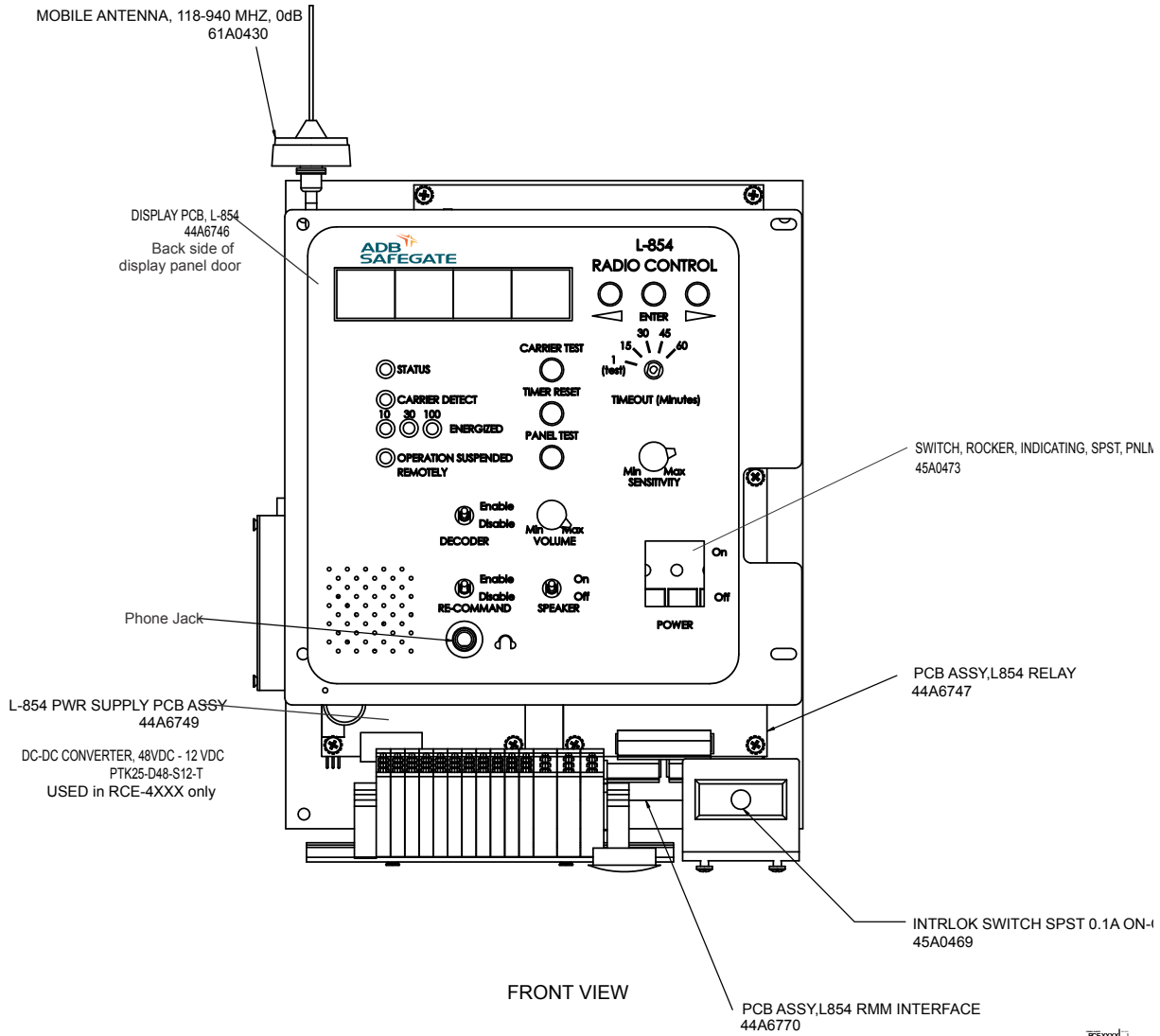
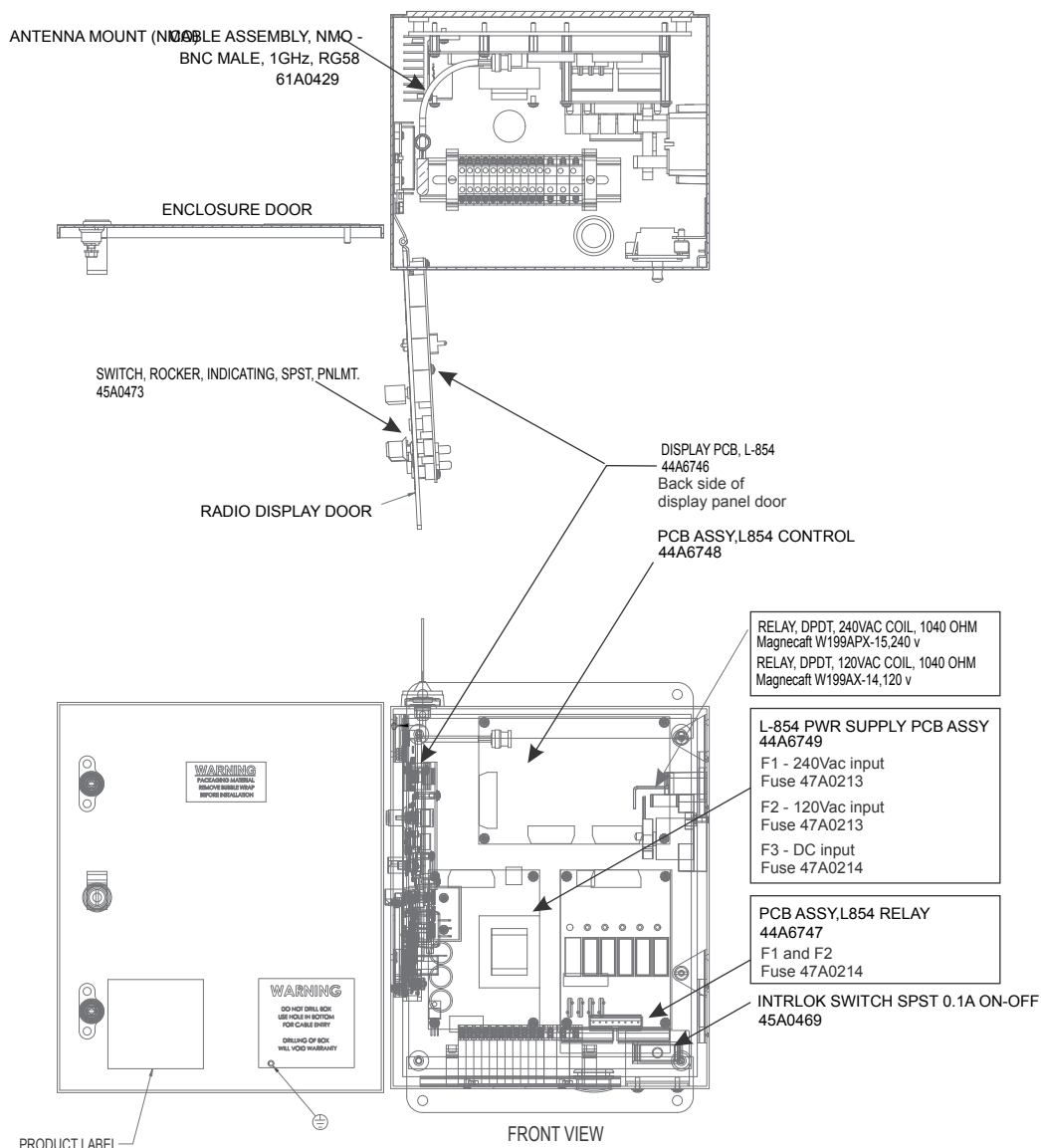

Figure 15: RCE Interior Views



RCExxxx 1

9.3 Spare Parts

Create a sufficiently large stock of spare parts to maintain the L -854 RCE Digital Radio Control in the field. Consider acquiring approximately 10% spare final assemblies (with a minimum quantity of 1) for the total amount of equipment in the field. This allows for repairs to be made in the shop. Components that are more likely to need replacement, such as PCB subassemblies should be stocked in smaller quantities. For the unit, it is highly recommended to have a least one entire unit as a spare, or for larger installations, at least 10% of the total units installed.

For the L -854 unit, see the table below for spares.

- Consider acquiring 10% spares for critical components noted as (A) in the table below. If only a small number of units are installed, consider acquiring at least 1 of each of the components noted as (A) below.
- Also consider acquiring 1% spares for parts noted as (B) in the table below. If it is important to have a robust level of spare parts on hand, and only a small number of units are installed, consider acquiring 1 of each of the components noted as (B) below.

Table 14: Spare Parts

Part Number	Description	Location	Note	Spares
44A6748	Radio Control Board	Figure 15		A
44A6749	Radio Power Supply Board	Figure 14		A
44A6747	Radio Relay Board (3A)	Figure 15		A
44A6746	Radio Display Board	Figure 14		A
45A0473	Power Switch	Figure 15		A
45A0469	Door Interlock Switch	Figure 14		A
53A0432	Relay (40A)	Wiring Diagrams	Option	
89A0286/12	20-pos Ribbon Cable	Wiring Diagrams		B
89A0284/10	14-pos Ribbon Cable	Wiring Diagrams		B
89A0285/06	16-pos Ribbon Cable	Wiring Diagrams		B
47A0213	Fuse, .5A 5mm x 20mm SLO BLO	Figure 15	3	A
47A0214	Fuse, 5A 5mm x 20mm SLO BLO	Figure 15	3	A
61A0430	Whip Antenna			B
61A0429-01	Internal Antenna Mounting Kit (with cable)			B
61A0447	Remote Antenna Cable (50 ft / 12.24m)		Option	
61A0447/100	Remote Antenna Cable (100 ft / 30.5m)		Option	
61A0448	Standard Remote Antenna (Rami AV-5)		Option	
61A0470	Heavy Duty Remote Antenna (Rami AV-1)		Option	

Appendix A: Support

Our experienced engineers are available for support and service at all times, 24 hour/7 days a week. They are part of a dynamic organization making sure the entire ADB SAFEGATE is committed to minimal disturbance for airport operations.

ADB SAFEGATE Support

Technical Support – Global

Customers in Europe, the Middle East, Africa and Asia Pacific are more than welcome to our portal for technical support. Trained in all areas of system issues, troubleshooting, quality control and technical assistance, our highly experienced Technical support specialists are available 24 hours a day, seven days a week to provide assistance over the phone.

Europe: **+32-2-722-17-11**

China: **+86-10-8476-0106**

Middle East and Africa: **+971-4-452-7575**

In the Americas, we also offer live technical support.

Live Technical Support – Americas

If at any time you have a question or concern about your product, contact ADB SAFEGATE's US-based technical support specialists, available 24 hours a day, seven days a week, to assist you via phone.

ADB SAFEGATE Americas Technical Service & Support (US & Canada) :**+1-800-545-4157**

ADB SAFEGATE Americas Technical Service & Support (Canada): **+1-905-631-1597**

ADB SAFEGATE Americas Technical Service & Support (International): **+1-614-861-1304**. For technical service press 3 and for sales support press 4.

We can also be reached via email during regular business hours.

Airfield and Gate: **techservice.us@adbsafegate.com**

Gate: **gateservice.us@adbsafegate.com**

We look forward to working with you!

Before You Call

When you have an airfield lighting or control system problem, prior to calling, please ensure the following:

- Review the product's manual and troubleshooting guide.
- Be located with the product ready to troubleshoot.
- Have all necessary information available: airport code/company name, customer id number, contact phone number/email address, product/part number.
- Have all necessary tools that may be needed at hand.

When calling about an issue with Safedock A-VDGS, we can serve you better if you collect the following information before you call:

- Relevant information regarding the issue you are calling about, such as gate number, flight number, aircraft type and time of the event.
- What, if any, actions have been taken to resolve the issue prior to the call.
- If available, provide a CCTV recording of the incident to aid in aligning the information from the Safedock log file.

For more information, see www.adbsafegate.com, contact ADB SAFEGATE Support via email at **support@adbsafegate.com**.

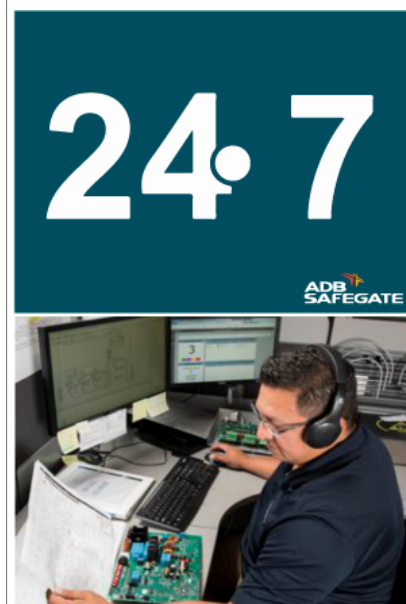

A.1 ADB SAFEGATE Website

The ADB SAFEGATE website, www.adbsafegate.com, offers information regarding our airport solutions, products, company, news, links, downloads, references, contacts and more.

A.2 Recycling

A.2.1 Local Authority Recycling

The disposal of ADB SAFEGATE products is to be made at an applicable collection point for the recycling of electrical and electronic equipment. The correct disposal of equipment prevents any potential negative consequences for the environment and human health, which could otherwise be caused by inappropriate waste handling. The recycling of materials helps to conserve natural resources. For more detailed information about recycling of products, contact your local authority city office.

A.2.2 ADB SAFEGATE Recycling

ADB SAFEGATE is fully committed to environmentally-conscious manufacturing with strict monitoring of our own processes as well as supplier components and sub-contractor operations. ADB SAFEGATE offers a recycling program for our products to all customers worldwide, whether or not the products were sold within the European Union (EU).

ADB SAFEGATE products and/or specific electrical and electronic component parts which are fully removed/separated from any customer equipment and returned will be accepted for our recycling program.

All items returned must be clearly labeled as follows:

- For Restriction of Hazardous Substances (*RoHS*)/Waste Electrical and Electronic Equipment (*WEEE*) Recycling
- Sender contact information (Name, Business Address, Phone number).
- Main Unit Serial Number.

ADB SAFEGATE will continue to monitor and update according for any future requirements for *EU directives* as and when *EU member states* implement new *regulations* and or *amendments*. It is our aim to maintain our *compliance plan* and assist our customers.

Company Addresses

ADB SAFEGATE, Belgium	ADB SAFEGATE BV Leuvensesteenweg 585 B-1930 Zaventem Belgium
Contact:	
Tel.: +32 2 722 17 11	Email: marketing@adbsafegate.com
Fax: +32 2 722 17 64	Internet: www.adbsafegate.com
ADB SAFEGATE, Americas	ADB SAFEGATE Americas, LLC 700 Science Blvd Gahanna, OH 43230 USA
Contact:	
Tel.: +1 (614) 861 1304	Email: sales.us@adbsafegate.com
Fax: +1 (614) 864 2069	Internet: www.adbsafegate.com
ADB SAFEGATE, Sweden	ADB SAFEGATE Sweden AB Djurhagegatan 19 SE-213 76 Malmö Sweden
Contact:	
Tel.: +46 (0)40 699 17 00	Email: marketing@adbsafegate.com
Fax: +46 (0)40 699 17 30	Internet: www.adbsafegate.com
ADB SAFEGATE, China	ADB SAFEGATE Airfield Technologies Ltd. China Unit 603, D Block, CAMIC International Convention Center, No 3, Hua Jia Di East road, ChaoYang district, Beijing 100102 P.R. China
Contact:	
Tel.: +86 (10) 8476 0106	Email: china@safegate.com
Fax: +86 (10) 8476 0090	Internet: www.adbsafegate.com
ADB SAFEGATE, Germany	ADB SAFEGATE Germany GmbH Konrad-Zuse-Ring 6, D-68163 Mannheim Germany
Contact:	
Tel.: +49 (621) 87 55 76-0	Email: marketing@adbsafegate.com
Fax: +49 (621) 87 55 76-55	Internet: www.adbsafegate.com

WWW.ADBSAFEGATE.COM

Empowering the Airside Evolution

SMARTER. BETTER. NOW.



Copyright ©2010—2026 ADB SAFEGATE, All Rights Reserved