



## Model 6495

### Freezing Rain Sensor

PRODUCT MANUAL  
6495/Rev

  
**ADB  
SAFEGATE**

## A.0 Disclaimer / Standard Warranty

### CE certification

The equipment listed as CE certified means that the product complies with the essential requirements concerning safety and hygiene. The European directives that have been taken into consideration in the design are available on written request to ADB SAFEGATE.

### ETL certification

The equipment listed as ETL certified means that the product complies with the essential requirements concerning safety and C22.2 No.180:13 (R2018) regulations. The CSA directives that have been taken into consideration in the design are available on written request to ADB SAFEGATE.

### All Products Guarantee

ADB SAFEGATE will correct by repair or replacement per the applicable guarantee below, at its option, equipment or parts which fail because of mechanical, electrical or physical defects, provided that the goods have been properly handled and stored prior to installation, properly installed and properly operated after installation, and provided further that Buyer gives ADB SAFEGATE written notice of such defects after delivery of the goods to Buyer. Refer to the Safety section for more information on Material Handling Precautions and Storage precautions that must be followed.

ADB SAFEGATE reserves the right to examine goods upon which a claim is made. Said goods must be presented in the same condition as when the defect therein was discovered. ADB SAFEGATE further reserves the right to require the return of such goods to establish any claim.

ADB SAFEGATE's obligation under this guarantee is limited to making repair or replacement within a reasonable time after receipt of such written notice and does not include any other costs such as the cost of removal of defective part, installation of repaired product, labor or consequential damages of any kind, the exclusive remedy being to require such new parts to be furnished.

ADB SAFEGATE's liability under no circumstances will exceed the contract price of goods claimed to be defective. Any returns under this guarantee are to be on a transportation charges prepaid basis. For products not manufactured by, but sold by ADB SAFEGATE, warranty is limited to that extended by the original manufacturer. This is ADB SAFEGATE's sole guarantee and warranty with respect to the goods; there are no express warranties or warranties of fitness for any particular purpose or any implied warranties of fitness for any particular purpose or any implied warranties other than those made expressly herein. All such warranties being expressly disclaimed.

### Standard Products Guarantee

Products manufactured by ADB SAFEGATE are guaranteed against mechanical, electrical, and physical defects (excluding lamps) which may occur during proper and normal use for a period of two years from the date of ex-works delivery, and are guaranteed to be merchantable and fit for the ordinary purposes for which such products are made.

---

#### NOTE



See your applicable sales agreement for a complete warranty description.

Replaced or repaired equipment under warranty falls into the warranty of the original delivery. No new warranty period is started for these replaced or repaired products.

---

### FAA Certified products manufactured by ADB SAFEGATE

ADB SAFEGATE L858 Airfield Guidance Signs are warranted against mechanical and physical defects in design or manufacture for a period of 2 years from date of installation, per FAA AC 150/5345-44 (applicable edition).

ADB SAFEGATE LED products (with the exception of obstruction lighting) are warranted against electrical defects in design or manufacture of the LED or LED specific circuitry for a period of 4 years from date of installation, per FAA EB67 (applicable edition). These FAA certified constant current (series) powered LED products must be installed, interfaced and powered with and through products certified under the FAA Airfield Lighting Equipment Program (ALECP) to be included in this 4 (four) year warranty. This includes, but is not limited to, interface with products such as Base Cans, Isolation Transformers, Connectors, Wiring, and Constant Current Regulators.

# Contents

<b>1. Technical Specifications .....</b>	<b>4</b>
<b>2. Theory of Operation .....</b>	<b>5</b>
2.1 General .....	5
2.2 Functional Description .....	6
2.2.1 Communication .....	7
<b>3. Installation .....</b>	<b>9</b>
3.1 Installation .....	9
3.1.1 Mechanical Mounting .....	9
3.1.2 Power and Data Connections .....	9
<b>4. Operation .....</b>	<b>11</b>
<b>5. Maintenance .....</b>	<b>12</b>
5.1 Standard Maintenance .....	12
5.2 AWOS Maintenance .....	13
5.2.1 Monthly Maintenance .....	13
5.2.2 Quarterly Maintenance .....	13
5.2.3 Annual Maintenance .....	13
<b>6. Troubleshooting .....</b>	<b>14</b>
<b>7. Drawings .....</b>	<b>15</b>

## 1. Technical Specifications

Output Range	Mass equivalent between 0.020 and 0.10 inches (0.5 mm and 2.5 mm)
Output Format	RS-232 (9600, 2400, 300 baud)
Input Power	115 vac, 55-65 Hz
Power Consumption	5 Watts in ice sensing mode; 350 Watts in deicing mode
Size	19" H x 19" W x 4" D
Weight	16 lbs. (7.25 kg)

## 2. Theory of Operation

### 2.1 General

The ADB Safegate Model 6495 Freezing Rain Sensor uses an ultrasonically vibrating probe to detect the presence of icing conditions. The vibrating frequency of the probe (nominally 40,000 hertz) decreases with the accumulation of ice, frost, or wet snow. After ice has accumulated on the probe to a predetermined thickness, the AWOS DCP instructs the sensor to turn on its internal heaters to deice the probe. During deicing, maximum heater power is 400 watts. The deicing system is capable of completely melting approximately 3.8 mm of ice on the probe and strut within 30 seconds at -20 degrees Celsius (°C). The heat sink dissipates the heat from the probe assembly following a deice cycle. The heat sink provides a recovery time (i.e., the time required for the sensor to revert to ambient temperature) of 10 minutes following a deice cycle. The heat sink also thermally isolates the probe assembly from the electronics, which allows accurate measurement at temperatures at or close to 0 °C (32 °F). Frequency values and status are reported to the AWOS once each minute. The system combines information from the freezing rain sensor with data from other AWOS sensors to generate the required reports of freezing rain.

A "sensor event" begins (or continues, following a de-icing) when the vibration frequency indicates 0.005 inches of ice accretion, and the rate of frequency decrease exceeds 0.002 inches in 15 minutes. The event ends whenever the frequency indicates less than 0.005" of ice, or whenever the rate of ice accretion is less than 0.002" in 15 minutes. A "system event" is reported from the AWOS only after combining the sensor's output with data from the AWOS present weather sensor and temperature sensor.

## 2.2 Functional Description

The Freezing Rain Sensor uses an ultrasonic axially vibrating probe to detect the presence of icing conditions. This sensing probe is a nickel alloy tube mounted in the strut at its midpoint with 1 inch (25.4mm) exposed to the atmosphere. This tube exhibits magnetostrictive properties and expands and relaxes under the influence of a variable magnetic field. A magnetic bias field is provided by a magnet mounted inside the strut and modulated by a drive coil surrounding the lower half of the tube. A magnetostrictive oscillator (MSO) circuit is created by the addition of a pickup coil and operational amplifier. The ultrasonic axial movement of the tube resulting from the activation of the drive coil causes a current to be induced in the pickup coil. The current from the pickup coil drives the operational amplifier, which provides the signal for the drive coil. The oscillation frequency of the circuit is determined by the natural resonant frequency of the sensor tube, which is tuned to approximately 40,000 hertz. As the ice detector encounters an icing environment, ice collects on the sensing probe. The added mass of accreted ice causes the frequency of the sensing probe to decrease in accordance with the laws of classical mechanics. A 0.02-inch (0.5mm) thickness of ice on the probe causes the operating frequency of the probe to decrease by approximately 133 hertz. The ice detector control circuitry utilizes a microprocessor to monitor probe frequency when instructed by the CDP. The ice detector deices itself through internal heating elements in both the strut and probe. After the ice detector is deiced, the sensing probe cools quickly and is ready to sense ice formation again.

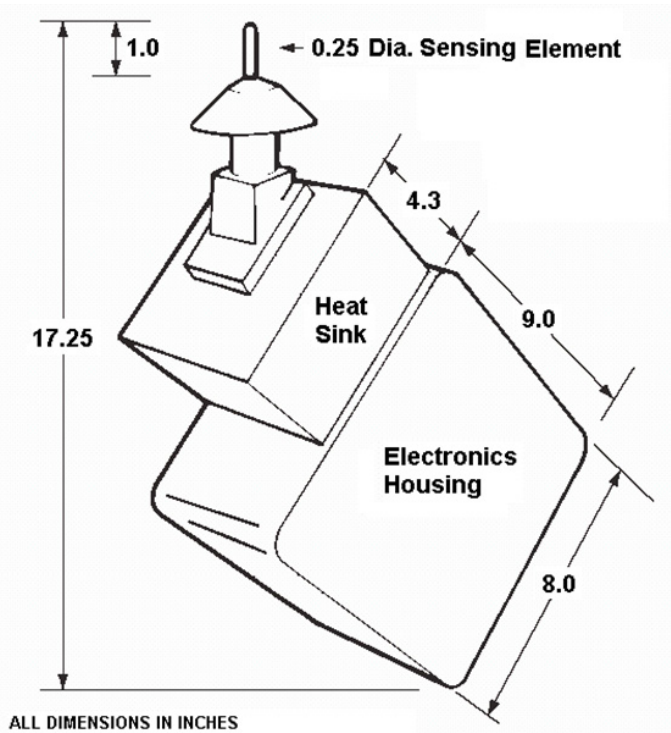

**Figure 1. Freezing Rain Sensor Components**

### Probe Assembly

The probe assembly consists of the probe (sensing element), the strut, and the deice collar. The strut contains pickup and drive coils, cartridge heaters, a magnet, and a retaining spring. The probe assembly minimizes the flat area around the probe and contains radial grooves machined in the conical portion of the strut. This design prevents water droplets from collecting around the probe nodal area in still air conditions. The deice collar aids in breaking up ice that may form on the heat sink. The sensor water shedding ability eliminates false signals due to water refreezing at the base when the atmosphere does not contain liquid water to actually form ice on the probe element.

### Heaters.

Deicing is accomplished using a heater brazed in the interior of the probe. A pair of cartridge heaters deice the strut. During deicing, the maximum power drain is 400 watts. The deicing system is capable of completely melting approximately 3.8mm of ice on the strut and probe within 30 seconds at -20°C.

## Model 6495 Freezing Rain Sensor

### *Heat Sink*

The heat sink consists of a 4.5-pound (2.05 kilograms) mass of anodized 6061 aluminum that separates the electronics and probe strut. The heat sink provides heat dissipation for the probe and strut during deicing.

The purpose of the heat sink is to achieve a recovery time (defined as the time required for the sensor to revert to ambient temperature after being deiced). The heat sink thermally isolates the sensing element from the electronics heat, which allows accurate measurement at temperatures at or close to 0°C.

### *Microcontroller*

The sensor uses an M80C51FB 8-bit microcontroller. This chip contains an internal RS-232 interface. The unit's firmware is contained on a separate ultraviolet erasable programmable read only memory (UVEPROM) chip mounted on a socket. This permits the unit's software to be easily changed in the field by removing the UVEPROM chip from its socket and replacing it with a chip containing the new program. An electrically erasable programmable read only memory (EEPROM) is used to store data and tables used in computation. The unit also features a nonvolatile read and write memory (RAM) chip that permits any detected failure codes to be stored in the unit. A failed unit can be brought back to a repair facility and the failure code read to determine how the unit failed.

### *Watchdog Timer/Reset Power Monitor*

A single chip combines the function of watchdog timer and power monitor. The purpose of the watchdog timer is to monitor the operation of the microcontroller. The microcontroller must output a pulse into the watchdog timer approximately every second or the watchdog timer causes the microcontroller to go into a reset condition, which reinitializes the microcontroller. The power monitor circuit causes the microcontroller to reset any time that the voltage drops below 4.65 vdc, which is the lower operational voltage for the memory circuits. Any time that the voltage drops below 4.25 vdc, it is possible for the memory circuits to lose memory. The power monitor maintains the microcontroller in a reset condition until the supply voltage is above 4.65 vdc.

### *Heater Control*

The heater control circuit consists of a mechanical relay with a solid-state interface circuit to the microcontroller. When ice has accreted on the probe to a predetermined thickness (typically 2.0mm), the CDP instructs the heater circuit to furnish 115 vac to the heaters in the probe and strut, causing the ice to melt. A mechanical relay is used instead of a solid state relay to avoid any leakage current that might flow through the heater circuit when the relay is in a de-energized state. A leakage current would cause some heating of the probe, which would have an adverse effect on freezing rain detection, especially around 0°C ambient air temperature. There is a feedback circuit to the microcontroller to ensure that the relay is operating properly.

## **2.2.1 Communication**

The Freezing Rain Sensor communicates with the DCP via an RS-232 interface. It transmits a data packet once per minute to the DCP. The data packet contains the current probe frequency, along with sensor status. The CDP determines current freezing rain conditions using the reported frequency and the AWOS freezing rain algorithm. **Table 1** shows the commands sent by the DCP and the corresponding response from the sensor. When a sensor failure is detected, it is reported on the CDP main and diagnostic screens, and is recorded in the maintenance log.

Command Description	Command	Response
Send Routine Data	Z1	<b>ZPS40000</b> Z – Sensor ID P – Status (P/F/D) P = Pass F = Fail D = Deice S – Status Descriptor " " = Okay (blank) 1 = Probe Failure 2 = Deicing Failure 3 = Electronics Failure 40000 – frequency in Hz
Perform Deice Cycle	Z3XX (XX = 01 – 60 secs)	<b>ZDOK</b>
Perform Extended Diagnostics	Z4	<b>ZF2</b> Z – Sensor ID P – Status (P/F/D) P = Pass F = Fail D = Deice S – Status Descriptor " " = Okay (blank) 1 = Probe Failure 2 = Deicing Failure 3 = Electronics
Field Calibration	F5	<b>ZPS40000</b> Z – Sensor ID P – Status (P/F/D) P = Pass F = Fail D = Deice S – Status Descriptor " " = Okay (blank) 1 = Probe Failure 2 = Deicing Failure 3 = Electronics Failure 40000 – Calibration frequency

**Table 1. Freezing Rain Sensor Commands and Responses**

## 3. Installation

### 3.1 Installation

#### 3.1.1 Mechanical Mounting

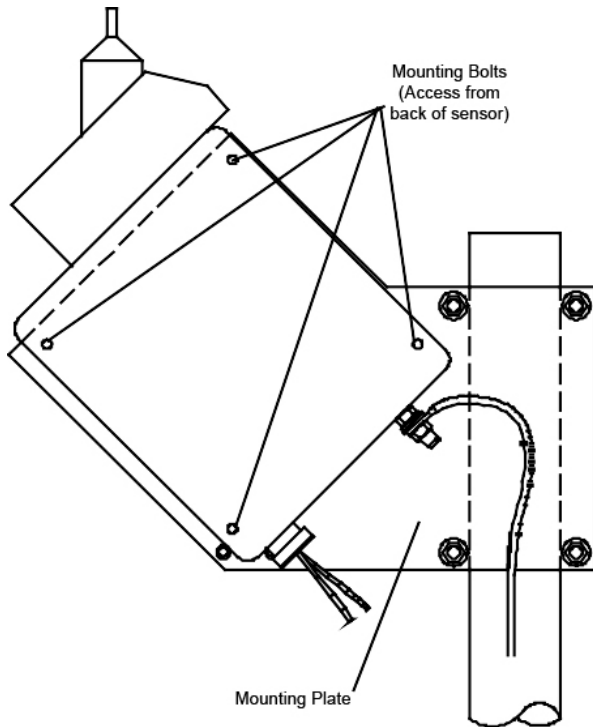

**Figure 2.** Freezing Rain Sensor Components

#### 3.1.2 Power and Data Connections

The Freezing Rain Sensor comes pre-installed on a flat mounting plate, which in turn attaches to a standard 2 1/2" pipe using U-bolts.

1. Set the sensor into position on the mounting pole, approximately 5 1/2' above ground level.
2. Install one U-bolt from the back (pole side) of the mounting plate, so that the pole sits in the "U". Feed the bolt ends through the plate's top two mounting holes and fasten with flat washers, lock washers, and nuts.
3. Install the second U-bolt through the bottom two mounting holes and fasten with flat washers, lock washers, and nuts.
4. Tighten all hardware.

##### 3.1.2.1 Power

The sensor utilizes 115vac (103.5 to 126.5 vrms), 55 to 65 hertz input power. The power cable connects to a standard three-prong ac receptacle. Normal operation continues for power interruptions of less than 10 milliseconds. Power interruptions greater than 10 milliseconds cause the sensor to go into a reset condition. Under this condition, the sensor resumes operation automatically after power is reapplied and the power-up test sequence completes.

The internal power connections are shown below. Terminals 1 and 2 and terminals 4 and 5 are on separate circuit breakers.

## Model 6495 Freezing Rain Sensor

Terminal	Function
1	115 vac, hot, electronics
2	115 vac, neutral, electronics
3	Chassis ground (model 0872C2 only)
4	115 vac, hot, heater
5	115 vac, neutral, heater
E1	Chassis ground(model 0872C3 only)

### 3.1.2.2 Data

The freezing rain sensor communicates with the DCP via an RS-232 interface daughter board mounted to the main PCB. The data cable from the sensor is unterminated at the DCP end and connects to the RS-232 interface board at screw terminals on terminal block TB1 as shown in Figure 3.

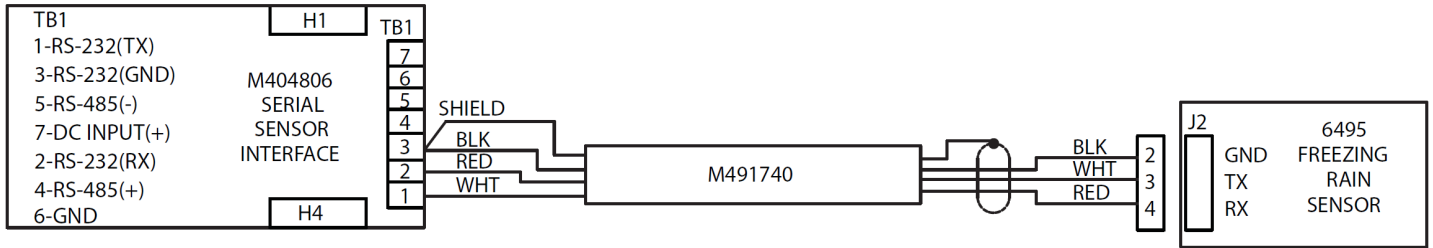

**Figure 3. DCP Data Connections**

## **4. Operation**

The Freezing Rain Sensor operates automatically, receiving commands from and sending data packets to the DCP. There are no controls or indicators on the sensor, nor is there an internal power switch.

## 5. Maintenance

### 5.1 Standard Maintenance

Periodic maintenance should include the following:

The freezing rain sensor should be inspected and the probe cleaned, if necessary, every 90 days. Clean the probe only when it is contaminated with foreign material such as dirt, oil, fingerprints, etc.

Tools and Equipment Required:

- Soft cotton cloth (lint free)
- Isopropyl alcohol

---

#### **WARNING**



Freezing rain sensor probe assembly will be hot if sensor recently completed a deice cycle. Ensure that probe assembly has cooled before cleaning probe. While in the deice mode, the probe will radiate a significant amount of heat. This can be observed by placing hand close to, but not on, the sensor probe. Always avoid direct contact of the probe with skin to avoid burn potential hazard.

---

#### **CAUTION**



Do not touch the probe with bare hands, as oil residue from skin will affect the performance of the sensor.

---

1. Inspect all mounting hardware and cable assemblies for wear and damage.
2. Visually inspect surface of probe for contaminants such as dirt, oil, fingerprints, etc.
3. If any contaminants are present, clean probe using isopropyl alcohol and soft cotton cloth.

## 5.2 AWOS Maintenance

### 5.2.1 Monthly Maintenance

During monthly maintenance of the 6495 Freezing Rain Sensor, perform the following:

1. Inspect all mounting hardware and cable assemblies for wear and damage; repair or replace as needed.

### 5.2.2 Quarterly Maintenance

During quarterly maintenance of the 6495 Freezing Rain Sensor, perform the following:

1. Inspect all mounting hardware and cable assemblies for wear and damage; repair or replace as needed.
2. Visually inspect surface of probe for contaminants such as dirt, oil, fingerprints, etc.
3. If any contaminants are present, clean probe using isopropyl alcohol and soft cotton cloth.



#### **WARNING**

Freezing rain sensor probe assembly will be hot if sensor recently completed a deice cycle. Ensure that probe assembly has cooled before cleaning probe. While in the deice mode, the probe will radiate a significant amount of heat. This can be observed by placing hand close to, but not on, the sensor probe. Always avoid direct contact of the probe with skin to avoid burn potential hazard.

---



#### **CAUTION**

Do not touch the probe with bare hands, as oil residue from skin will affect the performance of the sensor.

---

### 5.2.3 Annual Maintenance

During quarterly maintenance of the 6495 Freezing Rain Sensor, perform the following:

1. Inspect all mounting hardware and cable assemblies for wear and damage; repair or replace as needed.
2. Clean probe using isopropyl alcohol and soft cotton cloth, observing the warnings detailed above.

## 6. Troubleshooting

Symptom	Possible Causes	Action
Freezing rain data missing, or "F" displayed for sensor status	Loose cable or connector	Check all cables and connectors. Repair or replace, if necessary
	No power to freezing rain sensor	Check main power to the sensor is ON
	Freezing Rain Sensor software locked up	Cycle power to sensor. If no recovery, cycle power to the FDCU. If no recovery, replace sensor.
	Freezing Rain Sensor has failed	Consult the SYSLOG for errors prior to the sensor going missing to confirm faulty operation before failure. Replace sensor, if necessary.
Freezing rain data intermittent	Loose cables or connectors	Check all cables and connectors. Repair or replace, if necessary.
	Freezing Rain Sensor is faulty	Consult the SYSLOG for errors and examine the freezing rain status word for possible causes of the problem. Replace sensor, if necessary.
Freezing Rain data inaccurate	Freezing Rain Sensor requires maintenance	Perform complete maintenance.
	Freezing Rain Sensor has operational errors	Cycle power to sensor. If no recovery, cycle power to the FDCU. If no recovery, replace sensor.
	Freezing Rain Sensor software has locked up	Cycle power to sensor. If data still inaccurate, replace sensor.
	Probe frequency incorrect	Check the probe frequency from the FDCU LCD display. If out of tolerance, replace the sensor.
Ice fails to melt from probe	Freezing rain heater or processor has failed or Software has locked up	Cycle power to sensor. If ice still fails to melt, replace sensor.

## 7. Drawings

The following pages contain drawings to help in the installation, use, and maintenance of this instrument.

REVISIONS			DWG NO. 6495-003	
REV	ECO	DESCRIPTION	DATE	APPROVED
A	5019	INITIAL RELEASE	4/2004	PK
B	1526	ADD ITEM 25, GROUND LUG TO TRAVEL W/ UNIT	8/15/08	BRG

- NOTES: UNLESS OTHERWISE SPECIFIED;
- 1 REMOVE OPTICAL CONVERTOR ASSEMBLY AND DISCARD.
  - 2 MARK LABEL ITEM (9) WITH MODEL 6495, ECO NUMBER, REVISION LEVEL AND SERIAL NUMBER. PLACE ON SIDE OF UNIT AS SHOWN.
  - 3 SPLIT CABLE BUSHING ITEM (5) TO ALLOW INSERTION OF POWER AND SIGNAL CABLE ASSEMBLIES.
  - 4 BAG ITEM (3), ITEM (10), ITEM (11), ITEM 25 (GROUND LUG, NOT SHOWN) TO TRAVEL WITH UNIT.

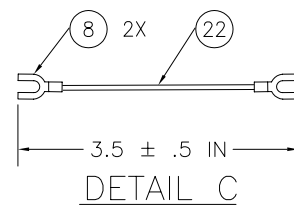
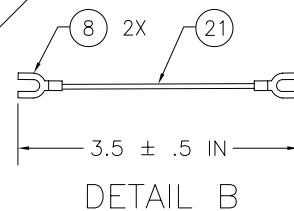
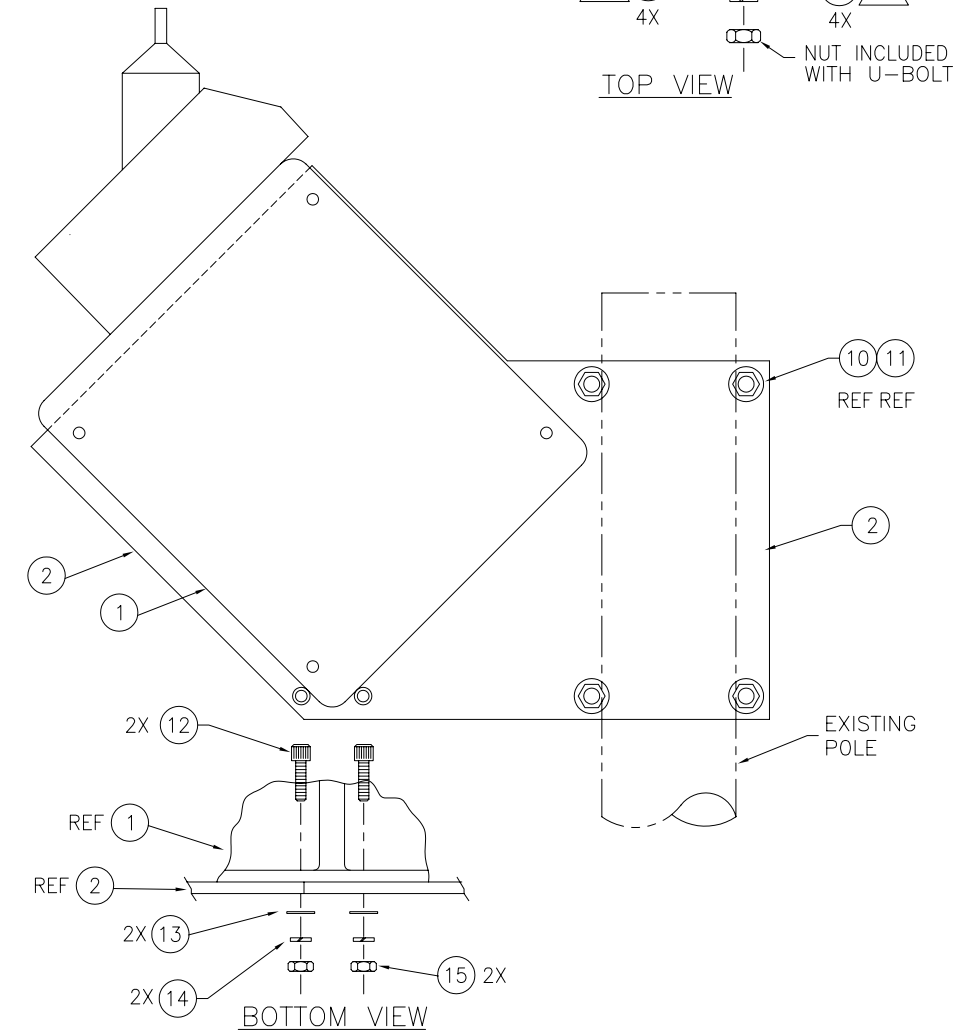
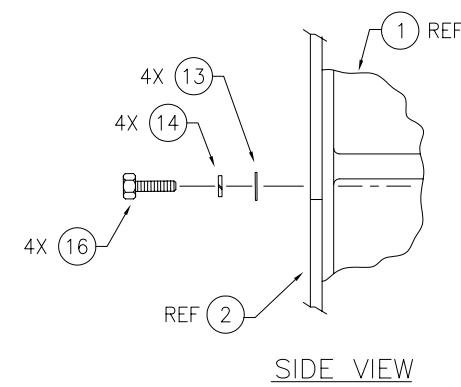
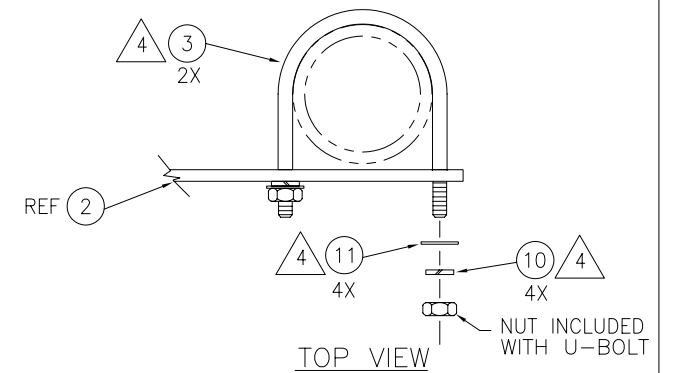
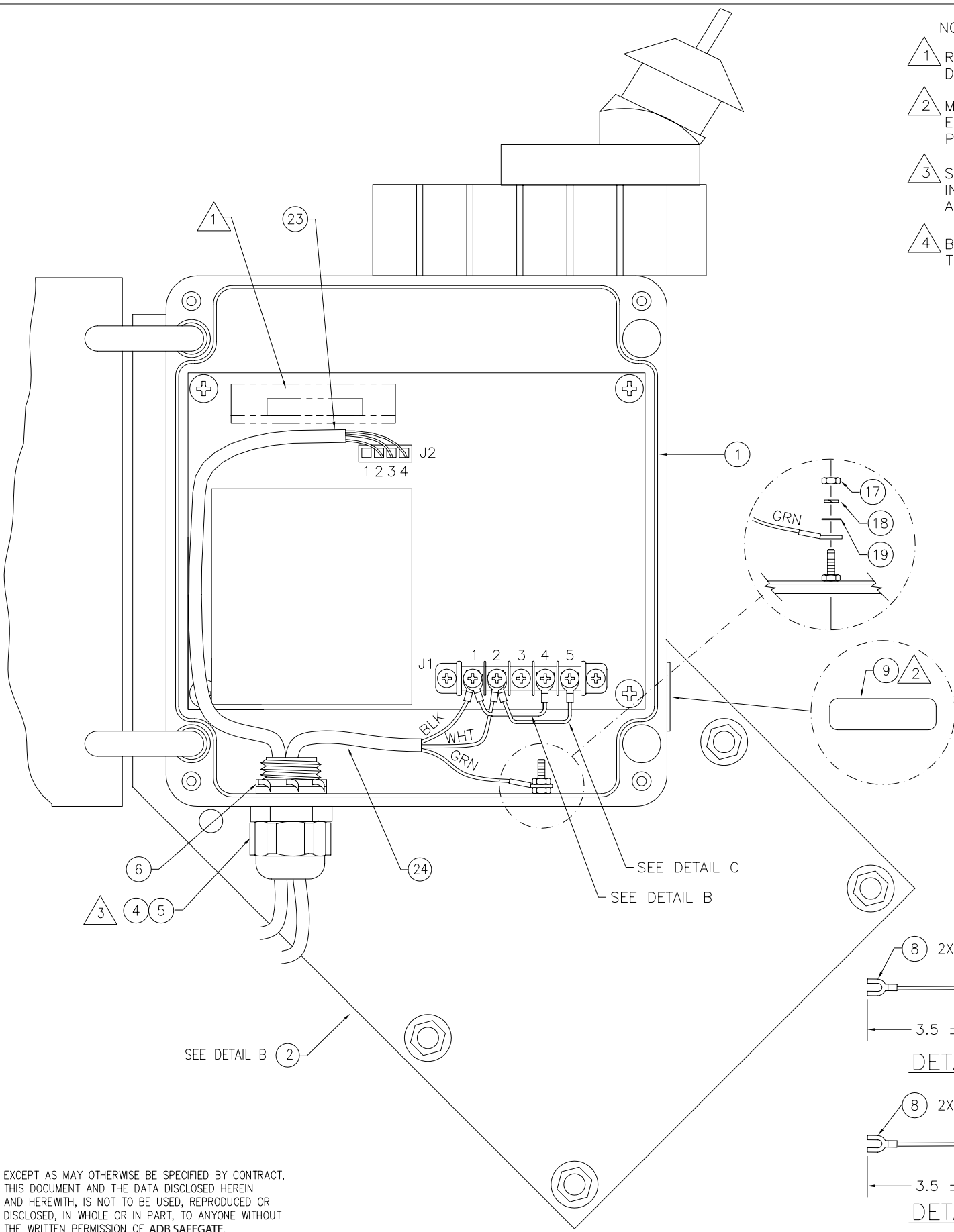

DETAIL B  
SCALE: 1/2

EXCEPT AS MAY OTHERWISE BE SPECIFIED BY CONTRACT, THIS DOCUMENT AND THE DATA DISCLOSED HEREIN AND HEREWITH, IS NOT TO BE USED, REPRODUCED OR DISCLOSED, IN WHOLE OR IN PART, TO ANYONE WITHOUT THE WRITTEN PERMISSION OF ADB SAFEGATE.

APPEND THE FOLLOWING DOCUMENTS WHEN CHANGING THIS DOCUMENT:		UNLESS OTHERWISE SPECIFIED: DIMENSIONS ARE IN INCHES		DRAWN BY: PK		4/06/04		TITLE		ADB SAFEGATE
		TOLERANCES XX=±.010 ANGLES ±1/2" XXX=±.005 CONCENTRICITY: .003 TIR DO NOT SCALE DRAWING		REVISED BY: GALARPE		8/15/08		ASSEMBLY DRAWING, FREEZING RAIN SENSOR, AWOS		
		MATERIAL: SEE BILL OF MATERIALS		CHECKED BY:				SIZE		D
		FINISH: AS ISSUED		DESIGN ENGINEER:				DWG NO.		
		TREATMENT:		PROJECT MANAGER:				6495-003		SCALE 1/1
				APPROVALS		DATE		RELEASE DATE		

NOTES: UNLESS OTHERWISE SPECIFIED;

1. CUT OFF DRAIN WIRE AT SHEATH, BOTH ENDS.

2 REMOVE (.25<sup>+0.13</sup><sub>-.00</sub>) INSULATION. TIP TIN ONLY.

3 COVER EXPOSED CONDUCTORS WITH 1" OF SHRINK TUBING, ITEM 4.

4 MARK LABEL (P/N M434026) ITEM 5 WITH "M491740" AND CURRENT ECO NUMBER AND REVISION LEVEL. ATTACH TO CABLE ASSEMBLY WHERE SHOWN.

REVISIONS			DWG NO. M491740-003	
REV	ECN	DESCRIPTION	DATE	APPROVED
A	5019	INITIAL RELEASE	4/2004	PK

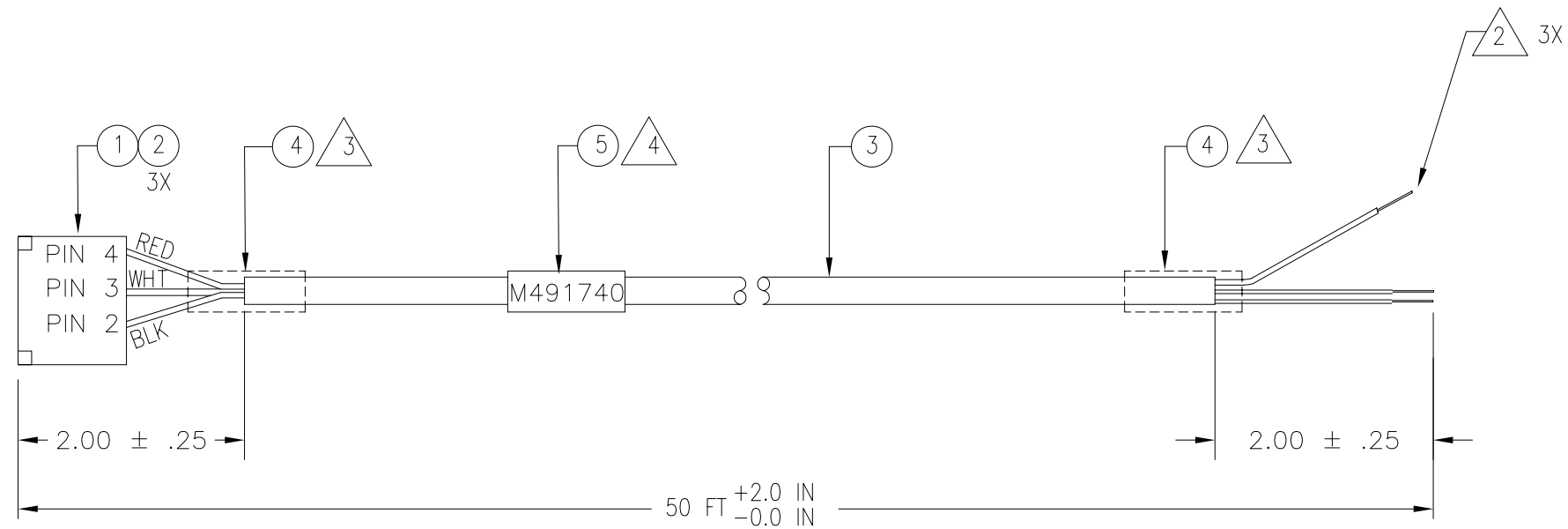

4	RED	TX
3	WHT	RX
2	BLK	GND

EXCEPT AS MAY OTHERWISE BE SPECIFIED BY CONTRACT, THIS DOCUMENT AND THE DATA DISCLOSED HEREIN AND HERewith, IS NOT TO BE USED, REPRODUCED OR DISCLOSED, IN WHOLE OR IN PART, TO ANYONE WITHOUT THE WRITTEN PERMISSION OF ADB SAFEGATE.

APPEND THE FOLLOWING DOCUMENTS WHEN CHANGING THIS DOCUMENT:	UNLESS OTHERWISE SPECIFIED: DIMENSIONS ARE IN INCHES TOLERANCES XX=±.010    ANGLES ±1/2° XXX=±.005    FRACTIONS=±.02 DO NOT SCALE DRAWING	DRAWN BY: PK	4/06/04	TITLE CABLE ASSEMBLY FREEZING RAIN DATA, AWOS	ADB SAFEGATE
	MATL SEE BILL OF MATERIALS	REVISED BY:			
	FINISH AS ISSUED	CHECKED BY:		SIZE C	DWG NO. M491740-003
	TREATMENT	DESIGN ENGINEER:		SCALE NONE	RELEASE DATE
		PROJECT MANAGER:		SHEET	1 OF 1
		APPROVALS	DATE		

NOTES: UNLESS OTHERWISE SPECIFIED;

REVISIONS			DWG NO. M491741-003	
REV	ECN	DESCRIPTION	DATE	APPROVED
A	5019	INITIAL RELEASE	4/2004	PK

1 MARK LABEL ITEM 4 (P/N M434026) WITH "M491702" AND CURRENT ECO AND REV LEVEL.  
ATTACH TO CABLE ASSEMBLY WHERE SHOWN.

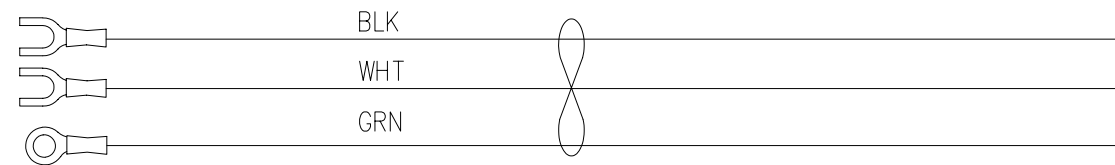
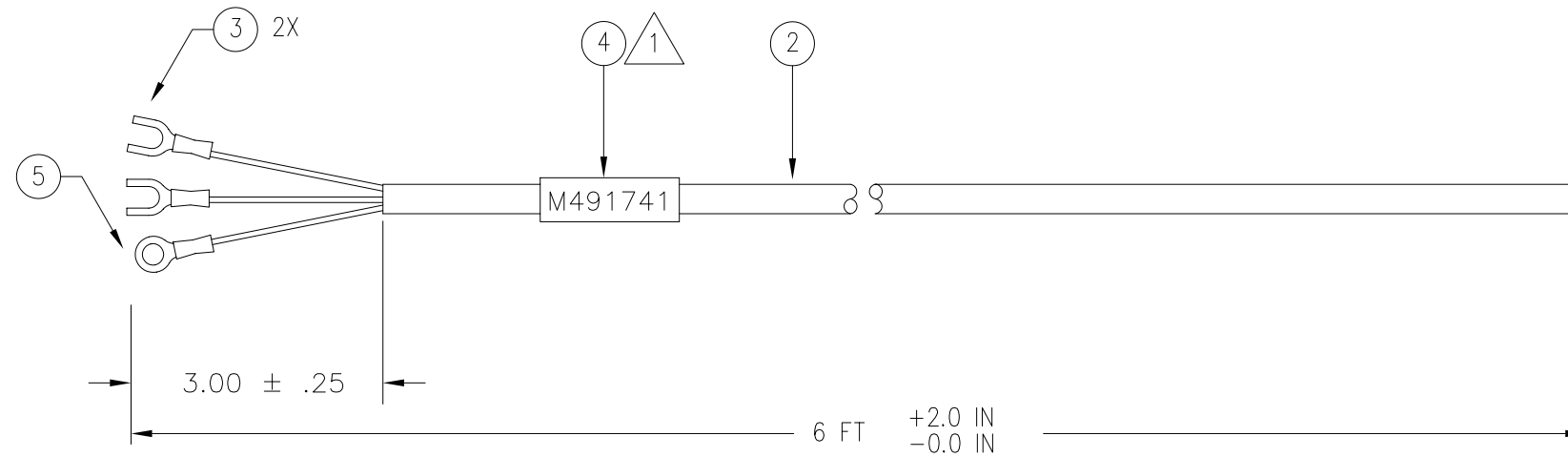

EXCEPT AS MAY OTHERWISE BE SPECIFIED BY CONTRACT, THIS DOCUMENT AND THE DATA DISCLOSED HEREIN AND HERewith, IS NOT TO BE USED, REPRODUCED OR DISCLOSED, IN WHOLE OR IN PART, TO ANYONE WITHOUT THE WRITTEN PERMISSION OF **ADB SAFEGATE**.

APPEND THE FOLLOWING DOCUMENTS WHEN CHANGING THIS DOCUMENT:	UNLESS OTHERWISE SPECIFIED: DIMENSIONS ARE IN INCHES TOLERANCES XX=±.010 ANGLES ±1/2" XXX=±.005 FRACTIONS=±.02 DO NOT SCALE DRAWING	DRAWN BY: PK	4/6/04	TITLE CABLE ASSEMBLY, FREEZING RAIN POWER, AWOS		
		REVISD BY:				
		MATL SEE BILL OF MATERIALS	CHECKED BY:		SIZE C	DWG NO. M491741-003
		FINISH AS ISSUED	DESIGN ENGINEER:			
TREATMENT	PROJECT MANAGER:		SCALE NONE	RELEASE DATE	SHEET 1 OF 1	
		APPROVALS	DATE			

# Optimizing Airside Operations From approach to take-off

SMARTER. BETTER. **NOW.**

  
**ADB  
SAFEGATE**  
[www.adbsafegate.com](http://www.adbsafegate.com)