



AXON Taxiway Inset Lights, 8-inch and 12-inch
FAA L-852A(L), L-852B(L), L-852C(L), L-852D(L),
L-852J(L), L-852K(L) Centerline; L-852S(L) Stop Bar;
Triple Line Centerline Narrow, Wide, Curved;
ICAO Centerline Narrow, Wide, Curved;
Runway Entrance Light (REL, RWSL);
Enhanced Rapid Exit;
ICAO Stop Bar;

User Manual

**ADB
SAFEGATE**

A.0 Disclaimer / Standard Warranty

CE certification

The equipment listed as CE certified means that the product complies with the essential requirements concerning safety and hygiene. The European directives that have been taken into consideration in the design are available on written request to ADB SAFEGATE.

ETL certification

The equipment listed as ETL certified means that the product complies with the essential requirements concerning safety and FAA Airfield regulations. The FAA directives that have been taken into consideration in the design are available on written request to ADB SAFEGATE.

All Products Guarantee

ADB SAFEGATE will correct by repair or replacement per the applicable guarantee above, at its option, equipment or parts which fail because of mechanical, electrical or physical defects, provided that the goods have been properly handled and stored prior to installation, properly installed and properly operated after installation, and provided further that Buyer gives ADB SAFEGATE written notice of such defects after delivery of the goods to Buyer. Refer to the Safety section for more information on Material Handling Precautions and Storage precautions that must be followed.

ADB SAFEGATE reserves the right to examine goods upon which a claim is made. Said goods must be presented in the same condition as when the defect therein was discovered. ADB SAFEGATE further reserves the right to require the return of such goods to establish any claim.

ADB SAFEGATE's obligation under this guarantee is limited to making repair or replacement within a reasonable time after receipt of such written notice and does not include any other costs such as the cost of removal of defective part, installation of repaired product, labor or consequential damages of any kind, the exclusive remedy being to require such new parts to be furnished.

ADB SAFEGATE's liability under no circumstances will exceed the contract price of goods claimed to be defective. Any returns under this guarantee are to be on a transportation charges prepaid basis. For products not manufactured by, but sold by ADB SAFEGATE, warranty is limited to that extended by the original manufacturer. This is ADB SAFEGATE's sole guarantee and warranty with respect to the goods; there are no express warranties or warranties of fitness for any particular purpose or any implied warranties of fitness for any particular purpose or any implied warranties other than those made expressly herein. All such warranties being expressly disclaimed.

Standard Products Guarantee

Products manufactured by ADB SAFEGATE are guaranteed against mechanical, electrical, and physical defects (excluding lamps) which may occur during proper and normal use for a period of two years from the date of ex-works delivery, and are guaranteed to be merchantable and fit for the ordinary purposes for which such products are made.



Note

See your applicable sales agreement for a complete warranty description.

Replaced or repaired equipment under warranty falls into the warranty of the original delivery. No new warranty period is started for these replaced or repaired products.

FAA Certified products manufactured by ADB SAFEGATE

ADB SAFEGATE L858 Airfield Guidance Signs are warranted against mechanical and physical defects in design or manufacture for a period of 2 years from date of installation, per FAA AC 150/5345-44 (applicable edition).

ADB SAFEGATE LED products (with the exception of obstruction lighting) are warranted against electrical defects in design or manufacture of the LED or LED specific circuitry for a period of 4 years from date of installation, per FAA EB67 (applicable edition). These FAA certified constant current (series) powered LED products must be installed, interfaced and powered with and through products certified under the FAA Airfield Lighting Equipment Program (ALECP) to be included in this 4 (four) year warranty. This includes, but is not limited to, interface with products such as Base Cans, Isolation Transformers, Connectors, Wiring, and Constant Current Regulators.



Note

See your sales order contract for a complete warranty description.

Replaced or repaired equipment under warranty falls into the warranty of the original delivery. No new warranty period is started for these replaced or repaired products.

Liability



WARNING

Use of the equipment in ways other than described in the catalog leaflet and the manual may result in personal injury, death, or property and equipment damage. Use this equipment only as described in the manual.

ADB SAFEGATE cannot be held responsible for injuries or damages resulting from non-standard, unintended uses of its equipment. The equipment is designed and intended only for the purpose described in the manual. Uses not described in the manual are considered unintended uses and may result in serious personal injury, death or property damage.

Unintended uses, includes the following actions:

- Making changes to equipment that have not been recommended or described in this manual or using parts that are not genuine ADB SAFEGATE replacement parts or accessories.
- Failing to make sure that auxiliary equipment complies with approval agency requirements, local codes, and all applicable safety standards if not in contradiction with the general rules.
- Using materials or auxiliary equipment that are inappropriate or incompatible with your ADB SAFEGATE equipment.
- Allowing unskilled personnel to perform any task on or with the equipment.

© ADB SAFEGATE SWEDEN AB

This manual or parts thereof may not be reproduced, stored in a retrieval system, or transmitted, in any form or by any means, electronic, mechanical, photocopying, recording, nor otherwise, without ADB SAFEGATE SWEDEN AB's prior written consent.

This manual could contain technical inaccuracies or typographical errors. ADB SAFEGATE SWEDEN AB reserves the right to revise this manual from time to time in the contents thereof without obligation of ADB SAFEGATE SWEDEN AB to notify any person of such revision or change. Details and values given in this manual are average values and have been compiled with care. They are not binding, however, and ADB SAFEGATE SWEDEN AB disclaims any liability for damages or detriments suffered as a result of reliance on the information given herein or the use of products, processes or equipment to which this manual refers. No warranty is made that the use of the information or of the products, processes or equipment to which this manual refers will not infringe any third party's patents or rights. The information given does not release the buyer from making their own experiments and tests.

© ADB SAFEGATE BV

This manual or parts thereof may not be reproduced, stored in a retrieval system, or transmitted, in any form or by any means, electronic, mechanical, photocopying, recording, nor otherwise, without ADB SAFEGATE BV's prior written consent.

This manual could contain technical inaccuracies or typographical errors. ADB SAFEGATE BV reserves the right to revise this manual from time to time in the contents thereof without obligation of ADB SAFEGATE BV to notify any person of such revision or change. Details and values given in this manual are average values and have been compiled with care. They are not binding, however, and ADB SAFEGATE BV disclaims any liability for damages or detriments suffered as a result of reliance on the information given herein or the use of products, processes or equipment to which this manual refers. No warranty is made that the use of the information or of the products, processes or equipment to which this manual refers will not infringe any third party's patents or rights. The information given does not release the buyer from making their own experiments and tests.

TABLE OF CONTENTS

1.0 Safety	1
1.1 Safety Messages	1
1.1.1 Introduction to Safety	2
1.1.2 Intended Use	2
1.1.3 Material Handling Precautions: Storage	3
1.1.4 Operation Safety	3
1.1.5 Maintenance Safety	3
1.1.6 Material Handling Precautions: Fasteners	4
1.1.7 Material Handling Precautions, ESD	4
2.0 About this Manual	5
2.1 How to work with the Manual	5
2.2 Abbreviations and Terms	6
3.0 Introduction	7
3.1 Product Information	8
3.2 Dimensions and Weight	12
4.0 Installation	15
4.1 Unpacking the Unit	15
4.2 Tools required	15
4.3 Installation	15
4.3.1 Installation Overview	16
4.3.2 INTEROPERABILITY	16
4.3.3 Typical L-868 Assembly	17
4.3.4 Safety Considerations	18
4.3.5 Photobiological safety	18
4.3.6 Verify Input Requirements and Equipment Needed	19
4.3.7 Unpacking the Unit	19
4.3.8 Inspect on delivery	20
4.4 Toe-in	20
4.5 Unpacking the Unit	21
4.6 Light Emission Directions	22
4.6.1 Definition of Light Emission Directions	22
5.0 Maintenance	23
5.1 Basic Maintenance Program	24
5.2 Recommended Maintenance Program for optimal Service Life	25
5.2.1 Recommendation	27
5.3 Workshop Maintenance	29
5.3.1 Opening a Light Fixture — disconnecting the Bottom Pan from the Top Cover	29
5.3.2 Closing a Light Fixture — connecting the Bottom Pan to the Top Cover	30
5.3.3 Replacing the Power Wire Harness	31
5.3.4 Replacing the Light Engine Assembly	33
5.3.5 Replacing the Prism and its Gasket	33
5.3.6 Replacing the Top Cover Assembly	34
5.3.7 Replacing the Bottom Cover Assembly	35
5.3.8 Replacing the secondary Cable — SJO cord set	36
5.3.9 Replacing the secondary Cable — Style-6 cord set	37
5.3.10 Resetting the Fail-open Converter	38
5.3.11 Checking the Light Fixture for Water-tightness	39
6.0 Ordering Codes	41
6.1 Ordering Code L852-A/B/C/D/J/K-(L), LED Taxiway Centerline, Lead-on/Exit, Apron Lead-in (FAA)	42
6.2 Ordering Code LED Taxiway Centerline (ICAO)	44
6.3 Ordering Code LED Triple Line Taxiway Centerline Light	46
6.4 Ordering Code LED Stopbar (ICAO)	48

6.5 Ordering Code LED L-852S(L) LED Stop Bar (FAA)	50
6.6 Ordering Code LED Runway Status L-850T(L), Takeoff/ Hold, Runway Intersection (THL/RIL) and Runway Entry Light (REL) (FAA)	51
7.0 Spare Parts	53
7.1 Versions and Exploded View	53
7.2 Spare Part Illustrations	55
7.3 Spare Parts — Taxiway Centerline Light FAA	58
7.4 Spare Parts — Taxiway Centerline Light ICAO	62
7.5 Spare Parts — Stop Bar Light FAA	65
7.6 Spare Parts — Stop Bar Light ICAO	67
7.7 Spare Parts — Taxiway Status, Takeoff/ Hold, Intersection and Entry Light	70
7.8 Spare Parts — Triple Line Taxiway Centerline Light	72
A.0 Winter Operations: Snow Plowing Guidelines for inset Lights	73
B.0 INTEROPERABILITY	77
C.0 POWER TABLE	81
D.0 CABLE LOSS	83
E.0 SUPPORT	85
E.1 ADB SAFEGATE Website	85
E.2 Recycling	85
E.2.1 Local Authority Recycling	85
E.2.2 ADB SAFEGATE Recycling	86

List of Figures

Figure 1: 8- and 12-inch fixtures	7
Figure 2: 8-inch Taxiway Lights	12
Figure 3: 12-inch Taxiway Lights	13
Figure 4: Installation on 8" shallow base	16
Figure 5: Diagram of the Fixture Installed in a 1-Piece Base Can	17
Figure 6: Anti-vibration washer example	17
Figure 7: Toe-in	20
Figure 8: Light emission directions	22
Figure 9: Preventive Maintenance	26
Figure 10: Visual Inspection Interval	27
Figure 11: Power harness replacement	31
Figure 12: LED bracket removal	31
Figure 13: Light engine removal	34
Figure 14: Sequence	34
Figure 15: Light engine removal	35
Figure 16: Secondary cable replacement	36
Figure 17: Secondary cable replacement	37
Figure 18: Converter, 1-connector	38
Figure 19: Converter, 2-connector	39
Figure 20: Pressure-relief screw removal	39
Figure 21: Taxiway Insets, cord set options	53
Figure 22: 8-inch (left) and 12 inch(right)	54
Figure 23: Top Cover Assemblies, 8-inch	55
Figure 24: Top Cover Assemblies, 12-inch	55
Figure 25: Bottom Pan gasket, 8-inch and 12-inch	55
Figure 26: Bottom Pan assembly, 8-inch	55
Figure 27: LED light engines wire harness, package of 10	56
Figure 28: Light Engine assembly for 8-inch and 12-inch	56
Figure 29: Prism spares	56
Figure 30: Ground lugs, package of 5	56
Figure 31: Style-1 Cord Set Cable Clamp, package of 5	56
Figure 32: Mounting screws, package of 100	56
Figure 33: Pressure release screws, package of 5	57
Figure 34: Fig. 1 — Snowplow blade with well aligned segments	74
Figure 35: Fig. 2 — Snowplow blade with wear and steps between segments	74

Figure 36: Fig. 3 — Snowplow blade without clearance	75
Figure 37: Fig. 4 — Snowplow with support wheels	75
Figure 38: Fig. 5 — Snowplow without support wheels	75

List of Tables

Table 1: Suggested Tools and Materials for Installation and Repair	19
Table 2: Interoperability matrix — 12 inch	77
Table 3: Interoperability matrix — 8 inch	78

1.0 Safety

Introduction to Safety







This section contains general safety instructions for installing and using ADB SAFEGATE equipment. Some safety instructions may not apply to the equipment in this manual. Task- and equipment-specific warnings are included in other sections of this manual where appropriate.

1.1 Safety Messages

HAZARD Icons used in the manual

For all HAZARD symbols in use, see the Safety section. All symbols must comply with ISO and ANSI standards.

Carefully read and observe all safety instructions in this manual, which alert you to safety hazards and conditions that may result in personal injury, death or property and equipment damage and are accompanied by the symbol shown below.

	<p>WARNING Failure to observe a warning may result in personal injury, death or equipment damage.</p>
	<p>DANGER - Risk of electrical shock or ARC FLASH Disconnect equipment from line voltage. Failure to observe this warning may result in personal injury, death, or equipment damage. ARC Flash may cause blindness, severe burns or death.</p>
	<p>WARNING - Wear personal protective equipment Failure to observe may result in serious injury.</p>
	<p>WARNING - Do not touch Failure to observe this warning may result in personal injury, death, or equipment damage.</p>
	<p>CAUTION Failure to observe a caution may result in equipment damage.</p>
	<p>ELECTROSTATIC SENSITIVE DEVICES This equipment may contain electrostatic devices.</p>

Qualified Personnel

	<p>Important Information The term qualified personnel is defined here as individuals who thoroughly understand the equipment and its safe operation, maintenance and repair. Qualified personnel are physically capable of performing the required tasks, familiar with all relevant safety rules and regulations and have been trained to safely install, operate, maintain and repair the equipment. It is the responsibility of the company operating this equipment to ensure that its personnel meet these requirements. Always use required personal protective equipment (PPE) and follow safe electrical work practice.</p>
---	---

1.1.1 Introduction to Safety



CAUTION

Unsafe Equipment Use

This equipment may contain electrostatic devices, hazardous voltages and sharp edges on components

- Read installation instructions in their entirety before starting installation.
- Become familiar with the general safety instructions in this section of the manual before installing, operating, maintaining or repairing this equipment.
- Read and carefully follow the instructions throughout this manual for performing specific tasks and working with specific equipment.
- Make this manual available to personnel installing, operating, maintaining or repairing this equipment.
- Follow all applicable safety procedures required by your company, industry standards and government or other regulatory agencies.
- Install all electrical connections to local code.
- Use only electrical wire of sufficient gauge and insulation to handle the rated current demand. All wiring must meet local codes.
- Route electrical wiring along a protected path. Make sure they will not be damaged by moving equipment.
- Protect components from damage, wear, and harsh environment conditions.
- Allow ample room for maintenance, panel accessibility, and cover removal.
- Protect equipment with safety devices as specified by applicable safety regulations
- If safety devices must be removed for installation, install them immediately after the work is completed and check them for proper functioning prior to returning power to the circuit.

Failure to follow this instruction can result in serious injury or equipment damage

Additional Reference Materials



Important Information

- IEC - International Standards and Conformity Assessment for all electrical, electronic and related technologies.
- IEC 60364 - Electrical Installations in Buildings.
- FAA Advisory: AC 150/5340-26 (current edition), Maintenance of Airport Visual Aid Facilities.
- Maintenance personnel must refer to the maintenance procedure described in the ICAO Airport Services Manual, Part 9.
- ANSI/NFPA 79, Electrical Standards for Metalworking Machine Tools.
- National and local electrical codes and standards.

1.1.2 Intended Use



CAUTION

Use this equipment as intended by the manufacturer

This equipment is designed to perform a specific function, do not use this equipment for other purposes

- Using this equipment in ways other than described in this manual may result in personal injury, death or property and equipment damage. Use this equipment only as described in this manual.

Failure to follow this instruction can result in serious injury or equipment damage

1.1.3 Material Handling Precautions: Storage



CAUTION

Improper Storage

Store this equipment properly

- If equipment is to be stored prior to installation, it must be protected from the weather and kept free of condensation and dust.

Failure to follow this instruction can result in equipment damage

1.1.4 Operation Safety



CAUTION

Improper Operation

Do Not Operate this equipment other than as specified by the manufacturer

- Only qualified personnel, physically capable of operating the equipment and with no impairments in their judgment or reaction times, should operate this equipment.
- Read all system component manuals before operating this equipment. A thorough understanding of system components and their operation will help you operate the system safely and efficiently.
- Before starting this equipment, check all safety interlocks, fire-detection systems, and protective devices such as panels and covers. Make sure all devices are fully functional. Do not operate the system if these devices are not working properly. Do not deactivate or bypass automatic safety interlocks or locked-out electrical disconnects or pneumatic valves.
- Protect equipment with safety devices as specified by applicable safety regulations.
- If safety devices must be removed for installation, install them immediately after the work is completed and check them for proper functioning.
- Route electrical wiring along a protected path. Make sure they will not be damaged by moving equipment.
- Never operate equipment with a known malfunction.
- Do not attempt to operate or service electrical equipment if standing water is present.
- Use this equipment only in the environments for which it is rated. Do not operate this equipment in humid, flammable, or explosive environments unless it has been rated for safe operation in these environments.
- Never touch exposed electrical connections on equipment while the power is ON.

Failure to follow these instructions can result in equipment damage

1.1.5 Maintenance Safety



DANGER

Electric Shock Hazard

This equipment may contain electrostatic devices

- Do not operate a system that contains malfunctioning components. If a component malfunctions, turn the system OFF immediately.
- Disconnect and lock out electrical power.
- Allow only qualified personnel to make repairs. Repair or replace the malfunctioning component according to instructions provided in its manual.

Failure to follow these instructions can result in death or equipment damage

1.1.6 Material Handling Precautions: Fasteners



DANGER

Foreign Object Damage - FOD

This equipment may contain fasteners that may come loose - torque properly.

- Only use fasteners of the same type as the one originally supplied with the equipment.
- Use of incorrect combination of gaskets, bolts and nuts can create severe damages to the product installation and create safety risk .
- You need to know what base the light fixture will be installed in, in order to chose the correct gasket, bolts and nuts.
- Bolt type, length, and torque value are determined by type of base, height of spacers used, and clamp force required in FAA Engineering Brief No 83 (latest revision).
- Due to the risk of bolts vibrating loose, do not use any type of washer with the fixing bolts (such as split lock washers) other than an anti-vibration washer. Anti-vibration washers as defined in FAA EB 83 (latest edition) must be used. For installations other than FAA, use the base can manufacturer's recommendations.
- Always tighten the fasteners to the recommended torque. Use a calibrated torque wrench and apply the recommended adhesive type.
- Obey the instructions of the adhesives necessary for the fasteners.

Failure to follow these warnings may cause the fasteners to loosen, damage the equipment, potentially to loosen the equipment. This can lead to a highly dangerous situation of FOD, with potential lethal consequences.



Note

To minimize the risk of errors, the ADB SAFEGATE Sales Representative will have information on which gasket goes with which base. This information is also provided in the product Data sheets, the User Manuals and the Spare Part Lists.



CAUTION

Use of incorrect combination of gaskets, bolts and nuts can create severe damages to the product installation and create multiple safety risks.

To obtain a safe and watertight installation the O-ring and retaining bolt stated in the document must be used.

You need to know what base the light fixture will be installed in, in order to choose the correct gasket, bolts and nuts.

Failure to follow these cautions can result in equipment damage or aircraft FOD.

1.1.7 Material Handling Precautions, ESD



CAUTION

Electrostatic Sensitive Devices

This equipment may contain electrostatic devices

- Protect from electrostatic discharge.
- Electronic modules and components should be touched only when this is unavoidable e.g. soldering, replacement.
- Before touching any component of the cabinet you shall bring your body to the same potential as the cabinet by touching a conductive earthed part of the cabinet.
- Electronic modules or components must not be brought in contact with highly insulating materials such as plastic sheets, synthetic fiber clothing. They must be laid down on conductive surfaces.
- The tip of the soldering iron must be grounded.
- Electronic modules and components must be stored and transported in conductive packing.

Failure to follow this instruction can result in equipment damage

2.0 About this Manual

This document includes AXON taxiway inset light fixture information with a focus on safety, installation and maintenance procedures.

For more information, see www.adbsafegate.com.



Note

It is very important to read this document before any work is started.

This manual covers the following 8- and 12-inch fixtures:

- L-852A(L) Taxiway Centerline (TA)
- L-852B(L) Taxiway Centerline (TB)
- L-852C(L) Taxiway Centerline (TC)
- L-852D(L) Taxiway Centerline (TD)
- L-852J(L) Taxiway Centerline (TJ)
- L-852K(L) Taxiway Centerline (TK)
- L-852S(L) FAA Stop Bar (SB)
- Runway Entrance Light (TS)
- ICAO Taxiway Centerline Narrow Beam (TC)
- ICAO Taxiway Centerline Curved Beam (TK)
- ICAO Taxiway Centerline Enhanced Wide Beam (TR)
- ICAO Taxiway Centerline Wide Beam (TW)
- ICAO Stop Bar (SB)
- Triple Line Taxiway Centerline Light (3C, 3N, 3W)

2.1 How to work with the Manual

- Familiarize yourself with the structure and content.
- Carry out the actions completely and in the given sequence.

2.2 Abbreviations and Terms

This document may include the abbreviations and terms listed below.

Abbreviation and term	Description
CAA	Civil Aviation Authority
CCR	Constant Current Regulator
FAA	Federal Aviation Administration
ICAO	International Civil Aviation Organization
IEC	International Electrotechnical Committee
ILCMS	Individual Light Control and Monitoring System
LED	Light Emitting Diode
NATO	North Atlantic Treaty Organization
STAC	Service Technique de l'Aviation Civile (France)
STANAG	Standardization Agreement (NATO)

3.0 Introduction

The all-in-one solution

The 8-inch and 12-inch ranges are bi- or unidirectional low protrusion light-emitting diode (LED) inset light fixtures, available in multiple versions:

Non-MON	Basic operation providing power only
MON (Fail-open)	A LED light fixture with integrated fail open technology for CCR monitoring compatibility
EQ	Fixture with integrated ILCMS remote utilizing orthogonal frequency-division multiplexing (OFDM) technology providing superior communication interfacing with LINC 360 System.



NOTICE

All our light fixtures are equipped with failed LED detection monitoring as required by FAA Engineering Brief 67.

Figure 1: 8- and 12-inch fixtures

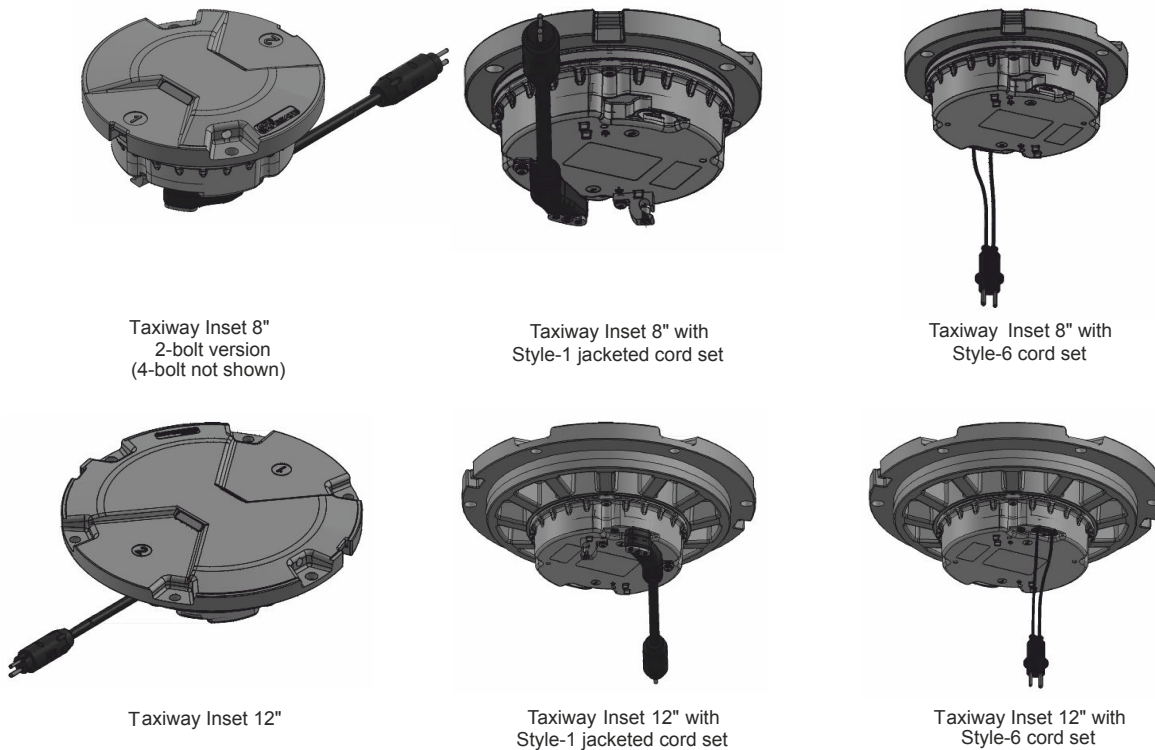

Note

EQ light fixtures are not fail-open light fixtures. The monitoring as well as the control functionality is handled by the ILCMS system.

3.1 Product Information

Compliance and Standards

Compliance	Description	Application: Reference DS-XXXX:	ICAO	FAA SB	ICAO	FAA TA-	3C-3N-3W	TS
			SB		TC-TK- TR-TW	TB-TC-TD- TJ-TK		
			5049	5050	5051	5052	5054	5070
FAA	AC 150/5345-46 and the FAA Engineering Brief No. 67			X		X		X
ICAO	Annex 14 Volume 1		X		X			
EASA	CS-ADR-DSN		X		X			
Australia	MOS 139		X		X			
Canada	TP 312		X		X			
IEC	61827		X		X		X	
NATO	STANAG 3316		X		X			
STAC	PRO/STAC/SE/VIS		X		X			
UK	CAP 168		X		X			
CE			X	X	X	X	X	X

Applications TA-TB-TC-TD-TJ-TK

FAA and UFC

- L-852A(L), L-852B(L), L-852C(L), L-852D(L), L-852J(L), L-852K(L)
Taxiway Centerline
- Lead-on/Exit
- Apron Lead-in

Applications TC-TK-TR-TW

ICAO

- Taxiway centerline
- Lead-in
- Intermediate holding position

Applications 3C-3N-3W

ICAO

- Triple Line Taxiway Centerline Light

Applications ICAO SB

ICAO

- Stop bar

Applications FAA SB

FAA and UFC

- L-852S(L) Stop bar

Applications RS/TS

FAA Runway Status Light (RWSL) Applications

- L-850T(L) THL Runway Takeoff/Hold Light
- L-850T(L) RIL Runway Intersection Light
- REL Runway Entry Light



Note

Refer to Runway manual UM-5055 for information on L-850T(L).

Features and Benefits

Efficiency

- EQ has an internal ILCMS remote for use with the LINC 360 system providing high data capacity and resisting degradation from various types or radio effects to provide a superior communication platform
- Precision aimed optics enhancing photometric performance and complementing extended LED life
- Reduced bottom pan profile allowing for very shallow base can installation
- LEDs pulse width modulated (PWM) at 400 Hz optimizing LED performance and eliminating perceptible flicker to a moving human observer throughout the range of brightness steps
- Operates at all steps of constant current regulator technologies designed in compliance with IEC or FAA requirements
- Fully dimmable lights, conforming to the dimming curve of traditional halogen lights
- Low protrusion, high-intensity, Style 3 (≤ 6.35 mm) inset light fixtures
- No negative slope in front of the prisms

Sustainability

- Fully encapsulated all-in-one universal power supplies for Runway, Taxiway, Approach and Omni inset families
- Latest generation LEDs providing a long-lasting light source with high efficiency and low power consumption
- Reinforced top cover substantially exceeding standards to improve durability and longevity
- One single family of fixtures covering all runway, taxiway and approach applications
- IP68 rated enclosure designed for harsh environments; all fastenings are stainless steel
- Reinforced prism available as an option
- Compatible with existing infrastructure allowing for direct replacement of existing LED inset fixtures

Safety

- Improved mechanical design to strengthen and consolidate components, improving the customer maintenance experience
- Fail-open option for compatibility with legacy monitoring systems and optimization of advanced control/ monitoring systems
- Failed-LED Detection as required by Engineering Brief 67D
- Robust lightning protection complying with ANSI/IEEE C62.41-1991; Location Category C2 as required by FAA Eng. Brief 67. Category C2 is defined as a 1.2/50 μ S – 8/20 μ S combination wave, with a peak voltage of 10,000 V and a peak current of 5,000 A

Power Supply Options

- Non-Monitored — Power only
- Monitored — integrated Fail-open technology
- EQ with integrated ILCMS with OFDM technology for use with LINC 360 system.

Maintenance and Installation

The light fixture can be installed on a 8-inch and 12-inch base. Gaskets are sold separately. Check what gasket and bolts to order depending on base and installation.

Operating Conditions

Operating temperature	-60 °C to +55 °C / -76 °F to +131 °F
Storage temperature	-60 °C to +80 °C / -76 °F to +176 °F
Humidity	Up to 100%

3.2 Dimensions and Weight

The weight and measurement depends on version of the light fixture.

Version	Weight	Dimension
ICAO SB-TC-TK-TR-TW 3C-3N-3W; FAA SB-TA-TB-TC-TD-TJ-TK	3 kg / 6.6 lb (8 in)	203 mm / 8 in
ICAO SB-TC-TK-TR-TW-3C-3N-3W; FAA SB-TA-TB-TC-TD-TJ-TK	6.8 kg / 15 lb (12 in)	305 mm / 12 in

Figure 2: 8-inch Taxiway Lights

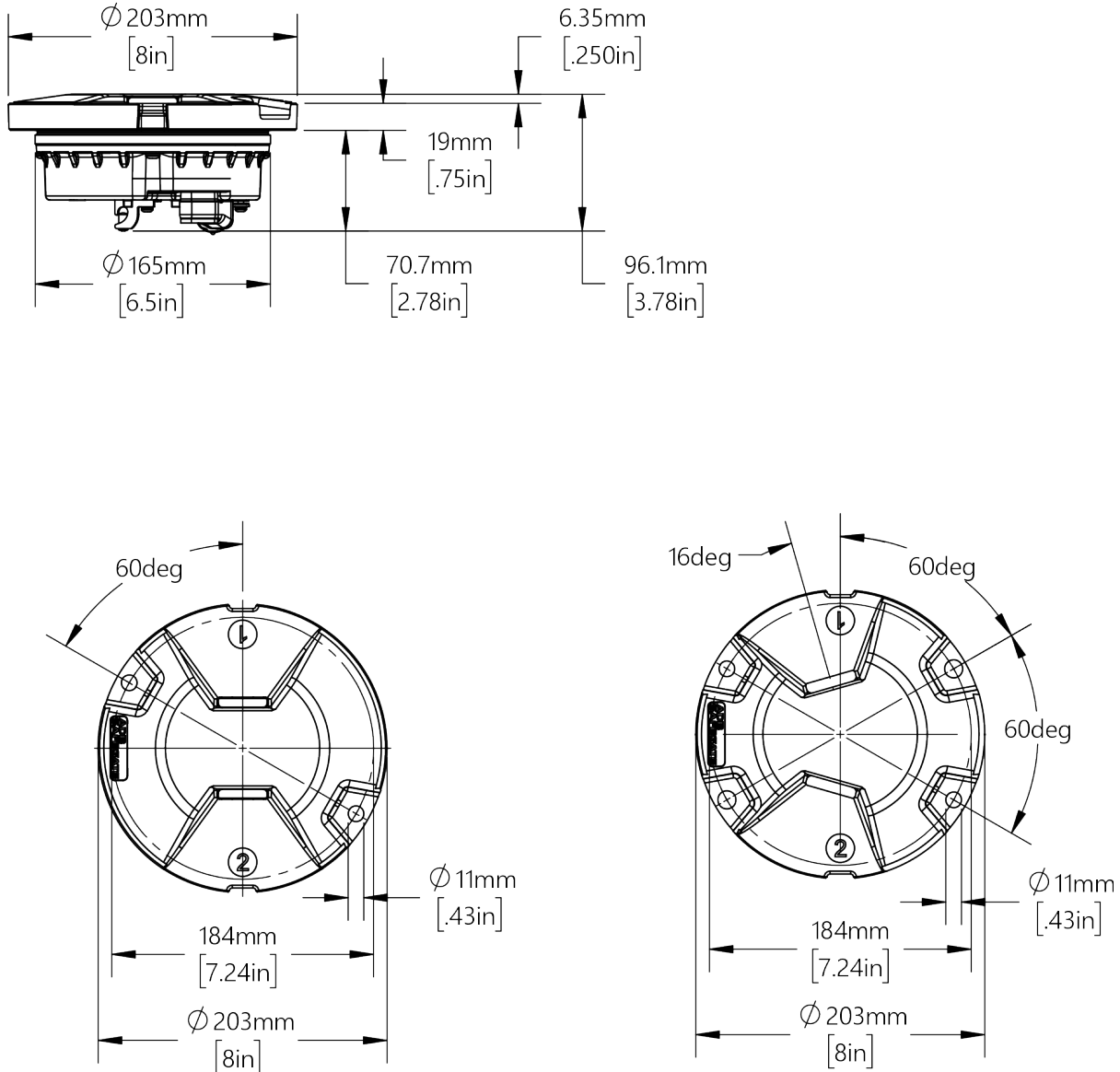
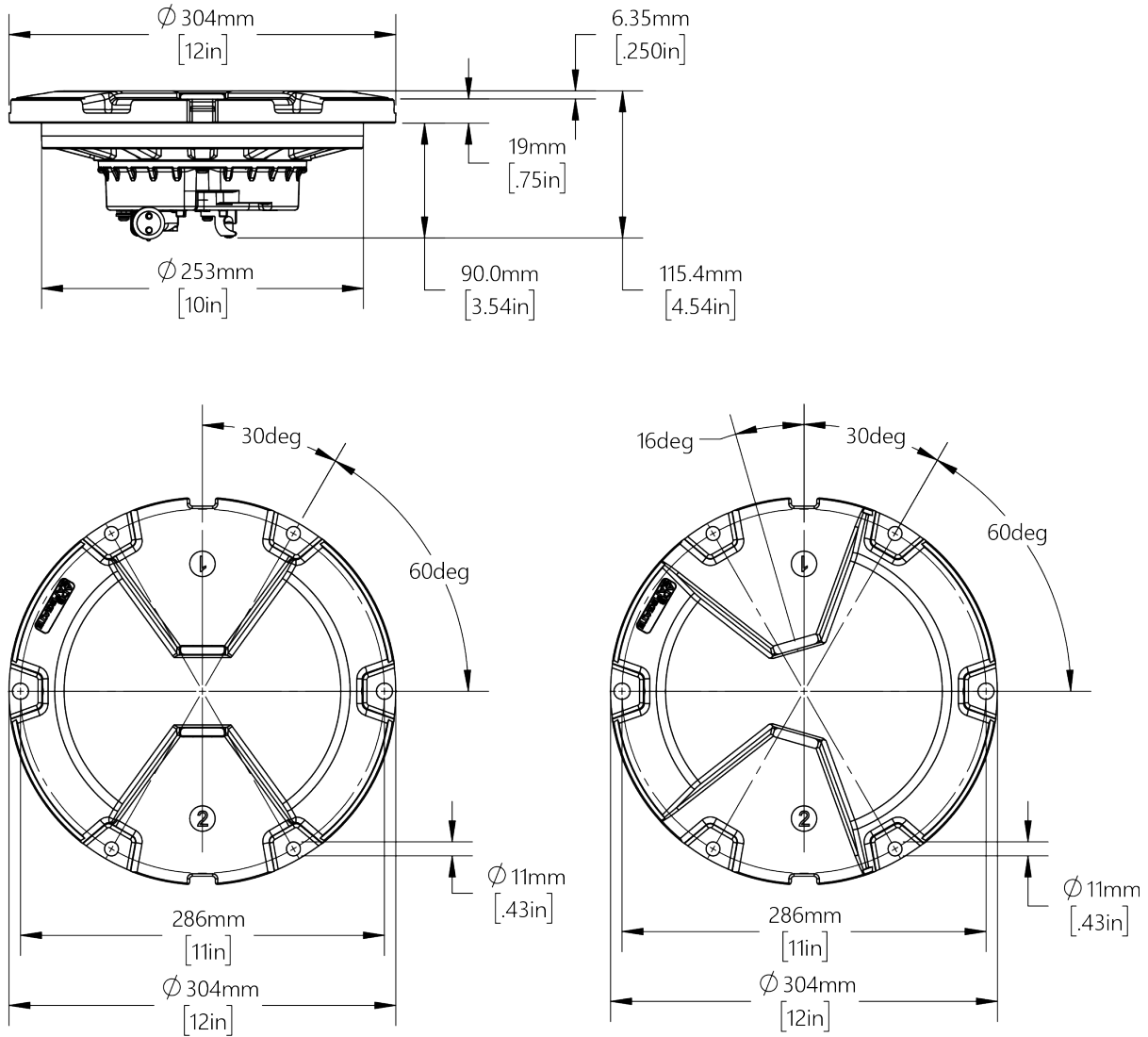

Figure 3: 12-inch Taxiway Lights



4.0 Installation

Install the inset light fixture in a base provided by ADB SAFEGATE as follows:



Note

If the inset light fixture is to be installed on another type of base or adapter ring not provided by ADB SAFEGATE, contact ADB SAFEGATE.



CAUTION

Use of incorrect combination of gaskets, bolts and nuts can create severe damages to the product installation and create multiple safety risks.

To obtain a safe and watertight installation the O-ring and retaining bolt stated in the document must be used.

You need to know what base the light fixture will be installed in, in order to choose the correct gasket, bolts and nuts.

4.1 Unpacking the Unit

To reduce the possibility of damaging the light assembly, unpack the light fixtures at the installation site. If damage to any equipment is noted, file a claim form with the carrier immediately.

When receiving the light fixture, open the box and verify that the characteristics of the light fixture correspond to the design requirements, such as type, color etc. When installing a light fixture where the control and monitoring function is to be activated at a later stage, make sure to register product information, such as PID/SN and position of the light fixture in, for example, a site documentation table. The information is required for remote activation and administration of control and monitoring functionality from a substation.

4.2 Tools required

The following tools are recommended for installation.

- Screwdriver or drill/driver with 21 mm (9/16-inch) socket *
- Torque wrench with 21 mm (9/16-inch) socket
- Large flat head screwdriver to lift edge of fixture to reposition if necessary
- One T20 Torx key
- One brush or cloth



Note

Provided that the base intended to receive the light fixture has been properly installed, no other specific tool is required.

4.3 Installation



WARNING

Read the instructions in their entirety before starting installation.

This section provides instructions for installing the in-pavement lights. Refer to airport project plans and specifications for specific installation instructions. The installation must conform to the applicable sections of the National Electric Code and local codes.

* **Do not use an impact wrench.**

4.3.1 Installation Overview

On a shallow base.

The 8" dia. base is secured in the pavement by means of resin. Correct positioning and leveling are obtained with a jig with sighting telescope. Wires between the light and the series transformer are installed either in saw cuts in the pavement filled with resin or in pipes in the lower concrete layers. Mounting on existing or new, larger diameter bases, is made possible by means of dedicated adapter rings.

Figure 4: Installation on 8" shallow base

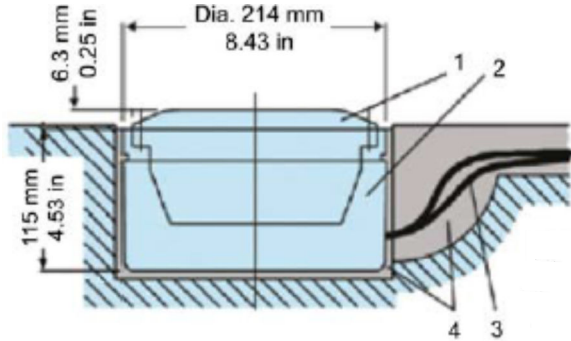

On a FAA L-868B size B steel base.

The 8" dia. light is mounted in an 8" to 12" dia. snow plow or adapter ring bolted onto the base. The 12" fixture is directly mounted without a separate ring. The bases are interconnected by means of conduits protecting the cables. See FAA AC 150/5340-30 for additional design guidance on deep base cans. The series transformer is installed under the light or in a separate pit. See data sheet A.05.120 or DS2012 for more information on base cans.

4.3.2 INTEROPERABILITY

Top cover versions



Note

Please check interoperability matrix for information on torque values and compatibility towards different bases.

4.3.3 Typical L-868 Assembly

Figure 5: Diagram of the Fixture Installed in a 1-Piece Base Can

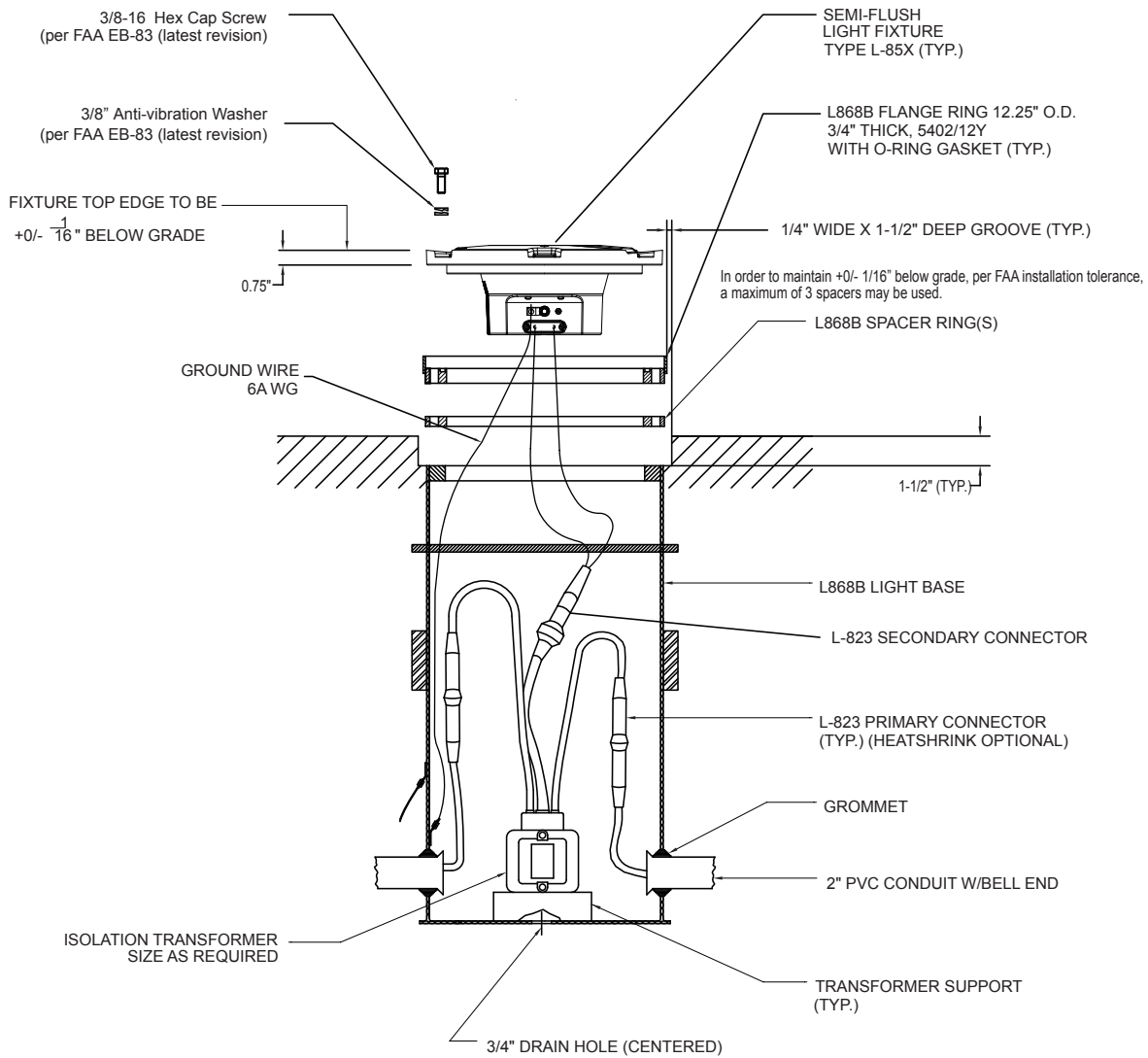

1. Torque according to: FAA EB-83 (latest revision).

Figure 6: Anti-vibration washer example

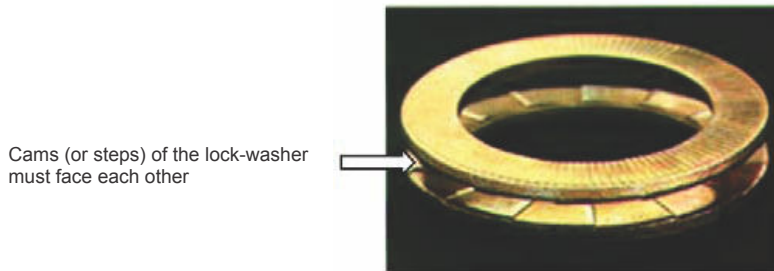



CAUTION

Per FAA AC 150/5340-30, Chapter 10, and FAA Engineering Brief No 83 (latest revision), it is extremely important that other types of washers, such as split washers, must not be used. Failure to use properly installed anti-vibration lock washers will cause mounting bolts to become loose. The cams (or steps) of each half of the lock washer must face each other.

4.3.4 Safety Considerations

Read the installation section of all system component manuals before starting these steps. A thorough understanding of system components and their requirements will promote safe and efficient installation. See FAA AC 150/5340-30, Design and Installation Details for Airport Visual Aids, and site plans and specifications for field installation of runway and taxiway in-pavement lights.



DANGER

Failure to follow these safety procedures can result in personal injury or death.

- Allow only qualified personnel to install ADB SAFEGATE and auxiliary equipment. Use only approved equipment. Using unapproved equipment in an approved system may void FAA approvals. Observe and follow the safety instructions in this document and all other related documentation.
 - Make sure all equipment is rated and approved for the environment where it is being used.
 - Follow all instructions for installing components and accessories.
 - Install all electrical connections in compliance with local and national codes and regulations.
 - Use only electrical wire of sufficient gauge and insulation to handle the rated current demand. All wiring must meet local and national codes.
 - Route electrical wiring along a protected path. Make sure it will not be damaged by moving equipment.
 - Protect components from damage, wear and harsh environmental conditions.
 - Allow ample clearance for maintenance, panel accessibility and cover removal.
 - Protect equipment with safety devices as specified by applicable safety regulations.
 - If safety devices must be removed for installation, reinstall them immediately after the work is completed and check them for proper functioning.
 - The cord set must be protected prior to installation.
-

4.3.5 Photobiological safety



CAUTION

Photobiological safety conforming with IEC 62471

RISK GROUP 0 or 1: Optical radiation emitted from LED lights may be harmful to the eyes. Do not stare with at the light source with bare eyes at a fixture operating at high intensity. Use protection goggles or similar protection method.

Goggles with a transmission factor not higher than 5% in the 400-530 nm band have been tested and provide adequate protection.

4.3.6 Verify Input Requirements and Equipment Needed

The In-pavement light fixture is designed for connection to a 6.6A or 20A series lighting circuit via an L-830 (60 Hz) or L-831 (50 Hz) isolation transformer.

Make sure you have the necessary tools and materials ready for installation (not supplied). Also consider other tools that might be needed based on site-specific conditions.

Table 1: Suggested Tools and Materials for Installation and Repair

Qty.	Description	Qty.	Description
1	Torque wrench	1	Set of screwdrivers, one with 3/8" (9.525mm) minimum blade width
1	Alignment jig		
1	Diamond-faced core drill	As needed	Silicone grease
1	Diamond-faced saw, 3/8" (9.525mm) thick	As needed	Joint sealing filler
1	Crimping tool	1	Pressure test fitting assembly
1	Small water suction pump	As needed	Dow Corning Molykote® 3452 or equal (P/N 67A0095) - used on top cover prism seal
2	Eyebolts, 3/8 inch (9.525mm) diameter		
1	Lifting rod, 16 inches (406mm) long	As needed	Novagard® Silicone Versilube® G322L™ (P/N 67A0009) - used on O-ring between top cover and inner pan assembly; also may be applied to four nipples of inner pan assembly to install optical assembly
1 or 2	L-830 / L-831 isolation transformer		
1	Set of fiber brushes		
1	Set of socket wrenches, 1/2" (12.7mm) drive		

4.3.7 Unpacking the Unit

To reduce the possibility of damaging the light assembly, unpack the light fixtures at the installation site. If damage to any equipment is noted, file a claim form with the carrier immediately.

When receiving the light fixture, open the box and verify that the characteristics of the light fixture correspond to the design requirements, such as type, color etc. When installing a light fixture where the control and monitoring function is to be activated at a later stage, make sure to register product information, such as PID/SN and position of the light fixture in, for example, a site documentation table. The information is required for remote activation and administration of control and monitoring functionality from a substation.

4.3.8 Inspect on delivery

1. Inspect all packings for visible damage.
2. Open every damaged box and inspect the contents for damage.
3. Immediately fill a claim form with the carrier if any fixture is damaged.
4. Store the fixture in its original packing in a protected area.



Note

If damage to any equipment is noted, file a claim form with the carrier immediately.



WARNING

Do not damage the cable insulation.



CAUTION

Do not unpack the fixture before it is at the installation site to avoid damage due to transportation and handling.

4.4 Toe-in

Toe-in of light fixtures can be achieved in two ways:

1. By installing the light fixture in taxiway parallel bases and use light fixtures with built in toe-in.
2. By installing the light fixture in bases installed at an angle relative to the taxiway and use light fixtures with no built in toe-in.

If bases which are installed at an angle are used, provided that they are installed correctly, straight light fixtures (i.e. with no toe-in) should be used.

The following chapter only regards the case where light fixtures are installed in runway/taxiway parallel bases, i.e. where no toe-in is achieved by angled bases.

There are two major categories regarding the toe-in in taxiway light fixtures:

Straight light fixtures	These light fixtures have a straight light beam
Light fixtures with mechanical toeing	These light fixtures have a top cover with the toe-in cast in place at an appropriate angle

Figure 7: Toe-in

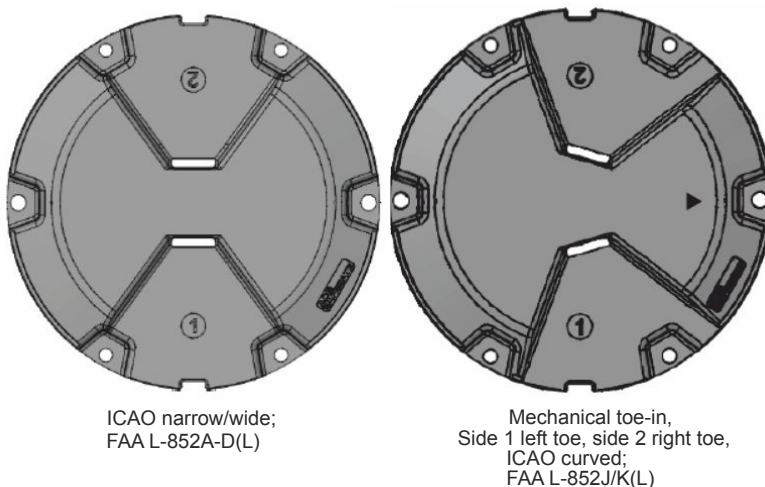

4.5 Unpacking the Unit

To reduce the possibility of damaging the light assembly, unpack the light fixtures at the installation site. If damage to any equipment is noted, file a claim form with the carrier immediately.







When receiving the light fixture, open the box and verify that the characteristics of the light fixture correspond to the design requirements, such as type, color etc. When installing a light fixture where the control and monitoring function is to be activated at a later stage, make sure to register product information, such as PID/SN and position of the light fixture in, for example, a site documentation table. The information is required for remote activation and administration of control and monitoring functionality from a substation.

4.6 Light Emission Directions

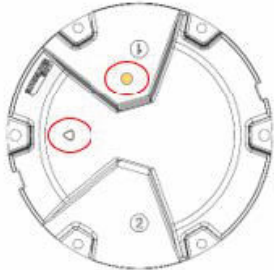
4.6.1 Definition of Light Emission Directions

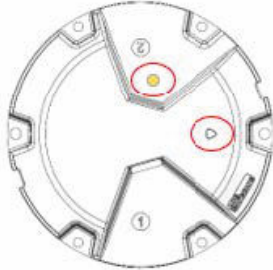
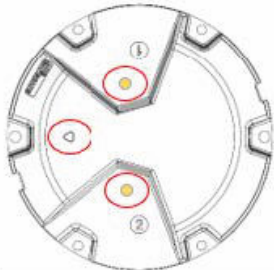
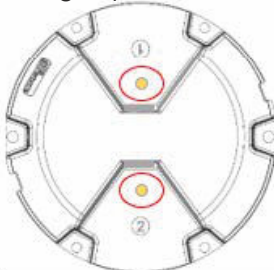
The color of the emitted light is indicated with a painted dot on the top cover in front of the prism. Toe-in is per the stamped directional arrow.

Figure 8: Light emission directions

<p>Left toe</p> 	<p>Straight (uni-directional)</p> 	<p>Right toe</p> 
<p>Curved</p> 	<p>Straight (bi-directional)</p> 	
<p>Color</p>	<p>Color code</p>	
<p>W</p>	<p>White</p>	
<p>Y</p>	<p>Yellow</p>	
<p>G or F</p>	<p>Green</p>	
<p>R</p>	<p>Red</p>	
<p>B</p>	<p>Blue</p>	

5.0 Maintenance

This section describes different steps for maintenance of the light fixture.

Before you start, make sure you have read and understand [Safety instructions](#).

Find out the location of the light unit that needs maintenance. If the purpose is to replace an existing light unit with new one, make sure that corresponding unit is available. Find the type information on the identification tag with details of name.

Spare parts are available, if required. For more information, see www.adbsafegate.com and the Spare Parts List document, or contact ADB SAFEGATE for assistance.



CAUTION

Use of incorrect combination of gaskets, bolts and nuts can create severe damages to the product installation and create multiple safety risks.

You need to know what base the light fixture will be installed in, in order to chose the correct gasket, bolts and nuts.

Failure to follow these cautions can result in equipment damage or aircraft FOD. For more information, see [INTEROPERABILITY](#).



CAUTION

When a light fixture has been removed from its base, the base must be either fitted with a cover or a spare light fixture put in its place. It is recommended that only authorized personnel disassemble fittings with prior agreement from ADB SAFEGATE.

5.1 Basic Maintenance Program

It is important to understand that even though a LED fixture requires substantially lower maintenance in regard to the replacement of the light bulbs, some parts of the light fixture remain the same and still require the same level of maintenance (prisms, top cover, bolts).

There are recommended maintenance tasks to ensure that the equipment is in correct operating condition.

Maintenance tasks

Weekly	<ul style="list-style-type: none">• Visual inspection of the light fixture.• Removal of dust from external surfaces of the light fixture.
Monthly	<ul style="list-style-type: none">• Check optical window for cleanliness, mechanical damage or moisture/condensation on the inside of the prism• Check for improper torque on mounting bolts. Re-torque if needed.
Yearly	<ul style="list-style-type: none">• Detailed inspection of the light fixture• Check of the body resistance, check for mechanical damage (for example cracks around the prism windows).• Clean optical windows
Bi-yearly	<ul style="list-style-type: none">• Check for presence of water in mounting support by unscrewing and lifting light fixture from base and check for water ingress and corrosion. Replace gasket between light fixture and base.
After snow removal	<ul style="list-style-type: none">• Check for damaged light fixtures. Any damaged light fixtures should be replaced and brought in and properly investigated and repaired.

A daily function check is referred to in the document:

ICAO, Airport Services Manual Part 9, Airport Maintenance Practice and FAA AC 150/5340-26A, Maintenance of airport visual aids facilities.

Any issues found during maintenance tasks should be corrected accordingly and properly documented.

A proper asset management system such as ADB Safegate's ALIS can help to store/document data and can provide valuable information on local presiding conditions for preventive maintenance planning. This can then be used to minimize the need for reactive maintenance.



ALIS, ADB Safegate's new digital asset tracking, inspection and service solution, helps airports easily register airside assets, electronically schedule and track maintenance, and record maintenance and inspection tasks in compliance with ICAO and FAA standards.

Visit alis.adbsg.com.

5.2 Recommended Maintenance Program for optimal Service Life

Service Life and Inspection intervals

All products have an expected service life. Service life is the lifetime of the product and reaching the end means that it is no longer serviceable and should be replaced.

There are several key external factors that influences the service life of a product.

- Aircraft traffic movements
- Location on the airfield
- Maintenance
- Chemical usage

Air Traffic Movements (ATM)

The expected lifetime of a light fixture will be highly impacted by the traffic volume and the number of aircraft that are mechanically putting stress on the light fixtures. Airports with a higher traffic volume will have a light fixture with a shorter expected lifetime than an airport with a lower traffic volume.

The ATM can be divided into three categories for the recommendation of inspections as well as for the expected lifetime of a light fixture *.

- 0-100k movements/ year
- 100k-200k movements/ year
- >200k movements/ year

Location on the airfield

The expected lifetime of a light fixture is highly dependent on the location where it is installed on an airfield. Three different areas have been defined by color categorization that are exposed to different degree of mechanical impact. These three categories are used as a basis for the recommendation of inspections as well as for the expected lifetime of a light fixture.

- **RED** – Touch Down Area defined as 6m either side of the runway centerline for a distance starting 50m before the TDZ markings and extending to 200m beyond the TDZ markings as seen from the landing direction.
- **RED** – Rapid Exit Taxiway centerline lights from the runway centerline to 50m beyond the edge of the runway.
- **Amber** – All runway areas outside of the red areas. Also includes taxiway intersections for which more than 50% of the aircraft traffic turn more than 45 degrees.
- **Green** – Areas outside Red and Amber areas



NOTICE

It is recommended that there is a reliable means of recording the location history of fittings (similar to ADB Safegate ALIS) to ensure that the maximum duration in critical areas (RED) of the runway are not exceeded.

* Based on ADB SAFEGATE's field experience and investigation made together with an independent consultant and airport.

Preventive maintenance

Preventive maintenance and inspections will help to prolong the service life of a light fixture. By finding issues (e. g., bad gaskets or broken prisms) at an early stage you can mitigate and fix issue before they cause more damage and reduce the cost of the repair. You can also increase the service life of a light fixture by rotating the installation location of light fixtures in critical areas.

Regular inspections and well-defined preventive maintenance planning will help to reduce the overall maintenance cost and reduce downtime from reactive maintenance tasks.

Figure 9: Preventive Maintenance

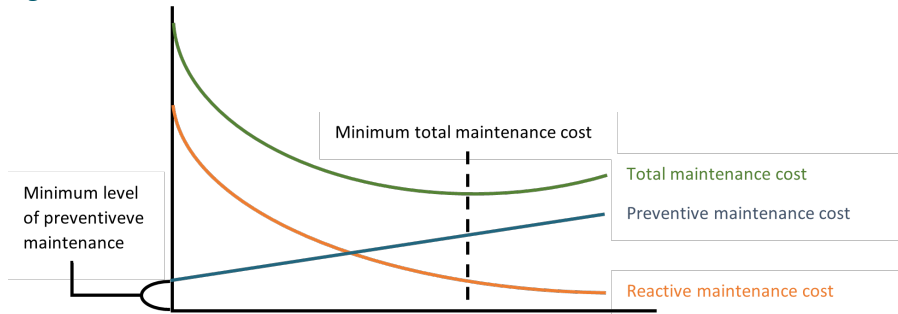

5.2.1 Recommendation

Based on the air traffic volume and location on the airfield, a matrix was created for recommended inspection intervals.

Figure 10: Visual Inspection Interval

Location \ ATM	RED	Amber	Green
0-100k movements	2 Months 1 Year	6 Months 3 Years	1 Year 3 Years
100k-200k movements	2 Months 1 Year	4 Months 2 Years	1 Year 3 Years
Above 200k movements	1 Months 6 Months	2 Months 1 Year	1 Year 3 Years

Inspection interval

Visual inspection: Visually inspect the light fixture and make sure that

- Prism is clean and no cracks are visible
- Gaskets are ok and are not deteriorating
- No moisture or condensation can be seen on the inside of the prism
- Corrosion on top cover, around the prism and bolts.
- Torquing of nuts/bolts are according to specification

Detailed Inspection: Includes visual inspection tasks and additionally the following tasks

- Unbolt the light fixture and lift it from the base for the detailed inspection
- Check for water ingress (watertight installation) and corrosion on light fixture and base (especially around the mating surfaces)
- For deep base installation (L-868) check for water ingress, if more than 6 inches please have it removed.
- Inspect light and base for damage
- Replace gasket between light fixture and base

i NOTICE

We recommend any maintenance work that requires the light fixture to be opened to be done back in the dedicated maintenance area.

- We recommend that inspection intervals are halved for aging units that have reached more than 75 % of their expected lifetime.
- We recommend that AGL in critical areas are rotated.
- To achieve a proper location rotation and individual asset, data needs to be recorded.
- To relax the recommended frequencies of some maintenance tasks i.e. torque management, data is needed for justification.
- Policies have a direct link with the age of the AGL and should also be tracked and recorded.

Below is the recommended service life. With a proper asset management (ALIS or similar) and data capturing strategy, the below guidelines could be extended or shortened as deemed necessary via presiding local conditions.

Expected service life (only critical areas defined)

• RED Zone -, ATM < 100k	Service Life 15 years
• RED Zone -, ATM > 100k < 200K	Service Life 10 years
• RED Zone -, ATM > 200k	Service Life 7 years



Note

Contact to your local sales representative if you have any questions or would require some assistance to go through local conditions and see how we can help establish a well-defined maintenance planning to optimize the expected service life of your investment.

5.3 Workshop Maintenance

The workshop maintenance refers to following:

1. Open a Light Fixture
2. Close a Light Fixture
3. Replace the Power Wire Harness
4. Replace the Light Engine Assembly
5. Replace the Prism
6. Replace the Top Cover Assembly
7. Replace the Bottom Pan Assembly
8. Replace the secondary Cable
9. Reset the Fail-open Converter
10. Check the Light Fixture for Water-tightness

5.3.1 Opening a Light Fixture — disconnecting the Bottom Pan from the Top Cover

Tools to be used:

- Variable-speed/Torque drill driver with T25 bit



NOTICE

Do not use an Impact driver.

- Flat-head screwdriver

1. Place the light fixture upside down.
2. Loosen the Pressure Release Screw.
3. Unscrew the fixation screws.
Make sure you **dispose the old screws** and use new screws.
4. Lift the Bottom Pan without damaging the connecting wires.



CAUTION

Make sure you do not damage the cables when opening the light fixture.

5. Disconnect the wires:
 - a. Pull carefully to disconnect the wires between the converter and the light engine.
 - b. Pull carefully to disconnect the wires between the converter and the heater kit(s), if the heater kit is in place.
6. Remove the gasket between the Top Cover Assembly and the Inner Pan Assembly.
Make sure you **dispose the old gasket** and use a new gasket.

5.3.2 Closing a Light Fixture — connecting the Bottom Pan to the Top Cover



Note

Replacement light engines are provided with the power wire harness installed.

Tools to be used:

- Variable-speed/Torque drill driver with T25 bit
-



NOTICE

Do not use an Impact driver.

- Flat-head screwdriver
1. Clean all the contact surfaces of the light fixture and of the housing carefully.
 2. Press the gasket (located between top cover and inner pan) into the O-ring Groove.
Make sure the gasket placed correctly.
-

Important

The O-ring Gasket must always be changed when the fixture is being disassembled.

3. Connect the wires:
 - a. Press carefully to connect the wires lead in from the light engine on the converter.
 - b. Press carefully to connect the wires lead in from the light engine on the converter, if the heater kit is in place.
 4. Put the Top Cover onto the Bottom Pan.
Make sure the poke-yoke (alignment pin) is in the placed correctly.
-

Important

Do not pinch the wires or the gasket.

5. Put the light fixture on a surface with the top cover facing down.
 6. Torque:
 - a. Use new fixation screws to torque in star pattern at 31 in-lbs (3.5 Nm).
 - b. Retorque the screws in star pattern at 31 in-lbs (3.5 Nm).
 7. Follow the water-tightness test procedure.
-



Note

Refer to the [Checking the Light Fixture for Water-tightness](#) section.

5.3.3 Replacing the Power Wire Harness

Figure 11: Power harness replacement



i NOTICE The arctic kit wire harness is soldered to the light engine. The arctic kit is to be replaced if this harness is damaged.

Tools to be used:

- Variable-speed/Torque drill driver with T20 bit

i NOTICE Do not use an Impact driver.

1. Open the light.

i Note Refer to the [Opening a Light Fixture — disconnecting the Bottom Pan from the Top Cover](#) section.

2. Remove the LED brackets (3 pieces M5 screws per bracket) to access the connector of the LED wire. Make sure you **dispose the old screws** and use new screws.

Figure 12: LED bracket removal

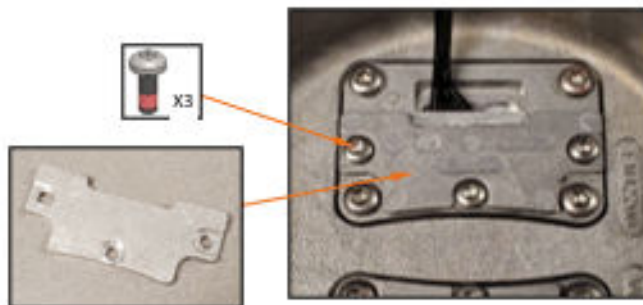

3. Disconnect the old wire harnesses. Make sure you **dispose the old wire harnesses** and use new wire harnesses.
4. Connect the new wire harnesses.

5. Mount the LED bracket with new screws at 26 in-lbs (3 Nm).
 6. Close the light.
-



Note

Refer to the [Closing a Light Fixture — connecting the Bottom Pan to the Top Cover](#) section.

5.3.4 Replacing the Light Engine Assembly

Tools to be used:

- Screwdriver or variable-speed/Torque drill driver with T20 bit



NOTICE

Do not use an Impact driver.

1. Open the light.



Note

Refer to the [Opening a Light Fixture — disconnecting the Bottom Pan from the Top Cover](#) section.

2. Remove the Light engine(s) (4 pieces M4 screws per light engine assembly).
Make sure you **dispose the old screws, light engine(s), and wire harness(es)**, and the new material.
3. Mount the new light engine(s).
4. Use new screws to attach the light engine in star pattern at 31 inch-pound (3.5 Nm).
5. Retorque the screws in star pattern at 31 inch-pound (3.5 Nm)
6. Close the light.



Note

Refer to the [Closing a Light Fixture — connecting the Bottom Pan to the Top Cover](#) section.

5.3.5 Replacing the Prism and its Gasket

Tools to be used:

- Screwdriver or variable-speed/Torque drill driver with T25 bit



NOTICE

Do not use an Impact driver.

1. Open the light.



Note

Refer to the [Opening a Light Fixture — disconnecting the Bottom Pan from the Top Cover](#) section.

2. Remove the Light engine (4 M4 screws per light engine assembly).

Make sure you **dispose the old screws** and use new screws.

Figure 13: Light engine removal

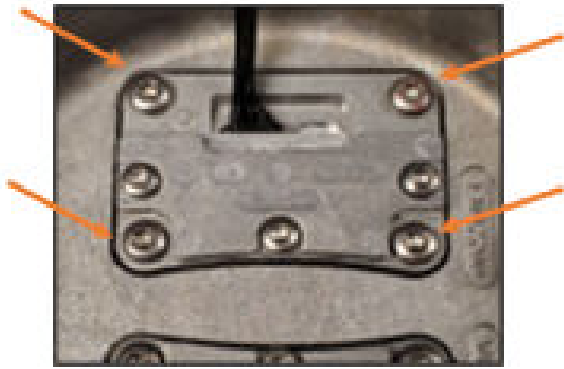

3. Remove the prism the prism gasket by pushing from outside.
Make sure you **dispose the old prisms and gaskets** and the new material.
4. Mount the new prism gasket into the top cover.

Important

Make sure the wider slant is oriented towards the center of the fixture.

5. Mount the new prism into the correctly placed top cover.

Important

Make sure the prism is fully flush on the outside and the prism surfaces are clean (without grease or dirt).

6. Mount the light engine.
7. Use new screws to attach the light engine in star pattern at 31 inch-pound (3.5 Nm).

Figure 14: Sequence

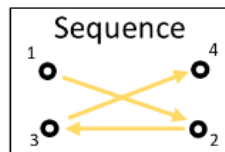

8. Retorque the screws in star pattern at 31 inch-pound (3.5 Nm).
9. Close the light.



Note

Refer to the [Closing a Light Fixture — connecting the Bottom Pan to the Top Cover](#) section.

5.3.6 Replacing the Top Cover Assembly

Tools to be used:

- Screwdriver T25 bit
- Flat-head screwdriver

1. Open the light.



Note

Refer to the [Opening a Light Fixture — disconnecting the Bottom Pan from the Top Cover](#) section.

- Remove the Light Engine(s) (4 pieces M4 screws per light engine assembly).

Figure 15: Light engine removal

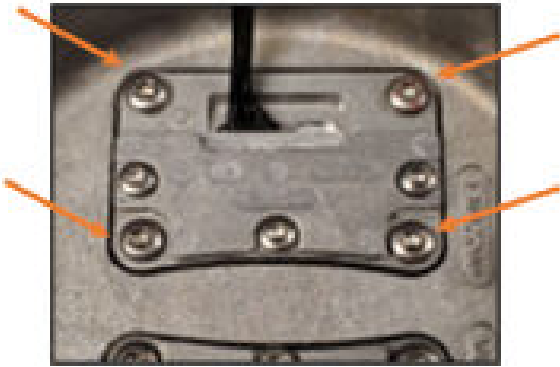

Make sure to **dispose the old screws and the old top cover** and use the new material.

- Replace the old top cover with new top cover assembly.
- Mount the light engine(s) into the new top cover assembly.
- Use new screws to attach the light engine in star pattern at 31 inch-pound (3.5 Nm).



- Retorque the screws in star pattern at 31 inch-pound (3.5 Nm).
- Close the light.



Note

Refer to the [Closing a Light Fixture — connecting the Bottom Pan to the Top Cover](#) section.

5.3.7 Replacing the Bottom Cover Assembly

Tools to be used:

- Screwdriver T25 bit
- Flat-head screwdriver

- Open the light.



Note

Refer to the [Opening a Light Fixture — disconnecting the Bottom Pan from the Top Cover](#) section.

Make sure you **dispose the old bottom cover assembly** and use the new assembly.

- Close the light.



Note

Refer to the [Closing a Light Fixture — connecting the Bottom Pan to the Top Cover](#) section.

5.3.8 Replacing the secondary Cable — SJO cord set

Figure 16: Secondary cable replacement



Tools to be used:

- Screwdriver T25 bit
- Flat-head screwdriver
- Small flat head screwdriver

1. Open the light.



Note

Refer to the [Opening a Light Fixture — disconnecting the Bottom Pan from the Top Cover](#) section.

2. Disconnect the cable:

- a. Disconnect the secondary cable from the converter by placing a small flat-head screwdriver into the opening located at the other side of the secondary wire, and
- b. Release the cable by prying the screwdriver on the cable release opening.

3. Unscrew the Strain-relief Bolt and its plate.

Make sure you **dispose the old Strain-relief Bolt and its plate** and use the new material.

4. Unscrew the cable clamp.

Make sure you dispose **the old bolt, washer and lock washer** and use the new material.

5. Remove the secondary cable

Make sure you dispose **the old secondary cable** and use the new secondary cable.

6. Replacement:

- a. Pull the secondary wires through the Strain-relief Plate and
- b. Mount the new secondary cable by torquing the new strain relief bolt at XX in-lbs XX Nm.

7. Tighten the new cable clamp bolt with the washer and lock washer at XX in-lbs XX Nm.

8. Locking:
 - a. Lock the secondary cables into the converter by opening the cable holes prying a thin screw driver on the cable release opening and mounting the wires in place
 - b. Lock the cables by releasing screw driver from the opening.
9. Close the light.



Note

Refer to the [Closing a Light Fixture — connecting the Bottom Pan to the Top Cover](#) section.

5.3.9 Replacing the secondary Cable — Style-6 cord set

Figure 17: Secondary cable replacement



Tools to be used:

- Screwdriver T25 bit
- Flat-head screwdriver
- Small flat head screwdriver

1. Open the light.



Note

Refer to the [Opening a Light Fixture — disconnecting the Bottom Pan from the Top Cover](#) section.

2. Disconnect the cable:
 - a. Disconnect the secondary cable from the converter by placing a small flat-head screwdriver into the opening located at the other side of the secondary wire, and
 - b. Release the cable by prying the screwdriver on the cable release opening.
3. Unscrew the Strain-relief Bolt and its plate.
Make sure you **dispose the old Strain-relief Bolt and its plate** and use the new material.
4. Unscrew the Strain Relief Bolt, the plate and the cable gland gaskets.
Make sure you dispose **the old Strain Relief Bolt, the plate and the cable gland gaskets** and use the new material.
5. Remove the secondary cable
Make sure you dispose **the old secondary cable** and use the new secondary cable.

6. Mount the new cable gland gaskets.
 7. Replacement:
 - a. Pull the secondary wires through the Strain-relief Plate and the cable gland gaskets and
 - b. Mount the new secondary cable by torquing the new Strain-relief Bolt at XX in-lbs (XX Nm).
 8. Locking:
 - a. Lock the secondary cables leading to the converter by opening the cable holes prying a thin screwdriver on the cable release opening and mounting the wires in place and
 - b. Lock the cables by releasing screwdriver from the opening.
 9. Close the light.
-



Note

Refer to the [Closing a Light Fixture — connecting the Bottom Pan to the Top Cover](#) section.

5.3.10 Resetting the Fail-open Converter

Parts

- Fuse resistor spare part kit: 20210209 (20 pcs)

Info

- Converter with 1 connector have 2 fuse resistors
- Converter with 2 connectors have 4 fuse resistors

Reset / replace the fuse resistors

1. Disconnect and disassemble the light fixture.
 2. Locate the fuse resistors.
-



Note

Refer to [Figure 18](#) and [Figure 19](#) figures.

Refer to Figure.

Figure 18: Converter, 1-connector

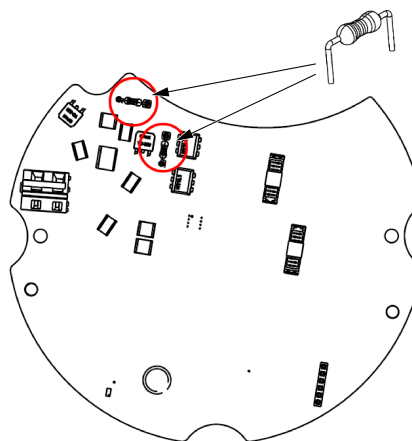
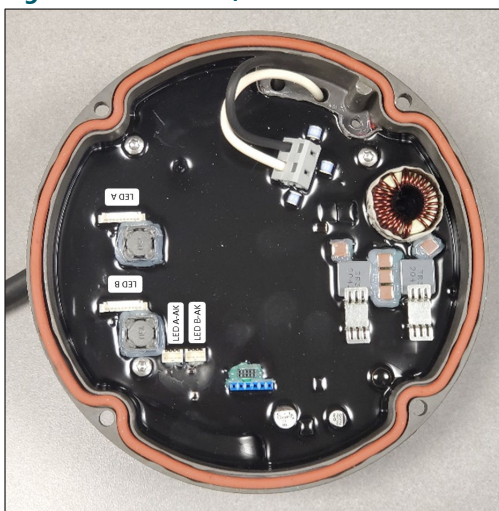
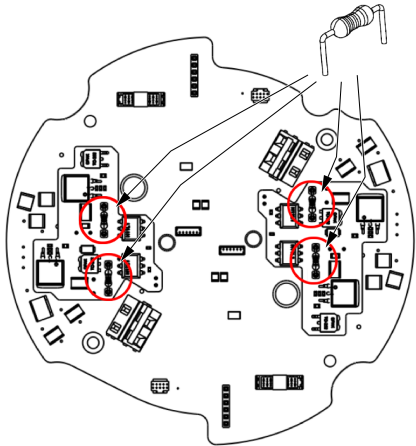

Figure 19: Converter, 2-connector



Figures 1 and 2

3. Remove the fuse resistors by pulling away from the converter.
 - a. For converters with 1 connector, always replace both fuse resistors at the same time.
 - b. For converters with 2 connectors, always replace both fuse resistors related to the A/B channel that needs to be reset.

Make sure you replace all 4 fuse resistors, if both A and B channel needs a reset.
4. Dispose the old fuse resistor.
5. Place the legs of the new fuse resistors in the sockets.
6. Assemble the light fixture and perform a functional test.

5.3.11 Checking the Light Fixture for Water-tightness

Tools to be used:

- Flat head screwdriver
- For water tight testing, pressure test fitting tool to be used : 44A6104/A

Execute the following procedure to test for leaks:

1. Remove the Pressure-relief Screw.
Refer to the image below.

Figure 20: Pressure-relief screw removal

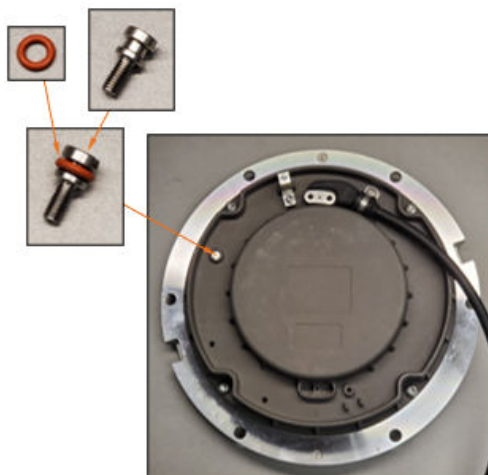

2. Screw the pressure test fitting to the Pressure-relief Port.



NOTICE

The Pressure-relief Port is the opening you created when the pressure relief screw was removed.

3. Screw the fitting hand-tight.

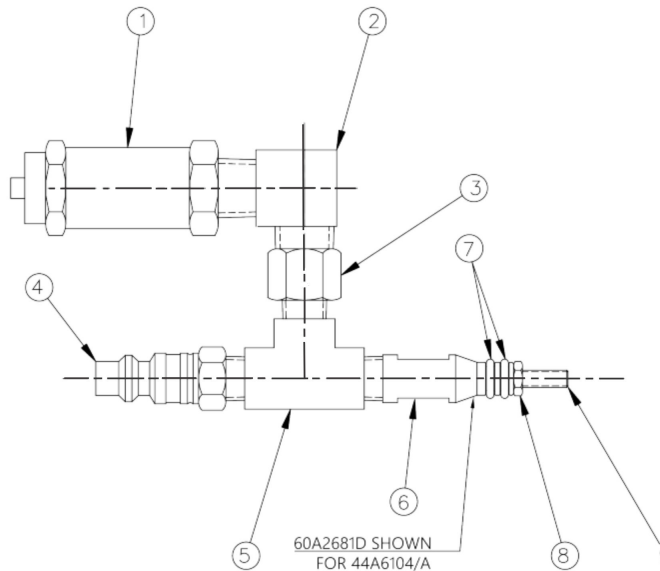

Call-out	Description
1	Pop — safety valve
2	90 deg., elbow, female X male, brass, 1/4"
3	Adapter, female — male, 1/4 x 1/8, brass
4	Sleeve — lock hose plug, 1/4" coupler
5	Tee, brass, 1/8
6	Pressure test fitting, body
7	O-ring, silicone, size 008, 1/16 W X 3/16
8	M4 Hex Jam nut, 18-8 SS
9	Pressure test fitting stud

4. Pressurize to 20 psi (130 kPa).
5. Submerge the pressure test fitting in a water tank.
6. Wait 3 minutes and check if air leaks out of the light.

If air leaks out of the light fixture (between the Bottom Cover and the top plate or between the prism and top plate or watertightness valve and top plate), the light fixture is not watertight and must be repaired. Release the air from the light. Disassemble the light fixture and re-check the mating surfaces and gaskets. Assemble the light fixture and perform the water-tightness test again.

7. Depressurize and reinstall the pressure release screw (1) at 26 in-lbs (3 Nm), if the fixture is watertight.



DANGER

Never exceed a pressure of 22 psi (150 kPa) inside the light fixture. A higher pressure may cause injuries and damage the light.

6.0 Ordering Codes

Ordering Code Notes

EQ light fixtures are only available as a one connector option.

¹ Required for FAA when using AIP funds.

² If a 2-cord set fixture is required meeting BAP, digit 13, "Power and Monitoring", must be M.

³ 2 x Style 1 or 6 options are available under "Cable and Connector".

⁴ All Style 1 corded fixtures will include a ground lug. All Style 6 and 3-pole corded fixtures will be provided with grounding screw(s).

⁵ Only available in Digit 13 options S and M and Bi-directional configuration.

⁶ Color used with L-852D(L) for medium intensity runway edge and threshold applications.

⁷ L-852J&K(L) unidirectional applications only.

⁸ Not ETL submitted.

6.2 Ordering Code LED Taxiway Centerline (ICAO)

Ordering Code

RS□□□□□□□□□□

Application

TC = Taxiway Centerline narrow¹
TK = Taxiway Centerline curved²
TR = Enhanced Taxiway Centerline
for Rapid Exit³
TW = Taxiway centerline wide^{4,5}

Standards

3 = ICAO⁶

Market-specific

0 = None

Dimensions

1 = 8 inch (203 mm) diameter
2 = 12 inch (305 mm) diameter, 11.25 inch
BC (285 mm)

Prism

S = Standard prism
R = Reinforced prism

Beam Orientation

1 = Unidirectional
2 = Bidirectional

Toe-in

N = None⁸
C = Curved^{7,8}

Color – Side 1 (Left)

G = G-Green (ICAO and MOS)
F = F-Green (ICAO, STD)
Y = Yellow
B = Blue
N = None⁹

Color – Side 2 (Right)

G = G-Green (ICAO and MOS)
F = F-Green (ICAO, STD)
Y = Yellow
B = Blue
N = None

Power and Monitoring

S = 2.8 A – 6.6 A, non-monitored — power only¹⁰
M = 2.8 A – 6.6 A, Fail-open monitoring¹⁰
R = 2.8 A – 6.6 A, EQ integrated LINC 360

Cable and connector

1 = 1 x Style 6 2-pole plug, 2 individual wires¹¹
2 = 1 x Style 1 2-pole plug^{11,12}
3 = 2 x Style 6 2-pole plug, 2 individual wires^{11,13}
4 = 2 x Style 1 2-pole plug^{11,12,13}
5 = 1 x flat 3-pole plug, 3 individual wires¹¹
6 = 2 x flat 3-pole plug, 3 individual wires^{11,13}

Options

0 = None
1 = Arctic kit

Version

1 = Version 1

Ordering Code Notes

Light fixtures with internal remote allows for control and monitoring of the light fixture. Light fixtures with internal remotes are only available as 1-connector option.

¹ Straight sections, Narrow Beam, < 350 m RVR.

² Lead-on/exit, Curved Beam, < 350 m RVR.

³ Taxiway centerline, Wide Beam, < 350 m RVR.

⁴ Taxiway centerline, straight sections, Wide Beam, < 350 m RVR.

⁵ TW application includes Intermediate Holding Position light which is Yellow/Blank with wide beam distribution.

⁶ Includes standards NATO, EASA, STAC, TP 312 and MOS 139.

⁷ TK application only.

⁸ To assure the correct toe-in direction, per color, place the required color option in Side 1 (Left) and/or 2 (Right). Left and right side determined by standing over fixture while looking towards the taxiway edge in the direction of the curve.

⁹ TK CVR application only.

¹⁰ 2-cord set option available.

¹¹ All Style 1 corded fixtures will include a ground lug. All Style 6 and 3-pole corded fixtures will be provided with grounding screw(s).

¹² Jacketed SO 2 core cable.

¹³ Not valid option for unidirectional.

Ordering Code Notes

¹L and R designations are always in relationship to Side 1 only.

²3N and 3W applications.

³3C bidirectional application.

⁴3C unidirectional application.

⁵2-cord-set option available.

⁶All Style 1 corded fixtures will include a ground lug. All Style 6 and 3-pole corded fixtures will be provided with grounding screw(s).

⁷Only available in Digit 13 options S and M and bi-directional configuration.

⁸SO cord set option is not compatible with shallow bases.

6.4 Ordering Code LED Stopbar (ICAO)

Ordering Code	RS										
Application SB = ICAO Stop Bar wide beam											
Standards 3 = ICAO ¹											
Market-specific 0 = None											
Dimensions 1 = 8 inch (203 mm) diameter 2 = 12 inch (305 mm) diameter, 11.25 inch BC (285 mm)											
Prism S = Standard prism R = Reinforced prism											
Beam Orientation 1 = Unidirectional 2 = Bidirectional											
Toe-in N = None C = Curved											
Color – Side 1 (Left) R = Red N = None ²											
Color – Side 2 (Right) R = Red N = None											
Power and Monitoring S = 2.8 A – 6.6 A, non-monitored — power only ³ M = 2.8 A – 6.6 A, Fail-open monitoring ³ R = 2.8 A - 6.6 A, EQ integrated LINC 360											
Cable and connector 1 = 1 x Style 6 2-pole plug, 2 individual wires ⁴ 2 = 1 x Style 1 2-pole plug, jacketed SO 2-core cable ⁴ 3 = 2 x Style 6 2-pole plug, 2 individual wires ^{4,5,6} 4 = 2 x Style 1 2-pole plug, jacketed SO 2-core cable ^{4,5,6} 5 = 1 x flat 3-pole plug, 3 individual wires ⁴ 6 = 2 x flat 3-pole plug, 3 individual wires ^{4,6}											
Options 0 = None 1 = Arctic kit											
Version 1 = Version 1											

Ordering Code Notes

Light fixtures with internal remote allows for control and monitoring of the light fixture. Light fixtures with internal remotes are only available as 1-connector option.

¹ Includes standards NATO, EASA, STAC, and MOS 139.

² Curved application only.

³ 2-Cord set option available for bidirectional fixtures (not EQ).

⁴ All Style 1 corded fixtures will include a ground lug. All Style 6 and 3-pole corded fixtures will be provided with grounding screw(s).

⁵ Only available in Digit 13 options S and M and bi-directional configuration.

⁶ Not valid option for unidirectional

6.5 Ordering Code LED L-852S(L) LED Stop Bar (FAA)

Ordering Code	RS												
Application SB = FAA Stop bar													
Standard 2 = FAA ¹													
Market Specific 0 = None 1 = Buy American Preference (BAP) ²													
Dimensions 1 = 8 inch (203 mm) diameter 2 = 12 inch (305 mm) diameter, 11.25 inch BC (285 mm) 3 = 8 inch (203 mm) diameter, 4-bolt													
Prism S = Standard prism R = Reinforced prism ³													
Beam Orientation 1 = Unidirectional													
Toe-in N = None													
Color – Side 1 R = Red													
Color – Side 2 N = Not applicable													
Power and Monitoring S = 2.8 A - 6.6 A, non-monitored — power only M = 2.8 A - 6.6 A, Fail-open monitoring R = 2.8A - 6.6 A, EQ integrated LINC 360													
Cable and connector ² 1 = 1 x Style 6 2-pole plug, 2 individual wires ⁴ 2 = 1 x Style 1 2-pole plug, jacketed SO 2-core cable ⁴													
Options 0 = None 1 = Arctic Kit													
Version 1 = Version 1													

Ordering Code Notes

¹ Includes TP-312.

² Required for FAA when using AIP funds.

³ Not ETL submitted

⁴ All Style 1 corded fixtures will include a ground lug. All Style 6 and 3-pole corded fixtures will be provided with grounding screw(s).

7.0 Spare Parts

Spare parts are available for inset light fixtures with and without the control and monitoring functionality. For more information, see <http://www.adbsafegate.com/> and the spare part lists, or contact ADB SAFEGATE for assistance.

7.1 Versions and Exploded View

Versions, 8-inch and 12-inch Insets

Figure 21: Taxiway Insets, cord set options

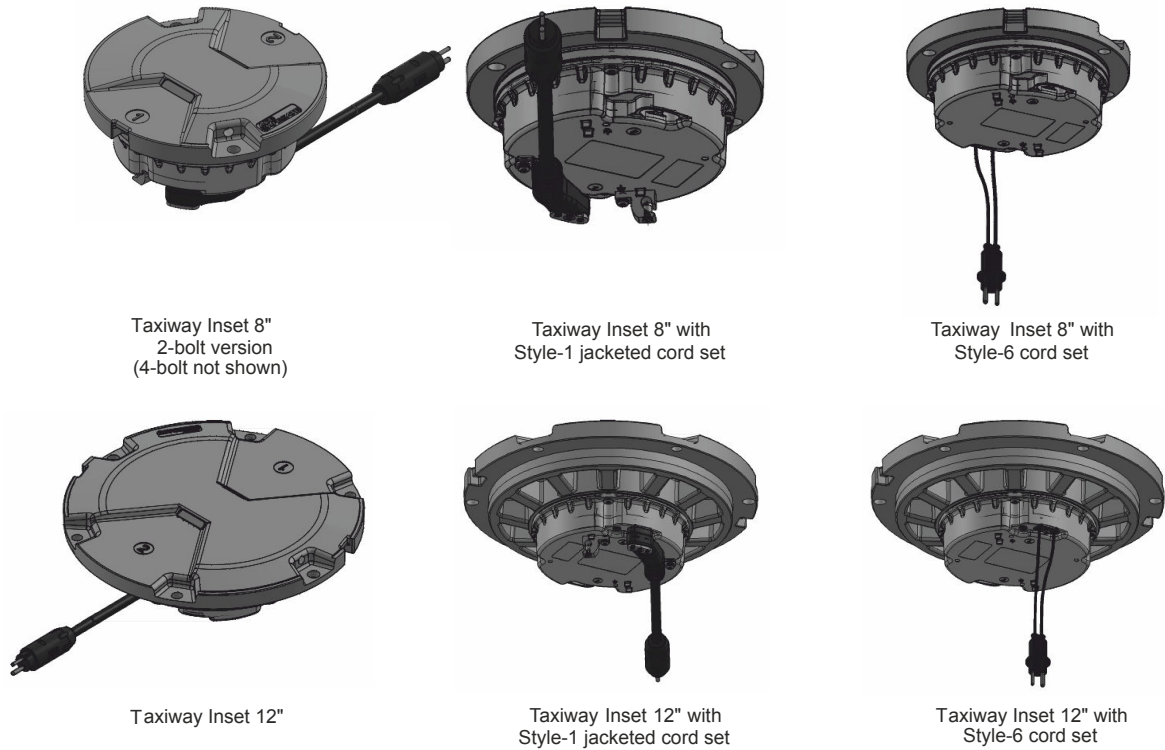

Partial Exploded View — Spare part Assemblies

Figure 22: 8-inch (left) and 12 inch(right)

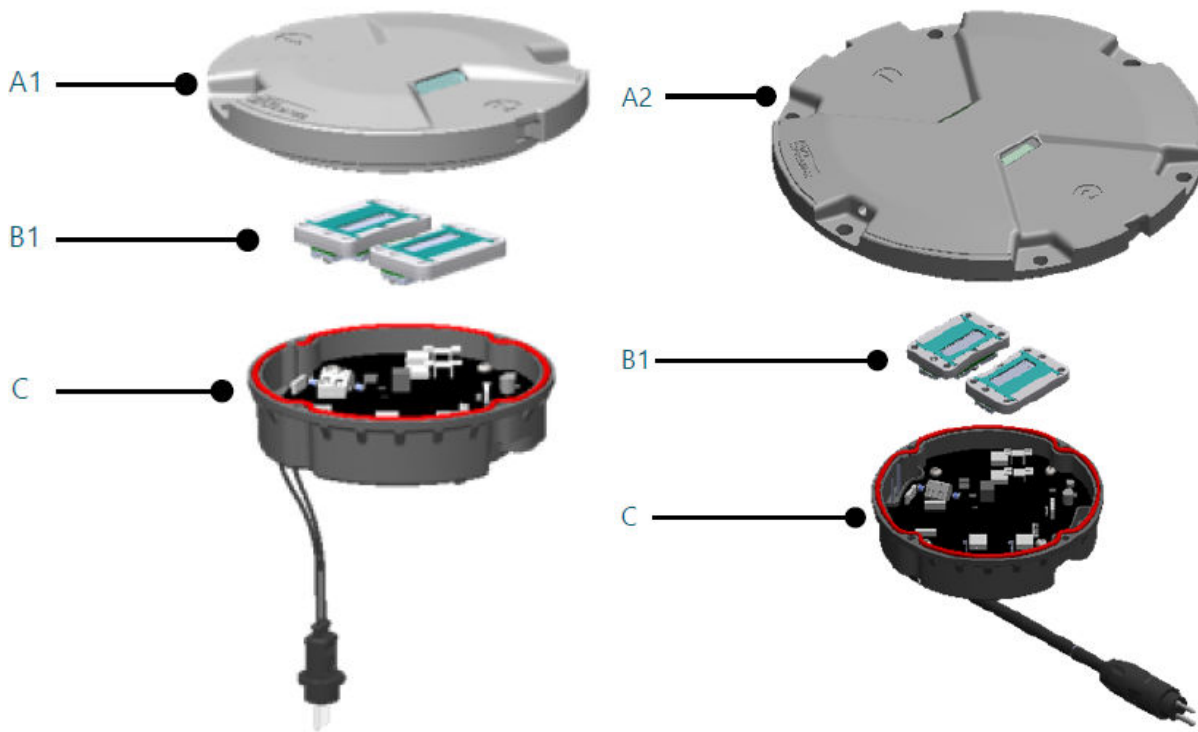

Call-out	Description	Assembly number prefix
A1	Top Cover Assembly, 8-inch	SP.AS00135-XXX
A2	Top Cover Assembly, 12-inch	SP.AS00136-XXX
B1	Light Engine Assembly, 8-inch and 12-inch, no Arctic Kit	SP.AS00089-XXX
B2(not shown)	Light Engine Assembly, 8-inch and 12-inch, with Arctic Kit	SP.AS00137-XXX
C	Bottom Pan Assembly, 8-inch and 12-inch	SP.AS00021-XXX

i Note

Full assembly numbers are listed in the spare part tables per application, starting from page 60 in the user manual.

7.2 Spare Part Illustrations

Figure 23: Top Cover Assemblies, 8-inch

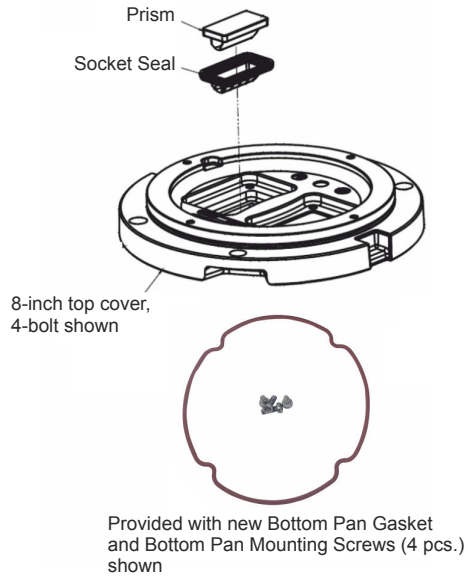

Figure 24: Top Cover Assemblies, 12-inch

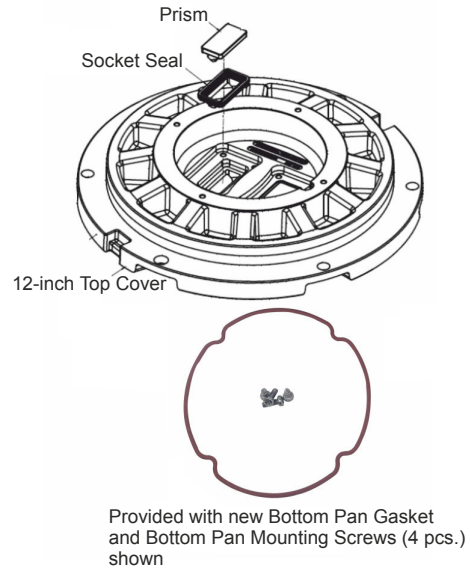
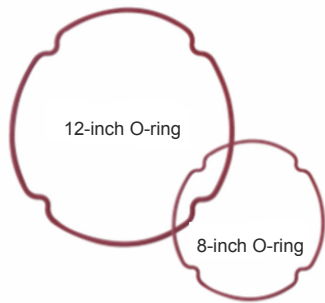
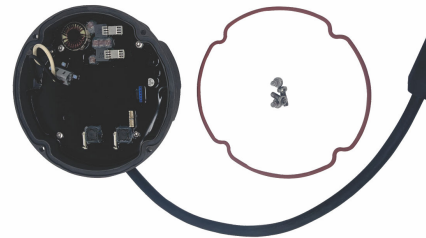

Figure 25: Bottom Pan gasket, 8-inch and 12-inch



Bottom Pan gasket (package of 10 pcs.)
available options : 8 - inch & 12 - inch
for Taxiway applications only 8 - inch
gaskets are used

Figure 26: Bottom Pan assembly, 8-inch



8 - inch Taxiway Bottom Pan assembly
compatible with both 8 - inch and
12 - inch top covers

Figure 27: LED light engines wire harness, package of 10



Figure 28: Light Engine assembly for 8-inch and 12-inch



Figure 29: Prism spares



Taxiway replacement prism (package of 2 pcs.),
available options:
Standard
Reinforced (Sapphire coated)

Figure 30: Ground lugs, package of 5



Figure 31: Style-1 Cord Set Cable Clamp, package of 5



Figure 32: Mounting screws, package of 100



Figure 33: Pressure release screws, package of 5



Note

Pressure release screw O-ring is to be replaced with new O-ring prior to re-installation of the pressure relief screw.

7.3 Spare Parts — Taxiway Centerline Light FAA



NOTICE

- Each Top Cover Assembly includes a Bottom Cover Gasket and a Bottom Cover Screws.
- BAP stands for "Buy American Preference".

A1 - Top cover assemblies, 8-inch	Quantity per		spare part code
	fitting	spare part	
unidirectional straight, standard prism	1	1	SPAS00135-S1S
unidirectional straight, reinforced prism	1	1	SPAS00135-S1R
unidirectional side 1 curved, standard prism	1	1	SPAS00135-C1S
unidirectional side 1 curved, reinforced prism	1	1	SPAS00135-C1R
unidirectional side 2 curved, standard prism	1	1	SPAS00135-C3S
unidirectional side 2 curved, reinforced prism	1	1	SPAS00135-C3R
bidirectional straight, standard prism	1	1	SPAS00135-S5S
bidirectional straight, reinforced prism	1	1	SPAS00135-S5R
bidirectional curved, standard prism	1	1	SPAS00135-C5S
bidirectional curved, reinforced prism	1	1	SPAS00135-C5R
4-bolt unidirectional straight, standard prism	1	1	SPAS00135-S2S
4-bolt unidirectional straight, reinforced prism	1	1	SPAS00135-S2R
4-bolt unidirectional side 1 curved, standard prism	1	1	SPAS00135-C2S
4-bolt unidirectional side 1 curved, reinforced prism	1	1	SPAS00135-C2R
4-bolt unidirectional side 2 curved, standard prism	1	1	SPAS00135-C4S
4-bolt unidirectional side 2 curved, reinforced prism	1	1	SPAS00135-C4R
4-bolt bidirectional straight, standard prism	1	1	SPAS00135-S6S
4-bolt bidirectional straight, reinforced prism	1	1	SPAS00135-S6R
4-bolt bidirectional curved, standard prism	1	1	SPAS00135-C6S
4-bolt bidirectional curved, reinforced prism	1	1	SPAS00135-C6R

A2 - Top cover assemblies, 12-inch	Quantity per		spare part code
	fitting	spare part	
unidirectional straight, standard prism	1	1	SPAS00136-S1S
unidirectional straight, reinforced prism	1	1	SPAS00136-S1R
unidirectional side 1 curved, standard prism	1	1	SPAS00136-C1S
unidirectional side 1 curved, reinforced prism	1	1	SPAS00136-C1R
unidirectional side 2 curved, standard prism	1	1	SPAS00136-C2S
unidirectional side 2 curved, reinforced prism	1	1	SPAS00136-C2R
bidirectional, straight, standard prism	1	1	SPAS00136-SBS

A2 - Top cover assemblies, 12-inch	Quantity per		spare part code
	fitting	spare part	
bidirectional, straight, reinforced prism	1	1	SPAS00136-SBR
bidirectional curved, standard prism	1	1	SPAS00136-CBS
bidirectional curved, reinforced prism	1	1	SPAS00136-CBR

B1 & B2 - Light engine assembly, 8" and 12" (without heater)	Quantity per		spare part code
	fitting	spare part	
F-green for L-852A/B/J(L)	1 or 2	1	SPAS00089-OFF
yellow for L-852A/B/J(L)	1 or 2	1	SPAS00089-OYY
F-green for L-852D(L)	1 or 2	1	SPAS00089-DFF
white for L-852D(L)	1 or 2	1	SPAS00089-DWW
yellow for L-852D(L)	1 or 2	1	SPAS00089-DYY
F-green curved for L-852K(L)	1 or 2	1	SPAS00089-CFN
yellow curved for L-852K(L)	1 or 2	1	SPAS00089-CYN
F-green narrow for L-852C(L)	1 or 2	1	SPAS00089-NFN
yellow narrow for L-852C(L)	1 or 2	1	SPAS00089-NYN

B1 & B2 - Light engine assembly, 8" and 12" (with heater)	Quantity per		spare part code
	fitting	spare part	
F-green for L-852A/B/J(L), non-monitored (S-BAP) or EQ (R)	1 or 2	1	SPAS00137-OFF-E
yellow for L-852A/B/J(L), non-monitored (S-BAP) or EQ (R)	1 or 2	1	SPAS00137-OYY-E
F-green for L-852D(L), non-monitored (S-BAP) or EQ (R)	1 or 2	1	SPAS00137-DFF-E
white for L-852D(L), non-monitored (S-BAP) or EQ (R)	1 or 2	1	SPAS00137-DWW-E
yellow for L-852D(L), non-monitored (S-BAP) or EQ (R)	1 or 2	1	SPAS00137-DYY-E
F-green curved for L-852K(L), non-monitored (S-BAP) or EQ (R)	1 or 2	1	SPAS00137-CFN-E
yellow curved for L-852K(L), non-monitored (S-BAP) or EQ (R)	1 or 2	1	SPAS00137-CYN-E
F-green narrow for L-852C(L), non-monitored (S-BAP) or EQ (R)	1 or 2	1	SPAS00137-NFN-E
yellow narrow for L-852C(L), non-monitored (S-BAP) or EQ (R)	1 or 2	1	SPAS00137-NYN-E
F-green for L-852A/B/J(L), non-monitored (S-non-BAP) or monitored (M)	1 or 2	1	SPAS00137-OFF-F
yellow for L-852A/B/J(L), non-monitored (S-non-BAP) or monitored (M)	1 or 2	1	SPAS00137-OYY-F
F-green for L-852D(L), non-monitored (S-non-BAP) or monitored (M)	1 or 2	1	SPAS00137-DFF-F
white for L-852D(L), non-monitored (S-non-BAP) or monitored (M)	1 or 2	1	SPAS00137-DWW-F
yellow for L-852D(L), non-monitored (S-non-BAP) or monitored (M)	1 or 2	1	SPAS00137-DYY-F
F-green curved for L-852K(L), non-monitored (S-non-BAP) or monitored (M)	1 or 2	1	SPAS00137-CFN-F

B1 & B2 - Light engine assembly, 8" and 12" (with heater)	Quantity per		spare part code
	fitting	spare part	
yellow curved for L-852K(L), non-monitored (S-non-BAP) or monitored (M)	1 or 2	1	SPAS00137-CYN-F
F-green narrow for L-852C(L), non-monitored (S-non-BAP) or monitored (M)	1 or 2	1	SPAS00137-NFN-F
yellow narrow for L-852C(L), non-monitored (S-non-BAP) or monitored (M)	1 or 2	1	SPAS00137-NYN-F

C - Bottom pan assembly, 8" and 12"	Quantity per		spare part code
	fitting	spare part	
non-monitored converter, style 6 cord set	1	1	SPAS00021-L13
non-monitored converter, style 1 SJO jacketed cord set	1	1	SPAS00021-L1J
non-monitored converter, 2-con style 6 cord sets	1	1	SPAS00021-L23
non-monitored converter, 2-con style 1 SJO jacketed cord sets	1	1	SPAS00021-L2J
monitored converter, style 6 cord set	1	1	SPAS00021-M13
monitored converter, style 1 SJO jacketed cord set	1	1	SPAS00021-M1J
monitored converter, 2-con style 6 cord sets	1	1	SPAS00021-M23
monitored converter, 2-con style 1 SJO jacketed cord sets	1	1	SPAS00021-M2J
EQ converter, style 6 cord set	1	1	SPAS00021-R13
EQ converter, style 1 SJO jacketed cord set	1	1	SPAS00021-R1J
Buy American Preference non-monitored converter, style 6 cord set	1	1	SPAS00021-S13
Buy American Preference non-monitored converter, style 1 SJO jacketed cord set	1	1	SPAS00021-S1J

Cord set	Quantity per		spare part code
	fitting	spare part	
Cord set, L-823 style 1, 8" bottom pan	1 or 2	5	SP.73A0193/1
Cord set, L-823 style 1, 12" bottom pan	1 or 2	5	SP.73A0194/1
Cord set, L-823 style 6, 8" & 12" bottom pan	1 or 2	5	SPSGE96253351
Cable retaining clamp, for use with style 1 cord set	1 or 2	5	SPMB00003-013-01
Ground lug kit	1	5	SP.72A0401

Prism spares	Quantity per		spare part code
	fitting	spare part	
Prism kit, taxiway, standard	1 or 2	2	SP4072.40.412
Prism kit, taxiway, reinforced	1 or 2	2	SP4072.42.090

Screws & gaskets	Quantity per		spare part code
	fitting	spare part	
Pressure release screw with o-ring	1	5	SPMF00090-000-01
Gasket, 8" bottom pan	1	10	SPMS00005-000-01
Screws, 8" bottom pan	-	100	SPMFPM5PT-714-01
Screws, light engine assembly mounting	-	100	SPMFPM4PT-710-01

Wire Harness	Quantity per		spare part code
	fitting	spare part	
Wire harness, power supply to light engine	1 or 2	10	SPEW00070-150-01
Wire harness, power supply to heater	1 or 2	10	SPEW00069-150-01

Fuse	Quantity per		spare part code
	fitting	spare part	
Fuse resistors (only for fixtures with monitoring (M))	1 or 2	20	6132.00.250



Note

All screws for fastening are included.

Component availability or design may be subject to change due to unforeseen circumstances. This document is subject to change or new information from ADB SAFEGATE, as and when available or if required, with reservation for error or price changes.

For more information or assistance with ordering spare parts, contact ADB SAFEGATE, see www.adbsafegate.com.

7.4 Spare Parts — Taxiway Centerline Light ICAO



NOTICE

- Each Top Cover Assembly includes a Bottom Cover Gasket and a Bottom Cover Screws.
- BAP stands for "Buy American Preference"

A1 - Top Cover Assemblies , 8-inch	Quantity per		spare part code
	fitting	spare part	
unidirectional straight, standard prism	1	1	SPAS00135-S1S
unidirectional straight, reinforced prism	1	1	SPAS00135-S1R
unidirectional side 1 curved, standard prism	1	1	SPAS00135-C1S
unidirectional side 1 curved, reinforced prism	1	1	SPAS00135-C1R
unidirectional side 2 curved, standard prism	1	1	SPAS00135-C3S
unidirectional side 2 curved, reinforced prism	1	1	SPAS00135-C3R
bidirectional straight, standard prism	1	1	SPAS00135-S5S
bidirectional straight, reinforced prism	1	1	SPAS00135-S5R
bidirectional curved, standard prism	1	1	SPAS00135-C5S
bidirectional curved, reinforced prism	1	1	SPAS00135-C5R

A2 -Top Cover Assemblies , 12-inch	Quantity per		spare part code
	fitting	spare part	
unidirectional straight, standard prism	1	1	SPAS00136-S1S
unidirectional straight, reinforced prism	1	1	SPAS00136-S1R
unidirectional side 1 curved, standard prism	1	1	SPAS00136-C1S
unidirectional side 1 curved, reinforced prism	1	1	SPAS00136-C1R
unidirectional side 2 curved, standard prism	1	1	SPAS00136-C2S
unidirectional side 2 curved, reinforced prism	1	1	SPAS00136-C2R
bidirectional, straight, standard prism	1	1	SPAS00136-SBS
bidirectional, straight, reinforced prism	1	1	SPAS00136-SBR
bidirectional curved, standard prism	1	1	SPAS00136-CBS
bidirectional curved, reinforced prism	1	1	SPAS00136-CBR

B1 - Light Engine Assembly, 8-inch and 12-inch without Arctic Kit (without heater)	Quantity per		spare part code
	fitting	spare part	
F-green wide	1 or 2	1	SPAS00089-WFN-TW
F-green enhanced taxiway centreline for rapid exit	1 or 2	1	SPAS00089-WFF-TR
yellow wide	1 or 2	1	SPAS00089-WYN-TW
yellow enhanced taxiway centreline for rapid exit	1 or 2	1	SPAS00089-WYY-TR
F-green curved	1 or 2	1	SPAS00089-CFN

B1 - Light Engine Assembly, 8-inch and 12-inch without Arctic Kit (without heater)	Quantity per		spare part code
	fitting	spare part	
yellow curved	1 or 2	1	SPAS00089-CYN
F-green narrow	1 or 2	1	SPAS00089-NFN
yellow narrow	1 or 2	1	SPAS00089-NYN

B2 - Light Engine Assembly, 8-inch and 12-inch with Arctic Kit (heater)	Quantity per		spare part code
	fitting	spare part	
F-green wide, EQ (R)	1 or 2	1	SPAS00137-WFN-TWE
F-green enhanced taxiway centreline for rapid exit, EQ (R)	1 or 2	1	SPAS00137-WFF-TRE
yellow wide, EQ (R)	1 or 2	1	SPAS00137-WYN-TWE
yellow enhanced taxiway centreline for rapid exit, EQ (R)	1 or 2	1	SPAS00137-WYY-TRE
F-green curved, EQ (R)	1 or 2	1	SPAS00137-CFN-E
yellow curved, EQ (R)	1 or 2	1	SPAS00137-CYN-E
F-green narrow, EQ (R)	1 or 2	1	SPAS00137-NFN-E
yellow narrow, EQ (R)	1 or 2	1	SPAS00137-NYN-E
F-green wide, non monitored (S) or monitored (M)	1 or 2	1	SPAS00137-WFN-TWF
F-green enhanced taxiway centreline for rapid exit, non monitored (S) or monitored (M)	1 or 2	1	SPAS00137-WFF-TRF
yellow wide, non monitored (S) or monitored (M)	1 or 2	1	SPAS00137-WYN-TWF
yellow enhanced taxiway centreline for rapid exit, non monitored (S) or monitored (M)	1 or 2	1	SPAS00137-WYY-TRF
F-green curved, non monitored (S) or monitored (M)	1 or 2	1	SPAS00137-CFN-F
yellow curved, non monitored (S) or monitored (M)	1 or 2	1	SPAS00137-CYN-F
F-green narrow, non monitored (S) or monitored (M)	1 or 2	1	SPAS00137-NFN-F
yellow narrow, non monitored (S) or monitored (M)	1 or 2	1	SPAS00137-NYN-F

C - Bottom Cover Assemblies	Quantity per		spare part code
	fitting	spare part	
non-monitored converter, style 6 cord set	1	1	SPAS00021-L13
non-monitored converter, 3-pole cord set	1	1	SPAS00021-L1F
non-monitored converter, style 1 SJO jacketed cord set	1	1	SPAS00021-L1J
non-monitored converter, 2-con style 6 cord sets	1	1	SPAS00021-L23
non-monitored converter, 2-con 3-pole cord sets	1	1	SPAS00021-L2F
non-monitored converter, 2-con style 1 SJO jacketed cord sets	1	1	SPAS00021-L2J
monitored converter, style 6 cord set	1	1	SPAS00021-M13
monitored converter, 3-pole cord set	1	1	SPAS00021-M1F
monitored converter, style 1 SJO jacketed cord set	1	1	SPAS00021-M1J
monitored converter, 2-con style 6 cord sets	1	1	SPAS00021-M23
monitored converter, 2-con 3-pole cord sets	1	1	SPAS00021-M2F
monitored converter, 2-con style 1 SJO jacketed cord sets	1	1	SPAS00021-M2J

C - Bottom Cover Assemblies	Quantity per		spare part code
	fitting	spare part	
EQ converter, style 6 cord set	1	1	SPAS00021-R13
EQ converter, 3-pole cord set	1	1	SPAS00021-R1F
EQ converter, style 1 SJO jacketed cord set	1	1	SPAS00021-R1J

Cord sets, 8-inch and 12-inch	Quantity per		spare part code
	fitting	spare part	
Cord set, L-823 style 1, 8" bottom pan	1 or 2	5	SP.73A0193/1
Cord set, L-823 style 1, 12" bottom pan	1 or 2	5	SP.73A0194/1
Cord set, L-823 style 6, 8" & 12" bottom pan	1 or 2	5	SPSGE96253351
Cord set, 3-pole, 8" & 12" bottom pan	1 or 2	5	SPSGEFR500160
Cable retaining clamp, for use with style 1 cord set	1 or 2	5	SP.MB00003-013-01
Ground lug kit	1	5	SP.72A0401

Prism spare parts, 8-inch and 12-inch	Quantity per		spare part code
	fitting	spare part	
Prism kit, taxiway, standard	1 or 2	2	SP.4072.40.412
Prism kit, taxiway reinforced	1 or 2	2	SP.4072.42.090

Screws and gaskets, 8-inch	Quantity per		spare part code
	fitting	spare part	
Pressure release screw with o-ring	1	5	SP.MF00090-000-01
Gasket, 8" Bottom pan	1	10	SP.MS00005-000-01
Screws, 8" Bottom pan	-	100	SP.MFPM5PT-714-01
Screws, light engine assembly mounting	-	100	SP.MFPM4PT-710-01

Wire harness, 8-inch and 12-inch	Quantity per		spare part code
	fitting	spare part	
Wire harness, power supply to light engine	1 or 2	10	SP.EW00070-150-01
Wire harness, power supply to heater	1 or 2	10	SP.EW00069-150-01

Fuse	Quantity per		spare part code
	fitting	spare part	
Fuse Resistors (only for fixtures with monitoring (M))	1 or 2	20	6132.00.250

i Note

All screws for fastening are included.

Component availability or design may be subject to change due to unforeseen circumstances. This document is subject to change or new information from ADB SAFEGATE, as and when available or if required, with reservation for error or price changes.

For more information or assistance with ordering spare parts, contact ADB SAFEGATE, see www.adbsafegate.com.

7.5 Spare Parts — Stop Bar Light FAA



NOTICE

- Each Top Cover Assembly includes a Bottom Cover Gasket and a Bottom Cover Screws.
- BAP stands for "Buy American Preference".

A1 - Top Cover Assemblies, 8-inch	Quantity per		spare part code
	fitting	spare part	
unidirectional straight, standard prism	1	1	SPAS00135-S1S
unidirectional straight, reinforced prism	1	1	SPAS00135-S1R
4-bolt unidirectional straight, standard prism	1	1	SPAS00135-S2S
4-bolt unidirectional straight, reinforced prism	1	1	SPAS00135-S2R

A2 - Top Cover Assemblies, 12-inch	Quantity per		spare part code
	fitting	spare part	
unidirectional straight, standard prism	1	1	SPAS00136-S1S
unidirectional straight, reinforced prism	1	1	SPAS00136-S1R

B1 & B2 - Light Engine Assembly, 8-inch and 12-inch	Quantity per		spare part code
	fitting	spare part	
red for L-852S(L) FAA stop bar and REL without heater	1	1	SPAS00089-SRR
red for L-852S(L) FAA stop bar and REL non-monitored (S-non-BAP) or monitored (M) with heater	1	1	SPAS00137-SRR-F
red for L-852S(L) FAA stop bar and REL non-monitored (S-BAP) or EQ (R) with heater	1	1	SPAS00137-SRR-E

C - Bottom Cover Assemblies, 8-inch and 12-inch	Quantity per		spare part code
	fitting	spare part	
non-monitored converter, style 6 cord set	1	1	SPAS00021-L13
non-monitored converter, style 1 SJO jacketed cord set	1	1	SPAS00021-L1J
monitored converter, style 6 cord set	1	1	SPAS00021-M13
monitored converter, style 1 SJO jacketed cord set	1	1	SPAS00021-M1J
EQ converter, style 6 cord set	1	1	SPAS00021-R13

C - Bottom Cover Assemblies, 8-inch and 12-inch	Quantity per		spare part code
	fitting	spare part	
EQ converter, style 1 SJO jacketed cord set	1	1	SPAS00021-R1J
Buy American Preference non-monitored converter, style 6 cord set	1	1	SPAS00021-S13
Buy American Preference non-monitored converter, style 1 SJO jacketed cord set	1	1	SPAS00021-S1J

Cord sets, 8-inch and 12-inch	Quantity per		spare part code
	fitting	spare part	
Cord set, L-823 style 1, 8" bottom pan	1 or 2	5	SP.73A0193/1
Cord set, L-823 style 1, 12" bottom pan	1 or 2	5	SP.73A0194/1
Cord set, L-823 style 6, 8" & 12" bottom pan	1 or 2	5	SP.SGE96253351
Cable retaining clamp, for use with style 1 cord set	1 or 2	5	SP.MB00003-013-01
Ground lug kit	1	5	SP.72A0401

Prism spare parts, 8-inch and 12-inch	Quantity per		spare part code
	fitting	spare part	
Prism kit, taxiway, standard	1 or 2	2	SP.4072.40.412
Prism kit, taxiway reinforced	1 or 2	2	SP.4072.42.090

Screws and gaskets, 8-inch	Quantity per		spare part code
	fitting	spare part	
Pressure release screw with o-ring	1	5	SP.MF00090-000-01
Gasket, 8" Bottom pan	1	10	SP.MS00005-000-01
Screws, 8" Bottom pan	-	100	SP.MFPM5PT-714-01
Screws, light engine assembly mounting	-	100	SP.MFPM4PT-710-01

Wire harness, 8-inch and 12-inch	Quantity per		spare part code
	fitting	spare part	
Wire harness, power supply to light engine	1 or 2	10	SP.EW00070-150-01
Wire harness, power supply to heater	1 or 2	10	SP.EW00069-150-01

Fuse	Quantity per		spare part code
	fitting	spare part	
Fuse resistors (only for fixtures with monitoring (M))	1 or 2	20	6132.00.250

 **Note**

All screws for fastening are included.

Component availability or design may be subject to change due to unforeseen circumstances. This document is subject to change or new information from ADB SAFEGATE, as and when available or if required, with reservation for error or price changes.

For more information or assistance with ordering spare parts, contact ADB SAFEGATE, see www.adbsafegate.com.

7.6 Spare Parts — Stop Bar Light ICAO



NOTICE

- Each Top Cover Assembly includes a Bottom Cover Gasket and a Bottom Cover Screws.
- BAP stands for "Buy American Preference".

A1 - Top Cover Assemblies, 8-inch	Quantity per		spare part code
	fitting	spare part	
unidirectional straight, standard prism	1	1	SPAS00135-S5S
unidirectional straight, reinforced prism	1	1	SPAS00135-S5R
unidirectional side 1 curved, standard prism	1	1	SPAS00135-S1S
unidirectional side 1 curved, reinforced prism	1	1	SPAS00135-S1R
unidirectional side 2 curved, standard prism	1	1	SPAS00135-C3S
unidirectional side 2 curved, reinforced prism	1	1	SPAS00135-C3R
bidirectional straight, standard prism	1	1	SPAS00135-S5S
bidirectional straight, reinforced prism	1	1	SPAS00135-S5R
bidirectional curved, standard prism	1	1	SPAS00135-C5S
bidirectional curved, reinforced prism	1	1	SPAS00135-C5R

A2 - Top Cover Assemblies, 12-inch	Quantity per		spare part code
	fitting	spare part	
unidirectional straight, standard prism	1	1	SPAS00136-S1S
unidirectional straight, reinforced prism	1	1	SPAS00136-S1R
unidirectional side 1 curved, standard prism	1	1	SPAS00136-C1S
unidirectional side 1 curved, reinforced prism	1	1	SPAS00136-C1R
unidirectional side 2 curved, standard prism	1	1	SPAS00136-C2S
unidirectional side 2 curved, reinforced prism	1	1	SPAS00136-C2R
bidirectional, straight, standard prism	1	1	SPAS00136-SBS
bidirectional, straight, reinforced prism	1	1	SPAS00136-SBR
bidirectional curved, standard prism	1	1	SPAS00136-CBS
bidirectional curved, reinforced prism	1	1	SPAS00136-CBR

B1 & B2 - Light Engine Assembly, 8-inch and 12-inch	Quantity per		spare part code
	fitting	spare part	
red wide without heater	1 or 2	1	SPAS00089-WRR-SB
red curved without heater	1 or 2	1	SPAS00089-CRR-SB
red wide EQ (R) with heater	1 or 2	1	SPAS00137-WRR-SBE
red curved EQ (R) with heater	1 or 2	1	SPAS00137-CRR-SBE
red wide non-monitored (S) or monitored (M) with heater	1 or 2	1	SPAS00137-WRR-SBF
red curved non-monitored (S) or monitored (M) with heater	1 or 2	1	SPAS00137-CRR-SBF

C - Bottom Cover Assemblies, 8-inch and 12-inch	Quantity per		spare part code
	fitting	spare part	
non-monitored converter, style 6 cord set	1	1	SPAS00021-L13
non-monitored converter, 3-pole cord set	1	1	SPAS00021-L1F
non-monitored converter, style 1 SJO jacketed cord set	1	1	SPAS00021-L1J
non-monitored converter, 2-con style 6 cord sets	1	1	SPAS00021-L23
non-monitored converter, 2-con 3-pole cord sets	1	1	SPAS00021-L2F
non-monitored converter, 2-con style 1 SJO jacketed cord sets	1	1	SPAS00021-L2J
monitored converter, style 6 cord set	1	1	SPAS00021-M13
monitored converter, 3-pole cord set	1	1	SPAS00021-M1F
monitored converter, style 1 SJO jacketed cord set	1	1	SPAS00021-M1J
monitored converter, 2-con style 6 cord sets	1	1	SPAS00021-M23
monitored converter, 2-con 3-pole cord sets	1	1	SPAS00021-M2F
monitored converter, 2-con style 1 SJO jacketed cord sets	1	1	SPAS00021-M2J
EQ converter, style 6 cord set	1	1	SPAS00021-R13
EQ converter, 3-pole cord set	1	1	SPAS00021-R1F
EQ converter, style 1 SJO jacketed cord set	1	1	SPAS00021-R1J

Cord sets, 8-inch and 12-inch	Quantity per		spare part code
	fitting	spare part	
Cord set, L-823 style 1, 8" bottom pan	1 or 2	5	SP73A0193/1
Cord set, L-823 style 1, 12" bottom pan	1 or 2	5	SP73A0194/1
Cord set, L-823 style 6, 8" & 12" bottom pan	1 or 2	5	SPSGE96253351
Cord set, 3-pole, 8" & 12" bottom pan	1 or 2	5	SPSGEFR500160
Cable retaining clamp, for use with style 1 cord set	1 or 2	5	SPMB00003-013-01
Ground lug kit	1	5	SP72A0401

Prism spare parts,	Quantity per		spare part code
	fitting	spare part	
Prism kit, taxiway, standard	1 or 2	2	SP4072.40.412
Prism kit, taxiway, reinforced	1 or 2	2	SP4072.42.090

Screws and gaskets	Quantity per		spare part code
	fitting	spare part	
Pressure release screw with o-ring	1	5	SPMF00090-000-01
Gasket, 8" Bottom pan	1	10	SPMS00005-000-01
Screws, 8" Bottom pan	-	100	SPMFPM5PT-714-01
Screws, light engine assembly mounting	-	100	SPMFPM4PT-710-01

Wire harness	Quantity per		spare part code
	fitting	spare part	
Wire harness, power supply to light engine	1 or 2	10	SPEW00070-150-01
Wire harness, power supply to heater	1 or 2	10	SPEW00069-150-01

Fuse	Quantity per		spare part code
	fitting	spare part	
Fuse resistors (only for fixtures with monitoring (M))	1 or 2	20	6132.00.250



Note

All screws for fastening are included.

Component availability or design may be subject to change due to unforeseen circumstances. This document is subject to change or new information from ADB SAFEGATE, as and when available or if required, with reservation for error or price changes.

For more information or assistance with ordering spare parts, contact ADB SAFEGATE, see www.adbsafegate.com.

7.7 Spare Parts — Taxiway Status, Takeoff/ Hold, Intersection and Entry Light



NOTICE

- Each Top Cover Assembly includes a Bottom Cover Gasket and a Bottom Cover Screws.
- BAP stands for "Buy American Preference".

A1 - Top Cover Assemblies, 8-inch	Quantity per		spare part code
	fitting	spare part	
unidirectional straight, standard prism	1	1	SPAS00135-S1S
unidirectional straight, reinforced prism	1	1	SPAS00135-S1R
4-bolt unidirectional straight, standard prism	1	1	SPAS00135-S2S
4-bolt unidirectional straight, reinforced prism	1	1	SPAS00135-S2R

A2 - Top Cover Assemblies, 12-inch	Quantity per		spare part code
	fitting	spare part	
unidirectional straight, standard prism	1	1	SPAS00136-S1S
unidirectional straight, reinforced prism	1	1	SPAS00136-S1R

B1 & B2 - Light Engine Assembly, 8-inch and 12-inch	Quantity per		spare part code
	fitting	spare part	
red for L-852S(L) FAA stop bar and REL (EQ or monitored) no heater	1	1	SPAS00089-SRR
red for L-852S(L) FAA stop bar and REL monitored (M) with heater	1	1	SPAS00137-SRR-F
red for L-852S(L) FAA stop bar and REL EQ (R) with heater	1	1	SPAS00137-SRR-E

C - Bottom Cover Assemblies, 8-inch and 12-inch	Quantity per		spare part code
	fitting	spare part	
monitored converter, style 6 cord set	1	1	SPAS00021-M13
monitored converter, style 1 SJO jacketed cord set	1	1	SPAS00021-M1J
EQ converter, style 6 cord set	1	1	SPAS00021-R13
EQ converter, style 1 SJO jacketed cord set	1	1	SPAS00021-R1R

Cord sets, 8-inch and 12-inch	Quantity per		spare part code
	fitting	spare part	
Cord set, L-823 style 1, 8" bottom pan	1 or 2	5	SP73A0193/1
Cord set, L-823 style 1, 12" bottom pan	1 or 2	5	SP73A0194/1
Cord set, L-823 style 6, 8" & 12" bottom pan	1 or 2	5	SPSGE96253351
Cable retaining clamp, for use with style 1 cord set	1 or 2	5	SPMB00003-013-01

Prism spare parts	Quantity per		spare part code
	fitting	spare part	
Prism kit, taxiway, standard	1 or 2	2	SP4072.40.412
Prism kit, taxiway reinforced	1 or 2	2	SP4072.42.090

Screws and Gaskets	Quantity per		spare part code
	fitting	spare part	
Pressure release screw with o-ring	1	5	SPMF00090-000-01
Gasket, 8" Bottom pan	1	10	SPMS00005-000-01
Screws, 8" Bottom pan	-	100	SPMFPM5PT-714-01
Screws, light engine assembly mounting	-	100	SPMFPM4PT-710-01

Wire harness	Quantity per		spare part code
	fitting	spare part	
Wire harness, power supply to light engine	1 or 2	10	SPEW00070-150-01
Wire harness, power supply to heater	1 or 2	10	SPEW00069-150-01

Fuse	Quantity per		spare part code
	fitting	spare part	
Fuse resistors (only for fixtures with monitoring (M))	1 or 2	20	6132.00.250



Note

All screws for fastening are included.

Component availability or design may be subject to change due to unforeseen circumstances. This document is subject to change or new information from ADB SAFEGATE, as and when available or if required, with reservation for error or price changes.

For more information or assistance with ordering spare parts, contact ADB SAFEGATE, see www.adbsafegate.com.

7.8 Spare Parts — Triple Line Taxiway Centerline Light

Appendix A: Winter Operations: Snow Plowing Guidelines for inset Lights

Introduction

Most ADB Safegate light fixtures are low protrusion height and the risk to damage the light is less than with fixtures that protrude higher above ground. Reinforced prisms are optional available for certain fixtures, further increasing the scratch resistance for enhanced lifetime. Nevertheless, airport winter operations play a crucial role in protecting in-pavement airfield ground lights from damage by snowplows.

Airport operators should follow the specifications:

- FAA AC 150/5200-30D - Airport Winter Safety and Operations
- FAA AC 150/5220-20A - Airport Snow and Ice Control Equipment
- FAA AC 150/5340-26C - Maintenance of Airport Visual Aid Facilities
- FAA EB85 - Ductile Snowplow Protection Ring And Installation Procedures
- ACRP Report 123 - A Guidebook for Airport Winter Operations

The following instructions provide a summary of these specifications and give additional guidelines, next to the airport specific and general rules, on damage prevention of airfield inset lights during winter operations.

Anti- and De-icing Chemicals

Chemicals may be required to remove compacted snow from in-pavement light fixtures. However, extensive chemical use may damage in-pavement light fixtures and underground electrical components resulting in additional electrical maintenance requirements and costs. De-icing liquids should be used moderately; excessive use will have a negative impact on the environment and will contaminate the light outlet.

ADB Safegate light fixtures are tested to work with common chemicals on the airfield such as:

- Potassium Acetate
- Potassium Formate
- Sodium Acetate
- Sodium Formate

The pH value of such chemical solutions should not exceed pH 11 to protect the light fixtures from corrosion and other damage.

Winter Operation Training

Most airports conduct dry-run winter operations training in advance of the winter season. Winter operation tests and simulations should be performed on designated and suitable sections of taxiways or runways equipped with the fittings to be tested. This will help to identify any potential problems and will avoid excessive damages on luminaries and maintenance vehicles during winter.

Snow and Ice Removal

To prevent damage of in-pavement lights during snow and ice removal a combination of different techniques should be used.

- In-pavement **lights should be turned on** at maximum intensity approx. 30-40 min. before the start of snow and ice removal. The purpose is to ensure melting of snow and ice formation at the light outlets before snow and ice removal.
- Anti-icing chemicals may be used to prevent ice bonding to the pavement surface. Once the ice has bonded to the pavement surface, approved de-icing chemicals may be used to melt through the ice pack and/or to break up or weaken the ice bond.
- For actual removal snowplows, rotary runway brooms and blowers should be used in combination. By principle:
 - **Snowplows** should be used with the plow blade set at a small distance from the pavement surface for removal of the majority of snow and ice.



Note

Refer to the [Cutting Edge Height](#) paragraph of the [Snowplows](#) section.

—**Rotary runway brooms** are more effective at removing snow from in-pavement lighting fixtures than plow blades and should be used for removal of the last layer.

- If snow removal is a frequent winter job, the use of **high-strength steel snowplow rings** is advised to better withstand the impact of snow plowing and to protect aluminum alloy in-pavement lights. Please refer to FAA Engineering Brief 85 for further information concerning design and installation of snowplow rings.
-

Important

The most effective counter-measures in case of damages to in-pavement lights are to slightly increase the plow blade/cutting edge height above ground and reduction of snowplow speed.

Snowplows

Material and Structure of the Cutting Edge

To protect in-pavement lights from damage during the snow removal it is important that the snowplows are equipped with plastic cutting edges.

- The plastic cutting edge should be made of polyurethane, rubber or material of similar consistence and characteristics.
- The plastic cutting edge should consist of a minimum of plastic segments, accurately aligned and free of steps between them.

Figure 34: Fig. 1 — Snowplow blade with well aligned segments



- It is not recommended to have steps between the plastic segments.
- Vertical or horizontal steps between the plastic segments will increase the risk of luminaire damage. Hitting inset fixtures with steps between plastic segments should be avoided.
- Check regularly for wear and abrasion marks on plastic cutting edges.
- The plastic cutting edges should be replaced when worn down to the wear limit marking. Wear down to the metal portion of the plow should be avoided in any case.

Figure 35: Fig. 2 — Snowplow blade with wear and steps between segments



Cutting Edge Height

- In order to prevent damage to in-pavement lights and to protect vehicle operators from uneven pavement joints and edges, the plow blade / cutting edge should be set slightly above ground level.
- In a stationary position the clearance between the plastic cutting edge and the pavement should be 10 to 15 mm. Any remaining snow/ice should be removed with rotary brooms and/or de-icing or anti-freeze agent. No clearance between the plastic cutting edge and the pavement may damage in-pavement lights.

Figure 36: Fig. 3 — Snowplow blade without clearance



- Use casters, shoes and/or support wheels on plow moldboards and on the front of rotary plows to stabilize the plow blade and to support maintaining a pre-defined clearance between the snowplow cutting edge and the pavement during operation.

Figure 37: Fig. 4 — Snowplow with support wheels



Figure 38: Fig. 5 — Snowplow without support wheels



- Do not use guidance and support wheels that are made of steel.
- Any protruding bolts and metal elements whose clearance to pavement is less than 20 mm during operation shall be avoided

Speed and angle of the plow

High snowplow speeds can damage the light outlets and prisms could eventually break. The allowable speed should be determined before start of operation, based on the configuration of the equipment.

- A speed of greater 40 km per hour is not advised.
- Whenever snowplows must traverse over in-pavement light fixtures, they should be traveling at less than 10 km per hour or should lift the blades clear of the fixture.
- Some plow blades are made of a series of movable segments. These segments are spring loaded and are able to move vertical to follow uneven pavement. Do not block blade segment mechanics which allow for such movement.
- Adjust and regularly control plow angles as per manufacturer recommendation.
- If frequent prism damages exist during the winter operations it may be necessary to reduce the snowplow's swivel angle versus the driving line of the vehicle.
- Different temperatures and snow quantities influence the parameters described. Applied settings need to follow supplier recommendations.

Rotary brooms

Rotary runway brooms can be used for both snow and ice removal:

- **Snow** — Rotary runway brooms are more effective at removing snow from in-pavement light fixtures than plow blades.
- **Ice** — The type of brooms used to remove a layer of ice is important since in some cases the broom may actually "polish" the ice, thus reducing traction.

Bristles for rotary brooms are available as steel or poly bristles.

- Steel bristles cut the ice surface while, poly bristles flip / wipe away snow. However, using steel bristles will faster scratch and wear out especially the glass prisms of in-pavement lights, negatively impacting the light photometry.
- When possible avoid using steel bristles, or run rotary brooms with a mix of steel and poly bristles (e.g. 1/3) to reduce the wear and damage to in-pavement lights.
- Check for adequate contact pressure; evaluate during pre-winter dry-run tests.
- Check for bristle wear according to manufacturers recommendation and replace the brooms when necessary. If worn down the bristles will be more stiff and will increase the wear on the light fixtures and especially the prisms significantly.
- When possible avoid using silica or glass sand. If necessary to use, remove it as soon as operational conditions allow. When removing sand use caution with rotating brushes (rotate at low speed).
- Use of reinforced prisms, which are about four times as hard as regular glass prisms, can significantly increase the prism maintenance interval, though scratches will still occur over time.

Steel brushes:

- The use of steel brushes is very effective for snow removal, it is however very important to pay special attention on how it is being used and replace the brushes when they are worn to make sure that the brushes are not too rigid and risk decreasing the service life of the prisms.

Tip

We recommend the use of "sapphire"TM prism which is about four times harder than a regular glass prism if steel brushes are used.

The use of sapphire prisms will not make the prisms scratch proof as scratches can still occur over time but it will increase the service interval and service life of the prism.

Appendix B: INTEROPERABILITY

Base installation – O-ring selection and retaining bolts 12-inch

For 12-inch light fixtures the O-ring is required. Refer to data sheet for ordering code for corresponding 12-inch base.

Table 2: Interoperability matrix — 12 inch

Base type	Required O-ring	Bolt installation	Stud installation		
		Required dimension	Recommended torque	Required nut	Recommended torque
<ul style="list-style-type: none"> • RELIANCE 12-in/150 mm, Safegate 12-in/150 mm • ERNI 12-in ED12-190 	O-ring D259, 3×5,7 (7080.90.650) SP.013114/10pc SP.013115/100pc	1411.20.482 Metric screw kit 12-in M10×22 mm	40 Nm + locking washer (max height 2mm)	1411.20.500 Self-locking nut kit 12-in M10 H=100	35 Nm
<ul style="list-style-type: none"> • Thorn 12-in 150 mm • Thorn 12-in 100 mm 	O-ring D259, 3×5,7 (7080.90.650) SP.013114/10pc SP.013115/100pc	1411.20.482 Metric screw kit 12-in M10×25 mm	40 Nm + locking washer (max height 2mm) *only with non-roll over lights	1411.20.500 Metric nut kit 12-in M10 H=100	35 Nm
<ul style="list-style-type: none"> • L-868 deep can 	O-ring D259, 3×5,7 (7080.90.650) SP.013114/10pc SP.013115/100pc	1411.20.452 UNC screw kit	reference EB83	N/A	N/A
<ul style="list-style-type: none"> • ADB 12-in Eurobase 	O-ring D259, 3×5,7 (7080.90.650) SP.013114/10pc SP.013115/100pc	1411.20.482 Metric screw kit 12-in M10×22 mm	21 Nm + Loctite 2701 or 638	1411.20.500 Self-locking nut kit 12-in M10 H=100	21 Nm + Loctite 2701 or 638

Table 3: Interoperability matrix — 8 inch

Base type	Required O-ring	Bolt installation		Stud installation	
		Required dimension	Recommended torque	Required nut	Recommended torque
<ul style="list-style-type: none"> • ERNI 8-in EE08 (150 mm) • ERNI 8-in ED08 (133 mm) 	Blue O-Ring (SGE48001263) SGE.SP24521/10 pc SGE.SP24524/100 pc	1411.20.522 Metric screw kit 8" 25 mm	40 Nm + Locking washer (max height 2mm)	1411.20.430 Self-locking nut kit H100	35 Nm
<ul style="list-style-type: none"> • Thorn 8-in 100 mm • Thorn 8" 133 mm • Thorn 8-in MK2 133 mm • IDM 6494 (120 mm) 	Red O-Ring (SGE48001298) SGE.SP24523/10 pc SGE.SP24526/100 pc	1411.20.522 Metric screw kit 8" 25 mm	40 Nm + Locking washer (max height 2mm)	1411.20.430 Self-locking nut kit H100	35 Nm
<ul style="list-style-type: none"> • ADB 8-in Eurobase • Adapter ring ADB 8-in-12-in 	Blue O-Ring (SGE48001263) SGE.SP242521/10 pc SGE.SP24524/100 pc	1411.20.522 Metric screw kit 8" 25 mm	21 Nm + Loctite 2701 or 638	1411.20.430 Self-locking nut kit 8" H100	21 Nm ¹
<ul style="list-style-type: none"> • ADB 8-in HPI 	Grey O-Ring (SGE48001264) SGE.SP24522/10 pc SGE.SP24525/100 pc	1411.20.522 Metric screw kit 25 mm	21 Nm + Loctite 2701 or 638	1411.20.430 Self-locking nut kit H100	21 Nm ¹
<ul style="list-style-type: none"> • Adapter ring SG/Thorn/ID 8-in-12-in 	Red O-Ring (SGE48001298) SGE.SP24523/10 pc SGE.SP24526/100 pc	1411.20.522 Metric screw kit 25 mm	40 Nm + Locking washer (max height 2mm)	1411.20.430 Self-locking nut kit H100	35 Nm

Notes

¹ Do not use Loctite or washer with self-locking nut.



CAUTION

Use of incorrect combination of gaskets, bolts and nuts can create severe damages to the product installation and create multiple safety risks.

To obtain a safe and watertight installation the O-ring and retaining bolt stated in the document must be used.

You need to know what base the light fixture will be installed in, in order to choose the correct gasket, bolts and nuts.

Failure to follow these cautions can result in equipment damage or aircraft FOD.



Appendix C: POWER TABLE

L-852A(L), L-852B(L), L-852C(L), L-852D(L), L-852J(L), L-852K(L)

(TA-TB-TC-TD-TJ-TK), 8- and 12-inch **without** Arctic Kit

Fixture type – 1 cord set ¹	Fixture load	Isolation transformer		CCR load
		Wattage	Load	
Taxiway Centerline L-852(L), bidirectional	16.5 VA	15 W	7.9 VA	24.4 VA
Taxiway Centerline, L-852(L), unidirectional	14.3 VA	15 W	8.51 VA	22.8 VA

Fixture type – 1 cord set ¹	Fixture load	Isolation transformer		CCR load
		Wattage	Load	
Taxiway Centerline, L-852(L), bidirectional	55.1 VA	65 W	18.6 VA	73.7 VA
Taxiway Centerline, L-852(L), unidirectional	40.1 VA	45 W	13.8 VA	53.9 VA

Notes

¹ Values provided are for the "S" option non-monitored power only.

LED Taxiway Centerline ICAO

(TC-TK-TC-TR-TW ICAO), 8- and 12-inch **without** Arctic Kit

Fixture type – 1 cord set ¹	Fixture load	Isolation transformer		CCR load
		Wattage	Load	
Taxiway Centerline Wide, bidirectional	13.5 VA	15 W	7.6 VA	21.1 VA
Taxiway Centerline Curved, bidirectional	12.4 VA	15 W	7.6 VA	20 VA
Taxiway Centerline Narrow, unidirectional	7.8 VA	15 W	10.1 VA	18 VA

Fixture type – 2 cord sets ¹	Fixture load		Isolation transformer				CCR load	
	Side 1	Side 2	Wattage		Load		Side 1	Side 2
			Side 1	Side 2	Side 1	Side 2		
Taxiway Centerline Narrow, bidirectional	10.9 VA	10.9 VA	15 W	15 W	7.9 VA	7.9 VA	18.6 VA	18.8 VA
Taxiway Centerline Wide, bidirectional	13.1 VA	13.1 VA	15 W	15 W	7.7 VA	7.7 VA	20.8 VA	20.8 VA

Notes

¹ Values provided are for the "S" option non-monitored power only.

Appendix D: CABLE LOSS

The cable resistance R (ohms) for 1 conductor is calculated with following formula:

- $R \text{ (ohms)} = \text{resistivity of material (ohm m)} \times \text{length (m)} / \text{cross sectional area (m}^2\text{)}$
- For copper conductors the resistivity is $1.72 \times 10^{-8} \text{ (m}^2\text{)}$

Example; for 1 km 2.5 mm^2 copper conductor, the resistance R is calculated as follows:

$$1.72 \times 10^{-8} \times 1000 / 2.5 \times 10^{-6} \text{ m}^2 = 6.88 \text{ ohms}$$

The loss (Watt) is then $R \times I^2$ or $6.88 \text{ ohms} \times 6.6^2 \text{ A}^2 = 299.69 \text{ W/km}$ or 0.299 W/m .

The loss (Watt) for a secondary cable with 2 conductors is thus $2 \times 0.299 = 0.599$ or 0.6 W/m .

As such we can calculate:

- Secondary cable for a 2.5 mm^2 Cu-wire (2 conductors): 0.6 W/m
- Secondary cable for a 4 mm^2 Cu-wire (2 conductors): 0.4 W/m
- Primary cable for a 6 mm^2 Cu-wire (1 conductor): 0.12 W/m

The cable between the isolation transformer and the lamp adds losses that cannot be ignored when dimensioning the circuits and selecting rating for secondary transformers and regulators.



WARNING

Cable lengths should not exceed 100 meters.

For a secondary cable of e.g., 20 m of 2.5 mm^2 CU-wire, $20 \text{ m} \times 0.6 \text{ W/m} = 12 \text{ W}$ equals the additional loss to be taken into account.

For a primary cable of e.g., 100 m of 6 mm^2 CU-wire, $100 \text{ m} \times 0.12 \text{ W/m} = 12 \text{ W}$ equals the additional loss to be taken into account.

Appendix E: SUPPORT

Our experienced engineers are available for support and service at all times, 24 hour/7 days a week. They are part of a dynamic organization making sure the entire ADB SAFEGATE is committed to minimal disturbance for airport operations.

ADB SAFEGATE Support

Live Technical Support - Americas

If at any time you have a question or concern about your product, just contact ADB SAFEGATE's technical service department. Trained in all areas of system issues, troubleshooting, quality control and technical assistance, our highly experienced Technical support specialists are available 24 hours a day, seven days a week to provide assistance over the phone.

ADB SAFEGATE **Americas Technical Service & Support (US & Canada): +1-800-545-4157**

ADB SAFEGATE Americas Technical Service & Support (International): +1-614-861-1304

During regular business hours, you can also Chat with a Service Technician. We look forward to working with you!

Before You Call

When you have an airfield lighting or system control system problem it is our goal to support airfield maintenance staff as quickly as possible. To support this effort we ask that you have the following information ready before calling.

- The *airport code*
- If not with an airport, then company name (prefer customer id number)
- Contact phone number and email address
- Product with part number preferable or product number
- Have you reviewed the product's manual and troubleshooting guide
- Do you have a *True RMS* meter available (and any other necessary tools)
- Be located with the product ready to troubleshoot

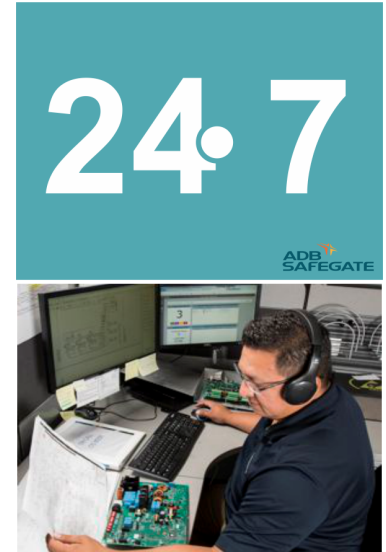

Note

For more information, see www.adbsafegate.com, or contact ADB SAFEGATE Support via email at support@adbsafegate.com or

Brussels: +32 2 722 17 11

Rest of Europe: +46 (0) 40 699 17 40

Americas: +1 614 861 1304. Press 3 for technical service or press 4 for sales support.

China: +86 (10) 8476 0106

E.1 ADB SAFEGATE Website

The ADB SAFEGATE website, www.adbsafegate.com, offers information regarding our airport solutions, products, company, news, links, downloads, references, contacts and more.

E.2 Recycling

E.2.1 Local Authority Recycling

The disposal of ADB SAFEGATE products is to be made at an applicable collection point for the recycling of electrical and electronic equipment. The correct disposal of equipment prevents any potential negative consequences for the environment and human health, which could otherwise be caused by inappropriate waste handling. The recycling of materials helps to conserve natural resources. For more detailed information about recycling of products, contact your local authority city office.

E.2.2 ADB SAFEGATE Recycling

ADB SAFEGATE is fully committed to environmentally-conscious manufacturing with strict monitoring of our own processes as well as supplier components and sub-contractor operations. ADB SAFEGATE offers a recycling program for our products to all customers worldwide, whether or not the products were sold within the EU.

ADB SAFEGATE products and/or specific electrical and electronic component parts which are fully removed/separated from any customer equipment and returned will be accepted for our recycling program.

All items returned must be clearly labeled as follows:

- For *ROHS/WEEE* Recycling
- Sender contact information (Name, Business Address, Phone number).
- Main Unit Serial Number.

ADB SAFEGATE will continue to monitor and update according for any future requirements for *EU directives* as and when *EU member states* implement new *regulations* and or *amendments*. It is our aim to maintain our *compliance plan* and assist our customers.

Company Addresses

ADB SAFEGATE, Belgium	ADB SAFEGATE BV Leuvensesteenweg 585, B-1930 Zaventem Belgium
Contact: Tel.: +32 2 722 17 11 Fax: +32 2 722 17 64	Email: marketing@adbsafegate.com Internet: www.adbsafegate.com
ADB SAFEGATE, Americas	ADB SAFEGATE Americas LLC 977 Gahanna Parkway, Columbus, OH 43230 USA
Contact: Tel.: +1 (614) 861 1304 Fax: +1 (614) 864 2069	Email: sales.us@adbsafegate.com Internet: www.adbsafegate.com
ADB SAFEGATE, Sweden	ADB SAFEGATE Sweden AB Djurhagegatan 19 SE-213 76 Malmö Sweden
Contact: Tel.: +46 (0)40 699 17 00 Fax: +46 (0)40 699 17 30	Email: marketing@adbsafegate.com Internet: www.adbsafegate.com
ADB SAFEGATE, China	ADB SAFEGATE Airfield Technologies Ltd. China Unit 603, D Block, CAMIC International Convention Center, No 3, Hua Jia Di East road, ChaoYang district, Beijing 100102 P.R. China
Contact: Tel.: +86 (10) 8476 0106 Fax: +86 (10) 8476 0090	Email: china@safegate.com Internet: www.adbsafegate.com
ADB SAFEGATE, Germany	ADB SAFEGATE Germany GmbH Konrad-Zuse-Ring 6, D-68163 Mannheim Germany
Contact: Tel.: +49 (621) 87 55 76-0 Fax: +49 (621) 87 55 76-55	Email: marketing@adbsafegate.com Internet: www.adbsafegate.com



Powering Your Airport Performance from Approach to Departure

adbsafegate.com

Copyright © ADB SAFEGATE, all rights reserved

