



L-880 and L-881 PAPI, Style B
Precision Approach Path Indicator (Current Powered)

User Manual

96A0236, Rev. V, 2023/02/02



A.0 Disclaimer / Standard Warranty

CE certification

The equipment listed as CE certified means that the product complies with the essential requirements concerning safety and hygiene. The European directives that have been taken into consideration in the design are available on written request to ADB SAFEGATE.

ETL certification

The equipment listed as ETL certified means that the product complies with the essential requirements concerning safety and FAA Airfield regulations. The FAA directives that have been taken into consideration in the design are available on written request to ADB SAFEGATE.

All Products Guarantee

ADB SAFEGATE will correct by repair or replacement per the applicable guarantee above, at its option, equipment or parts which fail because of mechanical, electrical or physical defects, provided that the goods have been properly handled and stored prior to installation, properly installed and properly operated after installation, and provided further that Buyer gives ADB SAFEGATE written notice of such defects after delivery of the goods to Buyer. Refer to the Safety section for more information on Material Handling Precautions and Storage precautions that must be followed.

ADB SAFEGATE reserves the right to examine goods upon which a claim is made. Said goods must be presented in the same condition as when the defect therein was discovered. ADB SAFEGATE further reserves the right to require the return of such goods to establish any claim.

ADB SAFEGATE's obligation under this guarantee is limited to making repair or replacement within a reasonable time after receipt of such written notice and does not include any other costs such as the cost of removal of defective part, installation of repaired product, labor or consequential damages of any kind, the exclusive remedy being to require such new parts to be furnished.

ADB SAFEGATE's liability under no circumstances will exceed the contract price of goods claimed to be defective. Any returns under this guarantee are to be on a transportation charges prepaid basis. For products not manufactured by, but sold by ADB SAFEGATE, warranty is limited to that extended by the original manufacturer. This is ADB SAFEGATE's sole guarantee and warranty with respect to the goods; there are no express warranties or warranties of fitness for any particular purpose or any implied warranties of fitness for any particular purpose or any implied warranties other than those made expressly herein. All such warranties being expressly disclaimed.

Standard Products Guarantee

Products manufactured by ADB SAFEGATE are guaranteed against mechanical, electrical, and physical defects (excluding lamps) which may occur during proper and normal use for a period of two years from the date of ex-works delivery, and are guaranteed to be merchantable and fit for the ordinary purposes for which such products are made.



Note

See your applicable sales agreement for a complete warranty description.

Replaced or repaired equipment under warranty falls into the warranty of the original delivery. No new warranty period is started for these replaced or repaired products.

FAA Certified products manufactured by ADB SAFEGATE

ADB SAFEGATE L858 Airfield Guidance Signs are warranted against mechanical and physical defects in design or manufacture for a period of 2 years from date of installation, per FAA AC 150/5345-44 (applicable edition).

ADB SAFEGATE LED products (with the exception of obstruction lighting) are warranted against electrical defects in design or manufacture of the LED or LED specific circuitry for a period of 4 years from date of installation, per FAA EB67 (applicable edition). These FAA certified constant current (series) powered LED products must be installed, interfaced and powered with and through products certified under the FAA Airfield Lighting Equipment Program (ALECP) to be included in this 4 (four) year warranty. This includes, but is not limited to, interface with products such as Base Cans, Isolation Transformers, Connectors, Wiring, and Constant Current Regulators.



Note

See your sales order contract for a complete warranty description.

Replaced or repaired equipment under warranty falls into the warranty of the original delivery. No new warranty period is started for these replaced or repaired products.

Liability



WARNING

Use of the equipment in ways other than described in the catalog leaflet and the manual may result in personal injury, death, or property and equipment damage. Use this equipment only as described in the manual.

ADB SAFEGATE cannot be held responsible for injuries or damages resulting from non-standard, unintended uses of its equipment. The equipment is designed and intended only for the purpose described in the manual. Uses not described in the manual are considered unintended uses and may result in serious personal injury, death or property damage.

Unintended uses, includes the following actions:

- Making changes to equipment that have not been recommended or described in this manual or using parts that are not genuine ADB SAFEGATE replacement parts or accessories.
- Failing to make sure that auxiliary equipment complies with approval agency requirements, local codes, and all applicable safety standards if not in contradiction with the general rules.
- Using materials or auxiliary equipment that are inappropriate or incompatible with your ADB SAFEGATE equipment.
- Allowing unskilled personnel to perform any task on or with the equipment.

© ADB SAFEGATE SWEDEN AB

This manual or parts thereof may not be reproduced, stored in a retrieval system, or transmitted, in any form or by any means, electronic, mechanical, photocopying, recording, nor otherwise, without ADB SAFEGATE SWEDEN AB's prior written consent.

This manual could contain technical inaccuracies or typographical errors. ADB SAFEGATE SWEDEN AB reserves the right to revise this manual from time to time in the contents thereof without obligation of ADB SAFEGATE SWEDEN AB to notify any person of such revision or change. Details and values given in this manual are average values and have been compiled with care. They are not binding, however, and ADB SAFEGATE SWEDEN AB disclaims any liability for damages or detriments suffered as a result of reliance on the information given herein or the use of products, processes or equipment to which this manual refers. No warranty is made that the use of the information or of the products, processes or equipment to which this manual refers will not infringe any third party's patents or rights. The information given does not release the buyer from making their own experiments and tests.

© ADB SAFEGATE BV

This manual or parts thereof may not be reproduced, stored in a retrieval system, or transmitted, in any form or by any means, electronic, mechanical, photocopying, recording, nor otherwise, without ADB SAFEGATE BV's prior written consent.

This manual could contain technical inaccuracies or typographical errors. ADB SAFEGATE BV reserves the right to revise this manual from time to time in the contents thereof without obligation of ADB SAFEGATE BV to notify any person of such revision or change. Details and values given in this manual are average values and have been compiled with care. They are not binding, however, and ADB SAFEGATE BV disclaims any liability for damages or detriments suffered as a result of reliance on the information given herein or the use of products, processes or equipment to which this manual refers. No warranty is made that the use of the information or of the products, processes or equipment to which this manual refers will not infringe any third party's patents or rights. The information given does not release the buyer from making their own experiments and tests.

TABLE OF CONTENTS

1.0 Safety	1
1.1 Safety Messages	1
1.1.1 Introduction to Safety	2
1.1.2 Intended Use	2
1.1.3 Material Handling Precautions: Storage	3
1.1.4 Operation Safety	3
1.1.5 Maintenance Safety	3
2.0 L-880 & L-881 PAPI, Style B	5
2.1 About this manual	5
2.2 How to work with the manual	5
3.0 PAPI B Overview	7
3.1 Precision Approach Path Indicator	7
3.2 Type L-880 PAPI System	8
3.3 Type L-881 PAPI System	10
3.4 PAPI Light Unit	11
3.4.1 Lamps	11
3.4.2 Reflector Panel	11
3.4.3 Filter Panel	11
3.4.4 Lens Panels	11
3.4.5 Lens Shield	11
3.4.6 Adjustable Mounting Legs	12
3.5 Theory of Operation	12
3.5.1 General	12
3.5.2 Heater	13
3.5.3 Tilt Switch	13
3.6 Style B L-880/L-881 PAPI: Required Equipment	13
3.7 Style B L-880/L-881 PAPI Specifications	15
3.7.1 Transmission Factor of Red Sector	15
3.7.2 Transmission Sector	15
3.7.3 Visual Acquisition Range	15
3.7.4 Tilt Switch	15
3.7.5 Mean Time Between Failures	15
3.7.6 Mounting Provisions	15
3.7.7 Photometrics	15
3.8 Digital Protractor Specifications	16
3.8.1 Range	16
3.8.2 Resolution	16
3.8.3 Accuracy	16
3.8.4 Repeatability	16
3.8.5 Supply Voltage	16
3.8.6 Battery Life	16
3.8.7 Temperature	16
3.8.8 Weight	16
4.0 Installation	17
4.1 Unpacking	17
4.2 Instruments for Installation and Verification	17
4.2.1 Installation Using Bubble-Level Style Aiming Device	17
4.2.2 Introduction to Installation Using Digital-Level Style Aiming Device	18
4.2.3 Installation Using Digital-Level Style Aiming Device	19
4.3 Siting Considerations	20
4.3.1 Distance of PAPI Units from Runway Edge	20
4.3.2 Lateral Spacing of PAPI Units	20
4.4 Siting PAPI with ILS Glideslope	20

4.5 Siting PAPI on Runways Without ILS	21
4.5.1 Threshold Crossing Height (TCH)	21
4.5.2 Glideslope Angle	21
4.5.3 Distance of PAPI from Threshold	21
4.5.4 Obstacle Clearance Surface	22
4.5.5 Reduction of Beam Coverage for Obstacle Avoidance	23
4.6 Siting Tolerances	23
4.6.1 Azimuthal Aiming	23
4.6.2 Mounting Height Tolerance	23
4.6.3 PAPI Tolerance Along Line Perpendicular to Runway	23
4.6.4 Correction for Runway Longitudinal Gradient	24
4.7 Additional Siting Considerations	25
4.8 PAPI Foundations	26
4.9 PAPI Aiming Angles	35
4.10 Assembling Adjustable Legs	35
4.11 Mounting Unit	35
4.12 Aligning Units	37
4.12.1 How Bubble-Level Aiming Device Works	38
4.12.2 How Digital-Level Aiming Device Works	38
4.13 Digital Aiming Device	38
4.13.1 Calibrating Digital Protractor	40
4.13.2 Performing Digital Protractor Accuracy Test	41
4.13.3 Performing Digital Protractor Calibration Procedure	42
4.13.4 Installing Digital Protractor Batteries	44
4.13.5 Aligning PAPI Using Bubble-Level/Digital-Level Aiming Devices	45
4.13.6 Aligning Horizontal Cut-Offs to Aiming Device	45
4.14 Adjusting Rough Elevation Setting	46
4.14.1 Adjusting Rough Elevation Setting for Four-Leg PAPI System	46
4.14.2 Adjusting Rough Elevation Setting for Three-Leg PAPI System	46
4.14.3 Adjusting Rough Elevation Setting for Three-Leg PAPI System	47
4.15 Checking Horizontal Aiming	47
4.16 Adjusting Fine Elevation Setting	47
4.16.1 Adjusting Fine Elevation Setting for Four-Leg PAPI System	47
4.16.2 Adjusting Fine Elevation Setting for Three-Leg PAPI System	48
4.16.3 Adjusting Fine Elevation Setting for Three-Leg PAPI System (contd.)	48
4.17 Leveling Tilt Switch	48
4.18 Connecting Series Circuit	48
4.18.1 Grounding Units	48
4.18.2 Using Isolation Transformers	48
4.18.3 Connecting External Wiring	49
4.19 Checking Slope Angles of PAPI Units	50
4.20 Using Reference Bases for Checking Stick	50
4.20.1 Locating Reference Bases	50
4.20.2 Making Observations with Checking Stick	51
4.20.3 Making Flight Checks for Reduced Horizontal Coverage	51
5.0 Operation	53
5.1 Operating PAPI System	53
5.1.1 Normal Operation	53
5.1.2 Regions with Heavy Snowfall	53
5.1.3 Criteria for System Deactivation	53
5.2 Operating Digital Protractor	53
5.3 Wiring Schematics and Installation Drawings	54
6.0 Maintenance	59
6.1 Maintenance Schedule	59
6.2 Maintenance Procedures	60
6.2.1 Replacing Lamp	60
6.2.2 Replacing Objective Lens	61
6.2.3 Replacing Filters	61
6.2.4 Cleaning and Storing Digital Protractor	61

7.0 Troubleshooting	63
8.0 PAPI B Parts	65
8.1 Style B L-880/L-881 PAPI Part Numbering System	65
8.2 Optical Box Final Assembly Parts List	66
8.3 Optical Assembly Parts List	67
8.4 Adjustable Leg Parts	69
8.5 Field Splice Kit Parts List	70
8.6 PAPI B Spare Parts	72
A.0 SUPPORT	73
A.1 ADB SAFEGATE Website	73
A.2 Recycling	74
A.2.1 Local Authority Recycling	74
A.2.2 ADB SAFEGATE Recycling	74

List of Figures

Figure 1: L-880 Four-Box PAPI System	7
Figure 2: L-881 Two-Box PAPI System	7
Figure 3: PAPI Obstacle Clearance Surface	8
Figure 4: L-880 Signal Display	9
Figure 5: L-881 Signal Display	10
Figure 6: PAPI Light Unit	11
Figure 7: Adjustable Mounting Legs	12
Figure 8: Checking Stick	18
Figure 9: Side View of Digital-Level Aiming Device for Two-Lamp PAPI	19
Figure 10: Top View of Digital-Level Aiming Device for Two-Lamp PAPI	20
Figure 11: Obstacle Clearance Surface	22
Figure 12: Correction for Runway Longitudinal Gradient	24
Figure 13: Relocating PAPI Units	25
Figure 14: Installation on Concrete Pad (Two-Lamp, Three-Leg PAPI)	26
Figure 15: Installation on Concrete Pad (Two-Lamp, Four-Leg PAPI)	27
Figure 16: Installation on Concrete Pad (Three-Lamp, Three-Leg PAPI)	28
Figure 17: Installation on Concrete Pad (Three-Lamp, Four-Leg PAPI)	29
Figure 18: Positioning Plate (Two Lamps/Three Legs)	30
Figure 19: Positioning Plate (Two Lamps/Four Legs)	31
Figure 20: Positioning Plate (Three Lamps/Three Legs)	32
Figure 21: Positioning Plate (Three Lamps/Four Legs)	33
Figure 22: Frangible Coupling	34
Figure 23: Elevation Setting Sequence (Two-Lamp, Four-Leg PAPI Shown)	36
Figure 24: Elevation Setting Sequence (Two-Lamp, Three-Leg PAPI Shown)	37
Figure 25: Positioning Digital Protractor	41
Figure 26: Rotating and Rolling Protractor	41
Figure 27: Digital Protractor Displays and Buttons	42
Figure 28: O within Flashing Brackets	42
Figure 29: Rotating and Rolling Digital Protractor for Horizontal Settings	43
Figure 30: Rotating and Rolling Digital Protractor for Vertical Settings	44
Figure 31: Digital Protractor	44
Figure 32: PAPI External Connections (Two- and Three-Lamp)	49
Figure 33: Checking Slope Angles	50
Figure 34: Digital Protractor Initial Angle Displayed	53
Figure 35: PAPI Style B Master and Slave Typical Installation 3-Lamp External Wiring	54
Figure 36: PAPI Style B Master and Slave Typical Installation 2-Lamp External Wiring	55

Figure 37: PAPI Style B Master and Slave Typical Installation	55
Figure 38: PAPI Style B Master and Slave Three-leg Foundation Detail	56
Figure 39: PAPI Style B Master and Slave Four-leg Foundation Detail	57
Figure 40: Two- and Three-Lamp PAPI Optical Box Internal Wiring	58
Figure 41: Optical Box Parts and Details	66
Figure 42: Optical Box Part Detail B-B	66
Figure 43: Optical Box Parts Detail C-C, E-E	67
Figure 44: Optical Box Side View	68
Figure 45: Adjustable Leg 43C2362/SS	69
Figure 46: Frangible Coupling 44B0180	70
Figure 47: Field Splice Kit 94A0255/X	71

List of Tables

Table 1: L-880 PAPI Required Equipment Supplied	13
Table 2: L-881 PAPI Required Equipment SuppliedTable	13
Table 3: L-880/L-881 Required Equipment Not Supplied	13
Table 4: Required Transformers for 6.6 A Series Circuit Installation	14
Table 5: Required Transformers for 20 A Series Circuit Installation	14
Table 6: Contractor-Supplied Connectors, Conduit, Cable, and Bushings	14
Table 7: Threshold Crossing Height	21
Table 8: Aiming Angles for L-880 PAPI Units	35
Table 9: Aiming Angles for L-881 PAPI Units	35
Table 10: Conversion from Decimal Degrees to Minutes	39
Table 11: Locating Wiring Schematics	54
Table 12: PAPI Maintenance	59
Table 13: Style B L-880/L-881 PAPI Troubleshooting	63
Table 14: Style B L-880/L-881 Optical Box Assembly Part Numbers	65
Table 15: Lamp Reflector Assembly Parts	67
Table 16: Splice Kit Parts	70
Table 17: Aiming Device Kit Parts List	71
Table 18: PAPI-B Spare Parts	72

1.0 Safety

Introduction to Safety







This section contains general safety instructions for installing and using ADB SAFEGATE equipment. Some safety instructions may not apply to the equipment in this manual. Task- and equipment-specific warnings are included in other sections of this manual where appropriate.

1.1 Safety Messages

HAZARD Icons used in the manual

For all HAZARD symbols in use, see the Safety section. All symbols must comply with ISO and ANSI standards.

Carefully read and observe all safety instructions in this manual, which alert you to safety hazards and conditions that may result in personal injury, death or property and equipment damage and are accompanied by the symbol shown below.

	<p>WARNING Failure to observe a warning may result in personal injury, death or equipment damage.</p>
	<p>DANGER - Risk of electrical shock or ARC FLASH Disconnect equipment from line voltage. Failure to observe this warning may result in personal injury, death, or equipment damage. ARC Flash may cause blindness, severe burns or death.</p>
	<p>WARNING - Wear personal protective equipment Failure to observe may result in serious injury.</p>
	<p>WARNING - Do not touch Failure to observe this warning may result in personal injury, death, or equipment damage.</p>
	<p>CAUTION Failure to observe a caution may result in equipment damage.</p>
	<p>ELECTROSTATIC SENSITIVE DEVICES This equipment may contain electrostatic devices.</p>

Qualified Personnel

	<p>Important Information The term qualified personnel is defined here as individuals who thoroughly understand the equipment and its safe operation, maintenance and repair. Qualified personnel are physically capable of performing the required tasks, familiar with all relevant safety rules and regulations and have been trained to safely install, operate, maintain and repair the equipment. It is the responsibility of the company operating this equipment to ensure that its personnel meet these requirements. Always use required personal protective equipment (PPE) and follow safe electrical work practice.</p>
-------------------------------------------------------------------------------------	-----------------------------------------------------------------------------------------------------------------------------------------------------------------------------------------------------------------------------------------------------------------------------------------------------------------------------------------------------------------------------------------------------------------------------------------------------------------------------------------------------------------------------------------------------------------------------------------------------------------------------------------------------------

1.1.1 Introduction to Safety



CAUTION

Unsafe Equipment Use

This equipment may contain electrostatic devices, hazardous voltages and sharp edges on components

- Read installation instructions in their entirety before starting installation.
- Become familiar with the general safety instructions in this section of the manual before installing, operating, maintaining or repairing this equipment.
- Read and carefully follow the instructions throughout this manual for performing specific tasks and working with specific equipment.
- Make this manual available to personnel installing, operating, maintaining or repairing this equipment.
- Follow all applicable safety procedures required by your company, industry standards and government or other regulatory agencies.
- Install all electrical connections to local code.
- Use only electrical wire of sufficient gauge and insulation to handle the rated current demand. All wiring must meet local codes.
- Route electrical wiring along a protected path. Make sure they will not be damaged by moving equipment.
- Protect components from damage, wear, and harsh environment conditions.
- Allow ample room for maintenance, panel accessibility, and cover removal.
- Protect equipment with safety devices as specified by applicable safety regulations
- If safety devices must be removed for installation, install them immediately after the work is completed and check them for proper functioning prior to returning power to the circuit.

Failure to follow this instruction can result in serious injury or equipment damage

Additional Reference Materials



Important Information

- IEC - International Standards and Conformity Assessment for all electrical, electronic and related technologies.
- IEC 60364 - Electrical Installations in Buildings.
- FAA Advisory: AC 150/5340-26 (current edition), Maintenance of Airport Visual Aid Facilities.
- Maintenance personnel must refer to the maintenance procedure described in the ICAO Airport Services Manual, Part 9.
- ANSI/NFPA 79, Electrical Standards for Metalworking Machine Tools.
- National and local electrical codes and standards.

1.1.2 Intended Use



CAUTION

Use this equipment as intended by the manufacturer

This equipment is designed to perform a specific function, do not use this equipment for other purposes

- Using this equipment in ways other than described in this manual may result in personal injury, death or property and equipment damage. Use this equipment only as described in this manual.

Failure to follow this instruction can result in serious injury or equipment damage

1.1.3 Material Handling Precautions: Storage



CAUTION

Improper Storage

Store this equipment properly

- If equipment is to be stored prior to installation, it must be protected from the weather and kept free of condensation and dust.

Failure to follow this instruction can result in equipment damage

1.1.4 Operation Safety



CAUTION

Improper Operation

Do Not Operate this equipment other than as specified by the manufacturer

- Only qualified personnel, physically capable of operating the equipment and with no impairments in their judgment or reaction times, should operate this equipment.
- Read all system component manuals before operating this equipment. A thorough understanding of system components and their operation will help you operate the system safely and efficiently.
- Before starting this equipment, check all safety interlocks, fire-detection systems, and protective devices such as panels and covers. Make sure all devices are fully functional. Do not operate the system if these devices are not working properly. Do not deactivate or bypass automatic safety interlocks or locked-out electrical disconnects or pneumatic valves.
- Protect equipment with safety devices as specified by applicable safety regulations.
- If safety devices must be removed for installation, install them immediately after the work is completed and check them for proper functioning.
- Route electrical wiring along a protected path. Make sure they will not be damaged by moving equipment.
- Never operate equipment with a known malfunction.
- Do not attempt to operate or service electrical equipment if standing water is present.
- Use this equipment only in the environments for which it is rated. Do not operate this equipment in humid, flammable, or explosive environments unless it has been rated for safe operation in these environments.
- Never touch exposed electrical connections on equipment while the power is ON.

Failure to follow these instructions can result in equipment damage

1.1.5 Maintenance Safety



DANGER

Electric Shock Hazard

This equipment may contain electrostatic devices

- Do not operate a system that contains malfunctioning components. If a component malfunctions, turn the system OFF immediately.
- Disconnect and lock out electrical power.
- Allow only qualified personnel to make repairs. Repair or replace the malfunctioning component according to instructions provided in its manual.

Failure to follow these instructions can result in death or equipment damage

2.0 L-880 & L-881 PAPI, Style B

L-880 & L-881 PAPI, Style B, Current Powered, manual.

2.1 About this manual

The manual shows the information necessary to:

- Install
- Carry Out Maintenance
- Carry Out Troubleshooting on the L-880 & L-881 PAPI, Style B.ti

2.2 How to work with the manual

1. Become familiar with the structure and content.
2. Carry out the actions completely and in the given sequence.

3.0 PAPI B Overview

See [Figure 1](#) and [Figure 2](#). This section describes the Style B, L-880 and L-881 Precision Approach Path Indicator (PAPI) systems used to provide visual approach path guidance to pilots of landing aircraft.

Figure 1: L-880 Four-Box PAPI System

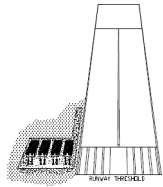

The PAPI Style B is designed to operate from an L-828 constant current regulator (CCR) with a maximum output current of 6.6 A. When used on a 20 A series lighting circuit, a 20 A isolation transformer must be used to step the current down to 6.6 A. The CCR controls the brightness of the PAPI system. The CCR may have three or five brightness steps.

Figure 2: L-881 Two-Box PAPI System

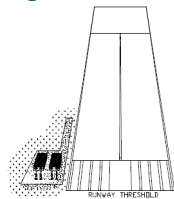

3.1 Precision Approach Path Indicator

Uses

A PAPI system uses either 2-light channel or 3-light channel units, which offer the pilot information to carry out the approach procedure with the utmost accuracy and safety.

The L-880 PAPI system consists of four light units located at the side of the runway adjacent to the origin of the glide path. The nominal glide slope angle is midway between the angular settings of the central pair of the four units. If an aircraft is on the correct approach path, the pilot will see two red and two white light indicators.

If the aircraft approach is too high, an increased number of white light indicators will be seen. If the approach is too low, the pilot will note an increased number of red light indicators. The L-881 PAPI system is identical to the L-880, except only two light units (instead of four) are used. The nominal glide slope is midway between the angular settings of the two units, and when the pilot is on or close to the correct approach path, the unit nearest the runway will be seen as red and the other unit as white.

The Style A system is for use with either a 220 or 240 VAC input voltage. The Style B system is for use on 6.6 or 20 A series circuits. A tilt switch assembly is provided on each PAPI unit to de-energize the system in the case that the optical pattern of any light unit is raised between 0.5° and 1.0° or lowered between 0.25° and 0.5° with respect to the setting angle of the unit.

Electrical Supply

Style A ¹	
Input Voltage: 220-240 VAC ± 10% (VA max.) ²	
L-880 (4-box) 2-lamps/optical box	1,800
L-880 (4-box) 3-lamps/optical box	2,700
L-881 (2-box) 2-lamps/optical box	1,650
L-881 (2-box) 3-lamps/optical box	1,650
Style B	
Two Lamp – 6.6 A through one 500 W isolation transformer	

L-880 (4-Box) – Total CCR Load ³	1960 VA maximum
L-881 (2-Box) – Total CCR Load ³	980 VA maximum
Three Lamp – 6.6 A through one 500 W and one 200 W isolation transformer	
L-880 (4-Box) – Total CCR Load ³	3,160 VA maximum
L-881 (2-Box) – Total CCR Load ³	1,580 VA maximum

Notes

- ¹ Limit on distance from Master to first light unit is 100 ft (30.5 m)
- ² As seen at input of PAPI Master
- ³ Includes PAPI light units and isolation transformers

3.2 Type L-880 PAPI System

See Figures Figure 1, Figure 3, and Figure 4. The L-880 PAPI system consists of four identical light units that are normally installed on the left side of the runway (viewed from the approach end) in a line perpendicular to the runway centerline. See also FAA AC 150-5340-30 diagram of the same name.

Figure 3: PAPI Obstacle Clearance Surface

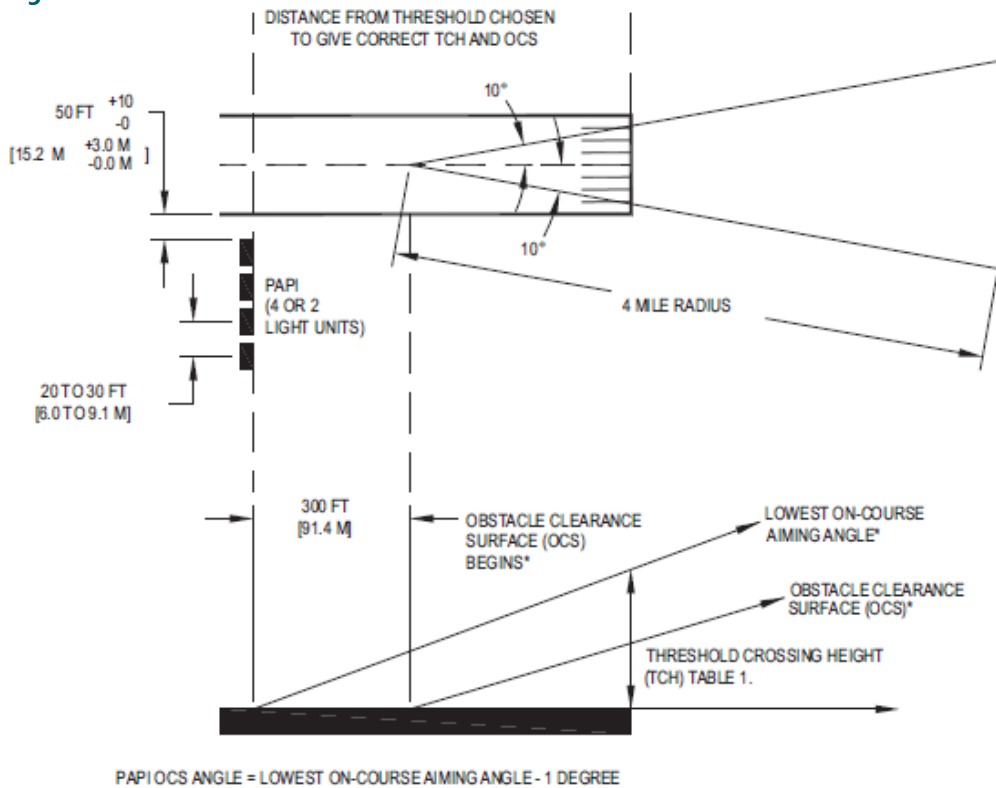
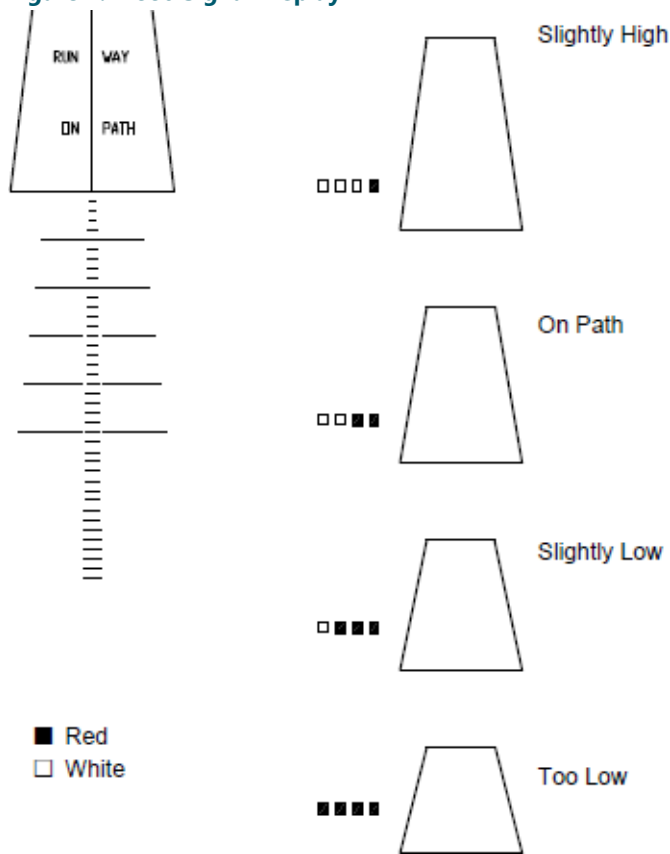

Figure 4: L-880 Signal Display



The units are aimed so that during a landing approach the pilot will see the following signal format:

- The inner two units as red and the outer two units as white when the aircraft is close to or on the approach slope.
- The unit nearest the runway as red and the three units farthest from the runway as white when above the approach slope; all four units appear white if the aircraft is excessively above the approach slope.
- The three units closest to the runway are seen as red and the unit farthest from the runway as white if the aircraft is slightly below the approach slope; and still further below, all the units will appear red.

3.3 Type L-881 PAPI System

See [Figure 2](#), [Figure 3](#), and [Figure 5](#). The L-881 PAPI system consists of two identical light units that are normally installed on the left side of the runway (viewed from the approach end) in a line perpendicular to the runway centerline.

Figure 5: L-881 Signal Display

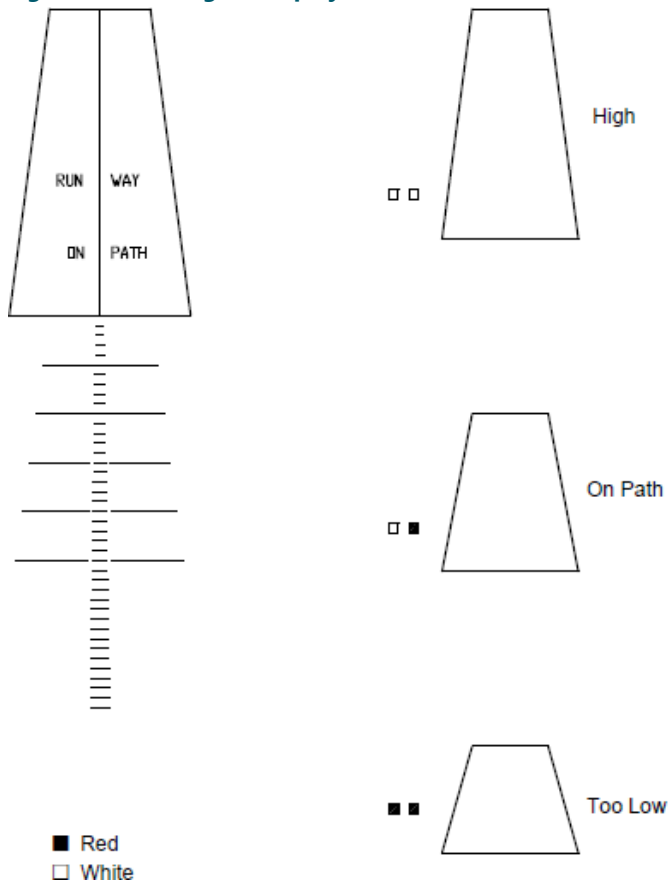

The units are aimed so that during a landing approach the pilot will see the following signal format:

- Both units as red when the aircraft is below the approach slope Too Low
- The unit nearest the runway as red and the other unit as white when on or close to the approach slope
- Both units as white when the aircraft is above the approach slope

3.4 PAPI Light Unit

See [Figure 6](#) . This subsection describes the PAPI light unit parts. A single PAPI light unit contains two or three 6.6 A, 200 W lamps, two or three reflectors and red filters, four or six lenses, a lens shield, a printed circuit board, and a tilt switch assembly. The PAPI unit is mounted on three or four adjustable legs.

Figure 6: PAPI Light Unit

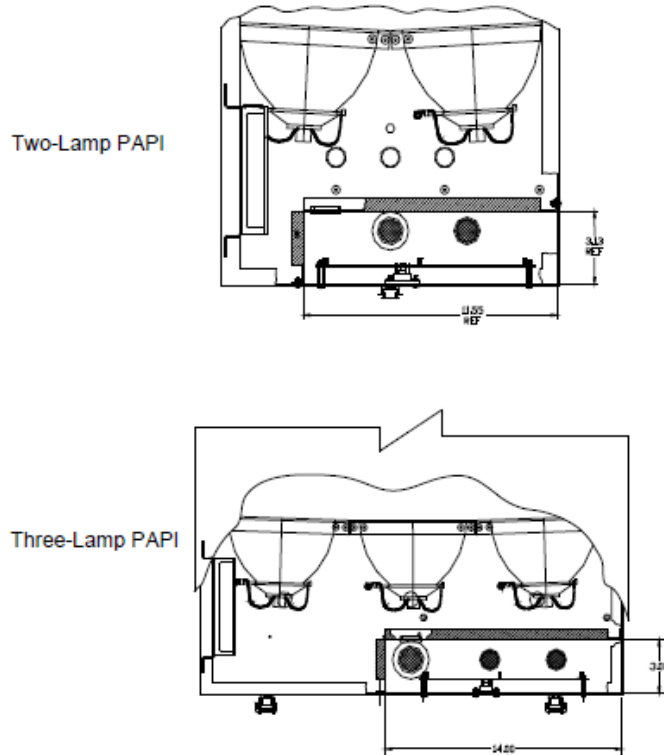

3.4.1 Lamps

Two or three 200-watt pre-focused halogen lamps are located in the rear of the unit, each in an indexed lamp holder in a reflector and held in place with a forked spring clip. Slip-on type electrical connections permit easy replacement of failed lamps.

3.4.2 Reflector Panel

The reflector panel is fitted with two apertures in which the elliptical reflectors are housed. The reflectors are made of aluminum that is mechanically polished for brilliance and anodized for protection.

3.4.3 Filter Panel

The filter panel houses the two or three red filters. It also has two reference slots, C and D, used to locate the aiming device for making field adjustments of the light unit. These reference slots are precision machined in the factory. Be careful not to damage these machined slots.

3.4.4 Lens Panels

Four or six high optical quality objective lenses are housed in two lens panels. The upper rim of the front lens panel is equipped with two reference blocks, A and B, for field adjustment of the light unit. These blocks are precision-adjusted in the factory to be parallel with the optical centerline of the objective lenses.

3.4.5 Lens Shield

The flat glass shield (protective glass) serves to protect the lenses against materials such as sand and stone, and is designed to avoid reflections.

3.4.6 Adjustable Mounting Legs

See Figure 7 . The three or four adjustable mounting legs are each made up of two screw rods connected by a differential sleeve . The upper (smaller diameter) rod is fitted with nuts and locking nuts designed for coarse height setting of the unit.

i Note

For the three-leg PAPI, the rear center leg is installed into an existing rivnut and fixed with a locking nut.

The differential sleeve is used for the fine adjustment setting of the unit. The lower (larger diameter) rod is inserted into a conduit column with frangible coupling held in place by a flange bolted on a concrete pad.

Figure 7: Adjustable Mounting Legs

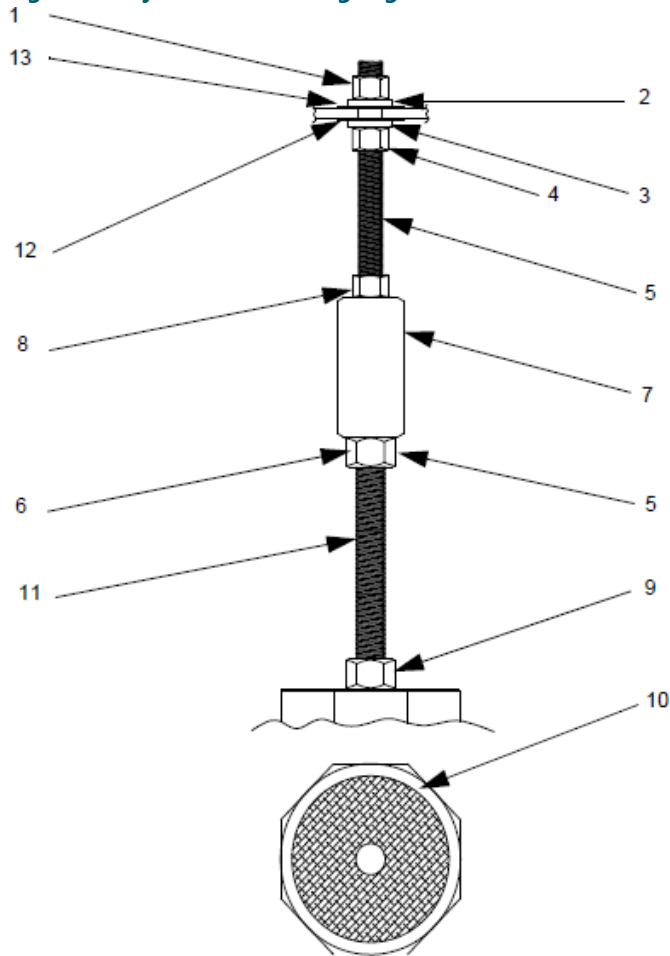

1. Upper Hex Nut	5. 3/8–16 x 6 All Thread	9. 1/2–13 Hex Nut
2. Upper 3/8 Split Lock washer	6. Locking Hex Nut	10. Leg Cap
3. Lower 3/8 Split Lock washer	7. Differential	11. 1/2–13 x 5 All Thread
4. Lower Hex Nut 3/8–16	8. Locking Hex Nut 3/8–16	12. Lower 3/8 Flat washer
		13. Upper 3/8 Flat washer

3.5 Theory of Operation

This section describes the L-880/L-881 PAPI system theory of operation. It includes operations of the heater and tilt switch.

3.5.1 General

The PAPI Style B power is supplied from a 6.6 A or 20 A series circuit.

See “Wiring Schematics and Installation Drawings” on page 67. If using two 200 W lamps, then a 500 W isolation transformer supplies power to the PCB and both lamps to connect J1. If using a 3-lamp box, then a 200 W isolation transformer powers the third lamp to connect J2. If any PAPI unit is tilted, the tilt switch circuit is activated, which causes the lamps to de-energize after a nominal 16-second delay. The PAPI system cannot be re-energized until all the PAPI units are in proper alignment.

3.5.2 Heater

See “Wiring Schematics and Installation Drawings” on page 67. Thermostat TH1 in the PCB is used to supply 6.6 A to the heater. When the inside air temperature drops below 0 °F, the thermostat turns on. This causes 6.6 A current to flow into the heater resistors R1 in the tilt switch boxes. This prevents the mercury in the tilt switches from freezing.

3.5.3 Tilt Switch

See “Wiring Schematics and Installation Drawings” on page 67. The tilt switch circuit is designed so that the tilt switches are a closed circuit as long as they are not inadvertently lowered more than 1/4 degree or raised more than 1/2 degree with respect to the preset aiming angle. If a tilt switch is moved from proper alignment, the tilt switch will de-energize all lamps after a nominal 16-second time delay. The PAPI system cannot be re-energized until all the PAPI units are in proper alignment.

3.6 Style B L-880/L-881 PAPI: Required Equipment

Refer to [Table 1](#) and [Table 2](#) for required equipment that is supplied. Refer to [Table 3](#) for required equipment that is not supplied. Refer to the *Parts* section for ordering information.

Table 1: L-880 PAPI Required Equipment Supplied

Description	Quantity
PAPI lamp assembly	4
Field splice kit	4
Instruction manual	1 per order

Table 2: L-881 PAPI Required Equipment Supplied

Description	Quantity
PAPI lamp assembly	2
Field splice kit	2
Instruction manual	1 per order

Table 3: L-880/L-881 Required Equipment Not Supplied

Description	Quantity	Note
Constant current regulator	1	
Aiming device kit	1	One required per airport.
Positioning plate	1	See Figure 1 through Figure 6 in the <i>Installation</i> section.
Isolation transformers	As required	Refer to Table 4 and Table 5 .
Primary connector kit	4 for L-880 2 for L-881	Used to connect transformers to series circuit. Supplied by contractor.
Survey instrument	1	Used to locate light units
L-867 base plate, 1 hub	As required	One L-867 base plate is required for the L-867 base near each slave and master unit.
L-867 base can (optional)	As required	One L-867 base can per light box.
1-1/2 inch x 1- 1/4 inch hex reducer bushing	As required	Supplied by contractor. Refer to Table 6 for quantities.

Table 3: L-880/L-881 Required Equipment Not Supplied (Continued)

Description	Quantity	Note
1-1/4 inch flex conduit/liquid tight w/1-1/4 male straight connector	As required	Supplied by contractor. Refer to Table 6 for quantities.
Interconnecting cable (2-conductor)	As required	Used for tilt switch circuit. Supplied by contractor. Refer to Table 6
Single primary cable	As required	Used to connect transformers. Supplied by contractor. Refer to Table 6 .
Concrete	As required	

Table 4: Required Transformers for 6.6 A Series Circuit Installation

PAPI System	L-830-6 Transformer (200 W)	500 W Transformer
L-880 (2-lamp)	0	4
L-880 (3-lamp)	4	4
L-881 (2-lamp)	0	2
L-881 (3-lamp)	2	2

Table 5: Required Transformers for 20 A Series Circuit Installation

PAPI System	L-830-7 Transformer	500 W Transformer
L-880 (2-lamp)	0	4
L-880 (3-lamp)	4	4
L-881 (2-lamp)	0	2
L-881 (3-lamp)	2	2

Table 6: Contractor-Supplied Connectors, Conduit, Cable, and Bushings

Description	L-880 PAPI	L-881 PAPI
1-1/4 flex conduit male connector	8	4
1-1/2 x 1-1/4 hex reducer bushing	4	2
1-1/4 conduit/liquid tight (length as required)	4	2
Single primary cable	As required	As required
Interconnector cable (2-conductor)	As required	As required

3.7 Style B L-880/L-881 PAPI Specifications

This subsection describes the specifications for the Style B L-880 (four-box) and L-881 (two-box) PAPI systems. Refer to [PAPI B Parts](#).

3.7.1 Transmission Factor of Red Sector

At least 15%

3.7.2 Transmission Sector

Three minutes of arc over full beam spread

3.7.3 Visual Acquisition Range

7.1 miles within an approach envelope of ± 5 degrees from the approach axis

3.7.4 Tilt Switch

De-energizes all lamps in the PAPI system if optical pattern of any light unit is raised more than $1/2$ degree or lowered more than $1/4$ degree.

3.7.5 Mean Time Between Failures

5000 hours (minimum) between failures for all components (excluding lamps)

3.7.6 Mounting Provisions

Three or four mounting legs

3.7.7 Photometrics

Each light unit used in the L-880/L-881 PAPI systems has two/three lamps and provides a beam of light split horizontally to produce white light in the top sector and red light in the bottom sector. When viewed by an observer at a distance of 1000 feet (304.8 m), the transition from red light to white light occurs within an angle of three minutes of arc at the beam center and within an angle of five minutes of arc at the beam edges.

3.8 Digital Protractor Specifications

This subsection provides specifications for the optional digital protractor used to aim the PAPI.

3.8.1 Range

Range is 360 degrees (90 degrees x 4).

3.8.2 Resolution

Resolution is 0.01 degree (0 to 9.99 degrees).

Resolution is 0.10 degree (10 to 90 degrees).

3.8.3 Accuracy

Refer below for digital protractor accuracy.

- ± 0.05 degree (0 to 10 degrees)
- ± 0.10 degree (80 to 90 degrees)
- ± 0.20 degree (10 to 80 degrees)

3.8.4 Repeatability

Repeatability is ± 0.05 degree.

3.8.5 Supply Voltage

9 volt alkaline battery

3.8.6 Battery Life

500 hours typical

3.8.7 Temperature

Operating temperature: -5 to 50 °C (23 to 122 °F)

Storage temperature: -20 to 65 °C (-4 to 149 °F)

3.8.8 Weight

Weight is 295 g (10.4 oz)

4.0 Installation



WARNING

Electric Shock

Read installation instructions in their entirety before starting installation.

- Become familiar with the general safety instructions in this section of the manual before installing, operating, maintaining or repairing this equipment.
- Read and carefully follow the instructions throughout this manual for performing specific tasks and working with specific equipment.
- Allow only qualified personnel to perform the following tasks. Observe and follow the safety instructions in this document and all other related documentation.

Failure to follow these warnings may result in serious injury or equipment damage.

This section provides instructions for the installation of the PAPI system. Refer to the airport project plans and specifications for the specific installation instructions.

4.1 Unpacking

Handle equipment very carefully to prevent component damage. Note any exterior damage to the crate that might lead to detection of equipment damage. If you note any damage to any equipment, file a claim with the carrier immediately. The carrier may need to inspect the equipment.

4.2 Instruments for Installation and Verification

This subsection provides information about the instruments necessary to install the PAPI.

4.2.1 Installation Using Bubble-Level Style Aiming Device

The instruments below are required for installing, leveling, setting, and checking the elevation setting of the light units using the bubble-level style aiming device:

- One bubble-level style aiming device for azimuth and elevation setting.
- One precision bubble level for leveling the units.
- One checking stick for routine checks of the elevation setting.

Bubble-Level Style Aiming Device

The bubble-level style aiming device consists of:

- One base to rest on reference block B and slot C, and two movable arms to rest on reference block A and slot D.
- Two graduated scales for elevation setting.
- One bar used for the longitudinal horizontal reference required to set both azimuth and elevation.

Bubble Level

This instrument has a 0.004 in/ft (0.3 mm/m) degree of precision which allows a very precise setting (within one minute of arc) compatible with the design precision of the PAPI light unit.

Checking Stick

The checking stick is used to make routine checks of the elevation setting of the PAPI units. It consists of a small transparent screen attached to a lightweight rod. The screen has two horizontal lines 23 mm (0.90 in.) apart to correspond to approximately 3 minutes of arc at 25 m (82 ft). Refer to *Reference Bases for Checking Stick* in this section for instructions on using the checking stick.

Figure 8: Checking Stick

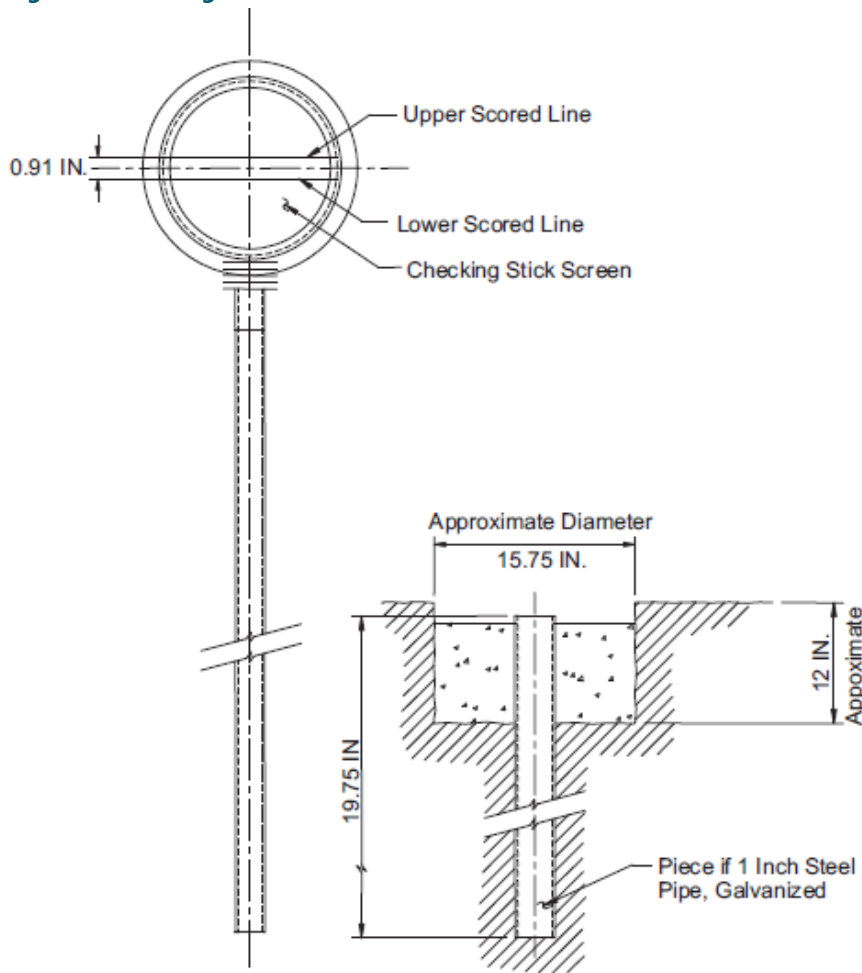

4.2.2 Introduction to Installation Using Digital-Level Style Aiming Device

The instruments below are required for installing, leveling, setting, and checking the elevation setting of the light units using the digital-level style aiming device.

- One digital-level style aiming device for azimuth and elevation setting
- One precision digital protractor for leveling the units and setting the tilt switch



CAUTION

Digital-Level device protractor must be calibrated before each use to insure accuracy. See "Calibrating Digital Protractor"

4.2.3 Installation Using Digital-Level Style Aiming Device

The instruments below are required for installing, leveling, setting, and checking the elevation setting of the light units using the digital-level style aiming device.

- one digital-level style aiming device for azimuth and elevation setting
- one precision digital protractor for leveling the units and setting the tilt switch

Digital-Level Style Aiming Device

See [Figure 9](#) and [Figure 10](#) for the digital-level aiming device. The digital-level style aiming device consists of the following:

- One base to rest on reference block B and slot C, and long arms to rest on reference block A.
- One bar used for the longitudinal horizontal reference required to set both azimuth and elevation.

Note [Figure 9](#) and [Figure 10](#) show the aiming device on the two-lamp PAPI. These figures also apply to the three-lamp PAPI.

Figure 9: Side View of Digital-Level Aiming Device for Two-Lamp PAPI



The two movable arms increase the stability of the aiming device and are used to establish the transverse horizontal references. Screws are provided on the bar and on the movable arms to guarantee an exact positioning of the level during setting and adjustment. This exact positioning is required to have a perfect match between the level and the longitudinal and transverse horizontal references. The two V-sights on the bar of the aiming device are for azimuth alignment.

Figure 10: Top View of Digital-Level Aiming Device for Two-Lamp PAPI

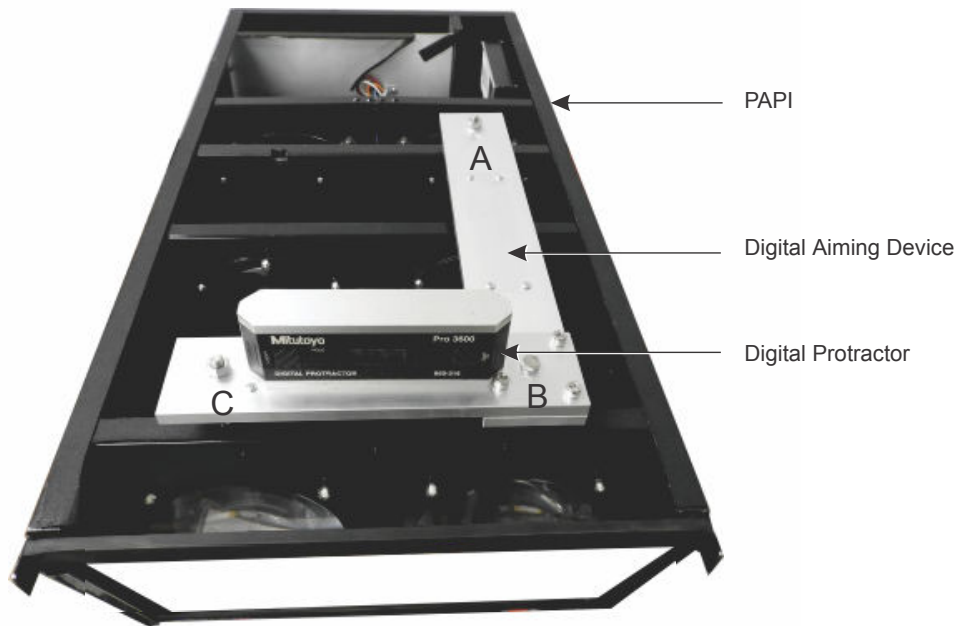

Digital Protractor

For information on the digital protractor, refer to *How Digital-Level Aiming Device Works* in this section and *Operating Digital Protractor* in the Operation section.

4.3 Siting Considerations

When viewed from the approach end, the PAPI system shall be located on the left-hand side of the runway as shown in [Figure 3](#). The PAPI may be located on the right side of the runway if siting problems exist, such as conflicts with runways or taxiways. The PAPI must be sited and aimed so that it defines an approach path with adequate clearance over obstacles and a minimum threshold crossing height.

If the runway has an established ILS glideslope, refer to *Siting PAPI with ILS Glideslope* in this section. The PAPI must be installed so that the visual glideslope coincides (as much as possible) with the electronic glideslope. If there is no ILS on the runway, refer to *Siting PAPI on Runways Without an ILS* in this section. The PAPI's glideslope must be chosen to ensure the on-course signal of the PAPI provides adequate clearance over obstacles.

4.3.1 Distance of PAPI Units from Runway Edge

See [Figure 3](#). The light unit nearest to the runway shall be no closer than 50 feet (15.24 m) (+10, -0 feet) (+3.048, -0 m) from the runway edge or to other runways or taxiways. This distance may be reduced to 30 feet (9.144 m) for small general aviation runways used by non-jet aircraft.

4.3.2 Lateral Spacing of PAPI Units

The PAPI units shall have a spacing between units of 20 to 30 feet (6.096 to 9.144 m). The distance between boxes shall not vary by more than 1 foot (304.8 mm).

4.4 Siting PAPI with ILS Glideslope

When a runway has an established ILS electronic glideslope, the PAPI on-slope signal should coincide, as much as possible, with that for the ILS. To accomplish this, place the PAPI at the same distance (tolerance of ± 30 feet or ± 9.144 m) from the threshold as the virtual source of the ILS glideslope and aim at the same angle as the ILS glideslope.

Refer to [Table 7](#) . This procedure must be modified for runways that serve aircraft in height group 4 because of the eye-to-antenna distance. For these runways, the distance of the PAPI from the threshold shall equal the distance to the virtual source of the ILS glideslope plus an additional 300 feet (91.44 m) (+50 ft, -0 ft) (+15.24 m, -0 m). Calculations should be performed to ensure that the site chosen provides adequate obstacle clearance and threshold crossing height.

Table 7: Threshold Crossing Height

Type of Aircraft	Cockpit-to-Wheel Height	Visual Threshold Crossing Height	Remarks
Height Group 1 (General aviation, small commuters, corporate turbojets)	10 feet (3.048 m) or less	40 feet (12.2 m) (+5 ft, -20 ft) (+1.524 m, -6.1 m)	Many runways less than 6,000 ft (1828.8 m) long with reduced widths and/or restricted weight bearing which would normally prohibit landings by larger aircraft
Height Group 2 (F-28, CV-340/440/580, B-737, DC-8/9)	15 feet (4.6 m)	45 feet (13.7 m) (+5 ft, -20 ft) (+1.524 m, -6.1 m)	Regional airport with limited air carrier service
Height Group 3 (B-707/720/727/757)	20 feet (6.1 m)	50 feet (15.24 m) (+5 ft, -15 ft) (+1.524 m, -4.6 m)	Primary runways not normally used by aircraft with ILS glideslope-to-wheel heights exceeding 20 ft (6.1 m)
Height Group 4 (B-747/767, L-1011, DC-10, A-300)	Over 25 feet (7.6 m)	75 feet (22.9 m) (+5 ft, -15 ft) (+1.524 m, -4.6 m)	Most primary runways at major airports.

4.5 Siting PAPI on Runways Without ILS

When the runway doesn't have an ILS glideslope, the PAPI must be sited and aimed so that it defines an approach path which will produce the required threshold crossing height and clearance over any obstacles in the approach area.

4.5.1 Threshold Crossing Height (TCH)

See [Figure 3](#) . The TCH is the height of the lowest on-course signal at a point directly above the threshold and the runway centerline. The minimum allowable TCH depends on the height group of the aircraft using the runway, and is shown in [Table 7](#) . The glideslope of the PAPI must provide the proper TCH for the most demanding aircraft height group using the runway.

4.5.2 Glideslope Angle

The standard visual glideslope angle for the PAPI is 3 degrees. For non-jet runways, this may be raised to 4 degrees if required to provide obstacle clearance.

4.5.3 Distance of PAPI from Threshold

The following method can be used to determine the PAPI installation distance from the runway threshold provided there are no obstacles in the area from which the PAPI signals can be observed, no differences in elevation between the threshold and the installation zone of the PAPI or between the units, or reduced length of runway. The distance of the PAPI units from the threshold (D1) can be calculated from the equation:

$D1 = TCH \times \cotan$ (angle of lowest on-course signal) where the TCH is the threshold crossing height for the most demanding aircraft using the runway. Refer to [Table 7](#). The angle of the lowest on-course signal is determined as follows:

- For the L-880 PAPI system the angle of the lowest on-course signal will be the aiming angle of the third light unit from the runway minus 1.5 minutes of arc.



Note

The subtraction of 1.5 minutes of arc takes into account the width of the transition sector (3 minutes of arc) between the white and red part of the PAPI light beam. The lowest possible on-course signal is $3/2 = 1.5'$ lower than the aiming angle.

- For the L-881 PAPI system this angle will be the aiming angle of the outside light unit minus 1.5 minutes of arc.

4.5.4 Obstacle Clearance Surface

Position and aim the PAPI so that no risk exists of an obstruction being located in an area where the PAPI signals can be observed. Make a survey of the site to determine if an obstruction is present in the area where you can observe the PAPI signals.

See [Figure 3](#). This obstacle clearance surface begins 300 feet (91.44 m) in front of the PAPI units (closer to the threshold) and proceeds outward into the approach area at an angle of 1 degree less than the lowest on-course signal. This surface extends 10 degrees on either side of the runway centerline to a distance of 4 miles (6.44 km) from the point of origin.

If an obstruction penetrates the obstacle clearance surface and cannot be removed, then re-aim the glideslope angle or move the PAPI system further from the threshold. By moving or re-aiming the PAPI, re-position the obstacle clearance surface so that it will not be penetrated by an obstruction. See [Figure 11](#).

Figure 11: Obstacle Clearance Surface

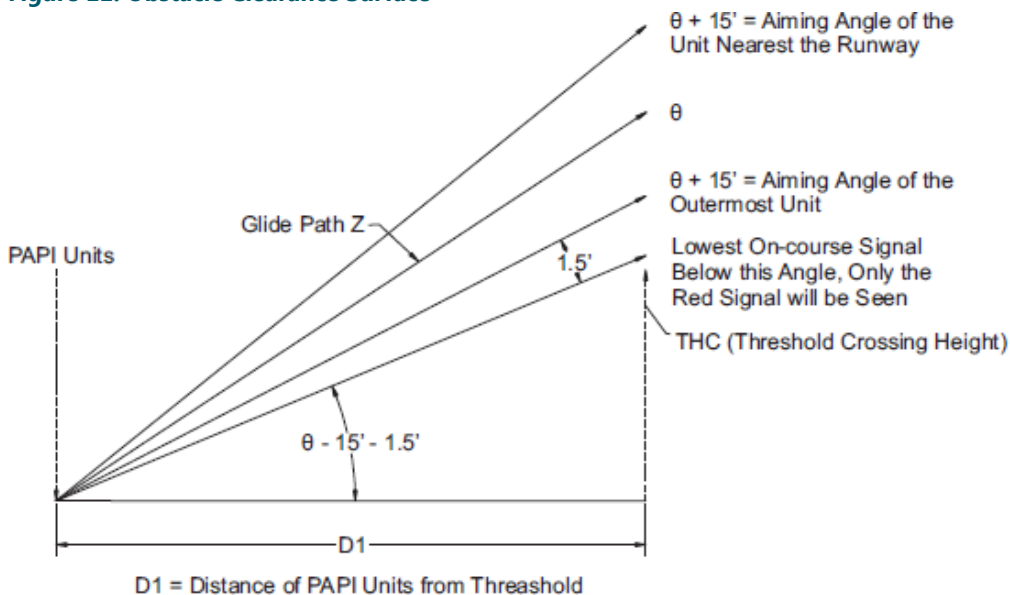

The 1.5' is one-half the width of the transition sector of the light beam. The transition between the white to red part of the beam is 3 minutes of arc (3'). Hence the additional 1.5' must be taken into account in calculating D1.

For L-881: $D1 = TCH \times \cotan (\theta - 15' - 1.5')$



Note

For the L-880 PAPI system, the lowest on-course signal will be the aiming angle of the third light unit from the runway minus 1.5'. For a standard L-880 installation the lowest on-course signal will be $\theta - 10' - 1.5'$. For Height Group 4 aircraft this angle will be $\theta - 15' - 1.5'$.

For L-880 (Standard Installation): $D1 = TCH \times \cotan (\theta - 10' - 1.5')$

For L-880 (Ht. Group 4 aircraft): $D1 = TCH \times \cotan (\theta - 15' - 1.5')$

4.5.5 Reduction of Beam Coverage for Obstacle Avoidance

A PAPI system may require a reduction of the horizontal beam coverage because of an obstacle in the approach area. If this is the case, special consideration should be given to the following factors when determining the required system cutoff angle(s):

- Type and location of the obstacle with respect to the area where the PAPI signals can be observed
- Wingspan of aircraft using the runway
- Vertical pitch of the glideslope
- Installation tolerances
- Position of the PAPI system
- Additional safety considerations
- Manufacturing tolerances are +0.0° to -0.4°
- Origin of the cutoff angle should be either the outermost or innermost unit (whichever is closest in azimuth to the obstacle)

When ordering a PAPI system with a reduced horizontal beam coverage from ADB SAFEGATE, the following information is required:

- Number of systems required
- Type of system -- L-880 or L-881; Style A or Style B
- Required cutoff angle (from pilot's viewpoint and tolerance)



Note

For example, if the nominal required cutoff is 7°, the cutoff angle which would be ordered is 7.2° (+0.0°, -0.4°). The additional 0.2° is added to the nominal value because it is the midpoint of the manufacturing tolerance (+0.0°, -0.4°). The sales order would say, for example, cutoff = 7° Right (from pilot's viewpoint).

- Left/right cutoff (from pilot's viewpoint when landing)

4.6 Siting Tolerances

Siting tolerances involve azimuthal aiming, mounting height tolerance, PAPI tolerance along a line perpendicular to the runway, and correction for the runway longitudinal gradient.

4.6.1 Azimuthal Aiming

Each light unit shall be aimed outward into the approach zone on a line parallel to the runway centerline within a tolerance of $\pm 1/2^\circ$.

4.6.2 Mounting Height Tolerance

The beam centers of all light units shall be within ± 1 inch (25.4 mm) of a horizontal plane. This plane shall be within ± 1 foot (304.8 mm) of the elevation of the runway centerline at the intercept point of the visual approach angle with the runway except for additional siting considerations. Refer to *Additonal Siting Considerations* in this section.

4.6.3 PAPI Tolerance Along Line Perpendicular to Runway

The front face of each light unit in a bar shall be located on a line perpendicular to the runway centerline within ± 6 inches (152.4 mm).

4.6.4 Correction for Runway Longitudinal Gradient

See Figure 12. Refer to AC 150/5435-28. On runways where a difference exists in elevation between the runway threshold and the elevation of the runway centerline adjacent to the PAPI, you may need to adjust the location of the light units with respect to the threshold to meet the required obstacle clearance and TCH.

Figure 12: Correction for Runway Longitudinal Gradient

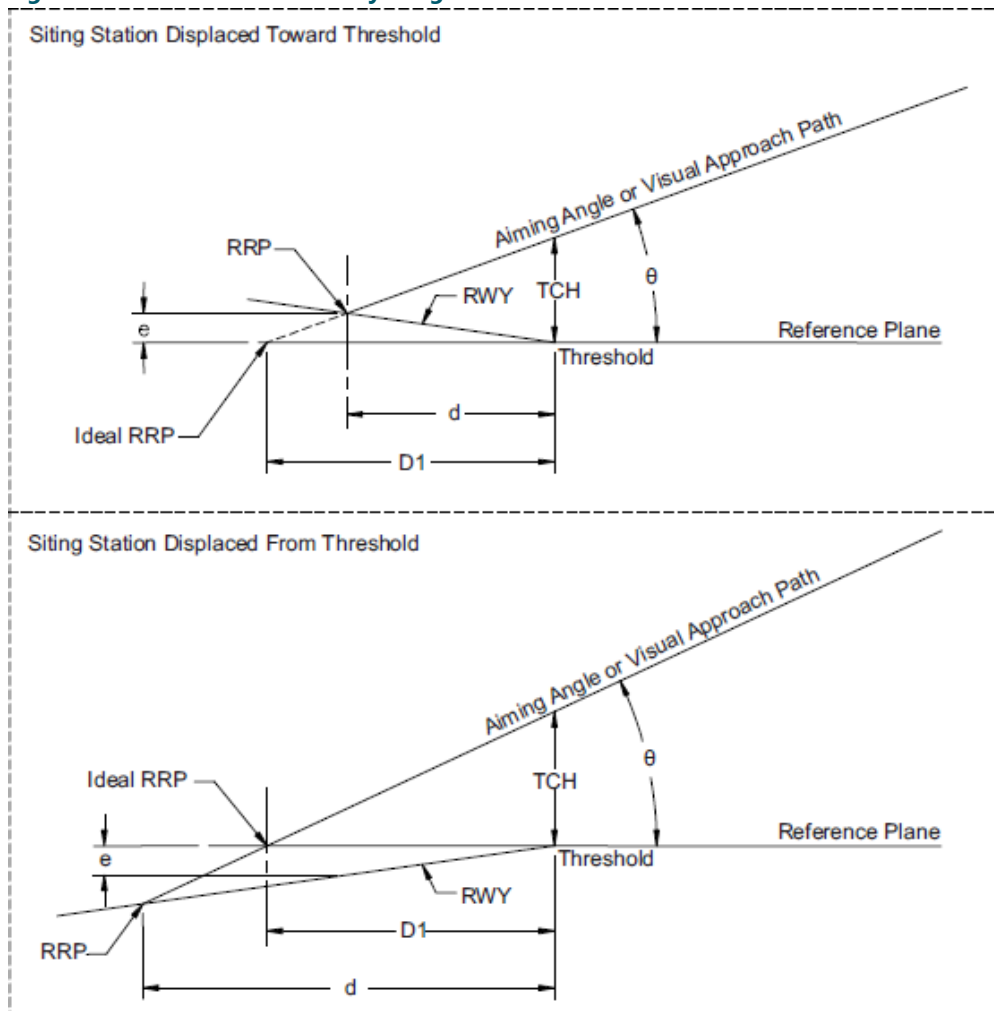

Symbols:

RWY = Runway Longitudinal Gradient
 TCH = Threshold Crossing Height
 RRP = Runway Reference Point (where Aiming Angle or Visual Approach Path intersects the Runway Profile)

D1 = Ideal (zero gradient distance of the PAPI Units from the Threshold)
 d = Adjusted Distance of the PAPI Units from the Threshold
 e = Elevation Difference Between the Threshold and the Runway Reference Point
 θ = Aiming Angle

If the condition exists, perform the following steps to compute the change in the distance from the threshold required to preserve the proper geometry:

1. Obtain the runway longitudinal gradient. This can be done by survey or obtained from airport obstruction charts or as-built drawings.
2. Determine the ideal (zero gradient) distance from the threshold in accordance with the preceding instructions.
3. Assume a level reference plane at the runway threshold elevation. Plot the location determined in Step 2 above.
4. Plot the runway longitudinal gradient.

5. Project the visual glideslope angle to its intersection with the runway longitudinal gradient. Then solve for the adjusted distance from the threshold either mathematically or graphically. Refer to *Mounting Height Tolerance* in this section.
6. Verify the calculated location gives the desired threshold crossing height.

4.7 Additional Siting Considerations

Below are additional siting considerations.

- Where the terrain drops off rapidly near the approach threshold and severe turbulence is experienced, locate the PAPI farther from the threshold to keep the aircraft at the maximum possible threshold crossing height.
- On short runways, the PAPI should be as near the threshold as possible to provide the maximum amount of runway for braking after landing.
- See [Figure 13](#). At locations where snow is likely to obscure the light beams, install the light units up to a maximum height of 6 feet (1.83 m) above ground level. This may require installing the light units farther from the runway edge to ensure adequate clearance for the most critical aircraft.

Since increasing the height of the light units also increases the threshold crossing height of the visual glideslope, you may need to relocate the lights closer to the threshold to remain within the specified tolerance.

- Since the effectiveness of the PAPI system is dependent on the optical red and/or white signal pattern from the light units, make sure that no other lights are close enough to confuse the pilot.

Figure 13: Relocating PAPI Units

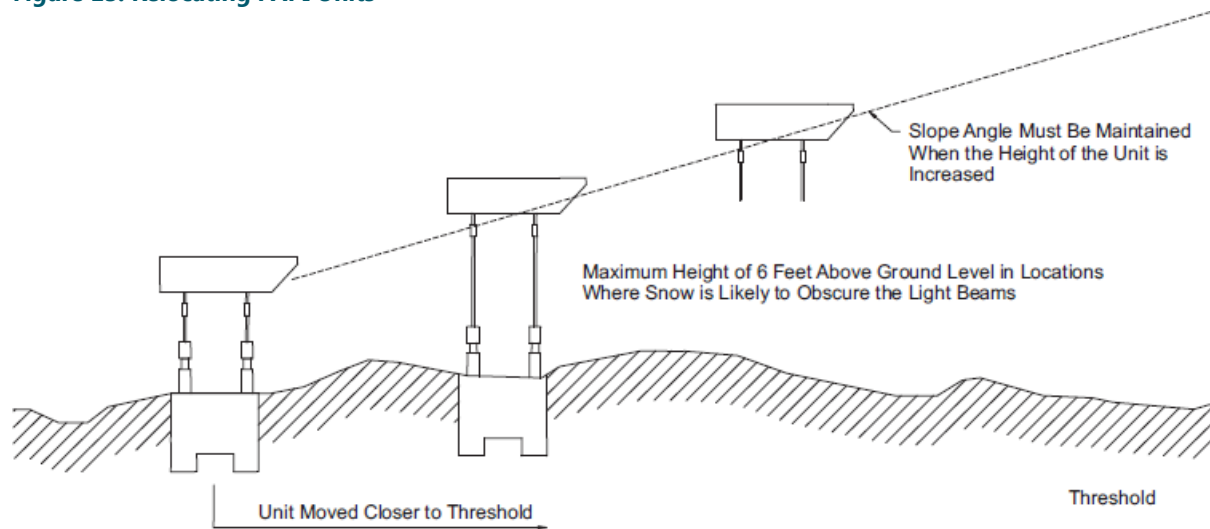

4.8 PAPI Foundations

The PAPI units shall be installed on concrete pads at ground level with frangible couplings. The foundation should extend at least 12 inches (304.8 mm) below the frost line and at least 1 foot (304.8 mm) beyond the light unit to minimize damage from mowers. Figure 14 through Figure 17 show dimensions that are generally acceptable for the concrete pad for the two-lamp and three-lamp PAPI respectively.

Figure 14: Installation on Concrete Pad (Two-Lamp, Three-Leg PAPI)

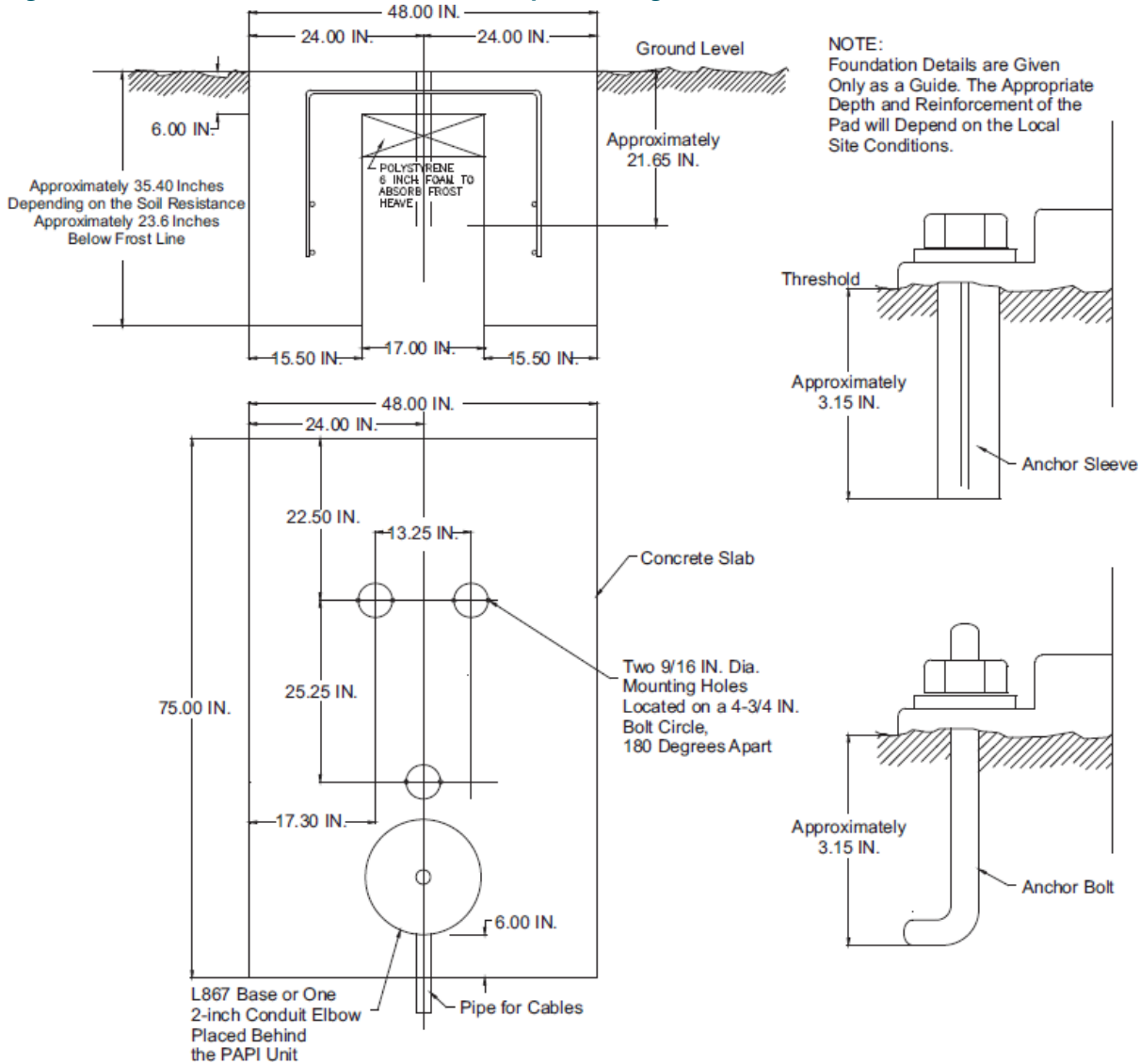

Figure 15: Installation on Concrete Pad (Two-Lamp, Four-Leg PAPI)

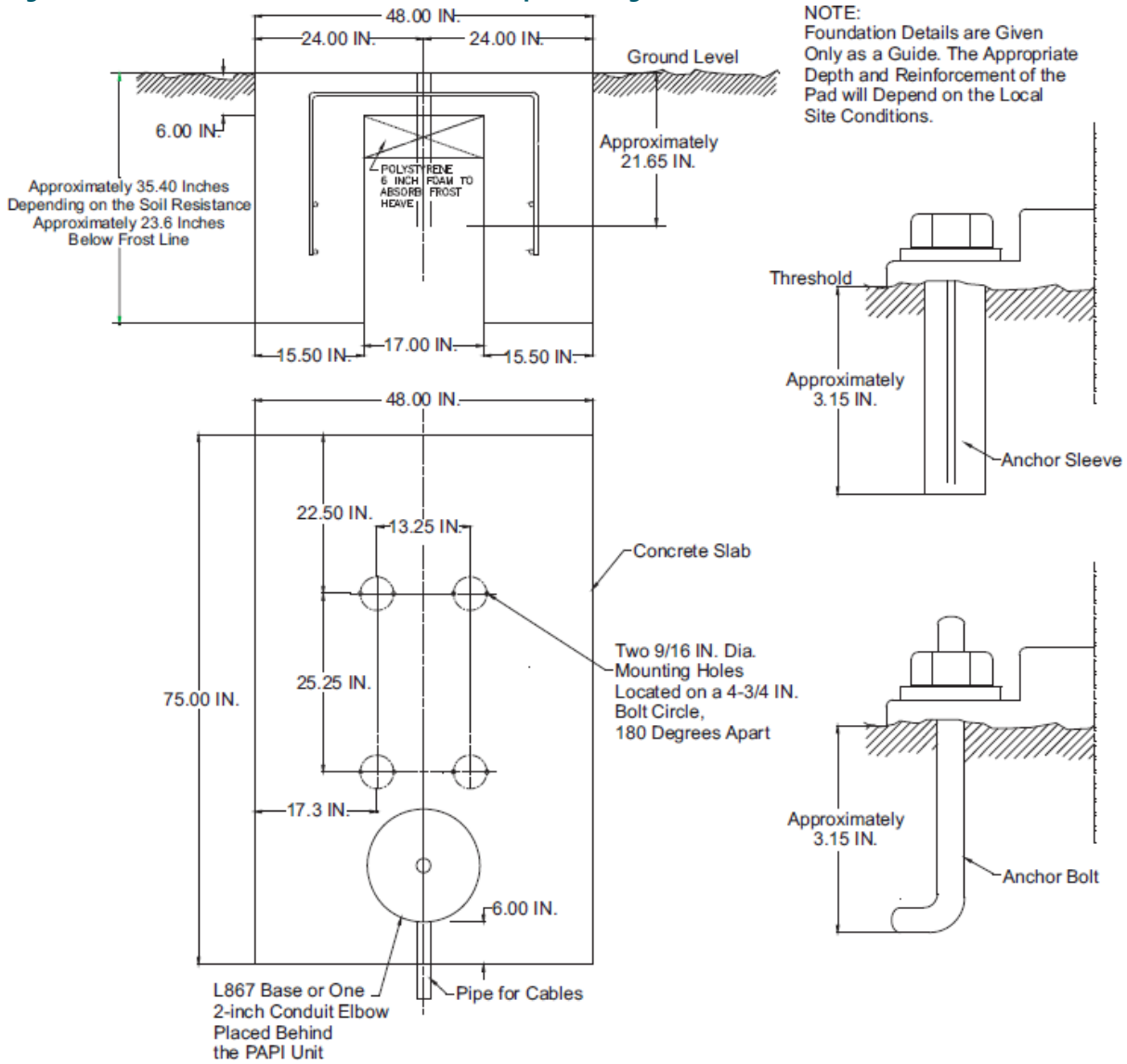

Figure 16: Installation on Concrete Pad (Three-Lamp, Three-Leg PAPI)

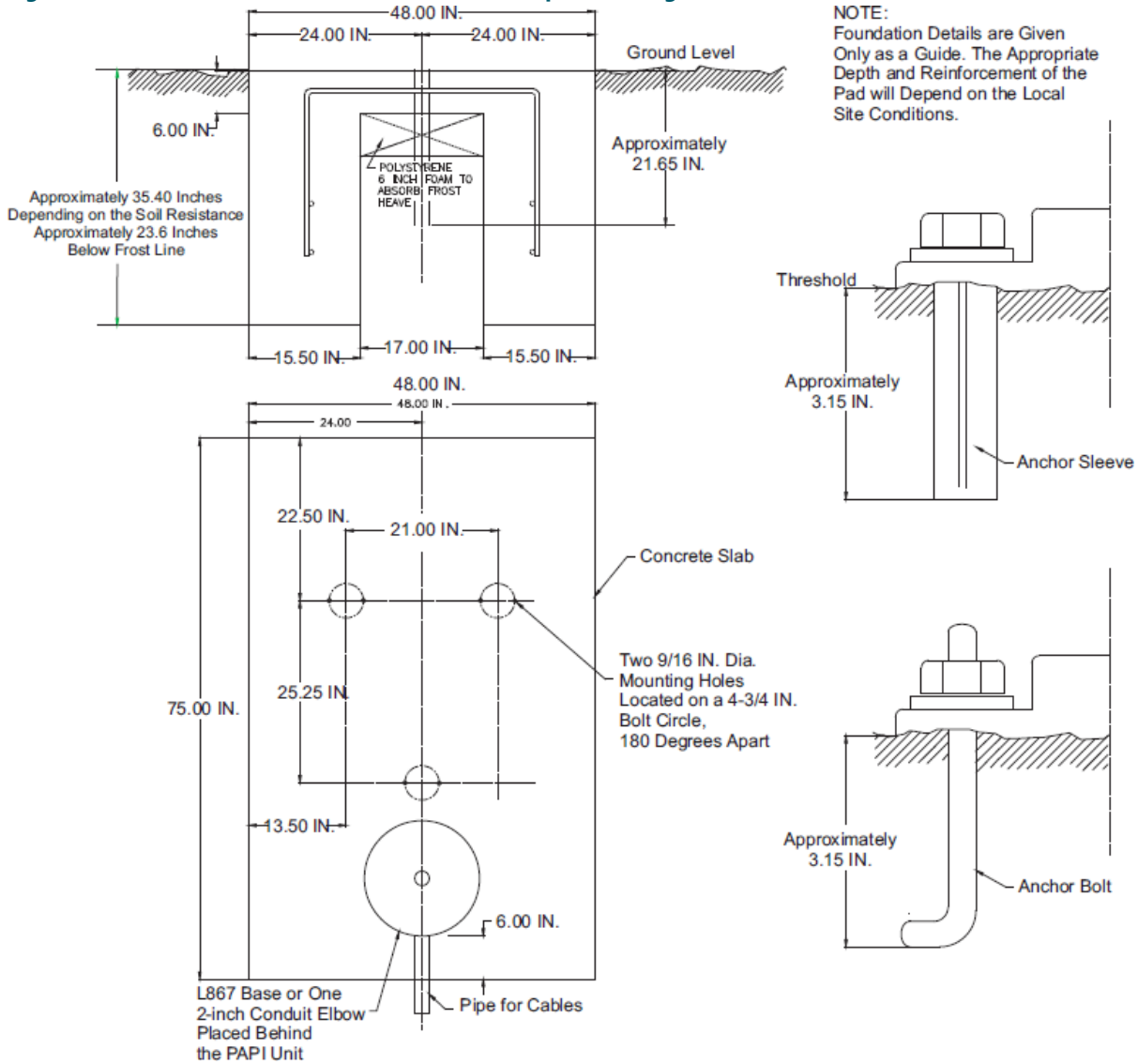
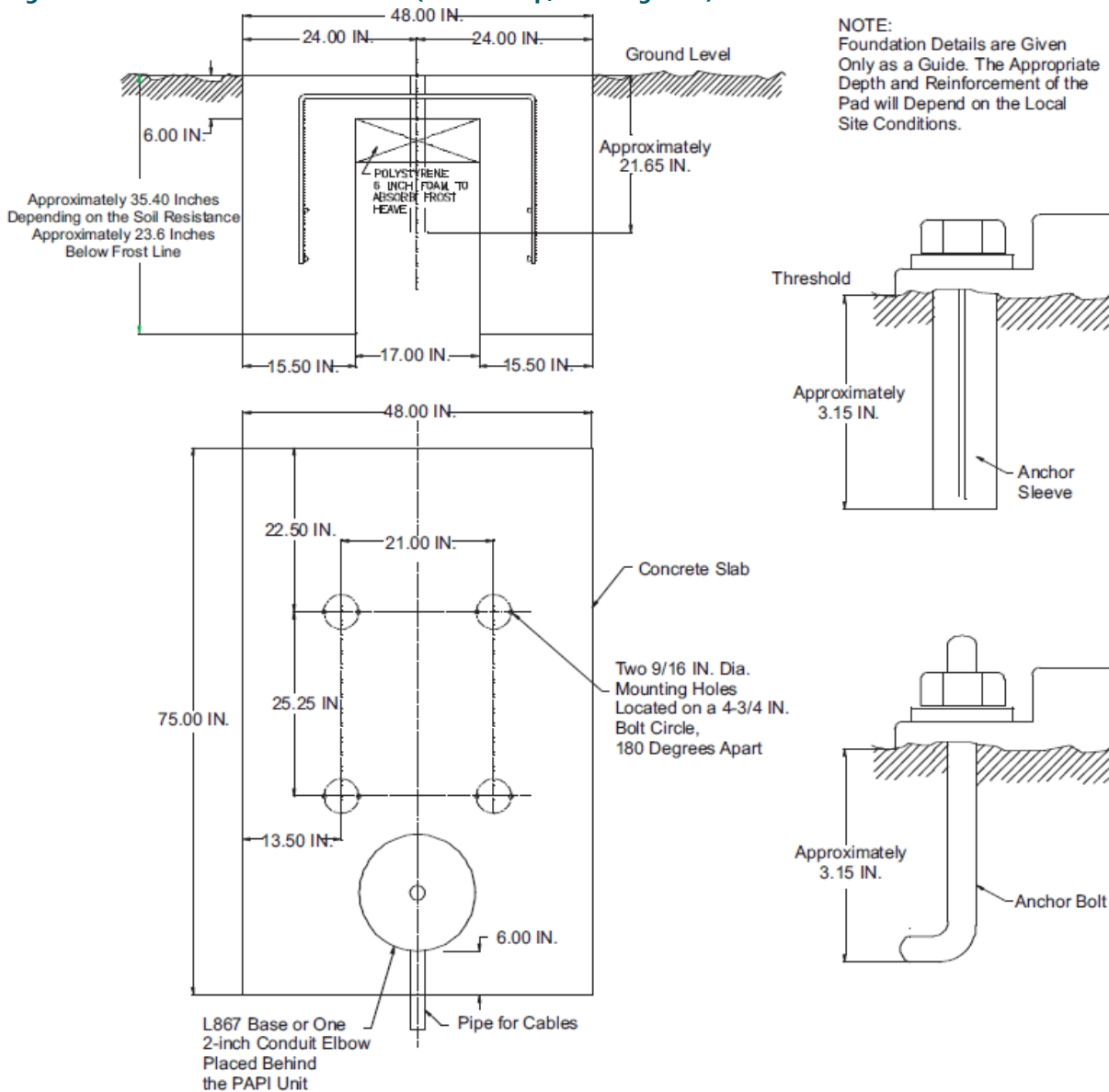

Figure 17: Installation on Concrete Pad (Three-Lamp, Four-Leg PAPI)



To cast the concrete pad and anchor the support fixtures, perform the following procedure:

1. Stake out the longitudinal axis of the light units parallel to the runway centerline.
2. Dig the foundation hole per [Figure 14](#) and [Figure 15](#) for the two-lamp and [Figure 16](#) and [Figure 17](#) for the three-lamp.
3. Place foam in pit to absorb frost heave below the central part of the slab. Place L-867 light base/conduit elbows or pipes for cables. Place bars for reinforcement of concrete.
4. Pour in concrete and allow it to harden for at least one day.
5. After concrete sets up, using chalk draw a longitudinal axis (in accordance with the axis staked out on the ground) on the upper surface of the pad. Draw a transverse axis perpendicular to the other axis.
6. See [Figure 18](#) and [Figure 19](#) for the two-lamp/three- and four-leg and [Figures 3-15](#) and [3-16](#) for the three-lamp/three- and four-leg PAPI. Lay a positioning plate on the pad; center it by positioning the central hole at the intersection of both axes; align the plate along the longitudinal axis using the V-notches in the plate.
7. Mark the eight locations of the screws on the slab; drill the eight holes to the diameter and depth required for the expansion sleeves and insert the sleeves.
8. See [Figure 18](#) through [Figure 21](#) to locate flanges using mounting templates. Place and fasten the flanges with two screws.

Figure 18: Positioning Plate (Two Lamps/Three Legs)

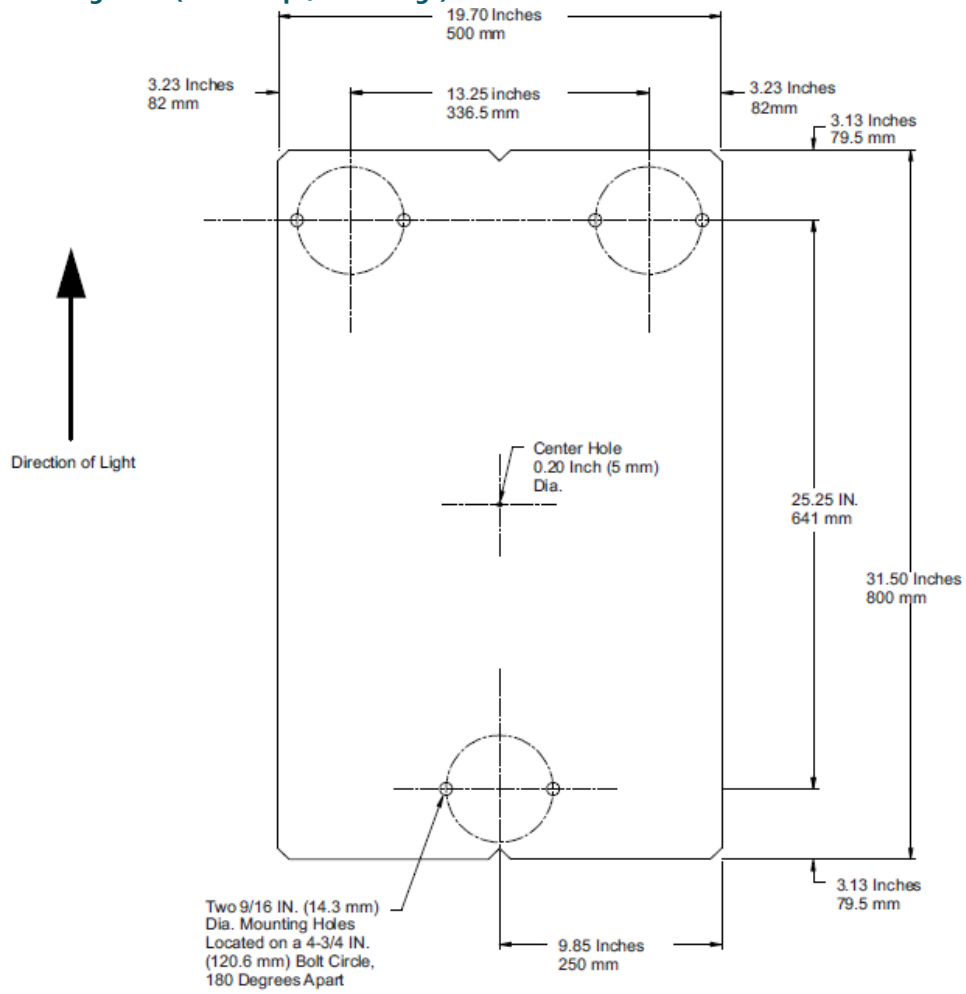

Figure 19: Positioning Plate (Two Lamps/Four Legs)

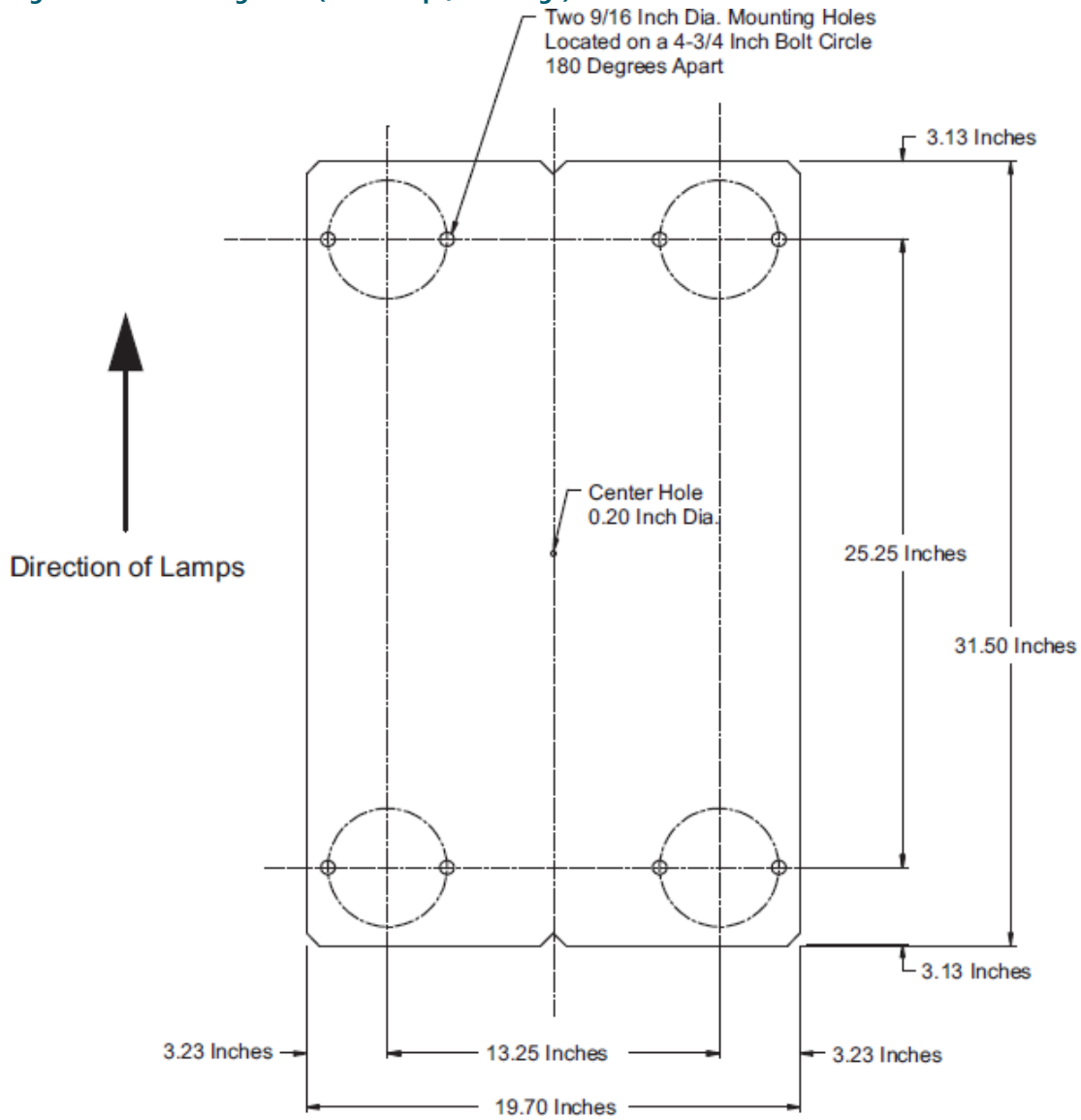

Figure 20: Positioning Plate (Three Lamps/Three Legs)

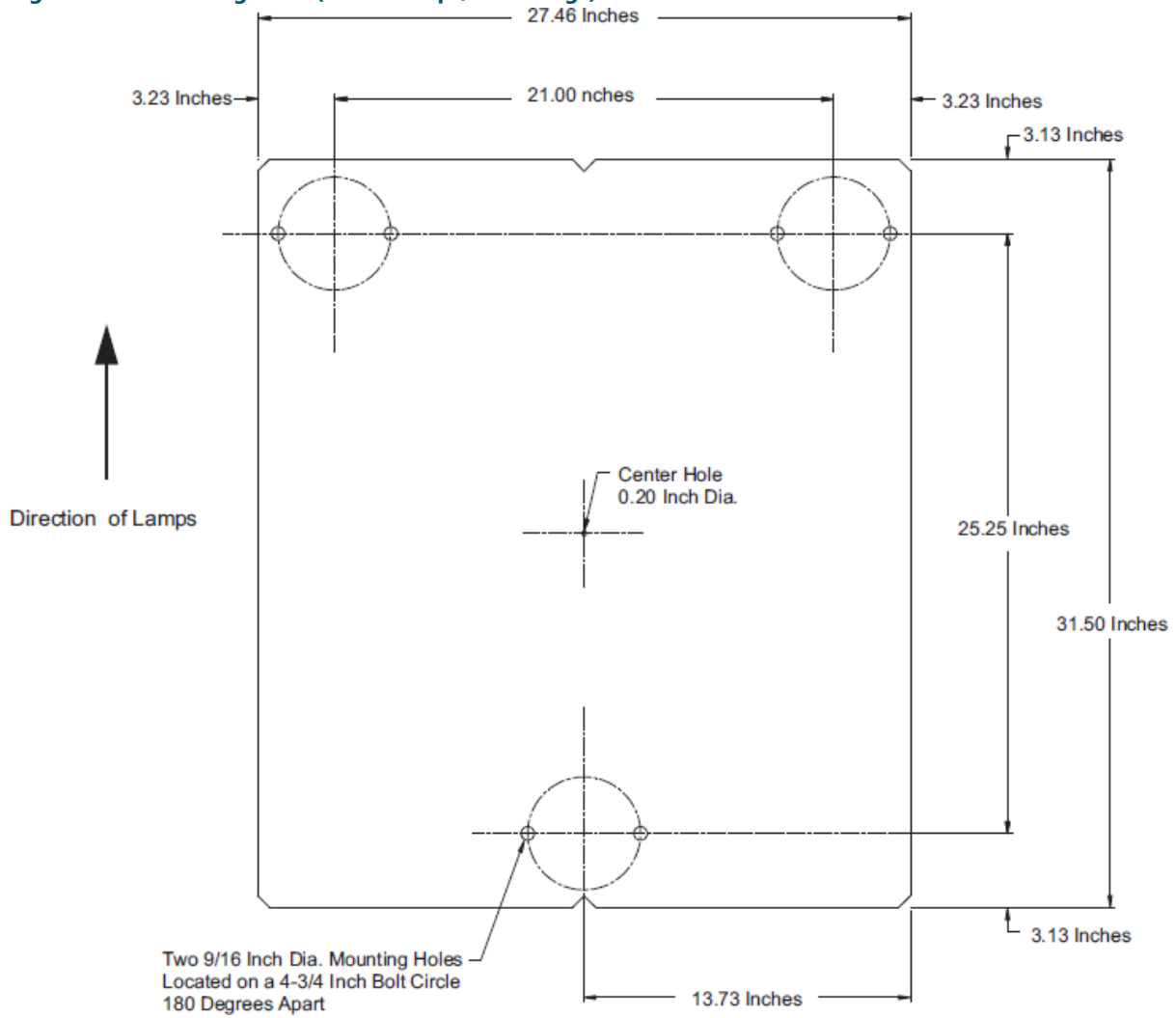
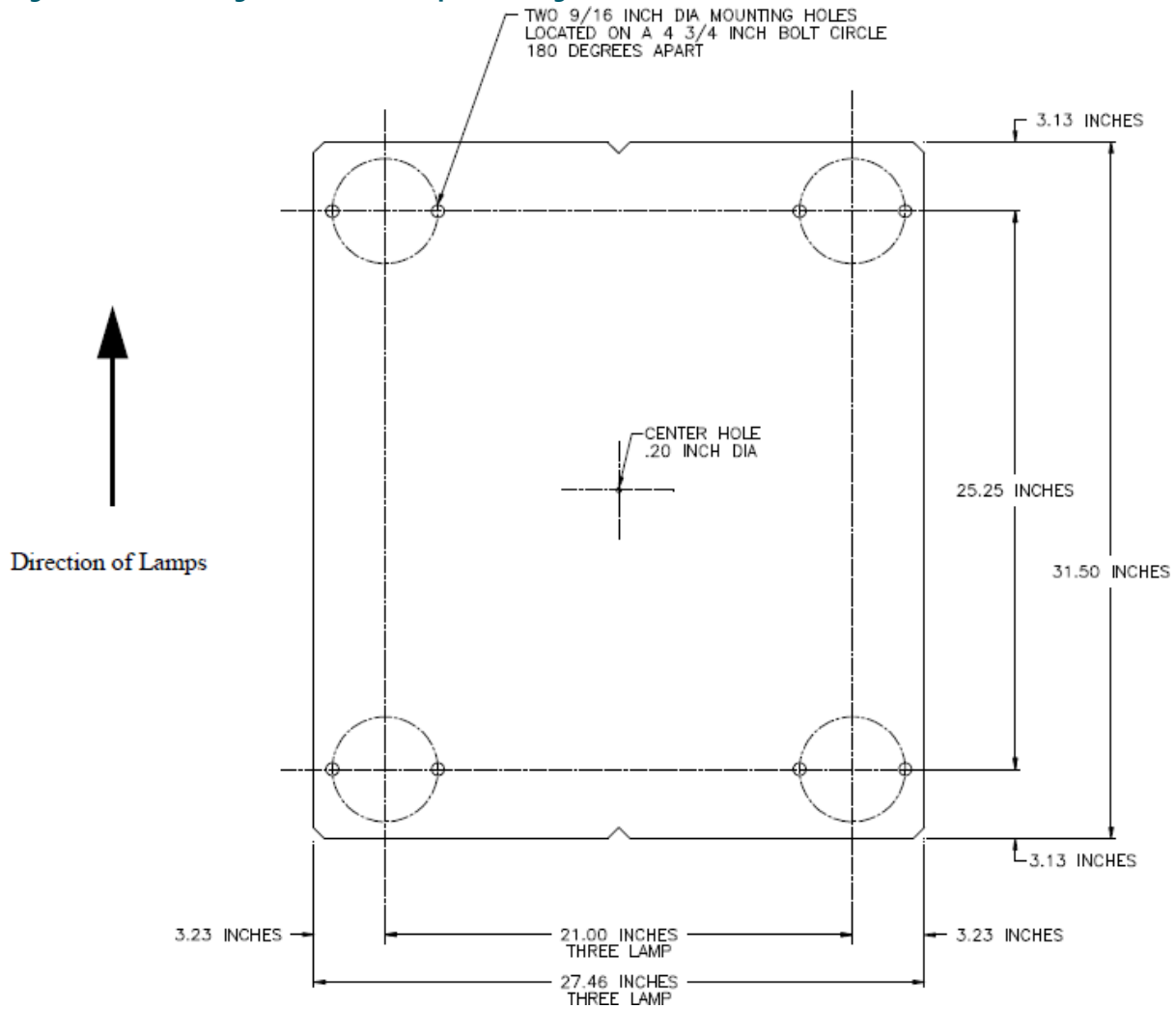

Figure 21: Positioning Plate (Three Lamps/Four Legs)



- Install the frangible couplings. Make sure to place the second nut, ferrule compression joint, and ferrule ring on the bottom of the EMT tube first before screwing the tube with nuts, joints, and rings onto the frangible coupling. See [Figure 22](#).

Note

The contractor supplies and installs the 2-inch (50.8 mm) diameter (2-3/16 OD) EMT tube. Determine length at installation to adjust for uneven elevation above the runway. The 2-inch EMT tube extends into the frangible coupling 3.25 inches (82.55 mm) and 1-1/2 inches (38.1 mm) into the nut and ferrule compression joint to ensure stable installation. Paint the tube according to Federal standard 595A, color #12197, international orange, to reduce corrosion.



Note

Instead of expansion sleeves, cast 3/8-16 x 6-inch anchor j-bolts into the concrete at the proper locations on a 4 3/4 in. (120.65 mm) diameter bolt circle, in two places.

Figure 22: Frangible Coupling

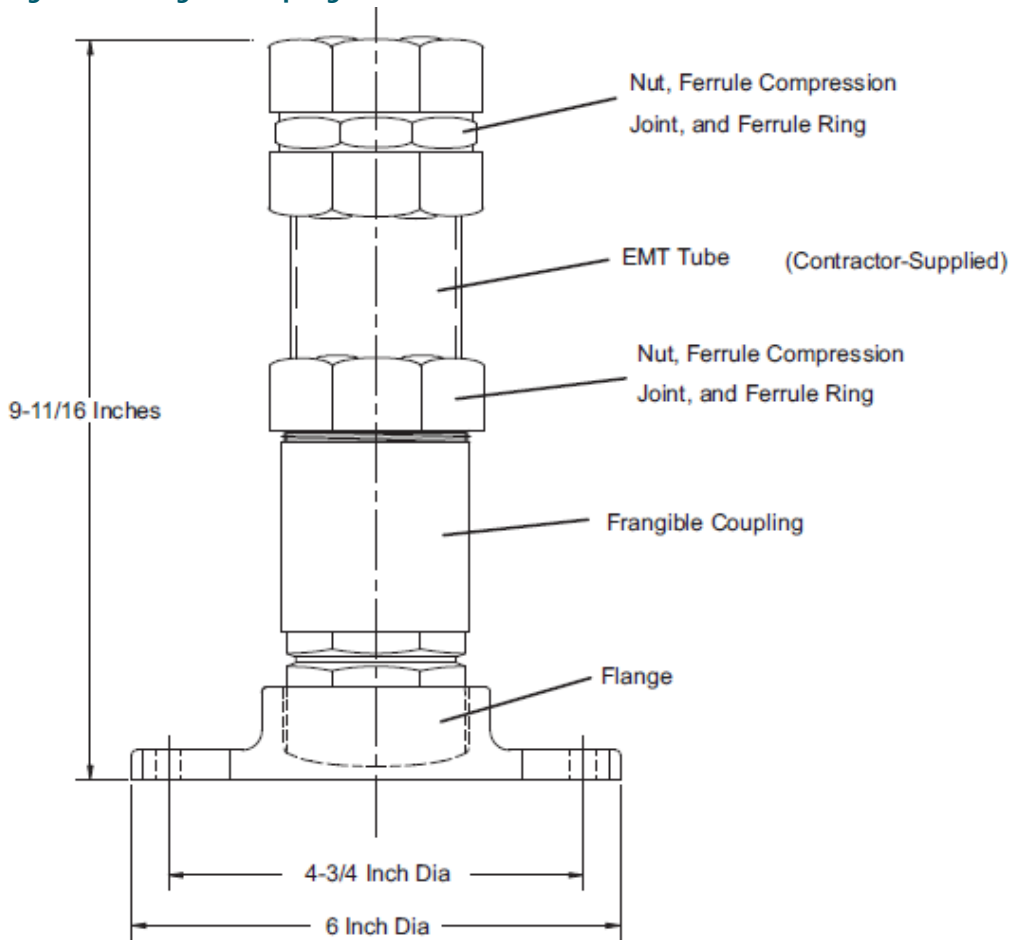

4.9 PAPI Aiming Angles

Refer to [Table 8](#) and [Table 9](#) for the aiming angles for the L-880 and L-881 PAPI light units.

Table 8: Aiming Angles for L-880 PAPI Units

L-880 (4 box) PAPI	Aiming Angle (Minutes of Arc) (Standard Installation)	Aiming Angle (Minutes of Arc) (Height Group 4 Aircraft* on Runway with ILS)	Note
Unit nearest runway	30' above glide path	35' above glide path	A
Next adjacent unit	10' above glide path	15' above glide path	A
Next adjacent unit	10' below glide path	15' below glide path	A
Next adjacent unit	30' below glide path	35' below glide path	A

NOTE: A: Refer to Table for *Siting PAPI with ILS Glideslope*.

Table 9: Aiming Angles for L-881 PAPI Units

L-881 (2 box) PAPI	Aiming Angle (Minutes of Arc) (Standard Installation)
Unit nearest runway	15' above glide path
Unit farthest from runway	15' below glide path

i Note
60 minutes of arc = one degree (60' = 1°)

4.10 Assembling Adjustable Legs

Assemble the legs for each PAPI unit as follows:

1. See [Figure 7](#) . Screw threaded rods (5) into differentials (7) and assemble legs.

i Note
Do not assemble upper hex nut (1), upper split lock washer (2) , and upper flat washer (13). These items will be installed after the PAPI unit is mounted on the legs.

2. Screw front and rear leg assemblies into the frangible couplings installed on concrete pad.

4.11 Mounting Unit

To mount the unit, perform the following procedure:

1. See [Figure 7](#) . Gently mount PAPI unit on the three or four legs so that the unit rests on the top of the lower flat washer (12), lock washer(3), and hex nut(4).

i Note
For the three-leg PAPI, assemble the upper end of the center rear leg as shown in [Figure 7](#) . Make further adjustment of the leg height by using the PAPI differential(7).

i Note
See also [Figure 23](#) and [Figure 24](#) while mounting unit. [Figure 23](#) shows the two-lamp, four-leg PAPI. [Figure 24](#) shows the two-lamp, three-leg PAPI. [Figure 23](#) and [Figure 24](#) also apply to the three-lamp PAPI.

Figure 23: Elevation Setting Sequence (Two-Lamp, Four-Leg PAPI Shown)

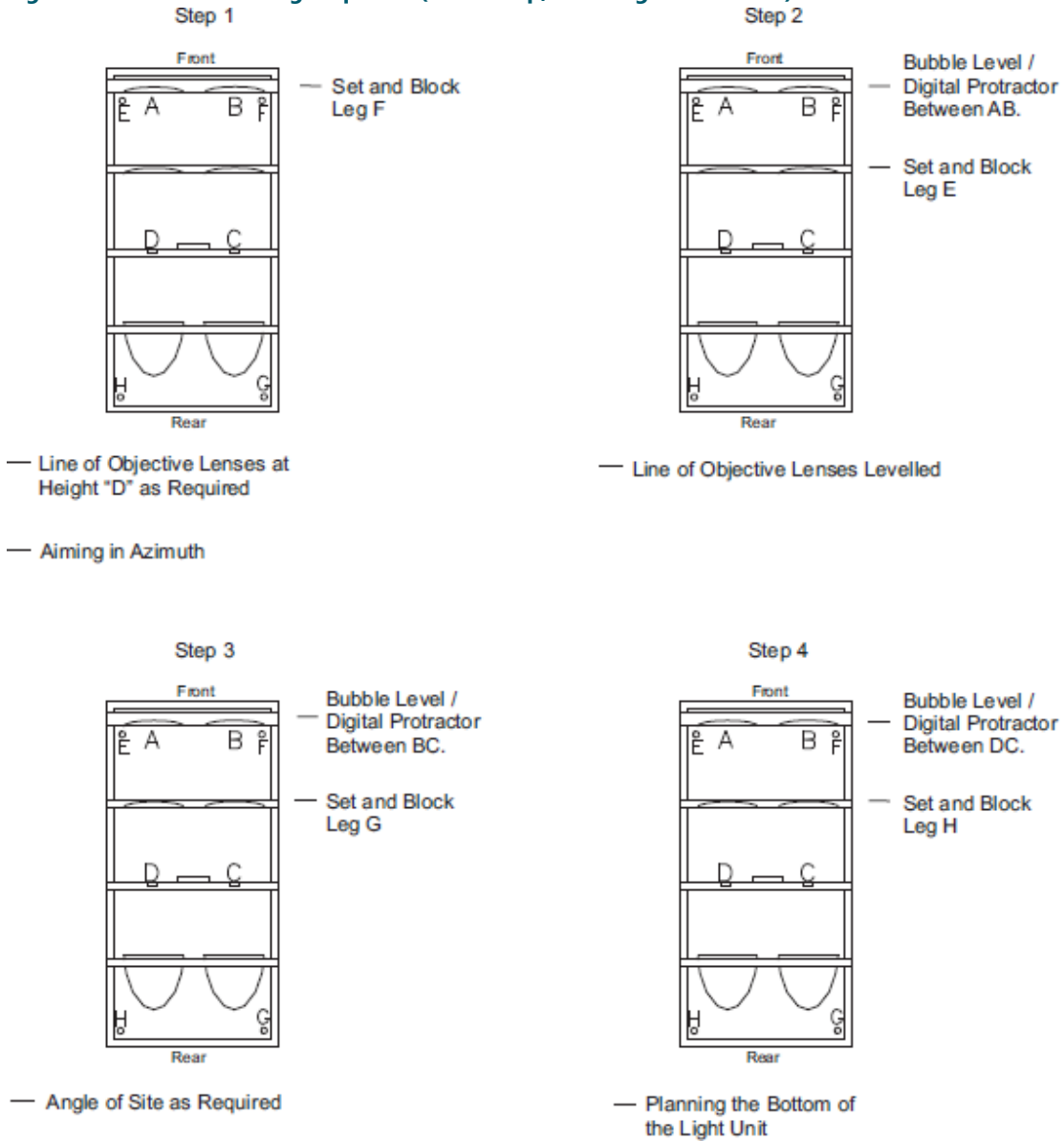
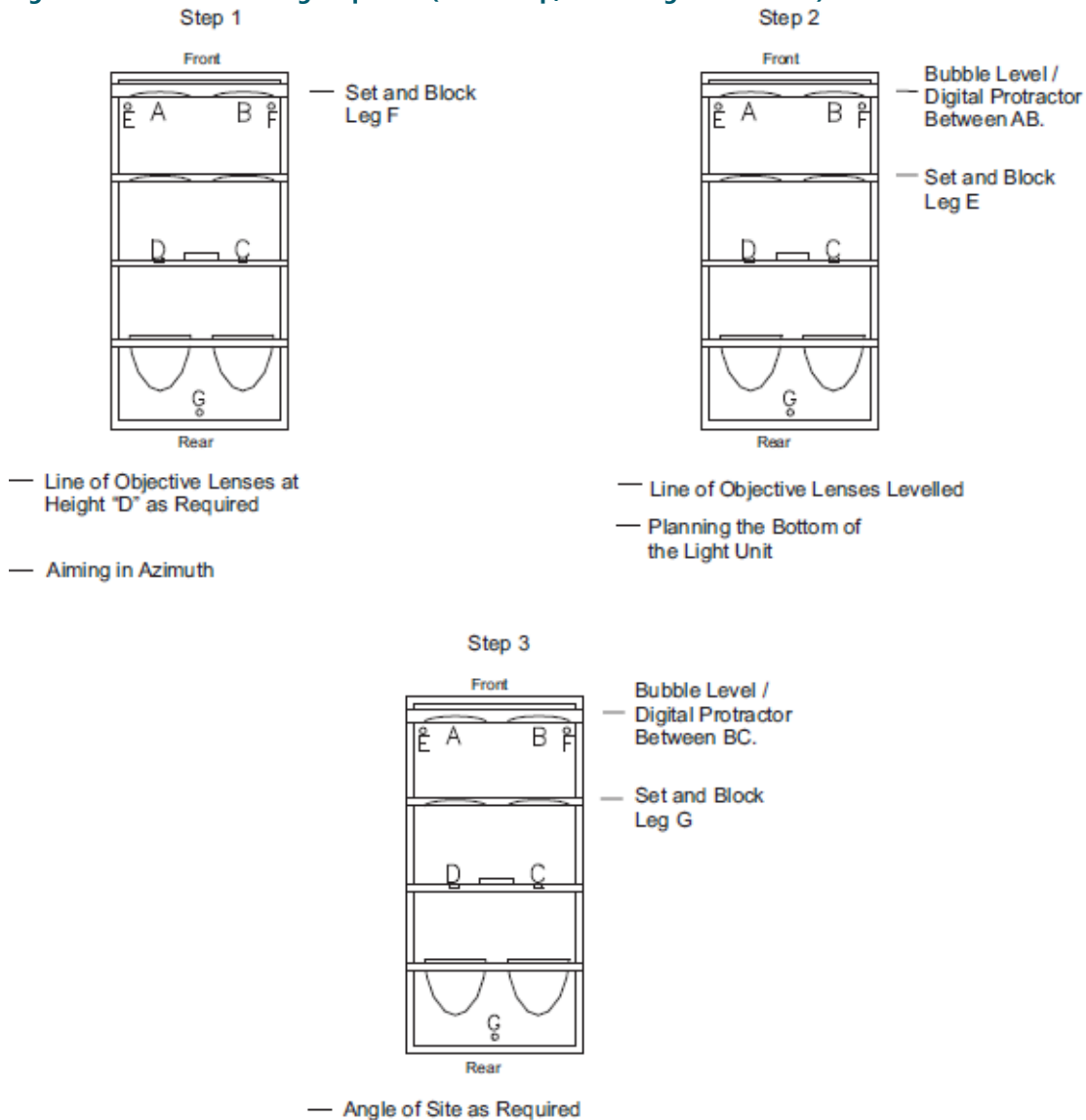

Figure 24: Elevation Setting Sequence (Two-Lamp, Three-Leg PAPI Shown)



2. Install the upper flat washer(13), lock washer(2), and hex nut(1) on the threaded rod.
Do not tighten nuts.
3. Make sure the bottom of the unit is resting on the top of the lower flat washer(12) of the right front leg F.
4. Make sure all locking nuts on the frangible couplings are tightened.

4.12 Aligning Units

This subsection provides information for aligning the PAPI units using the two types of aiming devices: the bubble-level style and the digital-level style. Aligning the PAPI involves knowing how the two types of aiming devices work, using bubble-level or digital-level aiming device to align PAPI, and leveling the tilt switch.



Note

Alignment procedures are shown for the 2-lamp PAPI in [Figure 23](#) and [Figure 24](#) , but the procedures apply to the 3-lamp PAPI as well.

4.12.1 How Bubble-Level Aiming Device Works

See [Installation Using Bubble-Level Style Aiming Device](#) . The bubble-level aiming device has two graduated scales, a large metallic scale and a plastic scale (on the upper arm of the aiming device) which are used to set the aiming angle.

The **metallic scale** is calibrated in **10 minutes of arc** from 0° to 10°. Since there are 60 minutes of arc in one degree (60' = 1° or 30' = 1/2°), there are 6 divisions (0-10', 10-20', 20-30', 30-40', 40-50', 50-60') between each degree tic mark on the scale. Note the 30 minute or 1/2 degree tic mark between each degree tic mark (0 to 1°, 1 to 2°, 9 to 10°) on the metallic scale is slightly longer than the 10', 20' or 40' and 50' tic marks.

The **plastic scale** is calibrated in **minutes of arc** from 0 to 10 minutes. If an angular setting of, for example, 3° 30' is desired, the setting on the aiming device is obtained by moving the upper bar of the aiming device with the attached plastic graduate scale so that the *0 line on the plastic scale lines up exactly with the 3° 30' tic mark on the metallic scale* (the 30 minute (30') tic mark is midway between the 3 degree and 4 degree tic marks). After obtaining this setting, tighten the locking screw on the upper arm to secure the angular setting.

Suppose now that an angle of 3° 35' is desired. To obtain this setting, perform the following procedure:

1. Set the 0 line on the plastic scale at the 3° 30' tic mark as described above.
2. Locate the 5 minute line on the plastic scale. It will not be lined up with any of the tic marks on the metallic scale.
3. To obtain the desired setting of 3° 35', slowly move the 5 minute line upward until it lines up exactly with the **next tic mark** on the metallic scale. The 5 minute line on the plastic scale will be exactly lined up with the 4° 20' tic mark on the metallic scale when the aiming device is set for 3° 35'.



Note

The 0° line on the bottom of the plastic scale will be centered between 3° 30' tic mark and 3° 40' tic mark on the metallic scale. Tighten the locking screw on the upper arm to secure the arm's angular setting.

4. Practice using the aiming device to obtain the following angular settings: 3° 33' and 3° 38'.



Note

The 3° 33' angular setting is obtained when the 3 minute line on the plastic scale is lined up with the 4 degree tic mark on the metallic scale; the 3° 38' angular setting is obtained when the 8 minute line on the plastic scale is lined up with the 4° 50' tic mark on the metallic scale.

4.12.2 How Digital-Level Aiming Device Works

This subsection describes how the digital-level aiming device works. It provides information about the digital aiming device, how to calibrate the digital protractor, and how to install the digital protractor battery.



CAUTION

Digital-Level device protractor must be calibrated before each use to insure accuracy. See page 3-33 for calibration instructions.

4.13 Digital Aiming Device

See [Figure 9](#) and [Figure 10](#) . The digital-level aiming device has one survey device with two pivoting arms and a precision digital protractor that reads in 0.01 degree increments. Each 0.01 degree increment indicates a 0.6 minute movement.

The digital level reads directly in degrees with one hundredth (.XX) of a degree resolution. [Table 10](#) is provided to convert minutes to decimal of degrees.

Example:

3° 35' would read 3.58°.

3° 15' would read 3.25°.

Suppose now that an angle of 3° 33' is desired. To obtain this setting, perform the following procedure:

1. Set the digital leveling device on mounting points A, B, C, and D per [Figure 23](#) or [Figure 24](#) .
2. Aim the PAPI A box per the procedure on [Figure 14](#) or [Figure 15](#) as applicable.



Note

The digital level displays the precise angle at which the PAPI is aimed. In this case, 3° 33' converts to 3.55°. A laminated card with the conversion chart is provided with each alignment device.

Table 10: Conversion from Decimal Degrees to Minutes

Minutes	Decimal Degrees	Minutes	Decimal Degrees
1	0.02	31	0.52
2	0.03	32	0.53
3	0.05	33	0.55
4	0.07	34	0.57
5	0.08	35	0.58
6	0.10	36	0.60
7	0.12	37	0.62
8	0.13	38	0.63
9	0.15	39	0.65
10	0.17	40	0.67
11	0.18	41	0.68
12	0.20	42	0.70
13	0.22	43	0.72
14	0.23	44	0.73
15	0.25	45	0.75
16	0.27	46	0.77
17	0.28	47	0.78
18	0.30	48	0.80
19	0.32	49	0.82
20	0.33	50	0.83
21	0.35	51	0.85
22	0.37	52	0.87
23	0.38	53	0.88
24	0.40	54	0.90
25	0.42	55	0.92
26	0.43	56	0.93
27	0.45	57	0.95

Table 10: Conversion from Decimal Degrees to Minutes (Continued)

Minutes	Decimal Degrees	Minutes	Decimal Degrees
28	0.47	58	0.97
29	0.48	59	0.98
30	0.50	60	1.00

4.13.1 Calibrating Digital Protractor

Calibrating the digital-level style aiming device involves performing an accuracy test and if necessary, a calibration test for the digital protractor.

 **Note** Refer to *Operating Digital Protractor* in the *Operation* section for digital protractor operating instructions.



CAUTION

To ensure accurate readings with the digital protractor, calibrate before each use. It is also recommended to calibrate the digital protractor if it has been dropped or if it is being used in an environment that varies more than 5 °C (9 °F) from the environment in which it was last calibrated. Refer below for calibration instructions.

4.13.2 Performing Digital Protractor Accuracy Test

To perform the accuracy test for the digital protractor, perform the following procedure:

1. See [Figure 25](#) . Position the digital protractor with the display facing you on a clean, flat horizontal surface. It doesn't have to be exactly level. Wait ten seconds so the unit is completely settled and note the angle on the display.

Figure 25: Positioning Digital Protractor

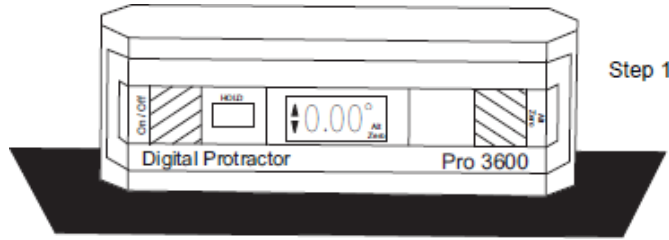

2. See [Figure 26](#) . Rotate the unit end-for-end so that the display is facing away from you. Be sure to set the digital protractor in exactly the same spot, and wait 10 seconds before reading the angle that is displayed.

Figure 26: Rotating and Rolling Protractor

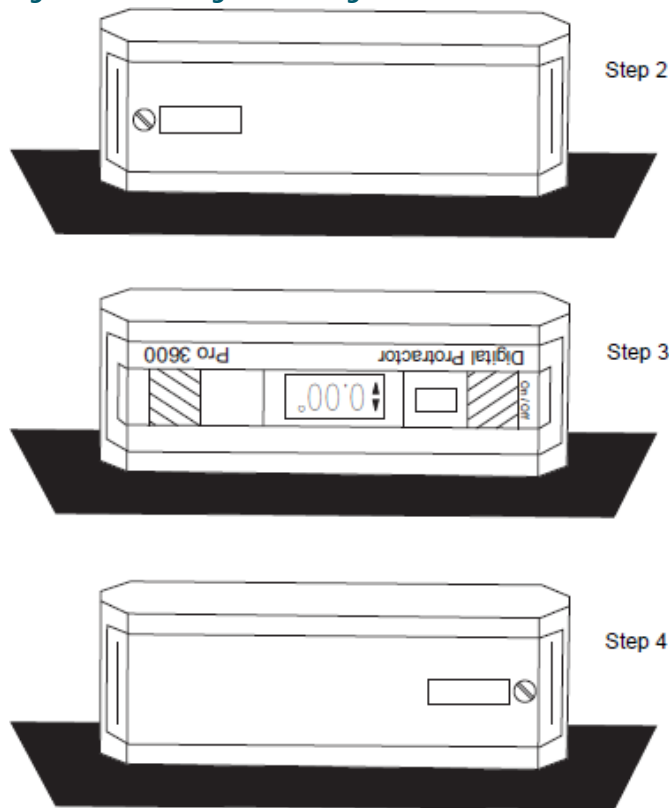

3. Now roll the unit forward so that that display is facing you, but the lettering on the face of the unit is upside down. Wait 10 seconds and note the angle on the display.
4. Rotate the unit end-for-end so that the display is facing away from you. The lettering should still be upside down. Wait 10 seconds and note the angle on the display.



CAUTION

If any of the four measurements in steps 1 through 4 varies from any other by more than 0.1 degrees, you must recalibrate the digital protractor. Refer below for calibration procedure.

4.13.3 Performing Digital Protractor Calibration Procedure

The calibration procedure below calibrates the digital protractor through its entire 360 degree range by electronically recording four horizontal and four vertical settings. It should be performed whenever the accuracy test shows a discrepancy of 0.1 degrees or more.

Note You may cancel the calibration procedure at any time by turning off the digital protractor.

To calibrate the digital protractor, perform the following procedure:

1. Turn on the digital protractor and place it on a flat surface. You can use any horizontal surface within 10 degrees of level and any vertical surface within 10 degrees of plumb. You must use the same surfaces throughout the entire process.

Note Each time you reposition the digital protractor, wait a minimum of 10 seconds before pressing the HOLD button to advance to the next step.

2. See Figure 27 . Press and hold the HOLD and ALT ZERO buttons simultaneously. Keep them depressed for approximately three seconds.

Figure 27: Digital Protractor Displays and Buttons

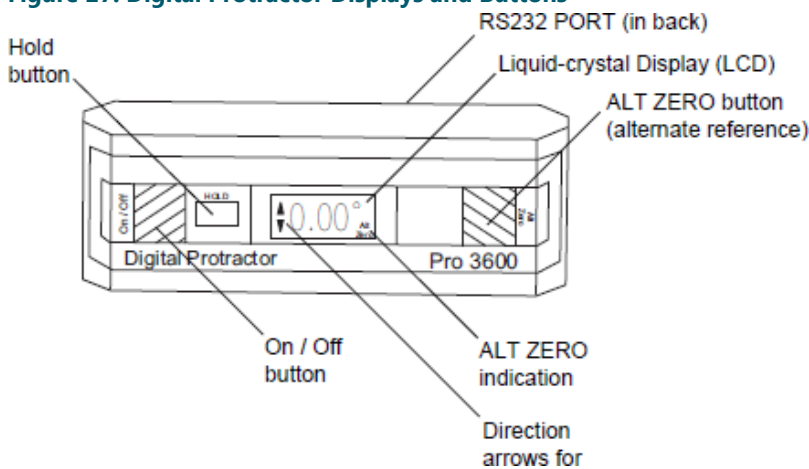

3. See Figure 28 . Release the buttons when the symbol "SUP" appears. A 0 within flashing brackets then appears. These brackets are composed of four horizontal and four vertical segments.

Note As you proceed through this procedure, a new segment will hold steady after you complete each step.

Figure 28: 0 within Flashing Brackets



4. Calibrate horizontal settings by performing the following procedure:

- a. See [Figure 29](#) . Face the digital protractor toward you. The white lettering on the face should be right-side up. Align with an edge or line. Wait 10 seconds. Press the HOLD button until **[1]** appears.

Figure 29: Rotating and Rolling Digital Protractor for Horizontal Settings

Step 4a

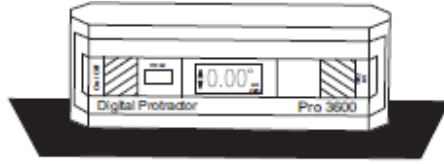

Step 4b



Step 4c

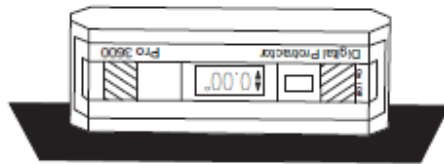

Step 4d



- b. Rotate the digital protractor so that it faces away from you. The lettering should still be right-side up. Align with the same edge or line. Wait 10 seconds. Press the HOLD button until **[2]** appears.

- c. Roll the protractor so that it faces you. The lettering should now be upside down. Align with the same edge or line. Wait 10 seconds. Press the HOLD button until **[3]** appears.
 - d. Rotate the protractor so that it faces away from you. The lettering should still be upside down. Align with the same edge or line. Wait 10 seconds. Press the HOLD button until **[4]** appears.
5. Calibrate vertical settings by performing the following procedure:
- a. See [Figure 30](#) . Place the digital protractor against a vertical surface so that it faces you. The lettering on the face should read from bottom to top. Align with an edge or line. Wait 10 seconds. Press the HOLD button until **[5]** appears.

Figure 30: Rotating and Rolling Digital Protractor for Vertical Settings

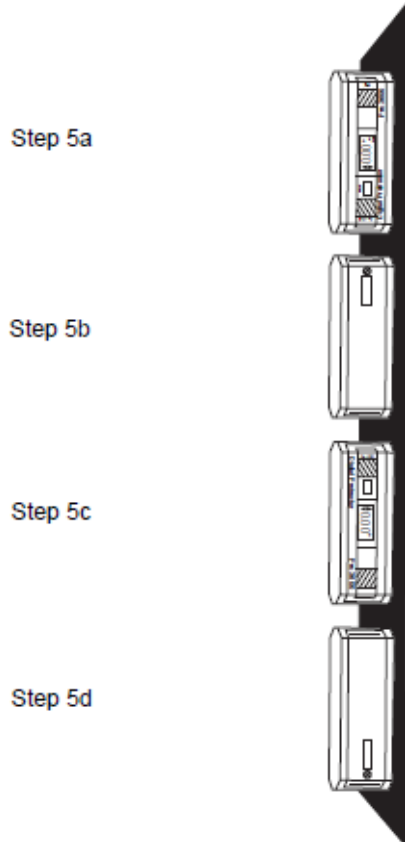

- b. Roll the digital protractor so that it faces away from you. The lettering should still read from bottom to top. Align with the same edge or line. Wait 10 seconds. Press the HOLD button until **[6]** appears.
- c. Rotate the digital protractor end-for-end so that it faces you. The lettering should now read top to bottom. Align with the same edge or line. Wait 10 seconds. Press the HOLD button until **[7]** appears.
- d. Roll the digital protractor so that it faces away from you. The lettering should still read top to bottom. Align with the same edge or line. Wait 10 seconds. Press the HOLD button until **[8]** briefly appears, followed immediately by regular angle measuring.

4.13.4 Installing Digital Protractor Batteries

See [Figure 31](#) for installing batteries.

Figure 31: Digital Protractor

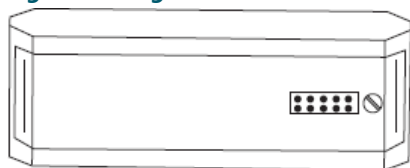

- To install/replace the battery
- Unscrew the battery compartment cover screw.
 - Remove the cover.
 - Install or replace the battery.
 - Replace the cover and tighten the screw.

The digital protractor is powered by a 9-volt battery. A new alkaline battery provides 500 hours of use. A 9-volt lithium battery can be used for even longer life.

To extend battery life, the digital protractor shuts off automatically when left undisturbed for five minutes, unless activity exists on the serial port. To reactivate the digital protractor, push the ON/OFF button.

Note Hooking serial port pin 5 (REQ) to pin 9 (BATT+) disables the auto-power shutoff. The digital protractor also indicates when the battery is low. Change the battery when the display alternately flashes “LobAt” with angle measurements.

The digital protractor does not display inaccurate angles due to a weak battery.

4.13.5 Aligning PAPI Using Bubble-Level/Digital-Level Aiming Devices

Using the bubble-level or digital-level aiming devices to align the PAPI units involves performing horizontal aiming, performing rough elevation setting, checking the horizontal aiming, and performing fine elevation setting.

Preliminary Remarks

The remarks below should be kept in mind in all the following operations: aligning horizontal cutoffs to aiming device, adjusting rough elevation setting, and checking horizontal aiming.

- When handling the unit and, in particular, during installation and aiming, avoid movement of the reference adjusting screws in blocks A and B.

Note Any accidental movement of these screws will require resetting in the factory by specialized personnel.

- When placing the aiming device on the PAPI unit, make sure the holes and slots in the movable arms of the aiming device are properly inserted over the screw heads in the reference blocks (A and B) and into reference slots (C and D).
- The bubble level/digital protractor should be carefully positioned between the locator screws on the bar of the aiming device or against the locator screws on the movable arms.
- When working with the fastening nuts and locknuts on the legs, make sure that the threaded rod does not rotate.

4.13.6 Aligning Horizontal Cut-Offs to Aiming Device

See [Figure 23](#) , Step 1 for the 4-leg PAPI and [Figure 24](#) , Step 1 for the 3-leg PAPI. Horizontal cut-offs are aligned to the aiming device, not the PAPI box.

Note The bubble-level style aiming device is set to the desired elevation setting (3 degrees, 15 minutes), then the PAPI unit is adjusted until the aiming device is level. For the digital-level style aiming device, the digital protractor reads the angular setting of the PAPI box directly. For more detail on the differences between the bubble-style and digital-style aiming devices, refer to *Installation Using Bubble-Level Style Aiming Device* and *Installation Using Digital-Level Style Aiming Device* in this section.

To align the horizontal cut-offs, perform the following procedure:

1. For the bubble-level style aiming device only, first set the aiming device at the required aiming angle for the unit.
2. Open up the two movable arms and place the instrument on the reference blocks A, B, and slots C and D as shown in [Figure 23](#) and [Figure 24](#) . Carry out the following aiming procedure:
 - a. Place rod at 164 feet (50 m) in front of the PAPI unit at the same distance from the runway centerline as reference block B and slot C.
 - b. Check the alignment through the V-sites on bar of aiming device. Use the sighting pictures given in [Installation Using Bubble-Level Style Aiming Device](#) and [Installation Using Bubble-Level Style Aiming Device](#) for the bubble-level aiming device and [Figure 9](#) and [Figure 10](#) for the digital-level aiming device. See [Figure 7](#) . If necessary, adjust alignment of unit by a small movement of the lower hex nut (4).

- c. Tighten upper hex nut (1) on the right front leg F.
- d. Do not tighten lower hex nut (4). Leg F will be the pivot during the following operations.

4.14 Adjusting Rough Elevation Setting

This subsection describes how to adjust the rough elevation for the 4-leg and 3-leg PAPI.

4.14.1 Adjusting Rough Elevation Setting for Four-Leg PAPI System



Note

If the legs of the unit are installed at the same height and are level, the unit will be aimed at approximately 3 degrees.

To adjust the coarse setting of the 4-leg PAPI unit, perform the following procedure:

1. See Step 2, [Figure 23](#) . Place the bubble level/digital protractor between locator screws on the movable arm resting on reference blocks A and B.
2. See [Figure 7](#) and [Figure 23](#) . Level by adjusting the hex nuts (1, 4) on the left front leg E.
3. Tighten hex nuts (1, 4) simultaneously.
4. See Step 3, [Figure 23](#) . Place bubble level/digital protractor between locator screws on the bar of the aiming device resting on reference block B and slot C.
5. See [Figure 7](#) and [Figure 23](#) . Level by adjusting hex nut (4) of the right rear leg G. During this operation, the rigid bottom of the unit must be free from hex nut (1) on the left rear leg H.
6. Position upper hex nut (1) on leg G against upper flat washer (13). Simultaneously tighten hex nuts and on leg G.
7. See Step 4, [Figure 23](#) . Place bubble level/digital protractor between locator screws on the movable arm resting on reference slots C and D.
8. See [Figure 7](#) and [Figure 23](#) . Level by adjusting hex nut (4) on the left rear leg H.
Some adjustment of the upper hex nut (1) may also be required.
9. Position hex nut on leg H against upper flat washer (13).
Simultaneously tighten hex nuts (1, 4).
10. Tighten lower hex nut (4) on leg F.



Note

No further adjustment is required on the hex nuts.

4.14.2 Adjusting Rough Elevation Setting for Three-Leg PAPI System



Note

If the legs of the unit are installed at the same height and are level, the unit will be aimed at approximately 3 degrees.

To adjust the coarse setting of the 3-leg PAPI unit, perform the following procedure:

1. See Step 2, [Figure 24](#) . Place the bubble level/digital protractor between locator screws on the movable arm resting on reference blocks A and B.
2. See [Figure 7](#) and [Figure 24](#) . Level by adjusting the hex nuts (1, 4) on the left front leg E.
3. Tighten hex nuts (1, 4) simultaneously.
4. See Step 3, [Figure 24](#) . Place bubble level/digital protractor between locator screws on the bar of the aiming device resting on reference block B and slot C.

4.14.3 Adjusting Rough Elevation Setting for Three-Leg PAPI System

1. See [Figure 7](#) and [Figure 24](#) . Level by adjusting hex nut (6) of the right rear leg G.
2. Position upper hex nut (1) on leg G against upper flatwasher (13).
Simultaneously tighten hex nuts and on leg G.
3. Tighten lower hex nut (4) on leg F.

4.15 Checking Horizontal Aiming

See [Figure 7](#) . Make sure rod at 164 feet (50 m) from the unit is still properly aligned with the V-sites on aiming bar. If not, loosen upper hex nut (1). Align the unit. Refer to *Aligning Horizontal Cut-Offs to Aiming Device* in this section. Repeat the operations in the preceding section.



Note

It is not necessary for the alignment to be absolutely perfect. An error of 20 inches (508 mm) at 164 feet (50 m) yields an error of 0.5°, which is within tolerance. Refer to *Azimuthal Aiming in Siting Tolerances* in this section.

4.16 Adjusting Fine Elevation Setting

This subsection describes how to adjust the fine elevation setting for the 3-leg and 4-leg PAPI systems.

4.16.1 Adjusting Fine Elevation Setting for Four-Leg PAPI System

To adjust the fine elevation settings using the differential for the 4-leg PAPI, perform the following procedure:

1. Place aiming device on unit so that it rests on the screws of reference blocks A and B, and slots C and D.
2. See [Figure 23](#) , Step 1 and [Figure 7](#) . Make sure the locking hex nuts (6, 8) for the differential (7) on right front leg F are tightened. The locking hex nuts (6, 8) for the differentials on the other legs have to remain loose.
3. See [Figure 23](#) , Step 2 and [Figure 7](#) . Place bubble level/digital protractor on the arm of the aiming device resting on reference blocks A and B. Level by turning the differential on left front leg E in the proper direction. Tighten locking hex nuts (6, 8) on the differential on leg E when leveled.
4. See [Figure 23](#) , Step 3 and [Figure 7](#) . Place bubble level/digital protractor on the bar of the aiming device resting on reference block B and slot C. Proceed with the leveling procedure by adjusting the differential on rear legs G and H, turning both differentials in the same direction with equal amplitude. Tighten locking hex nuts (6, 8) on differential on leg G when leveling is completed.
5. See [Figure 23](#) , Step 4 and [Figure 7](#) . Place bubble level/digital protractor on the movable arm resting on slots C and D. Level by turning differential of left rear leg H in the appropriate direction. Tighten locking hex nuts on differential on leg H when leveling is completed.
6. Repeat the above fine elevation adjustment steps 2 through 5. If the setting is still not correct, go back and repeat the rough elevation adjustment steps and then the fine adjustment steps until the correct setting is obtained.

4.16.2 Adjusting Fine Elevation Setting for Three-Leg PAPI System

To adjust the fine elevation settings using the differential for the 3-leg PAPI, perform the following procedure:

1. Place aiming device on unit so that it rests on the screws of reference blocks A and B, and slots C and D.
2. See [Figure 24](#), Step 1 and [Figure 7](#). Make sure the locking hex nuts (6, 8) for the differential (7) on right front leg F are tightened. The locking hex nuts (6, 8) for the differentials on the other legs have to remain loose.

4.16.3 Adjusting Fine Elevation Setting for Three-Leg PAPI System (contd.)

1. See [Figure 24](#), Step 2 and [Figure 7](#). Place bubble level/digital protractor on the arm of the aiming device resting on reference blocks A and B. Level by turning the differential on left front leg E in the proper direction. Tighten locking hex nuts (6, 8) on the differential on leg E when leveled.
2. See [Figure 24](#), Step 3 and [Figure 7](#). Place bubble level/digital protractor on the bar of the aiming device resting on reference block B and slot C. Proceed with the leveling procedure by adjusting the differential on rear leg G, turning both differentials in the same direction with equal amplitude. Tighten locking hex nuts (6, 8) on differential on leg G when leveling is completed.
3. Repeat the above fine elevation adjustment steps 2 through 4. If the setting is still not correct, go back and repeat the rough elevation adjustment steps and then the fine adjustment steps until the correct setting is obtained.

4.17 Leveling Tilt Switch

The final step in aligning the PAPI unit is leveling the tilt switch.

To level the tilt switch, perform the following procedure:

1. Open the lid.
2. Place a precision bubble level/digital protractor on top of the tilt switch.



Note

The bubble-level and digital protractor are located respectively in the Bubble-Type Level Aiming Device Kit and Digital Protractor-Type Level Aiming Device Kit.

3. Loosen the bolts and adjust the switch up and down until the bubble level/digital protractor reads true.
4. Tighten the bolts.

4.18 Connecting Series Circuit



CAUTION

Before making any wire connections, make sure that you turn off the constant current regulator. Failure to observe this warning may result in personal injury, death, or equipment damage.

This subsection describes series circuit wiring requirements.

4.18.1 Grounding Units

Each PAPI unit must be grounded. To ground each unit: Attach a ground wire AWG #12 (minimum) to the ground lug located on the floor flange on the rear PAPI unit leg.

4.18.2 Using Isolation Transformers

One or two L-830 isolation transformers are required to connect the series lighting circuit to each PAPI unit.



Note

Refer to [Table 4](#) and [Table 5](#) for isolation transformer requirements.

4.18.3 Connecting External Wiring

All installation wiring should conform to the applicable sections of the National Electric Code and Local Codes. Make wire connections as shown in "Wiring Schematics and Installation Drawings" on page 67. Route cable through the bottom holes of the box assemblies.

Note All external wiring must be a minimum of 16 AWG/600 V.

See Figure 32 for suggested method of connecting the wires between the transformer housing and the PAPI unit and the equipment that the contractor supplies. A field splice kit is provided for L-880 installation and for L-881 PAPI installation. Each field splice kit provides enough items for a single light unit.

Note If the field splice kit is installed without conduit, install using cordgrip. It is important that the tilt switch wires be free from nicks and routed in such a manner as to minimize conducted interference between adjacent wires. After making all wiring connections and checking the operation of the units, install duct seal or RTV in all conduit entrances

Figure 32: PAPI External Connections (Two- and Three-Lamp)

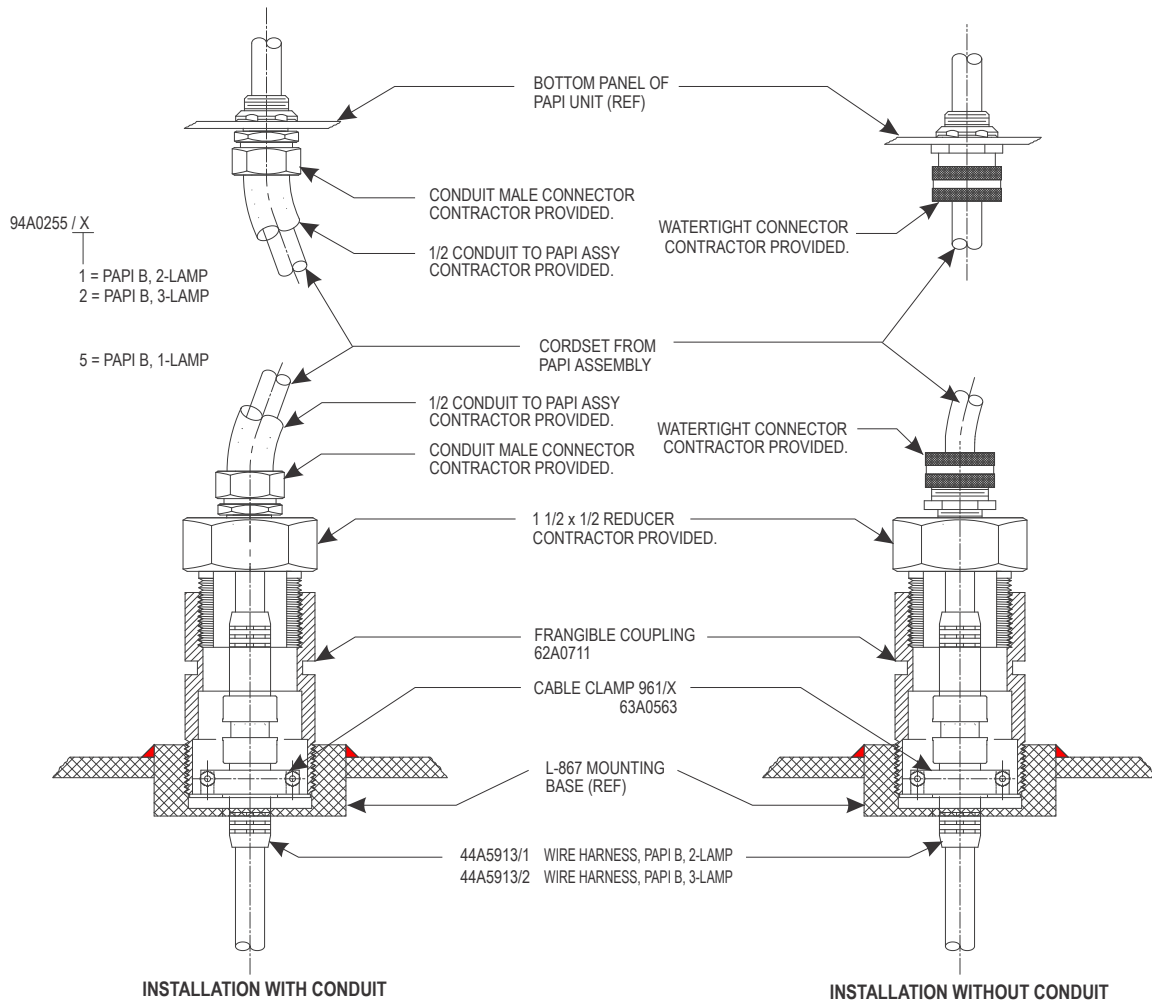

4.19 Checking Slope Angles of PAPI Units

It may be requested that when the equipment is put initially into operation and at regular intervals thereafter, the cut-off angle of the units be checked. To make this measurement, it will be necessary to use a surveying instrument or a bubble level with telescope and a surveyor's stake.

To check the slope angles of the PAPI units, perform the following procedure:

1. See [Figure 33](#) . Place the surveying instrument 6 to 10 feet (1.83 to 3.05 m) behind the unit pointing down beam.

Figure 33: Checking Slope Angles

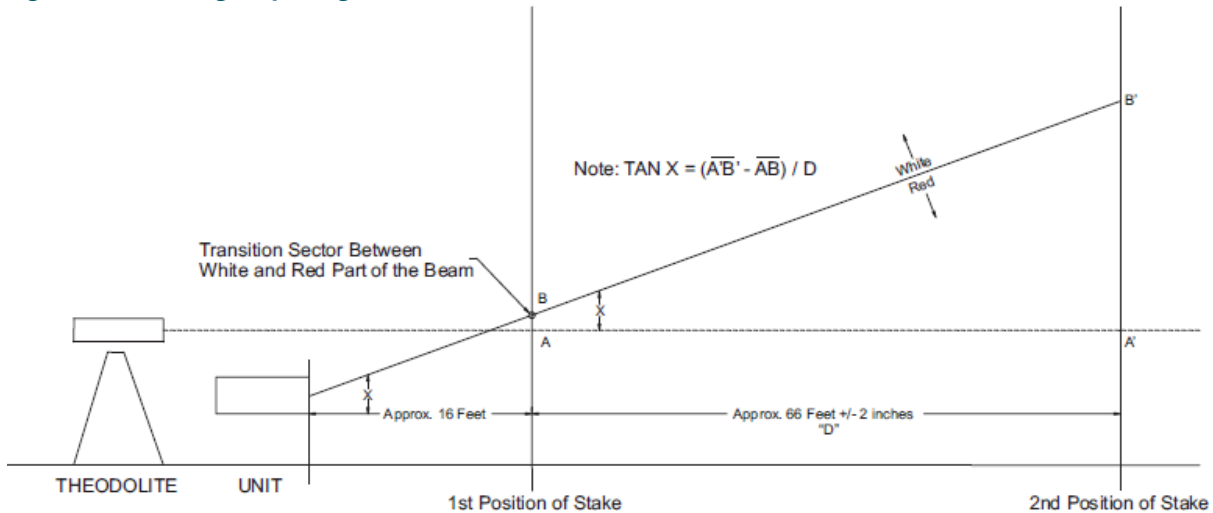

2. A surveyor's stake is held by an assistant approximately 16 feet (4.88 m) in front of the unit.
3. Take reading *A* for the intersection of the horizontal of the telescope with the stake.
4. Take reading *B* for the intersection of the cut-off plane of the light beam with the surveyor's stake.
5. The assistant should now move a precisely measured distance of about 50 to 66 feet (15 to 20 m) ($\pm 0.25\%$) down beam and take the same measurements *A'* and *B'*, as in steps 3 and 4 above.



Note

The angle *x* of the beam cut-off to the horizontal is found from the following formula: $\tan x = (\overline{A'B'} - \overline{AB}) / D$



Note

The overline (—) denotes length where *D* is the horizontal distance between the two stake positions. If similar checks are to be scheduled in the future, a small concrete pad holding a galvanized pipe may be installed in front of each unit at the distances used above.

4.20 Using Reference Bases for Checking Stick

See [Figure 8](#) . As soon as the system is found to be operationally acceptable in all respects, install permanent sighting bases in front of each light unit to allow for routine checks of the elevation setting using the checking stick.

4.20.1 Locating Reference Bases

To locate a reference bases, perform the following procedure:

1. Locate a concrete sighting base on the extended centerline of each unit.
2. When the PAPI is switched on, walk along the centerline of the unit observing it from time to time through the screen on the checking stick until the lower limit of the white sector is about to disappear under the lower scored line.

3. At this point, dig a hole approximately 16 inches (406.4 mm) square and 12 inches (304.8 mm) deep.
4. See [Figure 18](#) and [Figure 19](#) for the two-lamp/three- and four-leg and [Figure 20](#) and [Figure 21](#) for the three-lamp/three- and four-leg PAPI. Drive a steel pipe vertically in the center of the hole until its top is at ground level.
5. Place the bottom end of the checking stick on top of the pipe and observe the light unit through the screen.
6. Gradually drive the pipe into the hole, while frequently observing the light unit through the screen, until the light beam no longer appears completely white just below the upper line of the screen.
7. Repeat this procedure for the other units, using the same observer.

4.20.2 Making Observations with Checking Stick

See [Figure 8](#) . Refer to *Reference Bases for Checking Stick* in this section. Place the checking stick on concrete sighting base in front of the light unit and switch the PAPI system on. Observe the light unit through the screen. Just below the upper line of the screen, the light beam should no longer appear completely white. If this is not the case, the unit is out of alignment and requires resetting. Refer to *Aligning Units* in this section.

4.20.3 Making Flight Checks for Reduced Horizontal Coverage

A flight check is required for the PAPI system when there is reduced horizontal coverage to determine if all horizontal cutoffs of the PAPI beams are properly located relative to any obstacles. If horizontal realignment is required, the upper and lower locknuts on all PAPI legs must be loosened and the unit realigned. Refer to *Aligning Horizontal Cut-Offs to Aiming Device* in this section.

5.0 Operation

This section provides operating information for the PAPI system and the aiming device digital protractor.

5.1 Operating PAPI System

This subsection provides information concerning PAPI normal operation, regions with heavy snowfall, and criteria for system deactivation.

5.1.1 Normal Operation

The PAPI system must operate continuously as long as the runway is in service. At night the system may operate continuously at any intensity selected by the CCR.

5.1.2 Regions with Heavy Snowfall

Units should operate continuously at normal standby brightness even when the runway is not in use. Any snow will thus melt and drain off. When snowfall is expected to bury the units, the location of the units should be marked with sticks or flags (approximately 7 feet high) (2.13 m) to prevent damage to the units by snow removal equipment.

5.1.3 Criteria for System Deactivation

Pending repair and provided it is continually monitored, a unit in which one of the lamps has failed can still be regarded as operational. Should the system show more serious defects, it must be put out of operation.

5.2 Operating Digital Protractor

This subsection provides information for operating the digital protractor. The digital protractor is a part of the digital-level style aiming device. For more information on calibrating, maintaining, installing, and using the digital protractor, refer to *Calibrating Digital Protractor* and *Installing Digital Protractor Batteries* in the *Installation* section, and *Maintenance Schedule* and *Cleaning and Storing Digital Protractor* in the *Maintenance* section.



CAUTION

- Digital-Level device protractor must be calibrated before each use to insure accuracy.
- See "Calibrating Digital Protractor".

To operate the digital protractor, perform the following procedure:

1. See [Figure 27](#) . Push the ON/OFF button. The digital protractor displays angle readings immediately.



Note

See [Figure 34](#) . When the unit is first turned on, the displayed angles are in standard reference mode. The true horizontal level is displayed as 0.00° . An arrow on the left side of the display indicates which way to move the digital protractor to achieve level or plumb.

Figure 34: Digital Protractor Initial Angle Displayed

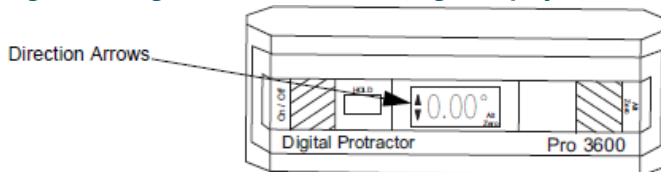

2. Set the digital protractor on the surface to be measured and read the angle.



Note

To get the most accurate reading, allow the unit to settle for 5 seconds before noting the angle.



Note

Expect a resolution of one hundredths of a degree for ±10 degrees of level. The resolution automatically changes to tenths of a degree beyond these points.

5.3 Wiring Schematics and Installation Drawings

This section provides wiring schematics for the Style B L-880/L-881 PAPI systems. Refer to [Table 11](#) to locate a particular wiring schematic.

Table 11: Locating Wiring Schematics

To locate this wiring schematic...	See this Figure...
PAPI Style B Master and Slave Typical Installation 3-lamp External Wiring	Figure 35 - Figure 36
PAPI Style B Master and Slave Typical Installation	Figure 38 - Figure 39
Two- and Three-Lamp PAPI Optical Box Internal Wiring (A)	Figure 41

Figure 35: PAPI Style B Master and Slave Typical Installation 3-Lamp External Wiring

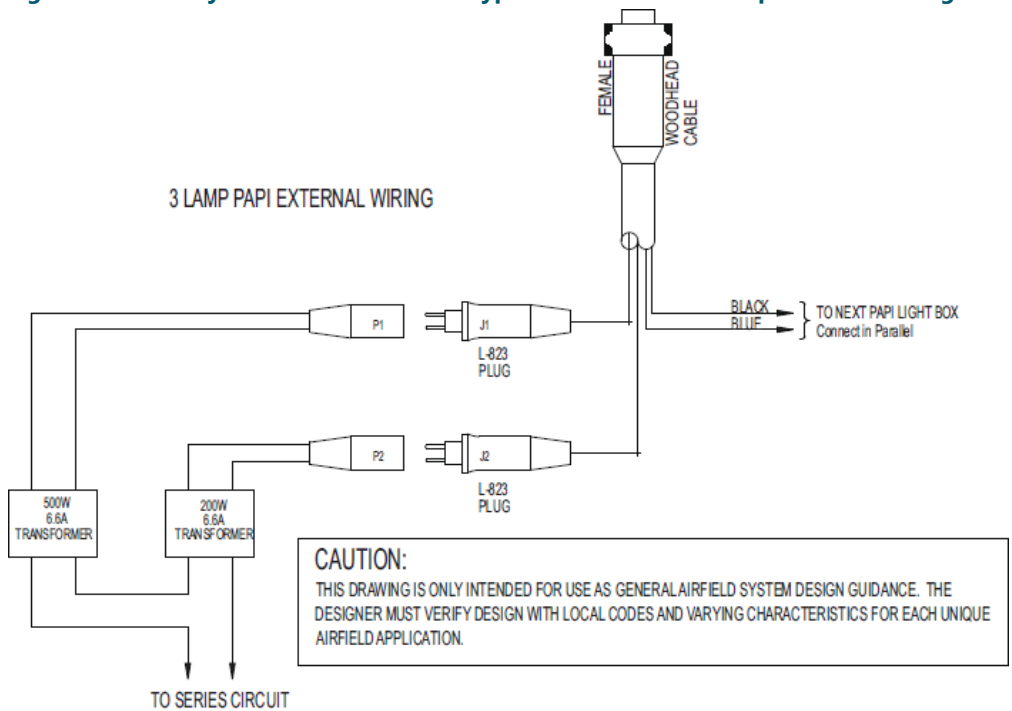

Figure 36: PAPI Style B Master and Slave Typical Installation 2-Lamp External Wiring

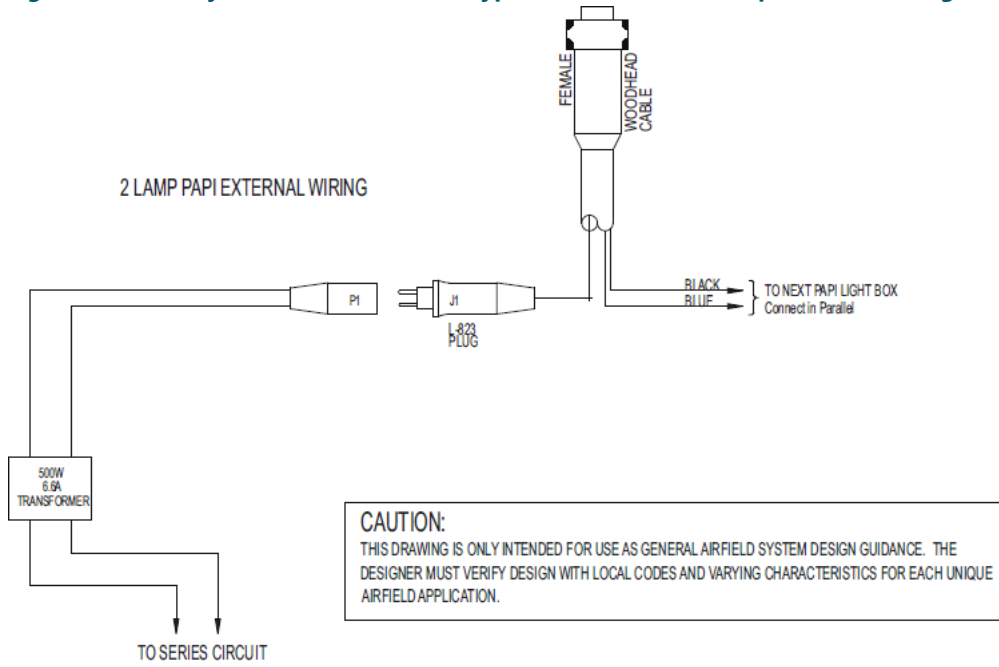

Figure 37: PAPI Style B Master and Slave Typical Installation

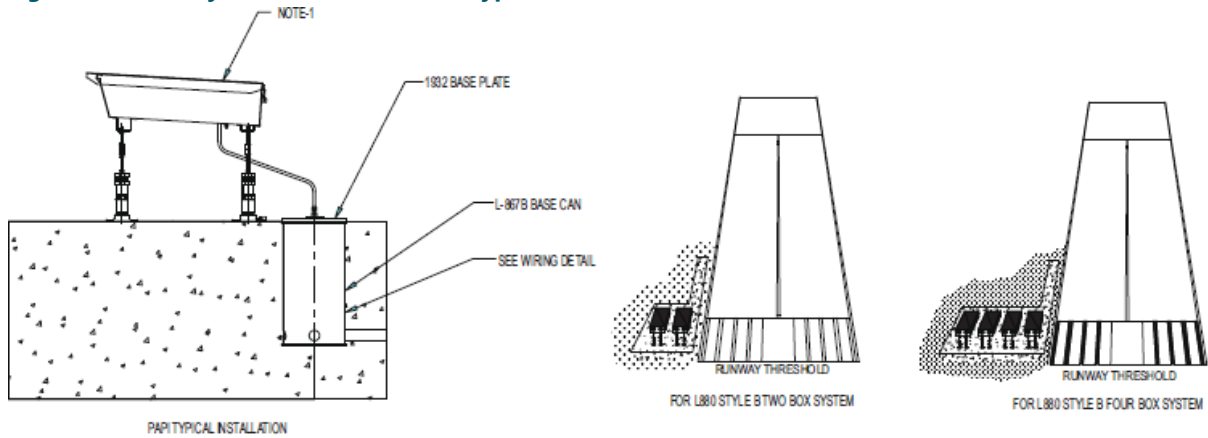

Figure 38: PAPI Style B Master and Slave Three-leg Foundation Detail

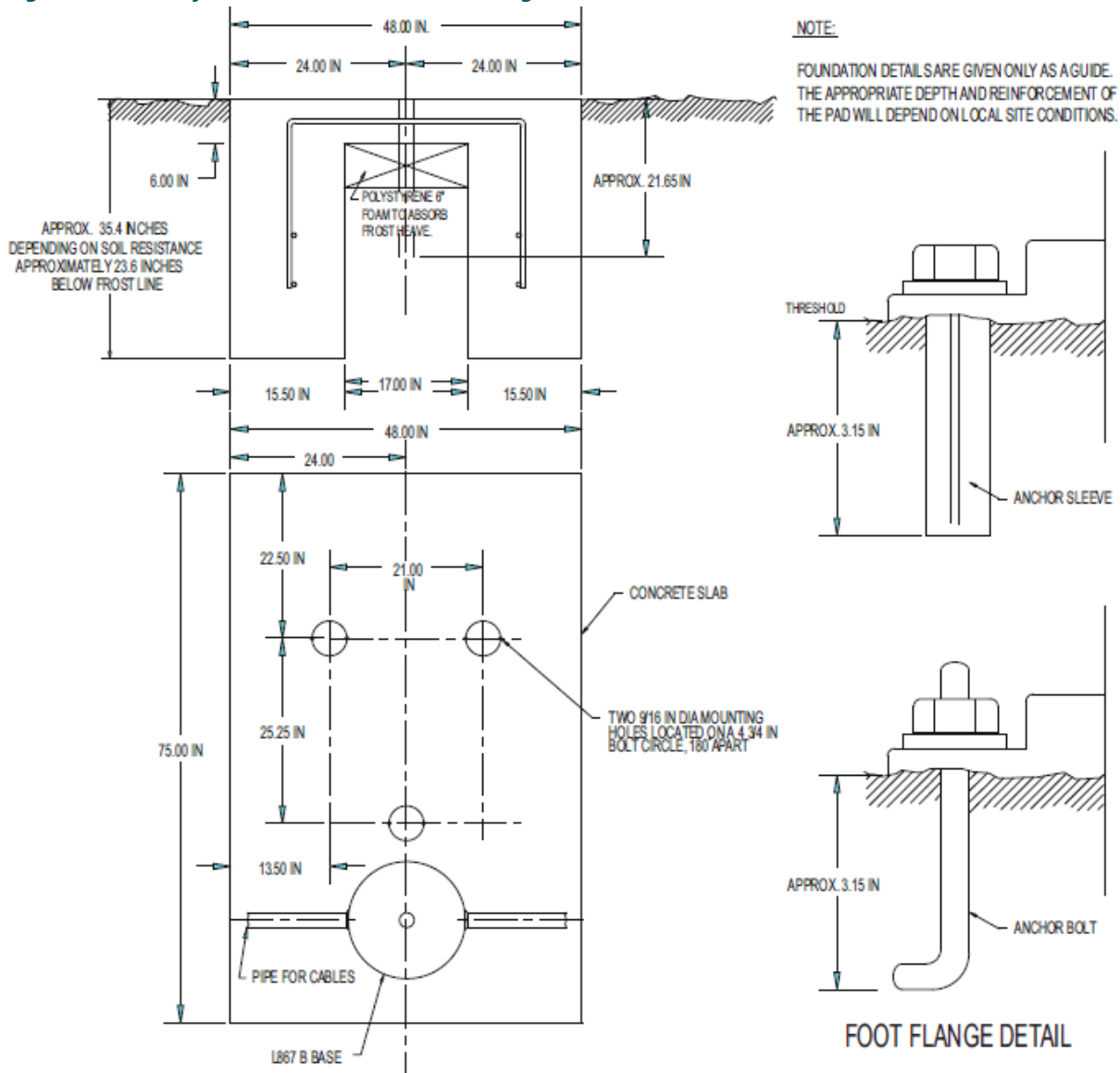

Figure 39: PAPI Style B Master and Slave Four-leg Foundation Detail

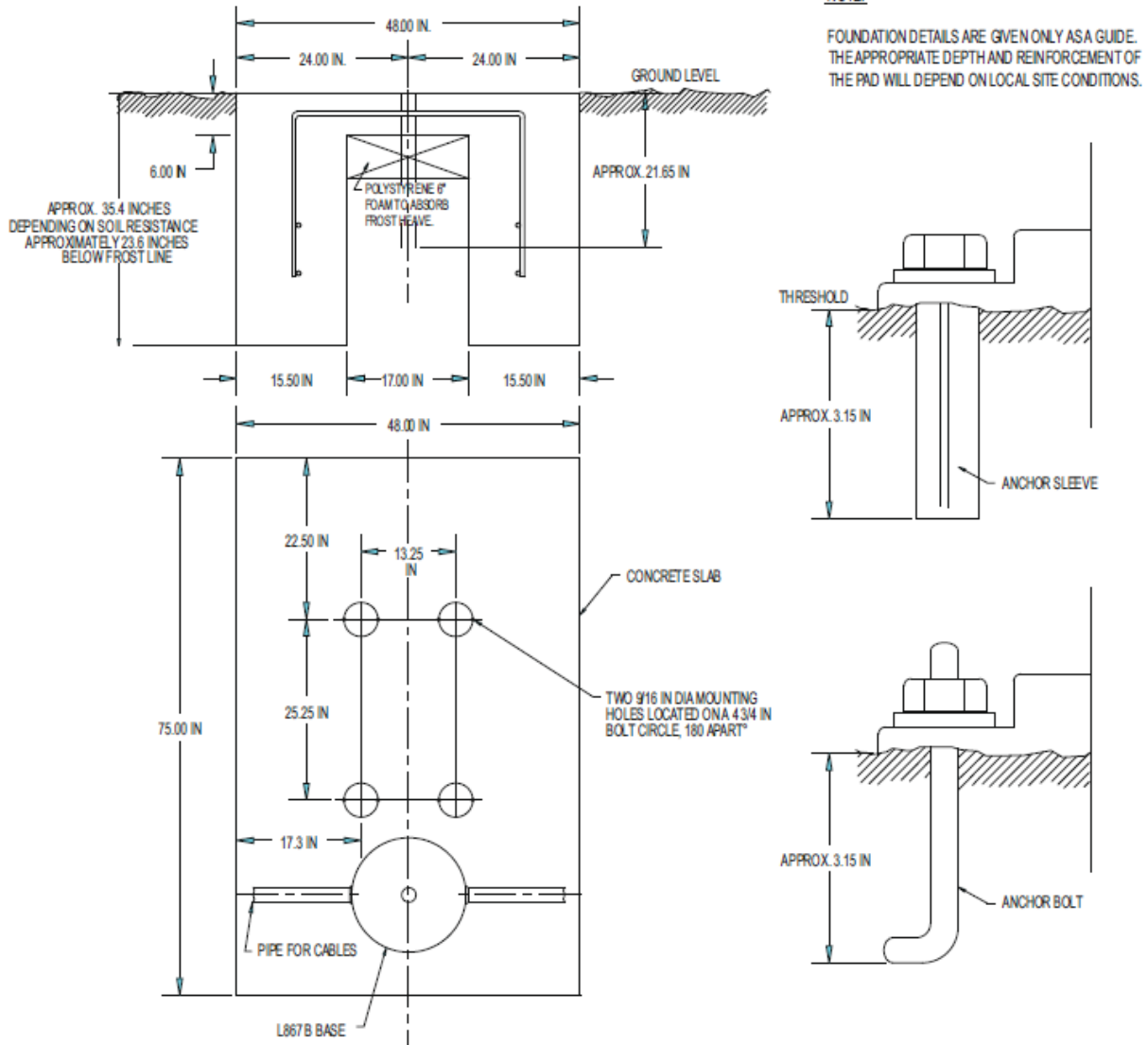
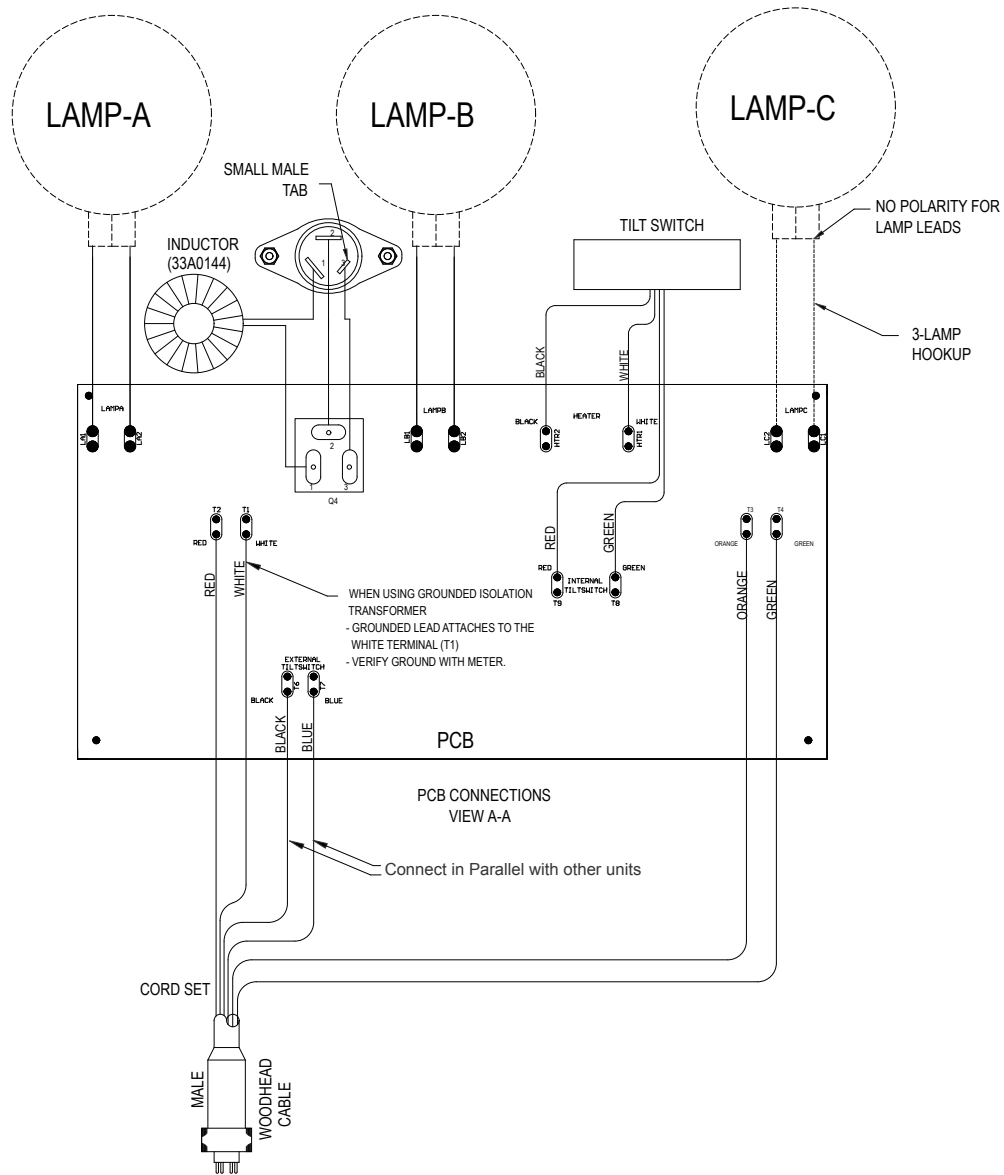

Figure 40: Two- and Three-Lamp PAPI Optical Box Internal Wiring



6.0 Maintenance

This section provides maintenance information for the Style B L-880/L-881 PAPI systems.

6.1 Maintenance Schedule

Refer to [Table 12](#) for the Style B L-880/L-881 PAPI maintenance schedule.

Table 12: PAPI Maintenance

Interval	Maintenance Task	Action
After initial installation (during first few weeks)	Check elevation angle of units. (bubble type)	For the bubble-level style aiming device only, use that checking stick that comes in the Bubble-Type Level Aiming Kit. Reset any units out of alignment.
	Check elevation angle of units. (digital)	For the digital-level style aiming device, check the digital protractor calibration and verify the unit elevation aiming with aiming device and digital protractor located in the Digital Protractor-Type Level Aiming Kit. SEE CAUTION BELOW
Daily	Check for frost or dew on outer lens if units are not operated continuously.	Remove frost or dew and change airport lighting circuitry per Cert Alert 02-08. See NTSB Cert Alert FAA Cert Alert No. 02-08 in Section 1
	Check to ensure all lamps are lighted and illuminated evenly.	(1) Replace burned-out lamps. Clean any dirty glassware.
	Check for any apparent evidence of damage to unit caused by being hit by a mower or other vehicle or if the tilt switch has deactivated the system	(2) Repair or replace any damaged components. Verify the unit elevation aiming. SEE CAUTION BELOW
	Check all control equipment for proper operation	(3) Repair or replace any damaged components
<div style="border: 1px solid black; padding: 10px;">  <p>CAUTION</p> <ul style="list-style-type: none"> Digital-Level device protractor must be calibrated before each use to insure accuracy. See " Installation Using Digital-Level Style Aiming Device " </div>		
Weekly (or more frequently because of inclement weather)	Clean outer surface of protective glass.	(1) Use a soft cotton cloth moistened with alcohol.
	Check elevation angle of units.	(1) For the bubble-level style aiming device only, use that checking stick that comes in the Bubble-Type Level Aiming Kit. Reset any units out of alignment. For the digital-level style aiming device, check the digital protractor calibration and verify the unit elevation aiming with aiming device and digital protractor located in the Digital Protractor-Type Level Aiming Kit. SEE CAUTION BELOW

Table 12: PAPI Maintenance (Continued)

Interval	Maintenance Task	Action
Monthly	Inspect housing and closure system, lamps, electrical connections, filters, and protective glass for damage, breakage, or warping.	(1) Repair or replace any damaged parts.
	Clean interior.	(2) Remove any foreign matter. Clean both sides of the protective glass, color filters, lenses and reflectors. Use a soft cotton cloth moistened with alcohol.
	Make sure mounting is rigid.	(3) Tighten any loose hardware, nuts, screws, etc. Realign unit if hardware has loosened.
	Make sure no vegetation obscures the light beams.	(4) Remove vegetation. Use weed killer to prevent any additional growth.
	Make flight check of system, if possible.	(5) Verify that units give proper approach path indication. Re-aim if needed. SEE CAUTION BELOW



CAUTION

- Digital-Level device protractor must be calibrated before each use to insure accuracy.
- See “ [Installation Using Digital-Level Style Aiming Device](#) ”.

6.2 Maintenance Procedures

Refer to maintenance procedures below.

6.2.1 Replacing Lamp

To replace a lamp, perform the following procedure:

1. Turn off the CCR that powers the PAPI system.
2. Disconnect the electrical slip-on fitting on burned-out lamp, swing back the spring-loaded fork, and remove the lamp from the reflector.



Note

Replacement lamps shipped after May 1, 2005 will include extra male disconnects. Replacement lamp(s) 48A0077-1 will have female disconnects. If the lamps being replaced have male disconnects, then the female disconnects on the power leads must be cut off and replaced with the male disconnects supplied in the Replacement Lamp Kit (94A0337). If the lamps being replaced have female disconnects, then disconnects on the power leads do not need to be replaced.

3. Install a new lamp into the electrical slip on the fitting.



CAUTION

Make sure that the lamp wires do not touch any components on the PCB, or any internal wires. The components may be burned.

4. Orientate lamp to match index slots in lamp base with index tabs in lamp holder (one tab/slot is square, the other tab/slot is circular). Hold lamp in place by placing the forked spring clip over lamp base and locking spring clip in place by latching forked spring clip behind the locking ears located on side of lamp holder.



CAUTION

Wear cotton gloves when handling the lamps. Touching the quartz bulb with bare fingers may seriously shorten lamp life. If the quartz bulb has been touched, wipe it carefully with lens cleaning tissue or similar material moistened with isopropyl alcohol.



Note

It is recommended that a systematic replacement of all lamps be made after a service period of approximately 800 hours at the 100% brightness level. An elapsed-time recorder connected to the constant current regulator may be used to determine the time for replacement.

6.2.2 Replacing Objective Lens

The objective lenses are precisely positioned in the unit and are not field repairable since the optical center of the lens must be realigned after replacement. Whenever an objective lens is damaged, the PAPI light unit must be returned to the factory for repair and adjustment. Contact ADB Safegate, Sales Department for details.

6.2.3 Replacing Filters

The filters must be perfectly clean. Use a soft cotton cloth moistened with alcohol to clean filters, and wear cotton gloves when handling filters.



Note

When cleaning filters, make sure each filter is returned to the same filter holder from which it was removed.

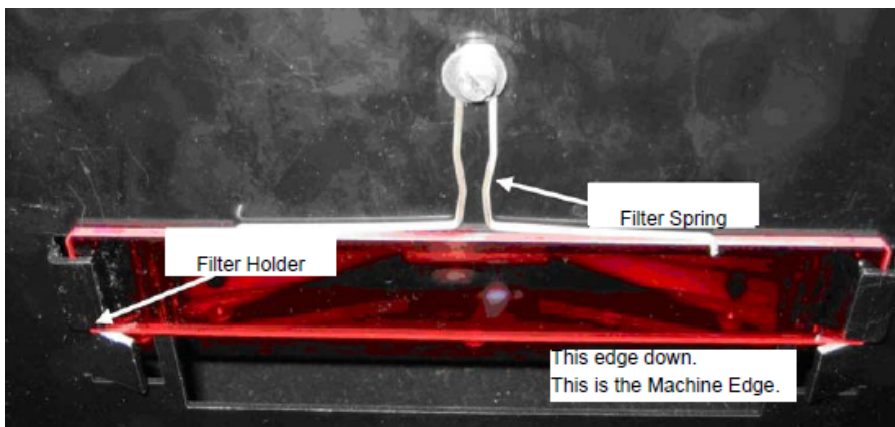

Each filter is held in place in the filter holder by two springs.

To remove or replace a filter, perform the following procedure:

1. Remove the two springs using small pliers.
2. Unclip the lower end of each spring from the hole in the panel and pull upward on the other end of the spring to remove.
3. Remove the filter by sliding it upward out of the holder.
4. To reinstall filter, reverse the removal steps. The filter must be installed in the holder so that the lower edge (dull edge) of the filter is down.

6.2.4 Cleaning and Storing Digital Protractor

Refer to the guidelines below for cleaning and storing the digital protractor used for aiming the PAPI.

- Clean the digital protractor with mild liquid soap applied to a damp cloth.

Never immerse the protractor in water.

- Do not use solvents directly on any of the digital protractor plastic surfaces.
- Store the digital protractor away from extreme temperature.



CAUTION

Never store digital protractor below $-20\text{ }^{\circ}\text{C}$ ($-4\text{ }^{\circ}\text{F}$) or above $65\text{ }^{\circ}\text{C}$ ($149\text{ }^{\circ}\text{F}$).

7.0 Troubleshooting



WARNING

Electrical Shock

- Allow only qualified personnel to perform the following tasks. Observe and follow the safety instructions in this document and all other related documentation.
- De-energize the circuit and lock out the circuit or regulator so that the circuit cannot be energized by remote means before attempting to service the fixture.

Failure to follow these warnings may result in equipment damage or personal injury, including death.

This section contains troubleshooting information. This information covers only the most common problems that you may encounter. If you cannot solve the problem with the information given here, contact your local ADB SAFEGATE representative for help.

Refer to [Table 13](#) .

Table 13: Style B L-880/L-881 PAPI Troubleshooting

Problem	Possible Cause	Solution
All lamps out	PAPI boxes tilt	Realign PAPI boxes.
	Tilt switch not level	Realign tilt switch.
	Power input	Repair or replace loose or broken wire.
	All lamps failed	Replace lamps. Check output current level. Calibrate, if necessary.
	PCB has failed.	Replace PCB.
Lamp(s) dim	Dirty lens shield	Clean with soft cotton cloth moistened with alcohol.
	Lamp not properly seated in reflector	Re-seat lamp in reflector. Replace lamp socket, if necessary.
	Current level too low	Calibrate, if necessary.
	Lens is improperly aligned	Replace lens if loose in ring.
	Unit improperly aligned	Use check stick to check alignment.
Signal Interruption when PAPI unit is not operated continuously	Frost or Dew on outer lens	Change airport circuitry to ensure PAPI's are preset to operate on a low power setting of either 5 or 20 per cent. See "FAA Cert Alert" on page iv.
Short lamp life	Current level is too high	Check output current level. Calibrate, if necessary.
Tilt switch circuitry tilted	Tilt switches incorrectly wired	Correct wiring.

8.0 PAPI B Parts

To order parts, call ADB SAFEGATE Customer Service or your local representative. Use the parts list, and the accompanying illustration, to describe and locate parts correctly.

Ordering Code PAPI Style B 4 4 A 5 8 6 0 /

Power

2 = Style B (Current Powered)

Style

1 = L-880 (4 Box)

2 = L-881 (2 Box)

Lamp

1 = 2-Lamp Optical Box

2 = 3-Lamp Optical Box

Legs

1 = Three Legs

2 = Four Legs



Notes

- Each PAPI system requires a digital aiming device kit, which is ordered separately.
- Reference NTSB Cert Alert No. 02-08 dated Dec. 12, 2002, regarding prevention of the possibility of dew or frost forming on the light unit optics: At airports where PAPI units are activated when needed and thus are not operate continuously, change airport lighting circuitry to ensure PAPIs are preset to operate continuously on a low power setting, either 5 percent or 20 percent of full intensity as necessary for local site conditions.

Ordering Code Digital Aiming Device 44A6031

8.1 Style B L-880/L-881 PAPI Part Numbering System

Refer to [Table 14](#) for the optical box assembly part numbers for the 2-lamp and 3-lamp L-880 and L-881 Style B PAPI systems.

[Table 14](#) shows how to determine the part number for a particular L-880/L-881 PAPI system.



Note

Substitution of electrical components may be done only if substitution is the exact physical equivalent (body or case size) and equal, or better electrical characteristics with respect to tolerance, failure rate, and/or reliability.

Table 14: Style B L-880/L-881 Optical Box Assembly Part Numbers

Component	Part Number
2-lamp optical box assembly	44A5861-1 *
3-lamp optical box assembly	44A5861-2 ¹

Notes

* For reference only. Use this to determine the number of spares. Channel specific parts will increase by one for a three channel PAPI. Do Not Order this part/assembly.

8.2 Optical Box Final Assembly Parts List

Figure 41: Optical Box Parts and Details

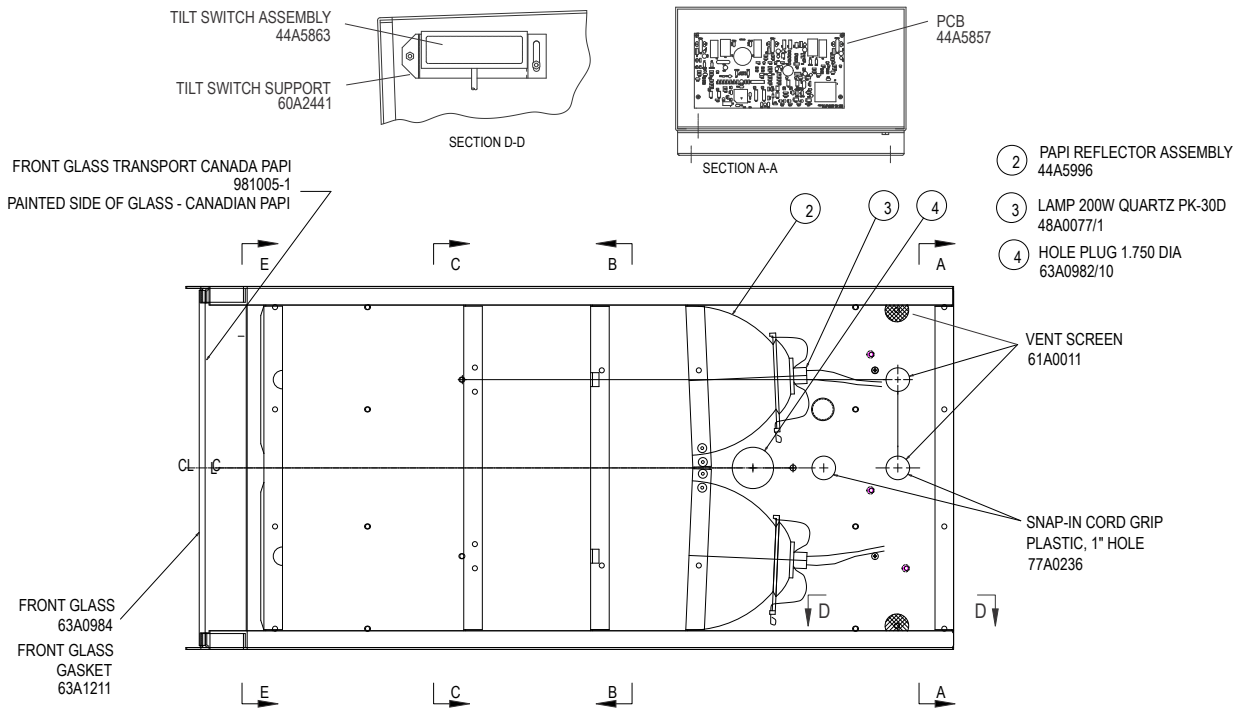

Figure 42: Optical Box Part Detail B-B

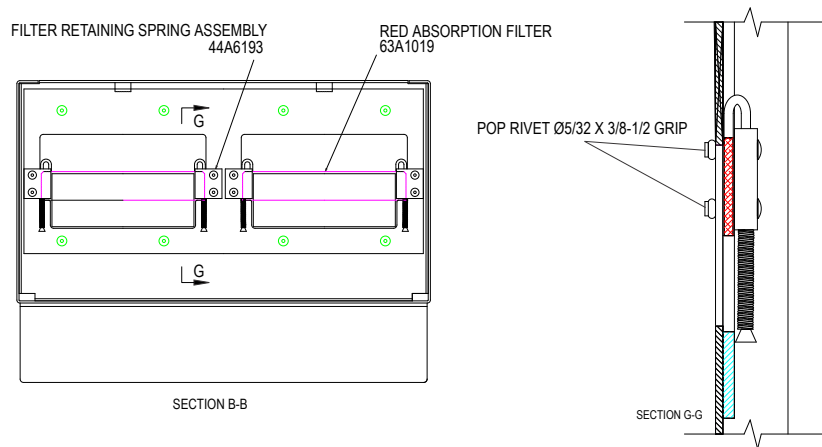
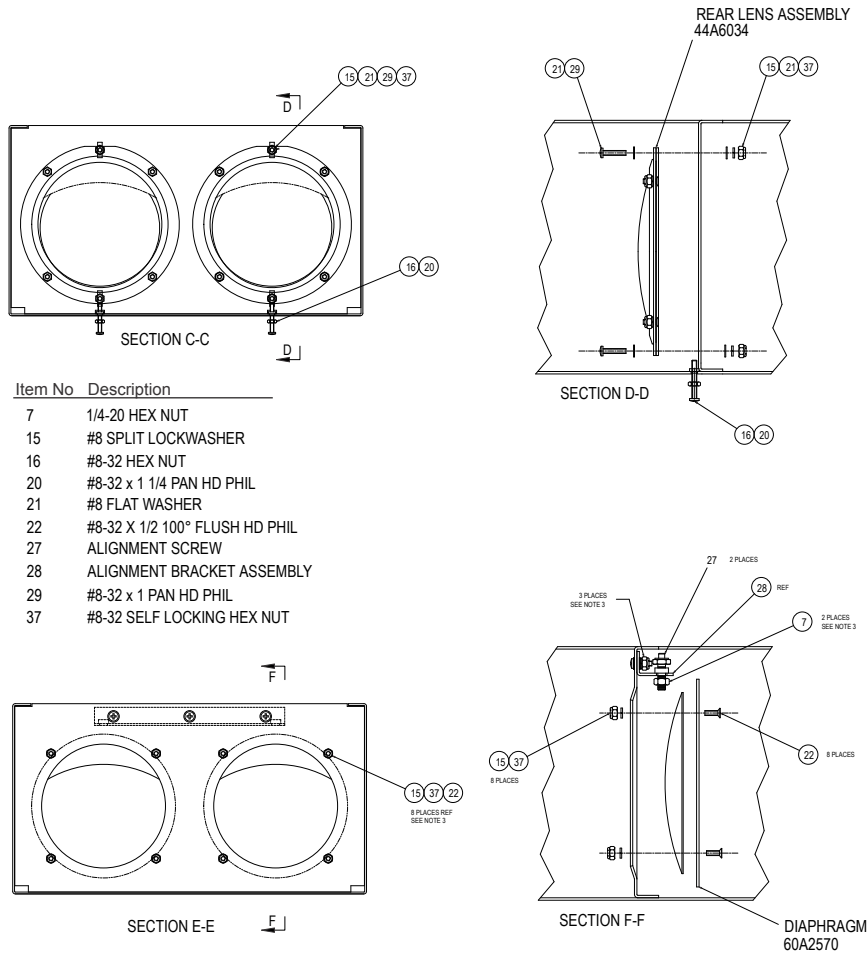

Figure 43: Optical Box Parts Detail C-C, E-E



8.3 Optical Assembly Parts List

Table 15: Lamp Reflector Assembly Parts

Description	Part Number	Quantity	Note
Protective glass	63A0984	1	
Gasket for outer protective glass	63A1211	1	
Two-lamp lens	44A6034	2	A
Three-lamp lens		3	
Two-lamp filter	1438.12.220 Canada	2	A
Three-lamp filter	63A1019 FAA	3	
Two-lamp reflector	44A5996	2	A
Three-lamp reflector		3	

Notes

Table 15: Lamp Reflector Assembly Parts (Continued)

Description	Part Number	Quantity	Note
-------------	-------------	----------	------

^A Trained Qualified Personnel installation only.

Figure 44: Optical Box Side View

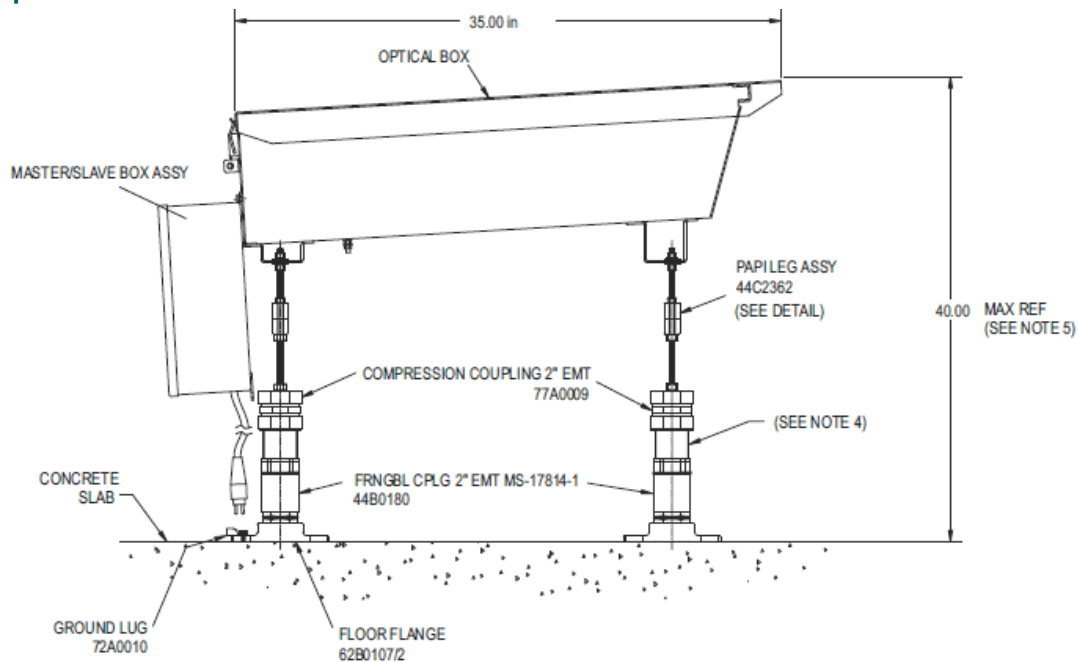

NOTES: from 44A4743:

#4: 2 inch EMT diameter (2 3/16 O.D.) Tube to be supplied and installed by contractor. Length to be determined at installation to adjust for uneven terrain and to mount light box at the correct elevation above runway. 2" EMT tube to extend 3 1/4 inches into item M1 and 1 1/2 inches into item M5 to insure straight installation. Tube must be painted int. orange FED. STD. 595A, Color# 12197 to reduce corrosion.

#5: See AC 150/5345-28 for exceptions

#7: Contractor to supply flexible conduit and couplings for cord sets to power supply and master/slave.

#8: See 43B1649 and 43B1650/2 for slave/master wiring.

#9: The nominal cord set length is 72 in. Since the length required for installation depends on the height of the PAPI unit and distance of the bottom of the unit from the wire entry point in the can or conduit, the customer should check the length required. If a longer or shorter cord set is required, the wires may be spliced (in accordance with local codes)

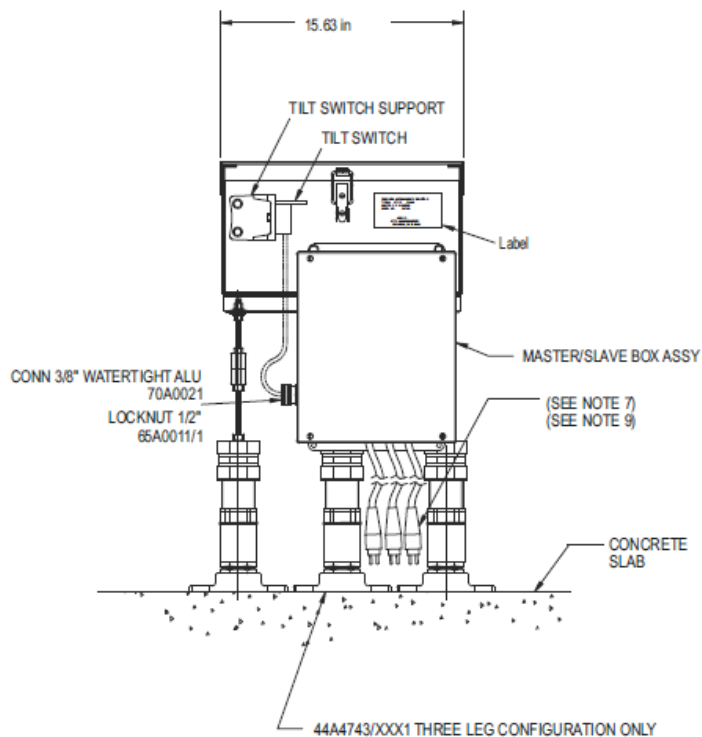

8.4 Adjustable Leg Parts

See [Figure 45](#) . Leg assembly part number is 44C2362/SS.

Figure 45: Adjustable Leg 43C2362/SS

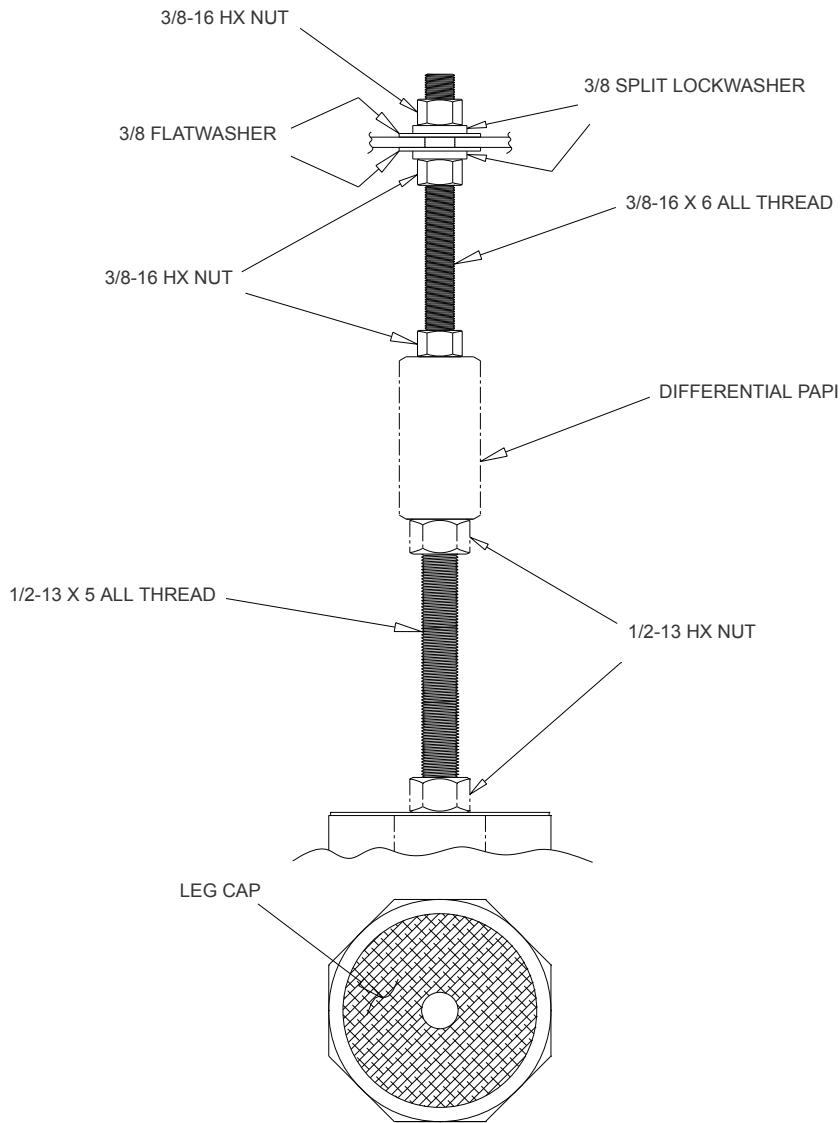
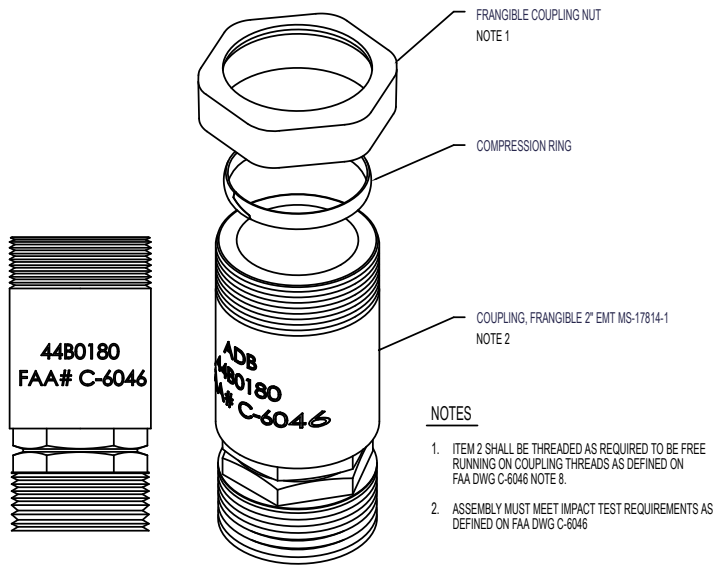

Figure 46: Frangible Coupling 44B0180



- NOTES**
1. ITEM 2 SHALL BE THREADED AS REQUIRED TO BE FREE RUNNING ON COUPLING THREADS AS DEFINED ON FAA DWG C-6046 NOTE 8.
 2. ASSEMBLY MUST MEET IMPACT TEST REQUIREMENTS AS DEFINED ON FAA DWG C-6046

8.5 Field Splice Kit Parts List

See [Figure 47](#) for the Style B L-880/L-881 PAPI field splice kit. Field splice kits are provided as required. Wiring harnesses are shown in [Style B L-880/L-881 PAPI Part Numbering System](#) thru [Figure 44](#) in the *Wiring Schematics* section.

Table 16: Splice Kit Parts

Item	Description	Part Number	Quantity Per Kit 94A0255-1	Quantity Per Kit 94A0255-2	Note
1	Frangible coupling	62A0711	1	1	
2	Cable clamp, 961-X	63A0563	1	1	
Wiring harness					
3	Wiring harness, Style B, 2-lamp	44A5913-1	1		
	Wiring harness, Style B, 3-lamp	44A5913-2		1	
NS	Butt splice	71A0054	2	2	
NS	Heat shrink tube	71A0072	1	1	

Table 16: Splice Kit Parts (Continued)

Item	Description	Part Number	Quantity Per Kit 94A0255-1	Quantity Per Kit 94A0255-2	Note
NS	Aluminum adapter, 2-6 poles	70A0518	1	1	A

NOTE A: The aluminum adapter is used only if the frangible coupling is not used.
NS: Not Shown

Figure 47: Field Splice Kit 94A0255/X

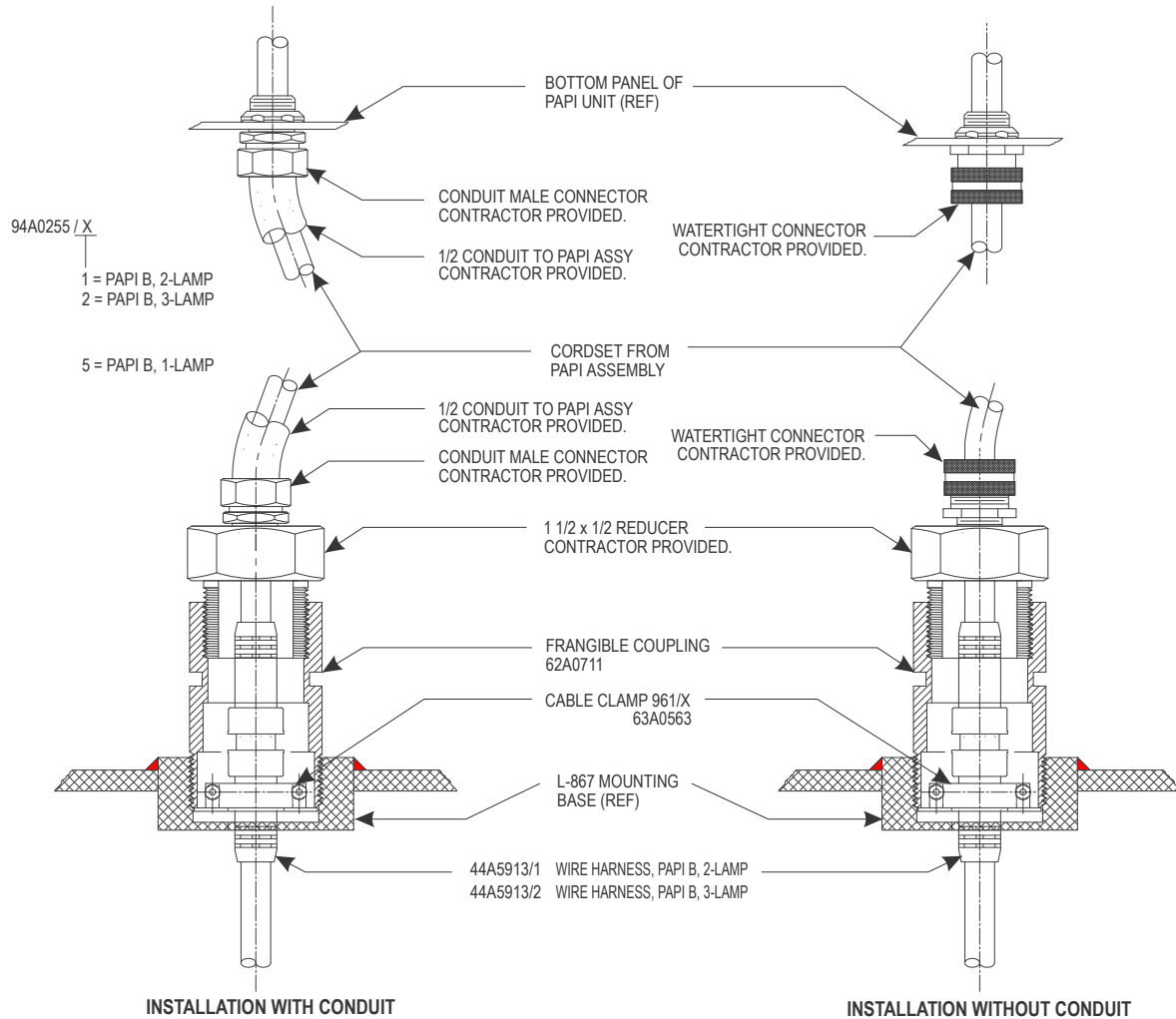

Refer below for aiming device kit parts list.

Table 17: Aiming Device Kit Parts List

Item	Description	Part Number	Quantity	Note
NS	Aiming Device Kit, digital-level style	44A6031	1	

NS: Not Shown

8.6 PAPI B Spare Parts

Table 18: PAPI-B Spare Parts

Description	Part Number	Quantity	Note
Optical box			
Optical box, 2-lamp	60A2443	1	
Optical box, 3-lamp	60A2442	1	
Lamp, 200 W, 6.6 A		See note.	
Lamp (for two-lamp optical box)	48A0077-1	2	A
Lamp (for three-lamp optical box)		3	
Gasket, 5/8 X 1/8 CC neoprene, black	RM0488	2	
Heat shield		1	
Heat shield, two-lamp	60A2614-1		
Heat shield, three-lamp	60A2614-2		
Vent screen, 1-inch	61A0011	See note.	B
PCB (2-lamp and 3-lamp)	44A5857	1	
Choke, custom, 19T, 33uH nominal, PAPI-B	33A0144	1	NS
Standoff, hex M-F, #6–32 X ¾	66A0129	4	
Isolated triac	28A0026	1	
Filter sieve	61A0311-02	1	
Grommet, 1-inch	63A0247	1	
Tilt switch assembly	44A5863	1	
Adjustable leg assembly		See note.	
Three-leg assembly	44C2362/SS	3	C
Four-leg assembly		4	
Frangible coupling assembly		See note.	
Three-leg coupling assembly	44B0180	3	C
Four-leg coupling assembly		4	
Base flange		See note.	
Three-leg flange	62B0107-2	3	C
Four-leg flange		4	

NOTE A: Two required for two-lamp assembly; three required for three-lamp assembly. Refer to *Replacing Lamp in Maintenance Procedures* in Section 5, *Maintenance*.

NOTE B: Quantity of 1 for two-lamp; quantity of 2 for three-lamp.

NOTE C: Three required for three-leg assembly; four required for four-leg assembly.

NS: not shown

Appendix A: SUPPORT

Our experienced engineers are available for support and service at all times, 24 hour/7 days a week. They are part of a dynamic organization making sure the entire ADB SAFEGATE is committed to minimal disturbance for airport operations.

ADB SAFEGATE Support

Live Technical Support - Americas

If at any time you have a question or concern about your product, just contact ADB SAFEGATE's technical service department. Trained in all areas of system issues, troubleshooting, quality control and technical assistance, our highly experienced Technical support specialists are available 24 hours a day, seven days a week to provide assistance over the phone.

ADB SAFEGATE **Americas Technical Service & Support (US & Canada): +1-800-545-4157**

ADB SAFEGATE Americas Technical Service & Support (International): +1-614-861-1304

During regular business hours, you can also Chat with a Service Technician. We look forward to working with you!

Before You Call

When you have an airfield lighting or system control system problem it is our goal to support airfield maintenance staff as quickly as possible. To support this effort we ask that you have the following information ready before calling.

- The *airport code*
- If not with an airport, then company name (prefer customer id number)
- Contact phone number and email address
- Product with part number preferable or product number
- Have you reviewed the product's manual and troubleshooting guide
- Do you have a *True RMS* meter available (and any other necessary tools)
- Be located with the product ready to troubleshoot

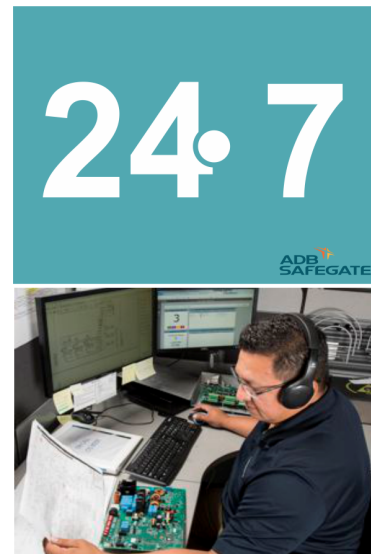

Note

For more information, see www.adbsafegate.com, or contact ADB SAFEGATE Support via email at support@adbsafegate.com or

Brussels: +32 2 722 17 11

Rest of Europe: +46 (0) 40 699 17 40

Americas: +1 614 861 1304. Press 3 for technical service or press 4 for sales support.

China: +86 (10) 8476 0106

A.1 ADB SAFEGATE Website

The ADB SAFEGATE website, www.adbsafegate.com, offers information regarding our airport solutions, products, company, news, links, downloads, references, contacts and more.

A.2 Recycling

A.2.1 Local Authority Recycling

The disposal of ADB SAFEGATE products is to be made at an applicable collection point for the recycling of electrical and electronic equipment. The correct disposal of equipment prevents any potential negative consequences for the environment and human health, which could otherwise be caused by inappropriate waste handling. The recycling of materials helps to conserve natural resources. For more detailed information about recycling of products, contact your local authority city office.

A.2.2 ADB SAFEGATE Recycling

ADB SAFEGATE is fully committed to environmentally-conscious manufacturing with strict monitoring of our own processes as well as supplier components and sub-contractor operations. ADB SAFEGATE offers a recycling program for our products to all customers worldwide, whether or not the products were sold within the EU.

ADB SAFEGATE products and/or specific electrical and electronic component parts which are fully removed/separated from any customer equipment and returned will be accepted for our recycling program.

All items returned must be clearly labeled as follows:

- For *ROHS/WEEE* Recycling
- Sender contact information (Name, Business Address, Phone number).
- Main Unit Serial Number.

ADB SAFEGATE will continue to monitor and update according for any future requirements for *EU directives* as and when *EU member states* implement new *regulations* and or *amendments*. It is our aim to maintain our *compliance plan* and assist our customers.

Company Addresses

ADB SAFEGATE, Belgium	ADB SAFEGATE BV Leuvensesteenweg 585, B-1930 Zaventem Belgium
Contact: Tel.: +32 2 722 17 11 Fax: +32 2 722 17 64	Email: marketing@adbsafegate.com Internet: www.adbsafegate.com
ADB SAFEGATE, Americas	ADB SAFEGATE Americas LLC 977 Gahanna Parkway, Columbus, OH 43230 USA
Contact: Tel.: +1 (614) 861 1304 Fax: +1 (614) 864 2069	Email: sales.us@adbsafegate.com Internet: www.adbsafegate.com
ADB SAFEGATE, Sweden	ADB SAFEGATE Sweden AB Djurhagegatan 19 SE-213 76 Malmö Sweden
Contact: Tel.: +46 (0)40 699 17 00 Fax: +46 (0)40 699 17 30	Email: marketing@adbsafegate.com Internet: www.adbsafegate.com
ADB SAFEGATE, China	ADB SAFEGATE Airfield Technologies Ltd. China Unit 603, D Block, CAMIC International Convention Center, No 3, Hua Jia Di East road, ChaoYang district, Beijing 100102 P.R. China
Contact: Tel.: +86 (10) 8476 0106 Fax: +86 (10) 8476 0090	Email: china@safegate.com Internet: www.adbsafegate.com
ADB SAFEGATE, Germany	ADB SAFEGATE Germany GmbH Konrad-Zuse-Ring 6, D-68163 Mannheim Germany
Contact: Tel.: +49 (621) 87 55 76-0 Fax: +49 (621) 87 55 76-55	Email: marketing@adbsafegate.com Internet: www.adbsafegate.com



Powering Your Airport Performance from Approach to Departure

adbsafegate.com

Copyright © ADB SAFEGATE, all rights reserved

