



Model 6500

Thunderstorm/Lightning Detector

A.0 Disclaimer / Standard Warranty

CE certification

The equipment listed as CE certified means that the product complies with the essential requirements concerning safety and hygiene. The European directives that have been taken into consideration in the design are available on written request to ADB SAFEGATE.

ETL certification

The equipment listed as ETL certified means that the product complies with the essential requirements concerning safety and C22.2 No.180:13 (R2018) regulations. The CSA directives that have been taken into consideration in the design are available on written request to ADB SAFEGATE.

All Products Guarantee

ADB SAFEGATE will correct by repair or replacement per the applicable guarantee below, at its option, equipment or parts which fail because of mechanical, electrical or physical defects, provided that the goods have been properly handled and stored prior to installation, properly installed and properly operated after installation, and provided further that Buyer gives ADB SAFEGATE written notice of such defects after delivery of the goods to Buyer. Refer to the Safety section for more information on Material Handling Precautions and Storage precautions that must be followed.

ADB SAFEGATE reserves the right to examine goods upon which a claim is made. Said goods must be presented in the same condition as when the defect therein was discovered. ADB SAFEGATE further reserves the right to require the return of such goods to establish any claim.

ADB SAFEGATE's obligation under this guarantee is limited to making repair or replacement within a reasonable time after receipt of such written notice and does not include any other costs such as the cost of removal of defective part, installation of repaired product, labor or consequential damages of any kind, the exclusive remedy being to require such new parts to be furnished.

ADB SAFEGATE's liability under no circumstances will exceed the contract price of goods claimed to be defective. Any returns under this guarantee are to be on a transportation charges prepaid basis. For products not manufactured by, but sold by ADB SAFEGATE, warranty is limited to that extended by the original manufacturer. This is ADB SAFEGATE's sole guarantee and warranty with respect to the goods; there are no express warranties or warranties of fitness for any particular purpose or any implied warranties of fitness for any particular purpose or any implied warranties other than those made expressly herein. All such warranties being expressly disclaimed.

Standard Products Guarantee

Products manufactured by ADB SAFEGATE are guaranteed against mechanical, electrical, and physical defects (excluding lamps) which may occur during proper and normal use for a period of two years from the date of ex-works delivery, and are guaranteed to be merchantable and fit for the ordinary purposes for which such products are made.

NOTE



See your applicable sales agreement for a complete warranty description.

Replaced or repaired equipment under warranty falls into the warranty of the original delivery. No new warranty period is started for these replaced or repaired products.

FAA Certified products manufactured by ADB SAFEGATE

ADB SAFEGATE L858 Airfield Guidance Signs are warranted against mechanical and physical defects in design or manufacture for a period of 2 years from date of installation, per FAA AC 150/5345-44 (applicable edition).

ADB SAFEGATE LED products (with the exception of obstruction lighting) are warranted against electrical defects in design or manufacture of the LED or LED specific circuitry for a period of 4 years from date of installation, per FAA EB67 (applicable edition). These FAA certified constant current (series) powered LED products must be installed, interfaced and powered with and through products certified under the FAA Airfield Lighting Equipment Program (ALECP) to be included in this 4 (four) year warranty. This includes, but is not limited to, interface with products such as Base Cans, Isolation Transformers, Connectors, Wiring, and Constant Current Regulators.

Revision History

| Revision | Date | Summary of Changes |
|-----------------|--------------|--|
| E | 2011 Oct 31 | Added 6500-I international model to model options and added description of AC Interface Board and AC voltage settings |
| F | 2015 May 15 | Added 6501 and 6502 Thunderstorm/Lightning Detector models, with note that only the 6500 is FAA-certified for non Fed AWOS in the United States |
| G | 2021 June 30 | Added Model 6500-DC for Direct Connect with 1192 DCP and Model 6500-AC standalone, with note that the 6500-DC is also FAA-certified for non Fed AWOS in the United States, removed Model 6501 and 6502 |
| H | 2025 Apr 1 | ADB SAFEGATE (ECP#ADBSG-0001) |

Contents

| | |
|--|-----------|
| 1. Overview | 5 |
| 1.1 Lightning Detection Antenna | 5 |
| 1.2 Lightning Detection Data Processor | 5 |
| 2. Theory Of Operation | 6 |
| 2.1 Lightning Detection | 6 |
| 2.2 Data Processing | 6 |
| 2.3 Data Reporting | 6 |
| 3. Data Format | 7 |
| 3.1 Sensor Polling | 7 |
| 3.2 Sensor Output Format | 7 |
| 3.2.1 Sensor Mode | 8 |
| 3.2.2 Strike Rate | 8 |
| 3.2.3 Lightning Description | 8 |
| 3.2.4 Lightning Location | 8 |
| 3.2.5 Status Word | 8 |
| 3.2.6 Sensor Status | 9 |
| 3.2.7 Error Codes 3.2.6 Sensor Status | 9 |
| 3.2.8 Sensor Mode | 10 |
| 3.2.9 Noise Triggers | 10 |
| 3.2.10 Strike Test Rate | 10 |
| 3.2.11 Software Version | 10 |
| 3.2.12 Error Flag | 10 |
| 3.2.13 Checksum | 10 |
| 4. Installation & Checkout | 13 |
| 4.1 RFI/EMI Precautions | 13 |
| 4.2 Sensor Installation | 14 |
| 4.3 Checkout | 17 |
| 5. DCP Display Screens | 18 |
| 5.1 Data Screens | 18 |
| 5.1.1 Lightning Sensor Pg. 1 | 18 |
| 5.1.2 Lightning Sensor Pg. 2 | 18 |
| 5.1.3 Lightning Sensor Pg. 3 | 18 |
| 5.1.4 Lightning Sensor Pg. 4 | 19 |
| 5.2 Status Screens | 19 |
| 5.2.1 Lightning Sensor Pg. 5 | 19 |
| 5.2.2 Lightning Sensor Pg. 6 and Pg. 7 | 19 |
| 5.2.3 Lightning Sensor Pg. 8 | 20 |
| 6. Error Messages And Troubleshooting | 21 |
| 6.1 Processor Leds | 24 |
| 7. Maintenance | 25 |

6500 Thunderstorm/Lightning Detector

| | |
|---|-----------|
| 7.1 Periodic Maintenance Schedule | 25 |
| 7.1.1 Monthly Maintenance..... | 25 |
| 7.1.2 Triannual Maintenance | 25 |
| 7.1.3 Annual Maintenance | 25 |
| 7.2 Maintenance Procedures | 25 |
| 7.2.1 Equipment Required..... | 25 |
| 8. Specifications | 26 |
| 9. Warranty | 27 |

1. Overview

The Model 6500 Thunderstorm/Lightning Detector detects electrical discharges associated with thunderstorms within a 200 nautical mile (nm) radius of the system. The Thunderstorm/Lightning Detector is a passive sensor that monitors electromagnetic signals with a receiving antenna. There is no transmitter, and so no harmful transmissions.

The entire package (consisting of an antenna mounted to a 28" × 31" ground plane, and a processor and interface board housed in a NEMA 4X enclosure) mounts simply to a 2½" pipe (2.875" O.D.) using two U-bolts.

Lightning Detection Antenna

The Thunderstorm/Lightning Detector's lightning detection antenna is a combined crossed-loop and sense antenna, which can correlate the electric and magnetic signatures of lightning strikes better than other systems because of its patented sense channel technology. The antenna has been designed to help filter out pulsed noise from sources other than lightning discharges. The antenna detects the electrical and magnetic fields generated by intra-cloud, inter-cloud, or cloud-to-ground electrical discharges, and sends the resulting "discharge signals" to the processor.

Lightning Detection Data Processor

The Thunderstorm/Lightning Detector's lightning detection processor houses the data acquisition circuitry, along with circuitry to process lightning strike data and communicate with the AWOS Data Collection Platform (DCP). Communication with the DCP is via an RS-485 link. The lightning detection processor digitizes, analyzes, and converts the discharge signals into range and bearing data, then stores the data in memory.

The DCP receives data from the Thunderstorm/Lightning Detector every two seconds via an RS-485 link. When polled, the sensor transmits a data package consisting of strike data and status information. When errors are detected, a command can be sent from the DCP requesting a complete error log from the sensor. This error log provides greater detail on the nature and severity of the error.

1.1 Models

The following Thunderstorm/Lightning Detector models are available. Only the Model 6500 and 6500-DC are FAA certified for use with an FAA-certified non-Federal AWOS in the United States.

- The standalone models can be used independently and have their own power supply and communication interface.
- The Direct Connect models are set up to interface only with the Model 1192 DCP. The 6500-DC is powered from the Model 1192 DCP, and the 6500-AC has its own AC power supply.

| Model | Description |
|--------------|--|
| 6500*/6500-I | Standalone with power supply and RS-485 serial interface — reports data when polled |
| 6500-DC* | Direct Connect for use with Model 1192 DCP, RS-422 serial interface, powered from DCP — reports data every 2 seconds |
| 6500-AC | Direct Connect for use with Model 1192 DCP, RS-422 serial interface, separate AC power supply — reports data every 2 seconds |

* Standard for non-Federal AWOS

Table 1 6500 Models

The data consist of distance, direction and status.

The Model 6500-DC and 6500-AC Thunderstorm/Lightning Detectors send data continuously with any particular message string taking less than 2 seconds to send. The distance and direction of strikes are only included if strikes are detected, up to a maximum of 40 strikes every 2 seconds.

1.2 Accessories

The following accessories and replacement parts are available for the Model 6500 Thunderstorm/ Lightning Detector.

| Part Number | Description |
|-------------|--|
| M404802* | AC Interface Board |
| M404806* | Serial Sensor Interface Board |
| M442071* | 10 A 250 V, 5x20 mm slow blow fuse (F1—AC Interface Board) |
| M488606-00 | Stainless steel mounting pole kit for lightning sensors |
| M105655-00 | Deck mounting pole |

* These parts are only used with the Model 6500 Thunderstorm/Lightning Detectors

2. Theory Of Operation

2.1 Lightning Detection

The Model 6500's antenna is a combined crossed-loop and sense antenna, which can correlate the electric and magnetic signatures of lightning strikes better than other systems because of its patented sense channel technology. The antenna has been designed to help filter out pulsed noise from sources other than atmospheric electrical discharges.

The antenna detects the electrical and magnetic fields generated by intra-cloud, inter-cloud, or cloud- to-ground electrical discharges that occur within a 200 nautical mile radius of the antenna, and sends the resulting "discharge signals" to the processor. The processor digitizes, analyzes, and converts the discharge signals into range and bearing data, then stores the data in memory.

2.2 Data Processing

The processor is housed inside the sensor enclosure, and includes data acquisition circuitry and circuitry to process strike data.

The DCP receives data from the lightning sensor either when polled (Model 6500 and 6500-I) or every 2 seconds (Model 6500-DC and 6500-AC) via an RS-422 or RS-485 link. The sensor transmits a data package consisting of strike data and status information. When errors are detected, the errors are recorded in an error log, and the most recent error is displayed on the lightning sensor status screen at the DCP (see Section 5.1.2 and Section 5.2).

2.2.1 Model 6500

The Model 6500 lightning sensor has an Interface Board that provides a data buffer and handles communication with the Data Collection Platform (DCP).

2.2.2 Model 6500-I

The Model 6500-I lightning sensor uses a Model 2715 Universal Power and Communication Module (UPCM) that provides a data buffer and handles communication with the Data Collection Platform (DCP).

2.2.3 Model 6500-DC

The Model 6500-DC lightning sensor connects directly to the Model 1192 DCP, transmitting a data package consisting of strike data and status information every 2 seconds, and is powered from the Model 1192 DCP.

2.2.4 Model 6500-AC

The Model 6500-AC lightning sensor has its own 120/240 VAC power supply, and transmits a data package consisting of strike data and status information every 2 seconds.

2.3 Data Reporting

The Model 6500 detects the presence of a lightning event within 200 nautical miles from the point of installation, and reports any of that activity occurring within a 30 nautical mile radius of the point of installation. The sensor detects and locates thunderstorms and provides the data as part of the standard AWOS message.

1. Range and Direction

Reports thunderstorms/lightning within a 30 nautical mile radius from the installation point. Direction is expressed in compass octants for distances from 10 to 30 nautical miles.

2. Resolution

The location of thunderstorm is reported to within ± 1 nautical mile from actual location of the thunderstorm/lightning detector.

3. Accuracy from Installation Point

Within 10 nautical miles of installation:

Detection: 90% of all thunderstorms

Location: does not exceed 3 nautical miles

Between 10 nautical miles and 30 nautical miles of installation:

Detection: 80% of all thunderstorms

Location: does not exceed 6 nautical miles

4. False Reports

Not more than 2%.

5. Reporting

Updates AWOS information once each minute.

3. Data Format

The Model 6500/6500-I Thunderstorm/Lightning Detectors interface to the DCP via an RS-485 serial link at 4800 bps, eight data bits, no parity, one stop bit.

The Model 6500-DC/6500-AC Thunderstorm/Lightning Detector send data continuously via an RS-422 serial link at 9600 bps, eight data bits, no parity, one stop bit.

3.1 Model 6500 And 6500-I Sensor Polling

The DCP receives data from the Thunderstorm/Lightning Detector every 2 seconds using the DCP poll command shown below.

```
LTNG00\r\n
```

3.1.1 Sensor Output Format

The data received from the Thunderstorm/Lightning Detector are displayed on the DCP's LCD display as they are received. The lightning data shown at the Central Display Platform (CDP) are updated once per minute.

The sensor output is formatted as follows.

```
=s rrrr ts/vsts ltg_dsnt status e crc <CR><LF>
```

The data fields are delimited by 0xFF. The field values should be interpreted as follows

| | |
|----------|---|
| s | Sensor Mode |
| rrrr | The strike rate in counts per minute in normal mode |
| ts/vsts | Lightning Description |
| ltg_dsnt | Lightning Location |
| status | Sensor operational status word |
| E | Error Flag |
| CRC | This provides a checksum value for data validation |
| <CR> | Carriage Return (hexadecimal value 0D) |
| <LF> | Line Feed (hexadecimal value 0A) |

The sample poll response below is a normal poll response when there is no lightning detected by the Thunderstorm/Lightning Detector.

```
=A 0 _ _ SPE00MAG@XRN00000R0000VB1.03 0 042C1
```

The sample poll response shown below is a sample poll response with 102 counts per minute of lightning reported from 5 to 10 nautical miles away in the Northeast, Southeast, South, Southwest, and Northwest quadrants. Table 2. explains each of the fields, which are identified in the poll response and in the table headings using color coding.

```
=A 102 VCTS LTG_DSNT_NE_SE_S_SW_NW SPE00MAG@XRN00000R0000VB1.03 0A380
```

| Sensor Mode | | Strike Rate | LTX Description | | LTX Location | | Status | Error Flag | Checksum |
|-------------|---------|-------------|-----------------|--|---------------|-----------|-----------------|--------------------------------------|------------------------------|
| A | Normal | counts/min | - | None (> 10 miles) | - | None | See Error Codes | Indicates if there has been an error | CRC16 checksum; see Checksum |
| E | If-Test | | TS | Thunderstorm (< 5 n miles) | NE | Northeast | | | |
| | | | VCTS | Very Close Thunderstorm (5–10 n miles) | E | East | | | |
| | | | | | SE | Southeast | | | |
| | | | | | S | South | | | |
| | | | LTG_DSNT | Distant Lightning (10–30 n miles) | SW | Southwest | | | |
| | | | | | W | West | | | |
| | | | | | NW | Northwest | | | |
| | | N | | | North | | | | |
| | | | | ALQDS | All Quadrants | | | | |

Table 2. Sensor Output Field Descriptions

3.1.1.1 Sensor Mode

```
=A 102 VCTS LTG_DSNT_NE_SE_S_SW_NW SPE00MAG@XRN00000R0000VB1.03 0A380
```

For normal sensor operation, the sensor should always be reporting an A for the mode. The sensor should not be operating in any other mode.

3.1.1.2 Strike Rate

```
=A 102 VCTS LTG_DSNT_NE_SE_S_SW_NW SPE00MAG@XRN00000R0000VB1.03 0A380
```

This is the number of lightning strikes detected within the full 200 nautical mile radius of the sensor during the previous one minute. The example shows the sensor reporting 102 lightning strikes during that 1-minute period.

3.1.1.3 Lightning Description

```
=A 0 _ SPE00MAG@XRN00000R0000VB1.03 0 042C1
```

The lightning description indicates the distance of the lightning strikes that have been detected. The underscore “_” is used to show that there were no lightning strikes within 10 miles of the sensor. This is shown in the first example.

If the lightning strikes are within 5 nautical miles of the sensor, TS is indicated in this location of the poll response. This means that there is a thunderstorm at the sensor location.

```
=A 102 VCTS LTG_DSNT_NE_SE_S_SW_NW SPE00MAG@XRN00000R0000VB1.03 0A380
```

If the lightning strikes are from 5 to 10 nautical miles from the sensor, VCTS is indicated in this location of the poll response. This reports that there is a thunderstorm in the vicinity of the LTX sensor. This is demonstrated in the example poll response.

```
=A 102 VCTS LTG_DSNT_NE_SE_S_SW_NW SPE00MAG@XRN00000R0000VB1.03
```

If the lightning strikes are from 10 to 30 nautical miles from the sensor LTG_DSNT is indicated in this location of the poll response. This is showing that there is lightning distant from the sensor, but still detectable as lightning.

3.1.1.4 Lightning Location

```
=A 102 VCTS LTG_DSNT_NE_SE_S_SW_NW SPE00MAG@XRN00000R0000VB1.03
```

This field indicates the location of the detected lightning strikes. The normal cardinal points with their standard abbreviations (N for North, SE for Southeast, etc.) are used in this location of the poll response. If there are lightning strikes detected at multiple directions, they will each be listed with an underscore “_” separating them. The example poll response shows lightning from the Northeast, Southeast, South, Southwest, and Northwest.

3.1.1.5 Status Word

```
=A 102 VCTS LTG_DSNT_NE_SE_S_SW_NW SPE00MAG@XRN00000R0000VB1.03
```

The sensor status is made up of 6 sections. The breakout of the status word is shown below.

SPE00**M**AG@XRN00000**R**0000**V**B1.03

Table 3. explains each of the fields, which are identified in the example and in the table headings using color coding. Also note that each section of the status word is preceded by an indicator letter (**S** for status, **E** for error codes, etc.).

| Status | Error Code | Mode | Config | Heading | Buffer | Reset | Noise Triggers | Strike Test Rate | Software Version |
|---------------------|-----------------|--------------------|-------------|-------------|------------|------------|----------------------------------|-------------------------|-------------------------------|
| P OK | See Error Codes | A Normal Operating | Should be 0 | Should be 1 | Normally X | Normally R | Number of triggers in Noise Mode | Strike Test Mode result | Version of installed software |
| R Recoverable Error | | E Self-Test | | | | | | | |
| F Fatal error | | | | | | | | | |

Table 3. Status Word Fields

3.1.1.6 Sensor Status

```
=A 102 VCTS LTG_DSNT_NE_SE_S_SW_NW SPE00MAG@XRN00000R0000VB1.03 0A380
```

The first value in the status word is the sensor status. The sensor status is preceded by a S. The sensor status value is a P for normal operation. If there has been an error and the sensor recovered from that error, the status is R. If the sensor has had an error that it cannot recover from, the status is F.

3.1.1.7 Error Codes

=A 102 VCTS LTG_DSNT_NE_SE_S_SW_NW SP E00MAG@XRN00000R0000VB1.03 0A380

The error codes are represented by two numerical digits preceded by an E. The following table shows all the error codes with their probable causes.

| Number | Error | Probable Cause |
|--------|---------------------------|---|
| 00 | No Error | Normal Operation |
| 01 | Processor Fault | Main processor |
| 05–08 | Processor Fault | Main processor memory |
| 09–12 | Processor Fault | Digital Signal Processor memory |
| 14, 15 | Processor Fault | Digital Signal Processor |
| 16 | Antenna Fault | Antenna or antenna wiring |
| 17 | Processor Fault | No test strikes, antenna in noisy location, or faulty antenna |
| 18 | Processor Fault | Invalid test strikes, antenna in noisy location, or faulty antenna |
| 19 | Processor Fault | Main Processor or Antenna in noisy location |
| 20 | Configuration Changed | Antenna location (top/bottom, determined by processor wiring) changed since system was last powered up. |
| 21 | Processor Fault | Main processor |
| 22 | Invalid XYZ Input | N/A |
| 23 | Invalid Heading Reference | N/A |
| 24 | MIC Key Stuck | Mic key (inhibit line) has been asserted for at least 60 seconds |
| 25–34 | Processor Fault | Main processor |
| 35 | Processor Fault | Main or Digital Signal Processor |
| 36 | Processor Fault | Main or Digital Signal Processor |
| 40 | Processor Fault | Main processor |
| 41 | Processor Fault | Main or Digital Signal Processor |
| 42 | Processor Fault | Main processor |
| 43 | Invalid request | Poll command was not received properly |
| 44–49 | Serial Communication | General communication errors including wrong baud rate, excessive noise, etc. |

Table 3. Error Codes and Probable Causes

3.1.1.8 Sensor Mode

```
=A 102 VCTS LTG_DSNT_NE_SE_S_SW_NW SPE00MAG@XRN00000R0000VB1.03 0A380
```

The sensor mode is preceded by an M. There are five parts to the sensor mode section of the status word. The first digit represents the sensor mode. This should always be an A for normal operation. The test mode is not used.

The second digit is the sensor configuration. This should always be a G. The third digit is the sensor heading flag. This should always be 1. The fourth digit is the buffer flag. This is a B if the buffer has been cleared and an X if the clear message has not been received. The fifth digit is the reset flag. This can either be an X or a R.

3.1.1.9 Noise Triggers

```
=A 102 VCTS LTG_DSNT_NE_SE_S_SW_NW SPE00MAG@XRN00000R0000VB1.03 0A380
```

The noise trigger count is preceded by an N. The noise trigger section of the status word is for the number of triggers detected when noise mode is on. This is a five digit number that should always be 00000 while the sensor is in normal operation.

3.1.1.10 Strike Test Rate

```
=A 102 VCTS LTG_DSNT_NE_SE_S_SW_NW SPE00MAG@XRN00000R0000VB1.03 0A380
```

The strike test rate is preceded by an R. The four digit number in the strike test rate section of the status word is the number of strikes detected per minute while the sensor is in the Strike Test mode. While the sensor is in normal operation, this should be 0000.

3.1.1.11 Software Version

```
=A 102 VCTS LTG_DSNT_NE_SE_S_SW_NW SPE00MAG@XRN00000R0000VB1.03 0A380
```

The software version of the sensor is preceded by a V. In the example shown the software version is B1.03. There are two separate software programs in the sensor. The second is in the serial interface board inside the sensor. The second software version is not displayed in the poll response.

3.1.1.12 Error Flag

```
=A 102 VCTS LTG_DSNT_NE_SE_S_SW_NW SPE00MAG@XRN00000R0000VB1.03 0A380
```

This is only a status indicator that there was an error. This will normally be a 0. Any other character than a 0 indicates that an error has occurred. Refer to the error section of the status word for the actual error that occurred.

3.1.1.13 Checksum

```
=A 102 VCTS LTG_DSNT_NE_SE_S_SW_NW SPE00MAG@XRN00000R0000VB1.03 0A380
```

The last four text digits of the poll response is the checksum of the poll response. This allows the polling computer to verify that the data message was received properly. The checksum is calculated using the CRC16 method. A sample C program for calculating this CRC is shown below.

6500 Thunderstorm/Lightning Detector

```
/******
```

CRC routine

```
USE:  crc = crc16(buffer, length, initial_value)
```

```
where:  crc is the returned value,
        buffer is the data buffer to compute a crc
        length is the number of bytes in buffer to process
        initial_value is the results of previous crc calculations
        that will allow the buffer crc to be computed in
        stages if necessary. If this is not necessary,
        then set initial_value to 0.
```

```
*****/
```

```
unsigned int crc16(char *string, unsigned int length, unsigned int ival)
```

```
/* buffer address to compute a crc */
/* number of characters to process */
/* initial value of crc          */
```

```
{
    static unsigned int crc;

    /*   CRC values for crc16 routine           */

    static unsigned int    crc_vals[] =
    {
        0x0000,0xc0c1,0xc181,0x0140,0xc301,0x03c0,0x0280,0xc241,
        0xc601,0x06c0,0x0780,0xc741,0x0500,0xc5c1,0xc481,0x0440,
        0xcc01,0x0cc0,0x0d80,0xcd41,0x0f00,0xcfc1,0xce81,0x0e40,
        0x0a00,0xcac1,0xcb81,0x0b40,0xc901,0x09c0,0x0880,0xc841,
        0xd801,0x18c0,0x1980,0xd941,0x1b00,0xdbc1,0xda81,0x1a40,
        0x1e00,0xdec1,0xdf81,0x1f40,0xdd01,0x1dc0,0x1c80,0xdc41,
        0x1400,0xd4c1,0xd581,0x1540,0xd701,0x17c0,0x1680,0xd641,
        0xd201,0x12c0,0x1380,0xd341,0x1100,0xd1c1,0xd081,0x1040,
        0xf001,0x30c0,0x3180,0xf141,0x3300,0xf3c1,0xf281,0x3240,
        0x3600,0xf6c1,0xf781,0x3740,0xf501,0x35c0,0x3480,0xf441,
        0x3c00,0xfcc1,0xfd81,0x3d40,0xff01,0x3fc0,0x3e80,0xfe41,
        0xfa01,0x3ac0,0x3b80,0xfb41,0x3900,0xf9c1,0xf881,0x3840,
        0x2800,0xe8c1,0xe981,0x2940,0xeb01,0x2bc0,0x2a80,0xea41,
        0xee01,0x2ec0,0x2f80,0xef41,0x2d00,0xedc1,0xec81,0x2c40,
        0xe401,0x24c0,0x2580,0xe541,0x2700,0xe7c1,0xe681,0x2640,
        0xa001,0x60c0,0x6180,0xa141,0x6300,0xa3c1,0xa281,0x6240,
        0x6600,0xa6c1,0xa781,0x6740,0xa501,0x65c0,0x6480,0xa441,
        0x6c00,0xacc1,0xad81,0x6d40,0xaf01,0x6fc0,0x6e80,0xae41,
        0xaa01,0x6ac0,0x6b80,0xab41,0x6900,0xa9c1,0xa881,0x6840,
        0x7800,0xb8c1,0xb981,0x7940,0xbb01,0x7bc0,0x7a80,0xba41,
        0xbe01,0x7ec0,0x7f80,0xbf41,0x7d00,0xbdc1,0xbc81,0x7c40,
        0xb401,0x74c0,0x7580,0xb541,0x7700,0xb7c1,0xb681,0x7640,
        0x7200,0xb2c1,0xb381,0x7340,0xb101,0x71c0,0x7080,0xb041,
        0x5000,0x90c1,0x9181,0x5140,0x9301,0x53c0,0x5280,0x9241,
        0x9601,0x56c0,0x5780,0x9741,0x5500,0x95c1,0x9481,0x5440,
        0x9c01,0x5cc0,0x5d80,0x9d41,0x5f00,0x9fc1,0x9e81,0x5e40,
        0x5a00,0x9ac1,0x9b81,0x5b40,0x9901,0x59c0,0x5880,0x9841,
```

6500 Thunderstorm/Lightning Detector

```
    0x8801,0x48c0,0x4980,0x8941,0x4b00,0x8bc1,0x8a81,0x4a40,  
    0x4e00,0x8ec1,0x8f81,0x4f40,0x8d01,0x4dc0,0x4c80,0x8c41,  
    0x4400,0x84c1,0x8581,0x4540,0x8701,0x47c0,0x4680,0x8641,  
    0x8201,0x42c0,0x4380,0x8341,0x4100,0x81c1,0x8081,0x4040};  
  
    crc = ival;  
    while(length--)  
        crc = crc_vals[(*string++ ^ crc) & 0xff] ^  
            ((crc >> 8) & 0xff);  
    return crc;  
}  
  
/* end crc16 routine */
```

3.2 Model 6500-DC And 6500-AC Sensor Data

The Model 6500-DC and 6500-AC Thunderstorm/Lightning Detectors send data continuously with any particular message string taking less than 2 seconds to send.

3.2.1 Sensor Output Format

The data from the Model 6500-DC and 6500-AC Thunderstorm/Lightning Detectors are sent continuously and may be logged or displayed. For example, ADB SAFEGATE offers a special MetObserver software version (P/N M595191-00) that allows the lightning bearing and range data to be displayed using the Central Data Processor.

The Model 6500-DC and 6500-AC Thunderstorm/Lightning Detectors are designed to be connected to the Model 1192 DCP, which provides power to the 6500-DC and aggregates the data that are then sent to a Central Data Platform for processing and display.

The sensor output is formatted as follows.

<STX> <id > <ddd> <CR> (<id> <ddd> <CR>) . <cc > <ETX>

STX ASCII start-of-text character (02h)

id item designator from the table below

ddd value of the data item in the Item Format column in the table below

CR Carriage Return

Cc checksum = summing all data between STX and ";, then masking all but the lower 8 bits

ETX ASCII end-of-text character (03h)

| Item Designator | Item Format | Field Width (bytes) | Item Description | | | | | | | | | | | | | | | | | |
|-----------------|------------------|---------------------|--|------|----------------|-----------------|--------|------|----|------------------|---|---|---|---|----|------------------|---|---|---|---|
| %l | dmch | 4 | <p>System Status, where d is "F" = fatal fault, "R" = recoverable fault, "P" = O.K. Display Mode m is transmitted as follows:</p> <ul style="list-style-type: none"> "A" Weather "B" Noise Monitor "C" Strike Test "D" Demo "E" Pilot Initiated Self-Test <p>Configuration data c is sent as 010:B4:B3:B2:B1:B0 where</p> <table border="0"> <tr> <td></td> <td>Heading_Config</td> <td>Synchro Stepper</td> <td>Serial</td> <td>None</td> </tr> <tr> <td>B4</td> <td>HdgFormat1_Input</td> <td>1</td> <td>0</td> <td>1</td> <td>0</td> </tr> <tr> <td>B3</td> <td>HdgFormat2_Input</td> <td>0</td> <td>1</td> <td>1</td> <td>0</td> </tr> </table> <p>B2 Heading Flag Input Sense; 0 if a High level signal on Heading Flag+ (pin P2-24) with respect to Heading Flag- (pin P2-25) indicates Valid Heading</p> <p>B1 Antenna. Mount 0=Bottom, 1=Top</p> <p>B0 Spare</p> <p>Heading Flag h is sent as 010:B4:B3:B2:B1 ;B0 where</p> <ul style="list-style-type: none"> B4 Heading Stabilization 1=Enabled B3 Heading Flag Input 1=Valid B2 Heading Valid 1=Valid B1 Synchro Reference Flag 1=Valid B0 Synchro Angle Flag 1=Valid | | Heading_Config | Synchro Stepper | Serial | None | B4 | HdgFormat1_Input | 1 | 0 | 1 | 0 | B3 | HdgFormat2_Input | 0 | 1 | 1 | 0 |
| | Heading_Config | Synchro Stepper | Serial | None | | | | | | | | | | | | | | | | |
| B4 | HdgFormat1_Input | 1 | 0 | 1 | 0 | | | | | | | | | | | | | | | |
| B3 | HdgFormat2_Input | 0 | 1 | 1 | 0 | | | | | | | | | | | | | | | |
| | | | <p>Heading Stabilization state defaults to last state when powered up. Synchro Reference Flag and Synchro Angle Flag will be zero when configured for Stepper or Serial heading input. Transmitted once per message.</p> | | | | | | | | | | | | | | | | | |

| Item Designator | Item Format | Field Width (bytes) | Item Description |
|-----------------|---------------------------------|---------------------|--|
| %S | cccbbrrr | 9 | ccc=Range to strike ("001" - "200" NM) Cell mode (a value of 201 indicates invalid); bbb=Bearing to strike, clockwise in degrees "000" - "359" deg). rrr=Range to strike ("001" - "200" NM) Strike mode. This Item Designator may appear from 0 to 40 times per message depending on thunderstorm activity. Invalid Cell mode range indicates the strike is not displayed in Cell mode view. In Noise Monitor Mode, ccc will always indicate 201 and rrr will have a range of 001 - 400. |
| %A | rrrbbb | 6 | Test strike range and bearing. rrr=Range to strike ("001" - "200" NM); bbb=Bearing to strike, degrees clockwise("000" - "359" deg). Transmitted once per message block. Only transmitted when in Strike Test Mode. |
| %E | dd | 2 | Fault code ("00" - "99"), more than one possible (%E for each code up to 5 codes), see Table 4. Transmitted each message only when System Status (%I) indicates fault or degraded operation. |
| %V | Xxxxxx | 6 | X="B", xxxxx=S/W version string, padded on right with "spaces" if needed. Transmitted at least 2 times per minute. |
| %T | dddd | 5 | dddd="00000" - "99999", number of triggers detected since power on. Pressing "Clear" resets counter to "00000". Used for installation verification and troubleshooting. |
| %B | | 0 | Clear message indicates that the data buffers are cleared. |
| %H | dddd | 4 | Aircraft heading x10 (0000 - 3599). Heading outside valid range indicates heading not available or "flagged" (e.g., 9999). When configured for Stepper heading, this message contains relative heading angle. |
| %D | 14 lines (24 columns +CR) | 350 | System Data Screen text requested by the host. The System data is sent in addition to the standard communications block prefixed by its own STX and followed by its own ETX. The System data screens may contain software versions, environmental parameters or the fault log. One of the System Data Screens is transmitted in response to a System Data Screen request. |
| %L | emmtbbb | variable | BFG Logo - generally requested only once during the power up sequence for display. The logo is a bitmap image of the BFG logo. e=Encoding type character (always "1"), mm=Msg number, tt=Total messages, bbb=Number of bytes of logo data in message, *=bbb bytes of logo. |

A message is sent from the sensor once every two seconds. Each message includes at least the sensor orientation and status. If strikes are detected, they are shown between the orientation data and the status data. Up to 40 strikes may be included in a single two-second message. If errors are detected, they will be included in the message as well.

Below is a sample of the sensor output data stream that includes a description of the data immediately following the data.

6500 Thunderstorm/Lightning Detector

%VB1.03 (Software Version, sent at least twice per minute)

%IPAG@ (Status = OK, Weather Mode)

----- 2 seconds -----

%H0000 (Sensor Orientation 0 - North)

%IPAG@ (Status = OK, Weather Mode)

----- 2 seconds -----

%H0000 (Sensor Orientation 0 - North)

%S026276026 (Lightning Strike = 26NM, 276 degrees)

%S026278026 (Lightning Strike = 26NM, 278 degrees)

%S027277027 (Lightning Strike = 27NM, 277 degrees)

%S025279025 (Lightning Strike = 25NM, 279 degrees)

%S027279027 (Lightning Strike = 27NM, 279 degrees)

%S201279031 (Invalid Lightning Strike = 31NM, 279 degrees; "201" indicates an invalid strike)

%IPAG@ (Status = OK, Weather Mode)

----- 2 seconds -----

%E16 (Error 16 – Antenna Fault)

4. Installation & Checkout

NOTE

Installation and checkout of the Model 6500 Thunderstorm/ Lightning Detector may only be performed by qualified personnel trained in the theory of operation of the Model 6500 Thunderstorm/Lightning Detector, site preparation requirements, maintenance theory of the Automated Weather Observing System (AWOS), and interface and operation functions of the AWOS Data Collection Platform.

The Thunderstorm/Lightning Detector package (consisting of an antenna mounted to a 28" x 32" ground plane and a processor housed in a NEMA 4X enclosure) mounts to a 2½" pipe (2.875" O.D.) using two U-bolts. A section of 2.5" (64 mm) I.D. standard galvanized steel pipe can be used as a mast with no drawbacks or special adaptation. Refer to the site preparation instructions and applicable drawings for foundation, grounding, conduit, and junction box installation details.

**CAUTION**

The Thunderstorm/Lightning Detector's ground plane extends well beyond the edges of the sensor enclosure. Be aware of this hazard when working around the sensor.

4.1 RFI/EMI Precautions

The Model 6500 Thunderstorm/ Lightning Detector's antenna is sensitive to static charges, so care must be taken to ensure that the antenna and ground plane are as far removed as possible from composite materials (e.g., plastic materials or fiberglass), since these materials have a tendency to build up a static charge. The sky immediately above the antenna must be unobstructed.

The sensor should be mounted as far as possible from devices that emit high levels of radio-frequency interference (RFI) and electromagnetic interference (EMI), such as VHF and UHF radios, RF modems, fluorescent lamps, and ballasts, air conditioner and heater blowers, as well as any current-carrying cables. Pay attention to these general clearance guidelines.

- Strobe lamps and power supplies — 5 ft. (1.5 m)
- Fluorescent lamps and ballasts — 5 ft. (1.5 m)
- Air conditioners and heater blowers — 5 ft. (1.5 m)
- Telephone antennas — 4 ft. (1.2 m)
- VHF/UHF communication antennas — 1 ft. (0.3 m)
- Any current-carrying cable — 2 ft. (0.6 m)

In addition to the above restrictions, certain site installations may have to be scrutinized more care- fully from an RFI/EMI perspective. Finding locations to mount the ground plane and antenna that will minimize interference from RFI/EMI sources can be enhanced by the use of standard RFI measuring equipment. The recommended equipment for monitoring the proposed installation area is a typical spectrum analyzer with a broadband conical antenna. The spectrum analyzer should be set up to scan the frequencies of concern (100-500 MHz) for the typical VHF and UHF radio links near the installation. Once it has been determined that there is significant interference, it is imperative that the lightning sensor be moved to a location as far from the interfering device as possible. *Under no circumstances should the lightning sensor antenna and ground plane be placed within one foot of either a VHF or UHF transmitting antenna.*

4.2 Sensor Installation

After installing the mast, conduit, and junction box, follow the instructions below for assembling and installing the sensor.

1. If the signal and power cables have not already been installed between the signal and power distribution boxes and the sensor pad, pull the required lengths of cable through conduit to the junction boxes at the sensor pad.
2. (See Figure 1.). The mounting bracket attaches to the underside of the 6500 enclosure with four bolts. Position the bracket against the underside of the enclosure so that the mounting holes in the bracket and enclosure align.

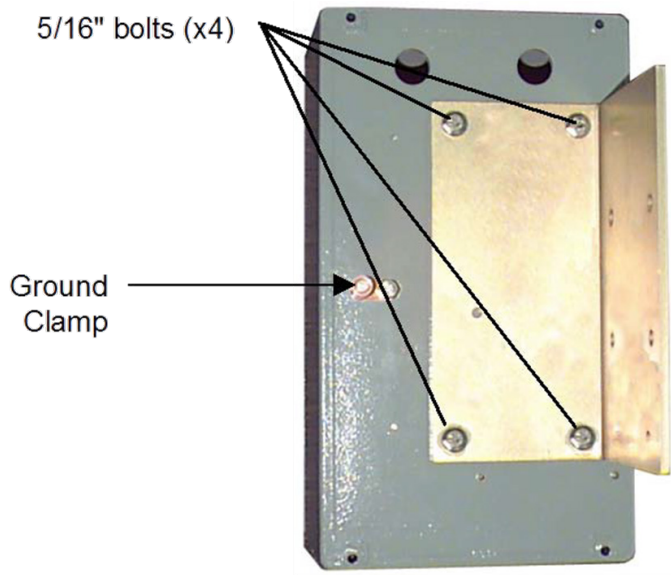

Figure 1. Mounting Bracket Installation

3. Apply RTV 162 to the threads of the four 5/16" hex mounting bolts.
4. Fasten the bracket to the enclosure with the four 5/16" hex bolts, flat washers, and lock washers.
5. Tighten the bolts.
6. Set the sensor package (antenna, ground plane, enclosure, and bracket) on the mast, and fasten loosely with two U-bolts, lock washers, and flat washers as shown in Figure 2.

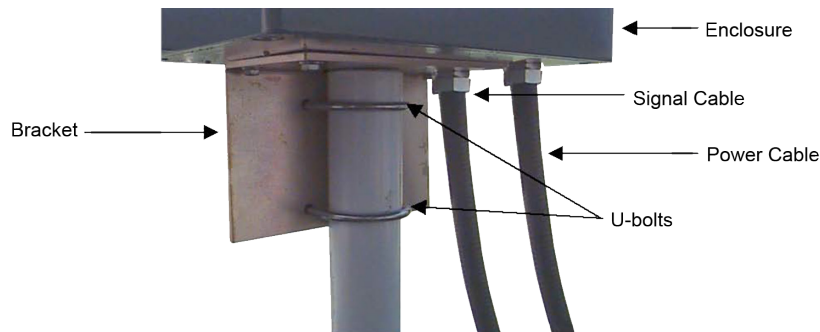

Figure 2. Sensor Package Mounting

The power cable shown above is not used with the Model 6500-DC Thunderstorm/Lightning Detector where the low-voltage DC line shares the conduit with the signal line.

7. Align the antenna to magnetic north by holding a straightedge compass against the ground plane (with the compass's North index oriented in the same direction as the N on the ground plane) and turning the entire sensor package until the compass indicates North.
8. Tighten the two U-bolts.
9. Open the sensor enclosure by loosening the four countersunk bolts shown in Figure 3. Do not remove the six bolts holding the ground plane to the enclosure lid.

6500 Thunderstorm/Lightning Detector

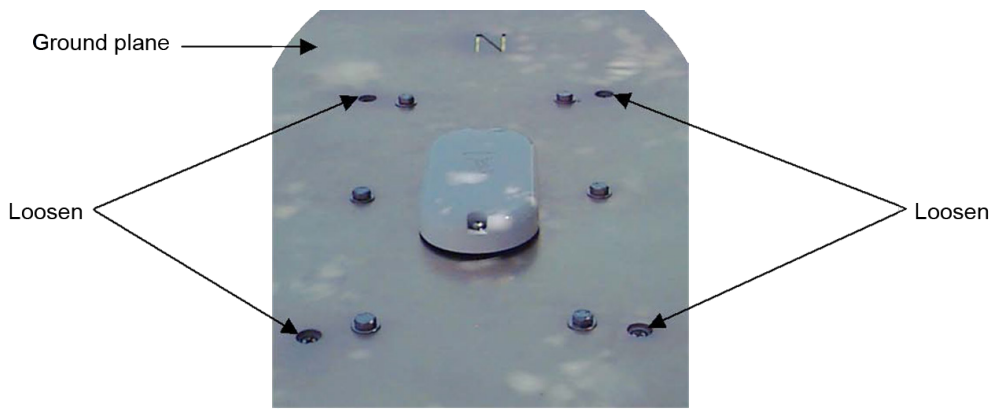

Figure 3. Opening the Sensor Enclosure

10. The sensor enclosure lid is equipped with hinged bolts (see Figure 4) to allow the box to be opened with the ground plane attached. Grasp both sides of the ground plane and lift straight up as far as possible (about 3”), then tilt the ground plane and lid over carefully to gain access to the enclosure interior. When fully open, the ground plane will rest against the side of the enclosure.



Figure 4. Enclosure Hinges

11. Route the signal and power cables from their junction boxes through flex conduit to the sensor.
12. Fasten a ground wire between the ground cable installed during site preparation and the ground clamp on the underside of the enclosure (see Figure 1).

4.2.1 Model 6500

4.2.1.1 AC Interface Board

The AC Interface Board is only used with the Model 6500 Thunderstorm/Lightning Detector.

Two fuses are located on the AC Interface Board (see Figure 5). Though always installed, fuse F2 is not needed. Replace the fuses only with fuses of the same rating, as shown below. The AC supply voltage is set with switch S2.

- | | |
|----|---|
| F1 | 10 A 250 V, 5×20 mm slow blow |
| F2 | 5 A 250 V, 5×20 mm slow blow (not needed) |

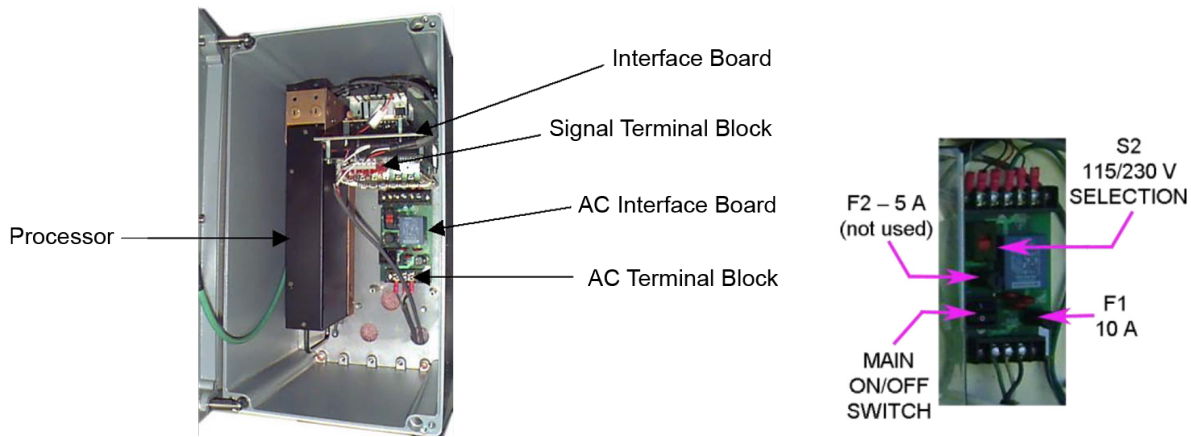

Figure 5. AC Interface Board



NOTE

Note that there is a plastic safety shield over the AC Interface Board. This shield must be removed to access the fuses for replacement and should be reinstalled once the fuse has been replaced.

4.2.1.2 Summary of Signal and Power Wiring Connections

1. Connect the signal wires to the interface board inside the enclosure (Figure 5) according to Table 5.
2. Connect the incoming AC power wires to the AC interface board inside the enclosure (Figure 5) according to Table 5.
3. Close the enclosure lid and tighten the four countersunk bolts.

6500 Thunderstorm/Lightning Detector

| Interface Board TB1 Pin | Function | Color | DCP TB4 |
|-------------------------|-----------|-------|---------|
| 4 | RS485 (+) | WHITE | 1 |
| 5 | RS485 (-) | BLACK | 2 |
| 6 | GROUND | RED | 7 |

| AC Interface Board TB1 Pin | Function | Color |
|----------------------------|----------|-------|
| 1 | HOT | BLACK |
| 2 | NEUTRAL | WHITE |
| 3 | GROUND | GREEN |

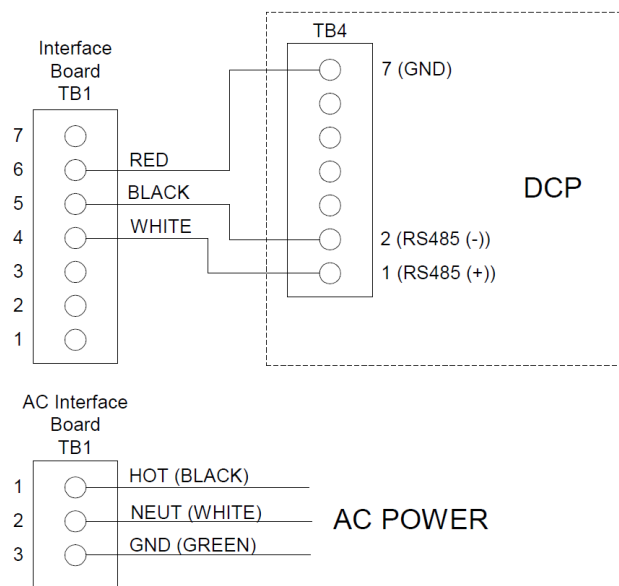

Table 5. Model 6500 Signal and Power Wiring

4.2.2 Model 6500-I

The Model 6500-I Thunderstorm/Lightning Detector interfaces with power and signals through the Model 2715 Universal Power and Communication Module (UPCM).

1. Connect the signal wires to the interface board inside the enclosure (Figure 5) according to Table 6.
2. Connect the incoming AC power wires to the AC interface board inside the enclosure (Figure 5) according to Table 6.
3. Close the enclosure lid and tighten the four countersunk bolts.

| Serial Output 2 Pin | Function | Color |
|---------------------|------------|---|
| 3 | RS485 D- | Any colors may be used as long as they match the signals on each end of the connection. |
| 4 | RS485 D+ | |
| 5 | SIGNAL GND | |
| DC Power Pin | Function | Color |
| 1 | DCOUT + | RED |
| 2 | DCOUT - | BLACK |
| AC Line Input | Function | Color |
| 1 | HOT | BLACK |
| 2 | NEUTRAL | WHITE |
| 3 | GROUND | GREEN |

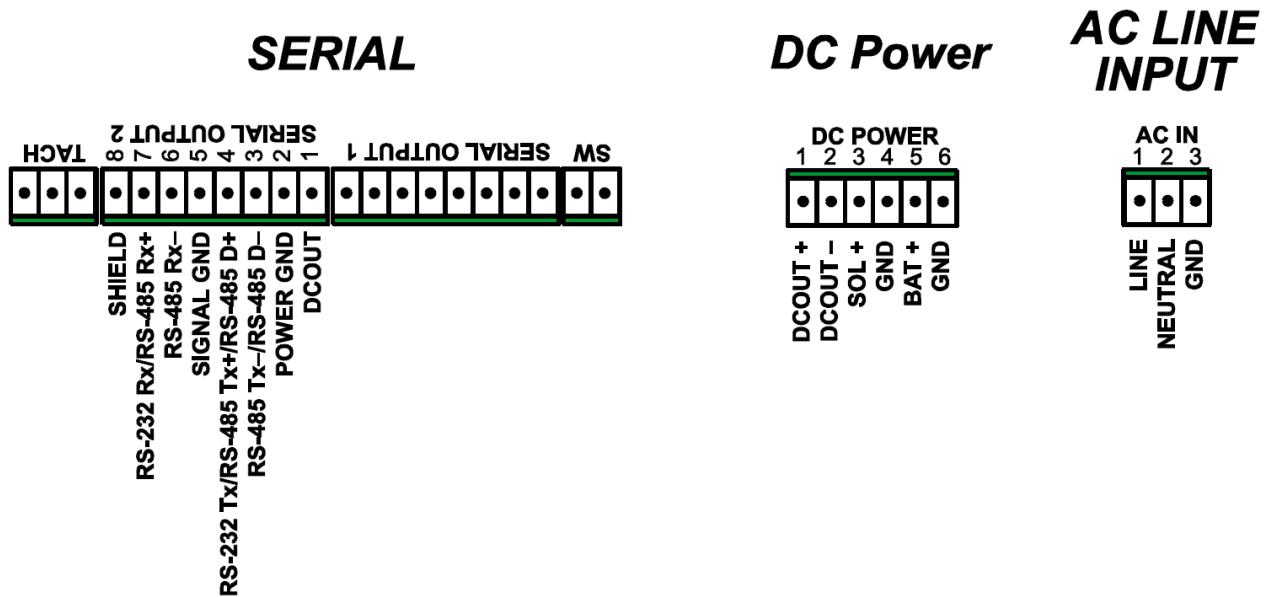

Table 6. Model 6500-I Signal and Power Wiring

4.2.3 Model 6500-DC

The Model 6500-DC Thunderstorm/Lightning Detector was designed for Direct Connection to the Model 1192 DCP.

1. Connect the power and signal wires to the terminal blocks inside the enclosure according to Figure 6.
2. Close the enclosure lid and tighten the four countersunk bolts.

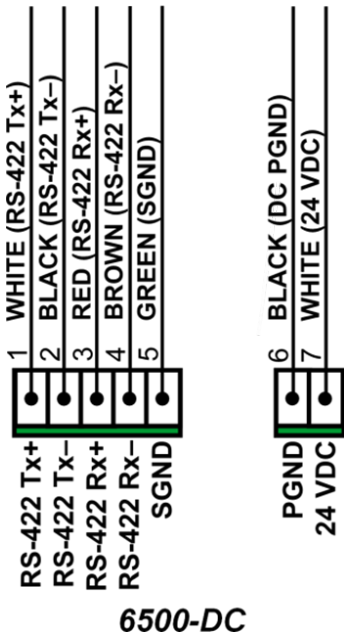

Figure 6. Summary of Model 6500-DC Connections

Run the power and signal lines through the flex conduit to the Model 1192 DCP and connect the lines as shown in Figure 7.

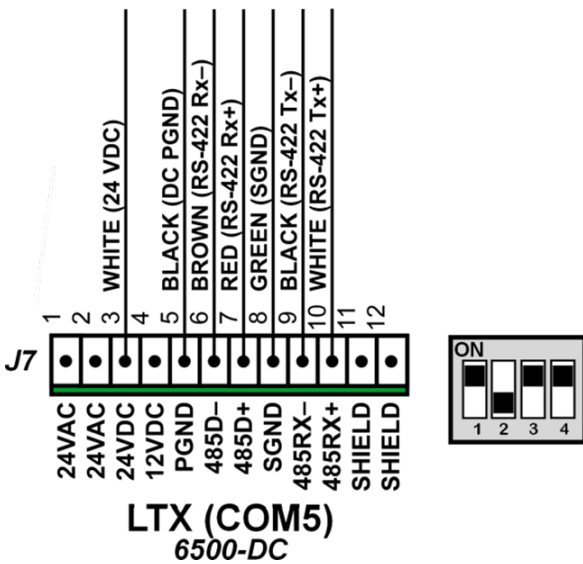

Figure 7. Model 6500-DC Connections to Model 1192 DCP

4.2.4 Model 6500-AC

The Model 6500-AC Thunderstorm/Lightning Detector is a standalone sensor that is powered from a 120/240 VAC connection.

1. Connect the power and signal wires to the terminal blocks inside the enclosure according to Figure 8.
2. Close the enclosure lid and tighten the four countersunk bolts.

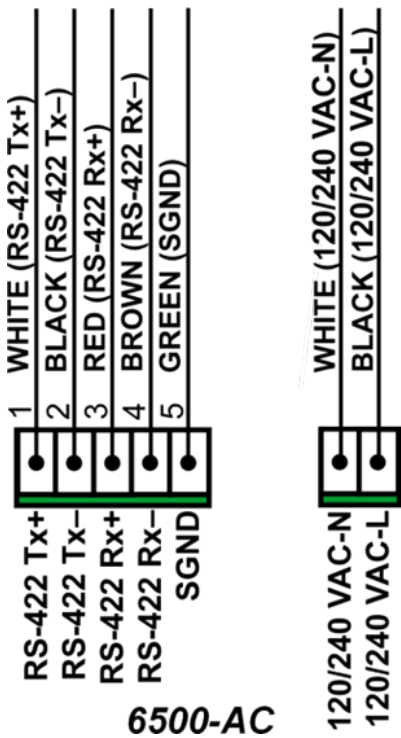

Figure 8. Summary of Model 6500-AC Connections

4.3 Checkout

To verify the sensor is working properly, power the sensor and DCP up and verify that, after one minute of operation, data is reported from the sensor. *(Bear in mind that, in the absence of lightning in the measuring area, the data screens will report no strikes.)* Check the status screens (described in the next section) and verify that no errors are reported.

5. DCP Display Screens

The lightning data generated by the Model 6500 series of Thunderstorm/Lightning Detectors connected to a DCP is available for viewing on the DCP LCD display screens. These data are updated once per minute, and are shown on the display screens.

5.1 Model 1190/1190-I/1191-I DCP Screens

To view the data and status screens, scroll to the first lightning data screen using the * and # keys on the keypad as explained in the **DCP User's Manual** (to move down (to a higher numbered screen), press the # key. To move up (to a lower numbered screen), press the * key). The contents of the screens are explained below.

If the sensor is not working, offline, or not communicating with the DCP, the message "Sensor Not Reporting" will be displayed on the first five screens (Pages 1-5), and "MMMMMMMMMMMMMMMM" will be shown on the following two screens (Pages 6 and 7).

5.1.1 Data Screens

Four consecutive data screens immediately following the ADC Vref screen report lightning data. The first three screens show strikes detected within different distance ranges (<10 nautical miles, 10-20 nautical miles, and >20 nautical miles). When a strike is detected, the data screens will show the direction of the strike by octant (N, S, NW, SE, etc.). When strikes are detected in several directions, they will all be shown, separated from one another by underscores. The fourth data screen shows the strike rate in number of strikes per minute.

5.1.1.1 Lightning Sensor Pg. 1

The first data screen reports any detected lightning strikes within 10 nautical miles of the installation site.

If the strikes are within 0-5 nautical miles, the direction will be preceded by "TS" (thunderstorm). This will be voiced in the AWOS voice output as "Thunderstorm at the airport."

If the strikes are within 5-10 nautical miles, the direction will be preceded by "VCTS" (very close thunderstorm). This will be voiced in the AWOS voice output as "Thunderstorm in the vicinity."

If no strikes are detected, the message "No Strikes < 10 mi" will be displayed.

This screen is updated every minute.

| | | |
|-------------|--------|-----|
| Lightning | Sensor | Pg1 |
| VCTS_E_SE_S | | |

This example indicates strikes have been detected between 5-10 nautical miles of the installation site to the East, Southeast, and South.

5.1.1.2 Lightning Sensor Pg. 2

The second data screen reports any detected lightning strikes between 10-30 nautical miles of the installation site. This will be voiced in the AWOS voice output as "Lightning distant," followed by the direction of the strikes.

If no strikes are detected, the message "No Strikes > 10 mi" will be displayed.

If the data string exceeds the LCD's capacity (20 characters), the data will be continued on the next screen (**Lightning Sensor Pg. 3**).

This screen is updated every minute.

| | | |
|------------|--------|-----|
| Lightning | Sensor | Pg2 |
| LTG_DSNT_S | | |

This example indicates strikes have been detected between 10-30 miles of the installation site to the South.

5.1.1.3 Lightning Sensor Pg. 3

The third data screen displays data continued from the previous screen when the amount of data for the 10-30 mile range exceeds the LCD's 20-character capacity. If the data does not exceed 20 characters, this screen is a duplicate of **Lightning Sensor Pg. 2**.

| | | |
|------------|--------|-----|
| Lightning | Sensor | Pg3 |
| LTG_DSNT_S | | |

This example shows the same data as the preceding screen, since the current data for the 10-30 mile range does not exceed the

LCD's capacity.

5.1.1.4 Lightning Sensor Pg. 4

The fourth data screen reports the number of strikes detected within the full measuring area (200 nautical mile radius of the installation site) during the previous one minute. The value is reported in strikes per minute.

If no strikes were detected, the message "Strike Rate none" will be displayed.

This screen is updated every minute.

| | | |
|--------------------|--------|-----|
| Lightning | Sensor | Pg4 |
| Strike Rate 15/min | | |

This example indicates 15 lightning strikes were detected within the measuring area during the previous minute.

5.1.2 Status Screens

Four status screens follow the four lightning data screens. The first status screen shows the sensor's current operating mode. The next two screens display the two most recent errors detected by the sensor's self-tests. The final screen shows CRC errors and timeouts detected since power-up.

5.1.2.1 Lightning Sensor Pg. 5

This screen shows the current operating mode of the sensor. This should always read "Normal Weather Data", unless the sensor fails or is disconnected, in which case it will read "Sensor Not Reporting".

| | | |
|---------------------|--------|-----|
| Lightning | Sensor | Pg5 |
| Normal Weather Data | | |

5.1.2.2 Lightning Sensor Pg. 6 and Pg. 7

These two screens show the most recent status message received from the lightning sensor. The format of the status message is explained in Table 2, and the error codes (indicated by the two-digit number immediately following "E") are listed in Table 7. Due to the length of the message, it is split between two screens.

| | | |
|-------------------|--------|-----|
| Lightning | Sensor | Pg6 |
| SPE00MAG@XXN00000 | | |

| | | |
|-------------|--------|-----|
| Lightning | Sensor | Pg7 |
| R0000VB1.03 | | |

The example shown above is decoded as follows.

| | |
|---------------|--|
| SP | Sensor status=OK |
| E00 | No errors |
| MA | Normal Weather Data mode |
| G | Configuration=normal |
| @ | Heading flag=normal |
| XX | No clear message received from CDP; no reset |
| N00000 | Noise mode OFF |
| R0000 | Strike test mode OFF |
| VB1.03 | Software version B1.03 |

5.1.2.3 Lightning Sensor Pg. 8

The final lightning sensor status screen shows the number of CRC errors and timeouts detected since the sensor was powered up.

| | | |
|--------|-----|-----------|
| LTNG00 | CRC | Err/Touts |
| 0/0 | | |

The above example shows that no CRC errors and no timeouts have been recorded since the sensor was last powered up

5.2 Model 1192 DCP Screens

The Lightning screens display the processed sensor data (LTX information), the sensor status, and the raw sensor data (LTX string). The specific sensor is identified at the bottom of the screen.

| LTX Information | |
|----------------------|---------|
| LTX at Airport or VC | |
| No Strikes | < 10 mi |
| LTX Distant | |
| No Strikes | > 10 mi |
| 6500 | |

| LTX Strike Rate | |
|--------------------|--|
| Strike Rate 15/min | |
| 6500 | |

| LTX Status | |
|---------------------|---|
| Normal Weather Data | |
| SPE00MA01XXN0000R00 | |
| 00 - No Faults | |
| Data Errors: | 0 |
| 6500 | |

| LTX String | |
|----------------------|--|
| A>0>_>_>APE00MA01 | |
| XXNN0000R0000VB1.234 | |
| >0>0>DF0D | |
| 6500 | |

6. Error Messages And Troubleshooting

The Model 6500 series of Thunderstorm/Lightning Detector continuously runs a series of self-tests to check sensor operation and return error messages when a fault is detected. When connected to a DCP, the most recent status message is displayed on status screens viewable at the DCP as explained in Chapter 5. Any detected errors are identified by “E” and a two-digit number (“E00” during normal operation) on the first status screen. Table 7 lists all the possible error codes, along with the probable cause of the fault and possible corrective action. In many cases, a persistent error will require returning the sensor to ADB SAFEGATE for service.

For monitoring communications between the DCP and the sensor, a status screen (**Lightning Sensor Pg. 8** or the LTX Status screen) displays a record of communications errors since the sensor was powered up.

| Error | Probable Cause | Corrective Action |
|----------------------------|---|--|
| ERROR 00: No Error | — | |
| ERROR 01. Processor Fault. | Main processor | Continued operation is not possible. Contact Field Service. |
| ERROR 05. Processor Fault. | Main processor memory | Continued operation is not possible. Contact Field Service. |
| ERROR 06. Processor Fault. | Main processor memory | Continued operation is not possible. Contact Field Service. |
| ERROR 07. Processor Fault. | Main processor memory | Continued operation is not possible. Contact Field Service. |
| ERROR 08. Processor Fault. | Main processor memory | Continued operation is not possible. Contact Field Service. |
| ERROR 09. Processor Fault. | DSP processor memory | Continued operation is not possible. Contact Field Service. |
| ERROR 10. Processor Fault. | DSP processor memory | Continued operation is not possible. Contact Field Service. |
| ERROR 11. Processor Fault. | DSP processor memory | Continued operation is not possible. Contact Field Service. |
| ERROR 12. Processor Fault. | DSP processor memory | Continued operation is not possible. Contact Field Service. |
| ERROR 14. Processor Fault. | DSP processor | Continued operation is not possible. Contact Field Service. |
| ERROR 15. Processor Fault. | DSP processor | Continued operation is not possible. Contact Field Service. |
| ERROR 16. Antenna Fault. | Antenna or antenna wiring | Weather mapping is inhibited. a. Check antenna wiring for opens and shorts. b. Contact Field Service. |
| ERROR 17. Processor Fault. | No test strikes, antenna in noisy location, or faulty antenna | Weather mapping is inhibited. a. Check antenna wiring for opens and shorts. b. Fault will clear automatically if interference subsides. c. Contact Field Service. |

Table 7. Thunderstorm/Lightning Detector Error Codes

| Error | Probable Cause | Corrective Action |
|--------------------------------------|---|--|
| ERROR 18. Processor Fault. | Invalid test strikes, antenna in noisy location, or faulty antenna | Weather mapping is inhibited. <ul style="list-style-type: none"> a. Check antenna wiring for opens and shorts. b. Fault will clear automatically if interference subsides. c. Contact Field Service. |
| ERROR 19. Processor Fault. | Main Processor or Antenna in noisy location | Weather mapping is inhibited. <ul style="list-style-type: none"> d. Fault will clear automatically if interference subsides. e. Contact Field Service. |
| ERROR 20. Configuration Changed. | Antenna location (top/bottom, determined by processor wiring) changed since system was last powered up. | This may occur the first time the system is powered on in a new installation. Power the sensor off and back on again. If the error persists, contact Field Service. |
| ERROR 21. Processor Fault. | Main processor | Continued operation is not possible. Contact Field Service. |
| ERROR 22. Invalid XYZ Input. | n/a | n/a |
| ERROR 23. Invalid Heading Ref. | n/a | n/a |
| ERROR 24. MIC KEY STUCK. | Mic key (inhibit line) has been asserted for at least 60 seconds | Weather mapping is inhibited. <ul style="list-style-type: none"> a. Contact Field Service. |
| ERROR 25 - 34. Processor Fault. | Main processor | Continued operation is not possible. Contact Field Service. |
| ERROR 35. Processor Fault. | Main or DSP processor | Continued operation is not possible. Contact Field Service. |
| ERROR 36. Processor Fault. | Main or DSP processor | Continued operation is not possible. Contact Field Service. |
| ERROR 40. Processor Fault. | Main processor | Continued operation is not possible. Contact Field Service. |
| ERROR 41. Processor Fault. | Main or DSP processor | Continued operation is not possible. Contact Field Service. |
| ERROR 42. Processor Fault. | Main processor | Continued operation is not possible. Contact Field Service. |
| ERROR 43. Invalid request. | DCP | Message error will clear once processed <ul style="list-style-type: none"> a. Excessive noise on communication lines, check wiring. b. If error occurs frequently, contact Field Service |
| ERROR 44 - 49. Serial Communication. | DCP | Message error will clear once processed <ul style="list-style-type: none"> a. Improper baud rate from DCP. b. Excessive noise on communication lines, check wiring. c. If error occurs frequently, contact Field Service. |

Table 7. Thunderstorm/Lightning Detector Error Codes

| Error | Probable Cause | Corrective Action |
|--|----------------|---|
| ERROR 50. Illegal Serial Heading Value. | DCP | Message error will clear once processed <ol style="list-style-type: none"> a. Excessive noise on communication lines, check wiring. b. If error occurs frequently, contact Field Service. |
| ERROR 51. Invalid Message. | DCP | Message error will clear once processed <ol style="list-style-type: none"> a. Excessive noise on communication lines, check wiring. b. If error occurs frequently, contact Field Service |
| ERROR 52. Invalid Antenna Change Request. | DCP | Message error will clear once processed <ol style="list-style-type: none"> a. A request was received to change the antenna mount to a location that does not match the configuration jumpers. Request is ignored. b. If error occurs frequently, contact Field Service. |
| ERROR 53 - 54. Communications Buffer Overload. | DCP | Message error will clear once processed <ol style="list-style-type: none"> a. Excessive noise on communication lines, check wiring. b. If error occurs frequently, contact Field Service. |

Table 7. Thunderstorm/Lightning Detector Error Codes

6.1 Processor Leds

The processor (housed within the enclosure) is equipped with a series of LEDs on its front panel (see Figure 9) that can be used to monitor certain basic functions. Table 8 explains how to interpret the LEDs.

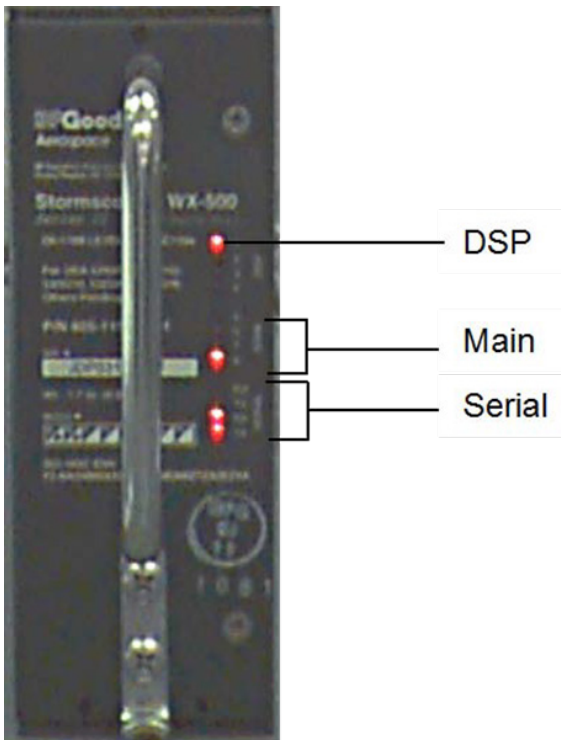

Figure 9. Processor Front Panel LEDs

| Communication | LED | Normal Operation | Failed Operation |
|-----------------------------------|-----|-------------------------------------|---|
| DSP (Digital Signal Processor) | 1 | ON | OFF |
| MAIN | 6 | Toggles ON/OFF when strike detected | Does not toggle ON/OFF when strike detected |
| | 7 | OFF | ON |
| | 8 | Toggles ON/OFF once per second | Stays ON or OFF (does not toggle) |
| SERIAL | TX | Reserved for future use | Reserved for future use |
| | RX | Reserved for future use | Reserved for future use |
| | TX | ON (pulses when TX occurs) * | Stays OFF or ON (does not pulse) |
| | RX | ON (pulses when TX occurs) * | Stays OFF or ON (does not pulse) |

Table 8. Processor LED Functions

* Serial communication occurs every 2 seconds, causing LEDs to pulse rapidly. Due to transmission speed, LEDs may appear not to change conditions during TX/RX operation.

7. Maintenance

The routine maintenance described in this chapter must be performed according to the schedule presented in Section 7.1 using the maintenance procedures described in Section 7.2.

7.1 Periodic Maintenance Schedule

Periodic maintenance procedures for the Model 6500 Thunderstorm/Lightning Detector are divided into three categories within the maintenance cycle — monthly, triannual, and annual maintenance.

7.1.1 Monthly Maintenance

No monthly maintenance is required for this sensor.

7.1.2 Triannual Maintenance

Perform the following maintenance tasks triannually:

- Check the antenna for dents, cracks, or punctures.
- Remove all dirt and grease from surface areas using a soft cloth moistened with mild soap and water.
- Check the sealant around the antenna base and mounting bolts, and reapply as necessary (use RTV 162).
- Check all hardware for corrosion and ensure that all bolts and connectors are tight.
- Ensure that the cable connections are sound between the sensor and DCP.

7.1.3 Annual Maintenance

- Perform the procedures outlined for triannual maintenance.

7.2 Maintenance Procedures

7.2.1 Equipment Required

The following equipment is required for the Model 6500 Thunderstorm/Lightning Detector maintenance procedures.

- RTV 162 (as necessary)

8. Specifications

| Parameter | Specification | | |
|-------------------------------|--|--------------------------|-------------|
| | 6500-DC | 6500-AC | 6500/6500-I |
| Measuring Range | 0 – 200 nautical miles (0 – 370 km) | | |
| Operating Temperature | -67 to +158°F (-55 to +70°C) | | |
| Storage Temperature | -103 to +158°F (-75 to +70°C) | | |
| Humidity | Noncondensing up to 100% | | |
| Serial Protocol | RS-422 | RS-485 | |
| Baud Rate | 9600 bps | 4800 bps | |
| Serial Port Parameter Setting | 8-N-1 (8 data bits, no parity, 1 stop bit) | | |
| Serial Connector | Screw terminal block pins | | |
| Supply Voltage | 11–32 V DC | 115 V/230 V AC, 50/60 Hz | |
| Power Consumption | 11 W | | |
| Enclosure | NEMA 4X painted aluminum | | |
| Mounting | Mounts to 2.5" pipe (2.875" O.D.) | | |
| Dimensions | 27.5" W × 30.9" L × 9.0" D (700 mm × 790 mm × 230 mm) | | |
| Weight | 35 lb (16 kg) | | |
| Shipping Weight | 40 lb (18 kg) | | |

9. Warranty

Unless specified otherwise, ADB Safegate. (the Company) warrants its products to be free from defects in material and workmanship under normal use and service for one year from date of installation or a maximum of two years from date of shipment, subject to the following conditions.

- a. The obligation of the Company under this warranty is limited to repairing or replacing items or parts which have been returned to the Company and which upon examination are disclosed, to the Company's satisfaction, to have been defective in material or workmanship at time of manufacture.
- b. The claimant shall pay the cost of shipping any part or instrument to the Company. If the Company determines the part to be defective in material or workmanship, the Company shall prepay the cost of shipping the repaired instrument to the claimant. Under no circumstances will the Company reimburse claimant for cost incurred in removing and/or reinstalling replacement parts.
- c. This warranty shall not apply to any Company products which have been subjected to misuse, negligence or accident.
- d. This warranty and the Company's obligation thereunder is in lieu of all other warranties, express or implied, including warranties of merchantability and fitness for a particular purpose, consequential damages and all other obligations or liabilities.

No other person or organization is authorized to give any other warranty or to assume any additional obligation on the Company's behalf, unless made in writing and signed by an authorized officer of the Company.

Optimizing Airside Operations From approach to take-off

SMARTER. BETTER. **NOW.**

**ADB
SAFEGATE**
www.adbsafegate.com