



Model 8522

30 ft AWOS Tilt Tower

PRODUCT MANUAL
8522/Rev B

ADB
SAFEGATE

A.0 Disclaimer / Standard Warranty

CE certification

The equipment listed as CE certified means that the product complies with the essential requirements concerning safety and hygiene. The European directives that have been taken into consideration in the design are available on written request to ADB SAFEGATE.

ETL certification

The equipment listed as ETL certified means that the product complies with the essential requirements concerning safety and C22.2 No.180:13 (R2018) regulations. The CSA directives that have been taken into consideration in the design are available on written request to ADB SAFEGATE.

All Products Guarantee

ADB SAFEGATE will correct by repair or replacement per the applicable guarantee below, at its option, equipment or parts which fail because of mechanical, electrical or physical defects, provided that the goods have been properly handled and stored prior to installation, properly installed and properly operated after installation, and provided further that Buyer gives ADB SAFEGATE written notice of such defects after delivery of the goods to Buyer. Refer to the Safety section for more information on Material Handling Precautions and Storage precautions that must be followed.

ADB SAFEGATE reserves the right to examine goods upon which a claim is made. Said goods must be presented in the same condition as when the defect therein was discovered. ADB SAFEGATE further reserves the right to require the return of such goods to establish any claim.

ADB SAFEGATE's obligation under this guarantee is limited to making repair or replacement within a reasonable time after receipt of such written notice and does not include any other costs such as the cost of removal of defective part, installation of repaired product, labor or consequential damages of any kind, the exclusive remedy being to require such new parts to be furnished.

ADB SAFEGATE's liability under no circumstances will exceed the contract price of goods claimed to be defective. Any returns under this guarantee are to be on a transportation charges prepaid basis. For products not manufactured by, but sold by ADB SAFEGATE, warranty is limited to that extended by the original manufacturer. This is ADB SAFEGATE's sole guarantee and warranty with respect to the goods; there are no express warranties or warranties of fitness for any particular purpose or any implied warranties of fitness for any particular purpose or any implied warranties other than those made expressly herein. All such warranties being expressly disclaimed.

Standard Products Guarantee

Products manufactured by ADB SAFEGATE are guaranteed against mechanical, electrical, and physical defects (excluding lamps) which may occur during proper and normal use for a period of two years from the date of ex-works delivery, and are guaranteed to be merchantable and fit for the ordinary purposes for which such products are made.

NOTE



See your applicable sales agreement for a complete warranty description.

Replaced or repaired equipment under warranty falls into the warranty of the original delivery. No new warranty period is started for these replaced or repaired products.

FAA Certified products manufactured by ADB SAFEGATE

ADB SAFEGATE L858 Airfield Guidance Signs are warranted against mechanical and physical defects in design or manufacture for a period of 2 years from date of installation, per FAA AC 150/5345-44 (applicable edition).

ADB SAFEGATE LED products (with the exception of obstruction lighting) are warranted against electrical defects in design or manufacture of the LED or LED specific circuitry for a period of 4 years from date of installation, per FAA EB67 (applicable edition). These FAA certified constant current (series) powered LED products must be installed, interfaced and powered with and through products certified under the FAA Airfield Lighting Equipment Program (ALECP) to be included in this 4 (four) year warranty. This includes, but is not limited to, interface with products such as Base Cans, Isolation Transformers, Connectors, Wiring, and Constant Current Regulators.

Contents

1. Overview	5
1.1 Obstruction Light Kits.....	5
1.2 Compliance.....	5
2. Installation	6
2.1 Tools	6
2.2 Foundation	6
2.2.1 Cylindrical Foundation.....	7
2.2.2 Square Foundation.....	8
2.2.3 Anchor Bolts	9
2.2.4 Foundation Kit	10
2.3 Tower Assembly.....	10
2.4 Tower Obstruction Lights.....	17
2.5 Lightning Rod And Ground Rod.....	18
2.5.1 Lightning Rod.....	18
2.5.2 Ground Rod.....	18
2.5.3 Down Conductor.....	19
3. Maintenance	20
3.1 Monthly Maintenance	20
3.2 Triannual Maintenance.....	20
3.3 Winch Operation	21
Appendix — Torque Specifications	23

Revision History

Revision	Date	Summary of Changes
A	2024 June 4	Initial release
B	2025 Apr 1	ADB SAFEGATE (ECP#ADBSG-0001)

1. Overview

The Model 8522 Tilt Tower is made of light weight, high grade aluminum alloy, and is suitable for the most extreme environmental conditions with high wind, ice, UV, and saltwater exposure. The cross bracing is a zigzag design of continuous, solid aluminum alloy rods.

The tower consists of four 2.25 m [7.38 ft] sections and a circular pole that extends 60–940 mm [2.4"–37"] above the top of the tower. The tower sections are painted in seven bands of orange and white. The hinge point at the top of the first section is operated mechanically using a worm gear winch (self-locking) and tilt tube. A winch is fastened to the tower using three wing nuts and allows the tower to be lowered/raised at the hinge point. Both the winch and the tilt tube are removable, them to be used then stored when not in use. This makes it practical to assemble the tower close to the ground level and to access the sensors at the top by lowering/raising the tower, allowing a single person to service the equipment easily without climbing the tower or using a bucket truck.

The 8522 Tilt Tower is engineered to withstand winds with a safety factor of 1.5. Table 1 shows the design wind and ice loads for an equipment effective projected area of 0.6 m² [6.45 ft²] Up to 14 kg may be installed at the top of the tower.

Radial Ice	Design Wind
0"	80 mph
0.5"	71 mph
1.0"	62 mph
1.5"	55 mph

Table 1. Allowable Equipment Area

1.1 Obstruction Light Kits

The following obstruction light kits are offered for use with the 8522 Tilt Tower.

Part Number	Description
85091	Dual 120 V Incandescent Obstruction Light Kit
M488276-00	Dual 120 V LED Obstruction Light Kit

1.2 Compliance

The 8522 Tilt Tower complies with these standards.

- FAA AC 150/5345-45C
- ICAO DOC 9157
- ICAO ANNEX 14
- Transport Canada TP312

2. Installation

2.1 Tools

The following tools are required to install the tower:

- Wrench or Socket Set (7/16" to 1½")
- Torque Wrench
- Ladder or Crane
- Level
- Drill and ¾" Socket (for Winch)

2.2 Foundation

The 8522 Tilt Tower must be mounted in a concrete base. Anchor bolts are included with the tower, and are set in the concrete according to the pattern described in Section 2.2.3.

The tower should be installed according to local building codes. When used in an AWOS system, install the tower according to the AWOS Site Preparation Manual specific to your AWOS system.

Standard foundation designs must be in accordance with ANSI/TIA-222-H, "Structural Standards for Steel Antenna Towers and Antenna Supporting Structures," Section 9 and Annex F for the following presumptive clay soil parameters.

N	ϕ	Y	C	Ultimate Bearing		Ultimate Skin Friction	k	ϵ_{50}
				Shallow Ends	Deep Ends			
8 blows/ft 26 blows/m	0°	110 lb/ft ³ 17 kN/m ³	1000 lb/ft ² 48 kPa	5000 lb/ft ² 240 kPa	9000 lb/ft ² 430 kPa	500 lb/ft ² 24 kPa	150 lb/in ³ 41,000 kN/m ³	0.01

Actual site soil parameters must be verified to meet or exceed ANSI/TIA-222-H presumptive clay soil design parameters. The depth of standard foundations must be adequate based on frost penetration and/or seasonal moisture variation zones at the site. Foundation design modifications may be required if the presumptive clay soil parameters are not applicable for the actual subsurface conditions encountered.

All foundation work must be in accordance with local codes, safety regulations, and (unless otherwise allowed) the latest revision of ACI 318, "Building Code Requirements for Reinforced Concrete." Procedures for the protection of excavations, existing construction, and utilities must be established before installing any foundations.

If the terrain is not level, orient the foundation so that the tower will tilt in the uphill direction.

2.2.1 Cylindrical Foundation

Figure 1 provides the details for the cylindrical foundation. *This foundation is not recommended for hard clay soils.*

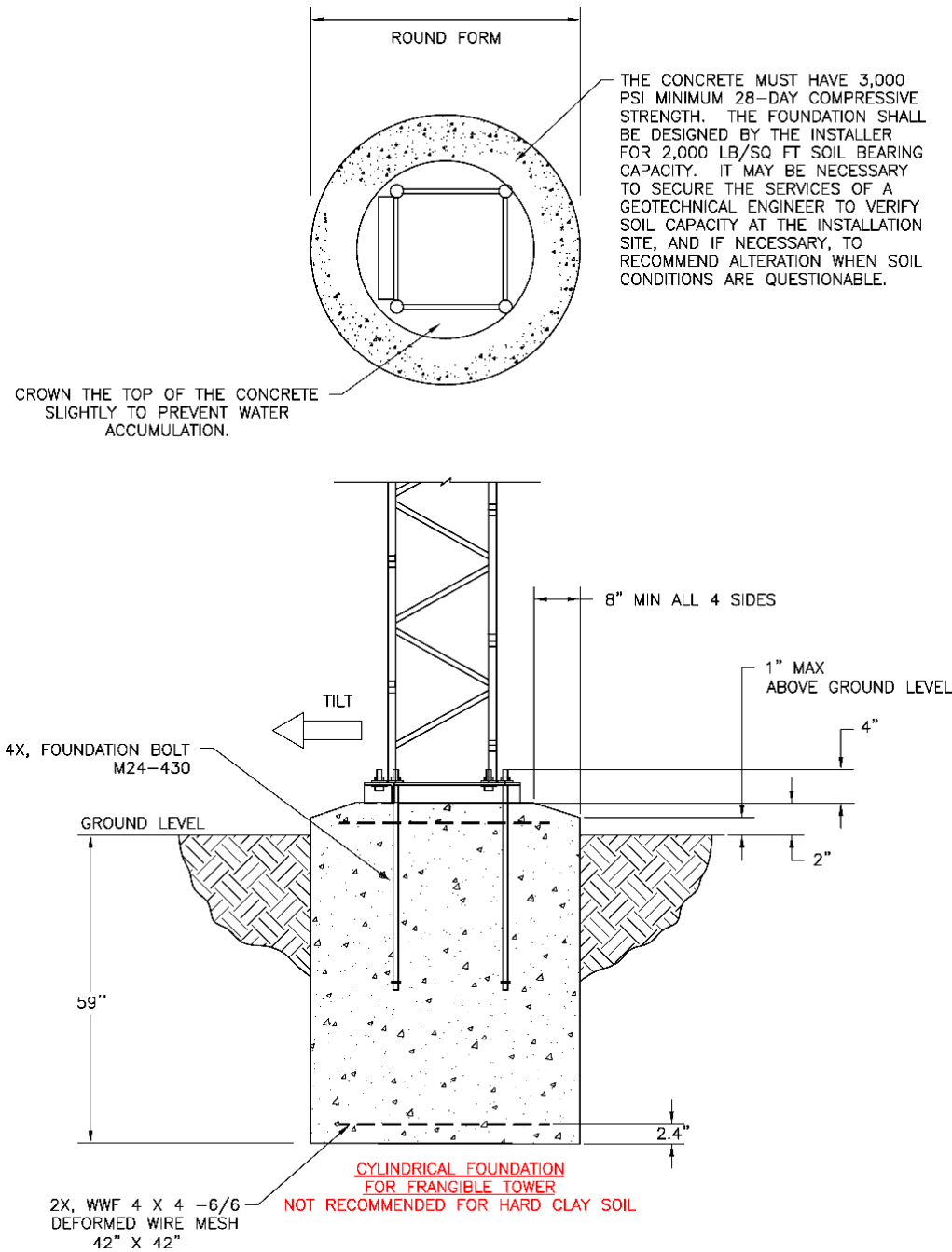

Figure 1. 8522 Tilt Tower Cylindrical Foundation

The base of the footing section should extend four inches below the concrete into compacted sand and gravel to allow for drainage.



NOTE

Bottom of the foundation must be below the local frost line in areas where frost occurs.

2.2.2 Square Foundation

Figure 2 provides the details for the square foundation.

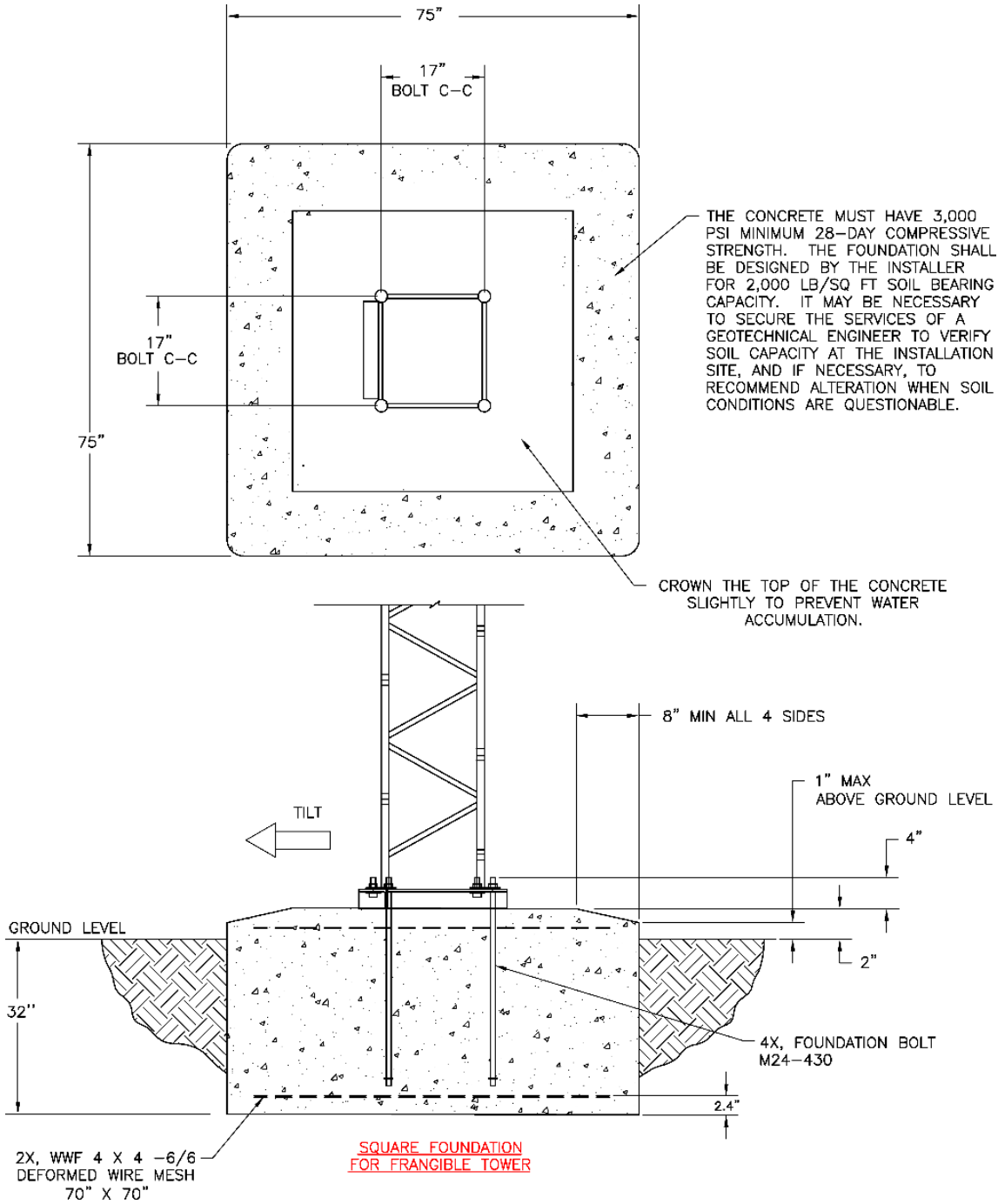

Figure 2. 8522 Tilt Tower Square Foundation

The base of the footing section should extend four inches below the concrete into compacted sand and gravel to allow for drainage.



NOTE

Bottom of the foundation must be below the local frost line in areas where frost occurs.

2.2.3 Anchor Bolts

Hot dipped galvanized steel anchor bolts are supplied along with a wood template to be used to set the anchor bolts in the foundation. Figure 3 shows the anchor bolt template.

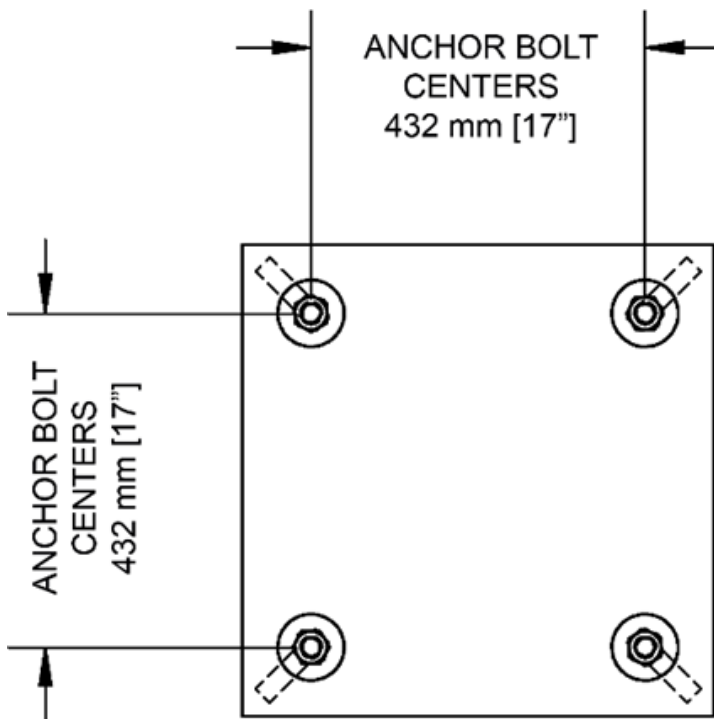

Figure 3. Anchor Bolt Template

Place one hex nut with a washer above it on each of the anchor bolts as shown in Figure 4 so the hex nuts are about 85 mm [3.35"] from the top end of the anchor bolts. Place the template over the newly poured foundation and insert the anchor bolts through the template.

Position the bolts and the template so the bottom of the template is 80 mm [3.14"] above the foundation and the tops of the anchor bolts are 152 mm [6.0"] above the top of the foundation. Use a level and adjust the hex nuts to make sure the wood template is as level as possible.

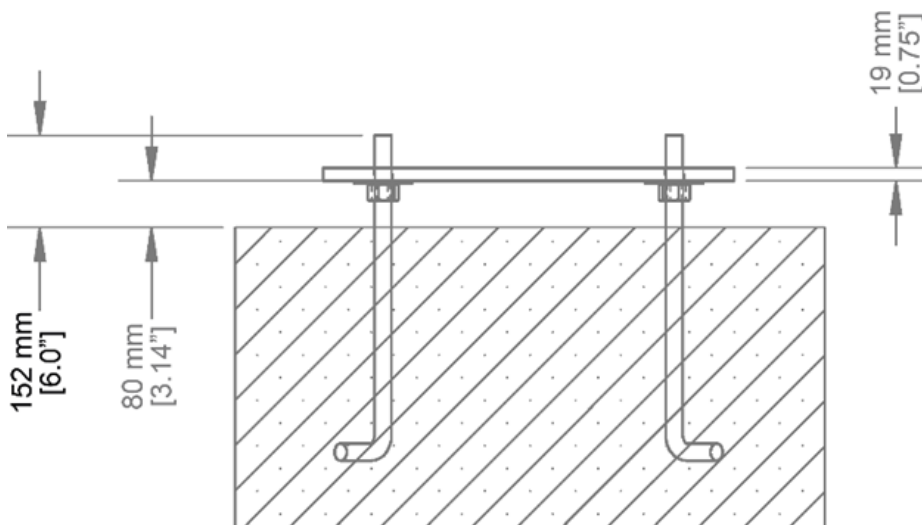

Figure 4. Position Anchor Bolts and Template

The template may be removed once the concrete starts to set. Set the remaining hex nuts and washers aside to secure the bottom tower section.

2.2.4 Foundation Kit

A foundation kit is provided with the tower. The foundation kits contains

- The wooden anchor bolt template,
- 4 anchor bolts, and
- 8 washers and hex nuts.

2.3 Tower Assembly

The tower may be erected using the supplied hardware once the foundation has set. The tower has four sections and a pole at the top.

Tower Section	Width	Leg Diameter	Lattice Diameter
7T16	167mm [6.56"]	14.3 mm [9/16"]	8 mm [5/16"]
9T17	230 mm [9.00"]	14.3 mm [9/16"]	8 mm [5/16"]
13T27	330 mm [13"]	17.5 mm [11/16"]	9.5 mm [3/8"]
13S36	330 mm [13"]	17.5 mm [11/16"]	9.5 mm [3/8"]

Table 2. Tower Section Properties

The bottom section (13S36) has a square cross section, the remaining sections above it have a triangular cross section.

Sections will have either *closed* or *open* ends, as described below. For sections that have both a closed and open end, install the open towards the base.

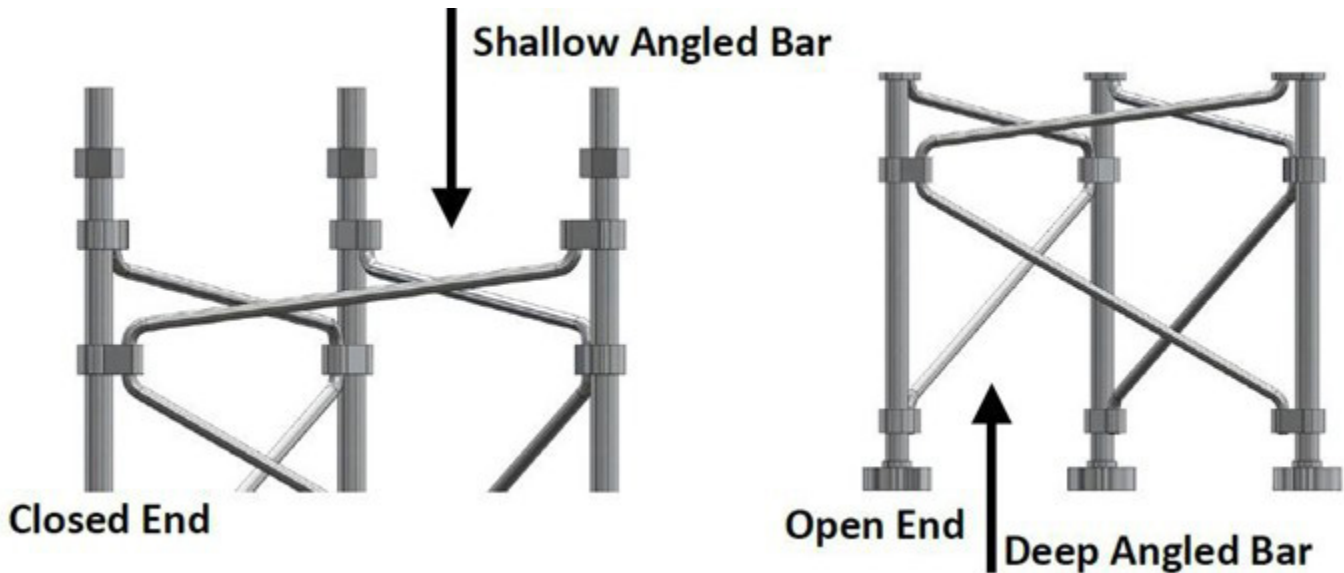

Figure 5. Ends of Tower Sections

Sections of different face width or shape attach using a transition plate with a nut-nut connection (Figure 6).

1. Slide the threaded legs on the bottom end of the smaller mast section into the transition plate first.
2. Secure the mast section with nuts and torque to the specified value. Apply light oil or anti-seize to the thread to prevent seizing.
3. Repeat Steps 1 and 2 for the larger mast section.

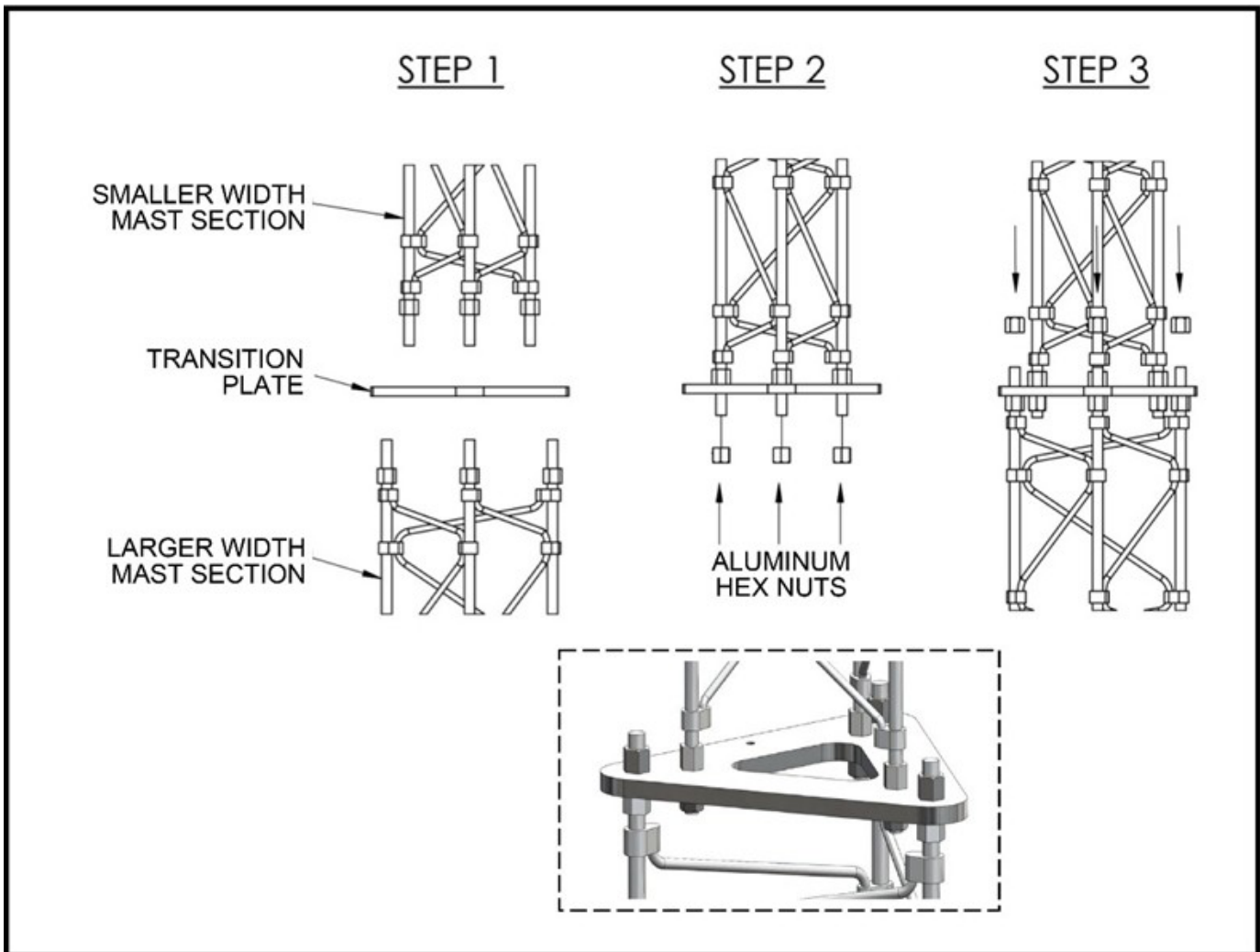

Figure 6. Joining Tower Sections

Sections are machined during the manufacturing process to ensure that the assembly is plumb once installed. Nuts are set during the manufacturing process and should not be removed or adjusted. This may cause unwanted damage to the thread or result in the mast being installed crooked.

All bolts must be tightened to a "snug tight condition" as defined in the June 23, 2000, AISC **Specification for Structural Joints Using ASTM325 or A490 Bolts**. Do so before completing the last step. Refer to the Appendix.

Model 8522 30 ft AWOS Tilt Tower

The steps in the rest of this section detail how to assemble all the tower components.

1. The 13S36 section is threaded at both ends. Bolt the base plate to the bottom of the 13S36 section and fully torque the nuts. The base plate may already be secured, skip this step in that case.



2. Attach the hinge plate to the top of the 13S36 section and secure it with aluminum nuts.



3. Attach the two aluminum hinge blocks to the top of the 13T27 hinge plate using 0.5" x 4.25" hardware. Then slide the hinge pin through both blocks.



4. Placing the assembled top hinge plate with blocks on top of the bottom hinge plate (as shown), secure the hinge pin by sliding the aluminum hinge end blocks over the ends of the hinge pin and bolt to the bottom hinge plate with 0.5" x 4.25" hardware. It is recommended that all hinge-related bolts are finger tighten until the alignment is checked on all parts and all plates/ angles are mounted square to each other.



NOTE

Hinge pin is considered the "rear" of the tower, and is the direction that the tower will tilt down to the ground to be serviced.

5. One nut and flat washer are already secured on each of the anchor bolts as shown.

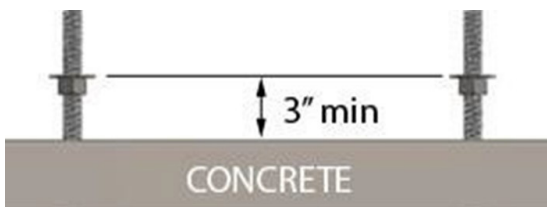

Model 8522 30 ft AWOS Tilt Tower

The steps in the rest of this section detail how to assemble all the tower components.

6. If the terrain is not level, the foundation should have been oriented so that the tower will tilt in the uphill direction. Identify the tilt direction if this is the case, and lift the tower base with the 13S36 section over the anchor bolts so that the tilt direction is correct. Slide the bolts through the corresponding holes. The base plate is attached to the foundation using the anchor bolts. Adjust the nuts and flat washers to ensure the base plate is level.

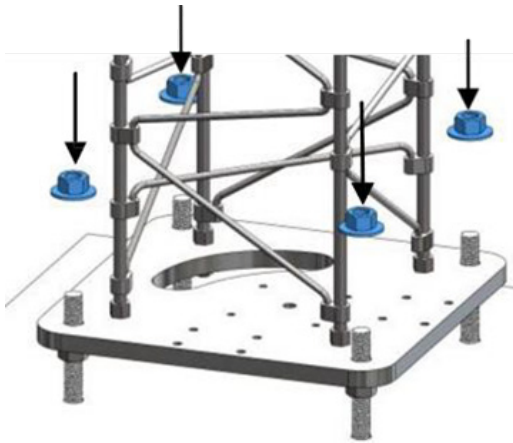

7. Once the base plate is level, secure the base plate using the second set of nuts and flat washers.

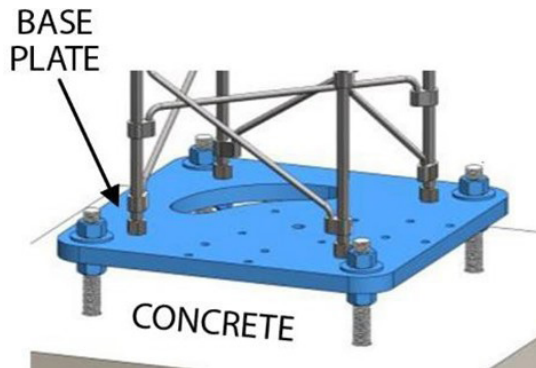

8. Install the removable tilt tube assembly onto the hinge plate using four $\frac{3}{4}$ -10 x 3 hex bolts, nuts, and lock washers.

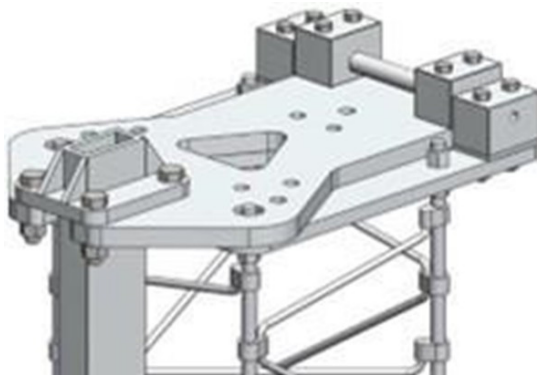

Model 8522 30 ft AWOS Tilt Tower

9. Open the hinge plate assembly to approximately a 90° angle. Insert the threaded legs of the 13T27 tower section into the holes on the top hinge plate and secure with the aluminum nuts, fully torqued.

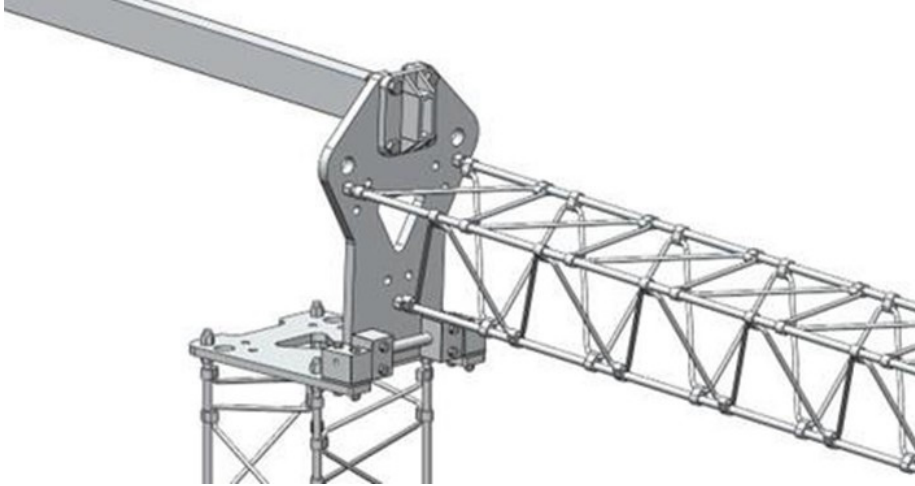

10. Attach the 13T-9T plate to the opposite end of the 13T27 tower section, and secure with the aluminum nuts and torque. Continue and insert the threaded legs of the 9T17 section into the corresponding holes on the 13T-9T plate and secure with aluminum nuts and torque. Repeat this procedure using the 9T-7T plate, aluminum nuts, and the 7T10 tower section.

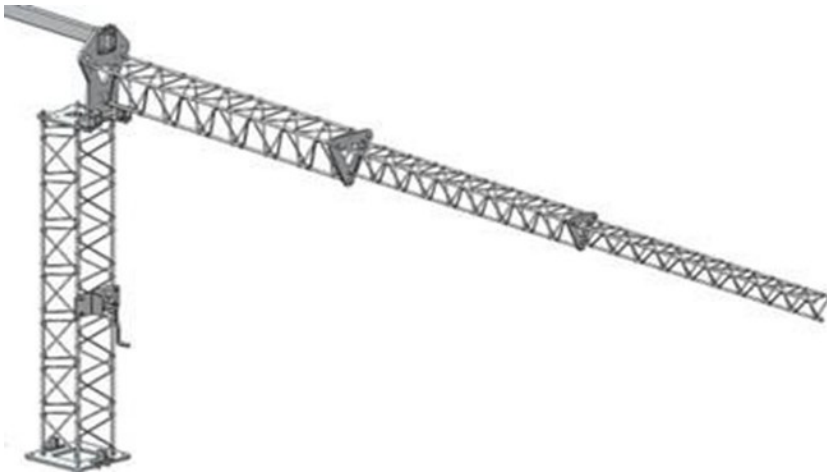

11. Secure the horizontal universal bracket for the top pole with the 3/8"-16 x 4" hex bolt and flange nut.

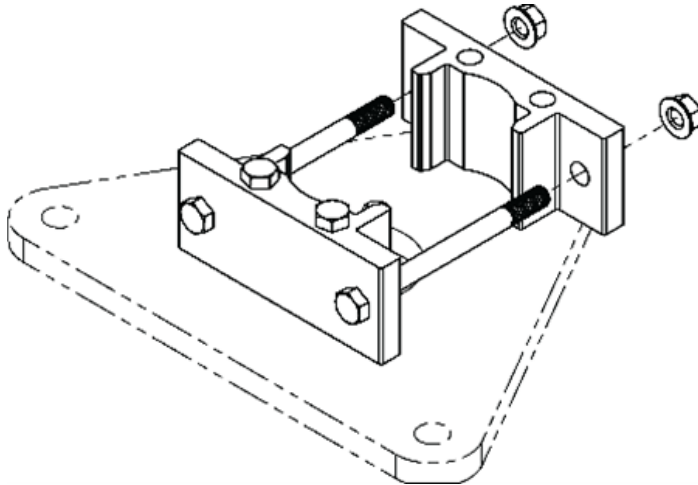

12. Secure the universal bracket for the top pole vertically with the 3/8"-16 x 4" hex bolt and flange nut.

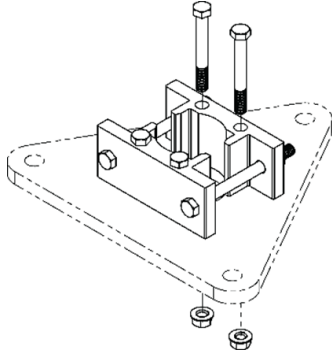

13. Position the top pole so that the top is 2.4" to 34" above the mounting plate.

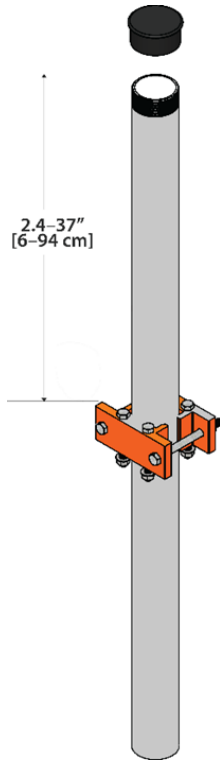

14. Use the 13T U-bolts and 5/16" nuts and lock washers to bolt the winch assembly by the winch plate to the rear face of the 13S36 tower section. Attach the handle.

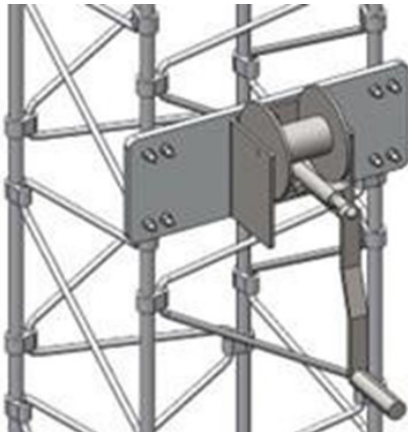

Model 8522 30 ft AWOS Tilt Tower

15. Install the two sheave sets onto the base plate using 7/16"-14 x 2 hex bolts, nuts, and lock washers. Next, install a pulley onto each set of sheaves and secure them into place using the 3/4"-10 x 3" adjustable clevis pin as shown.



16. Install the winch cable by threading it through the pulleys mounted to the base plate, then up to the bottom of the tilt tube assembly. The winch cable terminates at the tilt tube assembly with a single 1/2"-13 x 2.75" bolt, nut, and lock washer.

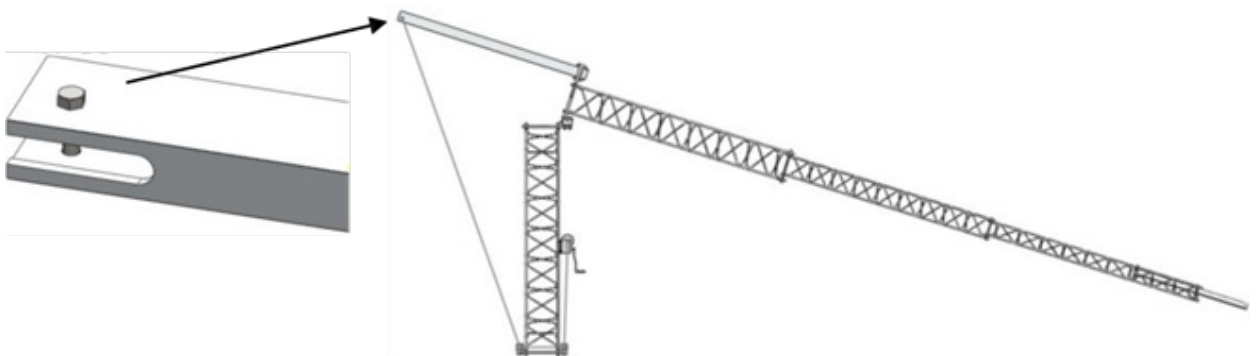

17. Use the winch to crank the handle and lift the tower to its fully vertical position, then secure the top and bottom hinge plates with the 5/8" x 2-1/2" hardware.

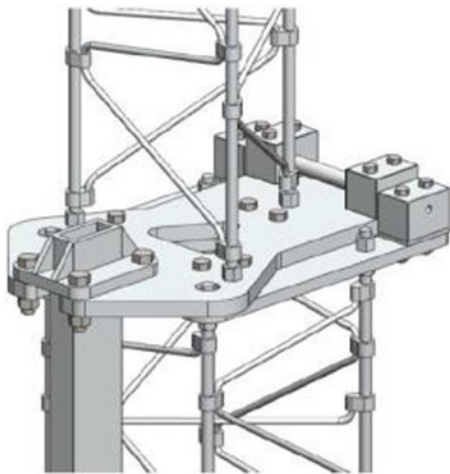

This completes the tower assembly. Once the tower is locked into place, the tilt tube assembly, sheave sets and clevis pins can all be removed. The winch assembly can also be taken off by removing the bolts and hardware from the winch plate, then dismantling the winch assembly for storage and future servicing.



NOTE

Obstruction lights must be in place and operational before dusk the day the tower is erected.

2.4 Tower Obstruction Lights

Figure 7 shows the details to install tower lights.

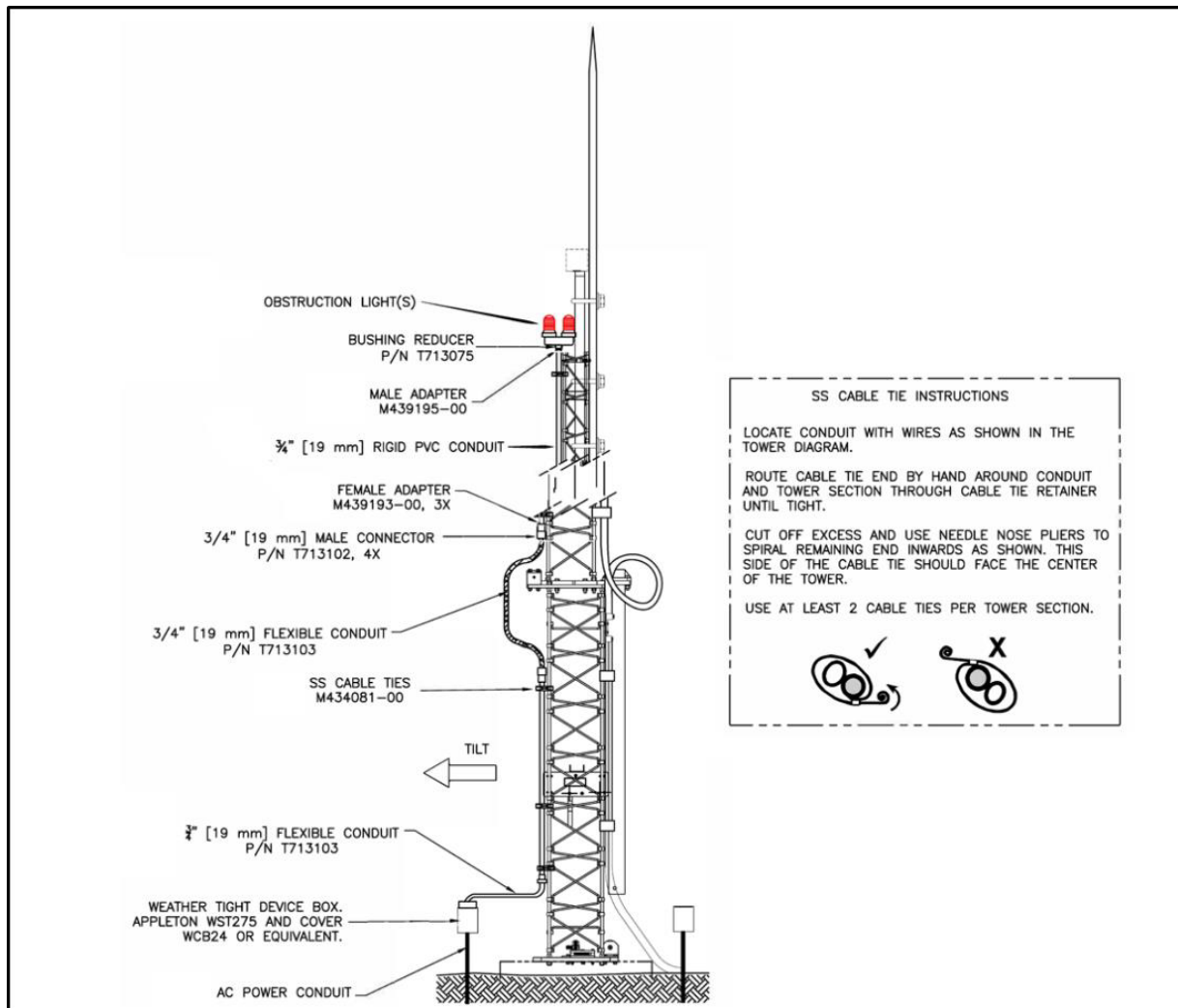

Figure 7. Installation of Obstruction Lights

1. Mount the obstruction lights at the top of the tower.
2. Cut the 3/4" conduit to the lengths required to fit the installation.
3. Install the conduit next to the tower leg on the inside of the tower frame, and secure the conduit to the tower leg approximately every meter (every 3 to 4 ft) using the stainless-steel cable ties provided. Take care to not over-tighten and damage the tower legs. (Refer to the directions in Figure 7 for using the cable ties.)
4. Provide enough slack in the flexible conduit at the tilt hinge to allow the tower to be tilted over without stressing the flexible conduit.
5. Cut the flexible conduit at the base of tower to the length required to connect it to the circuit breaker panel or AC power junction box.
6. Attach the fittings and conduit together using PVC cement.
7. Route wire through the conduit from the circuit breaker panel or junction box to wire the obstruction lights in parallel. The obstruction lights should be on a dedicated circuit.

2.5 Lightning Rod And Ground Rod

2.5.1 Lightning Rod

A lightning rod must be installed onto the tower. Refer to Figure 8.

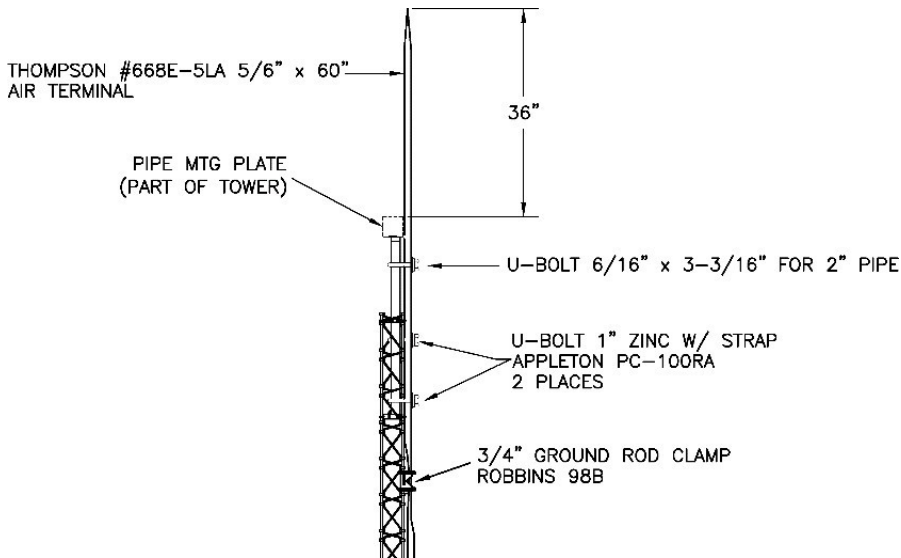

Figure 8. Lightning Rod Installation

2.5.2 Ground Rod

The tower and lightning rod must be grounded as shown in Figure 9.

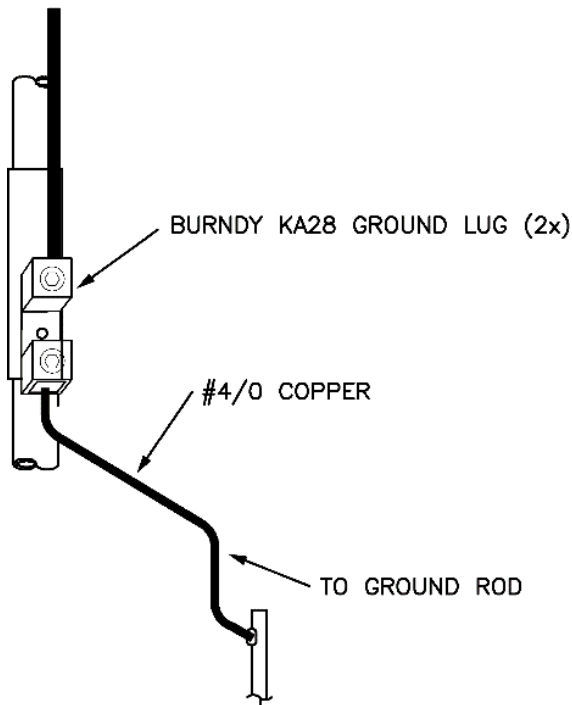

Figure 9. Tower Ground Rod and Grounding

Sink the ground rod firmly into the ground, and then connect the ground wire.

2.5.3 Down Conductor

Run a #4/0 bare copper down conductor from the lightning rod clamp to the ground lug near the base of the tower. Route the down conductor wire along the inside of the tower frame and secure it to a tower leg with ultraviolet-resistant cable ties at least every meter (3 to 4 ft).

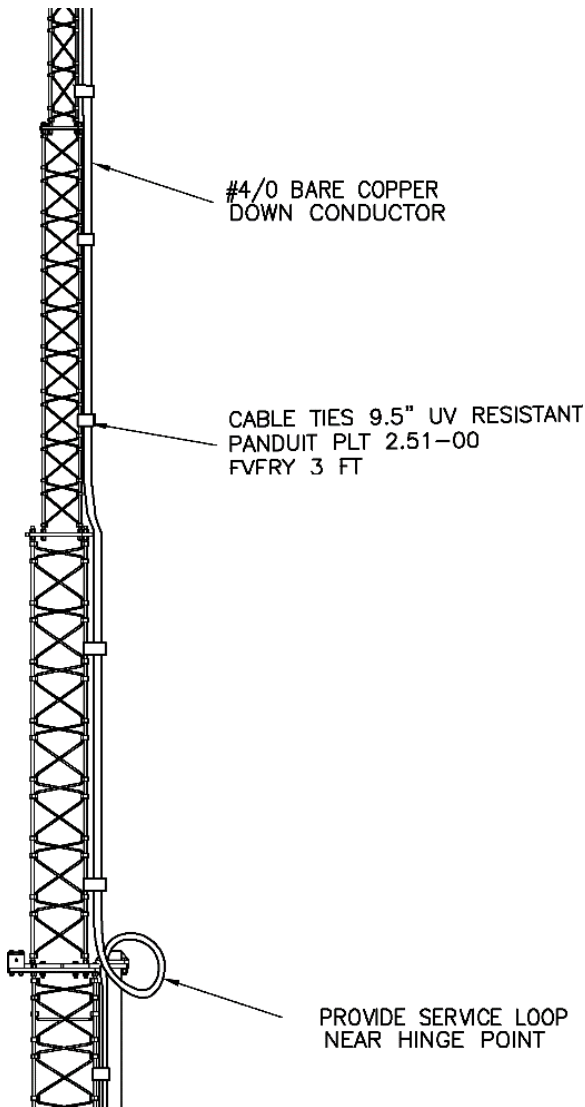

Figure 10. Route Down Conductor Inside Tower Frame

Check for ground continuity once the down conductor is connected. After checking the connections, additional ground rods may be needed for proper grounding. Local building codes may also require specific grounding beyond the minimum requirements described in this section.

3. Maintenance

During daily airfield inspections, the tower should be inspected visually from a distance to ensure that there are no obvious defects. The only expected maintenance required is replacing the tower obstruction light bulbs. Both bulbs should be replaced after one bulb fails.

The tower sections are powder coated. However, the powder coating is not integral to the tower's structure. Any chips or scuffs in the powder coating are strictly aesthetic and do not require repair. If desired, blemishes can be spray painted using aviation orange or white.

In addition to regular checks, it is recommended that towers are inspected after severe icing or wind storms.

3.1 Monthly Maintenance

Monthly maintenance consists of verifying visually that the tower obstruction lights are in working order. Replace both bulbs if either bulb fails. Also check whether the tower legs or lattice have been damaged or bent. Any damaged sections should be replaced.

3.2 Triannual Maintenance

Triannual maintenance consists of verifying visually that the tower obstruction lights are in working order. Replace both bulbs if either bulb fails.

Bolts and nuts will naturally loosen because of vibration and oscillating forces. For those within reach, a visual inspection should be made to determine whether the hardware has become loose or damaged (galled threads or cracked nuts). For sections that are unreachable, a light shake to the tower should produce a rattling noise if hardware has become loose. Bolts and nuts should be inspected and tightened to the appropriate torque on a regular basis or replaced as required. Anti-seize should always be used on hardware.

Foundation should be inspected for cracks, corrosion, and loose hardware. Any defects should be repaired accordingly. Note that some structural deficiencies are not always visible. Owner's may wish to have foundations inspected using technologies that will detect internal issues.

3.3 Winch Operation

The winch system is used to lower or raise the tower to allow maintenance to be done on the upper sections of the tower or on other devices installed higher up the tower. The winch system is designed to be installed and removed without the use of tools. Installation takes 1–2 minutes.

1. Attach the tilt tube assembly to the center hinge with the safety bolt/pin.

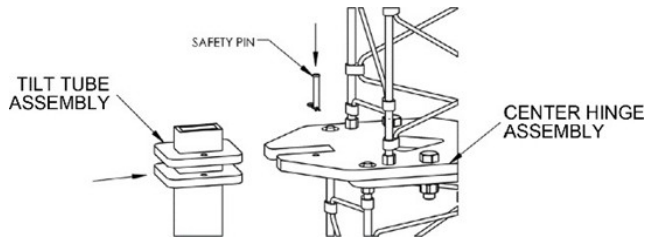

2. Mount the winch to the winch plate using the supplied hardware. The wing nuts used to attach the winch only need to be hand-tightened.

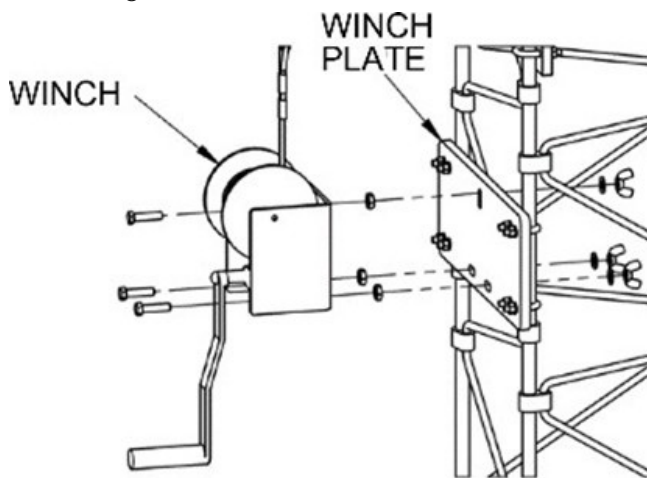

3. For easiest assembly, the wire rope should be placed around a sheave set before installing it on the tilt tube assembly. The wire rope is then routed in the groove of the double-purchase pulley and the open thimble is terminated at the pulley assembly with a clevis pin. Each sheave set at the tower base is then secured inside the tilt tube assembly using a clevis pin.

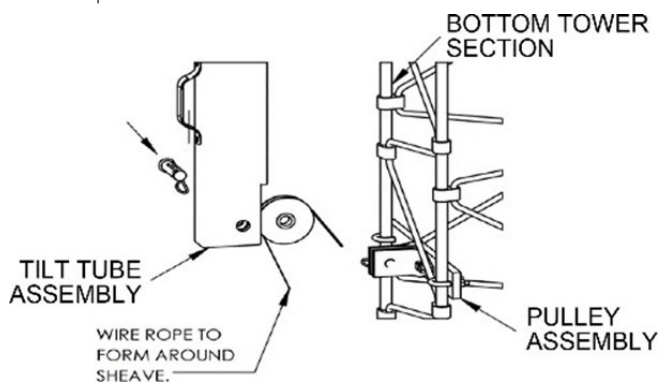

A drill with a $\frac{3}{4}$ " socket may be used to install or remove the nuts. The drill speed should not exceed 600 rpm.

Figure 10 summarizes the operation of the winch and pulley to lower or raise the tower.

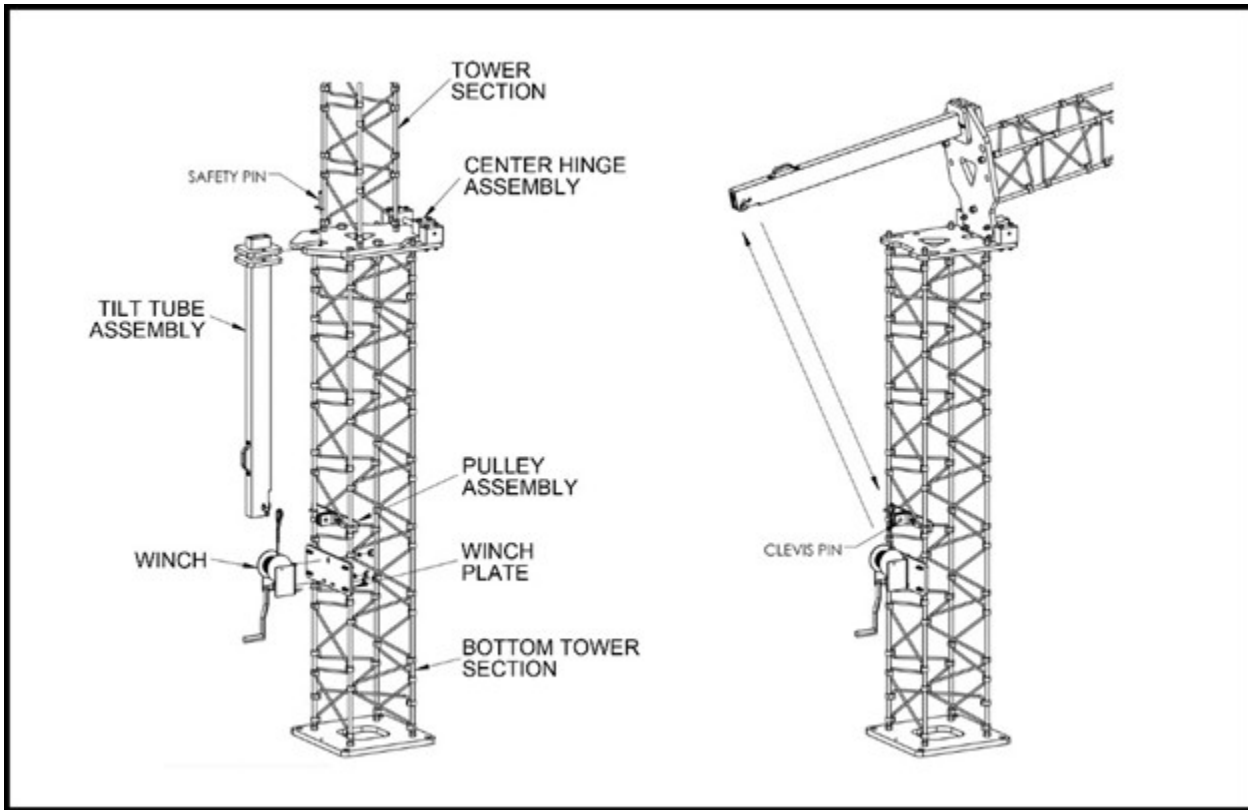

Figure 11. Winch and Pulley Operation to Lower/Raise Tower

To increase the lifespan of the winch, remove and place in storage when not in use.

Appendix — Torque Specifications

Bolt Size	18-8 Stainless Steel (n·m)	HD Galvanized Steel (n·m)	Aluminum 6061 T6 (n·m)
1/4"	8	8	4
3/16"	14	12	7
3/8"	23	19	16
7/16"	35	28	19
1/2"	50	50	26
9/16"	65	66	34
5/8"	106	99	60
11/16"	126	151	71
3/4"	146	175	82
1"	328	425	184

Optimizing Airside Operations From approach to take-off

SMARTER. BETTER. **NOW.**

**ADB
SAFEGATE**
www.adbsafegate.com