



# AGSB-L LED Airfield Guidance Sign

ICAO/TP 312

## User Manual

96A0467, Rev. 0, 2025/09/08

  
**ADB  
SAFEGATE**



## A.0 Disclaimer / Standard Warranty

### CE certification

The equipment listed as CE certified means that the product complies with the essential requirements concerning safety and hygiene. The European directives that have been taken into consideration in the design are available on written request to ADB SAFEGATE.

### ETL certification

The equipment listed as ETL certified means that the product complies with the essential requirements concerning safety and C22.2 No.180:13 (R2018) regulations. The CSA directives that have been taken into consideration in the design are available on written request to ADB SAFEGATE.

### All Products Guarantee

ADB SAFEGATE will correct by repair or replacement per the applicable guarantee below, at its option, equipment or parts which fail because of mechanical, electrical or physical defects, provided that the goods have been properly handled and stored prior to installation, properly installed and properly operated after installation, and provided further that Buyer gives ADB SAFEGATE written notice of such defects after delivery of the goods to Buyer. Refer to the Safety section for more information on Material Handling Precautions and Storage precautions that must be followed.

ADB SAFEGATE reserves the right to examine goods upon which a claim is made. Said goods must be presented in the same condition as when the defect therein was discovered. ADB SAFEGATE further reserves the right to require the return of such goods to establish any claim.

ADB SAFEGATE's obligation under this guarantee is limited to making repair or replacement within a reasonable time after receipt of such written notice and does not include any other costs such as the cost of removal of defective part, installation of repaired product, labor or consequential damages of any kind, the exclusive remedy being to require such new parts to be furnished.

ADB SAFEGATE's liability under no circumstances will exceed the contract price of goods claimed to be defective. Any returns under this guarantee are to be on a transportation charges prepaid basis. For products not manufactured by, but sold by ADB SAFEGATE, warranty is limited to that extended by the original manufacturer. This is ADB SAFEGATE's sole guarantee and warranty with respect to the goods; there are no express warranties or warranties of fitness for any particular purpose or any implied warranties of fitness for any particular purpose or any implied warranties other than those made expressly herein. All such warranties being expressly disclaimed.

### Standard Products Guarantee

Products manufactured by ADB SAFEGATE are guaranteed against mechanical, electrical, and physical defects (excluding lamps) which may occur during proper and normal use for a period of two years from the date of ex-works delivery, and are guaranteed to be merchantable and fit for the ordinary purposes for which such products are made.



### Note

See your applicable sales agreement for a complete warranty description.

Replaced or repaired equipment under warranty falls into the warranty of the original delivery. No new warranty period is started for these replaced or repaired products.

### FAA Certified products manufactured by ADB SAFEGATE

ADB SAFEGATE L858 Airfield Guidance Signs are warranted against mechanical and physical defects in design or manufacture for a period of 2 years from date of installation, per FAA AC 150/5345-44 (applicable edition).

ADB SAFEGATE LED products (with the exception of obstruction lighting) are warranted against electrical defects in design or manufacture of the LED or LED specific circuitry for a period of 4 years from date of installation, per FAA EB67 (applicable edition). These FAA certified constant current (series) powered LED products must be installed, interfaced and powered with and through products certified under the FAA Airfield Lighting Equipment Program (ALECP) to be included in this 4 (four) year warranty. This includes, but is not limited to, interface with products such as Base Cans, Isolation Transformers, Connectors, Wiring, and Constant Current Regulators.



## Note

See your sales order contract for a complete warranty description.

Replaced or repaired equipment under warranty falls into the warranty of the original delivery. No new warranty period is started for these replaced or repaired products.

---

## Liability



### WARNING

Use of the equipment in ways other than described in the catalog leaflet and the manual may result in personal injury, death, or property and equipment damage. Use this equipment only as described in the manual.

ADB SAFEGATE cannot be held responsible for injuries or damages resulting from non-standard, unintended uses of its equipment. The equipment is designed and intended only for the purpose described in the manual. Uses not described in the manual are considered unintended uses and may result in serious personal injury, death or property damage.

Unintended uses, includes the following actions:

- Making changes to equipment that have not been recommended or described in this manual or using parts that are not genuine ADB SAFEGATE replacement parts or accessories.
- Failing to make sure that auxiliary equipment complies with approval agency requirements, local codes, and all applicable safety standards if not in contradiction with the general rules.
- Using materials or auxiliary equipment that are inappropriate or incompatible with your ADB SAFEGATE equipment.
- Allowing unskilled personnel to perform any task on or with the equipment.

## Copyright Statement

This manual or parts thereof may not be reproduced, stored in a retrieval system, or transmitted, in any form or by any means, electronic, mechanical, photocopying, recording, nor otherwise, without the author's prior written consent.

This manual could contain technical inaccuracies or typographical errors. The author reserves the right to revise this manual from time to time in the contents thereof without obligation of the author to notify any person of such revision or change. Details and values given in this manual are average values and have been compiled with care. They are not binding, however, and the author disclaims any liability for damages or detriments suffered as a result of reliance on the information given herein or the use of products, processes or equipment to which this manual refers. No warranty is made that the use of the information or of the products, processes or equipment to which this manual refers will not infringe any third party's patents or rights. The information given does not release the buyer from making their own experiments and tests.

# Table of Contents

<b>1.0 Safety</b> .....	<b>1</b>
1.1 Safety Messages.....	1
1.1.1 Introduction to Safety.....	2
1.1.2 Intended Use.....	2
1.1.3 Material Handling Precautions: Storage.....	3
1.1.4 Material Handling: Heavy Equipment.....	3
1.1.5 Operation Safety.....	3
1.1.6 Maintenance Safety.....	4
1.1.7 Material Handling Precautions, ESD.....	4
1.1.8 Arc Flash and Electric Shock Hazard.....	5
<b>2.0 Introduction</b> .....	<b>7</b>
2.1 LED Light Bar Airfield Guidance Sign.....	7
<b>3.0 Installation</b> .....	<b>13</b>
3.1 Unpacking.....	13
3.2 Power Entry and Mounting Configurations.....	13
3.2.1 Power Through Bottom - Remote Mounting (Preferred - Canada).....	14
3.2.2 Power Through Leg - Remote Mounting (Preferred - FAA).....	15
3.2.3 Power Through Leg - Shallow Base Mounting (Alternate - FAA).....	15
3.2.4 Power Through Leg - Direct Mounting (Alternate - FAA).....	16
3.2.5 Power Through Side Panel - Without Flexible Conduit (Not FAA Compliant).....	17
3.2.6 Power Through Side Panel - Without Flexible Conduit (Not FAA Compliant).....	18
3.3 Cord sets and Extension Cords.....	18
3.4 General Guidelines.....	19
3.4.1 Overall Mounting Height.....	19
3.4.2 Dimension Diagrams for Installation.....	20
3.4.3 Sign Orientation.....	24
3.4.4 Sign Distance from Pavement Edge.....	24
3.4.5 Sign Installation on a Concrete Pad.....	24
3.4.6 Concrete Pouring.....	24
3.4.7 Sign Mounting.....	28
3.5 Wiring.....	30
3.6 Series Wiring Isolation Transformers.....	30
3.7 Earth Ground Lug.....	31
3.8 Tethers.....	32
<b>4.0 Maintenance and Repair</b> .....	<b>33</b>
4.1 Replacing a LED Light Bar.....	34
4.2 Replacing the Single Power Supply.....	35
4.2.1 Wiring the Single Power Supply.....	35
4.2.2 Checking the Power Supply.....	36
4.3 Replacing the Dual Power Supply.....	36
4.3.1 Wiring the Dual-Power Supply.....	37
4.3.2 Checking the Dual Power Supply.....	38
4.4 Sign Bolt Torque Diagram.....	39
<b>5.0 Troubleshooting</b> .....	<b>41</b>
5.1 Theory of Operation.....	41
<b>6.0 Wiring Diagrams</b> .....	<b>45</b>
<b>7.0 Parts</b> .....	<b>49</b>
7.1 Ordering Code.....	49
7.2 Ordering Code.....	0
7.3 Legend Panel Replacement Ordering Code.....	50
7.4 Legend Panel Replacement.....	0
7.5 Parts Diagrams.....	51
7.6 Spare Parts.....	52
<b>A.0 SUPPORT</b> .....	<b>57</b>
A.1 ADB SAFEGATE Website.....	57
A.2 Recycling.....	58

A.2.1 Local Authority Recycling .....	58
A.2.2 ADB SAFEGATE Recycling .....	58

## List of Figures

Figure 1: Power Through Bottom - Remote Mounting (Preferred - Canada) .....	14
Figure 2: Power Through Leg - Remote Mounting (Preferred - FAA).....	15
Figure 3: Power Through Leg - Shallow Base Mounting (Alternate - FAA).....	16
Figure 4: Power Through Leg - Direct Mounting (Alternate - FAA) .....	17
Figure 5: Power Through Side Panel - Without Flexible Conduit (Not FAA Compliant) .....	17
Figure 6: Power Through Side Panel - Without Flexible Conduit (Not FAA Compliant) .....	18
Figure 7: L-823 Cord set and Extension Cords .....	19
Figure 8: 600 mm Signs with Standard Mounting Height Installation .....	20
Figure 9: 600 mm Signs with 48", 60", and 72" Mounting Height Installation .....	21
Figure 10: 800 mm Signs with Standard Mounting Height Installation .....	22
Figure 11: 800 mm Signs with 48", 60", and 72" Mounting Height Installation .....	23
Figure 12: 1200 mm Signs with Standard Mounting Height Installation .....	24
Figure 13: Two-hole (62A2142) and 4-hole (62A2146) Signs Couplings,.....	28
Figure 14: Sign Frangible Coupling.....	29
Figure 15: Series Wiring Isolation Transformer Installation .....	31
Figure 16: Installing Tether .....	32
Figure 17: Three Sizes of Light Bars .....	34
Figure 18: Single Power Supply Shunt Position.....	36
Figure 19: Sign Dual Power Supply Shunt Position.....	38
Figure 20: Bolt Torque Diagram .....	39
Figure 21: LED ICAO Sign, Single Power Supply and Light Engine Diagram .....	45
Figure 22: Detail B .....	45
Figure 23: LED ICAO Sign, Dual-Power Supply Diagram .....	47
Figure 24: LED ICAO Sign, Dual Power Supply Light Engine Diagram .....	48
Figure 25: Detail A .....	48
Figure 26: TP312/ICAO LED Sign Assembly Parts.....	51
Figure 27: ON/OFF Switch Protective Cover .....	52
Figure 28: Leg Extensions.....	56

## List of Tables

Table 1: Power Through Leg - Remote Mounting (Preferred - FAA) .....	15
Table 2: Power Through Leg - Shallow Base Mounting (Alternate - FAA) .....	16
Table 3: Power Through Leg - Direct Mounting (Alternate - FAA).....	17
Table 4: Power Through Side Panel - Without Flexible Conduit (Not FAA Compliant).....	18
Table 5: Power Through Side Panel - Without Flexible Conduit (Not FAA Compliant).....	18
Table 6: Cord set and Extension Cord Length .....	19
Table 7: Series Wiring Isolation Transformer Kits.....	30
Table 8: Preventative Maintenance Schedule .....	33
Table 9: Standard LED Signs .....	42
Table 10: Power Supply: LED Light Bar and Termination Chart.....	46
Table 11: Dual Power Supply: LED Light Bar and Termination Chart .....	48

Table 12: ICAO/TP312 LED Sign Spare Parts.....	53
Table 13: 600 mm Face - Standard Height Sign Coupling.....	54
Table 14: 600 mm FACE – 48"; 60"; 72" HEIGHT SIGN Coupling.....	54
Table 15: 800 mm Face - Standard Height Sign Couplings.....	55
Table 16: 800 mm Face - 48"; 60"; 72" Height Sign Couplings.....	55
Table 17: 1200 mm Face - Standard Height Sign Couplings.....	55
Table 18: Cordset Usage.....	56
Table 19: Cordsets.....	56

# 1.0 Safety

## Introduction to Safety







This section contains general safety instructions for installing and using ADB SAFEGATE equipment. Some safety instructions may not apply to the equipment in this manual. Task- and equipment-specific warnings are included in other sections of this manual where appropriate.

## 1.1 Safety Messages

### HAZARD Icons used in this manual

For all HAZARD symbols in use, see the Safety section. All symbols must comply with ISO and ANSI standards.

Carefully read and observe all safety instructions in this manual, which alert you to safety hazards and conditions that may result in personal injury, death or property and equipment damage and are accompanied by the symbols shown below.

	<p>WARNING</p> <p>Failure to observe a warning may result in personal injury, death or equipment damage.</p>
	<p>DANGER – Risk of electrical shock or ARC FLASH</p> <p>Disconnect equipment from line voltage. Failure to observe this warning may result in personal injury, death, or equipment damage. ARC Flash may cause blindness, severe burns or death.</p>
	<p>WARNING – Wear personal protective equipment</p> <p>Failure to observe may result in serious injury.</p>
	<p>WARNING – Do not touch</p> <p>Failure to observe this warning may result in personal injury, death, or equipment damage.</p>
	<p>CAUTION</p> <p>Failure to observe a caution may result in equipment damage.</p>
	<p>ELECTROSTATIC SENSITIVE DEVICES</p> <p>This equipment may contain electrostatic devices.</p>

### Qualified Personnel

	<p><b>Important Information</b></p> <p>The term <b>qualified personnel</b> is defined here as individuals who thoroughly understand the equipment and its safe operation, maintenance and repair. Qualified personnel are physically capable of performing the required tasks, familiar with all relevant safety rules and regulations and have been trained to safely install, operate, maintain and repair the equipment. It is the responsibility of the company operating this equipment to ensure that its personnel meet these requirements.</p> <p>Always use required personal protective equipment (PPE) and follow safe electrical work practice.</p>
---	---

## 1.1.1 Introduction to Safety



### CAUTION

#### Unsafe Equipment Use

This equipment may contain electrostatic devices, hazardous voltages and sharp edges on components

- Read installation instructions in their entirety before starting installation.
- Become familiar with the general safety instructions in this section of the manual before installing, operating, maintaining or repairing this equipment.
- Read and carefully follow the instructions throughout this manual for performing specific tasks and working with specific equipment.
- Make this manual available to personnel installing, operating, maintaining or repairing this equipment.
- Follow all applicable safety procedures required by your company, industry standards and government or other regulatory agencies.
- Install all electrical connections to local code.
- Use only electrical wire of sufficient gauge and insulation to handle the rated current demand. All wiring must meet local codes.
- Route electrical wiring along a protected path. Make sure they will not be damaged by moving equipment.
- Protect components from damage, wear, and harsh environment conditions.
- Allow ample room for maintenance, panel accessibility, and cover removal.
- Protect equipment with safety devices as specified by applicable safety regulations
- If safety devices must be removed for installation, install them immediately after the work is completed and check them for proper functioning prior to returning power to the circuit.

**Failure to follow these instructions can result in serious injury, death or equipment damage**

## Additional Reference Materials



#### Important Information

- IEC – International Standards and Conformity Assessment for all electrical, electronic and related technologies.
- IEC 60364 – Electrical Installations in Buildings.
- CSA – C22.2 No.180:13 (R2018), series isolating transformers for airport lighting.
- FAA Advisory: AC 150/5340-26 (current edition), Maintenance of Airport Visual Aid Facilities.
- Maintenance personnel must refer to the maintenance procedure described in the ICAO Airport Services Manual, Part 9.
- ANSI/NFPA 79, Electrical Standards for Metalworking Machine Tools.
- National and local electrical codes and standards.

## 1.1.2 Intended Use



### CAUTION

#### Use this equipment as intended by the manufacturer

This equipment is designed to perform a specific function, do not use this equipment for other purposes

- Using this equipment in ways other than described in this manual may result in personal injury, death or property and equipment damage. Use this equipment only as described in this manual.

**Failure to follow this instruction can result in serious injury or equipment damage**

### 1.1.3 Material Handling Precautions: Storage



#### CAUTION

##### Improper Storage

Store this equipment properly

- If equipment is to be stored prior to installation, it must be protected from the weather elements and kept free of condensation and dust.

**Failure to follow this instruction can result in equipment damage**

### 1.1.4 Material Handling: Heavy Equipment



#### DANGER

##### UNSTABLE LOAD

USE CAUTION WHEN MOVING HEAVY EQUIPMENT

- USE EXTREME CARE WHEN MOVING HEAVY EQUIPMENT.
- VERIFY THAT THE MOVING EQUIPMENT IS RATED TO HANDLE THE WEIGHT.
- WHEN REMOVING EQUIPMENT FROM A SHIPPING PALLET, CAREFULLY BALANCE AND SECURE IT USING A SAFETY STRAP.

**FAILURE TO FOLLOW THIS INSTRUCTION CAN RESULT IN DEATH, SERIOUS INJURY, OR EQUIPMENT DAMAGE**

### 1.1.5 Operation Safety



#### CAUTION

##### Improper Operation

Do Not Operate this equipment other than as specified by the manufacturer

- Only qualified personnel, physically capable of operating the equipment and with no impairments in their judgment or reaction times, should operate this equipment.
- Read all system component manuals before operating this equipment. A thorough understanding of system components and their operation will help you operate the system safely and efficiently.
- Before starting this equipment, check all safety interlocks, fire-detection systems, and protective devices such as panels and covers. Make sure all devices are fully functional. Do not operate the system if these devices are not working properly. Do not deactivate or bypass automatic safety interlocks or locked-out electrical disconnects or pneumatic valves.
- Protect equipment with safety devices as specified by applicable safety regulations.
- If safety devices must be removed for installation, install them immediately after the work is completed and check them for proper functioning.
- Route electrical wiring along a protected path. Make sure they will not be damaged by moving equipment.
- Never operate equipment with a known malfunction.
- Do not attempt to operate or service electrical equipment if standing water is present.
- Use this equipment only in the environments for which it is rated. Do not operate this equipment in humid, flammable, or explosive environments unless it has been rated for safe operation in these environments.
- Never touch exposed electrical connections on equipment while the power is ON.

**Failure to follow these instructions can result in serious injury, death or equipment damage.**

## 1.1.6 Maintenance Safety



### **DANGER**

#### **ELECTRIC SHOCK HAZARD**

THIS EQUIPMENT MAY CONTAIN ELECTROSTATIC DEVICES

- DO NOT OPERATE A SYSTEM THAT CONTAINS MALFUNCTIONING COMPONENTS. IF A COMPONENT MALFUNCTIONS, TURN THE SYSTEM OFF IMMEDIATELY.
- DISCONNECT AND LOCK OUT ELECTRICAL POWER.
- ALLOW ONLY QUALIFIED PERSONNEL TO MAKE REPAIRS OR REPLACE MALFUNCTIONING COMPONENTS ACCORDING TO INSTRUCTIONS PROVIDED IN MANUAL.

**FAILURE TO FOLLOW THESE INSTRUCTIONS CAN RESULT IN DEATH OR EQUIPMENT DAMAGE**

## 1.1.7 Material Handling Precautions, ESD



### **CAUTION**

#### **Electrostatic Sensitive Devices**

This equipment may contain electrostatic devices

- Protect from electrostatic discharge.
- Electronic modules and components should be touched only when this is unavoidable e.g. soldering, replacement.
- Before touching any component of the cabinet you shall bring your body to the same potential as the cabinet by touching a conductive earthed part of the cabinet.
- Electronic modules or components must not be brought in contact with highly insulating materials such as plastic sheets, synthetic fiber clothing. They must be laid down on conductive surfaces.
- The tip of the soldering iron must be grounded.
- Electronic modules and components must be stored and transported in conductive packing.

**Failure to follow this instruction can result in equipment damage**

## 1.1.8 Arc Flash and Electric Shock Hazard



### **DANGER**

#### **SERIES CIRCUITS HAVE HAZARDOUS VOLTAGES**

THIS EQUIPMENT PRODUCES HIGH VOLTAGES TO MAINTAIN THE SPECIFIED CURRENT - DO NOT DISCONNECT WHILE ENERGIZED.

- ALLOW ONLY QUALIFIED PERSONNEL TO PERFORM MAINTENANCE, TROUBLESHOOTING, AND REPAIR TASKS.
- ONLY PERSONS WHO ARE PROPERLY TRAINED AND FAMILIAR WITH ADB SAFEGATE EQUIPMENT ARE PERMITTED TO SERVICE THIS EQUIPMENT.
- AN OPEN AIRFIELD CURRENT CIRCUIT IS CAPABLE OF GENERATING >5000 VAC AND MAY APPEAR OFF TO A METER.
- NEVER UNPLUG A DEVICE FROM A CONSTANT CURRENT CIRCUIT WHILE IT IS OPERATING; ARC FLASH MAY RESULT.
- DISCONNECT AND LOCK OUT ELECTRICAL POWER.
- ALWAYS USE SAFETY DEVICES WHEN WORKING ON THIS EQUIPMENT.
- FOLLOW THE RECOMMENDED MAINTENANCE PROCEDURES IN THE PRODUCT MANUALS.
- DO NOT SERVICE OR ADJUST ANY EQUIPMENT UNLESS ANOTHER PERSON TRAINED IN FIRST AID AND CPR IS PRESENT.
- CONNECT ALL DISCONNECTED EQUIPMENT GROUND CABLES AND WIRES AFTER SERVICING EQUIPMENT. GROUND ALL CONDUCTIVE EQUIPMENT.
- USE ONLY APPROVED ADB SAFEGATE REPLACEMENT PARTS. USING UNAPPROVED PARTS OR MAKING UNAPPROVED MODIFICATIONS TO EQUIPMENT MAY VOID AGENCY APPROVALS AND CREATE SAFETY HAZARDS.
- CHECK THE INTERLOCK SYSTEMS PERIODICALLY TO ENSURE THEIR EFFECTIVENESS.
- DO NOT ATTEMPT TO SERVICE ELECTRICAL EQUIPMENT IF STANDING WATER IS PRESENT. USE CAUTION WHEN SERVICING ELECTRICAL EQUIPMENT IN A HIGH-HUMIDITY ENVIRONMENT.
- USE TOOLS WITH INSULATED HANDLES WHEN WORKING WITH AIRFIELD ELECTRICAL EQUIPMENT.

**FAILURE TO FOLLOW THESE INSTRUCTIONS CAN RESULT IN DEATH OR EQUIPMENT DAMAGE**



## 2.0 Introduction

These signs are designed to guide pilots to a particular point on the field, identify holding positions, identify taxiway and runway intersections, and prohibit aircraft entry into designated areas.



## 2.1 LED Light Bar Airfield Guidance Sign

### Compliance with Standards

ICAO:	Annex 14, Volume I
Canada:	TP 312

### Uses

Illuminated airfield guidance signs are used as information, mandatory instruction, position and direction indicators in accordance with ICAO Annex 14, Section 5.4 Signs. The signs are available with 322 km/h wind load compliance.

#### Information Sign

Informational Direction, Destination, Boundary, and VOR Check-Point signs - black inscription on a yellow background. Designed to guide pilots to a particular point on the airfield by identifying runway exits, taxiway directions, taxiway intersections, taxiway ending, and inbound/outbound destinations, boundaries.

#### Mandatory signs

Mandatory Instruction sign - white inscription on a red background. Designed to identify holding positions, runway intersections, and prohibit aircraft entry into designated areas.

#### Location Sign

Runway and Taxiway Location signs - yellow inscription on a black background and only where it is a stand-alone sign shall have a yellow border. Designed to identify taxiway and runway location on which the aircraft is located.

#### Runway Distance Remaining signs

White inscription on a black background. Designed to provide runway distance remaining information to pilots during takeoff and landing operations. Inscriptions are descending numerals used at 1,000-foot intervals adjacent to the runway edge. Also available as an Illuminated Arrestor Cable Marker (IACM) sign.

### Operating Conditions

The taxiway and runway signs are designed for continuous outdoor use under the conditions presented below for operating temperature range, humidity, and wind.

Temperature:	-55 °F to +131 °F (-55 °C to +55 °C)
Humidity:	0 to 100%
Wind:	ADB SAFEGATE standard signs withstand a wind loading of 322 km/h (200 mph) and break before the wind loading reaches 480 km/h (300 mph).

### Features

- Unique LED light bar design maximizes energy efficiency

- Available battery-powered tester provides for quick and easy testing of individual LED light bars
- Electrical design uses a minimal number of components which maximizes sign MTBF and greatly simplifies troubleshooting efforts
- Virtually eliminates runway and taxiway shutdowns due to long-lasting LED light source
- Creates a highly uniform distribution of light, eliminating hot spots and shadows
- Operates on ferroresonant or thyristor CCRs that are designed in compliance with FAA or IEC requirements
- Operates on all steps of a 3-step or 5-step CCR and on a 1-step CCR
- Exceeds latest ICAO and TP 312 requirements for Chromaticity
- Maintains constant luminosity at maximum brightness on all CCR steps
- Improved safety with regulated low DC voltage inside sign
- Eliminates re-lamp expenses and reduces on-going maintenance cost
- Modular construction: commonality of mechanical and electrical components throughout entire sign range
- Low mass, frangible, rigid construction of aluminum frame extrusions
- Protection class: IP 54

### **Electrical Supply**

Signs are internally lighted. The signs are connected to a series circuit using the appropriately-sized 50 or 60 Hz isolation transformer.

### **Construction**

Corrosion-resistant sign construction requires minimal maintenance. The sign uses aluminum housing, stainless steel hardware, and translucent acrylic legend panels.

## Sign Dimensions - Standard Mounting Height Shown - inch(mm)

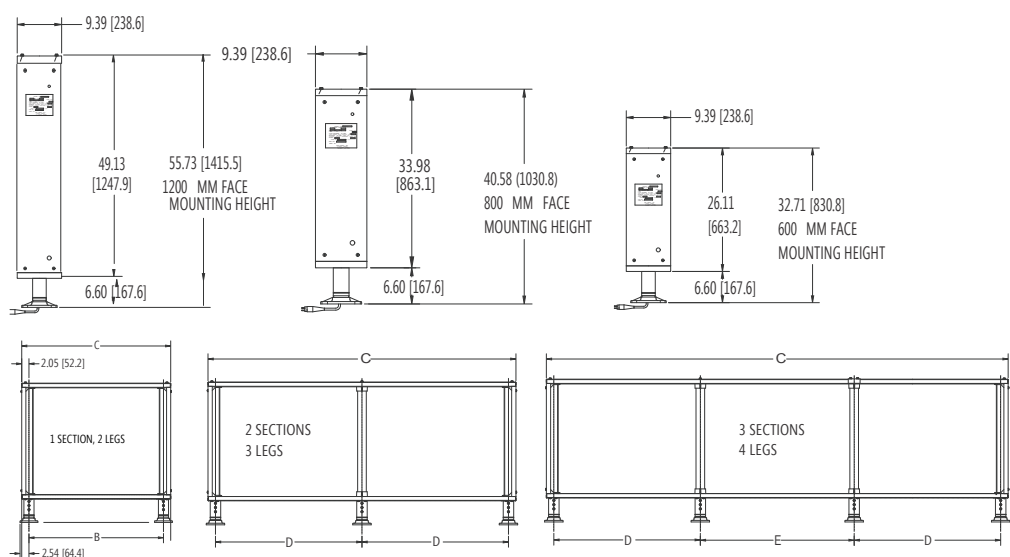

Sign Type	Illuminated Face Length	B	C	D	E
<b>1 Section, 2 Legs</b>					
SBXA	700 mm	655.3 (25.90)	759.7 (29.92)	NA	NA
SBXB	900 mm	855.5 (33.68)	959.9 (37.79)	NA	NA
SBXC	1100 mm	1055.4 (41.55)	1159.8 (45.66)	NA	NA
SBXD	1300 mm	1255.3 (49.42)	1359.7 (53.53)	NA	NA
SBXE	1500 mm	1455.4 (57.30)	1559.8 (61.41)	NA	NA
<b>2 Section, 3 Legs</b>					
SBXF	1700 mm	NA	1759.7 (69.28)	827.7 (32.59)	NA
SBXG	1900 mm	NA	1959.7 (77.16)	927.7 (36.53)	NA
SBXH	2100 mm	NA	2159.7 (85.03)	1027.7 (40.26)	NA
SBXJ	2300 mm	NA	2359.7 (92.90)	1127.7 (44.40)	NA
SBXK	2500 mm	NA	2559.7 (100.78)	1227.7 (48.34)	NA
SBXL	2700 mm	NA	2759.7 (108.65)	1327.7 (52.27)	NA
SBXM	2900 mm	NA	2959.7 (116.53)	1427.7 (56.21)	NA
SBKQ	1200 mm	NA	1215.1 (47.84)	555.5 (21.87)	NA
<b>3 Section, 4 Legs</b>					
SBXN	3300 mm	NA	3359.7 (132.27)	1077.7 (42.43)	1100.0 (43.31)
SBXP	3700 mm	NA	3636.5 (143.17)	1277.7 (50.30)	1100.0 (43.31)

## Electrical Supply

Signs are internally lighted and are connected to a series circuit using the appropriately-sized 50 or 60 Hz L-830/L-831 isolation transformer.

## Sign Load & Transformer Requirements

Sign Type	Sign Length	1-Step (5.5A)			3-Step (4.8-6.6A)			5-Step (2.8-6.6A)		
		Transformer	Power Factor	VA	Transformer	Power Factor	VA	Transformer	Power Factor	VA
SBXA	700	200 W	0.89	124	300 W	0.87	150	300 W	0.85	151
SBXB	900	300 W	0.87	135	300 W	0.86	168	300 W	0.84	168
SBXC	1100	300 W	0.82	103	300 W	0.87	118	300 W	0.83	119
SBXD	1300	300 W	0.88	121	300 W	0.88	132	300 W	0.84	134
SBXE	1500	300 W	0.87	135	300 W	0.84	150	300 W	0.84	148
SBXF	1700	300 W	0.87	135	300 W	0.84	150	300 W	0.84	148
SBXG	1900	300 W	0.87	135	300 W	0.84	150	300 W	0.84	148
SBXH	2100	300 W	0.88	168	300 W	0.87	180	500 W	0.84	184
SBXJ	2300	300 W	0.88	168	300 W	0.87	180	500 W	0.84	184
SBXK	2500	300 W	0.89	220	500 W	0.88	241	(2)300 W	0.84	261
SBXL	2700	300 W	0.89	220	500 W	0.88	241	(2)300 W	0.84	261
SBXM	2900	500 W	0.89	255	(2)300 W	0.88	295	(2)300 W	0.84	291
SBXN	3300	500 W	0.89	255	(2)300 W	0.88	295	(2)300 W	0.84	291
SBXP	3700	500 W	0.89	252	(2)300 W	0.88	289	(2)500 W	0.84	299
SBKQ	1200	300 W	0.91	162	300 W	0.90	174	500 W	0.91	174



### Note

- In the table above, the number for the total VA load imposed on the CCR represents the actual load imposed on the regulator and accounts for power factor and load imposed by the transformer. For signs that require two transformers a wye connector 94A0173 (ordered separately) is required to connect the transformers in series. Load data are estimates for worst case scenario.

## Packaging Data (600 mm Signs)

Signs are shipped with L-823 cord set(s), frangible couplings, and mounting flanges - ready for installation.

Sign Type	Gross Assembled Weight								Carton Dimensions (h × w × d)	
	SB6X Standard Height		SBDX 1219 mm (48")		SBEX <sup>1</sup> 1524 mm (60")		SBFX <sup>1</sup> 1829 mm (72")			
	(lb)	(kg)	(lb)	(kg)	(lb)	(kg)	(lb)	(kg)	(in)	(mm)
SBXA	64	29.0	69	31.3	75	34.0	79	35.8	36 × 37 × 13	914 × 950 × 330
SBXB	72	32.6	77	34.9	83	37.6	87	39.5	36 × 45 × 13	914 × 1150 × 330
SBXC	80	36.3	85	38.5	91	41.3	95	43.1	36 × 53 × 13	914 × 1350 × 330
SBXD	88	39.9	93	42.2	99	44.9	103	46.7	36 × 61 × 13	914 × 1550 × 330
SBXE	97	44.0	102	46.3	108	49.0	112	50.8	36 × 70 × 13	914 × 1750 × 330
SBXF	122	55.3	130	59.0	138	62.6	145	65.8	36 × 77 × 13	914 × 1950 × 330
SBXG	130	59.0	138	62.6	146	66.2	153	69.4	36 × 85 × 13	914 × 2150 × 330
SBXH	138	62.6	146	66.2	154	69.8	161	73.0	36 × 93 × 13	914 × 2350 × 330
SBXJ	146	66.2	154	68.9	162	73.5	169	76.6	36 × 100 × 13	914 × 2550 × 330
SBXK	153	69.4	161	73.0	169	76.6	176	79.8	36 × 108 × 13	914 × 2750 × 330
SBXL	161	73.0	169	76.6	177	80.3	184	83.5	36 × 116 × 13	914 × 2950 × 330
SBXM	169	76.6	177	80.3	185	83.9	192	87.1	36 × 124 × 13	914 × 3150 × 330
SBXN	203	92.1	213	96.6	225	102.0	233	101.1	36 × 140 × 13	914 × 3550 × 330
SBXP	220	99.8	230	104.3	242	109.8	250	113.4	36 × 156 × 13	914 × 3950 × 330



### Note

- 1219 mm (48 in) signs ship as 1295 mm (51 in) height.
- 1524 mm (60 in) and 1829 mm (72 in) signs ship as standard height.

<sup>1</sup>Shipped same carton size as standard height; legs enclosed separately; requires assembly.

### Packaging Data (800 mm Signs)

Signs are shipped with L-823 cord set(s), frangible couplings, and mounting flanges - ready for installation.

Sign Type	Gross Assembled Weight								Carton Dimensions (h × w × d)	
	SB8X Standard Height		SBGX 1219 mm (48")		SBHX <sup>1</sup> 1524 mm (60")		SBJX <sup>1</sup> 1829 mm (72")		(in)	(mm)
	(lb)	(kg)	(lb)	(kg)	(lb)	(kg)	(lb)	(kg)		
SBXA	72	32.6	77	34.9	83	37.6	87	39.5	43.5 X 37 X 13	1105 X 960 X 330
SBXB	82	37.0	87	39.5	93	42.2	97	44.0	43.5 X 45 X 13	1105 X 1150 X 330
SBXC	94	42.6	99	44.9	105	47.6	109	49.4	43.5 X 53 X 13	1105 X 1350 X 330
SBXD	104	47.0	109	49.4	115	52.2	119	54	43.5 X 61 X 13	1105 X 1550 X 330
SBXE	114	51.7	119	54.0	125	56.7	129	58.5	43.5 X 70 X 13	1105 X 1750 X 330
SBXF	136	61.7	144	65.3	152	68.9	159	72.1	43.5 X 77 X 13	1105 X 1950 X 330
SBXG	149	67.6	157	71.2	165	74.8	172	78.0	43.5 X 85 X 13	1105 X 2150 X 330
SBXH	161	73.0	169	76.7	177	80.3	184	83.5	43.5 X 93 X 13	1105 X 2350 X 330
SBXJ	173	78.5	181	82.1	189	85.7	196	88.9	43.5 X 100 X 13	1105 X 2550 X 330
SBXK	182	82.5	190	86.2	198	89.8	205	93.0	43.5 X 108 X 13	1105 X 2750 X 330
SBXL	193	87.5	201	91.2	209	94.8	216	98.0	43.5 X 116 X 13	1105 X 2950 X 330
SBXM	205	93.0	213	96.6	221	100.2	228	103.4	43.5 X 124 X 13	1105 X 3150 X 330
SBXN	242	110.0	252	114.3	264	119.7	272	123.4	43.5 X 140 X 13	1105 X 3550 X 330
SBXP	265	120.2	275	124.7	287	130.2	294	133.4	43.5 X 156 X 13	1105 X 3950 X 330



### Note

- 1219 mm (48 in) signs ship as 1295 mm (51 in) height.
- 1524 mm (60 in) and 1829 mm (72 in) signs ship as standard height.

### Packaging Data (1200 mm Signs)

Signs are shipped with L-823 cord set(s), frangible couplings, and mounting flanges - ready for installation.

Sign Type	Gross Assembled Weight			
	Standard Height		Carton Dimensions (h × w × d)	
	(lb)	(kg)	(in)	(mm)
SBKQ	122	56.0	62x52x13	158x132x33

## 3.0 Installation



### WARNING

Read installation instructions in their entirety before starting installation.

- Read and carefully follow the instructions throughout this manual for performing specific tasks and working with specific equipment.
- Follow all applicable safety procedures required by your company, industry standards and government or other regulatory agencies.
- Install all electrical connections to local code.
- Use only electrical wire of sufficient gauge and insulation to handle the rated current demand. All wiring must meet local codes.
- Protect equipment with safety devices as specified by applicable safety regulations.
- If safety devices must be removed for installation, install them immediately after the work is completed and check them for proper functioning prior to returning power to the circuit.

**Failure to follow these warnings may result in serious injury or equipment damage.**

Each sign is furnished complete with mounting flanges for installation on a concrete pad, or on a transition plate (typically used for Canadian applications), contact the ADB SAFEGATE sales department for more details. Contact the ADB SAFEGATE Sales Department for more information on sign installation hardware.

This section provides instructions for installing L-858 taxiway and runway signs. Refer to the airport project plans and specifications for the specific installation instructions.

## 3.1 Unpacking

The equipment is shipped ready for installation. Handle equipment very carefully to prevent component damage. Unpack the carton upon receipt and check the contents and their condition. Note any exterior damage to the carton that might lead to detection of equipment damage.

If you note any damage to any equipment, file a claim with the carrier immediately. The carrier may need to inspect the equipment.

## 3.2 Power Entry and Mounting Configurations

This section provides information on a variety of power entry and mounting configurations available with the AGSB-L sign.

Power entry and mounting configurations vary in TP312 and ICAO markets. This section provides examples and guidance for installation. However, all local regulatory requirements should be considered when installing the AGSB-L sign.

Some of the configurations shown derive from FAA requirements, which may not be applicable to your market. The FAA specifies there must be no above ground power cable connections to signs, and power to a sign or sign array must be provided through breakaway cable connectors installed within the frangible point portion of the sign's mounting legs.

### 3.2.1 Power Through Bottom - Remote Mounting (Preferred - Canada)

Figure 1 shows details for installations with power through the bottom with remote mounting. This is the preferred mounting configuration for airfield guidance signs in Canada.

Figure 1: Power Through Bottom - Remote Mounting (Preferred - Canada)

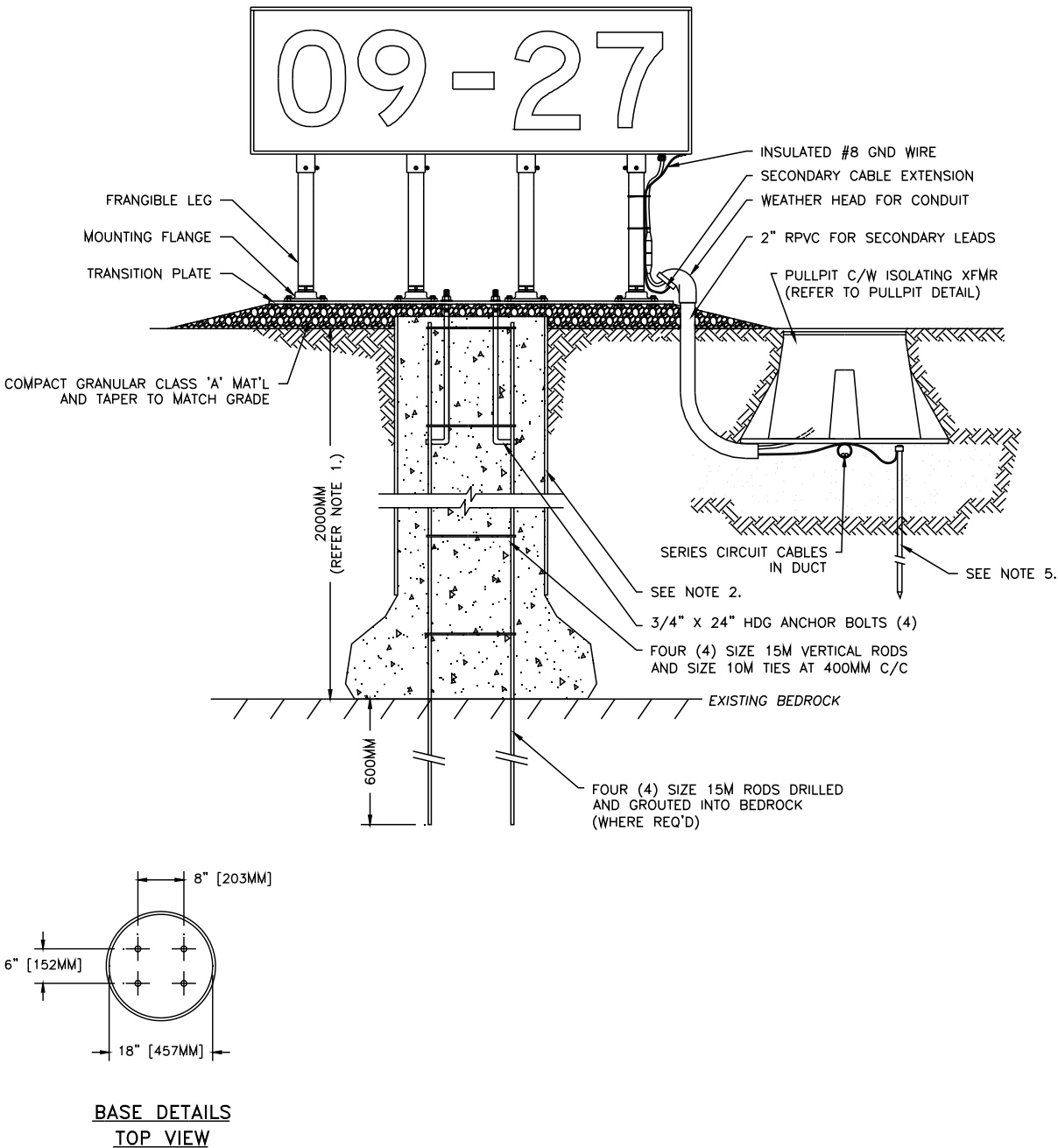

Notes:

1. Minimum base depth in stable soils is 200 mm. If bedrock is encountered, install the tie-in as shown. If soil is unstable, excavate to bedrock and tie-in as shown.
2. 450 mm diameter sonotube to be 300 mm shorter than depth of excavation. Wrap sonotube with double layer of 6 mil. polyethylene vapour barrier and tape in place. Repeat with a second wrap.
3. Alternate base designs may be acceptable. Consult civil engineer regarding site conditions.
4. Apply generous amounts of anti-sieze compound to all threaded joints. Run insulated ground wire from power converter chassis to 19 mm x 4 m ground rodpo beneath pullpit. Do not connect this ground to counterpoise wire.
5. Number of bases required depends on sign length. Refer to project drawings for details.

### 3.2.2 Power Through Leg - Remote Mounting (Preferred - FAA)

Figure 2 shows details for installations with power through the leg with remote mounting. This is the preferred mounting configuration for airfield guidance signs. Refer to Table 1 for parts and information.

Figure 2: Power Through Leg - Remote Mounting (Preferred - FAA)

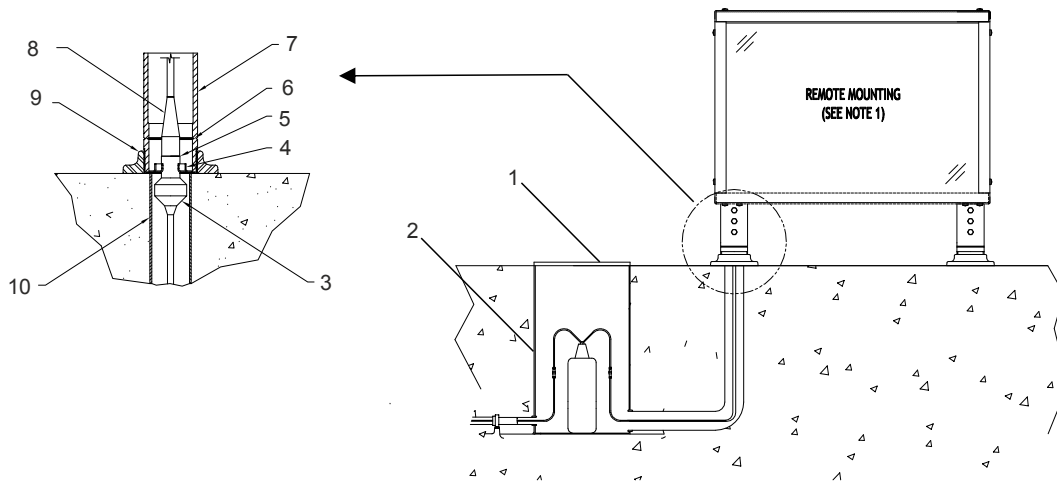

Table 1: Power Through Leg - Remote Mounting (Preferred - FAA)

Item	Description	Part Number	Note
1	L-867B blank cover, 3/8 in thick	Contact ADB SAFEGATE	Ordered separately
2	L-867B base can	Contact ADB SAFEGATE	Ordered separately
3	L-823 Extension cord (style 1, style 7)	73A0108/X	X is length in feet 8ft (2.4 m) is the typical length used
4	Cable clamp	60A2851	Ordered separately
5	End of 73A0108/X must be located at +0/-1 in from coupling frangible point		
6	Frangible point on coupling		
7	Frangible coupling	60A2678/XX	Supplied with sign
8	L-823 cordset	73A0107/72	Supplied with sign
9	Mounting flange	62A2142	Supplied with sign
10	2-inch conduit Top to be flush with top surface of concrete pad		

### 3.2.3 Power Through Leg - Shallow Base Mounting (Alternate - FAA)

Figure 3 shows detail for installations with power through the leg in the case of shallow base remote mounting. This is a preferred alternative mounting configuration for airfield guidance signs. Refer to Table 2 for parts and information.

**Figure 3: Power Through Leg - Shallow Base Mounting (Alternate - FAA)**

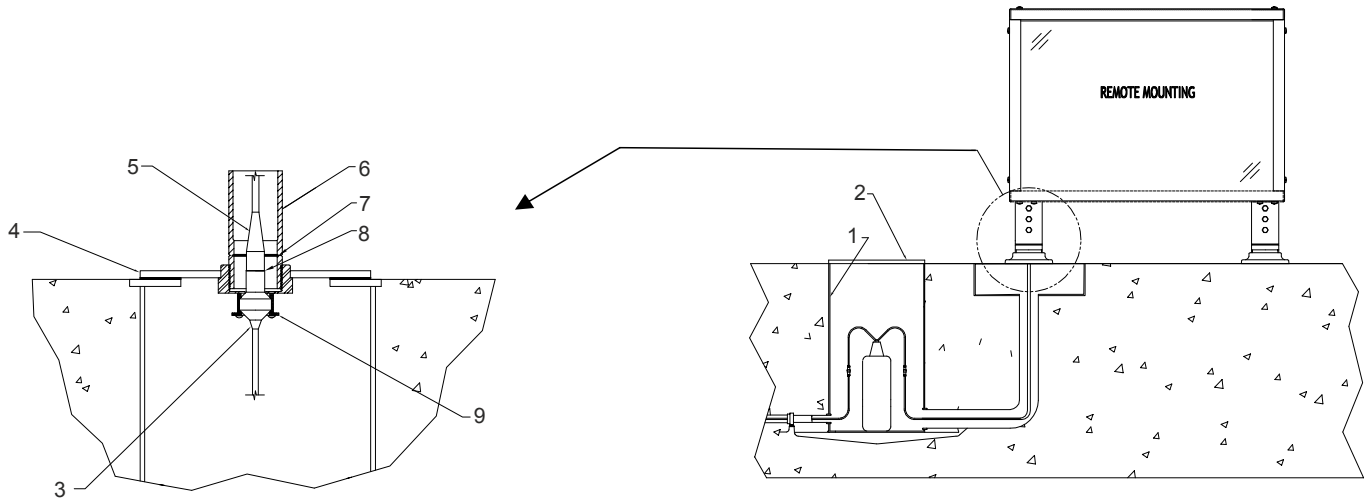

**Table 2: Power Through Leg - Shallow Base Mounting (Alternate - FAA)**

Item	Description	Part Number	Note
1	L-867B base can	Contact ADB SAFEGATE	Ordered separately
2	L-867B blank base plate, 3/8 in thick with gasket	Contact ADB SAFEGATE	Ordered separately
3	L-823 Extension cord (style 1, style 8)	73A0109/X	X is length in feet, 8ft (2.4 m) is the typical length used.
4	L-867B heavy base plate, 3/8 in thick with gasket, 2 1/2-8 NPS hub	1832BSPLT	Ordered separately
5	L-823 cordset	73A0107/72	Supplied with sign
6	Frangible coupling	60A2678/XX	Supplied with sign
7	Frangible point on coupling		
8	End of 73A0109/X must be located at +0/-1 in from coupling frangible point		
9	Cable clamp		Supplied with base plate



**Note**

Remove the sign flange provided with the sign and screw the frangible coupling directly into the 2-1/2" hub on the base plate.

**3.2.4 Power Through Leg - Direct Mounting (Alternate - FAA)**

Figure 4 shows details for installations with power through the leg with direct mounting onto a base plate. Refer to Table 3 for parts and information.

Figure 4: Power Through Leg - Direct Mounting (Alternate - FAA)

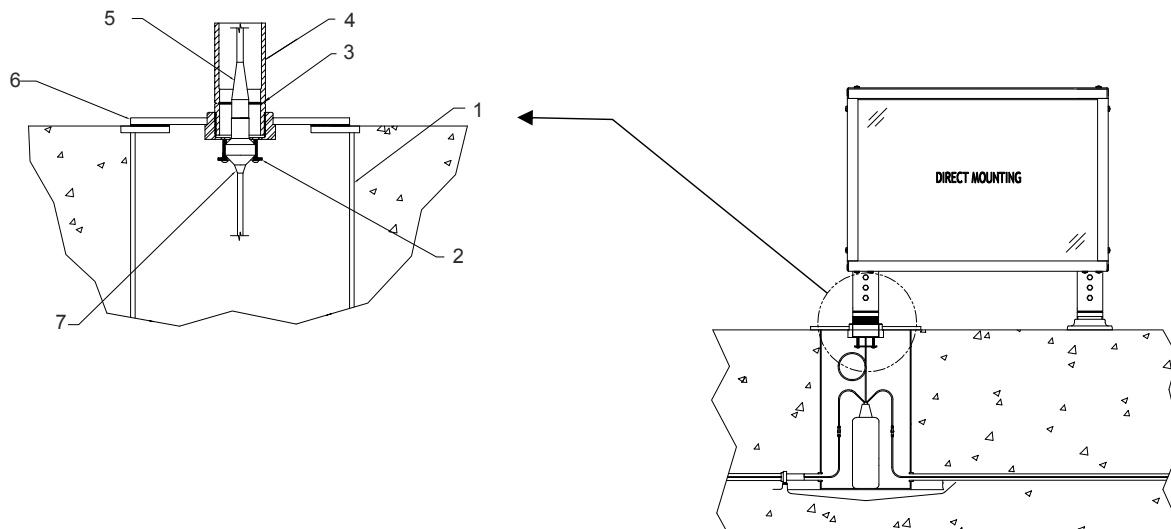

Table 3: Power Through Leg - Direct Mounting (Alternate - FAA)

Item	Description	Part Number	Note
1	L-867B base can	Contact ADB SAFEGATE	Ordered separately
2	Cable clamp		Supplied with base plate
3	Frangible point on coupling		
4	Frangible coupling	60A2678/XX	Supplied with sign
5	L-823 cordset	73A0107/72	Supplied with sign
6	L-867B heavy base plate, 3/8 in thick with gasket, 2 1/2-8 NPS hub	1832BSPLT	Ordered separately
7	Transformer secondary		



**Note**

Remove the sign flange provided with the sign and screw the frangible coupling directly into the 2-1/2" hub on the base plate.

### 3.2.5 Power Through Side Panel - Without Flexible Conduit (Not FAA Compliant)

Figure 5 shows details for installations with power entry through the side panel (without flexible conduit). Refer to Table 4 for parts and information.

Figure 5: Power Through Side Panel - Without Flexible Conduit (Not FAA Compliant)

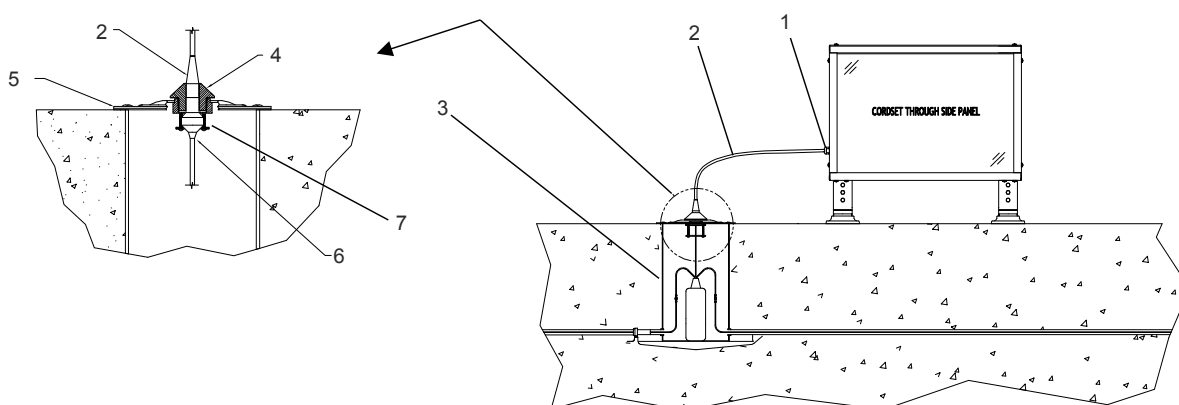

**Table 4: Power Through Side Panel - Without Flexible Conduit (Not FAA Compliant)**

Item	Description	Part Number	Note
1	Strain relief	77A0156 (Fitting) 77A0149 (Nut)	Supplied with sign
2	L-823 cord set	73A0107/72	Supplied with sign
3	L-867B base can	Contact ADB SAFEGATE	Ordered separately
4	Weather plug	63B0550	Ordered separately
5	L-867B base plate with gasket, 2-11.5 NPS hub	1932	Ordered separately
6	Transformer secondary		
7	Cable Clamp		Supplied with base plate

### 3.2.6 Power Through Side Panel - Without Flexible Conduit (Not FAA Compliant)

Figure 6 shows details for installations with power entry through the side panel (without flexible conduit). Refer to Table 5 for parts and information.

**Figure 6: Power Through Side Panel - Without Flexible Conduit (Not FAA Compliant)**

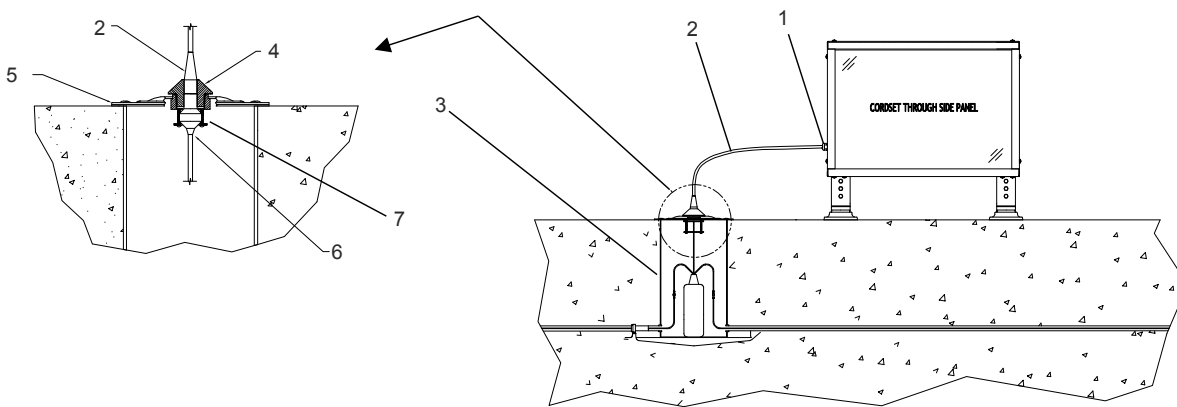

**Table 5: Power Through Side Panel - Without Flexible Conduit (Not FAA Compliant)**

Item	Description	Part Number	Note
1	Strain relief	77A0156 (Fitting) 77A0149 (Nut)	Supplied with sign
2	L-823 cord set	73A0107/72	Supplied with sign
3	L-867B base can	Contact ADB SAFEGATE	Ordered separately
4	Weather plug	63B0550	Ordered separately
5	L-867B base plate with gasket, 2-11.5 NPS hub	1932	Ordered separately
6	Transformer secondary		
7	Cable Clamp		Supplied with base plate

### 3.3 Cord sets and Extension Cords

This section provides information on L-823 cord sets and extension cords commonly used with the AGSF-L LED Airfield Guidance Sign. See Figure 7 and refer to Table 6 for cord set and extension cord types and part codes.

**Figure 7: L-823 Cord set and Extension Cords**

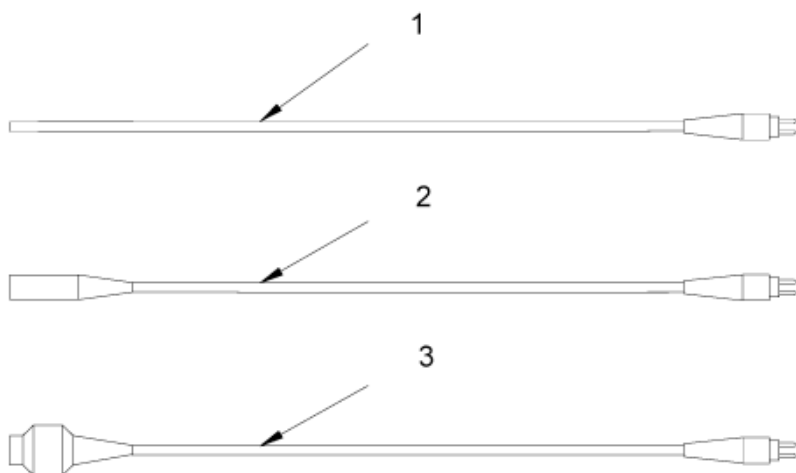

**Table 6: Cord set and Extension Cord Length**

Item	Receptacle Style	Plug Style	Description	Part Number
1	Bare wire	Type II, Class A, Style 1	L-823 cord set, 16/2 wire, 4 ft (1.2 m)	73A0107/48
			L-823 cord set, 16/2 wire, 6 ft (1.8 m)	73A0107/72
2	Type II, Class A, Style 7	Type II, Class A, Style 1	L-823 extension cord, 16/2 wire, 8 ft (2.4 m)	73A0108/8
3	Type II, Class A, Style 8	Type II, Class A, Style 1	L-823 extension cord, 16/2 wire, 8 ft (2.4 m)	73A0109/8

### 3.4 General Guidelines



#### WARNING

##### Equipment Damage

Read the safety instructions in their entirety before continuing.

- Signs must be grounded to a true earth ground. Failure to observe this warning may result in personal injury, death, or equipment damage.
- When installing signs, follow the guidelines covered in FAA AC 150/5340-30, Fig 126 for mounting pad design. Also see the following subsections for detailed information on sign pad and leveling of the sign.

**FAILURE TO INSTALL AND LEVEL THE SIGN AS DESCRIBED IN THE VARIOUS SUBSECTIONS BELOW WILL VOID THE WARRANTY.**

- Mount the signs on a concrete slab or concrete pedestals or a transition plate.
- Do not allow concrete edges to protrude above grade.
- The preferred method to connect power to the signs is through a breakaway cable connectors installed within the frangible coupling portion of the sign 's mounting legs.
- Install auxiliary equipment, such as isolation transformers, in a light base embedded in the ground or in a separate pull pit.

#### 3.4.1 Overall Mounting Height

Install signs so that the overall height above the surrounding ground of the sign assembly, including mounting supports, does not exceed heights given in ICAO Annex 14 or Transport Canada TP312. The sign must provide 12 inches (304.8 mm) of clearance between the top of the sign and any part of the most critical aircraft using, or expected to use, the airport when the aircraft's wheels are at the pavement edge.

### 3.4.2 Dimension Diagrams for Installation

Figure 8: 600 mm Signs with Standard Mounting Height Installation

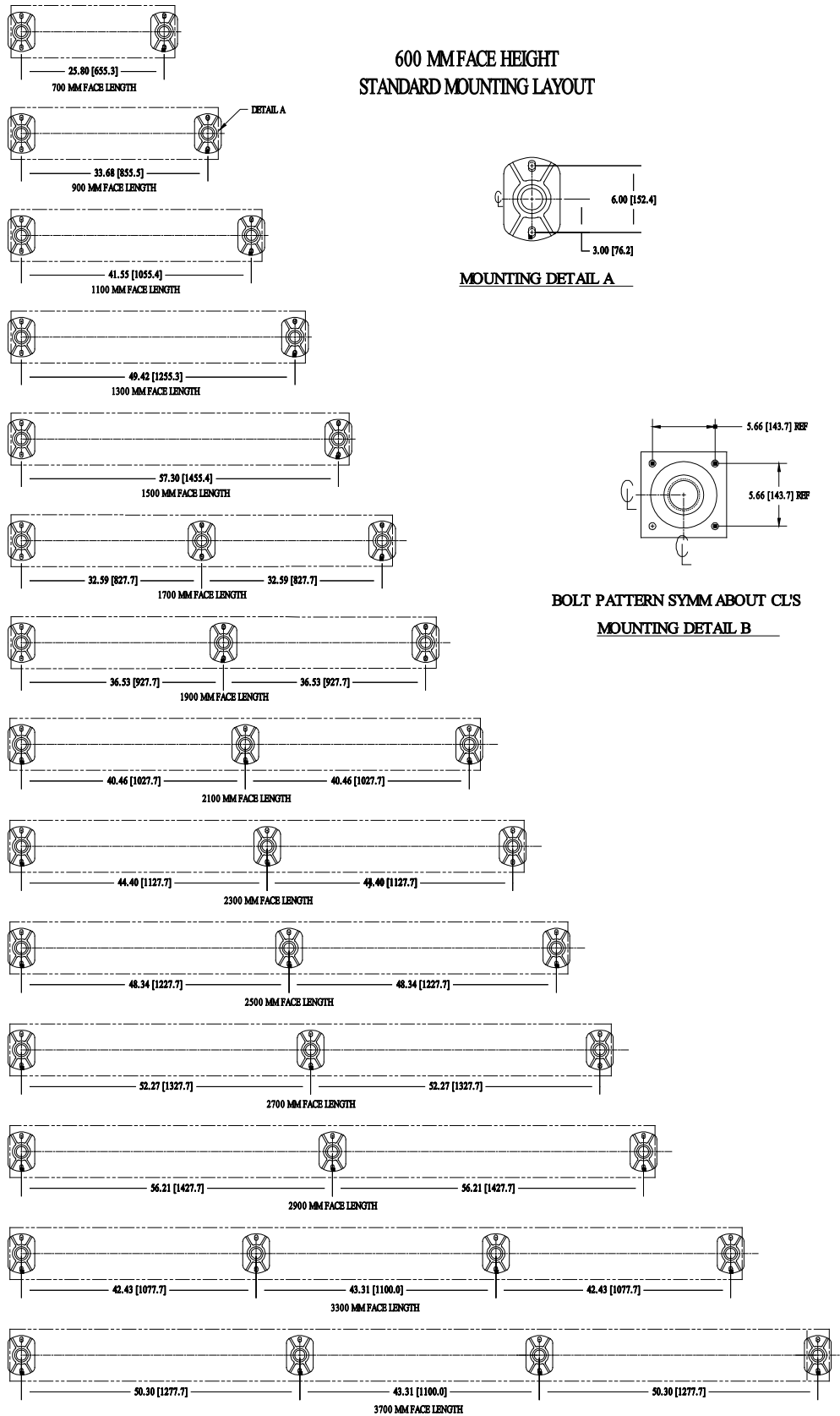

**Figure 9: 600 mm Signs with 48", 60", and 72" Mounting Height Installation**

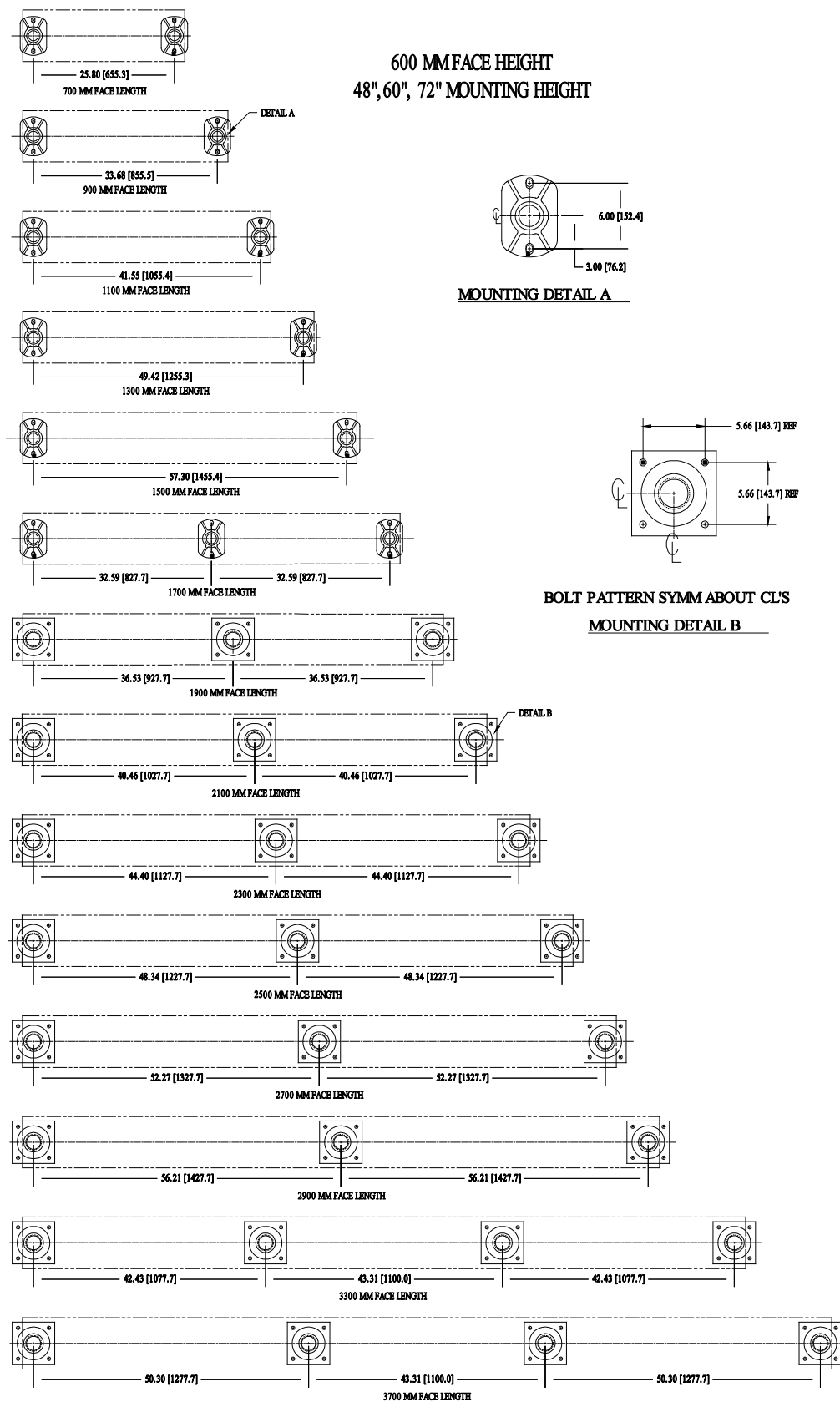

**Figure 10: 800 mm Signs with Standard Mounting Height Installation**

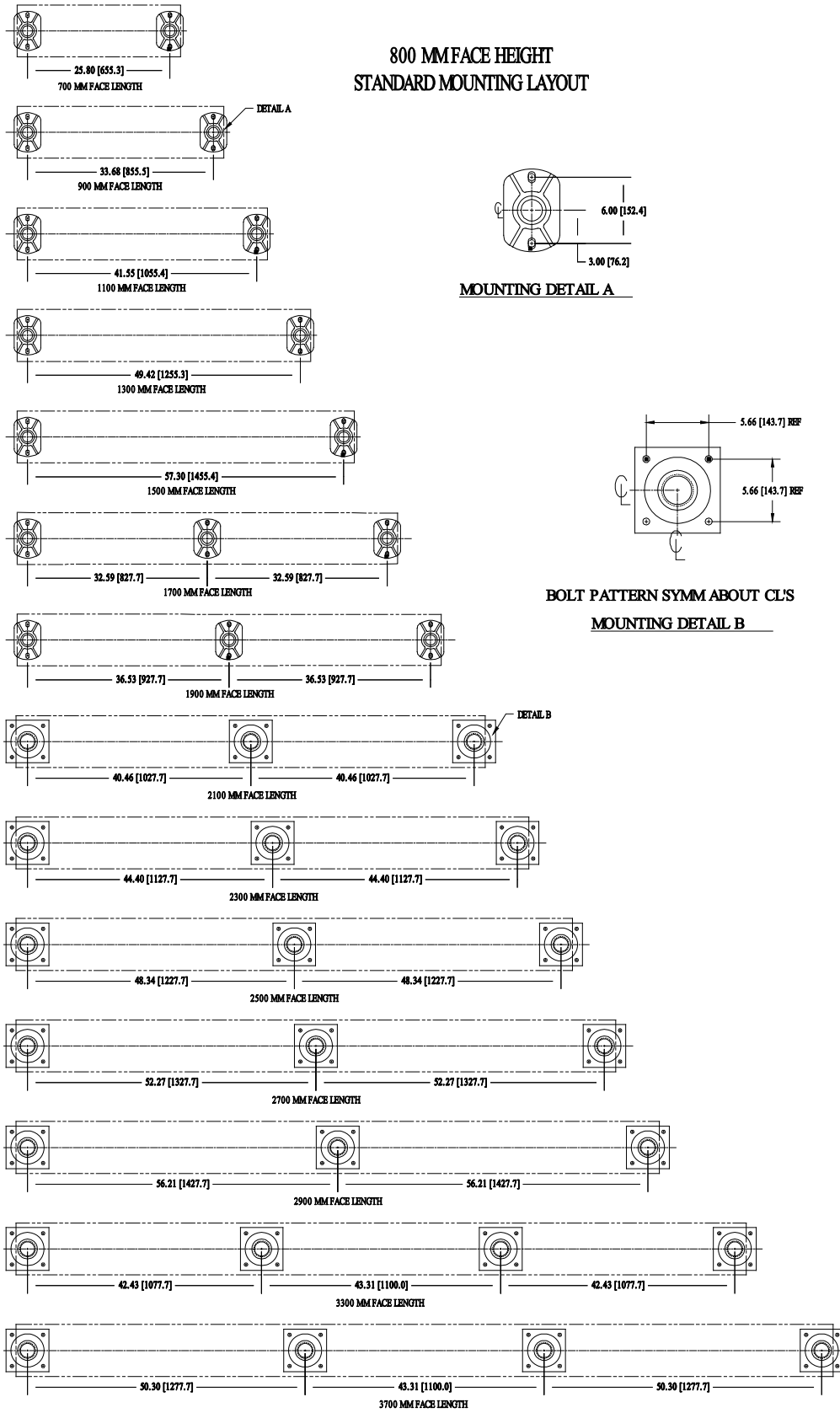
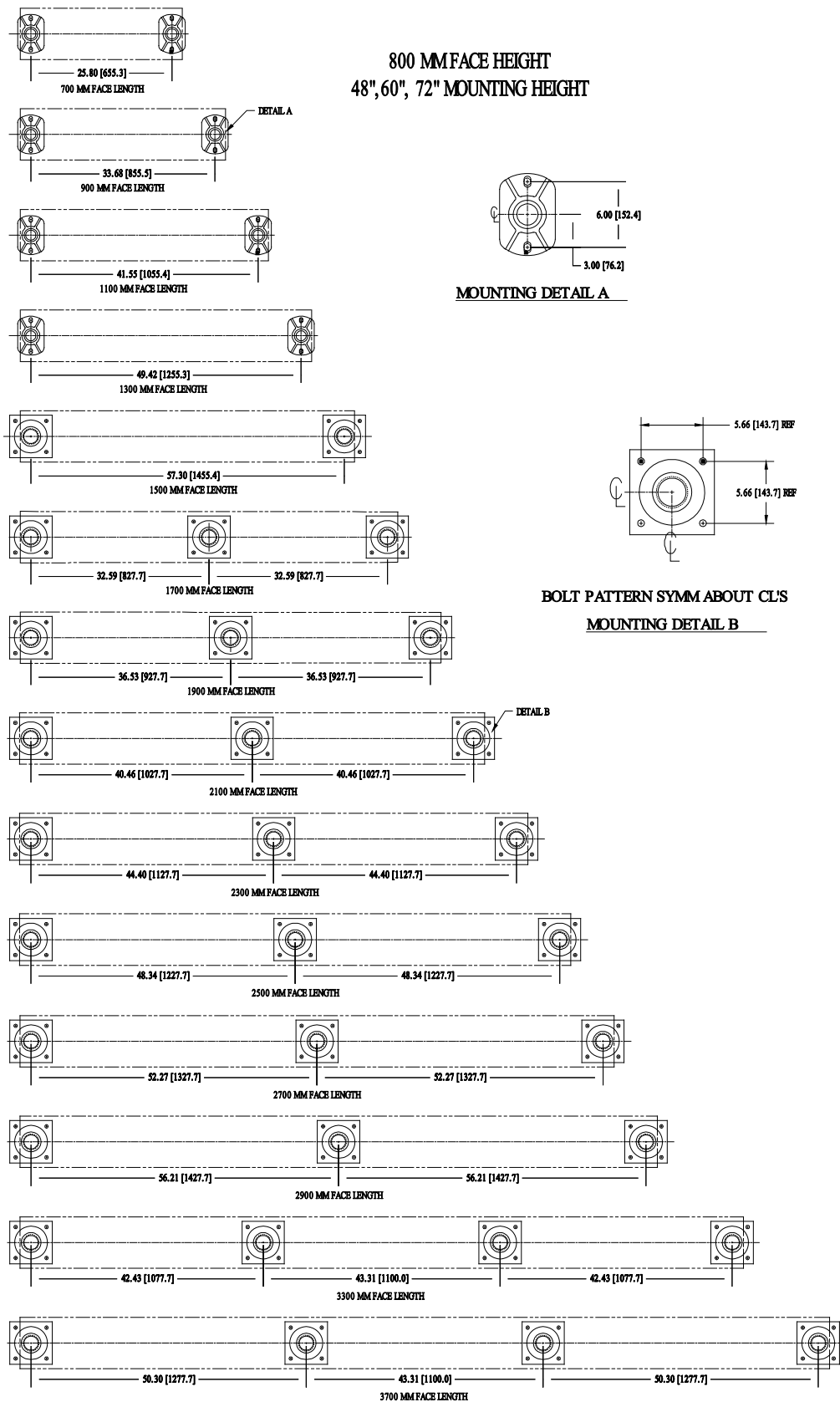
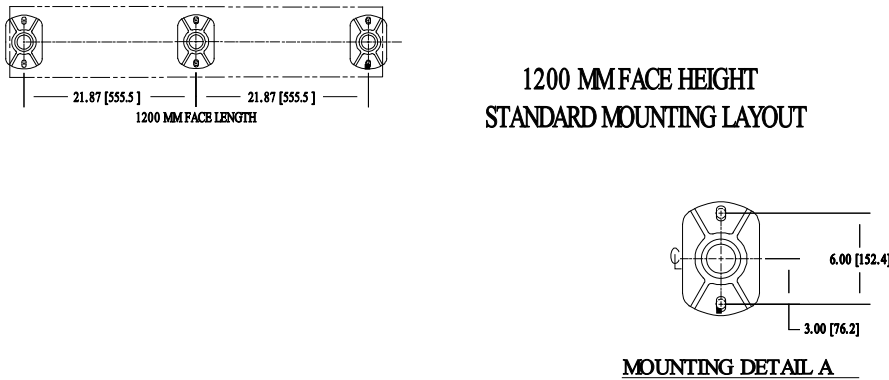

Figure 11: 800 mm Signs with 48", 60", and 72" Mounting Height Installation



**Figure 12: 1200 mm Signs with Standard Mounting Height Installation**



### 3.4.3 Sign Orientation

When orienting signs follow the guidelines below.

- Orient the sign so that the face is perpendicular to the centerline of the taxiway or runway.



#### Note

Check site plans and specifications for the location of the power leg (leg where the L-823 cord set is located) in reference to the L-867 light base. Typically, the L-867 light base is immediately under the power leg or is at the same end, but not under the power leg. ADB SAFEGATE signs are shipped with the sign product label attached to the sign end where the power leg is located. In addition, verify that the sign legend is orientated correctly to the taxiway or runway per the site plans when the sign is installed on the pad. If the sign legend location is not correct, then the panels must be removed and reinstalled in the sign in the correct location.

### 3.4.4 Sign Distance from Pavement Edge

Refer to ICAO Annex 14 or Transport Canada TP312 for information on the location of different types of taxiway signs.

#### ICAO

Table 5-4 of ICAO Annex 14, Volume I should serve as a basis for determining the location of the guidance signs.

This table gives the perpendicular distance from defined taxiway / runway pavement edge to near side of sign.

#### Location

Exact location and orientation have to be determined on site, jointly by the contractor and the project management and finally approved by the Airport Authority (generally the Ground Traffic Control Manager).

#### Other Considerations

Unobstructed sign legibility and protection from direct exhaust blast are other considerations to be taken into account as well.

### 3.4.5 Sign Installation on a Concrete Pad



#### Note

Follow site plans and specifications for concrete dimensions.

### 3.4.6 Concrete Pouring

See the site plans.

To pour a concrete pad, perform the following procedure:

1. Determine the sign size and overall length.
2. Pour your concrete pad according to the following requirements:
  - A minimum of 30 inches (762 mm) wide, extending a minimum of 6 inches (152.4 mm) beyond the end of the supports. The sign pad needs to be flat and level in the area where the sign mounting flanges are located. The mounting floor flange is nominally 5.0 wide x 7.50 long and the area beyond the flange can be tapered to the outside edge of the concrete pad to provide for pad drainage.
  - A minimum of 4 inches (101.6 mm) depth, extending below the frost line to prevent frost heave.
  - Reinforce according to site plans and specifications.

3. Install a minimum of one 12-inch (304.8 mm) L-867B power base (1) according to the following guidelines:

- Install the base close to the sign in or near the concrete pad to provide easy access to the isolation transformer.



### Note

When installing the base in the concrete pad, hold the L-867 base firmly in place during construction of the pad so that the upper surface of the base flange is level within  $\pm 2$  degrees and not more than 3/8 inch (9.525 mm) above the concrete surface.

- All other bearing surfaces on the pad for additional flange supports should be kept in the same horizontal plane as the L-867 base flange. The pad area where the sign mounting flanges will be located is to be flat **with no taper** to ensure that the sign will set level to prevent uneven loading on the frangible couplings.
- Refer to “Dimensions” for the base dimensions and the base flange used for each sign.

Before the concrete sets, install two 1/2-13 anchor bolts into the concrete pad. The bolt hole centerline is on a 6-inch (152.4 mm) diameter bolt circle, 180 degrees apart as shown. Bolt slots are 0.62-inches wide x 1.0 long. Overall width of flange is 5.0 inches (127 mm) and overall length is 7.5 inches (190.5 mm). Bolts should be located perpendicular to the sign face.



### Note

A customer-supplied template is recommended to hold the bolts in position while the concrete sets. See “Dimension Diagrams for Installation” on page 35 for additional base flange dimension details. Anchor bolts (customer-supplied) must be a minimum of 1.25 inches (31.75 mm) above the top surface of the concrete pad to attach the mounting bases. Hilti Quick Bolts (wedge-bolt) or Red Head Trubolt Wedge Anchors or, equivalent are recommended for installing the flanges after the concrete sets (customer-supplied). Check with the manufacturer for their recommendations as applied to your airport site.

Example Hilti Kwik Bolt 3 Standard Thread 304 Stainless Steel



### Note

With either anchoring system, the allowable load for any specific bolt length is dependent upon several factors; type of concrete, depth of embedded bolt, edge distance, anchor spacing, etc. Due to these factors, the airport engineer must select the appropriate bolt length. The bolt length is selected based on the local site conditions and the wind load force on the face of the sign. For additional information see the application drawing 117A0069 on the ADB SAFEGATE website Product Center at:

<http://www.adbsafegate.com>

**Figure 13: Two-hole (62A2142) and 4-hole (62A2146) Signs Couplings,**

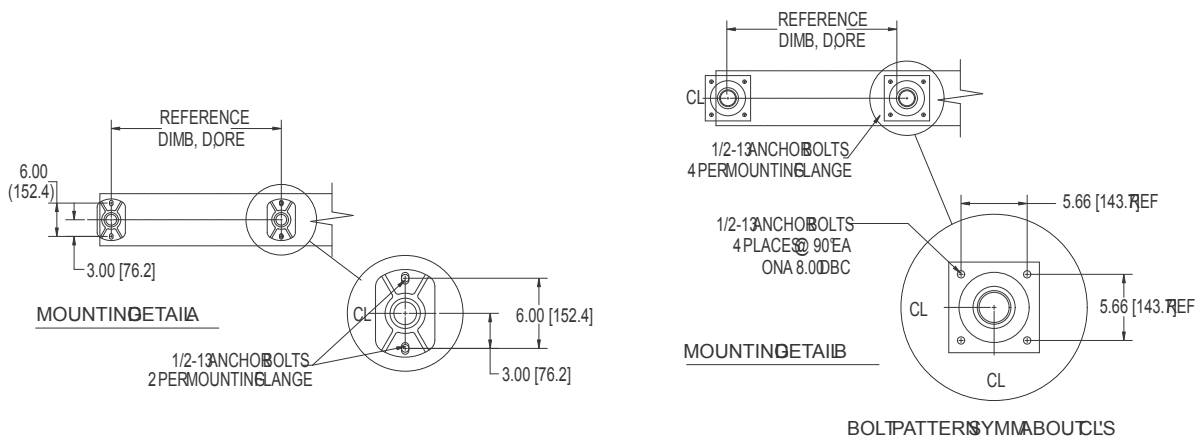

### 3.4.7 Sign Mounting



#### Note

Signs are fully assembled at the factory and are ready for installation with the exception of signs requiring a leg extension. Leg extensions are shipped with the sign and are easily added to raise the sign to the Canadian height requirement. Mounting flanges may be removed to lubricate the threads of the frangible coupling with anti-seize compound before installing the sign.

If the male L-823 connector is routed through a leg, slide the frangible coupling over the male connector and insert it into the female connector in the base plate, and then screw the frangible coupling into the base plate.

To mount the sign onto the concrete pad to ensure the assembly is flat, perform the following procedure:

1. When the sign is ready to be bolted to the concrete pad set the sign assembly on the concrete pad and position the sign over the anchor bolts. Hand-tighten the bolts or nuts to fasten the mounting flanges to the concrete pad.

2. **To ensure that the sign assembly is mounted flat on the concrete pad**, first loosen all three hex set screws found on each frangible coupling that are installed on the sign. See [Figure 14](#). Once all the hex screws are loosened each of the sign legs will float free inside the frangible coupling that is screwed into the mounting flange. Second, use a bubble, digital, or laser level to verify that the assembly is flat and level. Adjustments to make the assembly flat and level can be made by raising or lowering one end of the sign assembly to make the assembly flat and level.



### Note

Once the assembly is flat it may be necessary to block-up or hold the assembly in the flat position until all of the hex set screws can be re-tightened on each of the frangible couplings to secure the sign leg to the coupling. Once the sign is flat and level, finish tightening the mounting bolts to their correct torque value.

If the sign pad is tapered in the area where the mounting flanges are located, shims may need to be placed under the mounting flanges to ensure that the coupling frangibility characteristics are the same for each coupling. If in doubt, contact the ADB SAFEGATE Sales Department for further assistance.

**Figure 14: Sign Frangible Coupling**



### CAUTION

Sign frangible couplings are uniquely designed for use on the sign size stamped on the coupling and can only be used for that particular size sign. If couplings must be replaced, make sure the sign size on the couplings matches the size sign on which they are to be installed.

3. Connect an AWG 6 (16.0 mm<sup>2</sup>) (minimum) ground wire to the earth ground lug on the bottom of the sign. Refer to ["Wiring Diagrams"](#) for electrical connections on a series circuit installation.



### WARNING

Lock out power before making any electrical connections. Failure to observe this warning may result in personal injury, death, or equipment damage.

4. Install optional tether. Refer to *Optional Tethers* in this section.
5. Plug the cord set into the sign and the transformer.
6. Reinstall panels (if removed) and top lid (if removed).

## 3.5 Wiring

Refer to “[Wiring Diagrams](#)” for wiring diagrams.

When installing cable, follow the guidelines below.

- Operate the signs as a part of a series lighting system. The signs are connected into the series circuit by means of an isolation transformer, see “[Electrical Supply](#)”. If installation is to be independent of other lighting circuits, use current edition of ICAO Annex 14 or TP312 for additional guidance.

## 3.6 Series Wiring Isolation Transformers

The following section applies only to signs that require two isolation transformers and in some installations where it is desirable to replace one high-wattage isolation transformer with two lower-wattage isolation transformers.

For larger signs that require two isolation transformers for operation the two isolation transformers shall be wired in series to provide the total wattage required for operation. If unsure of the isolation transformer(s) required for the sign, refer to the Sign Load & Transformer Requirements section in this user manual.

When a high-wattage isolation transformer is required, it is permissible to use two lower-wattage isolation transformers instead. This can only be done if they are series-wired and provided the total wattage of the two isolation transformers equals the isolation transformer it is replacing. For example, you can replace the 500 W isolation transformer with series-wired 300 W and 200 W isolation transformers.



### Note

On occasion, the windings in the Isolation Transformers may be wired differently. The result will be that the output voltage on the secondary of the isolation transformer will be out of phase when the two transformers are in series. This condition will result in improper operation of the sign. This situation is resolved by replacing the field splice kit on one of the transformer's secondary and reversing the wires.

---

See [Table 7](#) for kits/parts required for series wiring isolation transformers. See [Figure 15](#) for series wiring isolation transformer installation.

**Table 7: Series Wiring Isolation Transformer Kits**

Item	Description	Part Number	Quantity
1	L-830 series wire kit	94A0173	1
2	Style 11 receptacle kit	70A0046	1
3	Jumper wire	89A0154	6 feet
4	Style 4 plug kit	70A0045	2



### Note

See above concerning phasing when transformers are in series.

---

Figure 15: Series Wiring Isolation Transformer Installation

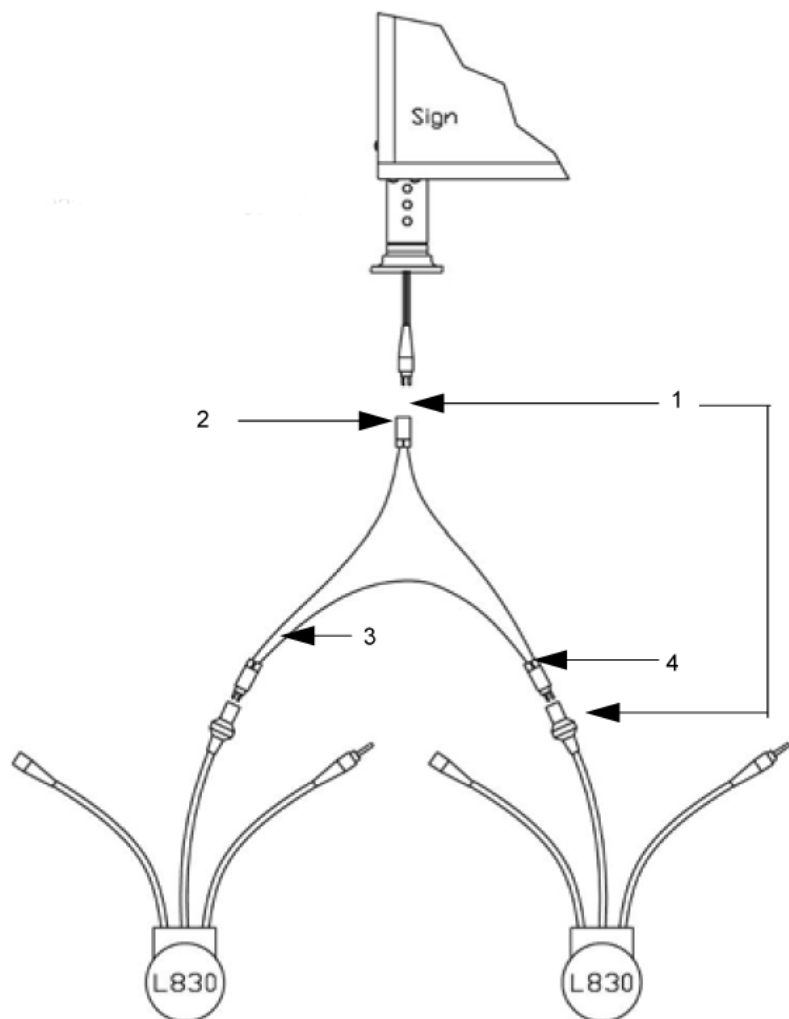

**Note**

Male cord-set supplied with the sign.

### 3.7 Earth Ground Lug



**WARNING**

- Signs must be properly grounded to true earth ground. Failure to observe this warning may result in personal injury, death, or equipment damage.

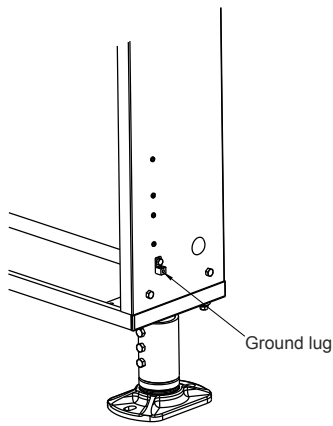

Connect a minimum 12 AWG ground wire to the earth ground lug located on the outside of the side panel on the power side of the sign.

If necessary, remove the ground lug from outside of the sign and re-attach it to the inside of the sign frame.

### 3.8 Tethers

Sign tether anchor hard points must be provided on one sign mounting leg above the frangible breaking point. Tether anchor hard points must be provided so that one end of the tether attaches to the sign structure, and the other end attaches below the frangible point of the coupling.

When installing a sign, attach the tether to either one of the leg mounting bolts or an independent bolt in the sign concrete mounting pad. See Figure.

FAA AC 150/5345-44 specifies there must be a minimum of one tether for single-module signs, and a minimum of two tethers for multiple-module signs with continuous frame. For multiple-module signs, one tether is attached to both ends of the sign.

Tethers are factory installed and attached to the bottom of the sign. The location and quantity of tethers is determined when the order is placed.

**Figure 16: Installing Tether**

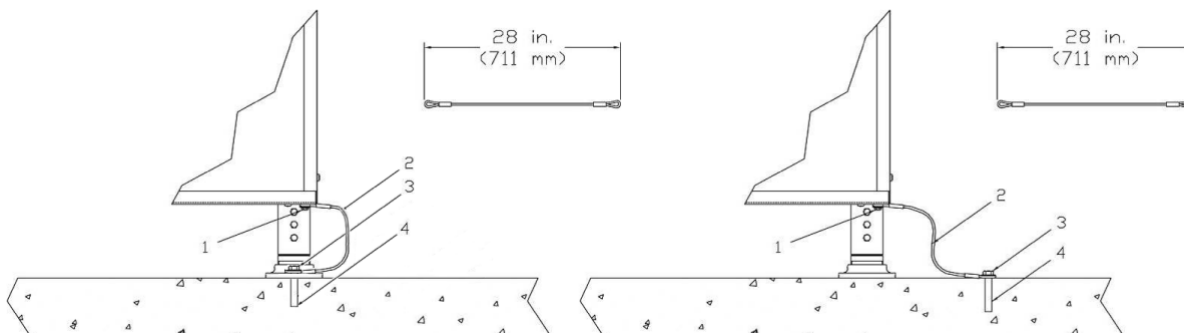

1. Sign frame anchor point, 5/16-18 x 3/4 in stainless-steel bolt.
2. Stainless-steel tether.
3. Tether attached to the anchor bolt
4. Anchor bolt

## 4.0 Maintenance and Repair



### WARNING

#### Injury or Equipment Damage

Read installation instructions in their entirety before starting maintenance.

- Read and carefully follow the instructions throughout this manual for performing specific tasks and working with specific equipment.
- Follow all applicable safety procedures required by your company, industry standards and government or other regulatory agencies.

This equipment may contain electrostatic sensitive devices.

- Protect PCBs from electrostatic discharge.
- Electronic modules and components should be touched only when this is unavoidable e.g. soldering, replacement.
- Before touching any component of the cabinet you should bring your body to the same potential as the cabinet by touching a conductive earthed part of the cabinet.
- Electronic modules or components must not be brought in contact with highly insulating materials such as plastic sheets or, synthetic fiber clothing. They must be laid down on conductive surfaces.
- The tip of the soldering iron must be grounded.
- Electronic modules and components must be stored and transported in conductive packing.
- Do not replace components with the power on.

**Failure to follow these warnings may result in serious injury or equipment damage.**

This section provides preventive maintenance for the ICAO/TP312 LED signs.

To keep the taxiway and runway signs operating efficiently, follow a preventive maintenance schedule. Refer to [Table 8](#).

**Table 8: Preventative Maintenance Schedule**

Interval	Maintenance Task	Action
Daily	Check for good sign illumination	Inspect, troubleshoot, and replace components as necessary
Monthly	Check for dirty panels	Clean with mild soap and water to remove any dirt, dust, or debris
	Check for vegetation covering the panel	Remove vegetation
6 months	Check for loose wire connections	Secure or repair wire connections
	Check for cracked or deteriorated wires	Repair or replace damaged wires
	Verify the sign is level	Adjust the sign legs as necessary
	Inspect and clean the interior of the sign	Clean with mild soap and water to remove any dirt, dust, or debris
	Inspect and clean the channel in the sign frame where the legend panel rests	Clean with mild soap and water to remove any dirt, dust, or debris
	Inspect LED bars for damage or failed LEDs	Troubleshoot and replace LED bars as necessary
Annually	Check the sign frame for scratches, corrosion, or paint flaking off	Remove corrosion and touch-up-paint as needed
	Check for discolored or faded panels	Clean or replace panels as needed
	Check for deteriorated gaskets	Replace damaged gaskets as needed



## Note

### TORQUE ALL:

5/16-18 bolts to  $115 \pm 10$  inch-pounds, ( $13 \pm 1$  N•m) (except: Torque top cover lid bolts)

Torque top cover 5/16-18 lid bolts to  $50 \pm 5$  lb/in ( $5.7 \pm 0.6$  N•m).

3/8-16 bolts to  $200 \pm 10$  inch-pounds ( $22.6 \pm 1$  N•m)

---

## 4.1 Replacing a LED Light Bar

---



## CAUTION

This equipment contains electrostatic sensitive devices.

- Protect the LED light bar kit from electrostatic discharge.
  - Failure to secure light bar may result in equipment damage.
- 

**Figure 17: Three Sizes of Light Bars**



1. De-energize and lock-out the airfield circuit before performing any sign maintenance.
2. Remove the top cover and legend panel.
3. Disconnect the damaged LED bar by separating the quick-slide terminals on both red and black wires on both ends of the LED bar.
4. Loosen but do not remove the small Phillips pan head screws securing the LED bar to the LED mounting bracket.
5. Remove the hex head screws securing the LED mounting bracket to the sign frame. Retain screws for re-assembly.
6. Note the orientation of the LED bar, remove the LED bar from the LED mounting brackets and replace the led bar.
7. Re-install the LED mounting brackets to the sign frame.
8. Center the LED bar within the module, tighten the Phillips pan head screws to secure the LED bar to the LED mounting bracket. Do not over-tighten the screws, this may damage the LED bar.
9. Re-connect the quick-slide terminals on both ends of the LED bar. Replace the panels, top cover and restore the power to the sign.
10. Check that all electrical connections are tight.
11. Restore power to the sign to confirm operation.
12. Re-install the front legend panel and top cover. Torque top cover bolts to  $50 \pm 5$  lb/in ( $5.7 \pm 0.6$  N•m).

## 4.2 Replacing the Single Power Supply



### DANGER

NEVER REPLACE A POWER SUPPLY WITH POWER APPLIED TO THE SIGN.

1. Disconnect the wires from the power supply.
2. Remove the old power supply by removing the four #8-32 screws with lock washers installed in the PEM nuts of the power supply. Retain for future use. See [Figure 18](#).
3. Apply thermal compound to the mating surface of the power supply to ensure good heat transfer to the frame.
4. Locate the four threaded PEM nuts installed in the mounting bracket of the Power Supply and align the PEM nuts with the mating holes in the end panel of the sign.
5. Insert the four #8-32 screws with lock washers through the holes in the end panel and screw them into the PEM nuts. When tightening the screws, make sure the Power Supply is seated flat against the side of the sign.



### CAUTION

Be careful that the screws do not bind as you are tightening. This may give the impression that the power supply is firmly mounted when it is not!

### 4.2.1 Wiring the Single Power Supply

See "[Wiring Diagrams](#)".

1. Locate the input power wires (from the isolation transformer secondary). Connect these wires to the Power Supply terminals labeled "AC INPUT". This is the isolated 6.6A input. Polarity does not matter. They must go through the cover.
2. Locate the wires that connected the DC Supply to the first LED light bar. Connect these wires to the Power Supply terminals labeled "OUTPUT". They must go through the cover.



### Note

This is a DC current source, and polarity does matter.

3. Check the position of the shunt on P1. See [Figure 18](#) below.



### Note

For signs shipped prior to March 2015 the PCB outputs either 520mA DC (single-side sign) or 770mA DC (double-sided sign) as set by shunt on P1 on the power supply.

For signs shipped after March 2015 the PCB outputs 770mA DC (single-sided and double-sided signs) as set by no shunts on P1 on the power supply.

- a. For ICAO/TP312 signs shipped prior to Mar 2015, signs operate at 520 mA. If field replacing the Power Supply, remove the shunt on P1 position 1 & 2. and connect to position 7 & 8. This will ensure that the brightness of the sign will not change.
  - b. For ICAO/TP312 signs shipped after Mar 2015, signs operate at 770 mA. If field replacing the Power Supply, ensure no shunt on P1 is connected at positions 1 & 2, or 7 & 8. This will ensure that the brightness of the sign will not change.
4. Verify that the sign wiring matches the "[Wiring Diagrams](#)".

5. You are now ready to apply power to the sign.

**Figure 18: Single Power Supply Shunt Position**

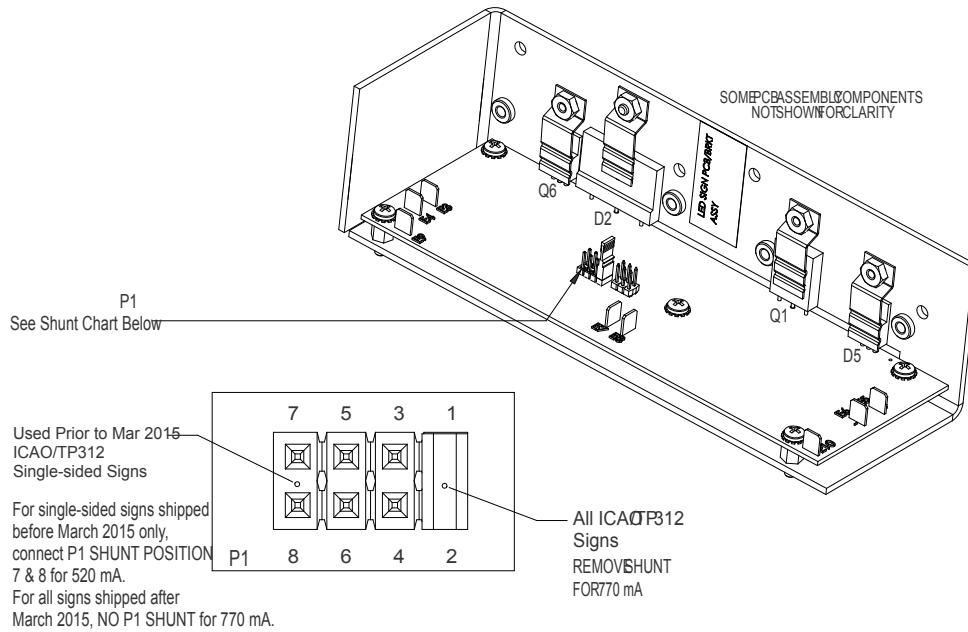

(see wiring diagram 43A4143 [Figure 21](#))



### Note

For the Dual-Power Supply (see [“Replacing the Dual Power Supply”](#)).

## 4.2.2 Checking the Power Supply

When power is applied...

- All of the LED light bars should illuminate and the on board LED (D4) will stay off if all components are wired and functioning correctly.
- If the LED light bars do not illuminate and the on board LED (D4) comes on, there is an open in the output current loop to the LED light bars. Remove the input power and check the output wiring for correct polarity and opens or shorts referring to [“Wiring Diagrams”](#).
- If the LED light bars do not illuminate and the on board LED (D4) does not illuminate, then there is a fault on the power supply board or incoming power. Remove the input power and check the input wiring for opens or shorts.
- Verify the P1 shunt is configured properly. See [Figure 18](#).

## 4.3 Replacing the Dual Power Supply



### DANGER

ELECTRIC SHOCK

NEVER REPLACE A POWER SUPPLY WITH POWER APPLIED TO THE SIGN.

1. Remove the four #8-32 screws with lock washers installed in the PEM nuts of the power supply. Retain for future use. See [Figure 19](#).
2. Apply thermal compound to the mating surface of the power supply to ensure good heat transfer to the frame.
3. Locate the four threaded PEM nuts installed in the mounting bracket of the Power Supply and align the PEM nuts with the mating holes in the end panel of the sign.

4. Insert the four #8-32 screws with lock washers through the holes in the end panel and screw them into the PEM nuts. When tightening the screws, make sure the Power Supply is seated flat against the side of the sign.



### CAUTION

Equipment Damage

Be careful that the screws do not bind as you are tightening. This may give the impression that the power supply is firmly mounted when it is not!

## 4.3.1 Wiring the Dual-Power Supply

See “Wiring Diagrams”.

1. Locate the input power wires (from the isolation transformer secondary). Connect these wires to the Power Supply terminals labeled “AC INPUT”. This is the isolated 6.6A input. Polarity does not matter.
2. Locate the wires that connected the DC Supply to the first LED light bar. Connect these wires to the Power Supply terminals labeled “OUTPUT”.



### CAUTION

This is a DC current source, and polarity does matter.

3. Check the position of the shunt on P1. See [Figure 19](#).



### Note

For signs shipped prior to March 2015 the PCB outputs either 520mA DC (single-side sign) or 770mA DC (double-sided sign) as set by shunt on P1 on the power supply.

For signs shipped after March 2015 the PCB outputs 770mA DC (single-sided and double-sided signs) as set by no shunts on P1 on the power supply.

- a. For ICAO/TP312 signs shipped prior to Mar 2015, signs operate at 520 mA. If field replacing the Power Supply, remove the shunt on P1 position 1 & 2. and connect to position 7 & 8. This will ensure that the brightness of the sign will not change.
  - b. For ICAO/TP312 signs shipped after Mar 2015, signs operate at 770 mA. If field replacing the Power Supply, ensure no shunt on P1 is connected at positions 1 & 2, or 7 & 8. This will ensure that the brightness of the sign will not change.
4. Verify that the sign wiring matches [Figure 23](#).

5. You are now ready to apply power to the sign.

**Figure 19: Sign Dual Power Supply Shunt Position**

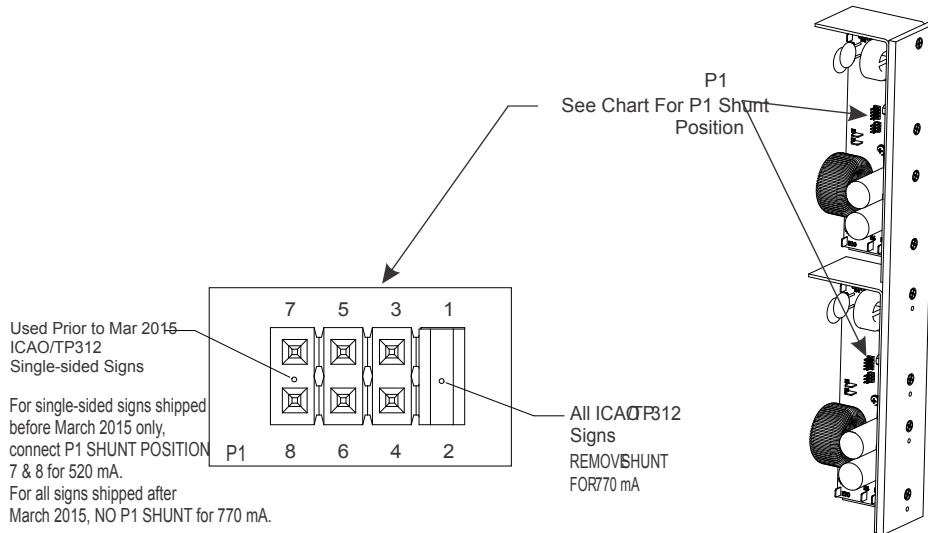

### 4.3.2 Checking the Dual Power Supply

When power is applied...

- All of the LED light bars should illuminate and the on board LED (D4) will stay off if all components are wired and functioning correctly.
- If the LED light bars do not illuminate and the on board LED (D4) comes on, there is an open in the output current loop to the LED light bars. Remove the input power and check the output wiring for correct polarity and opens or shorts referring to [Figure 23](#).
- If the LED light bars do not illuminate and the on board LED (D4) does not illuminate, then there is a fault on the power supply board or incoming power. Remove the input power and check the input wiring for opens or shorts.
- Verify the P1 jumper on the power supply is configured properly. See [Figure 19](#).

## 4.4 Sign Bolt Torque Diagram

The sign assembly bolt torque value are depicted in the following diagram.

Figure 20: Bolt Torque Diagram

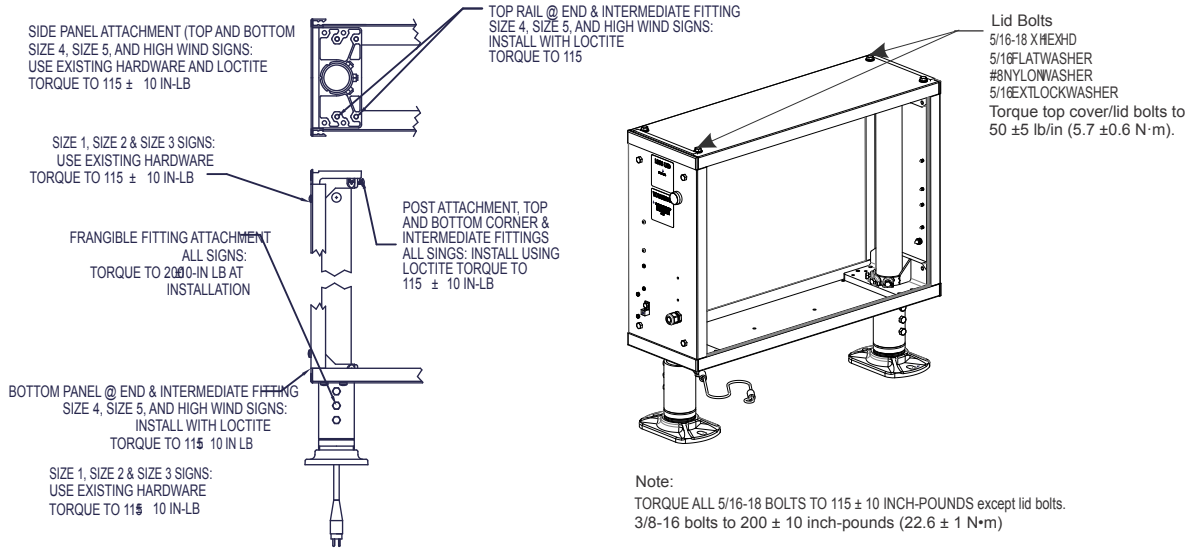

### Note

TORQUE ALL:

5/16-18 bolts to 115 ± 10 inch-pounds, (13 ± 1 N·m) (except: Torque top cover lid bolts)

Torque top cover 5/16-18 lid bolts to 50 ± 5 lb/in (5.7 ± 0.6 N·m).

3/8-16 bolts to 200 ± 10 inch-pounds (22.6 ± 1 N·m)



## 5.0 Troubleshooting



### WARNING

#### Electrical Shock

Read installation instructions in their entirety before starting maintenance or repairs.

- Read and carefully follow the instructions throughout this manual for performing specific tasks and working with specific equipment.
- Follow all applicable safety procedures required by your company, industry standards and government or other regulatory agencies.

This equipment may contain electrostatic sensitive devices.

- Protect PCBs from electrostatic discharge.
- Electronic modules and components should be touched only when this is unavoidable e.g. soldering, replacement.
- Before touching any component of the cabinet you should bring your body to the same potential as the cabinet by touching a conductive earthed part of the cabinet.
- Electronic modules or components must not be brought in contact with highly insulating materials such as plastic sheets or, synthetic fiber clothing. They must be laid down on conductive surfaces.
- The tip of the soldering iron must be grounded.
- Electronic modules and components must be stored and transported in conductive packing.
- Do not replace components with the power on.

**Failure to follow these warnings may result in serious injury or equipment damage.**

This section provides troubleshooting information for the taxiway and runway signs. The information covers only the most common problems. If you cannot solve the problem with the information given here, contact your local ADB Safegate representative for help.

## 5.1 Theory of Operation

See [Figure 15](#) and the schematics shown in [Figure 21](#) and [Figure 23](#). A current of 2.8 to 6.6 A is the input into the power supply PCB.



### Note

For signs shipped prior to March 2015 the PCB outputs either 520mA DC (single-side sign) or 770mA DC (double-sided sign) as set by shunt on P1 on the power supply.

For signs shipped after March 2015 the PCB outputs 770mA DC (single-sided and double-sided signs) as set by no shunts on P1 on the power supply.

All LED light bars are connected in series. Each light bar has a number of internally connected white LEDs connected in series. The positive (+) output of the DC power connects to the anode of all the LED light bars in series.

**Table 9: Standard LED Signs**

Problem	Possible Cause	Corrective Action
All LEDs are <b>OFF</b>	Sign ON/OFF Switch is in the Closed/Shorted Position	<p>Not all signs are equipped with a switch.</p> <p>With field current ON, ensure the switch is in the open position for current to pass through to the power supply. The Push-Button switch position (Out = Open for the sign to be ON). For the sign to be OFF, the Push-Button switch position is (IN = Closed/Shorted for the sign to be OFF).</p>
	No Current or Incorrect Input Current	<p>With field current ON, verify correct current is coming into the sign. Using a true RMS ammeter clamp, measure the current on the secondary and ensure proper current at all steps:</p> <ul style="list-style-type: none"> <li>▪ 5-Step (2.8-6.6 A)</li> <li>▪ 3-Step (4.8-6.6 A)</li> <li>▪ 1-step (5.5 A)</li> </ul> <p>Check the L-830 transformer wattage rating: if it is too small, a higher wattage transformer is needed.</p>
	Loose Wires or Connections	<p>Check for loose wires and tighten or replace wires as necessary. All LED are connected in series to a power supply. If there are any loose or open connections, all the LED bars will be OFF.</p>
	Faulty ON/OFF Switch	<p>Not all signs are equipped with a switch.</p> <p>With field current ON, verify the Push-Button switch position (Out = Open for the sign to be ON). Using a true RMS ammeter clamp, verify expected series circuit current exists in the AC POWER input wires connected to E3 and E4 on the power supply, see Figure 11 LED Power Supply. If current does not exist, the switch is faulty, replace the switch.</p>
	Faulty power supply	<p>For a normal operating sign and power supply, when power is first applied, the green LED D4 "heartbeat LED" on the power supply PCB will begin flashing and stabilize at a rate of 2 flashes per second. If the power supply senses an open circuit, the green LED D4 will turn OFF.</p> <p>With field current on, measure the DC voltage at E7 to E8, see Figure 11. The voltage should be 10-13 VDC on a properly operating power supply. The voltage should be 10-13 VDC on a properly operating power supply. If the proper voltage does not exist, replace the power supply.</p> <p>Remove input power, disconnect the DC OUTPUT connections at E5 and E8. Using a multi-meter connect probes at E5 to E8. Restore power and look for a rising voltage up to approximately 190 VDC within the first few seconds of powering on the sign. The voltage will then drop to approximately 50 VDC and then cycle between approximately 190 VDC to 50 VDC before stabilizing at approximately 190 VDC. If this behavior does not exist, replace the power supply.</p> <p>If the voltage is between 50-190 VDC during the first few seconds of applying power, the power supply is likely good. To reset the power supply and initiate a new startup procedure, the input power to the power supply must be disconnected for about 1 minute to fully drain any stored power. Remove input power and reconnect the connections at E5, E7, and E8.</p>
	Faulty Resistor	<p>Not all signs are equipped with a resistor, see Figure 14 to determine if your sign should be equipped with a resistor.</p> <p>Disconnect the resistor and using a multimeter, measure the resistance of the 100 Ohm resistor located along the top rail of the sign. The resistance should be approximately 100 Ohms. If the resistor is faulty, replace the resistor.</p> <p>Ensure the resistor is securely fastened to the top rail of the sign frame without any gaps between the mating surfaces. If replacing the resistor, ensure an adequate amount of heat conductive thermo-joint compound is applied to the mating surface to properly dissipate heat.</p>

Problem	Possible Cause	Corrective Action
All LEDs are <b>OFF</b>	Faulty LED Bar	<p>Disconnect the LED bars and using the LED tester 44A7264/1, test each LED bar. If the LED bar does not illuminate, replace the LED bar. If the LED bar illuminates, carefully observe each of the LEDs within the LED bar to ensure all LEDs are operating properly.</p> <p>Size 1 and 4 signs have 16" LED bars, each have 6 LEDs. Size 2 signs have 24" LED bars, each have 9 LEDs. Size 3 and 5 signs have 32" LED bars, each have 12 LEDs.</p> <p>If any LEDs within the LED bar are not illuminated or appear dim, replace the LED bar.</p> <hr/> <div style="display: flex; align-items: center;">  <div> <p><b>CAUTION</b></p> <p>Never connect a single LED light bar directly to the power supply. The power supply is designed to have a minimum load connected to it. Connecting only one LED light bar to a power supply will result in LED current being too high and damage the LED bar.</p> </div> </div> <hr/>
LEDs are Dim	<p>No Current or Incorrect Input Current</p> <hr/> <p>Faulty LED Bar</p>	<p>Verify correct current is coming into the sign using a true RMS ammeter. Ensure proper current at all steps:</p> <ul style="list-style-type: none"> <li>▪ 5-Step (2.8-6.6 A)</li> <li>▪ 3-Step (4.8-6.6 A)</li> <li>▪ 1-step (5.5 A)</li> </ul> <p>Check the L-830 transformer wattage rating, if it is too small, a higher wattage transformer is needed.</p> <hr/> <p>While the sign is illuminated, observe each of the LEDs within the LED bars to ensure all LEDs are operating properly. If any LEDs inside the LED bar are not illuminated or appear dim, replace the LED bar.</p> <p>Size 1 and 4 signs have 16" LED bars, each have 6 LEDs. Size 2 signs have 24" LED bars, each have 9 LEDs. Size 3 and 5 signs have 32" LED bars, each have 12 LEDs.</p>



## 6.0 Wiring Diagrams

Figure 21: LED ICAO Sign, Single Power Supply and Light Engine Diagram

NOTES:

- 1) THE L823 CONNECTION TO THE PCB DOES NOT REQUIRE POLARIZATION.
- 2) THE LAST LIGHT BAR OF THE "CHAIN" ENDS WITH A "RESISTOR ASSY" OR THE LEADS ARE CONNECTED TOGETHER.
- 3) CHECK LIGHT BAR LEAD CONNECTIONS (WIRE TO TERMINAL, AND TERMINAL TO TAB) TO THE PWR SUPPLY FOR TIGHTNESS. CRIMP/SQUEEZE THE TERMINAL CONNECTION WITH PLIERS TO TIGHTEN TO TAB; REPLACE TERMINAL IF WIRE IS REMOVED.
- 4) REMOVE P1 SHUNT FOR "ICAO".

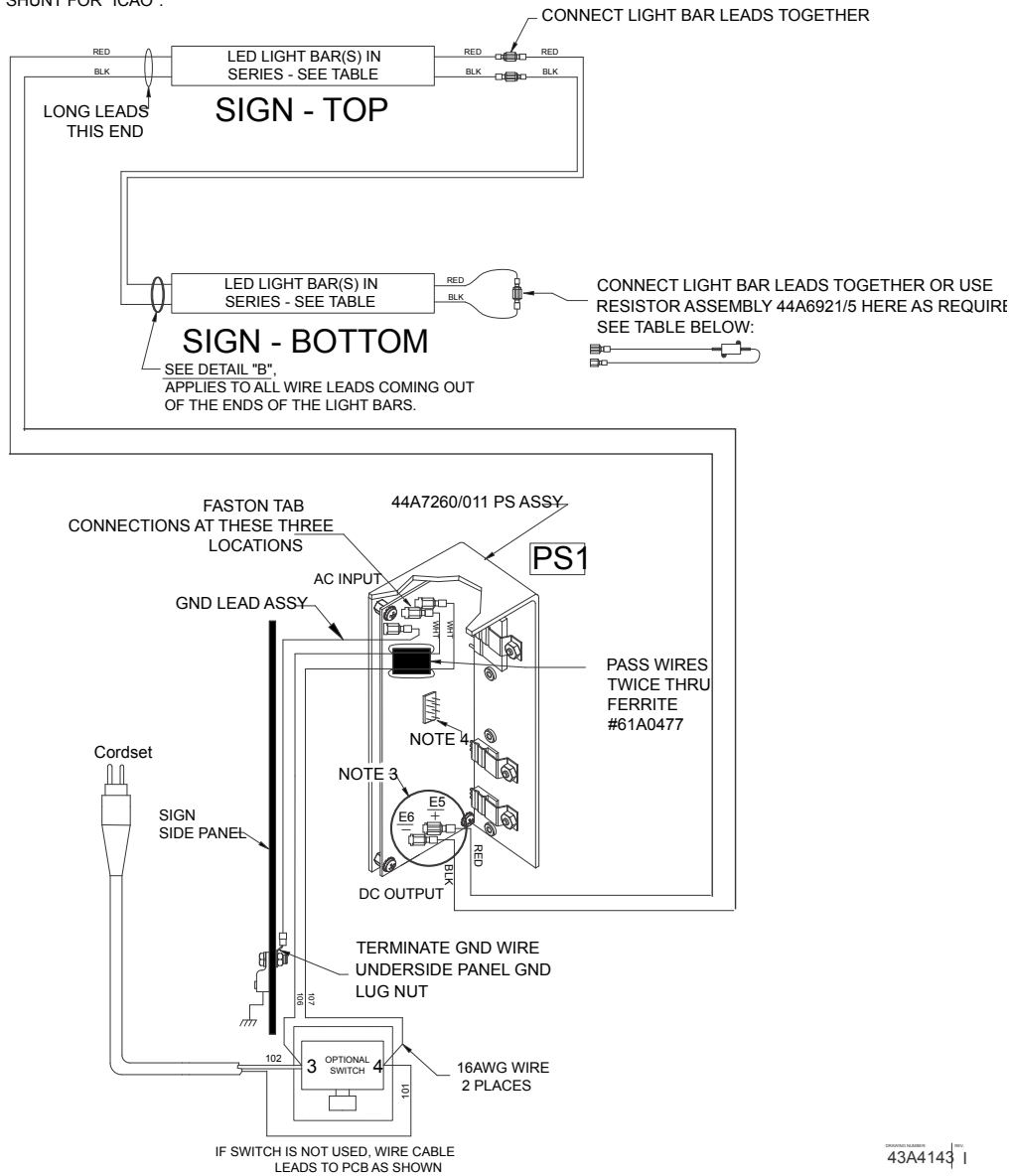
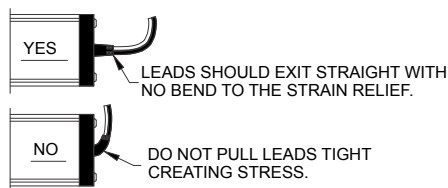

Figure 22: Detail B



**Table 10: Power Supply: LED Light Bar and Termination Chart**

Sign Length	Light Bars			Sections	Light Bars Top	per Section Bottom	Termination
	48A0442/16	48A0442/24	48A0442/32				
700	2	-	-	1	(16)	(16)	Terminating Resistor
900	-	2	-	1	(24)	(24)	Terminating Resistor
1100	-	-	2	1	(32)	(32)	Connect Leads
1300	2	2	-	1	(16) + (24)	(16) + (24)	Connect Leads
1500	-	4	-	1	(24) + (24)	(24) + (24)	Connect Leads
1700	-	4	-	2	(24)	(24)	Connect Leads
1900	-	4	-	2	(24)	(24)	Connect Leads
2100	-	-	4	2	(32)	(32)	Connect Leads
2300	-	-	4	2	(32)	(32)	Connect Leads
1200	4	-	2	2	(16)	(16)	Connect Leads



**Note**

1200 mm length distance remaining signs include additional side mounted 32" Light Bars.

Figure 23: LED ICAO Sign, Dual-Power Supply Diagram

NOTES:

- 1) THE L823 CONNECTION TO THE PCB DOES NOT REQUIRE POLARIZATION.
- 2) THE LAST LIGHT BAR OF THE "CHAIN" ENDS WITH A "RESISTOR ASSY" OR THE LEADS ARE CONNECTED TOGETHER.
- 3) CHECK LIGHT BAR LEAD CONNECTIONS (WIRE TO TERMINAL, AND TERMINAL TO TAB) TO THE PWR SUPPLY FOR TIGHTNESS. CRIMP/SQUEEZE THE TERMINAL CONNECTION WITH PLIERS TO TIGHTEN TO TAB; REPLACE TERMINAL IF WIRE IS REMOVED.
- 4) REMOVE P1 SHUNT FOR "ICAO".

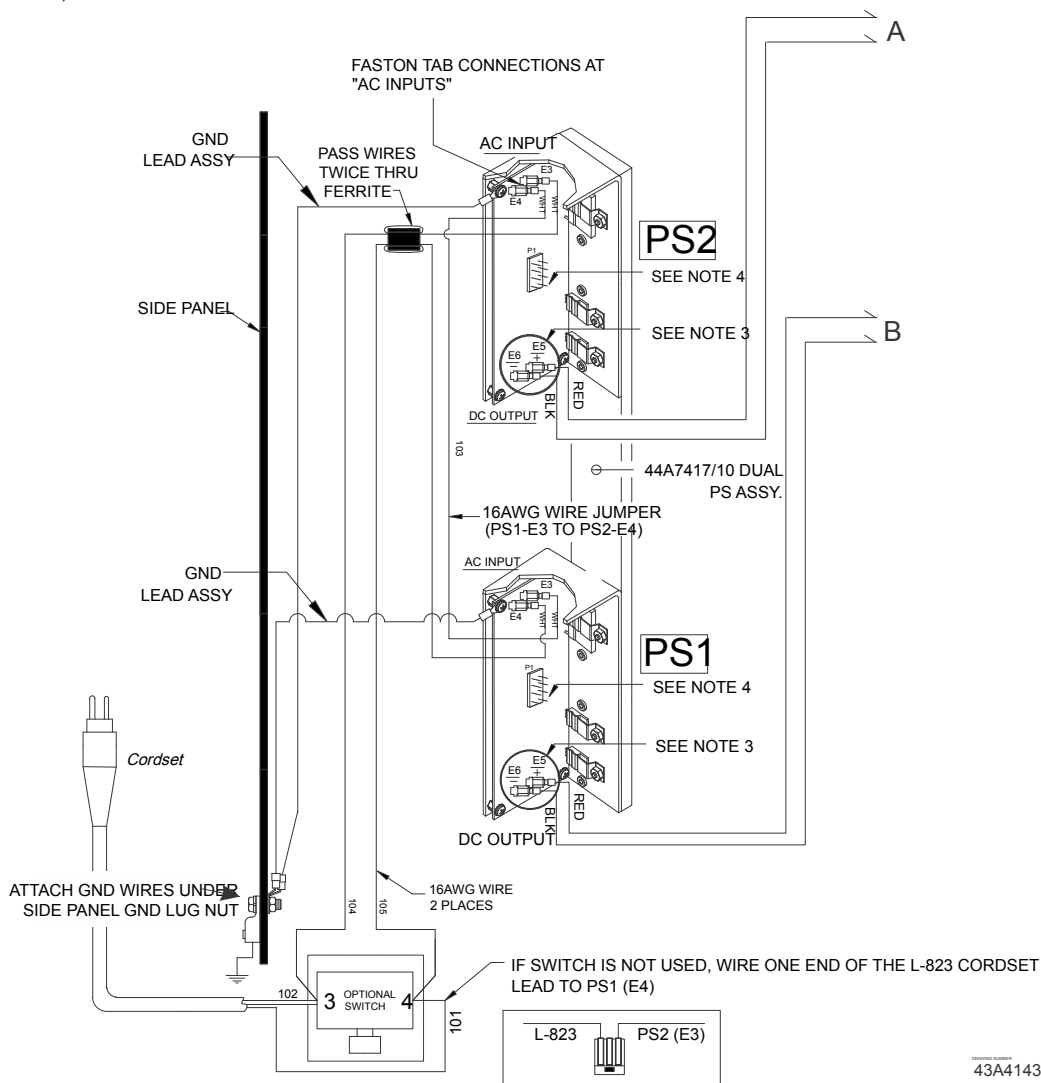

**Figure 24: LED ICAO Sign, Dual Power Supply Light Engine Diagram**

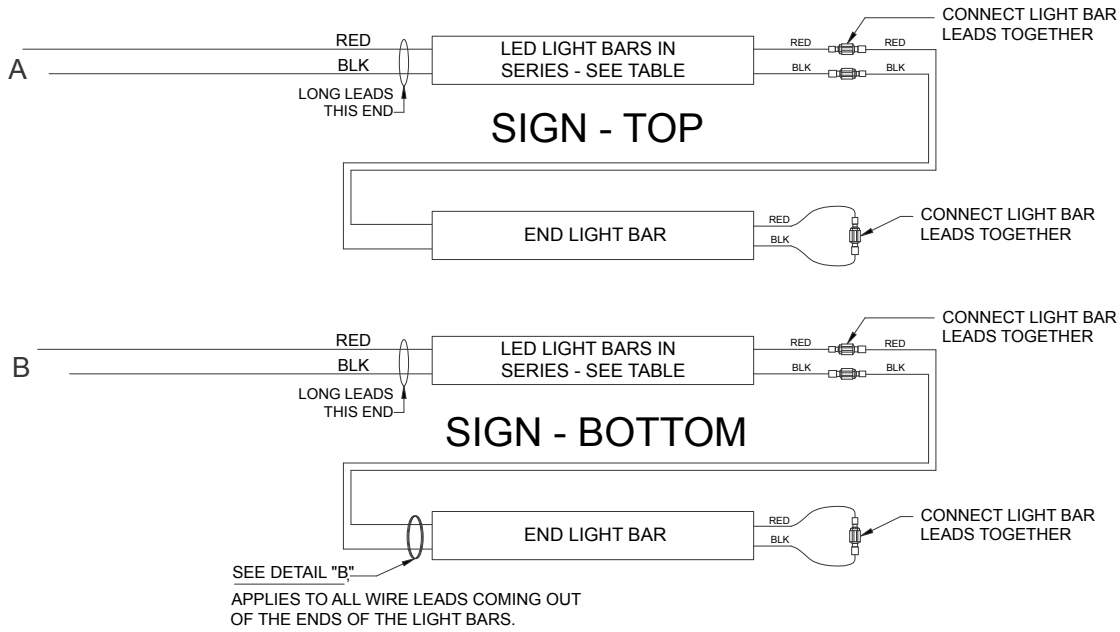

**Table 11: Dual Power Supply: LED Light Bar and Termination Chart**

Sign Length	48A0442/16	Light Bars 48A0442/24	48A0442/32	Sections	Light Bars Top	per Section Bottom	Termination
2500	4	4	-	2	(16) + (24)	(16) + (24)	Connect Leads
2700	4	4	-	2	(16) + (24)	(16) + (24)	Connect Leads
2900	4	-	4	2	(32) + (16)	(32) + (16)	Connect Leads
3300	-	-	6	3	(32)	(32)	Connect Leads
3700	4	4	2	3	See <a href="#">Figure 25</a>	See <a href="#">Figure 25</a>	Connect Leads

**Figure 25: Detail A**

16	24	32	16	24
16	24	32	16	24





## Note

Left/right designation determined when viewing secondary side of the sign. Customer to provide legend information and power connection side. Match power cord exit location with legend side. All signs are provided with an internal inspection window at the end of the sign.

## 7.2 Legend Panel Replacement Ordering Code

### Legend Panel Replacement

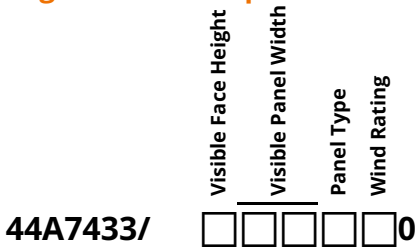

#### Panel Type

- 1 = With legend
- 2 = Black (blank)

#### Wind Rating

- 0 = Standard (322 km/h, 200 mph)

#### Visible Face Height

- 6 = 600 mm
- 8 = 800 mm

#### Visible Panel Width

- 07 = 700 mm
- 09 = 900 mm
- 11 = 1100 mm
- 13 = 1300 mm
- 15 = 1500 mm
- 17 = 1700 mm
- 19 = 1900 mm
- 21 = 2100 mm
- 23 = 2300 mm
- 25 = 2500 mm
- 27 = 2700 mm
- 29 = 2900 mm
- 33 = 3300 mm
- 37 = 3700 mm



## Note

Customer to specify character height and legend information.

### LED Light Engine Tester (Ordering Code: 44A76264/1)

Battery-powered tester is used during maintenance activities to separately test a single LED light bar. Uses four size D batteries and outputs 350 mA. Output is activated using a momentary switch.

## 7.3 Parts Diagrams

Figure 26: TP312/ICAO LED Sign Assembly Parts

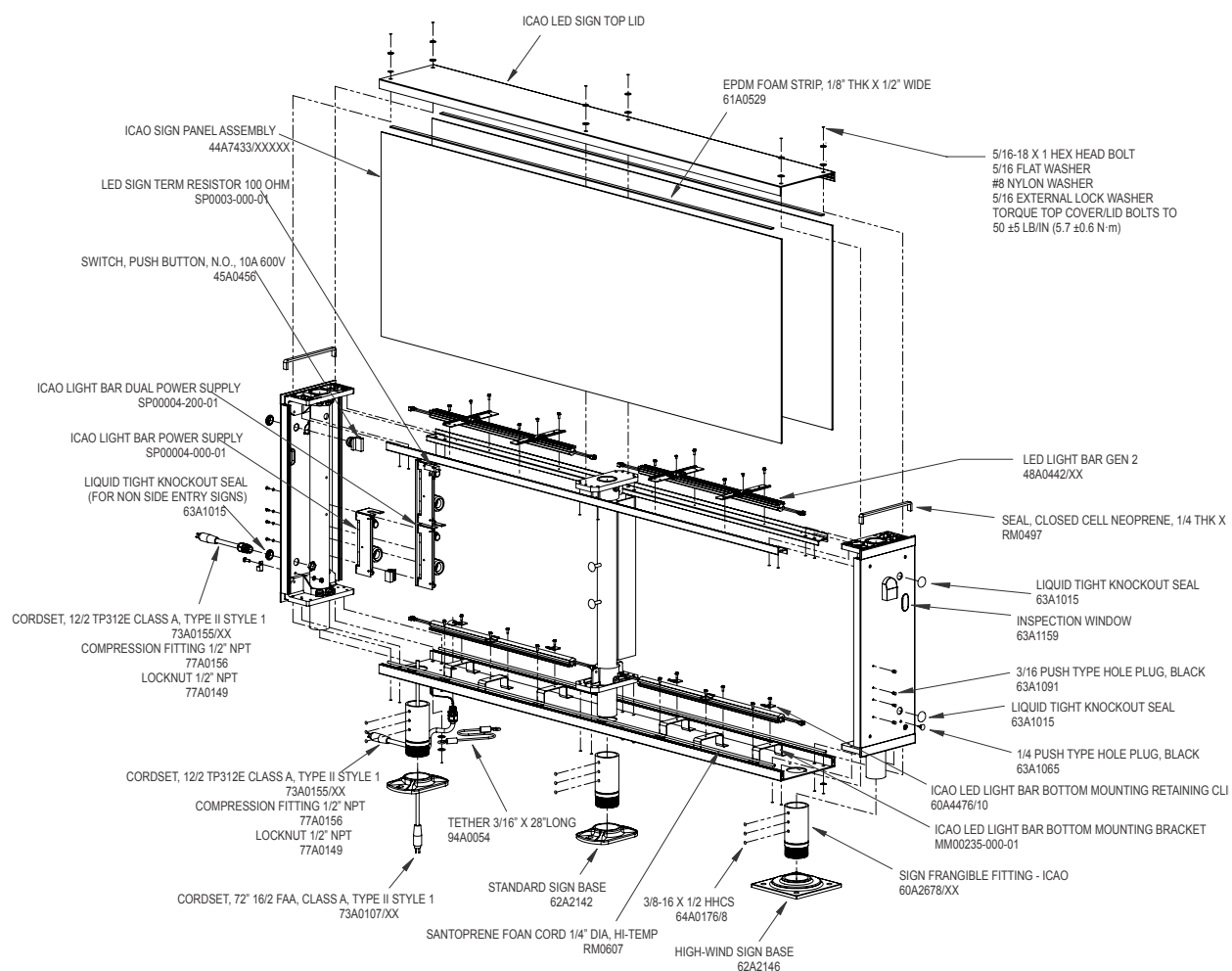

### Note

TORQUE ALL:

5/16-18 bolts to 115 ± 10 inch-pounds, (13 ± 1 N·m) (except: top cover lid bolts)

Torque 5/16-18 top cover lid bolts to 50 ±5 lb/in (5.7 ±0.6 N·m).

3/8-16 bolts to 200 ± 10 inch-pounds (22.6 ± 1 N·m)

Order kit 94A0649/ICAONB for a factory installed cover for the ON/OFF switch. The cover protects from inadvertent operation of the button associated with heavy snow being piled or blown against the sign.

**Figure 27: ON/OFF Switch Protective Cover**

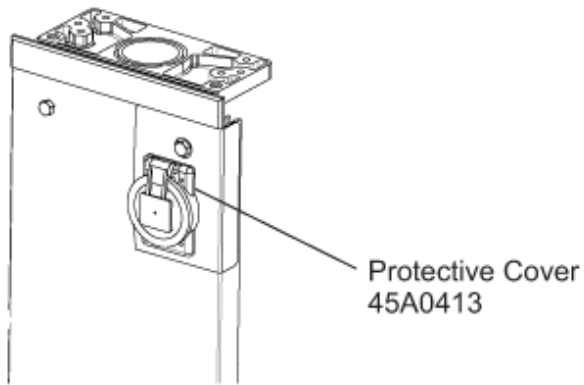

## 7.4 Spare Parts

Create a sufficiently large stock of spare parts to maintain the ICAO/TP312 LED Signs in the field. Consider acquiring approximately 10% of critical spare final assemblies (with a minimum quantity of one) for the total amount of equipment in the field. This allows for repairs to be made in the shop.

For the ICAO/TP312 LED Sign, see the tables below for spares.

- Consider acquiring 10% spares for critical components noted as (A) in the table below.  
If only a small number of LED SIGN units are installed, consider acquiring at least one of each of the components noted as (A) below.
- For large installations also consider acquiring 1% spares for parts noted as (B) in the table below. If it is important to have a robust level of spare parts on-hand, and only a small number of LED Signs are installed, consider acquiring one of each of the components noted as (B) below.

**Table 12: ICAO/TP312 LED Sign Spare Parts**

Part Number	Description	Figure	Notes	Spares
73A0107/XX	Cord set, L-823 (power through leg)	Figure 26	If Used	B
73A0155/X.X	Cord set, TP 312E, 12/2 SO cord, 2.5 m (other sign exit locations)	Figure 26	If Used	B
62A2142	Floor flange (2-bolt) <sup>1</sup>	Figure 26		B
62A2146	Floor flange (4-bolt) <sup>1</sup>	Figure 26		B
48A0442/16	LED Light Bar, 16"	Figure 26		A
48A0442/24	LED Light Bar, 24"	Figure 26		A
48A0442/32	LED Light Bar, 32"	Figure 26		A
94A0054	Tether	Figure 26		B
60A2678/XX	Sign Frangible Coupling - ICAO 600 mm Sign, Standard <sup>123</sup>	Figure 13 and Figure 26	see Table 13 and Table 14	B
60AXXX/XX	Sign Frangible Coupling - ICAO 800 mm Sign, Standard <sup>123</sup>	Figure 13	see Table 15 and Table 16	B
SP00004-200-01	Dual Power Supply Assembly <sup>45</sup>	Figure 26		A
SP00004-000-01	Single Power Supply Assembly <sup>65</sup>	Figure 26		A
SP00003-000-01	LED Sign Terminal Assembly Resistor 100 Ohm			B
45A0456	Switch Push Button, NO, 10 A, 600 VAC		If Used	B
RM0607	Foam Cord 1/4" Dia HI-Temp <sup>7</sup>	Figure 26	Used in bottom sign panel channel; ordered by foot	B
61A0529	EPDM Foam Strip, 1/8 in Thick x 1/2 in Wide (top faces above sign panel) <sup>8</sup>	Figure 26	ordered by foot	B
60A4323/XXX	Leg Extension	Figure 28		B
44A7264/1	Light Bar Tester			B
MM00235-000-01	Bottom LED Standoff Mounting Bracket		1200x1200 mm RDRS sign only	B
MM00099-000-01	Side LED Mounting U-Bolt		1200x1200 mm RDRS sign only	B
MM00255-000-01	Side LED Mounting Plate		1200x1200 mm RDRS sign only	B

<sup>1</sup> Refer to Tables 13 through 16 for the right floor flange.

<sup>2</sup> Refer to drawing 117A0069, ICAO & TP312 installation detail, for frangible coupling and foot option specification.

<sup>3</sup> Apply 67A0105 LOCTITE anti-seize to all frangible coupling threads.

<sup>4</sup> SP00004-200-01 dual power supply assembly used on illuminated face length options "L" through "P".

<sup>5</sup> See Figures 18 and 19 for configuration instruction.

<sup>6</sup> SP00004-000-01 single power supply used on illuminated face length options "A" through "K".

<sup>7</sup> RM0607 gaskets are cut to length and placed inside the channels along each side of the bottom panels.

<sup>8</sup> 61A0529 gaskets are cut to length and affixed with the adhesive side along both inside corners of the sign top lid.



**Note**

Installation drawing 117A0069 is available on the ADB SAFEGATE's website or you can request a copy from your sales representative

**Table 13: 600 mm Face - Standard Height Sign Coupling**

Size Modules	Illuminated Face Length	Frangible Coupling	Mounting Flange
SBXA/, SIXA/	700 mm	60A2678/10	62A2142
SBXB/, SIXB/	900 mm	60A2678/10	62A2142
SBXC/, SIXC/	1100 mm	60A2678/60	62A2142
SBXD/, SIXD/	1300 mm	60A2678/60	62A2142
SBXE/, SIXE/	1500 mm	60A2678/20	62A2142
SBXF/, SIXF/	1700 mm	60A2678/60	62A2142
SBXG/, SIXG/	1900 mm	60A2678/20	62A2142
SBXH/, SIXH/	2100 mm	60A2678/20	62A2142
SBXJ/, SIXJ/	2300 mm	60A2678/30	62A2142
SBXK/, SIXK/	2500 mm	60A2678/30	62A2142
SBXL/, SIXL/	2700 mm	60A2678/30	62A2142
SBXM/, SIXM/	2900 mm	60A2678/30	62A2142
SBXN/, SIXN/	3300 mm	60A2678/30	62A2142
SBXP/, SIXP/	3700 mm	60A2678/40	62A2142

**Table 14: 600 mm FACE - 48"; 60"; 72" HEIGHT SIGN Coupling**

Size Modules	Illuminated Face Length	Frangible Coupling	Mounting Flange
SBXA/, SIXA/	700 mm	60A2678/60	62A2142
SBXB/, SIXB/	900 mm	60A2678/20	62A2142
SBXC/, SIXC/	1100 mm	60A2678/30	62A2142
SBXD/, SIXD/	1300 mm	60A2678/40	62A2142
SBXE/, SIXE/	1500 mm	60A2678/40	62A2142
SBXF/, SIXF/	1700 mm	60A2678/40	62A2142
SBXG/, SIXG/	1900 mm	60A2678/21	62A2146
SBXH/, SIXH/	2100 mm	60A2678/21	62A2146
SBXJ/, SIXJ/	2300 mm	60A2678/50	62A2146
SBXK/, SIXK/	2500 mm	60A2678/50	62A2146
SBXL/, SIXL/	2700 mm	60A2678/41	62A2146
SBXM/, SIXM/	2900 mm	60A2678/41	62A2146
SBXN/, SIXN/	3300 mm	60A2678/41	62A2146
SBXP/, SIXP/	3700 mm	60A2678/41	62A2146

**Table 15: 800 mm Face - Standard Height Sign Couplings**

Size Modules	Illuminated Face Length	Frangible Coupling	Mounting Flange
SBXA/, SIXA/	700 mm	60A2678/60	62A2142
SBXB/, SIXB/	900 mm	60A2678/20	62A2142
SBXC/, SIXC/	1100 mm	60A2678/20	62A2142
SBXD/, SIXD/	1300 mm	60A2678/30	62A2142
SBXE/, SIXE/	1500 mm	60A2678/40	62A2142
SBXF/, SIXF/	1700 mm	60A2678/30	62A2142
SBXG/, SIXG/	1900 mm	60A2678/40	62A2142
SBXH/, SIXH/	2100 mm	60A2678/21	62A2146
SBXJ/, SIXJ/	2300 mm	60A2678/21	62A2146
SBXK/, SIXK/	2500 mm	60A2678/50	62A2146
SBXL/, SIXL/	2700 mm	60A2678/50	62A2146
SBXM/, SIXM/	2900 mm	60A2678/50	62A2146
SBXN/, SIXN/	3300 mm	60A2678/50	62A2146
SBXP/, SIXP/	3700 mm	60A2678/50	62A2146

**Table 16: 800 mm Face - 48"; 60"; 72" Height Sign Couplings**

Size Modules	Illuminated Face Length	Frangible Coupling	Mounting Flange
SBXA/, SIXA/	700 mm	60A2678/20	62A2142
SBXB/, SIXB/	900 mm	60A2678/30	62A2142
SBXC/, SIXC/	1100 mm	60A2678/30	62A2142
SBXD/, SIXD/	1300 mm	60A2678/40	62A2142
SBXE/, SIXE/	1500 mm	60A2678/21	62A2146
SBXF/, SIXF/	1700 mm	60A2678/21	62A2146
SBXG/, SIXG/	1900 mm	60A2678/50	62A2146
SBXH/, SIXH/	2100 mm	60A2678/50	62A2146
SBXJ/, SIXJ/	2300 mm	60A2678/41	62A2146
SBXK/, SIXK/	2500 mm	60A2678/41	62A2146
SBXL/, SIXL/	2700 mm	60A2678/41	62A2146
SBXM/, SIXM/	2900 mm	60A2678/41	62A2146
SBXN/, SIXN/	3300 mm	60A2678/41	62A2146
SBXP/, SIXP/	3700 mm	60A2678/41	62A2146

**Table 17: 1200 mm Face - Standard Height Sign Couplings**

Size	Length	Frangible Coupling	Mounting Flange
SBKQ	1200 mm	60A2678/40	62A2142

**Figure 28: Leg Extensions**

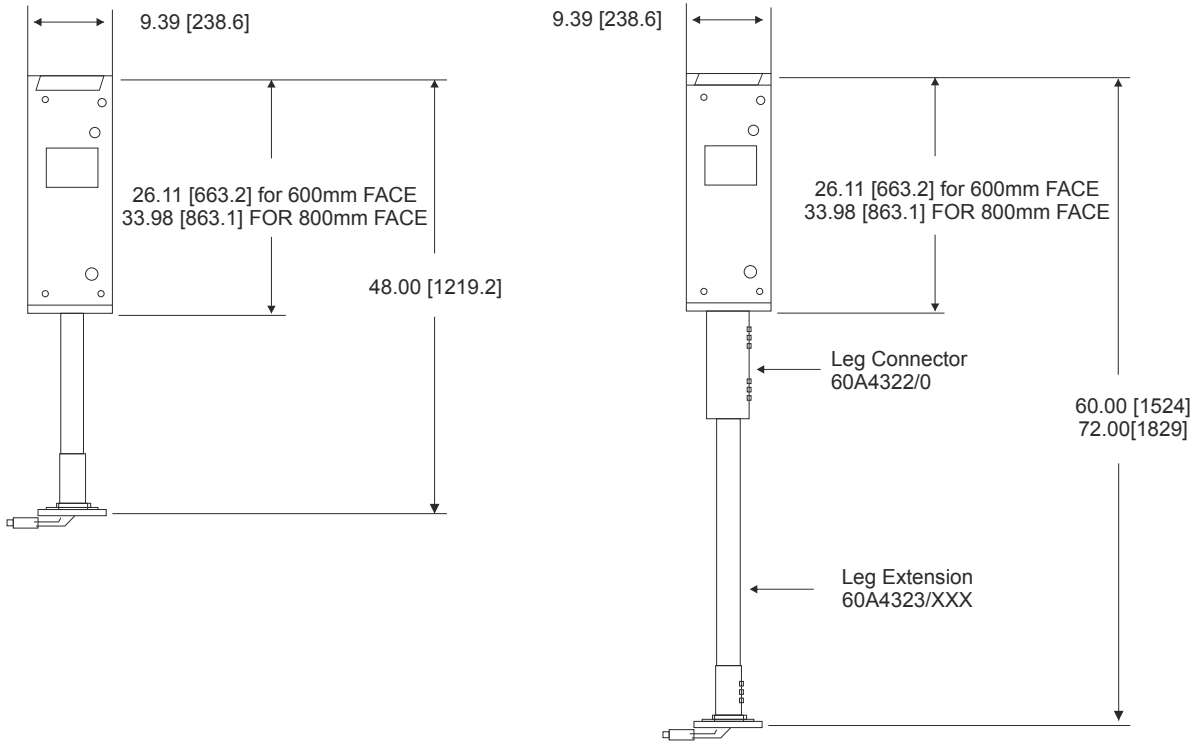

**Table 18: Cordset Usage**

DIGIT 3 - HEIGHT		DIGIT 9 - POWER	
6, 8, D, E, F, G, H, J	Sign Height	1, 2 THRU LEG	3, 4, 5, 6, 7, 8 SIDE, BOTTOM, CUSTOMER PROVIDED
SB6X	600 mm Standard	73A0107/72	73A0155/1.5
SB8X	800 mm Standard	73A0107/72	73A0155/1.5
SBDX	600 mm 48" (1219 mm) OAH	73A0107/72	73A0155/1.5
SBEX	600 mm 60" (1524 mm) OAH	73A0107/98	73A0155/2.5
SBFX	600 mm 72" (1829 mm) OAH	73A0107/98	73A0155/2.5
SBGX	800 mm 48" (1219 mm) OAH	73A0107/98	73A0155/2.5
SBHX	800 mm 60" (1524 mm) OAH	73A0107/98	73A0155/2.5
SBJX	800 mm 72" (1829 mm) OAH	73A0107/98	73A0155/2.5
SBKQ	1200 Standard	73A0107/72	73A0155/1.5

**Table 19: Cordsets**

CORD	DESCRIPTION	CONDUCTORS	JACKET DIA.
73A0107/72	L-823 C.SET FAA CLASS A TY II ST1, 72"L	16/2	0.38 in
73A0107/98	CORDSET 98" 16/2 SOW 600V ST 1 STRIPPED	16/2	0.38 in
73A0155/1.5	CORDSET 1.5 M (59") 12/2 SOW 600V ST 1	12/2	0.50 in
73A0155/2.5	CORDSET 2.5 M (98") 12/2 SOW 600V ST 1	12/2	0.50 in

## Appendix A: SUPPORT

Our experienced engineers are available for support and service at all times, 24 hour/7 days a week. They are part of a dynamic organization making sure the entire ADB SAFEGATE is committed to minimal disturbance for airport operations.

### ADB SAFEGATE Support

#### Technical Support – Global

Customers in Europe, the Middle East, Africa or Asia Pacific are more than welcome to our portal for technical support. Trained in all areas of system issues, troubleshooting, quality control and technical assistance, our highly experienced Technical support specialists are available 24 hours a day, seven days a week to provide assistance over the phone. In the Americas, we also offer live technical support.

#### Live Technical Support – Americas

If at any time you have a question or concern about your product, contact ADB SAFEGATE's US-based technical support specialists, available 24 hours a day, seven days a week, to assist you via phone.

ADB SAFEGATE Americas Technical Service & Support (US & Canada) :+1-800-545-4157

ADB SAFEGATE Americas Technical Service & Support (Canada): +1-905-631-1597

ADB SAFEGATE Americas Technical Service & Support (International): +1-614-861-1304

We can also be reached via email during regular business hours:

Airfield and Gate: [techservice.us@adbsafegate.com](mailto:techservice.us@adbsafegate.com)

Gate: [gateservice.us@adbsafegate.com](mailto:gateservice.us@adbsafegate.com)

We look forward to working with you!

#### Before You Call

When you have an airfield lighting or system control system problem, prior to calling, please ensure the following:

- Review the product's manual and troubleshooting guide.
- Be located with the product ready to troubleshoot.
- Have all necessary information available: airport code/company name, customer id number, contact phone number/email address, product/part number.
- Have a True RMS meter available and any other necessary tools.

When calling about an issue with Safedock A-VDGS, we can serve you better if you collect the following information before you call:

- Relevant information regarding the issue you are calling about, such as gate number, flight number, aircraft type and time of the event.
- What, if any, actions have been taken to resolve the issue prior to the call.
- If available, provide a CCTV recording of the incident to aid in aligning the information from the Safedock log file.



### Note

For more information, see [www.adbsafegate.com](http://www.adbsafegate.com), contact ADB SAFEGATE Support via email at [support@adbsafegate.com](mailto:support@adbsafegate.com) or Europe: +32 2 722 17 11

Americas: +1 614 861 1304. Press 3 for technical service or press 4 for sales support.

China: +86 (10) 8476 0106

Middle East and Africa: +971 4 452 7575

## A.1 ADB SAFEGATE Website

The ADB SAFEGATE website, [www.adbsafegate.com](http://www.adbsafegate.com), offers information regarding our airport solutions, products, company, news, links, downloads, references, contacts and more.

## A.2 Recycling

### A.2.1 Local Authority Recycling

The disposal of ADB SAFEGATE products is to be made at an applicable collection point for the recycling of electrical and electronic equipment. The correct disposal of equipment prevents any potential negative consequences for the environment and human health, which could otherwise be caused by inappropriate waste handling. The recycling of materials helps to conserve natural resources. For more detailed information about recycling of products, contact your local authority city office.

### A.2.2 ADB SAFEGATE Recycling

ADB SAFEGATE is fully committed to environmentally-conscious manufacturing with strict monitoring of our own processes as well as supplier components and sub-contractor operations. ADB SAFEGATE offers a recycling program for our products to all customers worldwide, whether or not the products were sold within the EU.

ADB SAFEGATE products and/or specific electrical and electronic component parts which are fully removed/separated from any customer equipment and returned will be accepted for our recycling program.

All items returned must be clearly labeled as follows:

- For RoHS/WEEE Recycling
- Sender contact information (Name, Business Address, Phone number).
- Main Unit Serial Number.

ADB SAFEGATE will continue to monitor and update according for any future requirements for EU directives as and when EU member states implement new regulations and or amendments. It is our aim to maintain our compliance plan and assist our customers.

## Company Addresses

ADB SAFEGATE, Belgium	ADB SAFEGATE BV Leuvensesteenweg 585 B-1930 Zaventem Belgium
Contact:	
Tel.: +32 2 722 17 11	Email: <a href="mailto:marketing@adbsafegate.com">marketing@adbsafegate.com</a>
Fax: +32 2 722 17 64	Internet: <a href="http://www.adbsafegate.com">www.adbsafegate.com</a>
ADB SAFEGATE, Americas	ADB SAFEGATE Americas, LLC 700 Science Blvd Gahanna, OH 43230 USA
Contact:	
Tel.: +1 (614) 861 1304	Email: <a href="mailto:sales.us@adbsafegate.com">sales.us@adbsafegate.com</a>
Fax: +1 (614) 864 2069	Internet: <a href="http://www.adbsafegate.com">www.adbsafegate.com</a>
ADB SAFEGATE, Sweden	ADB SAFEGATE Sweden AB Djurhagegatan 19 SE-213 76 Malmö Sweden
Contact:	
Tel.: +46 (0)40 699 17 00	Email: <a href="mailto:marketing@adbsafegate.com">marketing@adbsafegate.com</a>
Fax: +46 (0)40 699 17 30	Internet: <a href="http://www.adbsafegate.com">www.adbsafegate.com</a>
ADB SAFEGATE, China	ADB SAFEGATE Airfield Technologies Ltd. China Unit 603, D Block, CAMIC International Convention Center, No 3, Hua Jia Di East road, ChaoYang district, Beijing 100102 P.R. China
Contact:	
Tel.: +86 (10) 8476 0106	Email: <a href="mailto:china@safegate.com">china@safegate.com</a>
Fax: +86 (10) 8476 0090	Internet: <a href="http://www.adbsafegate.com">www.adbsafegate.com</a>
ADB SAFEGATE, Germany	ADB SAFEGATE Germany GmbH Konrad-Zuse-Ring 6, D-68163 Mannheim Germany
Contact:	
Tel.: +49 (621) 87 55 76-0	Email: <a href="mailto:marketing@adbsafegate.com">marketing@adbsafegate.com</a>
Fax: +49 (621) 87 55 76-55	Internet: <a href="http://www.adbsafegate.com">www.adbsafegate.com</a>

WWW.ADBSAFEGATE.COM

# Empowering the Airside Evolution

SMARTER. BETTER. NOW.

