



Model 8190

Motor Aspirated Radiation Shield

PRODUCT MANUAL
8190/Rev K

ADB
SAFEGATE

A.0 Disclaimer / Standard Warranty

CE certification

The equipment listed as CE certified means that the product complies with the essential requirements concerning safety and hygiene. The European directives that have been taken into consideration in the design are available on written request to ADB SAFEGATE.

ETL certification

The equipment listed as ETL certified means that the product complies with the essential requirements concerning safety and C22.2 No.180:13 (R2018) regulations. The CSA directives that have been taken into consideration in the design are available on written request to ADB SAFEGATE.

All Products Guarantee

ADB SAFEGATE will correct by repair or replacement per the applicable guarantee below, at its option, equipment or parts which fail because of mechanical, electrical or physical defects, provided that the goods have been properly handled and stored prior to installation, properly installed and properly operated after installation, and provided further that Buyer gives ADB SAFEGATE written notice of such defects after delivery of the goods to Buyer. Refer to the Safety section for more information on Material Handling Precautions and Storage precautions that must be followed.

ADB SAFEGATE reserves the right to examine goods upon which a claim is made. Said goods must be presented in the same condition as when the defect therein was discovered. ADB SAFEGATE further reserves the right to require the return of such goods to establish any claim.

ADB SAFEGATE's obligation under this guarantee is limited to making repair or replacement within a reasonable time after receipt of such written notice and does not include any other costs such as the cost of removal of defective part, installation of repaired product, labor or consequential damages of any kind, the exclusive remedy being to require such new parts to be furnished.

ADB SAFEGATE's liability under no circumstances will exceed the contract price of goods claimed to be defective. Any returns under this guarantee are to be on a transportation charges prepaid basis. For products not manufactured by, but sold by ADB SAFEGATE, warranty is limited to that extended by the original manufacturer. This is ADB SAFEGATE's sole guarantee and warranty with respect to the goods; there are no express warranties or warranties of fitness for any particular purpose or any implied warranties of fitness for any particular purpose or any implied warranties other than those made expressly herein. All such warranties being expressly disclaimed.

Standard Products Guarantee

Products manufactured by ADB SAFEGATE are guaranteed against mechanical, electrical, and physical defects (excluding lamps) which may occur during proper and normal use for a period of two years from the date of ex-works delivery, and are guaranteed to be merchantable and fit for the ordinary purposes for which such products are made.

NOTE



See your applicable sales agreement for a complete warranty description.

Replaced or repaired equipment under warranty falls into the warranty of the original delivery. No new warranty period is started for these replaced or repaired products.

FAA Certified products manufactured by ADB SAFEGATE

ADB SAFEGATE L858 Airfield Guidance Signs are warranted against mechanical and physical defects in design or manufacture for a period of 2 years from date of installation, per FAA AC 150/5345-44 (applicable edition).

ADB SAFEGATE LED products (with the exception of obstruction lighting) are warranted against electrical defects in design or manufacture of the LED or LED specific circuitry for a period of 4 years from date of installation, per FAA EB67 (applicable edition). These FAA certified constant current (series) powered LED products must be installed, interfaced and powered with and through products certified under the FAA Airfield Lighting Equipment Program (ALECP) to be included in this 4 (four) year warranty. This includes, but is not limited to, interface with products such as Base Cans, Isolation Transformers, Connectors, Wiring, and Constant Current Regulators.

Revision History

Revision	Date	Summary of Changes
J	2018 May 17	Added information to clarify two different probe-mounting procedures
K	2025 Apr 1	ADB SAFEGATE (ECP#ADBSG-0001)

Contents

1. Introduction.....	5
1.1 Models.....	5
2. Installation & Checkout	6
2.1 Mars Installation.....	6
2.2 Probe Removal And Installation.....	6
2.3 Determining The Type Of Probe Mount	7
2.4 Probe With Fixed Mount.....	9
2.4.1 Removal.....	9
2.4.2 Installation.....	10
2.5 Probe With Removable Mount.....	11
2.5.1 Removal.....	11
2.5.2 Installation.....	12
3. Theory Of Operation	13
4. Calibration	14
5. Maintenance.....	15
5.1 Periodic Maintenance.....	15
5.1.1 Monthly Maintenance.....	15
5.1.2 Triannual Maintenance	15
5.1.3 Annual Maintenance	15
6. Specifications	16
7. Warranty	17

1. Introduction

The Model 8190 Motor Aspirated Radiation Shield (MARS) provides protected mounting for temperature and humidity probes, shielding them from direct solar heating and precipitation contact. The Model 8190 series is a virtually maintenance-free radiation shield constructed of heavy-duty, noncorrosive polymer, and featuring a reliable, long-life 12 V DC fan for continuous aspiration. It accommodates one probe: a temperature probe, a humidity probe, or a combination temperature/humidity probe. All cable terminations to the MARS are made through weatherproof connectors mounted on the enclosure.

1.1 Models

The Model 8190-01 is the current model that is approved for use in the United States.

Model	Description
8190	Standard MARS
8190-01	Corrosion-Resistant MARS
8190-02	MARS for use with Model 5192 Temperature/Relative Humidity Probe
8190-03	MARS for use with Millard frangible tower

Table 1. 8190 Models

2. Installation & Checkout

The MARS is designed for tower installations. Mounting hardware is provided, including mounting brackets and U-bolts. Consult ADB Safegate. for other mounting options.

2.1 Mars Installation

Install the MARS with the vent tube on the right side, pointing down, approximately five feet above the ground. When installing the MARS on the Model 8518-A Foldover Tower, mount the MARS to the hinged side of the tower. Ensure that the probe cable will reach the Data Collection Platform connector.

The steps below summarize the installation process.

1. Lift the MARS into position and attach the horizontal tube to the tower legs using the supplied mounting brackets and U-bolts.
2. Adjust the positions of the U-bolts to give a level installation. The vertical vent tube should be vertically level to prevent direct solar radiation from entering the tube.
3. Fasten the U-bolts securely, being careful not to overtighten the horizontal tube's U-bolt, which could cause deformation of the tube.

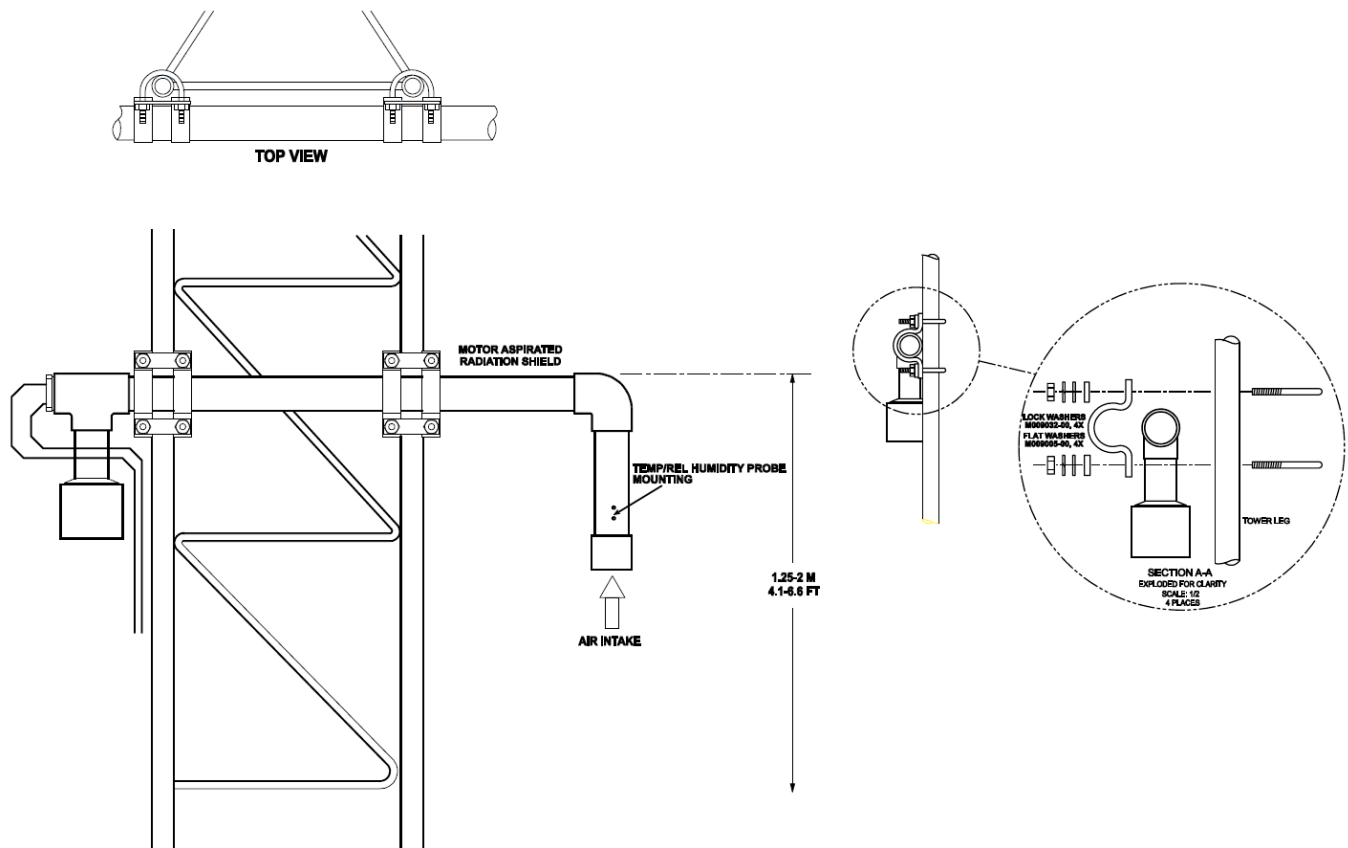

Figure 1. Mounting MARS on Tower

2.2 Probe Removal And Installation

Two different probe mounting arrangements are found on the MARS. The first method allows the probe to be removed while leaving the mounting bracket in place. The second uses mounting blocks that are attached to the probe and so are removed along with the probe. The following sections explain how to remove and install probes into the MARS in either situation.

2.3 Determining The Type Of Probe Mount

When the temperature/RH probe is installed in a fixed mount, it is removed by simply loosening the mounting screws. When the probe is installed in a removable block mount, the entire mounting block assembly must be removed along with the probe. The position of the mounting screws on the MARS is the fastest and easiest way to identify the type of probe mount.

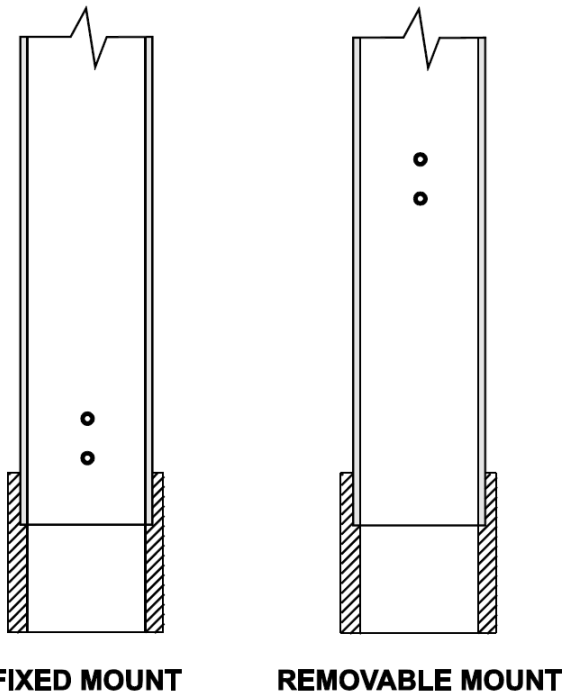
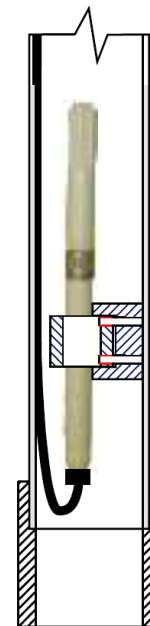

Figure 2. Determining the Type of Probe Mount



NOTE

The probe is always mounted with the filter end up, facing away from the air intake.

Model 8190 Motor Aspirated Radiation Shield

Figure 3 shows the MARS assembly to help identify the strain relief and the cables for the probe and the MARS fan. Note that the MARS fan cable is a darker gray.

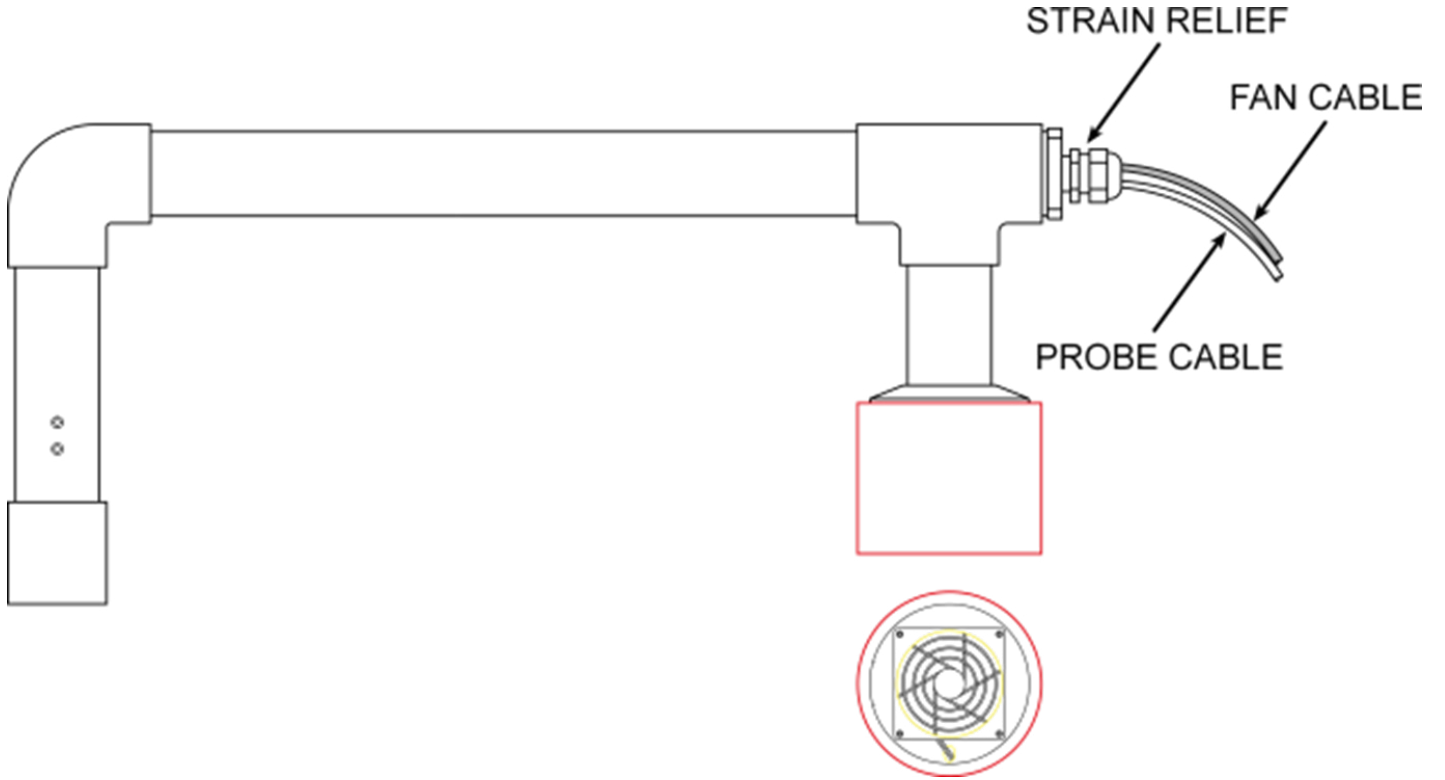

Figure 3. MARS Components for Probe Removal/Replacement

2.4 Probe With Fixed Mount

2.4.1 Removal

The probe is mounted close to the air intake of the MARS using a mounting collar and saddle arrangement that is attached with two screws on the inside of the MARS as shown in Figure 4.

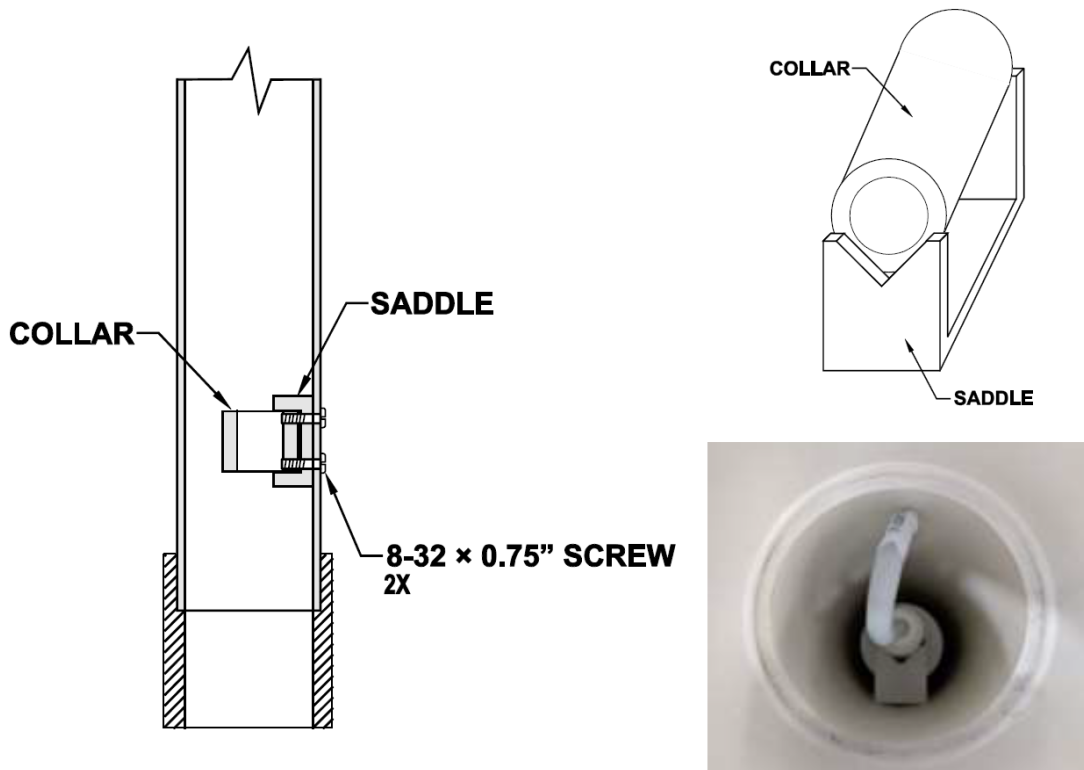

Figure 4. Probe Mounting Collar and Saddle Inside MARS

The probe can be removed by loosening the mounting screws. Do not remove the mounting hardware.

1. Disconnect power from the MARS fan. This is important to prevent electrical shock and to avoid damage to internal wiring, as well as to the fan blades. For AWOS installations, refer to the Model 1190 DCP User's Manual for instructions in connecting the MARS and the probe to the DCP.
2. Tie a piece of string to the probe cable where it emerges from the strain relief.
3. Loosen the two mounting screws 3–4 turns each. Be sure not to remove the screws completely.
4. Loosen the strain relief and, holding onto the string, grasp the probe near the bottom, above where the cable joins the case. Do not remove the probe by pulling the cable.
5. Remove the probe by pulling it gently down and out of the MARS.
6. Disconnect the cable from the probe. Leave the power to the fan disconnected.

2.4.2 Installation

1. Connect the probe cable to the probe.
2. To simplify routing of the probe cable and installation of the probe in the vent tube, feed a piece of string weighted at the end (with a nut, for example) through the horizontal tube and down through the vent tube.
3. Tie the string to the probe cable and pull the string from the opposite end to guide the cable up through the vent tube and into the horizontal tube.
4. Form a loose loop of cable at the base of the probe so that the cable forms a U (see Figure 4).
5. With the filter end of the probe pointing up, grasp the loop of cable at the base of the probe and raise the probe up into the vent tube.
6. When you feel the probe make contact with the mount, move it side-to-side as necessary until it slides into the mount opening.
7. Slide the probe into the mount until the bottom of the probe is 2–3 inches above the mouth of the MARS vent tube.
8. While holding the probe in place, tighten the mounting screws just enough to secure the probe, but do not overtighten. Overtightening the screws will damage the probe.
9. Pull the remaining slack out of the cable, keeping the cable as straight as possible.
10. Tighten the strain relief until the cable is securely sealed.
11. Route the cable down the tower in the most convenient manner. Lace or strap the cable approximately every 12 inches. Loose cables will rub against the tower in high winds, and the cable insulation could be destroyed. Use ultraviolet resistant cable ties, tape, or metal strapping. Use caution to avoid damaging the outer jacket of the cable.
12. Connect the probe cable to the data collection unit. For AWOS installations, connect the probe wires to the Data Collection Platform (DCP) as explained in the **Model 1190 DCP User's Manual**.
13. Reapply power to the MARS and check to see that the fan is rotating. Check to ensure that all mounting hardware is securely fastened. Verify probe operation.

2.5 Probe With Removable Mount

2.5.1 Removal

The probe is mounted close to the bend above the air intake of the MARS using two mounting blocks that are attached with two screws on the inside of the MARS as shown in Figure 5.

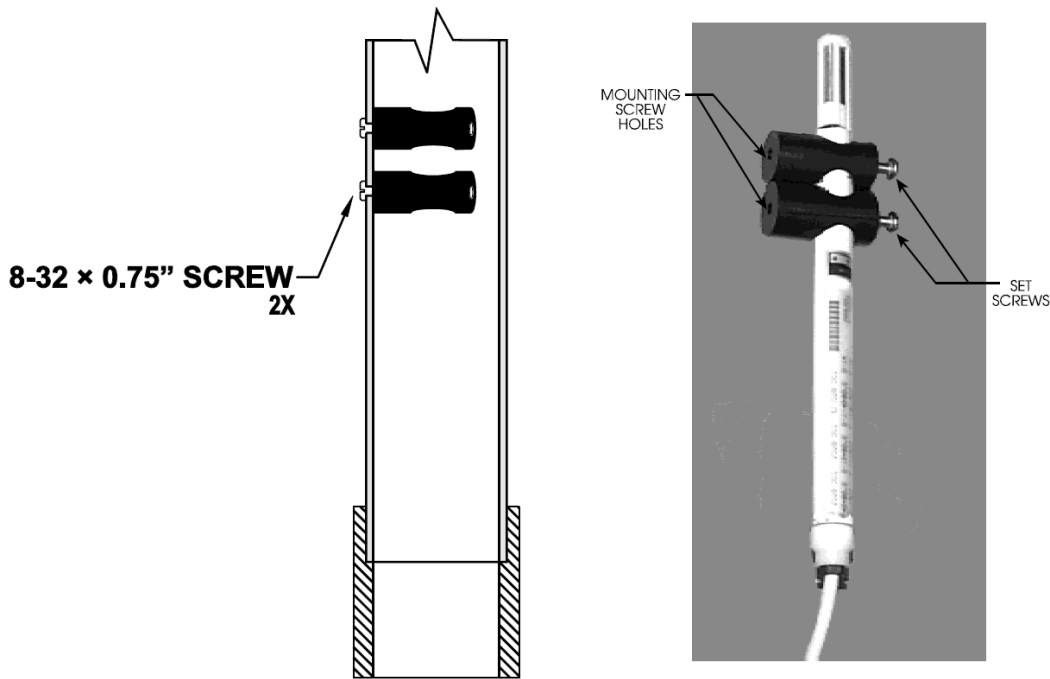

Figure 5. Installing the Probe Mounting Blocks

The mounting blocks must be removed along with the probe.

1. Disconnect power from the MARS fan. This is important to prevent electrical shock and to avoid damage to internal wiring, as well as to the fan blades. For AWOS installations, refer to the **Model 1190 DCP User's Manual** for instructions on connecting the MARS and the probe to the DCP.
2. Tie a piece of string to the probe cable where it emerges from the strain relief.
3. Remove the two mounting screws holding the probe mounting blocks in place inside the vent tube.
4. Loosen the strain relief, and, holding onto the string, lower the probe and mounting blocks out of the vent tube.
5. Disconnect the cable from the probe.
6. Remove the mounting blocks from the probe by loosening the two set screws. *Leave the power to the fan disconnected.*

2.5.2 Installation

1. Connect the probe cable to the probe.
2. Two mounting blocks are used to position the probe inside the vent tube (Figure 5). Slide the first mounting block over the probe and position it near the filter end of the probe. With the Model 5190-D probe, position the block so that the set screw is over the flattened notch in the probe case. Tighten the set screw just enough to secure the probe, but do not overtighten. Overtightening the screws will damage the probe. The mounting blocks serve only to position the probe in the center of the vent tube, not to support it inside the tube. Even with the set screws loose, there is no danger of the probe dropping out of the MARS.
3. Slide the second mounting block over the probe and up until it is flush against the first. Before tightening the set screw, make sure that the mounting screw hole on the opposite side of the block is aligned with the mounting hole in the first block. Tighten the set screws, again being careful not to overtighten.
4. To simplify routing of the probe cable and installation of the probe in the vent tube, feed a piece of string weighted at the end (with a nut, for example) through the horizontal tube and down through the vent tube.
5. Tie the string to the probe cable and pull the string from the opposite end to guide the cable up through the vent tube and into the horizontal tube.
6. Form a loose loop of cable at the base of the probe, and secure it with a cable tie so that the cable forms a U.
7. With the filter end of the probe pointing up, grasp the loop of cable at the base of the probe and raise the probe up into the vent tube. Align the screw holes in the mounting blocks with the screw holes in the vent tube.
8. Replace the two mounting screws to secure the probe mounting blocks inside the vent tube.
9. Pull the remaining slack out of the cable, keeping the cable as straight as possible.
10. Tighten the strain relief until the cable is securely sealed.
11. Route the cable down the tower in the most convenient manner. Lace or strap the cable approximately every 12 inches. Loose cables will rub against the tower in high winds, and the cable insulation could be destroyed. Use ultraviolet resistant cable ties, tape, or metal strapping. Use caution to avoid damaging the outer jacket of the cable.
12. Connect the probe cable to the data collection unit. For AWOS installations, connect the probe wires to the Data Collection Platform (DCP) as explained in the **Model 1190 DCP User's Manual**.
13. Reapply power to the MARS and check to see that the fan is rotating. Check to ensure that all mounting hardware is securely fastened. Verify probe operation.

3. Theory Of Operation

The MARS is designed to adequately ventilate a probe, while at the same time shielding it from direct and reflected solar radiation and from direct moisture contact. It is constructed of heavy-duty polymer to limit thermal mass, and thereby preventing radiant heating of temperature probes by the tubing. Highly reflective white paint is applied to all exterior surfaces to reflect as much solar radiation as possible.

Air flow through the MARS is virtually free of any obstruction. Spacing is selected to give maximum air flow and at the same time prevent direct solar contact with the probe. Fresh air is forced through the MARS by a fan to allow measurement of actual air temperature. The exhaust vent of the MARS is 44 inches from, and slightly higher than, the vent tube intake. Any heat developed by the fan motor or the shield itself will be exhausted away from the vent tube, preventing this heat from re-entering the MARS and being measured by the temperature probe.

4. Calibration

No calibration of the Model 8190 is required. To ensure constant air flow rates, periodic measurements of air flow can be made using hot wire anemometers.

5. Maintenance

Maintenance of the MARS is generally limited to periodic cleaning and occasional repainting of exterior surfaces. Instruments housed inside the MARS should be maintained according to instructions given in the manual for the particular instrument.

The basic inspections and cleaning described in this chapter may be performed by local airport personnel. Any issues identified that involve the repair or replacement of cables or fans should be referred to a certified AWOS technician when the MARS is part of a certified AWOS system.

Check the MARS for insect activity (cobwebs, hornet's nests, etc.), as well as birds' nests, and clean out any debris.

The exterior surfaces of the MARS should be free of dirt at all times to prevent internal heating of the probe. Clean the surfaces regularly with warm water and soap. Repaint the exterior surfaces as required. During regular maintenance, check the fan housing for signs of corrosion, and clean and repair, or replace as necessary. The inside of the enclosure may also need to be cleaned of excessive dirt drawn in by the fan.

Check all cables for signs of wear or damage, especially in areas with high velocity winds. Check all mounting hardware for corrosion or looseness, and repair or replace as required.

A noisy fan may be a sign of worn bearings. Replace the fan when noise is evident.

5.1 Periodic Maintenance

5.1.1 Monthly Maintenance

- Check all cables for signs of wear or damage, especially in areas with high velocity winds.
- Check the fan for noise that could be a sign of worn bearings. Replace the fan if noise is evident, or if the fan has failed.
- Check the MARS for insect activity (cobwebs, hornet's nests, etc.), as well as birds' nests, and clean out any debris.

5.1.2 Triannual Maintenance

- Check all cables for signs of wear or damage, especially in areas with high velocity winds.
- Check the fan for noise that could be a sign of worn bearings. Replace the fan if noise is evident, or if the fan has failed.
- Check all mounting hardware for corrosion or looseness, and repair or replace as required.

5.1.3 Annual Maintenance

- Clean the exterior surfaces of the MARS with warm water and soap.
- Repaint the exterior surfaces as required.
- Check all cables for signs of wear or damage, especially in areas with high velocity winds.
- Check the fan for noise that could be a sign of worn bearings. Replace the fan if noise is evident, or if the fan has failed.
- Check all mounting hardware for corrosion or looseness, and repair or replace as required.

6. Specifications

Parameter	Description
Radiation Error	0.3°C (0.5°F) @12 V DC and 1000 W/m ² solar radiation
Air Flow	110 m/min (360 ft./min) @12 V DC
Fan Life	70,000 h @ 40°C
Power Requirements	
Supply Voltage	8–15 V DC, 180mA @12V
Environmental	
Operating Temperature	-40 to +55°C (-40 to +131°F)
Mechanical	
Dimensions	107 cm L × 35 cm H × 15 cm D (42" L × 13.5" H × 6" D)
Weight	4.6 kg (10 lb)
Shipping Weight	9.5 kg (21 lb)

7. Warranty

Any defect in design, materials, or workmanship which may occur during proper and normal use during a period of 1 year from date of installation or a maximum of 2 years from shipment will be corrected by repair or replacement by ADB Safegate.

Optimizing Airside Operations From approach to take-off

SMARTER. BETTER. **NOW.**

**ADB
SAFEGATE**
www.adbsafegate.com