

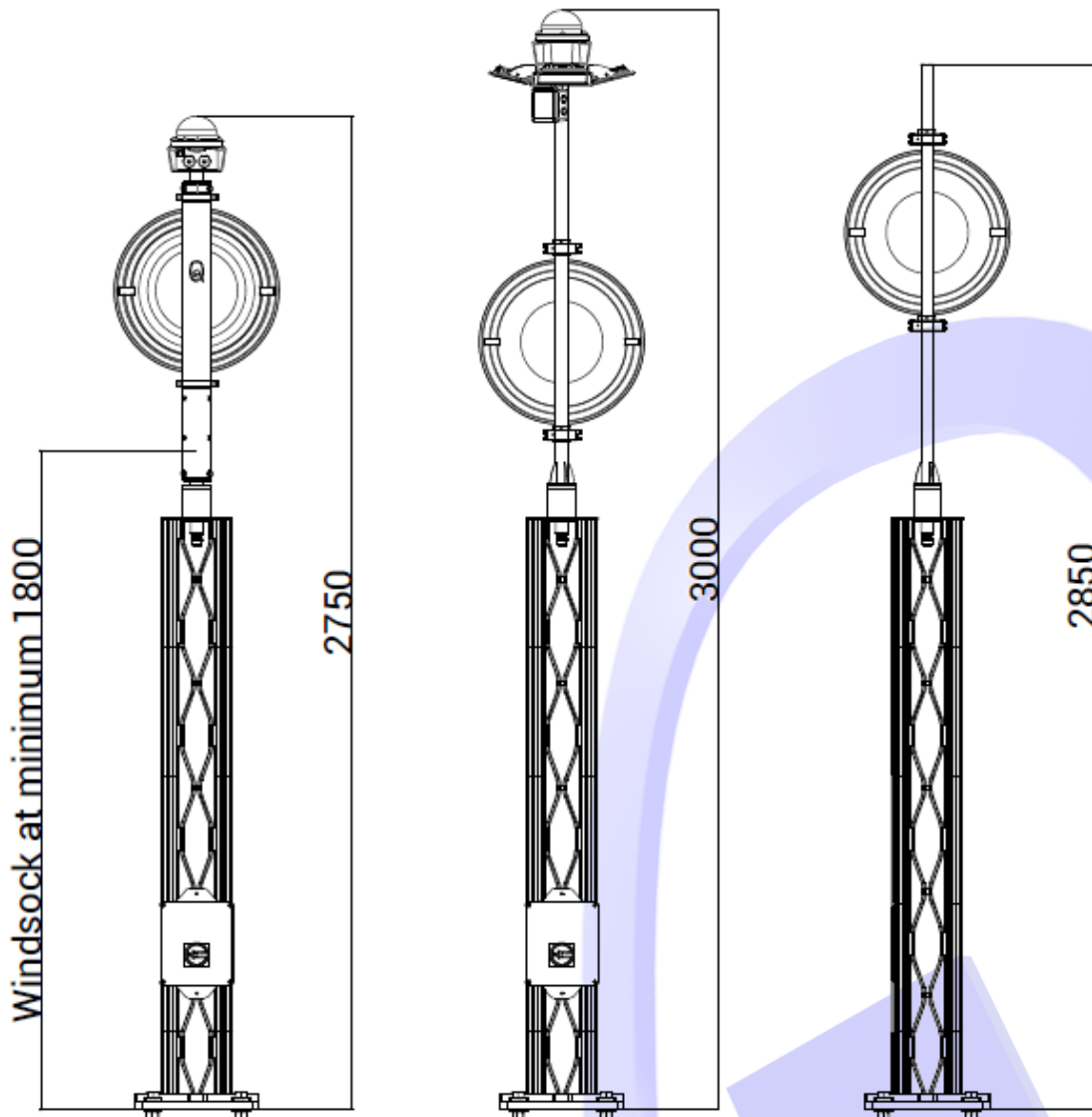

## DIMENSIONAL DRAWING

The main dimensions are displayed in the image below.



## BASE MOUNTING

The image below shows the supplied parts for mounting the base.

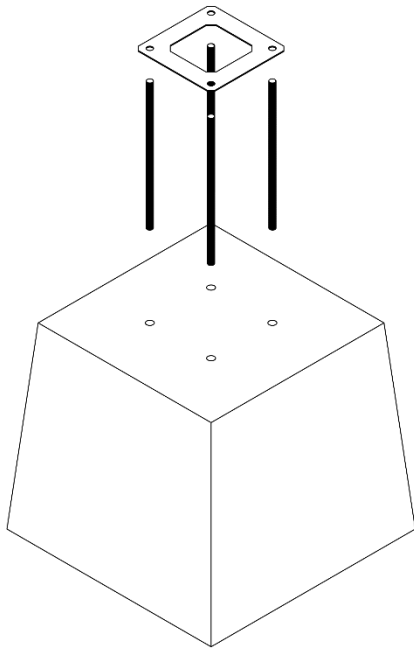

Before pouring the concrete

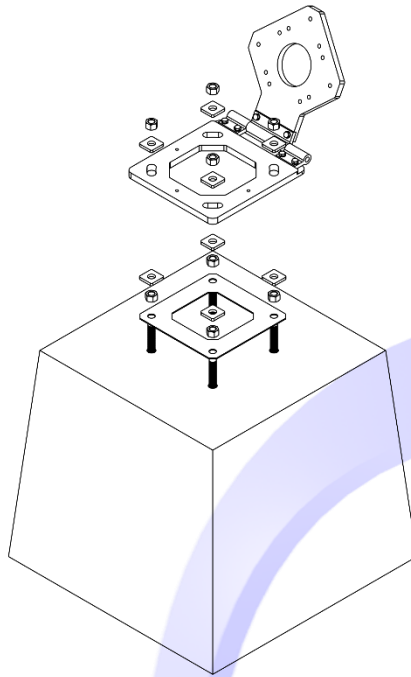

Before assembly

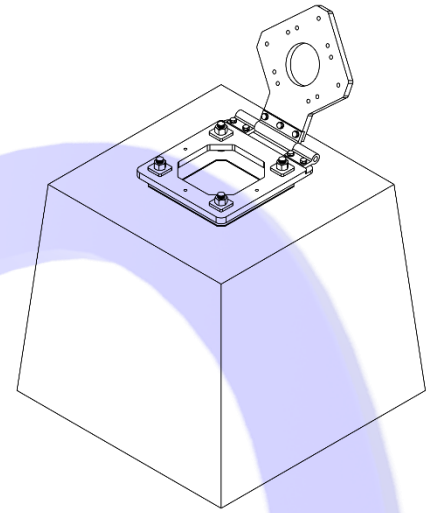

Finished base with hinge.