



**LF8 - LF9 Constant Current Regulator**  
**FERRORESONANT, AIR-COOLED**

**User Manual**

96A0488, Rev. G, 2025/05/14





## A.0 Disclaimer / Standard Warranty

### CE certification

The equipment listed as CE certified means that the product complies with the essential requirements concerning safety and hygiene. The European directives that have been taken into consideration in the design are available on written request to ADB SAFEGATE.

### ETL certification

The equipment listed as ETL certified means that the product complies with the essential requirements concerning safety and C22.2 No.180:13 (R2018) regulations. The CSA directives that have been taken into consideration in the design are available on written request to ADB SAFEGATE.

### All Products Guarantee

ADB SAFEGATE will correct by repair or replacement per the applicable guarantee below, at its option, equipment or parts which fail because of mechanical, electrical or physical defects, provided that the goods have been properly handled and stored prior to installation, properly installed and properly operated after installation, and provided further that Buyer gives ADB SAFEGATE written notice of such defects after delivery of the goods to Buyer. Refer to the Safety section for more information on Material Handling Precautions and Storage precautions that must be followed.

ADB SAFEGATE reserves the right to examine goods upon which a claim is made. Said goods must be presented in the same condition as when the defect therein was discovered. ADB SAFEGATE further reserves the right to require the return of such goods to establish any claim.

ADB SAFEGATE's obligation under this guarantee is limited to making repair or replacement within a reasonable time after receipt of such written notice and does not include any other costs such as the cost of removal of defective part, installation of repaired product, labor or consequential damages of any kind, the exclusive remedy being to require such new parts to be furnished.

ADB SAFEGATE's liability under no circumstances will exceed the contract price of goods claimed to be defective. Any returns under this guarantee are to be on a transportation charges prepaid basis. For products not manufactured by, but sold by ADB SAFEGATE, warranty is limited to that extended by the original manufacturer. This is ADB SAFEGATE's sole guarantee and warranty with respect to the goods; there are no express warranties or warranties of fitness for any particular purpose or any implied warranties of fitness for any particular purpose or any implied warranties other than those made expressly herein. All such warranties being expressly disclaimed.

### Standard Products Guarantee

Products manufactured by ADB SAFEGATE are guaranteed against mechanical, electrical, and physical defects (excluding lamps) which may occur during proper and normal use for a period of two years from the date of ex-works delivery, and are guaranteed to be merchantable and fit for the ordinary purposes for which such products are made.



### Note

See your applicable sales agreement for a complete warranty description.

Replaced or repaired equipment under warranty falls into the warranty of the original delivery. No new warranty period is started for these replaced or repaired products.

### FAA Certified products manufactured by ADB SAFEGATE

ADB SAFEGATE L858 Airfield Guidance Signs are warranted against mechanical and physical defects in design or manufacture for a period of 2 years from date of installation, per FAA AC 150/5345-44 (applicable edition).

ADB SAFEGATE LED products (with the exception of obstruction lighting) are warranted against electrical defects in design or manufacture of the LED or LED specific circuitry for a period of 4 years from date of installation, per FAA EB67 (applicable edition). These FAA certified constant current (series) powered LED products must be installed, interfaced and powered with and through products certified under the FAA Airfield Lighting Equipment Program (ALECP) to be included in this 4 (four) year warranty. This includes, but is not limited to, interface with products such as Base Cans, Isolation Transformers, Connectors, Wiring, and Constant Current Regulators.



## Note

See your sales order contract for a complete warranty description.

Replaced or repaired equipment under warranty falls into the warranty of the original delivery. No new warranty period is started for these replaced or repaired products.

---

## Liability



### WARNING

Use of the equipment in ways other than described in the catalog leaflet and the manual may result in personal injury, death, or property and equipment damage. Use this equipment only as described in the manual.

ADB SAFEGATE cannot be held responsible for injuries or damages resulting from non-standard, unintended uses of its equipment. The equipment is designed and intended only for the purpose described in the manual. Uses not described in the manual are considered unintended uses and may result in serious personal injury, death or property damage.

Unintended uses, includes the following actions:

- Making changes to equipment that have not been recommended or described in this manual or using parts that are not genuine ADB SAFEGATE replacement parts or accessories.
- Failing to make sure that auxiliary equipment complies with approval agency requirements, local codes, and all applicable safety standards if not in contradiction with the general rules.
- Using materials or auxiliary equipment that are inappropriate or incompatible with your ADB SAFEGATE equipment.
- Allowing unskilled personnel to perform any task on or with the equipment.

## Copyright Statement

This manual or parts thereof may not be reproduced, stored in a retrieval system, or transmitted, in any form or by any means, electronic, mechanical, photocopying, recording, nor otherwise, without the author's prior written consent.

This manual could contain technical inaccuracies or typographical errors. The author reserves the right to revise this manual from time to time in the contents thereof without obligation of the author to notify any person of such revision or change. Details and values given in this manual are average values and have been compiled with care. They are not binding, however, and the author disclaims any liability for damages or detriments suffered as a result of reliance on the information given herein or the use of products, processes or equipment to which this manual refers. No warranty is made that the use of the information or of the products, processes or equipment to which this manual refers will not infringe any third party's patents or rights. The information given does not release the buyer from making their own experiments and tests.

# Table of Contents

<b>1.0 Safety</b> .....	<b>1</b>
1.1 Safety Messages.....	1
1.1.1 Introduction to Safety.....	2
1.1.2 Intended Use.....	2
1.1.3 Material Handling Precautions : Storage.....	3
1.1.4 Material Handling: Heavy Equipment.....	3
1.1.5 Operation Safety.....	3
1.1.6 Maintenance Safety.....	4
1.1.7 Material Handling Precautions, ESD.....	4
1.1.8 Arc Flash and Electric Shock Hazard.....	5
<b>2.0 Ferro Constant Current Regulator</b> .....	<b>7</b>
2.1 About this manual.....	7
2.1.1 Introduction.....	7
2.1.2 How to work with the manual.....	7
<b>3.0 Ferro CCR Introduction</b> .....	<b>9</b>
3.1 Constant Current Regulator.....	9
3.2 Human Interface.....	9
3.2.1 Control Capabilities:.....	9
3.2.2 Monitoring Capabilities:.....	9
3.2.3 Communication Capabilities.....	10
3.3 Theory of Operation.....	10
<b>4.0 Installation</b> .....	<b>11</b>
4.1 Storage.....	11
4.2 Unpacking and Material Inspection.....	11
4.3 Caster Kit (94A0733) Installation.....	11
4.4 Installation Procedures.....	11
4.5 Input Power Connections.....	12
4.5.1 Field Circuit Connections.....	12
4.5.2 Control Wiring.....	13
4.5.3 Network and 24VDC Wiring.....	14
4.6 Input Power Breaker Sizing.....	15
4.7 Input Wire Size.....	15
4.8 Component Operation.....	16
4.8.1 DCMU.....	16
4.8.2 DCMU Motherboard.....	18
4.8.3 DCMU Power Supply Card.....	19
4.8.4 DCMU Input Card.....	19
4.8.5 DCMU Output Card.....	19
4.8.6 DCMU Communication Cards.....	19
4.8.7 Operator Interface.....	19
4.8.8 SCR Firing Card.....	20
4.8.9 Megger Power Supply Card.....	21
4.8.10 Megger Resistor Assembly.....	21
4.8.11 Voltage Measurements.....	21
4.8.12 Current Measurements.....	22
4.8.13 Control Transformer.....	22
4.8.14 Incoming Breaker and Contactor.....	22
4.8.15 Lightning Arrestors.....	22
<b>5.0 Operation</b> .....	<b>23</b>
5.1 Button Operation.....	23
5.1.1 Remote Button.....	23
5.1.2 Local Control Buttons.....	23
5.1.3 Fault and Warning Buttons.....	23
5.1.4 Config Button.....	24
5.1.5 Scroll and Select Buttons.....	24
5.1.6 Default Display.....	24
5.1.7 Warning and Fault Messages.....	25

5.1.8 Diagnostic Displays .....	25
5.1.9 Operations Display.....	25
5.1.10 Fault Log .....	25
5.1.11 Warning Log .....	25
5.1.12 Command Log .....	25
5.1.13 Communications Diagnostics (Port A / B).....	26
5.1.14 Raw Values .....	26
5.1.15 Firing Parameters.....	26
5.1.16 Display Diagnostics .....	26
5.1.17 Calibration Values .....	26
5.1.18 Auto Megger Control Display .....	27
5.1.19 CSS Control Display.....	27
5.1.20 Power Save Mode .....	27
5.2 Configuration.....	27
5.2.1 Navigating the Menus.....	28
5.2.2 Config Password .....	28
5.2.3 Saving Changes.....	28
5.2.4 Explanation of CCR Critical Settings .....	29
5.2.5 CCR Types.....	29
5.2.6 Min Delay.....	29
5.2.7 Max Delay.....	29
5.2.8 Low Tap Delay.....	30
5.2.9 Picket Width .....	30
5.2.10 Damping.....	30
5.2.11 Contactor Delay.....	30
5.2.12 Soft Start Feature .....	30
5.3 CCR Config Menu .....	30
5.4 Monitoring Config Menu.....	31
5.5 Comms Config Menu.....	32
5.6 CSS Config Menu.....	33
5.7 System Commands Menu .....	33
5.8 Current and Voltage Calibrations .....	35
5.8.1 Zeros .....	35
5.8.2 Output Current .....	35
5.8.3 Output Voltage .....	35
5.8.4 Input Current .....	36
5.8.5 Input Voltage.....	36
5.8.6 Output Voltage Span.....	36
5.8.7 Lamp Outage & VA Calibration.....	36
5.8.8 Lamp Outage Adjustment.....	37
5.8.9 Lamp Outage Optimization .....	37
5.8.10 Calibration from the VA Changes Menu .....	37
5.8.11 Automatic Megger Calibration .....	37
5.8.12 Calibrate for an Open.....	37
5.8.13 Calibrate for a Short .....	37
5.8.14 Calibration Values .....	38
5.9 Messages, Warnings & Faults.....	38
5.9.1 Brightness Step & Command Source .....	38
5.9.2 Actual vs Commanded Brightness.....	38
5.9.3 Warning Messages .....	39
5.9.4 Monitoring System Warnings .....	39
5.9.5 Communication Warnings .....	40
5.9.6 Circuit Selector Warnings .....	40
5.9.7 Hardware Warnings .....	40
5.9.8 Fault Messages Overview.....	41
5.9.9 Fault Messages .....	42
<b>6.0 Maintenance.....</b>	<b>45</b>
6.1 Testing & Verification .....	45
6.1.1 Testing.....	45
6.2 Troubleshooting.....	45
<b>7.0 LF8/9 CCR Parts .....</b>	<b>49</b>

---

7.1 Ordering Code.....	49
7.2 Ordering Code.....	0
7.3 CCR Kits .....	49
7.4 Ferro Parts Diagrams .....	50
7.5 Ferro Spare Parts .....	53
<b>A.0 SUPPORT .....</b>	<b>55</b>
A.1 ADB SAFEGATE Website.....	55
A.2 Recycling .....	56
A.2.1 Local Authority Recycling .....	56
A.2.2 ADB SAFEGATE Recycling .....	56

## List of Figures

Figure 1: Caster Kit Illustration .....	11
Figure 2: 120 Vac External/Internal Control .....	12
Figure 3: Ferro Wiring Diagram .....	13
Figure 4: DCMU Connections Control and Display .....	14
Figure 5: DCMU Connections for Network and Remote .....	14
Figure 6: DCMU Connections for Alarm and Safety .....	15
Figure 7: DCMU Front Panel, RS485 Communication and Bottom View .....	17
Figure 8: DCMU Left Terminal Connections Right and Left Side .....	18
Figure 9: SCR Firing Card .....	21
Figure 10: Operator Interface Display .....	23
Figure 11: Displays - Additional Data Shown By Scrolling Down .....	25
Figure 12: Display showing Door Open Trip .....	25
Figure 13: Diagnostic Display Screens .....	26
Figure 14: Auto Megger Control Screen .....	27
Figure 15: CSS Control Screen .....	27
Figure 16: Fig. 27 Configuration Menu - Scroll for More Options .....	28
Figure 17: Fig. 26 Enter Password Display .....	29
Figure 18: Typical Warning Message - No Input Voltage .....	41
Figure 19: Typical Fault Message - Door Open Trip .....	42
Figure 20: Ferro Component Plate Layout Diagram .....	50
Figure 21: DCMU - Options .....	50
Figure 22: Terminal Layout .....	51
Figure 23: Breaker Selector Chart .....	51
Figure 24: Contactor Selection Chart .....	52
Figure 25: Snubber and Transformer Selection Charts .....	52
Figure 26: Common Components Chart .....	53
Figure 27: Parts: Ferro Front Assembly .....	54
Figure 28: Parts: Ferro Side Assembly .....	54
Figure 29: Parts: Ferro cores and capacitors .....	54

## List of Tables

Table 1: Full Load Input Current .....	15
Table 2: Recommended Input Wiring Rating .....	16
Table 3: SCR Firing Card Terminals .....	20
Table 4: Output Voltage Values and Lightning Arrestor Sizes .....	22
Table 5: Default Display Information .....	24
Table 6: CCR Config Menu .....	30
Table 7: Monitoring Config Menu .....	31
Table 8: Comms Config Menu .....	32
Table 9: CSS Config Menu .....	33
Table 10: System Commands Menu .....	34
Table 11: Regulator Control Sources .....	38
Table 12: Monitoring System Warnings .....	39
Table 13: Communication Warnings .....	40
Table 14: Circuit Selector Warnings .....	40
Table 15: Hardware Warnings .....	41
Table 16: Faults .....	42
Table 17: Troubleshooting Guide .....	46
Table 18: Spare Parts .....	53

# 1.0 Safety

## Introduction to Safety

This section contains general safety instructions for installing and using ADB SAFEGATE equipment. Some safety instructions may not apply to the equipment in this manual. Task- and equipment-specific warnings are included in other sections of this manual where appropriate.

## 1.1 Safety Messages

### HAZARD Icons used in the manual

For all HAZARD symbols in use, see the Safety section. All symbols must comply with ISO and ANSI standards.

Carefully read and observe all safety instructions in this manual, which alert you to safety hazards and conditions that may result in personal injury, death or property and equipment damage and are accompanied by the symbol shown below.

	<p>WARNING Failure to observe a warning may result in personal injury, death or equipment damage.</p>
	<p>DANGER – Risk of electrical shock or ARC FLASH Disconnect equipment from line voltage. Failure to observe this warning may result in personal injury, death, or equipment damage. ARC Flash may cause blindness, severe burns or death.</p>
	<p>WARNING – Wear personal protective equipment Failure to observe may result in serious injury.</p>
	<p>WARNING – Do not touch Failure to observe this warning may result in personal injury, death, or equipment damage.</p>
	<p>CAUTION Failure to observe a caution may result in equipment damage.</p>
	<p>ELECTROSTATIC SENSITIVE DEVICES This equipment may contain electrostatic devices.</p>

### Qualified Personnel

	<p><b>Important Information</b> The term <b>qualified personnel</b> is defined here as individuals who thoroughly understand the equipment and its safe operation, maintenance and repair. Qualified personnel are physically capable of performing the required tasks, familiar with all relevant safety rules and regulations and have been trained to safely install, operate, maintain and repair the equipment. It is the responsibility of the company operating this equipment to ensure that its personnel meet these requirements.  Always use required personal protective equipment (PPE) and follow safe electrical work practice.</p>
--	--

## 1.1.1 Introduction to Safety



### CAUTION

#### Unsafe Equipment Use

This equipment may contain electrostatic devices, hazardous voltages and sharp edges on components

- Read installation instructions in their entirety before starting installation.
- Become familiar with the general safety instructions in this section of the manual before installing, operating, maintaining or repairing this equipment.
- Read and carefully follow the instructions throughout this manual for performing specific tasks and working with specific equipment.
- Make this manual available to personnel installing, operating, maintaining or repairing this equipment.
- Follow all applicable safety procedures required by your company, industry standards and government or other regulatory agencies.
- Install all electrical connections to local code.
- Use only electrical wire of sufficient gauge and insulation to handle the rated current demand. All wiring must meet local codes.
- Route electrical wiring along a protected path. Make sure they will not be damaged by moving equipment.
- Protect components from damage, wear, and harsh environment conditions.
- Allow ample room for maintenance, panel accessibility, and cover removal.
- Protect equipment with safety devices as specified by applicable safety regulations
- If safety devices must be removed for installation, install them immediately after the work is completed and check them for proper functioning prior to returning power to the circuit.

**Failure to follow this instruction can result in serious injury or equipment damage**

## Additional Reference Materials



#### Important Information

- IEC – International Standards and Conformity Assessment for all electrical, electronic and related technologies.
- IEC 60364 – Electrical Installations in Buildings.
- CSA – C22.2 No.180:13 (R2018), series isolating transformers for airport lighting.
- FAA Advisory: AC 150/5340-26 (current edition), Maintenance of Airport Visual Aid Facilities.
- Maintenance personnel must refer to the maintenance procedure described in the ICAO Airport Services Manual, Part 9.
- ANSI/NFPA 79, Electrical Standards for Metalworking Machine Tools.
- National and local electrical codes and standards.

## 1.1.2 Intended Use



### CAUTION

#### Use this equipment as intended by the manufacturer

This equipment is designed to perform a specific function, do not use this equipment for other purposes

- Using this equipment in ways other than described in this manual may result in personal injury, death or property and equipment damage. Use this equipment only as described in this manual.

**Failure to follow this instruction can result in serious injury or equipment damage**

### 1.1.3 Material Handling Precautions : Storage



#### CAUTION

##### Improper Storage

Store this equipment properly

- If equipment is to be stored prior to installation, it must be protected from the weather and kept free of condensation and dust.

**Failure to follow this instruction can result in equipment damage**

### 1.1.4 Material Handling: Heavy Equipment



#### DANGER

##### UNSTABLE LOAD

USE CAUTION WHEN MOVING HEAVY EQUIPMENT

- USE EXTREME CARE WHEN MOVING HEAVY EQUIPMENT.
- VERIFY THAT THE MOVING EQUIPMENT IS RATED TO HANDLE THE WEIGHT.
- WHEN REMOVING EQUIPMENT FROM A SHIPPING PALLET, CAREFULLY BALANCE AND SECURE IT USING A SAFETY STRAP.

**FAILURE TO FOLLOW THIS INSTRUCTION CAN RESULT IN DEATH, SERIOUS INJURY, OR EQUIPMENT DAMAGE**

### 1.1.5 Operation Safety



#### CAUTION

##### Improper Operation

Do Not Operate this equipment other than as specified by the manufacturer

- Only qualified personnel, physically capable of operating the equipment and with no impairments in their judgment or reaction times, should operate this equipment.
- Read all system component manuals before operating this equipment. A thorough understanding of system components and their operation will help you operate the system safely and efficiently.
- Before starting this equipment, check all safety interlocks, fire-detection systems, and protective devices such as panels and covers. Make sure all devices are fully functional. Do not operate the system if these devices are not working properly. Do not deactivate or bypass automatic safety interlocks or locked-out electrical disconnects or pneumatic valves.
- Protect equipment with safety devices as specified by applicable safety regulations.
- If safety devices must be removed for installation, install them immediately after the work is completed and check them for proper functioning.
- Route electrical wiring along a protected path. Make sure they will not be damaged by moving equipment.
- Never operate equipment with a known malfunction.
- Do not attempt to operate or service electrical equipment if standing water is present.
- Use this equipment only in the environments for which it is rated. Do not operate this equipment in humid, flammable, or explosive environments unless it has been rated for safe operation in these environments.
- Never touch exposed electrical connections on equipment while the power is ON.

**Failure to follow these instructions can result in equipment damage**

## 1.1.6 Maintenance Safety



### **DANGER**

#### **ELECTRIC SHOCK HAZARD**

THIS EQUIPMENT MAY CONTAIN ELECTROSTATIC DEVICES

- DO NOT OPERATE A SYSTEM THAT CONTAINS MALFUNCTIONING COMPONENTS. IF A COMPONENT MALFUNCTIONS, TURN THE SYSTEM OFF IMMEDIATELY.
- DISCONNECT AND LOCK OUT ELECTRICAL POWER.
- ALLOW ONLY QUALIFIED PERSONNEL TO MAKE REPAIRS. REPAIR OR REPLACE THE MALFUNCTIONING COMPONENT ACCORDING TO INSTRUCTIONS PROVIDED IN ITS MANUAL.

**FAILURE TO FOLLOW THESE INSTRUCTIONS CAN RESULT IN DEATH OR EQUIPMENT DAMAGE**

## 1.1.7 Material Handling Precautions, ESD



### **CAUTION**

#### **Electrostatic Sensitive Devices**

This equipment may contain electrostatic devices

- Protect from electrostatic discharge.
- Electronic modules and components should be touched only when this is unavoidable e.g. soldering, replacement.
- Before touching any component of the cabinet you shall bring your body to the same potential as the cabinet by touching a conductive earthed part of the cabinet.
- Electronic modules or components must not be brought in contact with highly insulating materials such as plastic sheets, synthetic fiber clothing. They must be laid down on conductive surfaces.
- The tip of the soldering iron must be grounded.
- Electronic modules and components must be stored and transported in conductive packing.

**Failure to follow this instruction can result in equipment damage**

## 1.1.8 Arc Flash and Electric Shock Hazard



### **DANGER**

#### **SERIES CIRCUITS HAVE HAZARDOUS VOLTAGES**

THIS EQUIPMENT PRODUCES HIGH VOLTAGES TO MAINTAIN THE SPECIFIED CURRENT - DO NOT DISCONNECT WHILE ENERGIZED.

- ALLOW ONLY QUALIFIED PERSONNEL TO PERFORM MAINTENANCE, TROUBLESHOOTING, AND REPAIR TASKS.
- ONLY PERSONS WHO ARE PROPERLY TRAINED AND FAMILIAR WITH ADB SAFEGATE EQUIPMENT ARE PERMITTED TO SERVICE THIS EQUIPMENT.
- AN OPEN AIRFIELD CURRENT CIRCUIT IS CAPABLE OF GENERATING >5000 VAC AND MAY APPEAR OFF TO A METER.
- NEVER UNPLUG A DEVICE FROM A CONSTANT CURRENT CIRCUIT WHILE IT IS OPERATING; ARC FLASH MAY RESULT.
- DISCONNECT AND LOCK OUT ELECTRICAL POWER.
- ALWAYS USE SAFETY DEVICES WHEN WORKING ON THIS EQUIPMENT.
- FOLLOW THE RECOMMENDED MAINTENANCE PROCEDURES IN THE PRODUCT MANUALS.
- DO NOT SERVICE OR ADJUST ANY EQUIPMENT UNLESS ANOTHER PERSON TRAINED IN FIRST AID AND CPR IS PRESENT.
- CONNECT ALL DISCONNECTED EQUIPMENT GROUND CABLES AND WIRES AFTER SERVICING EQUIPMENT. GROUND ALL CONDUCTIVE EQUIPMENT.
- USE ONLY APPROVED ADB SAFEGATE REPLACEMENT PARTS. USING UNAPPROVED PARTS OR MAKING UNAPPROVED MODIFICATIONS TO EQUIPMENT MAY VOID AGENCY APPROVALS AND CREATE SAFETY HAZARDS.
- CHECK THE INTERLOCK SYSTEMS PERIODICALLY TO ENSURE THEIR EFFECTIVENESS.
- DO NOT ATTEMPT TO SERVICE ELECTRICAL EQUIPMENT IF STANDING WATER IS PRESENT. USE CAUTION WHEN SERVICING ELECTRICAL EQUIPMENT IN A HIGH-HUMIDITY ENVIRONMENT.
- USE TOOLS WITH INSULATED HANDLES WHEN WORKING WITH AIRFIELD ELECTRICAL EQUIPMENT.

**FAILURE TO FOLLOW THESE INSTRUCTIONS CAN RESULT IN DEATH OR EQUIPMENT DAMAGE**



## 2.0 Ferro Constant Current Regulator

The CCR provides a constant current output (6.6A) to power airfield lighting series circuits used for runways, taxiways and approach lighting systems. The CCR has built-in monitoring and failsafe capabilities and meets the requirements of FAA L-828 and L-829 specifications. The CCR utilizes a distributed architecture and can be provided with redundant Ethernet or serial communication to an Airfield Lighting Control and Monitoring System (ALCMS). This instruction manual provides the information necessary to install, operate and maintain the CCR. If Integral L-847 Circuit Selector Switch Options 52 or 53 are provided, refer to The ADB SAFEGATE Product Center for additional information.



## 2.1 About this manual

### 2.1.1 Introduction

This manual is based on the menus and features that are included in equipment specifications. There may be some minor differences in various versions, however the manual will generally be applicable.

### 2.1.2 How to work with the manual

- Become familiar with the structure and content.
- Carry out the actions completely and in the given sequence.



## 3.0 Ferro CCR Introduction

The LF8/LF9 Ferro Constant Current Regulator (CCR) was designed to provide an economical solution for powering airfield lighting series circuits at General Aviation and commercial airports. With powerful control and monitoring capabilities, it is also ideally suited for airports operating in CAT II or III conditions.

Ferro type regulators are the most common type of CCR installed around the world, largely due to the low cost, high reliability and years of field-proven experience.



### Note

Thyristor CCRs can be used on any airfield circuit, however ferroresonant CCRs are recommended for circuits with oscillating loads.

## 3.1 Constant Current Regulator

### Compliance with Standards

<b>FAA:</b>	L-828/L-829 AC 150/5345-10 (Current Edition)
<b>ICAO:</b>	Aerodrome Design Manual Part 5, para. 3.2.1.4 to 3.2.1.6.
<b>T/C:</b>	Transport Canada CCR Specification K290-2. Canadian Department of National Defense Standards.

### Uses

Supplies three or five precision output levels to power series lighting circuits on airport runways and taxiways.

### Overview

The LF8/LF9 Ferroresonant Constant Current Regulator (CCR) was designed to provide an economical solution for powering airfield lighting series circuits at General Aviation and commercial airports. With powerful control and monitoring capabilities, it is also ideally suited for airports operating in CAT II or III conditions.

## 3.2 Human Interface

### 3.2.1 Control Capabilities:

- Operated locally from keypad or from remote source (airfield lighting control system).
- Five brightness step control of CCR plus non-illuminating brightness step for SMGCS applications or PAPI warning (frost prevention).
- Support for 24VDC, 48VDC or 120VAC control supplied internally (CCR) or externally (control system).
- Programmable failsafe capabilities allows last state (latching) or preset brightness selection upon failure of control system or DCMU.

### 3.2.2 Monitoring Capabilities:

- Current status including commanded and actual brightness, warning and fault conditions (door interlock, primary power, remote switch position, over-current and open circuit trips).
- Analog monitoring of input and output current, voltage, VA, power, power factor, efficiency, brightness within specifications, number of failed lamps per circuit including warning and alarm indication.
- Insulation resistance to ground (automatic megger) and ground fault alarm indications.
- Elapsed time at each brightness and total operations.
- Monitoring and alarming of each DCMU power supply and communication channel.
- Redundant 24VDC power inputs for backup power allows monitoring and indication even on power failure to the CCR. Range is 18VDC to 30VDC.

### 3.2.3 Communication Capabilities

- Available in standard and redundant versions using 100MB Ethernet networks with Modbus/TCP or Ethernet/IP Protocols.
- Available in standard and redundant versions using RS485 networks with Modbus or DF1 Protocols

## 3.3 Theory of Operation

The SCR type regulator is designed to maintain a constant current output into airfield lighting circuits. Power is connected to the line side of the main contactor. When the contactor is energized, power is supplied to a pair of thyristors (also called SCRs) which are connected to the primary winding of the output transformer. The airfield lighting circuit is connected to the high voltage secondary terminals of the output transformer.

An SCR functions as a controlled diode, and is a one-way switch. When used with AC circuits, a pair of SCRs are needed, and are installed back-to-back. With this arrangement, one SCR of the pair will conduct on the AC sine wave positive half of the applied waveform, the other SCR on the negative half. In the off state, with AC voltage applied across anode and cathode, the thyristor will not conduct. When the applied voltage on the anode is positive with respect to the cathode, and the SCR is turned on with a gate signal the SCR will start to conduct.

Once the thyristor starts conducting, it continues to conduct for the rest of the AC half-cycle. It will automatically stop conducting when the current reaches zero, and will not start conducting again until another gate pulse is applied during the next positive half-cycle. The amount of power that will flow to the load through the SCRs is controlled by turning on the SCR pair with the gate pulse earlier or later each half-cycle.

The SCR type CCR will have excellent regulation, and will not be affected by changes to the supply power or to the output circuit. and the output increases.

## 4.0 Installation

Provides the detailed procedures required to safely and correctly install, integrate, calibrate, align, and confirm (i.e. checkout) performance of the product.

### 4.1 Storage

Procedures for proper storage of the product on a shelf or in a warehouse. Solar products require unpacking prior to storage.

### 4.2 Unpacking and Material Inspection

The regulator is tested and carefully packed before being shipped. Unpack the regulator, open the enclosure doors and inspect for any damage that has occurred in shipment.

If there is any damage to the enclosure or internal components, notify the shipping company immediately.

### 4.3 Caster Kit (94A0733) Installation

Figure 1: Caster Kit Illustration

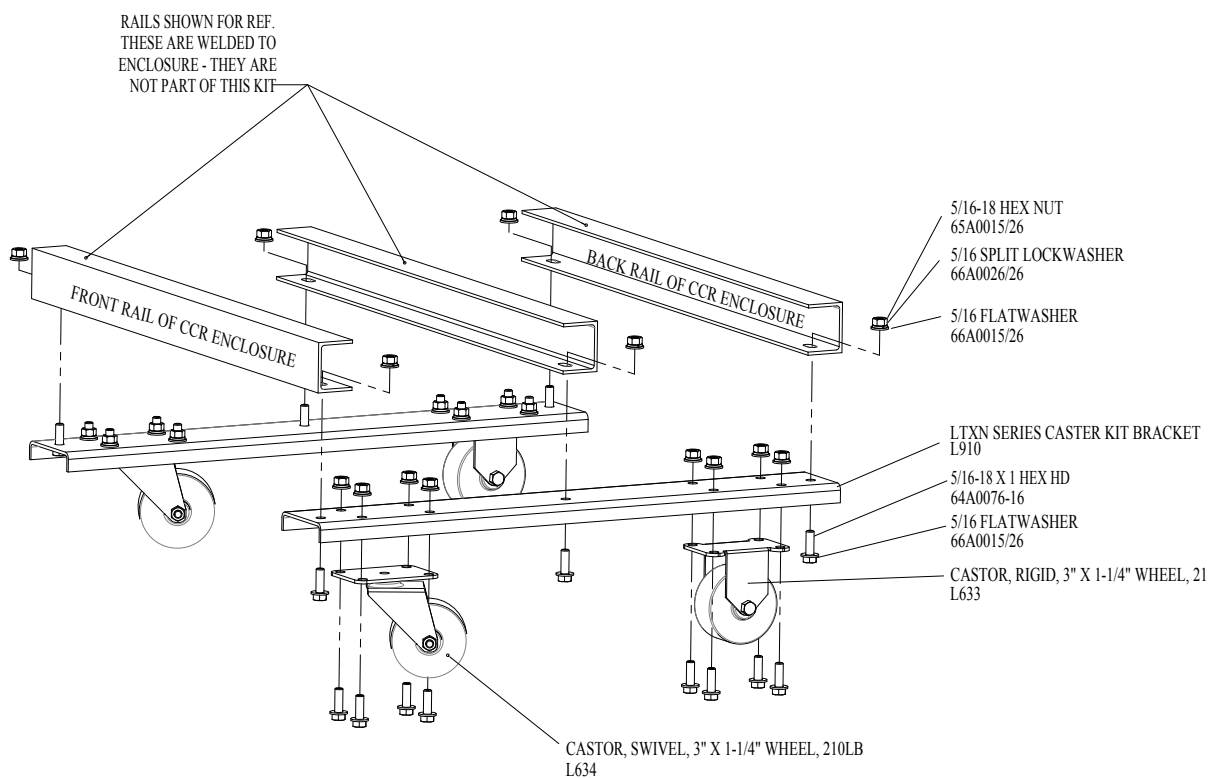

1. Lift the CCT onto blocks or use a forklift to hold the CCR at least 8-inches (203mm) above the ground.
2. Align the CASTER MTG BRACKET holes with the holes at the base of the CCR.
3. Slide in the CASTER.
4. Use the casters on the front of the assembly and the rigid casters on the back of the assembly.
5. Place the (15 mm) 5/16" SPLIT LOCKWASHER, and the (13mm) 5/16"-18 HX NUT onto the Caster Stem and tighten. Torque to 491 in-lbs. (55.5 N•m) minimum.

## 4.4 Installation Procedures

Follow all local and national electrical codes for installation and mounting of electrical equipment.

Install the CCR in a suitable location within the electrical vault. CCRs can be placed on the floor, on mounting channels or on a raised concrete pad. CCRs rated from 1KW to 7.5KW can also be mounted on the wall. Anchor to the floor if required to meet local or seismic requirements.

If desired, regulators rated up to 15KW can be stacked three units high using the floor mounting / stacking C-channels. Regulators rated from 20KW to 30KW can be stacked two units high.

## 4.5 Input Power Connections

Regulators are designed to be individually fed from circuit breakers located in a panel board in the electrical vault.

Select and remove the desired knock-out on the side or top of the regulator. Install conduit between the regulator and the panel board, sized to meet applicable electrical codes.

Using properly sized wire meeting applicable electrical codes, connect the breaker in the panel board to the line side of the contactor or internal breaker (if provided) as indicated on drawings. Connect a ground wire to the ground lug provided within the enclosure.

**Figure 2: 120 Vac External/Internal Control**

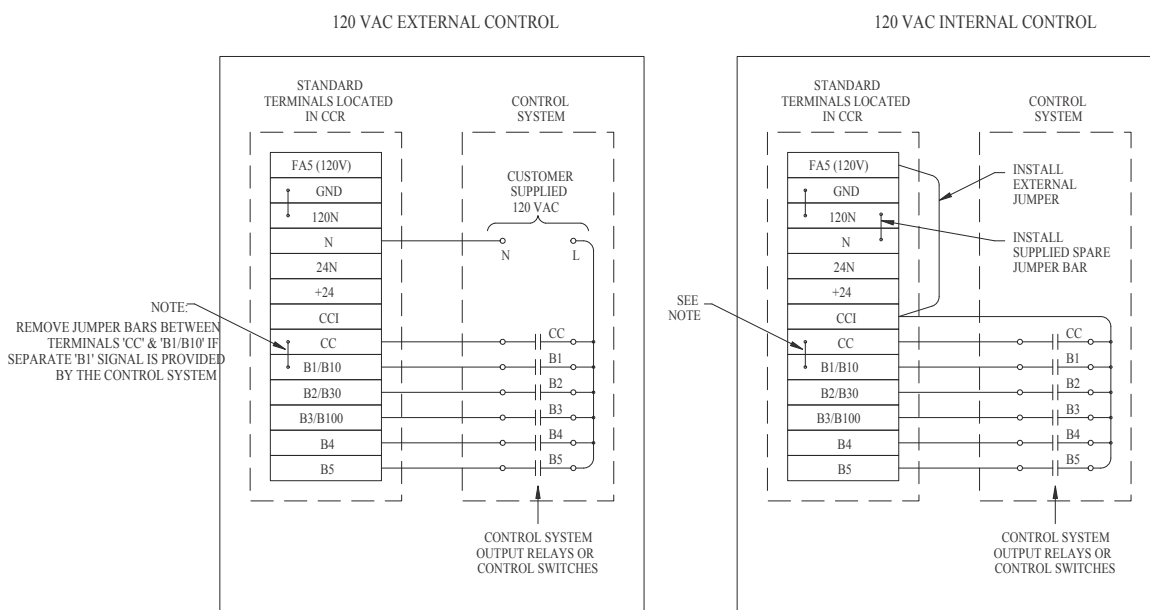

 <p>THE INFORMATION CONTAINED HEREON IS THE PROPERTY OF ADB SAFEGATE AND MUST BE MAINTAINED IN CONFIDENCE. NO PORTION OF THIS DRAWING MAY BE REPRODUCED OR USED, WITHOUT THE EXPRESS PERMISSION OF THE COMPANY.</p>	ADB SAFEGATE - COLUMBUS - OHIO SPIRIT SERIES - THYRISTOR TYPE CONSTANT CURRENT REGULATOR (CCR) WIRING DIAGRAM - CONTROL CONNECTIONS		ADBS-WD-004
	DRAWN: SGS NOV. 28/16	DIMS: N/A	
	FILE: ADBS-WD-004D.dwg	SIZE:	
	SCALE:	APRVD:	

### 4.5.1 Field Circuit Connections

Select and remove the desired knock-out on the side or bottom of the regulator.

Using #8 AWG Airfield Lighting cable (#6 AWG for 20A circuits), connect the field circuit to the output of the regulator. This will be to an integral field circuit isolator (S1 Cutout) or directly to the output lightning arrestors if an S1 is not provided.

If Integral L-847 Circuit Selector Switch Options 52 or 53 are provided, the field cables will connect to high voltage insulated standoffs, one pair per field circuit.

**Figure 3: Ferro Wiring Diagram**

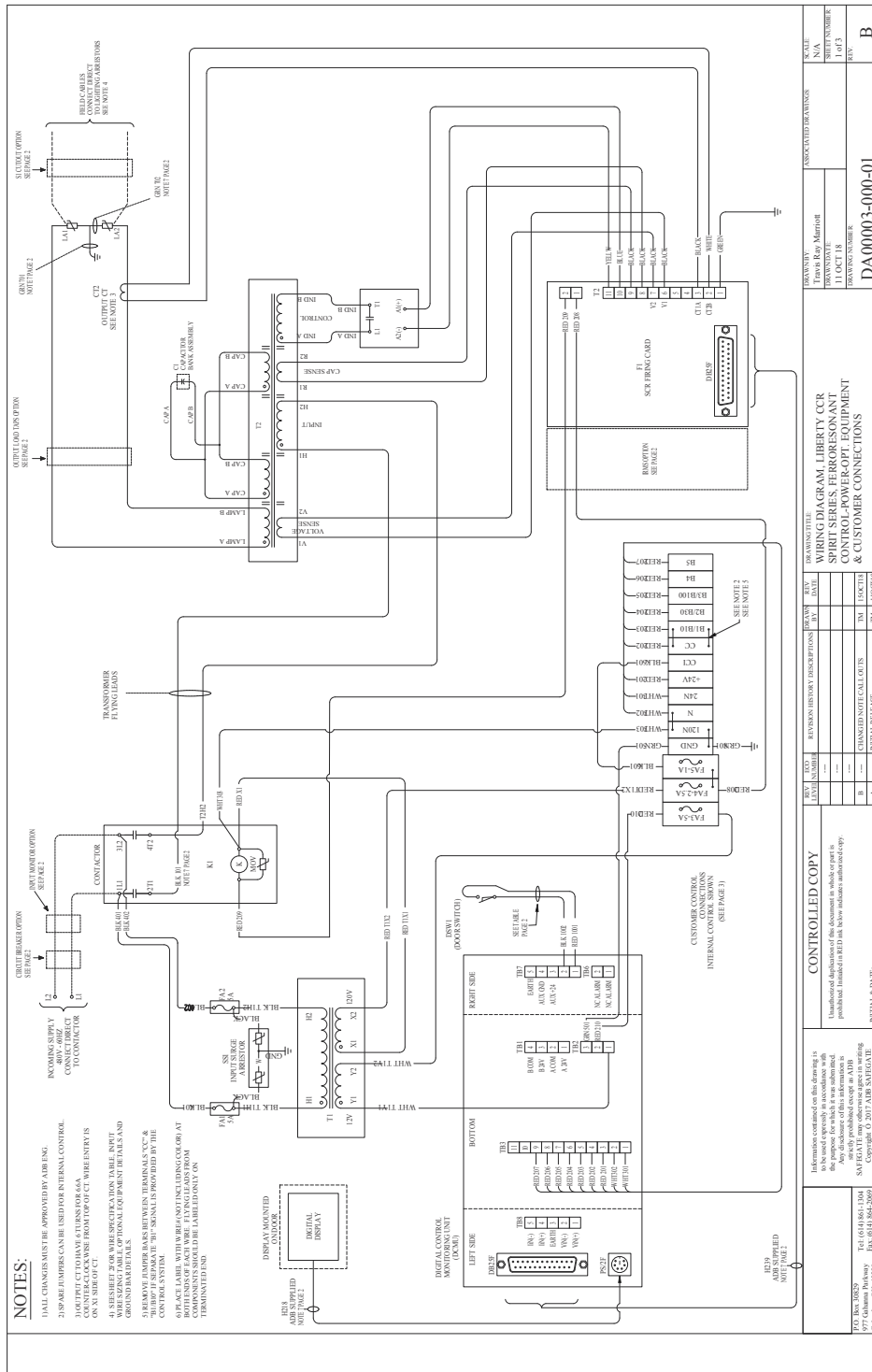

### 4.5.2 Control Wiring

If the control system will be providing parallel output wires to turn on the regulator and change brightness steps, install conduit as required between the regulator and the control system panel.

Using multi-conductor control cable, #18 to #22 AWG, route the cable through the conduit (as applicable) and terminate as indicated on the drawings.

If Integral L-847 Circuit Selector Switch Options 52 or 53 are provided, refer to Instruction Manual LAS-IB- 014 for additional information.

**Figure 4: DCMU Connections Control and Display**

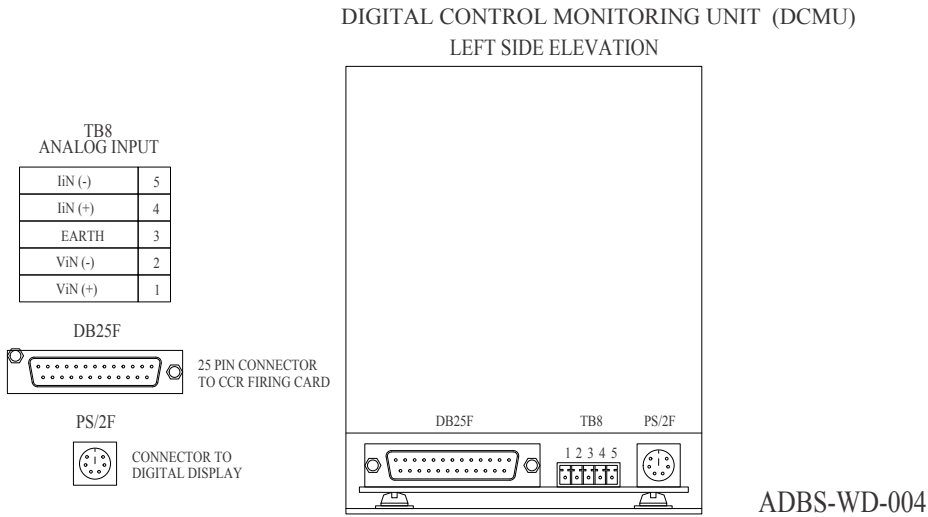

### 4.5.3 Network and 24VDC Wiring

If the control system will be using a communication network to turn on the regulator and change brightness steps, install conduit as required between the regulator and the control system panel.

Install communication wiring and 24VDC backup power wiring back to the Airfield Lighting Control System. 24VDC and RS485 communication wiring can be daisy-chained from one DCMU to the next. Ethernet CAT5e cables must be run back to a central Ethernet switch. Refer to project specific drawings for details.

**Figure 5: DCMU Connections for Network and Remote**

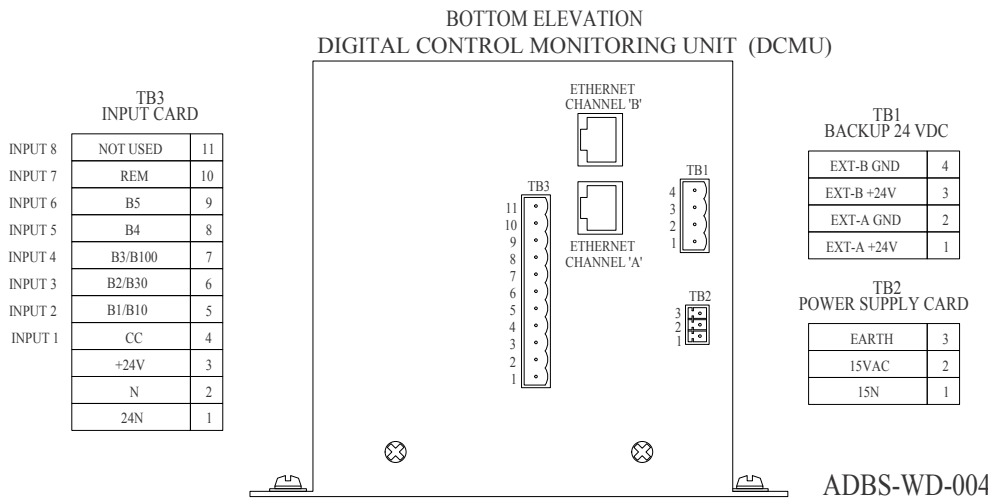

**Figure 6: DCMU Connections for Alarm and Safety**

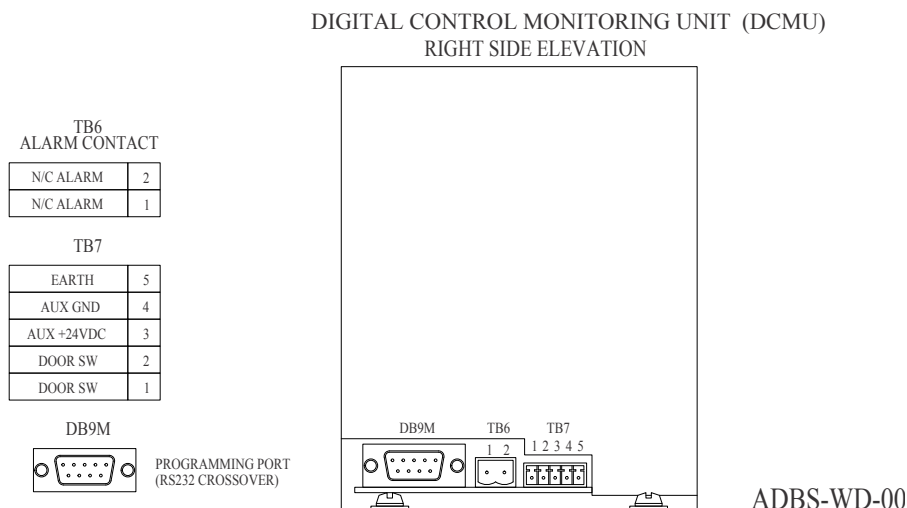

## 4.6 Input Power Breaker Sizing



### CAUTION

The supply circuit should be protected with a circuit breaker with an amperage rating slightly higher (e.g., typically 15-25%) than the full load current of the CCR.



### CAUTION

Always observe local electrical codes and ordinances when selecting a circuit protection device.



### Note

The currents listed in the table below represents input currents assuming the worst case limits of AC 150/5345-10 for low line power factor, efficiency, and the maximum allowable load of open circuited isolation transformers while running at full load and the highest output step.

**Table 1: Full Load Input Current**

SIZE	208 V	220 V	230 V	240 V	347 V	380 V	400 V	480 V	600 V
2.5 kW	17 A	16 A	15 A	15 A	10 A	9 A	9 A	7 A	6 A
4 kW	27 A	26 A	25 A	24 A	16 A	15 A	14 A	12 A	9 A
5 kW	34 A	32 A	31 A	30 A	20 A	19 A	18 A	15 A	12 A
7.5 kW	51 A	48 A	46 A	44 A	31 A	28 A	27 A	22 A	18 A
10 kW	68 A	65 A	62 A	59 A	41 A	37 A	35 A	30 A	24 A
15 kW	97 A	92 A	88 A	84 A	58 A	53 A	50 A	42 A	34 A
20 kW	129 A	122 A	117 A	112 A	78 A	71 A	67 A	56 A	45 A
25 kW	162 A	153 A	146 A	140 A	97 A	88 A	84 A	70 A	56 A
30 kW	190 A	179 A	172 A	164 A	114 A	104 A	99 A	82 A	66 A

## 4.7 Input Wire Size

The following table lists the recommended input power supply wire size for each regulator power rating dependent on the input voltage. This recommendation is based on 75°C rated copper wire per NEC Table 310.16.

**Table 2: Recommended Input Wiring Rating**

SIZE	208 V	220 V	230 V	240 V	347 V	380 V	400 V	480 V	600 V
2.5 kW	AWG 12	AWG 12	AWG 12*	AWG 12*	AWG 12	AWG 12*	AWG 12*	AWG 12	AWG 12
4 kW	AWG 12	AWG 12	AWG 12*	AWG 12*	AWG 12	AWG 12*	AWG 12*	AWG 12	AWG 12
5 kW	AWG 12	AWG 12	AWG 12	AWG 12	AWG 12*	AWG 12*	AWG 12*	AWG 12	AWG 12
7.5 kW	AWG 8	AWG 8	AWG 8	AWG 8	AWG 10	AWG 10	AWG 10	AWG 10*	AWG 10*
10 kW	AWG 8	AWG 8	AWG 8	AWG 8	AWG 8	AWG 8	AWG 8	AWG 8	AWG 8
15 kW	AWG 4	AWG 4	AWG 4	AWG 6	AWG 6	AWG 6	AWG 6	AWG 6	AWG 6
20 kW	AWG 1/0	AWG 1/0	AWG 1/0	AWG 2	AWG 2	AWG 2	AWG 2	AWG 6	AWG 6
25 kW	AWG 1/0	AWG 1/0	AWG 1/0	AWG 2	AWG 2	AWG 2	AWG 2	AWG 6	AWG 6
30 kW	AWG 1/0	AWG 1/0	AWG 1/0	AWG 2/0	AWG 2	AWG 2	AWG 2	AWG 6	AWG 6
*Increased 1 wire size to comply with small conductor limits in NEC 240.4(E) through (G)									

## 4.8 Component Operation

### Hardware Components

The regulator includes the following main components installed within the regulator enclosure:

- Distributed Control & Monitoring Unit (DCMU).
- Operator interface (display & membrane keypad).
- SCR control card, Dual SCR Module and snubber card.
- Automatic megger power supply card and megger resistor assembly (optional).
- Output transformer, current transformer(s).
- Incoming circuit breaker (optional), contactor
- Step-down control transformer and fuses.
- Input and Output lightning arrestors.

### 4.8.1 DCMU

The DCMU is made up of a number of printed circuit boards installed in a black metallic enclosure. Each circuit board provides a different function within the system. Terminal blocks are provided for external connections, and LED indicators provide status and diagnostic information. The Digital Controller Label on the front of the DCMU indicates the functions that are provided and depending on your particular application, may be different than shown below.

The main motherboard contains a Digital Signal Processor (industrial grade microprocessor) and flash memory to store the firmware configuration and calibration settings.

**Figure 7: DCMU Front Panel, RS485 Communication and Bottom View**

**DIGITAL CONTROL MONITORING UNIT (DCMU) CONNECTIONS**

**FRONT ELEVATION**

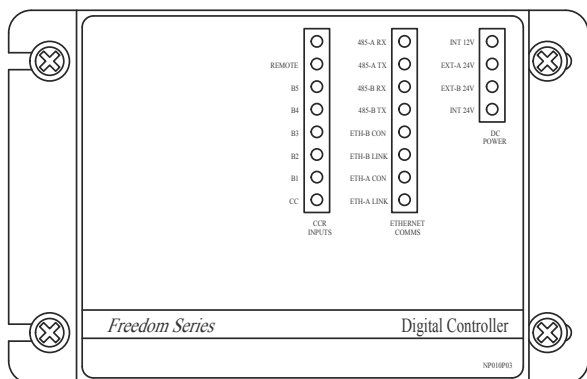

**BOTTOM ELEVATION**

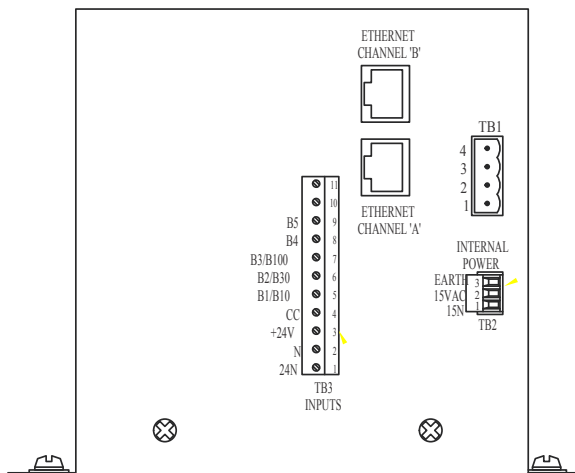

NOTE:  
FOR ITEM NUMBERS REFER TO  
Spare Parts

**ADBS-PA-00**

Five additional circuit cards can be plugged into the main motherboard. These include a power supply card, communications card (either RS485 or Ethernet), 1 or 2 input cards, and 1 or 2 latching relay output cards. The figures below show the cards and connectors that are most commonly provided for this application.

**Figure 8: DCMU Left Terminal Connections Right and Left Side**

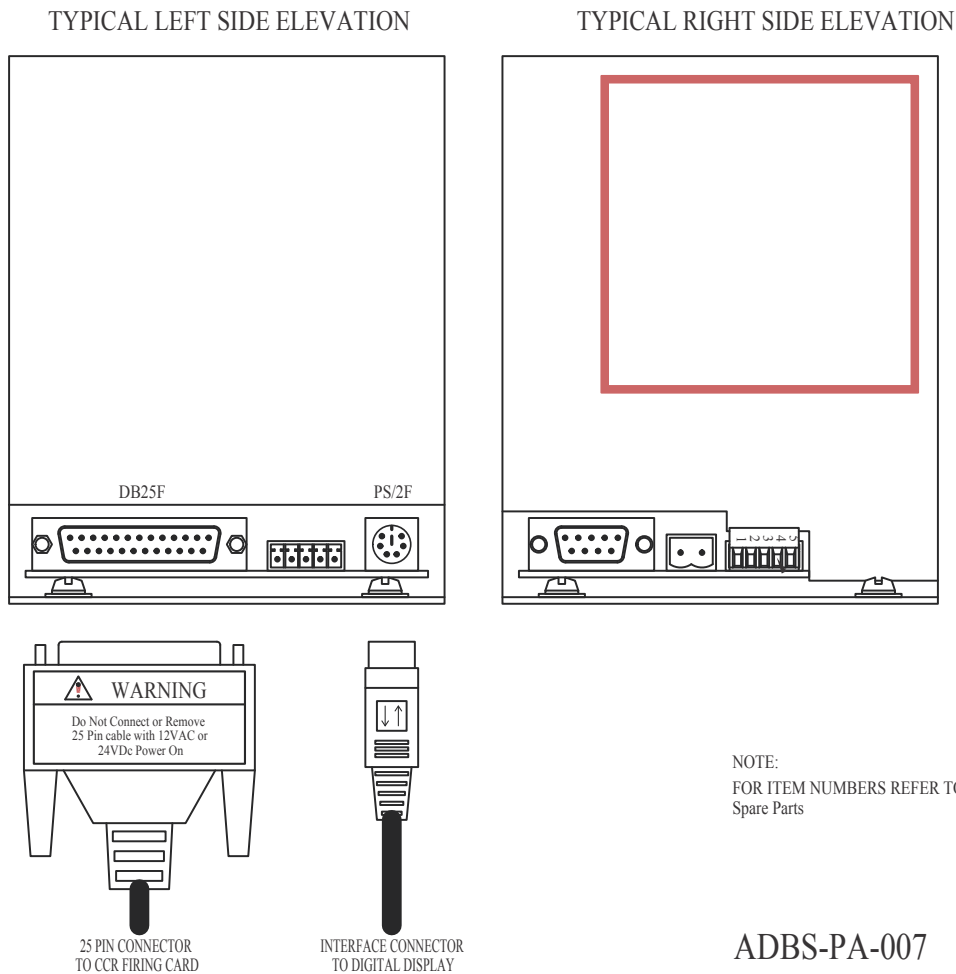

## 4.8.2 DCMU Motherboard

The DCMU Motherboard has a number of connectors located on the right and left sides of the DCMU enclosure.

- The DB9M serial connector is a programming port that allows a computer to be connected using a standard RS232 Crossover Cable. A software utility called “Configurator” provides the ability to view the status of the CCR, configure the DCMU and update the firmware.
- Terminal Block TB6 is a normally closed alarm relay that can be wired to an external monitoring system. The relay can be programmed to open on faults only, warnings and faults, or warnings, faults, and CCR not in remote.
- Terminal Block TB7 provides an input to monitor the CCR Door Interlock Switch. If the door is not closed, the DCMU will prevent operation of the regulator. 24VDC Auxiliary power supplied by the DCMU is also available on this terminal block.
- Terminal Block TB8 provides two analog inputs. For this application, the inputs are normally not used.
- The PS2/F connector is used to connect the display keypad to the DCMU.
- The DB25F connector is used to connect the DCMU to the Firing Card. A standard 25 pin serial cable is required. **Note: Do not remove the 25 pin cable while the DCMU is under power. Damage may occur to the DCMU or SCR firing card.**



### 4.8.3 DCMU Power Supply Card

The DCMU Power Supply Card accepts 12 VAC and two 24VDC backup supplies. Any one of the supplies will power up the DCMU.

- Terminal Block TB2 provides connections for a 12 VAC source. 12VAC is required in order to operate the regulator.  
**Note: A ground connection should always be made to this connector even if a 12VAC source is not used.**
- Terminal Block TB1 provides (optional) connections for two 24VDC backup supplies (18 to 30VDC). The supplies must not be isolated and commons for these supplies must be tied together. One or two supplies can be used to provide backup power for monitoring.

### 4.8.4 DCMU Input Card

The DCMU supports up to two input cards located in slots TB3 and TB4. Input Cards are available with 8 or 12 discrete inputs. Standard input range is 10 to 50V AC or DC (optional to 120V). All input signals on a card must be from a common supply (not isolated).

- For normal regulator operation, terminal Block TB3 provides terminals for connection of standard CC, B1 to B5 parallel control inputs from a control and monitoring system. In order to use these inputs, you must enable Parallel Inputs in the Config Menu. Parallel inputs can be configured for standard (6 inputs) or BCD (binary coded decimal - 3 inputs).
- Parallel inputs are not required if the control system interface is via RS485 or Ethernet communications.
- Terminal Block TB4 (optional) provides terminals for connection of current switch and remote switch monitoring signals from connected circuit selectors .

### 4.8.5 DCMU Output Card

The DCMU supports up to two output cards (slots TB4 and TB5). The Output Card has 6 mechanically latching relays with AC/DC contacts rated 1.0A at 30V or 0.5A at 125V.

- For normal regulator control, the DCMU is not provided with an output card.
- If the CCR is provided with internal circuit selector control (optional), one card is installed (TB5). Terminal Block TB5 provides terminals for connection of up to 6 parallel outputs to control 6 circuit selectors.

### 4.8.6 DCMU Communication Cards

The DCMU supports four different communication cards; RS485, Redundant RS485, Ethernet and Redundant Ethernet. Only one card can be installed in the slot next to the power supply.

- The RS485 Cards can be connected in a 2 wire or 4 wire configuration with shield. Available protocols are Modbus and Allen-Bradley DF1. Baud rate is supported up to 115,200 Baud.
- The Ethernet Cards support 10 or 100MB Ethernet networks. Available protocols are Modbus TCP and Ethernet/IP.

### 4.8.7 Operator Interface

The Operator Interface consists of a membrane keypad, Vacuum Fluorescent Display (VFD) and display interface circuit card. All functions are displayed, controlled, calibrated and adjusted using the operator interface.

- The VFD consists of a 4 line x 20 character display that operates in temperatures from -40 o C to +55 o C.
- The membrane keypad contains 11 dome pushbuttons with tactile response providing access to all display values and configuration parameters.
- Four LED indicating lights provide On and Remote status and indication of warning and fault conditions.
- The Operator Interface connects to the DCMU with a special interface cable. The DCMU end uses a standard PS/2 connector.
- Operator Interface



### 4.8.8 SCR Firing Card

The firing card is the control device and wiring interface for the analog signals to be measured. External CTs are installed and wired to the firing card.

- A 2 pin connector (J5) is the normally open (NO) contact of the control relay used to control the main contactor.
- A 6 pin connector (J9) provides connection points for the analog input signals.
- Two 2 pin connectors (J10, J11) provide the output firing signals to the SCRs.
- The DB25F connector is used to connect the Firing Card to the DCMU. A standard 25 pin serial cable is required. **Note: Do not remove the 25 pin cable while the DCMU is under power. Damage may occur to the DCMU or firing card.**

**Table 3: SCR Firing Card Terminals**

Terminals	Pin	Label
Input (J9)		
Output CT Positive	1	CT2A
Output CT Negative	2	CT2B
Input CT Positive (optional)	3	CT1A
Input CT Negative (optional)	4	CT1B
Output Voltage Line	5	V1
Output Voltage Neutral	6	V2
Output		
SCR 1 Gate (J10)	1	J10-G
SCR 1 Cathode (J10)	2	J10-K
Output		
SCR 2 Gate (J11)	1	J11-G
SCR 2 Cathode (J11)	2	J11-K
Output Relay Contact (J5)	1	K1
Output Relay Contact (J5)	2	K2

Figure 9: SCR Firing Card



### 4.8.9 Megger Power Supply Card

The megger power supply card is part of an optional hardware system that is used to measure the insulation resistance of the airfield lighting circuit to ground. The megger card plugs into the firing card, and can be supplied with a new regulator, or can be installed at a later date. Supplied with a precision, high-voltage megger resistor assembly, the system can measure the resistance of the lighting circuit from zero to 2 Giga-ohm.

- The megger system superimposes a 500 VDC signal on the field cables and measures the leakage current that returns through the ground. The resulting value is scaled in kilo-Ohms.
- The megger system can be used when the regulator is on or off.
- Fig. 15 Megger Power Supply Card

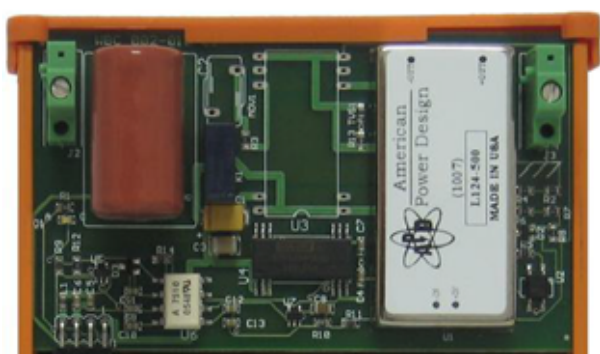

### 4.8.10 Megger Resistor Assembly

The megger resistor assembly contains a 1 Megga-ohm precision resistor mounted in an 5KV insulated housing. This is mounted inside the CCR and connects to one of the output field cable terminals.

The output CT may also be 100 to 0.1 ratio, however with 9 turns through the CT for 6.6A output and 3 turns for 20A output. A voltage signal is developed with a 110 ohm, 1% resistor connected internally across firing card terminals 1 and 2. With a 6.6A CCR at full output, the signal will be  $(6.6 \text{ A} \times 9 \text{ turns} = 59.4 \text{ A} \text{ divided by ratio of } 1,000 \text{ to } 1 = 0.0594 \times 110 \text{ Ohms} = 6.534 \text{ VAC}$ . With a 20 A CCR, the maximum output signal at 20 A will be 6.6 VAC. The slight difference between the maximum input signals is compensated with the calibration of the output current reading

### 4.8.11 Voltage Measurements

Depending on the regulator rating and connected load, the output voltage can be as high as 4,545 VAC. When the regulator is fully loaded with the airfield lighting circuit, the voltage developed on the secondary (high voltage) side of the output transformer will also develop full voltage on the 32V control winding. This winding is connected to firing card terminals 5 and 6. By measuring the voltage at the firing card, the percentage of output voltage can be calculated. Refer to Figure 16 for the actual output voltage values for each CCR rating.

For example, if the output voltage is measured as 22 VAC, and the regulator is a 30 kW, the calculation would be as follows. The measured voltage divided by the maximum voltage  $(22 \text{ divided by } 32) = 0.6875$ . Multiplying this by the maximum regulator voltage  $(4,545 \times 0.6875) = 3,125 \text{ VAC}$  on the field circuit.

The analog signals to the firing card can only be tested with the regulator in operation and with the door switch defeated. This must only be done by trained and experienced personnel familiar not only with high voltage power equipment, but with constant current regulators as well.

### 4.8.12 Current Measurements

Current transformers are required for measuring the input and output current.

The input CT most commonly used has a 100 to 0.1 ratio. One of the incoming power supply leads is passed once through the CT. A voltage signal is developed with a 100 ohm, 1% resistor connected internally. The input signal will vary based on the regulator rating, the input voltage, and the regulator loading. For input currents greater than 100A, an external 100 ohm resistor is connected in parallel with the internal resistor to reduce the input signal level.

### 4.8.13 Control Transformer

A control transformer steps down the input voltage to levels required by the regulator control circuits. 120VAC is required for the contactor coil, as well as for internal 120VAC control power. 12VAC is required by the DCMU.

### 4.8.14 Incoming Breaker and Contactor

An incoming circuit breaker (optional) provides over-current and overload protection for the regulator as well as a means of disconnecting the CCR from the incoming power source.

The contactor is used to switch the regulator on and off when commanded from either the control tower or from the local display on the front of the CCR. The 2 pin connector on the firing card provides the dry contact (relay) output signal.

The contactor also opens and disconnects the input power from the load under various trip conditions including over-current, open circuit or door interlock trip conditions.

### 4.8.15 Lightning Arrestors

Lightning arrestors are provided when specified. Output lightning arrestors are supplied at 3KV and 6KV operating voltages and are connected directly between the output field cables and ground. Input lightning arrestors connect between the incoming line terminals and ground.

**Table 4: Output Voltage Values and Lightning Arrestor Sizes**

kW Rating	Output Amps	Output Voltage	Output Lightning Arrestor
1	Class 1 6.6 A	152	3 KV
2.5		379	3 KV
4		606	3 KV
7.5		1136	3 KV
10		1515	3 KV
15		2273	3 KV
20		3030	6 KV
25		3788	6 KV
30		4545	6 KV
20		Class 2 20 A	1000
25	1250		3 KV
30	1500		3 KV

## 5.0 Operation

This section describes how to use the DCMU Operator Interface. Additional information required for modifying configuration settings or calibration is included in Calibration and Messages & Warnings.

**Figure 10: Operator Interface Display**



### 5.1 Button Operation

The button operation allows the operator to control many aspects of the CCR.

#### 5.1.1 Remote Button

The REMOTE button is used to select remote operation (ie. from the Control System), or local operation (from this keypad).

- When the REMOTE button is selected (in remote mode), the Local Control buttons will have no effect.
- A Green LED on the REMOTE button indicates when the DCMU is in Remote mode. Normally the LED should be lit, indicating that the Control Tower has control of the regulator.

#### 5.1.2 Local Control Buttons

The buttons labeled ON and LOCAL (with Up/Down arrows) are used to turn the regulator on and off and to different brightness steps.

- If the regulator is Off, pressing the ON button will turn the regulator on. If the regulator is already on, pressing the ON button will turn the regulator Off.
- If the regulator is commanded on, the green LED indicator on the ON button will be lit.
- For safety reasons, the regulator can be switched off using the ON button, regardless of whether the regulator is in Local or Remote mode
- The ON button will work even when the user is in Configuration or Calibration Mode.
- The two buttons with the Up and Down arrows and the LOCAL text will increase or decrease the brightness step when operating in Local mode.
- If the regulator is at the lowest brightness step, pushing the Down/Local button will turn the regulator off.
- If the regulator is off, pressing the Up/Local button will turn the regulator on.

#### 5.1.3 Fault and Warning Buttons

The buttons labeled FAULT and WARNING are used to scroll through and view the faults and warnings. If a fault occurs, the regulator will not be operating, If a warning occurs, the regulator will still be operating but may not be operating within the normal allowable specifications.

- If a fault occurs, the DCMU will trip and lock-out the regulator. A red LED on the FAULT button will light. Pressing the FAULT button will clear the fault (if the fault condition has been corrected) and allow the regulator to restart.
- If a warning occurs, the DCMU will display the most recent warning on the display. A yellow LED on the WARNING button will light. Pressing the WARNING button repeatedly will cycle through all present warnings. If a warning condition has been corrected, pressing the WARNING button will clear the warning.
- If a warning is displayed, it is possible to suppress the warning for 24 hours so that it is no longer visible to the maintenance and operations staff. This may be desirable if maintenance is aware of the problem but is not able to repair it today. To suppress the alarm when displayed, hold the warning button for 5 seconds. The warning LED will now flash indicating that there are suppressed warnings in the system. Suppressed warnings can be cleared from the System Menu.

### 5.1.4 Config Button

Pressing the Config button once will display the Configuration Menu. Configuration menus are discussed in Section 6. Pressing the Config key multiple times will cycle through additional menus (Diagnostics, CSS Control, and Auto Megger Control). Refer to Sections 4.4 to 4.6.

### 5.1.5 Scroll and Select Buttons

The two center keys with the Up and Down arrows are used to scroll through menu items, and to increase or decrease a calibration value.

The two center “dot” keys will have a function programmed by the display, with a text descriptor on the display directly above the key.

### 5.1.6 Default Display

In normal operation, the top line of the display shows the Brightness step and whether the CCR is operating in local (keypad) or Remote (control system) control. For a 5 step CCR, the brightness is listed as Off, B1 to B5. For a 3 step CCR, the brightness is listed as Off, B10, B30, B100. To use the Remote mode, either parallel inputs or communication must be enabled.

The following lines display operating information about the regulator. The center Up and Down arrows can be pressed to scroll to additional information. After 60 seconds of inactivity, the default screen will once again be displayed.

**Table 5: Default Display Information**

Vin	Input (line) voltage (Volts)
Iin	Input current (Amps)
Vout	Output voltage (Volts)
Iout	Output current (Amps)
KVAo	Output volt amps (KVA)
KWo	Output power (KW)
KVAi	Input volt amps (KVA)
KWi	Input power (KW)
PwrFactor	Input power factor
Lamps Out	Number of burnt out or failed lamps
Hz	Input Frequency (Hz)
Temp	DCMU Internal temperature ( ° C)
Mgr	Megger Insulation resistance (kOhms)
HwVer	DCMU hardware version number
SwVr	DCMU software (firmware) version

Note: if the input current CT is not installed or the input current is disabled, dashed lines will be displayed for Iin in place of an actual value. KVAin, KWi and PF readings will not be displayed on the screen in this case.

Figure 11: Displays - Additional Data Shown By Scrolling Down



### 5.1.7 Warning and Fault Messages

If there is a warning or fault, the top line of the display will show a message indicating the nature of the warning or fault. If there are a number of Warning or Fault messages, the Warning or Fault key can be pressed repeatedly to scroll through all the messages that are active. All of the Warning and Fault Messages are discussed in Section 5.9.

Figure 12: Display showing Door Open Trip



### 5.1.8 Diagnostic Displays

Pressing the CONFIG button multiple times will cycle through a number of displays. One of the displays is the diagnostics menu, where various diagnostics displays can be selected, including Operations, Fault Log, Warning Log, Command Log, Communications, Raw Values, Firing Parameters, Display Diagnostics, and Calibration Values.

### 5.1.9 Operations Display

The Operations screen shows the number of times the CCR has been operated as well as the elapsed time that the CCR has been operating at each of the brightness steps (B1 to B5, B10, B30, and B100)

### 5.1.10 Fault Log

The fault log screen shows the last 10 faults that were generated by the DCMU. #1 is the most recent.

### 5.1.11 Warning Log

The warning log screen shows the last 10 warnings that were generated by the DCMU. #1 is the most recent.

### 5.1.12 Command Log

The command log screen shows the last 10 commands received by the DCMU. It also indicates whether they were received from the Local keypad, from a Remote location or other source. Refer to Section 5.1 for a complete list of control source locations. #1 is the most recent command.

### 5.1.13 Communications Diagnostics (Port A / B)

Communication diagnostic screens are provided for Port A and Port B communication channels. This information can be used to troubleshoot communication problems. Diagnostic data provided includes the following:

- Status (Active, Off line)
- Rx Char, Tx Char
- Reads, Writes, Other Cmd
- Crc Errors, Timeouts, Over Runs, Rx Errors

### 5.1.14 Raw Values

The Raw Value screen shows the various analog measured values in Raw, RMS and Average values.

V in	Input (line) voltage (Volts)
I out	Output current (Amps)
V out	Output voltage (Volts)
I in	Input current (Amps)
Megger	Megger Insulation resistance (k Ohms)
Phase	Phase Angle

Figure 13: Diagnostic Display Screens

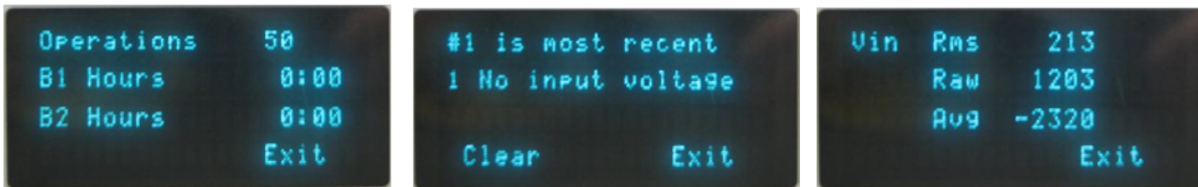

### 5.1.15 Firing Parameters

The information provided on this display may be useful when troubleshooting a particular problem. Changing configuration parameters as described in Section 5 may alter the performance. Contact Liberty for assistance.

- Period, Top Half, Bottom Half
- Synch Count, Spikes
- High Tap, Low Tap, Active Tap

### 5.1.16 Display Diagnostics

This screen shows diagnostic information on the VFD display including the following:

- Status (Online / Off line)
- Version
- Rx Errors, Tx Errors

### 5.1.17 Calibration Values

The Calibration Value screen shows the various analog zero and span values saved during calibration.

V in	Input (line) voltage
I out	Output current
V out	Output voltage
I in	Input current
Megger	Megger Insulation resistance

Figure 14: Auto Megger Control Screen

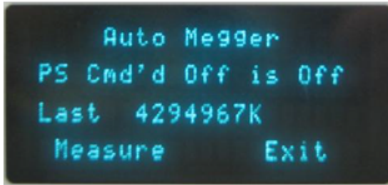

### 5.1.18 Auto Megger Control Display

Pressing the CONFIG button multiple times will cycle through a number of displays. One of the displays is the Auto Megger Control Display screen. This screen provides the ability to perform a manual megger on demand. Also displayed is the status of the 500VDC megger power supply. If automatic meggering has not been enabled, this display will not be shown.

PS	- Command Status (Cmd'd Off or On)
PS	- Actual Status (is Off / is On)
Last	- Last Megger Reading (in K ohms)

Figure 15: CSS Control Screen



### 5.1.19 CSS Control Display

Pressing the CONFIG button multiple times will cycle through a number of displays. One of the displays is the CSS Control Display screen. This screen provides the ability to manually control up to 6 circuit selector switches on demand. If circuit selector control has not been enabled, this display will not be shown. Controlling circuit selectors directly from the CCR requires an additional input and output card to be included with the DCMU. This option is only applicable if CCR control is via Ethernet or RS485 communication. The screen displays the status of each of the 6 circuit selector switches (CSS) as follows:

- Cmd - Commanded On / Off (On=Y / Off =N)
- Rem - Operating in Remote (Tower) or Local (keypad) Mode (Rem = Y / Local = N)
- Cur - Current Monitoring Feedback (Y = Current Present, N = Off)
- Err - Error (Cur = N when Cmd = Y or Cur = Y when Cmd = N)

### 5.1.20 Power Save Mode

The VFD display consumes a considerable amount of power when continuously powered up. In order to conserve energy and reduce the operating temperature of the DCMU, a power save feature has been provided.

- After a period of inactivity (configurable using the Configurator software), the display will blank out. The Fault, Warning, Remote and On LEDs will continue to operate normally.
- If all four of the LED's are off (meaning the DCMU is in local control, the CCR is off and there are no warnings or faults), the Remote LED will flash to indicate that the DCMU is still powered up, but in Power Save Mode.
- Pressing any key (except the ON key) will cause the display to become visible again without the keys having any effect. The On key when pressed will turn the CCR on or off when pressed.

## 5.2 Configuration

Pressing the Config button once will display the Configuration Menu. Pressing the Config key multiple times will cycle through additional menus and then return to the configuration menu again.



## CAUTION

Allow only qualified personnel to perform maintenance, troubleshooting, and repair tasks.

Changes must be made by qualified personnel. Making changes incorrectly may cause the DCMU or regulator to not operate correctly. There is also a risk that lamps could be damaged if settings affecting current regulation are modified.

Failure to follow these warnings will result in equipment damage.

---

The DCMU has a very powerful set of parameters that can be configured by the user. While this may help to address unique field issues, or allow the CCR to adapt to changing airport requirements, caution must be exercised when changing any setting.

## 5.2.1 Navigating the Menus

There are five main Menus that are accessible under the CONFIG menu. They are CCR CONFIG, CSS CONFIG, MONITOR CONFIG, COMMS CONFIG, and SYSTEM COMMANDS. These will be described in the following sections.

In menus, an arrow facing towards the right is used to indicate which menu item has been selected. The other items will have either an upward or downward facing arrow to indicate that other menu items can be seen by scrolling with the Up and Down keys located below the display.

The two "Dot" buttons are used for different functions depending on which menu is selected. The functions are indicated immediately above the "dot" buttons.

Pressing the Select key will either show the next menu, or select the item with the arrow beside it. Pressing the Exit key will move back to the previous display.

## 5.2.2 Config Password

The configuration menu is entered by pressing the CONFIG button on the keypad only once. Unless passwords have been disabled, the user will then be prompted for a password. This prevents unauthorized personnel from changing settings inadvertently. The factory default password is 9999. Using the Up/Down arrows enter the number and the right "dot" button to move to the next character. When the password is entered, press the Left "Dot" button to Accept.

**Figure 16:** Fig. 27 Configuration Menu - Scroll for More Options

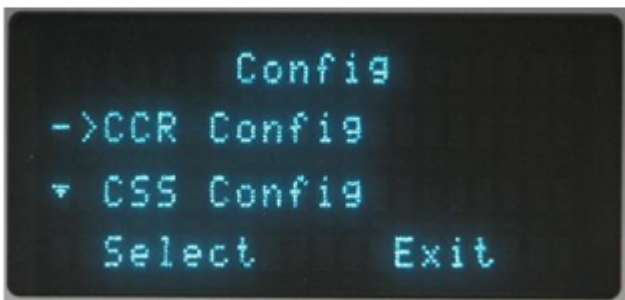

## 5.2.3 Saving Changes

Changes that have been made to Configuration or Calibration values are immediately saved to the DCMU memory. As long as power is not interrupted to the DCMU, these changes are retained.

After changes are made, when exiting back to the main display a prompt will ask whether to record the changes to permanent (EEPROM) memory. If the Yes key is pressed, then the values are recorded to the DCMU EEPROM. If the No key is pressed, the values are not stored.

**Figure 17:** Fig. 26 Enter Password Display



If power is cycled off and on to the DCMU, the last saved values will be restored from the EEPROM. As a general rule, always respond with Yes to the request to Record Changes so that the memory and EEPROM values are the same.

## 5.2.4 Explanation of CCR Critical Settings

The operation of the regulator can be fine tuned to compensate for unique field conditions that may be encountered.

CAUTION: Making changes incorrectly may cause the DCMU or regulator to not operate correctly.

## 5.2.5 CCR Types

The DCMU is capable of controlling three types of regulators; Ferroresonant (Ferro), Thyristor with 4 SCRs (SCR4) and Thyristor with 2 SCRs (SCR). The correct regulator type must be selected in order for the regulator to operate. The Spirit Series Thyristor CCR must always be set to SCR.

- If Ferroresonant is selected instead of SCR, the regulator will trip on No Current, as the DCMU is attempting to control an output that does not exist. As the SCRs must be gated on to supply output power, if they are not fired the regulator will have no output current.
- If SCR(4) is selected instead of SCR, the output current may be unstable or the regulator may trip on No Current.

## 5.2.6 Min Delay

The Min Delay will set the minimum time that the low tap SCRs will stay off after a zero crossing. This is the earliest that the low tap SCRs can turn on. If the regulator only has one pair of SCRs, then this will still apply.

## 5.2.7 Max Delay

The Max Delay will set the maximum time that the SCRs will turn on after a zero crossing. This is the latest that the 100% SCR pair can turn on. If the regulator only has one pair of SCRs, then this will still apply.

The Min Delay and Max Delay settings determine the range of control that the DCMU will have over the firing control of the SCRs. The Min Delay default value is 1.000 ms, the Max Delay default value is 7.600 ms. Under normal circumstances, these values should be changed only if a recommendation is made by Liberty Airport Systems to resolve any technical or troubleshooting issues.

Note that the SCRs can be turned on anytime in every half-cycle of the applied waveform. With a 60 Hz supply, this results in a maximum period every half-cycle of 8.300 ms (1 divided by 2 x 60).

If the Min Delay is made too small, or the Max Delay is made too large, there is the possibility that the firing sequence could jump into the next half-cycle. This will cause misfiring and a possible loss of output current regulation. If misfiring is severe, there is a possibility an SCR protection fuse will blow.

## 5.2.8 Low Tap Delay

The Low Tap Delay is used only when SCR(4) is selected.

## 5.2.9 Picket Width

Picket Width setting will adjust the time between the firing pulses to the SCRs. This setting should remain at the default value, and should only be adjusted at the request of Liberty Airport Systems technical personnel.

## 5.2.10 Damping

The Damping setting will affect the reaction time of the regulator, and is normally set between 10% to 20%. A setting too low or high may cause output current instability.

## 5.2.11 Contactor Delay

The Contactor Delay setting is used when the main contactor is turned on. This setting provides an adjustment to compensate for a contactor that has a slow closing time. Without the delay, there is a possibility of a No Current Trip, as the DCMU may not receive an output current feedback within a suitable time.

The delay action, however, does increase the amount of time required to turn on the regulator, and will also increase the over-current and open circuit trip times. If a Contactor Delay is not required, the setting should be set as low as possible, or disabled completely with a setting of 0 cycles.

There is a built-in delay that is used when the regulator is turned off. This delay will stop the SCR firing before the contactor is dropped out, increasing the contactor life. The built-in delay cannot be changed or modified.

## 5.2.12 Soft Start Feature

The built-in soft-start feature allows the output current to be gradually increased, instead of being switched on immediately to the commanded brightness step. This feature is used to increase lamp life, as well as preventing a sudden surge on the utility or generator when all CCRs are switched on simultaneously. The B1 Dwell Time setting allows the CCR to turn on to B1, and then remain at this step for an extended period of time. The Step Period defines the (soft start) rate at which the CCR ramps up through the brightness steps. For low visibility operations, this feature may be disabled to provide faster response times when a brightness change is requested.

## 5.3 CCR Config Menu

The following table describes the menus and selections that can be selected under the CCR Config Menu. Refer to the Menu Navigation Chart included in Section 11.0 for more details. For calibration details, refer to Section 7.0.

**Table 6: CCR Config Menu**

Menu	Description
Input Voltage	Select the primary input voltage to the regulator. Default = 480V.
On Threshold	Threshold at which the DCMU considers input power to be available. Default = 85%.
Off Threshold	Threshold at which the DCMU considers input power to drop out. Default = 75%.
Input Frequency	Select 50 or 60 Hz depending on the line frequency. Default = 60 Hz.
Input CT	Enable if an input CT is installed. Default = Disabled.
Ferro	Not Used for Spirit Series Thyristor CCR.
SCR (4)	Not Used for Spirit Series Thyristor CCR.
SCR	Defaults: Min= 1.0 Max= 7.6, Damp= 20%, Picket Width= 100
Number of Steps	Enter the number of steps (1,3,5,7) that the regulator is set to. Default = 5 Steps.

**Table 6: CCR Config Menu**

Maximum Current	Enter the output current rating (6.6A or 20A) of the regulator. Default = 6.6A.																												
Asymetry Trip	Enter values for Threshold and Duration. Defaults are 10% and 30 cycles.																												
Temp Adjust	Enter value to compensate at extremely low operating temperatures (below -20C). Default = 0%.																												
B1 Dwell Time	Enter the length of time (in ms) for the CCR to remain at B1 before ramping to the desired brightness step. Default = 0 ms.																												
Step Period	Enter the length of time to remain on each brightness step when ramping up in a soft start mode. Default = 0 ms.																												
B1 to B7 Current	Current set points are automatically set when # steps and max current are entered. 1 Step - 5.5A, 3 Step - 4.8A, 5.5A, 6.6A 5 Step - 2.8A, 3.4A, 4.1A, 5.2A, 6.6A 5 Step - 8.5A, 10.3A, 12.4A, 15.8A, 20.0A Each step can be manually set to a different value to accommodate unique field settings.																												
Output Power	Enter the KW Rating of the CCR. Values are 1, 2, 4, 7.5, 10, 15, 20, 25, 30, 50, 70 KW. Default = 1 KW.																												
Parallel Inputs	Enable Standard to operate CCR using separate wires for each step. Enable BCD to provide all steps with only 3 wires.  <table border="1" style="margin-left: 40px;"> <thead> <tr> <th>Step</th> <th>Input 1</th> <th>Input 2</th> <th>Input 3</th> </tr> </thead> <tbody> <tr> <td>Off</td> <td>0</td> <td>0</td> <td>0</td> </tr> <tr> <td>B1</td> <td>0</td> <td>0</td> <td>1</td> </tr> <tr> <td>B2</td> <td>0</td> <td>1</td> <td>0</td> </tr> <tr> <td>B3</td> <td>0</td> <td>1</td> <td>1</td> </tr> <tr> <td>B4</td> <td>1</td> <td>0</td> <td>0</td> </tr> <tr> <td>B5</td> <td>1</td> <td>0</td> <td>1</td> </tr> </tbody> </table>	Step	Input 1	Input 2	Input 3	Off	0	0	0	B1	0	0	1	B2	0	1	0	B3	0	1	1	B4	1	0	0	B5	1	0	1
Step	Input 1	Input 2	Input 3																										
Off	0	0	0																										
B1	0	0	1																										
B2	0	1	0																										
B3	0	1	1																										
B4	1	0	0																										
B5	1	0	1																										
Relay Feedback	An optional non-latching relay output card can provide 6 dry contact outputs for interface to a control system to indicate the actual brightness step of the CCR. Individual outputs can be provided for CC, B1 to B5, or CC, B2 to B5 and monitoring whether the CCR is in Remote (in ATC control). Default= Disabled.																												
Output Voltage Flip	Enabling this setting inverts the voltage signal with respect to the current to adjust for field installation errors. Default = Disabled.																												
Contactors Delay	Enter time to delay the contactor when commanded on. Default = 60 cycles.																												
Fault Relay	Selects the conditions under which the fault relay will open. The conditions can be a fault, warning, local mode or remote mode. More than one condition can be selected. Default = Fault.																												
Calibrate	Calibrate analog values. See Section 7.0.																												

## 5.4 Monitoring Config Menu

The following table describes the menus and selections that can be selected under the Monitoring Config Menu. For calibration details, refer to Section 5.8.

**Table 7: Monitoring Config Menu**

Menu	Description
Lamp Outage	Enable to monitor the number of burnt out lamps on the regulator. Default = disabled.
Number of Lamps	Enter the total number of lamps on the field circuit. Default = 100.
Lamp Out Warning	Enter number of lamp failures that will trigger a warning. Default = 5.
Lamp Out Alarm	Enter number of lamp failures that will trigger an alarm. Default = 10.

**Table 7: Monitoring Config Menu**

Menu	Description
VA Changes	Enable to monitor changes in Volt Amps on the regulator. Default = disabled.
VA Low Alarm	Enter percentage drop in VA that will trigger a warning. Default = 10%.
VA High Alarm	Enter percentage increase in VA that will trigger a warning. Default = 10%.
Current Monitor	Enable to monitor changes in output current on the regulator. Default = enabled.
Warning Deviation	Enter deviation in output current that will trigger a warning. Default = 0.05 A.
Alarm Deviation	Enter deviation in output current that will trigger an alarm. Default = 0.10 A.
Max Off Current	Enter the maximum value of induced current that can be present on the field circuit when the CCR is switched off, before posting an Off Current High Warning. Default = 0.10 Amps.
Input Voltage	Enable to monitor changes in input voltage on the regulator. Default = enabled.
Input Volt Low Level	Input voltage low setpoint is automatically set to 95% of the nominal input voltage. It can be manually changed as desired.
Input Volt High Level	Input voltage high set point is automatically set to 110% of the nominal input voltage. It can be manually changed as desired.
Temperature	Enable to monitor high temperature within the DCMU. Default = enabled at 60 o C
Auto Megger	Enable to monitor the field circuit insulation resistance to ground. Default = disabled.
Measure Now	Selecting this item performs a manual megger reading now.
Megger Resistor	Select the value to match the installed megger resistor. Default = 1000 k ohm.
Reading Duration	Select the desired length of time to energize the 500VDC supply. Default = 120 sec.
Auto Measure	Select the desired automatic settings. Default = Disabled.
Warning Level	Enter megger reading that will trigger a warning. Default = 500 k Ohms.
Alarm Level	Enter megger reading that will trigger an alarm. Default = 100 k Ohms.
Output Voltage	Enable to alarm if the output of the CCR is shorted. Default = enabled.
Fuse Monitor	Enable to alarm on fuse failure. Normally used on SCR CCRs. Default = disabled.
Comms 24V	Enable to monitor the 24VDC backup power supplies. Default = disabled.

## 5.5 Comms Config Menu

The DCMU can be equipped with an RS485 or Ethernet communication card, either in standard or redundant configurations. If a communication card is provided, comms must be enabled using the Comms Config Menu. Once comms are enabled, the CCR can be controlled and monitored directly from the Airfield Lighting Control and Monitoring System (ALCMS) over the network. Various protocols are available. Contact sales support for information on how to interface the CCR or DCMU with your control system. The following table describes the menus and selections that can be selected under the Comms Config Menu.

**Table 8: Comms Config Menu**

Menu	Description
Comms Enable	Enable comms to communicate to the control system using RS485 or Ethernet networks. Default = disabled.
Address	For RS485 Networks set this to a unique address from 1 to 254. For Ethernet networks set this to Address 1. Default = 1.
Remote Switch	Enable to allow a manual override switch to take priority over the communication links. The switch is wired to the parallel inputs (parallel inputs must also be enabled). Default = disabled.
Port A (B) Protocol	Select Modbus, DF1 half duplex, or DF1 full duplex. For Ethernet networks, select Modbus.
Port A (B) Baud Rate	Select Off to disable port. Select desired baud rate as required. Default = 19,200.
Port A (B) Parity	Select desired parity. Default = even.

**Table 8: Comms Config Menu**

Menu	Description
Port A (B) IP Address	Enter the Ethernet IP Address for each Port. Default for Port A = 192.168.100.150. Default for Port B = 192.168.200.150. <i>Note: Ensure that each DCMU has a unique IP Address on the network. Duplicate IP Addresses will cause network problems.</i>
Port A (B) Subnet	Select the desired subnet from the list. Default = 255.255.255.0
Heartbeat	Enabling heartbeat creates a handshake between the DCMU and the control system. A changing value is written to a register and monitored by the DCMU. If the value in the register stops changing, the DCMU goes into failsafe mode. If heartbeat is disabled, the DCMU must continuously receive the brightness command from the control system to keep the CCR out of failsafe. Default = Enabled.
Failsafe Setting	If comms are lost, the DCMU goes into failsafe. Default = Last State. Last State - CCR remains at the last commanded brightness step Parallel Inputs - CCR turns on to a step defined by a remote switch wired to the parallel inputs Defined Step - CCR turns on to a pre-defined step as defined in this menu Step if Off - CCR remains at the last commanded brightness step if the CCR is currently on. If the CCR is currently off, it turns on to a pre-defined brightness step.
Failsafe Delay	If comms are lost, the DCMU waits for a period of time (as defined here) before going into failsafe mode. Default = 30 sec.

## 5.6 CSS Config Menu

The Circuit Selector Switch, or CSS menu allows up to six L-847 type circuit selectors to be controlled and monitored directly from the CCR. The DCMU requires an optional input card and an optional latching relay output card to be installed into the DCMU housing. This option is often used with a Circuit Selector Switch cell that is installed as part of a switchgear lineup.

With the use of a CSS, there is often a Current Switch (CS) installed to detect current flow. The DCMU processor, when any circuit is turned On, will look for a 24 VDC signal to an input card from the CS for that circuit within a time period of approximately 2 seconds. If the input feedback is not received, a Warning message is given for that circuit. The chart below shows the various menus and parameters that can be selected under the CSS Config Menu.

**Table 9: CSS Config Menu**

Menu	Description
CSS Enable	Enable circuit selector operation from the Auxiliary Keypad. Default = disabled.
Number of CSS	Enter number of circuits to be controlled (maximum of 6 for CCR applications). Default = None.
CSS Fault Monitor	Enable monitoring of the output current of each circuit using a current switch. Default = disabled.
Failsafe Setting	If comms are lost, the DCMU goes into failsafe. Default = Last State.
	Last State - CSS remains at it's last commanded state
	Off - CSS turns off
	On - CSS turns on
	Each circuit can be configured independently.

## 5.7 System Commands Menu

The System Commands menu provides a number of options to save and restore Configuration and Calibration values. These can be Factory Settings, or Configuration and Calibration values that were saved when the regulator was manufactured and tested, or commissioned into service.



## CAUTION

Changes must be made by qualified personnel. Restoring Factory Defaults or Restoring settings that aren't correct can cause the DCMU or regulator to not operate correctly. There is also a risk that lamps could be damaged if settings affecting current regulation are modified.

Failure to follow these warnings may result in serious injury or equipment damage.

The table below shows the various menus and parameters that can be selected under the System Commands Menu.

**Table 10: System Commands Menu**

Menu	Description
Second Language	Select either English or a second language if installed with the firmware. Currently available second languages are French and Spanish.
Factory - Restore Config	Restores factory default configuration settings immediately with no other prompts to acknowledge. Under normal circumstances, this should not be done unless at the request of Liberty Airport Systems. If there is not a Known Good Configuration saved, the configuration will have to be redone. Make sure you record the previous configuration settings before restoring factory defaults.
Factory - Restore Calib.	Restores factory default calibration settings immediately with no other prompts to acknowledge. Under normal circumstances, this should not be done unless at the request of Liberty Airport Systems.  If there is not a Known Good Calibration saved, the calibration will have to be redone.  When leaving the Configuration menu, as explained in section <a href="#">"Saving Changes"</a> , a request will be made to Record Changes. If the Yes key is pressed, the Factory Configuration or Calibration values become permanent. If the No key is pressed, power to the DCMU can be cycled or the Reset command can be used to restore the previous settings.
Known Good Settings - Restore Config	Selecting "Known Good Settings Restore Config" is only possible if a saved file exists. If one has never been saved using the "Save Config" function, then a message will be displayed stating "Known Good Config Not Found"  If there is a valid configuration selecting the "Restore Config" will immediately restore those values without any further prompts.
Known Good Settings - Save Config	Selecting "Known Good Settings Save Config" will store all of the configuration data values to the EEPROM. When complete, a message will be displayed stating "Known Good Config Saved".
Known Good Settings - Restore Calib.	Selecting "Known Good Settings Restore Calibration" is only possible if a saved file exists. If one has never been saved using the "Save Calib." function, then a message will be displayed stating "Known Good Calib Not Found".  If there is a valid calibration, selecting the "Restore Calib" will immediately restore those values without any further prompts.
Known Good Settings - Save Calib	Selecting "Known Good Settings Save Calib." will store all of the calibration data values to the EEPROM. When complete, a message will be displayed stating "Known Good Calib. Saved".
Clear Supp Warn	If warnings have been suppressed by holding down the WARNING button while a warning is displayed on the display, they can be cleared by selecting this menu choice.
Clear Counters	Operations and Elapsed timers for each of the brightness steps can be reset to zero by selecting this menu choice.
Reset	Selecting Reset from the System Commands menu will cause the processor of the DCMU to reset. The System Command for Reset should only be done at the request of Liberty Airport Systems. Once the Reset is complete, the display will return to the default display screen.
Boot Block	Selecting Boot Block will stop the control program from running. Normally, this menu item should only be selected if requested by Liberty Airport Systems. The Boot Block is only used before loading a new program.  Once in Boot Block, the processor will not run the control program. If this item was selected in error, remove all power to the DCMU, wait a few seconds, and then restore power. The processor will reboot and will run the control program once again.

## 5.8 Current and Voltage Calibrations

The DCMU, when used as a Digital Control Interface, must be calibrated with the specific regulator being controlled and/or monitored. Minor differences in hardware will affect the indication of the output current and other display values. If the DCMU or Firing Card of the regulator is changed or replaced, calibration should be performed before placing the regulator in service.

- It is recommended to use a resistor load bank when doing the calibrations rather than the field circuit. Incorrect output current calibration could cause damage to the lamps in the field.

To perform a complete calibration, it is recommended to follow the steps in the sequence outlined below.

### 5.8.1 Zeros

Calibrating the Zeros is performed to properly sequence the control of the regulator with the input supply waveform. The input supply waveform is measured and detected with the 12 VAC supply on terminals 1 and 2 of TB2 on the DCMU.

- Before pressing the Zeros key, ensure that the regulator is turned off. Select the Zeros calibrate by pressing the Select key for that function. Once selected, an automated sequence is started.
- The two separate numbers will change either up or down while the calibration routine is being done. The numbers represent the positive and negative halves of the input supply waveform. If the Quit key is pressed, the calibration routine will be stopped. A message will be displayed when the calibration is completed.

If the regulator has already been in service and the Zeros Calibration is performed, the stored values for the Lamp Outage Calibration and VA Changes may be affected. If a Zeros Calibration must be done, and Lamp Outage or VA Changes Monitoring is being used, the Lamp Outage Adjust function can be performed.

If all lamps are known to be good, set the Adjust value for 0 lamps out. This will correct the Lamp Outage and VA Changes calibrations without having to perform the full calibration again.

### 5.8.2 Output Current

This section is used to calibrate the output current display reading. This must be done with a True RMS Multimeter and a current probe known to have a low percentage of error. If the proper test equipment is not available, the calibration can be done by measuring the current as a voltage on firing card terminals 1 and 2. Refer to Section 3.6 for further details on the voltage signal levels.

- The regulator output current can be calibrated at any step, but for improved accuracy should be done at the highest step.
- Operate the regulator in Local mode to the highest brightness step. Measure the actual output current using a true RMS meter and accurate current probe.
- Select Calibrate - Output Current from the Config Menu. The display will have a message "Adjust Value" shown with the output current reading below it. Use the Up and Down arrows to adjust the reading to the measured value. If the actual output current, for example, was measured as 6.40 amps, adjust the value to 6.40.
- When the Accept key is pressed, the output current display is automatically adjusted to compensate for the difference. Confirm that the measured value is now the same as the displayed value. Press the Quit key to leave the screen.
- Unlike Configuration values, Calibration values are automatically stored in the processor EEPROM memory.

### 5.8.3 Output Voltage

This section is used to calibrate the output voltage in much the same way as with the output current. The regulator should be loaded as much as possible to improve the accuracy. Since the output voltage may exceed the rating of a standard meter, the calibration can be done by reading the output of the potential transformer (PT) that is connected to firing card terminals 5 and 6. Refer to Section 3.6 for further details on calculating the actual voltage using the PT ratio.

- Operate the regulator in local mode to the highest brightness step. Measure the output voltage at terminals 5 & 6 on the firing card and multiply by the PT ratio.
- Select Calibrate - Output Voltage from the Config Menu. The display will have a message "Adjust Value" shown with the output voltage reading below it. Use the Up and Down arrows to adjust the reading to the measured / calculated value.
- When the Accept key is pressed, the output voltage display is automatically adjusted to compensate for the difference. Confirm that the measured value is now the same as the displayed value. Press the Quit key to leave the screen.

## 5.8.4 Input Current

This section is used to calibrate the input current in much the same way as with the output current. The regulator should be loaded as much as possible to improve the accuracy.

- Operate the regulator in Local mode to the highest brightness step. Measure the input current using a suitable current probe.
- Select Calibrate - Input Current from the Config Menu. The display will have a message "Adjust Value" shown with the input current reading below it. Use the Up and Down arrows to adjust the reading to the measured value.
- When the Accept key is pressed, the input current display is automatically adjusted to compensate for the difference. Confirm that the measured value is now the same as the displayed value. Press the Quit key to leave the screen.

## 5.8.5 Input Voltage

This section is used to calibrate the input voltage. The input voltage can be calibrated at any time, whether the regulator is in operation or not.

- Measure the input voltage using a suitable meter.
- Select Calibrate - Input Voltage from the Config Menu. The display will have a message "Adjust Value" shown with the input voltage reading below it. Use the Up and Down arrows to adjust the reading to the measured value.
- When the Accept key is pressed, the input voltage display is automatically adjusted to compensate for the difference. Confirm that the measured value is now the same as the displayed value. Press the Quit key to leave the screen.

## 5.8.6 Output Voltage Span

In order for the regulator to operate without tripping on over-voltage, the output voltage must either be calibrated or a value entered for the output voltage span. If the output voltage is calibrated properly as shown in 7.1.3, the Output Voltage Span Calibration is not required.

In the case, where the Output Voltage cannot be calibrated (no meter available), the Output Voltage Span adjustment can be made in order to get the CCR operational.

- Select Calibrate - Output Voltage Span from the Config Menu. The display will have a message "Adjust Value" shown with the output voltage span reading below it. Use the Up and Down arrows to adjust the reading to either the correct calculated value or an approximate value until the output voltage can be calibrated.
- When the Accept key is pressed, the output voltage span display is automatically adjusted to the entered value. Press the Quit key to leave the screen.

## 5.8.7 Lamp Outage & VA Calibration

Lamp Outage is a means of calculating the number of lamps that have failed on an airfield lighting circuit. When the secondary side of an isolation transformer is closed, with either a shorting plug or a good lamp, the circuit is essentially resistive. When the secondary is open, usually because of a failed lamp, the circuit becomes inductive. The inductive change is measurable, and can be used to determine how many lamps have failed.

The accuracy of the lamp outage readings will be optimized if all isolation transformers on the airfield lighting circuit are of the same manufacturer, type and rating. Sign loads, ballasts and power adapters will reduce the accuracy of the readings, but still may provide an indication of a problem.

- Before performing the lamp outage calibration, ensure that all of the lamps on the circuit are known to be good and functioning correctly. Ensure that the regulator is properly connected to the airfield lighting circuit.
- Enable lamp outage monitoring and set the configuration parameters as detailed in Section 6.5.
- Select Calibrate (LO & VA) to start an automatic calibration routine. The routine will operate the regulator at each brightness step in sequence to record the current and voltage relationships. This information is used to develop a baseline reading for indication of the number of failed lamps. The same routine is used for Lamp Outage (LO) and for the Volt Amp (VA) alarms.
- A message will be displayed when the calibration is complete. If it is necessary to stop the calibration for any reason, simply press the On key to turn the regulator Off. When this is done, the display will show an Abort message and the Exit key will appear.
- To verify calibration, remove a selected number of lamps from the field circuit, and then energize the regulator. After a short time, the number of open lamps that have failed will be displayed.

## 5.8.8 Lamp Outage Adjustment

If the lamp outage indication on the display agrees with the actual number of failed lamps, the calibration is complete. If there is a difference between the two values, use the following Adjust function to fine tune the calibration.

- Select the Adjust function from the lamp outage menu.
- The display will have a message “Adjust Value” shown with the number of lamps failed below it. Use the Up and Down arrows to adjust the reading to match the actual number failed in the field.
- When the Accept key is pressed, an automatic calibration routine will begin. When finished, confirm that the measured value is now the same as the displayed value. Press the Quit key to leave the screen.

## 5.8.9 Lamp Outage Optimization

The DCMU when calibrated for Lamp Outage or VA Changes will store a number of data values. Initially, the DCMU stores the VA and base phase information for each brightness step, assuming that all lamps were good.

Once the calibration is complete, either then or at a later date, the Adjust function can be used to again calibrate for a known number of failed lamps. A total of three separate Adjust data values can be stored in the processor memory to optimize the accuracy of the Lamps Out Monitor function. For example, for any given circuit, the Adjust function could be performed for a total of 4, 8 and 16 lamps out. Alternately, the Adjust function could be performed at any time after the initial calibration as lamps on the circuit fail.

If the status of the number of lamps used to do an Adjust calibration is not known, all data values can be reset by performing the Calibration once again with all lamps known to be good.

Performing a Calibrate Zeros from the Calibration menu may affect the accuracy of the Lamp Outage function. Changing a firing card may also have the same affect.

Performing a Lamp Outage Adjust with the number of lamps set to zero, if all lamps on the circuit are known to be good, will adjust the calibration without losing the Adjust function stored data values.

## 5.8.10 Calibration from the VA Changes Menu

If lamp outage is not required, the VA Calibration procedure can also be run from the VA Changes menu. This is the same routine as in the Lamp Outage menu, but does not give the option to perform the lamp outage adjustment.

## 5.8.11 Automatic Megger Calibration

The Automatic Megger system consists of a 500 VDC, 1W power supply and precision resistor connected between one side of the regulator output and earth ground. The megger measures the insulation resistance to ground over a range from zero to 2Gohm. The DC signal that is injected into the airfield lighting circuit is transparent to the AC power that energizes the lights. As a result, the megger system can be used with the regulator turned on or off.

## 5.8.12 Calibrate for an Open

- Enable automatic megger and set the configuration parameters as detailed in “CCR Cong Menu” on page 31.
- Ensure the regulator is switched off. Disconnect the field circuit from the regulator output terminals leaving the output of the regulator open circuited. Defeat the door interlock. Place the DCMU into Local mode using the REMOTE button on the keypad.
- Select “Calibrate Open” from the Auto Megger menu. An automatic calibration routine will begin. The number shown while the system is calibrating is the raw value (approximately 31,000) from the megger circuit board. If the Quit key is pressed, the number indication will change to “Aborted”. A message will be displayed when the calibration is done.

## 5.8.13 Calibrate for a Short

- Ensure regulator is switched off, interlock is defeated and keypad is in Local mode (as described above). Connect a jumper from one side of the regulator output terminal (the one that has the megger lead attached) directly to ground.
- Select “Calibrate Short” from the Auto Megger menu. An automatic calibration routine will begin. The number shown while the system is calibrating is the raw value (approximately 8,000) from the megger circuit board. If the Quit key is pressed, the number indication will change to “Aborted”. A message will be displayed when the calibration is done. Remove jumper and reconnect the field cable. Verify the megger reading on an actual field circuit by selecting “Measure Now” from the Auto Megger Menu.

## 5.8.14 Calibration Values

The calibration values can be set as a Known Good Calibration Settings using the System Commands. Refer to Section 6.7 for further details.

If the calibration for the regulator is inadvertently changed, the Known Good Calibration Settings can be readily restored.

## 5.9 Messages, Warnings & Faults

Under normal operation, the top line of the display on the Operator Interface will change to announce a number of text messages. The Warning button Amber LED or the Fault button Red LED will also be energized if there is a Warning or Fault.

### 5.9.1 Brightness Step & Command Source

In normal operation, the top line of the display shows whether the CCR is off or on, and what brightness step it is currently operating at. For a 5 step CCR, the brightness is listed as Off, B1 to B5. For a 3 step CCR, the brightness is listed as Off, B10, B30, and B100. The top line of the display will also show the source of the command. A complete list of command sources are as follows.

**Table 11: Regulator Control Sources**

Source	Description
Local	"Local" Control is from the DCMU keypad.
LastSte	"Last State" may appear after a power failure, and before a communication network becomes active again.
Paralln	"Parallel Input" indicates that the CCR is being controlled with parallel voltage signals to the DCMU input circuit card.
RSwitch	"Remote Switch" is a special configuration that is used to manually control a regulator from an auxiliary switch that will override the command from a communication network.
FSSwtch	"Fail Safe Switch" indicates the CCR is in failsafe at a brightness defined by a control switch connected to the parallel input card.
ComCh A ComCh B	"Communication Channel" indicates which network the command has been accepted from, and is displayed in the command log.
FailSfe	"Fail Safe" indicates that the regulator is operating in failsafe mode due to a loss of communications on Channels A and B.
Calibr	"Calibrate" may be seen at the end of an automated calibration routine such as Lamp Outage or VA, and can appear on the command log.
Remote	"Remote" indicates that control is from communication channels A or B.
PC Cntr	"PC Control" indicates that a computer connected to the serial port of the DCMU is controlling the regulator. This will not be seen in PC monitor mode.

### 5.9.2 Actual vs Commanded Brightness

The actual brightness step of the regulator is determined by the actual output current, not by the commanded step. If the actual and commanded brightness current levels agree, the display will remain at the normal default.

If there is a difference between the actual and the commanded brightness the top line will indicate both the commanded and actual brightness steps. A difference between the actual and commanded brightness can occur for a number of reasons.

- Output current needs to be calibrated.
- Hardware failure.
- The regulator is overloaded, and cannot supply the requested output current.
- The settings for Min Delay and Max Delay for control of the regulator are limiting the full output of the regulator.
- Actual brightness is different than commanded



### 5.9.3 Warning Messages

A number of possible warning messages can be displayed. When any warning is received, the Amber LED of the Warning key will be turned on.

Note that more than one warning message can exist at a time. eg. Door Open and Low Input Voltage. By pressing the Warning key repeatedly the messages will scroll on the top line of the display one after another.

Warning messages are self-canceling. Once the condition that caused the warning is corrected, the display will return to the normal default and the Amber LED will turn off.

### 5.9.4 Monitoring System Warnings

The following warnings indicate there may be a problem with the regulator, incoming supply or field circuit.

**Table 12: Monitoring System Warnings**

Source	Description
Door Open	The connection for the door switch on terminals 1 and 2 of TB7 are open. If the regulator was in operation, it will be turned off, and if already off will not turn on.
Low Input Voltage	The Input Voltage Monitor has been enabled, and the input voltage is below the low level warning threshold.
High Input Voltage	The Input Voltage Monitor has been enabled and the input voltage is above the high level warning threshold.
No Input Voltage	No input voltage is detected at the 12 VAC input on TB2 of the power supply card. Normal cause is the main breaker feeding the CCR has been switched off. This message can only be displayed if the DCMU has an external 24VDC power source on TB1 of the the power supply.
Tolerance Warning	The output current is out of specifications and the current monitor warning threshold has been exceeded.
Tolerance Alarm	The output current is out of specifications and the current monitor alarm threshold has been exceeded.
Wrong Brightness	Actual output current does not match the output current range for the brightness step selected. Once the message is acknowledged by pressing the Warning button, the display will show the Commanded and Actual brightness settings.
Off Current High	Indicates that the output current is greater than 100 mA when the CCR is commanded off. This normally indicates that the output current needs to be calibrated.
VA Low	The VA changes low alarm has been exceeded indicating a field circuit problem.
VA High	The VA Changes high alarm has been exceeded indicating a field circuit problem.
Output Shorted	If the CCR is providing current but the output voltage is near zero, the Output Shorted message is displayed. This is intended to detect whether a safety cutout has been left in the shorted position, preventing the airfield circuit from being energized after the regulator is turned on.
Lamp Warning	The number of failed lamps in the field has exceeded the lamp outage warning threshold.
Lamp Alarm	The number of failed lamps in the field has exceeded the lamp outage alarm threshold.

**Table 12: Monitoring System Warnings**

Source	Description
Megger Warning	The measured insulation resistance of the field circuit to ground has dropped below the Megger warning level.
Megger Alarm	The measured insulation resistance of the field circuit to ground has dropped below the Megger alarm level.
CCR Not Remote	The on/off brightness switch located on the CCR door is not in the Remote position.

## 5.9.5 Communication Warnings

The following warnings indicate there may be a communication problem.

**Table 13: Communication Warnings**

Source	Description
No Comms Ch A	This message is displayed if Port A has been configured for communications and the regulator is in Remote, but there is no activity on Channel A.
No Comms Ch B	This message is displayed if Port B has been configured for communications and the regulator is in Remote, but there is no activity on Channel B.
Mismatch - Failsafe	This message will only occur if two communication channels have been configured, and each is sending a different brightness step command. If this occurs, the regulator, if still in Remote, will revert to the Failsafe mode.
Comm Loss - Failsafe	While operating in Remote control, communication through both networks has been lost. The DCMU responds by activating the Failsafe mode.
Comms 24V Missing	If monitoring of the 24VDC backup power is enabled, 24VDC must be present on at least one of the sets of TB1 terminals. If no 24 VDC supplies are connected or they have failed, the message will be displayed.
Local Comms Mode	The Local Comms Mode message is shown when a computer is connected to the 9 pin serial port of the DCMU and a configuration software program is running.

## 5.9.6 Circuit Selector Warnings

The following warnings are only applicable if the control and monitoring of circuit selector option has been provided. These warnings indicate there may be a problem with a circuit selector or circuit selector DCMU hardware.

**Table 14: Circuit Selector Warnings**

Source	Description
CSS Input Card Fault	The DCMU input card for CSS control (input card 2) is missing or has failed a power on self-test. This message is possible only if the CSS configuration has been Enabled.
CSS 123456 Error	A Circuit Selector Switch Error message for any of the configured channels from 1 to 6 will be seen if the OK input for that channel is absent. Only the channel numbers that actually have an error will display. For example, if only channel 2 is in error, the message will be CSS 2 Error.
CSS 123456 No Current	Indicates that a CSS has been commanded on, but the current switch is not showing any current.
CSS 123456 Current	Indicates that a current switch is showing current, although the CSS has not been commanded on.

## 5.9.7 Hardware Warnings

The following warnings indicate there may be a problem with the DCMU hardware.

**Table 15: Hardware Warnings**

Source	Description
High Temperature	The internal temperature inside the DCMU has exceeded the temperature high temp threshold.
Firing Card Warning	A problem has been detected with the firing card circuit board or with the measured signals.
Megger Fault	A problem has been detected with the megger circuit board or with the measured signal.
Input Card Error	This message is displayed if the input card is absent, or fails the power on self-test.
Output Card Fault	This message is displayed if the output card is absent, or fails the power on self-test.
Unknown Warning	Indicates that a warning code has been generated that does not have a corresponding text message. Under normal circumstances, this Warning will not be seen.

**Figure 18: Typical Warning Message - No Input Voltage**



### 5.9.8 Fault Messages Overview

A fault will cause the contactor of the regulator to drop out if the regulator was in operation. The Red LED on the Fault button will also be energized. Faults are retentive; they will remain displayed until the regulator is turned off or the Fault key is pressed to acknowledge the Fault.

If the fault no longer exists, when the Fault button is pressed to acknowledge the alarm, the regulator will resume operation. If the fault has not been cleared, the message for the failure will return, and the regulator will be turned off once again.

Note that a fault will only be triggered if the regulator was in operation. Pressing the Fault button to acknowledge the message will immediately turn the regulator on once again. If this is not the control action that is desired, press the ON button to remove the On command.

**Figure 19: Typical Fault Message - Door Open Trip**



### 5.9.9 Fault Messages

The following faults will cause the regulator to trip and lock out:

**Table 16: Faults**

Source	Description
No Input Voltage	No input voltage is detected at the 12 VAC input on TB2 of the power supply card. Normal cause is the main breaker feeding the CCR has tripped. This message can only be displayed if the DCMU has an external 24VDC power source on TB1 of the power supply.
Over Current	Under normal circumstances, the regulator will maintain the output current within 1% accuracy. Per FAA specifications, if the current increases to greater than 5% of maximum for 5 seconds, or greater than 25% for 1 second, the regulator will trip on over-current.  An over-current condition can occur if circuit selector switches are used. When a CSS is turned off, the voltage developed on the field circuit, now with a lower resistance, can cause a brief rise in current. An over-current condition can also be caused by a hardware or wiring failure in the regulator.
Open Circuit	If the output current is less than 1A, yet there is sufficient output voltage, the regulator will trip. This is normally the sign of an open circuit in the airfield lighting series circuit.
Over Voltage	If the output voltage remains 15% higher than the nominal output voltage (output KW divided by output amps) for more than 3 seconds, the regulator will trip. This is normally the sign of a very poor field circuit that is not completely an open circuit (eg. current is burning through the ground or arcing across a connector).
No Current	If the output current is less than 1A for approximately 3 seconds and the output voltage is low, the regulator will trip. This is normally the sign of a CCR problem (blown fuse, no firing signal).
Door Open Trip	Opening the door of the regulator will cause the DCMU to trip the regulator and display the fault message.
Current Asymmetry	Current Asymmetry is a difference between the RMS area of the positive and negative halves of the output waveform. A significant difference between the two will cause heating and eventual failure of the main power transformer output winding.  When the Current threshold is exceeded for the set duration, the regulator will be tripped Off and the Fault will be displayed.

**Table 16: Faults**

Source	Description
Time Asymmetry	<p>The time asymmetry fault addresses the situation where the output waveform is not symmetrical. In this case, the Current Asymmetry trip will tend to average out the RMS current signal. With a waveform that is distorted, there will be a difference in the durations, or the times between the positive and negative halves of the output.</p> <p>The threshold and duration settings are identical to those for the Current Asymmetry. When the threshold is exceeded for the set duration, the regulator will be tripped off and the fault will be displayed.</p> <p>Asymmetry can be caused by a lack of calibration, by noise on the input supply or by a component failure.</p>
Unknown Fault	<p>Indicates a fault code has been generated that does not have a corresponding text message. Under normal circumstances, this Fault will not be seen.</p>



## 6.0 Maintenance

Maintenance of this equipment must be performed by personnel who are fully trained, qualified and experienced with high voltage equipment and safety and lockout procedures. Refer to Safety Hazards at the beginning of this manual before working on this equipment.

The regulator is designed for safe and reliable operation, and does not require any special maintenance. Preventative maintenance on this equipment should be performed every six months along with maintenance on other airfield electrical equipment.

- Check that all power connections are tight, re-torque if necessary. Check for signs of insulation burning or discoloring.
- Check that all control connections are tight. Check for signs of insulation discoloring.
- Visually inspect the various components for signs of mechanical damage.
- Make sure that all components are clean and free of dust or dirt. Clean as required.
- For outdoor applications, inspect the door gasket seal and verify that there are no signs of corrosion.

## 6.1 Testing & Verification

All testing of the regulator must be done by trained and qualified personnel.

### 6.1.1 Testing

- Ensure that the CCR is turned off and is locked out. Verify that all wiring to the regulator and to the DCMU is secure and installed correctly per the drawings provided.
- Make sure 12VAC and 24VDC power connectors TB1 and TB2 to the DCMU are disconnected before proceeding.
- If you are testing a CCR with the output shorted, the CCR should not be operated above 4.8A (B10 or B3)
- Energize the regulator and verify that 12 - 14VAC is present on connector TB2.
- If a 24VDC backup power supply is provided, verify that 24 to 28VDC is present on connector TB1.
- Plug in connectors TB1 and TB2 and verify that the DCMU powers up and the corresponding LEDs light up on the front of the DCMU.
- Press the REMOTE button on the keypad until the green LED is off, indicating that the regulator is in local control mode (from the keypad).
- Using the ON and Up/Down Local buttons, verify that the regulator turns on and regulates at all brightness levels.
- Using an accurate true RMS meter and current probe, verify calibration settings are accurate. Recalibrate if necessary. Note: factory calibration was done with instruments with better than 1% accuracy. Before making minor adjustments, verify your meter and current probe accuracy.
- Test all warnings and faults listed in Section 5 and verify that they indicate on the display correctly.
- Make sure the control system is connected as required using parallel, RS485 or Ethernet cables per drawings. Press the REMOTE button on the keypad until the green LED is on, indicating that the regulator is in remote control mode. Test operation from the control system and verify that all warnings and faults are displayed correctly.

Test communication redundancy if enabled, and ensure that full operation continues when only one network is connected. Repeat for the other network.

## 6.2 Troubleshooting

Troubleshooting guides are intended for use by qualified personnel who have experience with the type of equipment being worked on. Constant Current Regulators and airfield lighting circuits can operate at voltages up to 5 kV, and should always be considered as high voltage circuits.

Proper safety and lockout procedures should always be used when working on this or any other type of electrical equipment.

The guide progresses from the more obvious and basic faults to specific component tests. It is difficult, if not impossible to detail each and every possible problem that could occur with a CCR or related components. For many tests, a spare part that is known to be good may be required.

**Table 17: Troubleshooting Guide**

Fault	Reason	Check
<ul style="list-style-type: none"> <li>▪ Regulator will not turn on, display is blank.</li> <li>▪ Message is displayed, No Input Voltage.</li> </ul>	<ul style="list-style-type: none"> <li>▪ Main Supply Voltage Missing.</li> <li>▪ Control Fuse Blown.</li> <li>▪ Faulty wiring connection to power supply card TB2.</li> <li>▪ Faulty power supply card.</li> <li>▪ Faulty DCMU.</li> </ul>	<ul style="list-style-type: none"> <li>▪ Check that supply power to the regulator is connected and turned On.</li> <li>▪ If there is a main breaker in the regulator, check that it is closed and not tripped.</li> <li>▪ If the display is not lit, check the DCMU. If the DCMU has power, check the cable to the display.</li> <li>▪ If the DCMU does not have power, check any control fuses installed on the 12 VAC connection to the DCMU.</li> <li>▪ Remove the 3-pin plug from TB2 of the power supply card. Measure for 12 VAC on terminals 1 and 2.</li> <li>▪ If the DCMU is receiving power, but no LEDs are on, the DCMU or power supply card may have failed.</li> <li>▪ If 24 VDC is available, make a connection on terminals 3 (24 VDC) and 4 (COM) of TB7. This will power the DCMU directly without a power supply card. If the system becomes energized, the power supply card is faulty. Note that without the 12 VAC signal to the power supply card the regulator will not turn on.</li> </ul>
<p>Display is blank, regulator does function.</p>	<ul style="list-style-type: none"> <li>▪ Poor connection between DCMU and display panel.</li> </ul>	<ul style="list-style-type: none"> <li>▪ If the display is blank, but the regulator still functions properly in Local or Remote, there may be a poor connection between the DCMU and the display panel. Unplug the PS2 connector on the bottom left side of the DCMU, and then insert it once again. If the display works again, the problem was a loose connection.</li> </ul>
<p>Message is displayed, Open Circuit</p>	<ul style="list-style-type: none"> <li>▪ Field circuit is open.</li> </ul>	<ul style="list-style-type: none"> <li>▪ Check that the field circuit is closed. If the regulator is equipped with an S1 cutout, set the cutout to the shorting position and try again. If the regulator operates in short circuit, the problem is with the field circuit.</li> </ul>
<p>Message is displayed, Over Voltage</p>	<ul style="list-style-type: none"> <li>▪ Field circuit is nearly open (arcing fault)</li> </ul>	<ul style="list-style-type: none"> <li>▪ Check that the field circuit is closed. If the regulator is equipped with an S1 cutout, set the cutout to the shorting position and try again. If the regulator operates in short circuit, the problem is with the field circuit.</li> </ul>
<p>Message is displayed, No Current.</p>	<ul style="list-style-type: none"> <li>▪ CCR Firing Card or relay may be faulty.</li> <li>▪ Contactor coil may have failed.</li> <li>▪ DCMU may be faulty.</li> <li>▪ Output CT is shorted.</li> <li>▪ Contactor Delay setting too low.</li> </ul>	<ul style="list-style-type: none"> <li>▪ Check that terminal K2 is receiving 120VAC when the firing card relay is on. If not, replace the Firing Card.</li> <li>▪ If Firing Card is OK, check the coil of the contactor.</li> <li>▪ If contactor coil is OK, and a spare DCMU is available change the DCMU.</li> <li>▪ Check the setting of the Contactor Delay. If this is too low, the regulator may trip on No Current when first turned On.</li> </ul>

**Table 17: Troubleshooting Guide**

Fault	Reason	Check
Message is displayed, Over Current	<ul style="list-style-type: none"> <li>▪ SCR Shorted.</li> <li>▪ Momentary Over-current Condition.</li> <li>▪ Calibration values incorrect.</li> </ul>	<ul style="list-style-type: none"> <li>▪ A shorted SCR can result in uncontrolled output current. Generally, this will be with only one SCR of a pair.</li> <li>▪ Check the SCR heat sink assembly. Remove the power leads from the SCR pucks. Remove the metal jumper link between power terminal 2 and 3 of the SCR puck. Check the forward and reverse resistance with a multi-meter set for ohms (do not use the diode check setting). This is between 1-2, 1-3 and 2-1 and 3-1. If there is a significant (greater than 10%) difference between the readings one of the SCRs is likely shorted, and the puck must be replaced.</li> <li>▪ If the regulator is supplying circuit selector switches, the Over Current condition may have been due to a momentary over-current condition that no longer exists. Check the operation of the regulator only once, ideally into a load bank or short circuit. If the condition still exists, follow the steps above.</li> <li>▪ Measure the output current with a suitable meter. If the output current is high, output current calibration values must be restored or redone.</li> </ul>
DCMU LEDs all Flashing at the same time.	<ul style="list-style-type: none"> <li>▪ Power supply card shorted.</li> <li>▪ Power supply card capacitors discharged.</li> </ul>	<ul style="list-style-type: none"> <li>▪ If all of the LEDs on a DCMU are flashing off and on simultaneously, this is because the current output from the 24 VDC on the power supply card is greater than the circuit board protection device. Remove all power from the DCMU, and then unplug the 25 pin serial cable.</li> <li>▪ Apply power to the DCMU once again, if everything is normal there is something externally connected to the DCMU that is causing the problem, this can be the serial cable, monitor card or a Megger card.</li> <li>▪ If the DCMU was operating normally, but the 24 VDC and 12 VAC connectors were removed, when they are connected again the 12 VAC should be connected first.</li> <li>▪ If there is any voltage drop on the 24 VDC lines, when first connected the inrush current can be slightly higher than the protection device on the power supply card. This is true only for older designs.</li> <li>▪ This can also sometimes occur with a spare DCMU that has been in storage for some time. If the power supply card goes into over-current, simply unplug the 24 VDC and 12 VAC connectors, and plug in the 12 VAC connector first.</li> </ul>
Output current is low for brightness step selected.	<ul style="list-style-type: none"> <li>▪ The regulator may have to be calibrated.</li> <li>▪ Regulator is overloaded.</li> </ul>	<ul style="list-style-type: none"> <li>▪ Follow the Calibration Procedure for Zero and Output Current.</li> <li>▪ If the regulator is overloaded, the output current may be low, as the regulator transformer can only output a fixed kW amount.</li> <li>▪ A quick test is to see if the output current is possible in short circuit. If the output current and voltage are properly calibrated, the output kW display will show the connected load.</li> </ul>

**Table 17: Troubleshooting Guide**

Fault	Reason	Check
Regulator turns on, but there is no output current or output is very rough and unstable.	<ul style="list-style-type: none"> <li>▪ A critical SCR setting such as Min Delay or Max Delay may have been changed.</li> <li>▪ The DCMU 12 VAC power supply wiring may have been changed</li> </ul>	<ul style="list-style-type: none"> <li>▪ If Known Good Settings were saved, restore the configuration values.</li> <li>▪ The firing of the SCRs in the power circuit is synchronized to the supply line power with the 12 VAC connection to the DCMU. The connection must have the correct instantaneous polarity as the line. If the connection is reversed for any reason, this could cause instability with the output current, or no output current. This can be corrected by changing the wiring connections on the primary or secondary of the 12 VAC supply transformer, or directly on the plug to the DCMU.</li> </ul>
Remote Control does not work, or the wrong step is being selected.	<ul style="list-style-type: none"> <li>▪ Problems with communication signals, if a communication card is used.</li> <li>▪ Problems with remote relay control</li> <li>▪ Problem with input card to DCMU from remote relays.</li> </ul>	<ul style="list-style-type: none"> <li>▪ If the DCMU is being controlled over a high speed data line, and communications is lost, the DCMU will go into Failsafe mode.</li> <li>▪ If relay control is being used, and there are complaints of a lack of control, try to operate the regulator in Local mode. If Local mode is fine, and remote relay control is being used, the external system will have to be checked.</li> <li>▪ If a proper signal is being received on the DCMU remote input relay, the corresponding LEDs will be lit on the DCMU. If the LEDs are not lit, the problem can be with the input card.</li> </ul>

## 7.0 LF8/9 CCR Parts

### 7.1 Ordering Code

#### Ordering Code

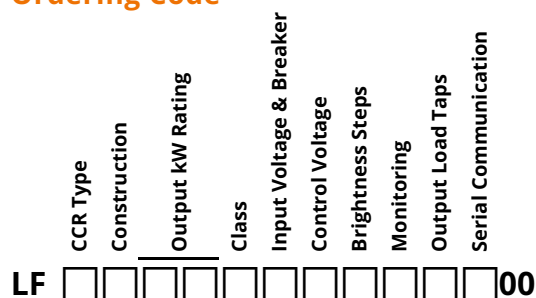

#### CCR Type

- 8 = L-828 Ferroresonant
- 9 = L-829 Ferroresonant

#### Construction

- N = Standalone

#### Output kW Rating

- 01 = 1 kW
- 02 = 2 kW
- 04 = 4 kW
- 07 = 7.5 kW
- 10 = 10 kW

#### Class

- A = 6.6 A Output

#### Input Voltage & Breaker

- 1 = 208 V, 60 Hz, without Circuit Breaker
- 2 = 240 V, 60 Hz, without Circuit Breaker
- 3 = 480 V, 60 Hz, without Circuit Breaker
- 4 = 600 V, 60 Hz, without Circuit Breaker
- 9 = 220 V, 60 Hz, without Circuit Breaker
- B = 208 V, 60 Hz, with Circuit Breaker
- C = 240 V, 60 Hz, with Circuit Breaker
- D = 480 V, 60 Hz, with Circuit Breaker
- E = 600 V, 60 Hz, with Circuit Breaker
- J = 220 V, 60 Hz, with Circuit Breaker

#### Control Voltage

- A = 24 VDC Internal
- B = 24 VDC External
- C = 48 VDC Internal
- D = 48 VDC External
- E = 120 VAC Internal
- F = 120 VAC External

#### Brightness Steps

- 1 = 1-Step
- 3 = 3-Step
- 5 = 5-Step
- A = 1-Step with Series Cutout
- B = 3-Step with Series Cutout
- C = 5-Step with Series Cutout

#### Monitoring

- 0 = Standard Monitoring (L-828/L-829)
- 1 = Input Monitoring (L-829 only)
- 2 = IRMS (L-829 only)
- 3 = IRMS & Input Monitoring (L-829 only)

#### Output Load Taps

- 0 = None

#### Serial Communication

- 0 = None
- 1 = Redundant Ethernet Network Interface
- 2 = Redundant RS485 Network Interface
- 3 = Single Ethernet Network Interface
- 4 = Single RS485 Network Interface
- 5 = Single Ethernet & Single RS485

### 7.2 CCR Kits

Various kits are available to customize CCRs for specific application requirements.

Castor Kit, 10-30 kW Only	See: "Caster Kit (94A0733) Installation".
Floor Mounting/Stacking Kit	Call ADB SAFEGATE



#### Note

All CCRs can be stacked to save floor space. Regulators up to 7.5 kW can be stacked 3 units high using the floor mounting / stacking C-channels. Larger regulators can be stacked 2 high.

## 7.3 Ferro Parts Diagrams

Figure 20: Ferro Component Plate Layout Diagram

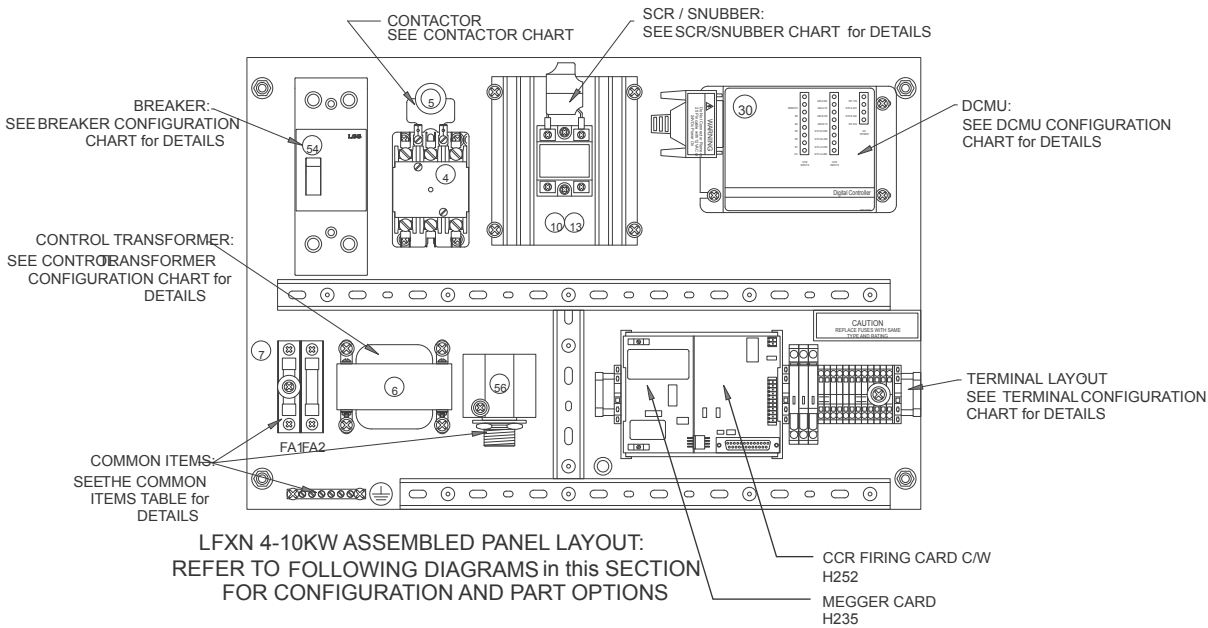

### 4-10KW - PANEL CONFIGURATIONS

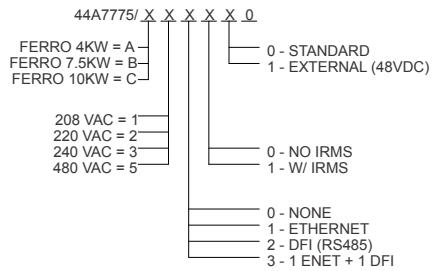

44A7775-XXXXX0 F

Figure 21: DCMU - Options

30) CONFIGURE FOR 3RD X AS FOLLOWS:

44A7775/ - - X - - 0

- 0 - NONE
- 1 - ETHERNET
- 2 - DFI (RS485)
- 3 - 1 ENET + 1 DFI

Item	Part Number	Description	EA	QTY
30	H273	DCMU CCR/PANEL NO ETH	EA	1
30	H272	DCMU CCR/PANEL A	EA	1
30	H275	DCMU CCR/PANEL RS485	EA	1
30	H789	DCMU CCR/PANEL ENET+DFI	EA	1

### DIGITAL CONTROL MONITORING UNIT (DCMU) DETAIL & CON'

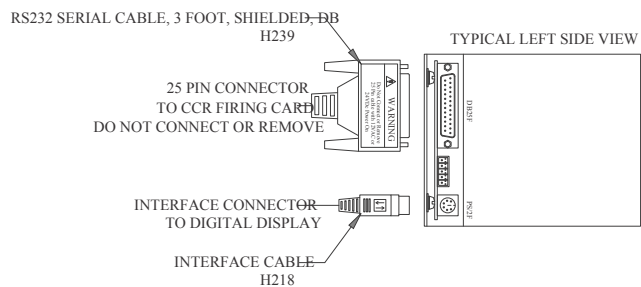

DRAWING NUMBER: 44A7775-XXXXX0 | REV. F

Figure 22: Terminal Layout

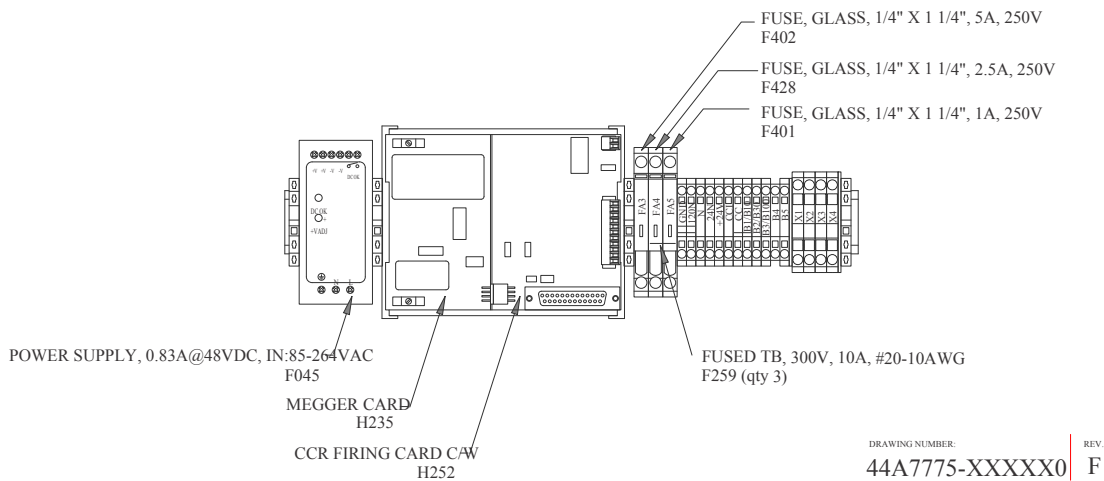
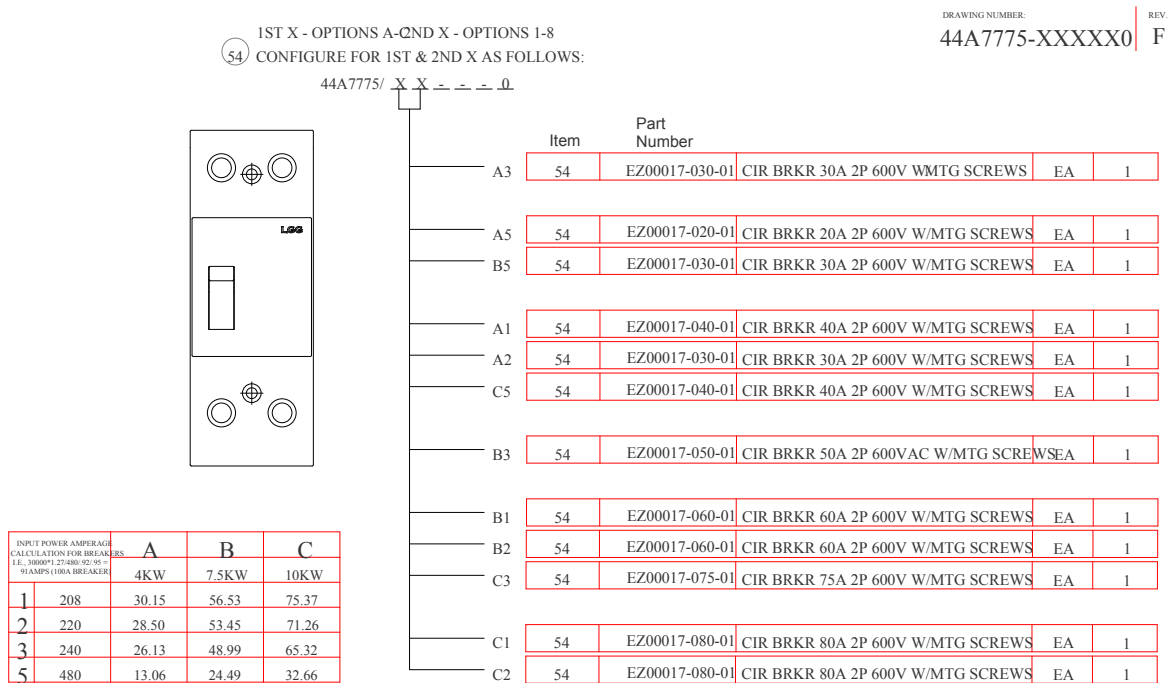
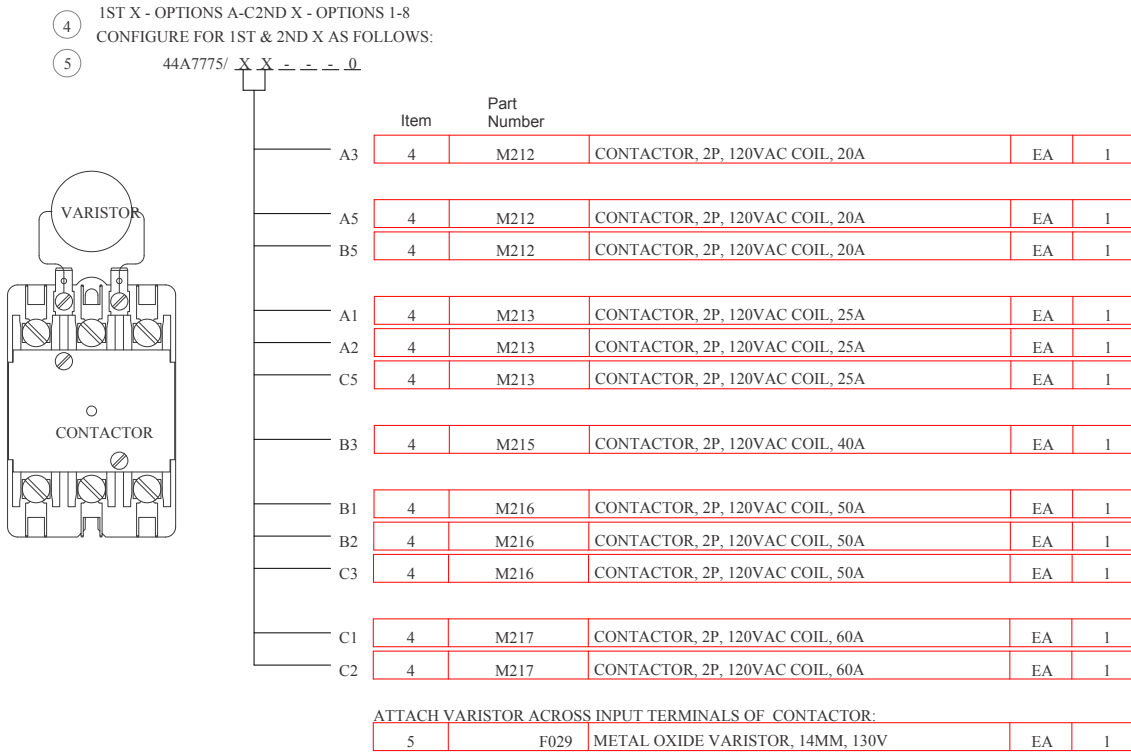

Figure 23: Breaker Selector Chart



INPUT POWER AMPERAGE CALCULATION FOR BREAKER I.E., 3000V(1.25480/0.92) = 91AMPS (100A BREAKER)	A	B	C	
1	208	30.15	56.53	75.37
2	220	28.50	53.45	71.26
3	240	26.13	48.99	65.32
5	480	13.06	24.49	32.66

**Figure 24: Contactor Selection Chart**



**Figure 25: Snubber and Transformer Selection Charts**

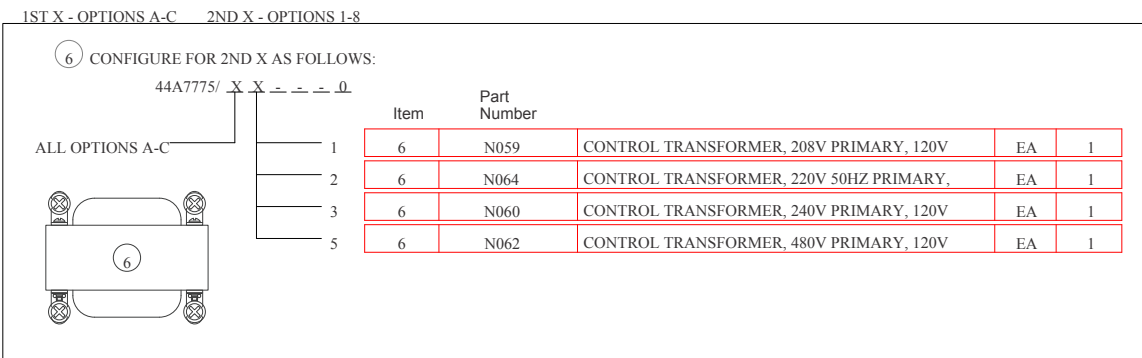
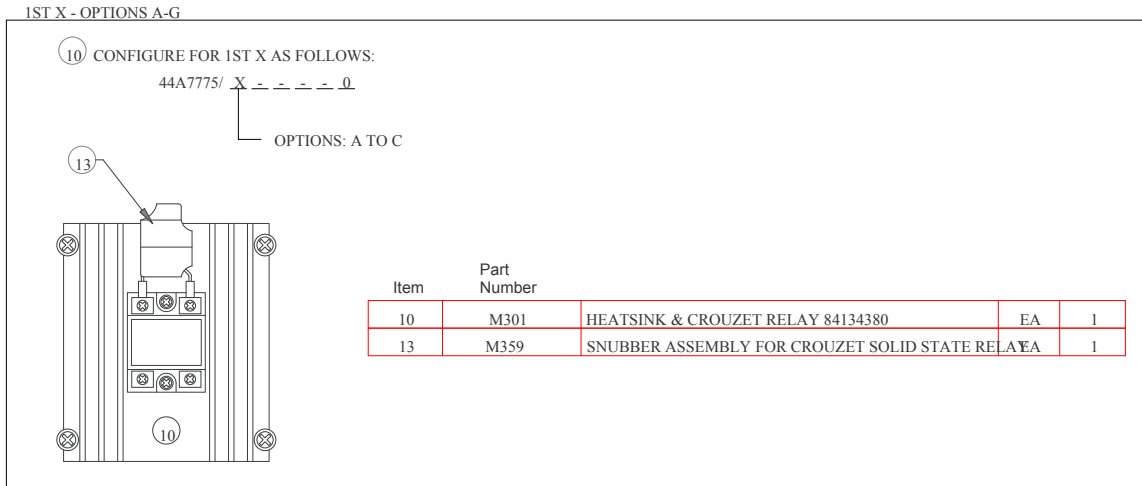

**Figure 26: Common Components Chart**

COMMON ITEMS ACROSS ALL CONFIGURATIONS - PARTS SHOWN FOR REFERENCE, ACTUAL MOUNTING ORIENTATION & LOCATION WILL VARY ON PANI

Item	Part Number	Description	EA	QTY
56	F041	SECONDARY SURGE ARRESTOR, 650V, 2 POLE	EA	1

Item	Part Number	Description	EA	QTY
12	J370	GROUND LABEL - 3/4" ROUND, PANDUIT	EA	1
27	F367	GROUND BAR, 6 CIRCUIT, #4-14 AWG CSA/UL	EA	1

Item	Part Number	Description	EA	QTY
7	49A0084	FUSEHOLDER	EA	1
9	F426	MIDGET FUSE, 250V, 5A, 10KA INTERRUPTING	EA	2

## 7.4 Ferro Spare Parts

Create a sufficiently large stock of spare parts to maintain the unit and the fixtures in the field. Consider acquiring approximately 10% spare final assemblies (with a minimum quantity of 1) for the total amount of equipment in the field. This allows for repairs to be made in the shop. Components that are more likely to need replacement, such as prisms, prism gaskets and PCB subassemblies should be stocked in smaller quantities. For a single CCR, it is highly recommended to have a least one of each spare, or for larger installations, at least 10% of the total units installed.

**Table 18: Spare Parts**

Description	PART #
Inner Mounting Panel for AD042P01 Enclosure	L916
Contactora, Definite Purpose, 2P, 120VAC Coil, 25A	M212
Contactora, ICE, 3P, 120Vac coil, 150A	M222
Metal Oxide Varistor, 14mm, 130V (old PN TMOV14R130E) new part is Lead Free	F029
Dead-front Fuse Puller, for Midget or Class CC Fuses	F441
Midget Fuse, 600v, 5A, 100KA interrupting,	F416
Midget Fuse, 250V, 5A, 10kA Interrupting	F426
SCR Assembly, 90A c/w heatsink, bus bar, snubber, barrier, assembled	M322
Surge Arrester, 3 kV (2.55KV MCOV), HD V-Star Dist. Polymer, 10 kA, Cooper, c/w cover	F042
Door Interlock Switch, SPDT, 10A 250V, Momentary with Pull to Test, Cherry E69-30A	F628
Fuse, Glass, 1/4" x 1 1/4", 5A, 250V	F414
Fuse, Glass, 1/4" x 1 1/4", 2.5A, 250V	F428
Vacuum Fluorescent Display / Keypad Assembly	H286
Interface Cable 5 Ft, Display to DSP	H218
DCMU CCR/Panel Assembly (E+8i), 24V or 120V Inputs	H272
Spirit Series DCMU Firing Card, c/w 2 Pulse Transformers - Requires External CT	H258
Current Transformer, Panel Components, 100A : 0.1A, (PMW0949-L48), 48" leads	H012
RS232 Serial Cable, 3 Foot, Shielded, DB25M to DB25M	H239
Fuse, Glass, 1/4" x 1 1/4", 1A, 250V	F401

**Table 18: Spare Parts**

Description	PART #
Secondary Surge Arrestor, 650V, 2 Pole	F041
S1 Series Plug Cutout Assembly, c/w terminal box, cover & In-Service Handle	ALSC
S1 Cutout Bracket	L925
Megger Card	H235
Megger Resistor Assembly, 2 M-ohm, 1%, 12.5W, 30" Wire Length	H777

Call your local ADB SAFEGATE representative for further information.

**Figure 27: Parts: Ferro Front Assembly**

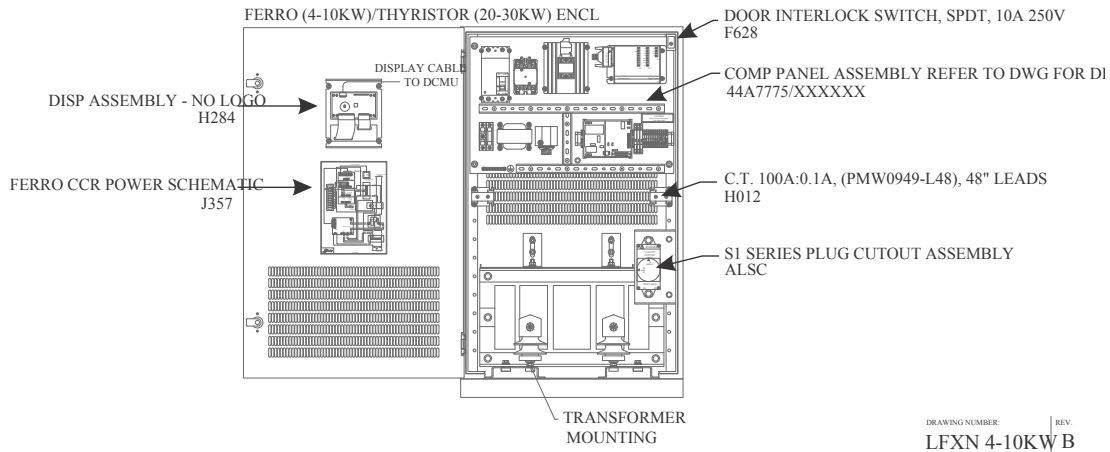

DRAWING NUMBER: LFXN 4-10KW B  
 REV.

**Figure 28: Parts: Ferro Side Assembly**

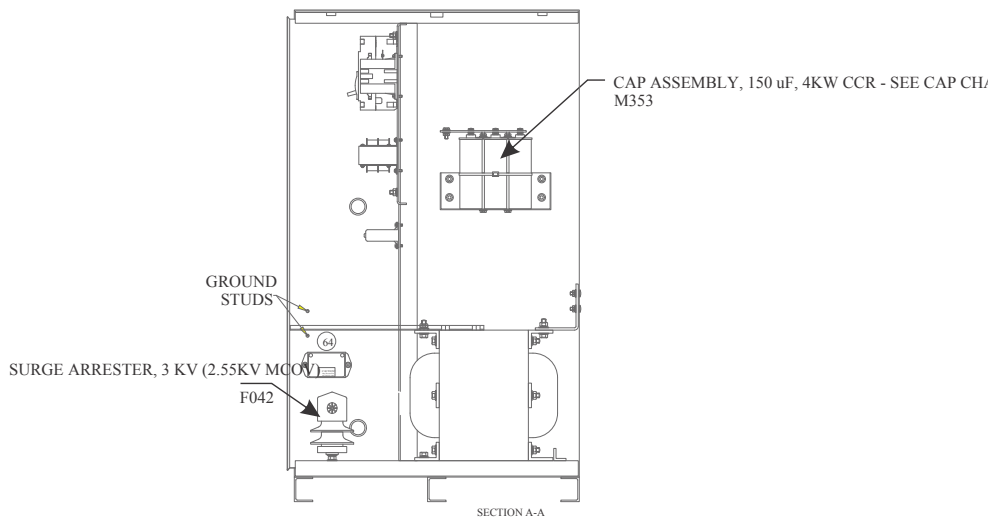

**Figure 29: Parts: Ferro cores and capacitors**

CAP CHART

11	M353	CAP ASSEMBLY, 150 uF, 4KW CCR	EA	1
	M352	CAP ASSEMBLY, 250 uF, 7.5KW CCR		
	M351	CAP ASSEMBLY, 300 uF, 10KW CCR		

## Appendix A: SUPPORT

Our experienced engineers are available for support and service at all times, 24 hour/7 days a week. They are part of a dynamic organization making sure the entire ADB SAFEGATE is committed to minimal disturbance for airport operations.

### ADB SAFEGATE Support

#### Technical Support – Global

Customers in Europe, the Middle East, Africa or Asia Pacific are more than welcome to our portal for technical support. Trained in all areas of system issues, troubleshooting, quality control and technical assistance, our highly experienced Technical support specialists are available 24 hours a day, seven days a week to provide assistance over the phone. In the Americas, we also offer live technical support.

#### Live Technical Support – Americas

If at any time you have a question or concern about your product, contact ADB SAFEGATE's US-based technical support specialists, available 24 hours a day, seven days a week, to assist you via phone.

ADB SAFEGATE Americas Technical Service & Support (US & Canada) : **+1-800-545-4157**

ADB SAFEGATE Americas Technical Service & Support (Canada): **+1-905-631-1597**

ADB SAFEGATE Americas Technical Service & Support (International): **+1-614-861-1304**

We can also be reached via email during regular business hours:

Airfield and Gate: **techservice.us@adbsafegate.com**

Gate: **gateservice.us@adbsafegate.com**

We look forward to working with you!

#### Before You Call

When you have an airfield lighting or system control system problem, prior to calling, please ensure the following:

- Review the product's manual and troubleshooting guide.
- Be located with the product ready to troubleshoot.
- Have all necessary information available: airport code/company name, customer id number, contact phone number/email address, product/part number.
- Have a True RMS meter available and any other necessary tools.

When calling about an issue with Safedock A-VDGS, we can serve you better if you collect the following information before you call:

- Relevant information regarding the issue you are calling about, such as gate number, flight number, aircraft type and time of the event.
- What, if any, actions have been taken to resolve the issue prior to the call.
- If available, provide a CCTV recording of the incident to aid in aligning the information from the Safedock log file.

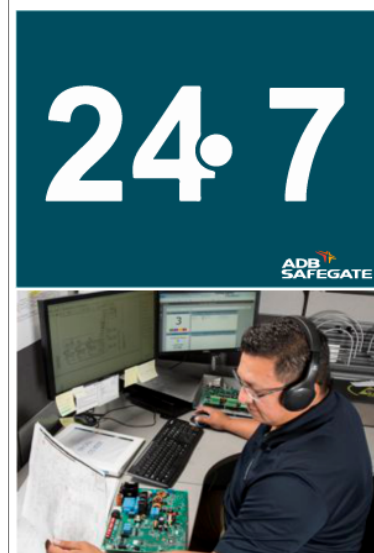

### Note

For more information, see [www.adbsafegate.com](http://www.adbsafegate.com), contact ADB SAFEGATE Support via email at [support@adbsafegate.com](mailto:support@adbsafegate.com) or Europe: +32 2 722 17 11

Americas: +1 614 861 1304. Press 3 for technical service or press 4 for sales support.

China: +86 (10) 8476 0106

Middle East and Africa: +971 4 452 7575

## A.1 ADB SAFEGATE Website

The ADB SAFEGATE website, [www.adbsafegate.com](http://www.adbsafegate.com), offers information regarding our airport solutions, products, company, news, links, downloads, references, contacts and more.

## A.2 Recycling

### A.2.1 Local Authority Recycling

The disposal of ADB SAFEGATE products is to be made at an applicable collection point for the recycling of electrical and electronic equipment. The correct disposal of equipment prevents any potential negative consequences for the environment and human health, which could otherwise be caused by inappropriate waste handling. The recycling of materials helps to conserve natural resources. For more detailed information about recycling of products, contact your local authority city office.

### A.2.2 ADB SAFEGATE Recycling

ADB SAFEGATE is fully committed to environmentally-conscious manufacturing with strict monitoring of our own processes as well as supplier components and sub-contractor operations. ADB SAFEGATE offers a recycling program for our products to all customers worldwide, whether or not the products were sold within the EU.

ADB SAFEGATE products and/or specific electrical and electronic component parts which are fully removed/separated from any customer equipment and returned will be accepted for our recycling program.

All items returned must be clearly labeled as follows:

- For RoHS/WEEE Recycling
- Sender contact information (Name, Business Address, Phone number).
- Main Unit Serial Number.

ADB SAFEGATE will continue to monitor and update according for any future requirements for EU directives as and when EU member states implement new regulations and or amendments. It is our aim to maintain our compliance plan and assist our customers.



