

Installation & Mounting

Eurobase MSB

Shallow bases and accessories



Fig. 1 12" Eurobase

Compliance with Standards

FAA: Requirements of AC 150/5345 – 46 (and 42) for direct mounting of inset lights (class 1)

Uses

- Shallow bases are used to install inset lights in flexible and non-flexible pavements, by means of the glue-in method.
- The mounting accessories provide a user-friendly solution for an easy and foolproof installation

Features

- With the ADB inset light mounted on top, the base forms a mechanically solid system for both, runway and taxiway applications
- Withstands highest possible mechanical forces and stresses, often far in excess of standard requirements.
- Optimised thermal dissipation has a positive influence on the lifetime of the components of the fitting mounted on top.
- The depth of the shallow bases is the result of an optimum compromise between the fitting height and the thickness of most pavement constructions.
- Patented plug-in feed-through contact saves one secondary connector kit and reduces connection time shallow-base-to-circuit to a minimum.
- Multiple entry arrangement allows optimisation to site wiring system.
- Light weight eases handling in the field.
- No galvanic reactions. Made of the same durable aluminium alloy as the ADB inset lights.
- Can be obtained for various M10 and UNC fixing arrangement.
- Designed for shortest possible installation time.
- For use in wet or dry systems

Construction (Fig. 2)

The shallow base is a gravity-cast aluminium alloy base out of one piece. All bases are provided with earthing facility outside and inside. The standard availability is with either one or two side entries for the cable, via the ADB Safegate patented feed-through contact plugs integrated in the side wall of the base, or by means of compression glands. In the first case the base is equipped with 0,5 m long pigtail wires for an easy (crimping) connection to the wires in the saw cuts.

For wet systems the central 100 mm hole in the bottom is another possibility. All bases are supplied with their fixing hardware: six M10 or UNC screws, or studs and self-locking nuts in case of 12" bases, two with 8" bases. In the latter case two anti-rotation pins prevent rotation and lift-off of the fitting when one of the bolts brakes off.

Upon request the hardware may be fitted into stainless steel helicoils.

Installation (Fig. 3-4)

The base is sealed by means of an appropriate resin that maintains certain flexibility after having cured. A dedicated jig with sighting telescope allows for a correct positioning and levelling of the base with or without the light fitting mounted on top. The secondary wires between the light and the isolating transformer are installed in saw cuts in the pavement filled with resin. Secondary cabling can be run in conduits underneath the base.

In the latter case the base is open from the bottom and the plug(s) of the fitting is (are) directly connected to the secondary cable coming from the transformer

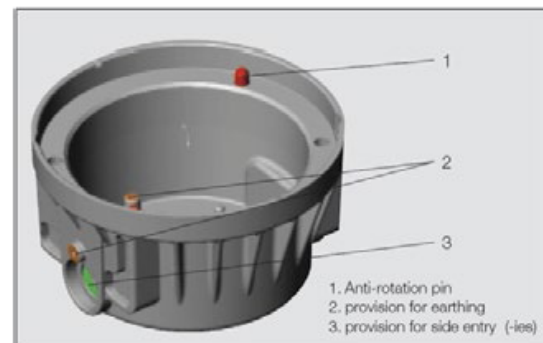

Fig. 2 Base details (here shown on a 8" HPI type)

Installation & Mounting

Eurobase MSB

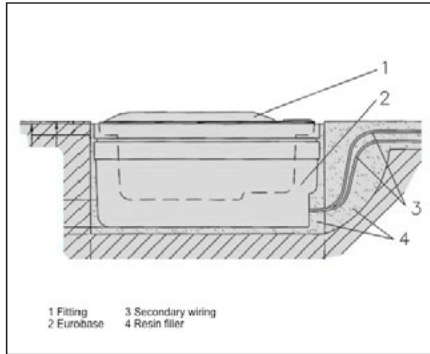

Fig. 3 Installation of a 12" Eurobase

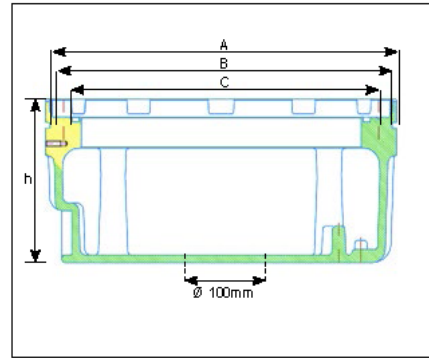

Fig. 5 Dimensions 12" Eurobase

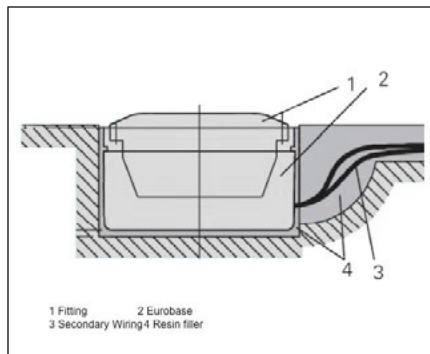

Fig. 4 Installation of an 8" Eurobase

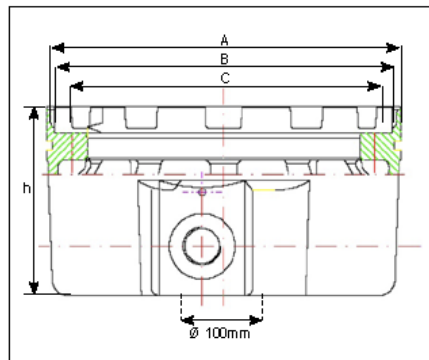

Fig. 6 Dimensions 8" Eurobase

Dimensions (Fig. 5-6)

Nominal diameter	A	B	C	h
8"	214	207	184	115
12"	318	306	286	150

Weight and volume

The Eurobase is either packed individually or, for larger quantities, individually protected in larger cardboard boxes

Base type	Condition	Volume (mm)	Weight (kg)
8"	unpacked	dia 216×115	2,5
	packed per pce	225×225×120	2,8
12"	unpacked	dia 318×150	6,85
	packed per pce	350×350×170	7,35

Accessories

Covers: blind wooden cover for temporary installation of the bases, without their fittings:

8" : 4071.86.050

12" : available upon request

Blind aluminum cover

Use for a durable watertight protection of the base:

8" : 1411.19.950

12" : 1411.88.061

Blind steel cover

8" : 1411.19.700 (UNC screws)

8" : 1411.19.710 (including 4071.76.660 steel cover, M10 metric screws and washers)

Installation jigs:

Jig : 1411.19.260, Simplified installation jig (Fig.8)

Jig : 1411.19.251, Sighting telescope with support for mounting onto the installation jigs. The telescope can be moved from one jig to another, only one required for a number of installation jigs. (Fig.7)

Ordering Code

MSB X X X X 000 3

Type

MSB = Mounting Shallow Base

Fitting Version

A = 8" Eurobase

B = 12" Eurobase

C = 8" HPI base

Fixing hardware

- For 8" Shallow Bases

0 = M10 screw fixing kit with nylon encapsulated washers¹

1 = M10 screw fixing kit

2 = M10 self-locking nut fixing kit

3 = 3/8 x 16UNC screw + anti-rotation pins fixing kit²

- For 12" Shallow Bases

4 = (6) 3/8 x 16UNC screw fixing kit

5 = (6) M10 screw fixing kit

6 = M10 screw fixing kit with nylon encapsulated washers¹

7 = (6) M10 self-locking nut fixing kit

Type of entries

0 = Central bottom hole 100mm dia

1 = Single side entry

2 = Double side entry

5 = With central bottom hole with "extension pot" for 1 cable entry

6 = With central bottom hole with "extension pot" for 2 cable entries

9 = Single side entry (and milled inside base bottom)³

A = Central bottom hole 100mm dia (and milled inside base bottom)³

Entry accessories

0 = None

1 = Feed through without earthing

2 = Feed through with earthing

3 = Compression gland PG16 for 2 core cable (OD 8 to 15mm)

4 = Compression gland PG16 for 3 single wires

5 = Compression gland PG16 for 2 single wires

Fixed digit

Y = extra earthing screws in and outside

Fixed digits

000

Version

3 = Original version



Fig. 7 Sighting telescope



Fig. 8 Installation Jig

Ordering Code Notes

Notes:

- For German versions. Those bases are supplied with:
 - anti-rotation pins mounted (in 8" Eurobase)
 - through passing fixation holes
- Not for HPI
- Execution for FFL flashing light

Important Note:

For reasons of structural integrity, ADB Safegate recommends the installation of fittings and bases from the same supplier. ADB Safegate will not assume responsibility for failures in case of mixed installation.