



ALSF/MALSR 2000 V System

Medium Intensity Approach Lighting System (MALSR) and
Approach Lighting System with Sequenced Flashers (ALSF)

Spare Parts List

SP-1037, Rev. E, 2025-11-21

**ADB
SAFEGATE**

A.0 Disclaimer / Standard Warranty

CE certification

The equipment listed as CE certified means that the product complies with the essential requirements concerning safety and hygiene. The European directives that have been taken into consideration in the design are available on written request to ADB SAFEGATE.

ETL certification

The equipment listed as ETL certified means that the product complies with the essential requirements concerning safety and C22.2 No.180:13 (R2018) regulations. The CSA directives that have been taken into consideration in the design are available on written request to ADB SAFEGATE.

All Products Guarantee

ADB SAFEGATE will correct by repair or replacement per the applicable guarantee below, at its option, equipment or parts which fail because of mechanical, electrical or physical defects, provided that the goods have been properly handled and stored prior to installation, properly installed and properly operated after installation, and provided further that Buyer gives ADB SAFEGATE written notice of such defects after delivery of the goods to Buyer. Refer to the Safety section for more information on Material Handling Precautions and Storage precautions that must be followed.

ADB SAFEGATE reserves the right to examine goods upon which a claim is made. Said goods must be presented in the same condition as when the defect therein was discovered. ADB SAFEGATE further reserves the right to require the return of such goods to establish any claim.

ADB SAFEGATE's obligation under this guarantee is limited to making repair or replacement within a reasonable time after receipt of such written notice and does not include any other costs such as the cost of removal of defective part, installation of repaired product, labor or consequential damages of any kind, the exclusive remedy being to require such new parts to be furnished.

ADB SAFEGATE's liability under no circumstances will exceed the contract price of goods claimed to be defective. Any returns under this guarantee are to be on a transportation charges prepaid basis. For products not manufactured by, but sold by ADB SAFEGATE, warranty is limited to that extended by the original manufacturer. This is ADB SAFEGATE's sole guarantee and warranty with respect to the goods; there are no express warranties or warranties of fitness for any particular purpose or any implied warranties of fitness for any particular purpose or any implied warranties other than those made expressly herein. All such warranties being expressly disclaimed.

Standard Products Guarantee

Products manufactured by ADB SAFEGATE are guaranteed against mechanical, electrical, and physical defects (excluding lamps) which may occur during proper and normal use for a period of two years from the date of ex-works delivery, and are guaranteed to be merchantable and fit for the ordinary purposes for which such products are made.



Note

See your applicable sales agreement for a complete warranty description.

Replaced or repaired equipment under warranty falls into the warranty of the original delivery. No new warranty period is started for these replaced or repaired products.

FAA Certified products manufactured by ADB SAFEGATE

ADB SAFEGATE L858 Airfield Guidance Signs are warranted against mechanical and physical defects in design or manufacture for a period of 2 years from date of installation, per FAA AC 150/5345-44 (applicable edition).

ADB SAFEGATE LED products (with the exception of obstruction lighting) are warranted against electrical defects in design or manufacture of the LED or LED specific circuitry for a period of 4 years from date of installation, per FAA EB67 (applicable edition). These FAA certified constant current (series) powered LED products must be installed, interfaced and powered with and through products certified under the FAA Airfield Lighting Equipment Program (ALECP) to be included in this 4 (four) year warranty. This includes, but is not limited to, interface with products such as Base Cans, Isolation Transformers, Connectors, Wiring, and Constant Current Regulators.



Note

See your sales order contract for a complete warranty description.

Replaced or repaired equipment under warranty falls into the warranty of the original delivery. No new warranty period is started for these replaced or repaired products.

Liability



WARNING

Use of the equipment in ways other than described in the catalog leaflet and the manual may result in personal injury, death, or property and equipment damage. Use this equipment only as described in the manual.

ADB SAFEGATE cannot be held responsible for injuries or damages resulting from non-standard, unintended uses of its equipment. The equipment is designed and intended only for the purpose described in the manual. Uses not described in the manual are considered unintended uses and may result in serious personal injury, death or property damage.

Unintended uses, includes the following actions:

- Making changes to equipment that have not been recommended or described in this manual or using parts that are not genuine ADB SAFEGATE replacement parts or accessories.
- Failing to make sure that auxiliary equipment complies with approval agency requirements, local codes, and all applicable safety standards if not in contradiction with the general rules.
- Using materials or auxiliary equipment that are inappropriate or incompatible with your ADB SAFEGATE equipment.
- Allowing unskilled personnel to perform any task on or with the equipment.

Copyright Statement

This manual or parts thereof may not be reproduced, stored in a retrieval system, or transmitted, in any form or by any means, electronic, mechanical, photocopying, recording, nor otherwise, without the author's prior written consent.

This manual could contain technical inaccuracies or typographical errors. The author reserves the right to revise this manual from time to time in the contents thereof without obligation of the author to notify any person of such revision or change. Details and values given in this manual are average values and have been compiled with care. They are not binding, however, and the author disclaims any liability for damages or detriments suffered as a result of reliance on the information given herein or the use of products, processes or equipment to which this manual refers. No warranty is made that the use of the information or of the products, processes or equipment to which this manual refers will not infringe any third party's patents or rights. The information given does not release the buyer from making their own experiments and tests.

Table of Contents

1.0 Introduction	1
1.1 High-Intensity Approach Lighting System	5
1.2 Medium-Intensity Approach Lighting System.....	14
2.0 Parts	25
2.1 ALSF/MALSR Ordering Codes	26
2.1.1 ALSF Master Control Cabinet.....	0
2.1.2 Individual Control Cabinet (ICC).....	0
2.1.3 Spare Parts Trunk.....	0
2.1.4 Aiming Device	0
2.1.5 MALSR Master Control Cabinet.....	0
2.1.6 Elevated Flasher	0
2.2 ALSF/MALSR Parts List	27
2.2.1 ALSF/MALSR Primary Control Cabinet Common Parts List.....	27
2.2.2 MALSR Primary Control Cabinet Specific Parts List.....	30
2.2.3 Flashing Light Assembly Parts List.....	30
2.2.4 Individual Control Cabinet Parts List.....	31
2.2.5 Steady Burning Light Assembly Parts List.....	34
2.2.6 MALSR PAR-38 Lampholder Assembly Parts List.....	34
2.2.7 ALSF/MALSR In-pavement Flasher (without PCB) Parts List.....	34
2.2.8 ALSF/MALSR In-pavement Flasher (with PCB) Parts List.....	36
2.2.9 ALSF/MALSR In-pavement Optical Assembly Parts List	37
2.2.10 Optional Parts.....	40
2.2.11 Separate Line Item Optional Parts	41
2.2.12 Separate Line Items Required Parts List.....	41
2.2.13 Recommended Spare Parts.....	41
2.2.13.1 Primary Control Cabinet Spare Parts.....	42
2.2.13.2 Flashing Light Assembly Spare Parts	42
2.2.13.3 Individual Control Cabinet Spare Parts	42
2.2.13.4 In-pavement Flasher Spare Parts.....	42
2.2.13.5 In-pavement Flasher Optical Assembly Spare Parts.....	42
A.0 SUPPORT	43
A.1 ADB SAFEGATE Website.....	43
A.2 Recycling	44
A.2.1 Local Authority Recycling	44
A.2.2 ADB SAFEGATE Recycling	44

List of Figures

Figure 1: Common ALSF-2 and MALSR Configurations	2
Figure 2: ALSF Configurations	3
Figure 3: MALSR Configurations	4
Figure 4: MALSR Primary Control Cabinet	28
Figure 5: ALSF Primary Control Cabinet (Standard 120/240 Vac System)	29
Figure 6: ALSF Primary Control Cabinet (Optional 240/480 Vac System)	30
Figure 7: Flashing Light Assembly	31
Figure 8: Individual Control Cabinet (Elevated Flasher Only).....	32
Figure 9: Individual Control Cabinet (In-Pavement Flasher Only).....	33
Figure 10: MALSR PAR-38 Lamp Holder Assembly Spare Parts	34
Figure 11: In-pavement Flasher Assembly (without PCB) Reference Only	36
Figure 12: In-pavement Flasher Assembly (with PCB)	37
Figure 13: In-pavement Flasher Optical Assembly (Side View)	39
Figure 14: In-pavement Flasher Optical Assembly (Detail A and Detail B)	40
Figure 15: In-pavement Flasher Optical Assembly (Top View)	40

List of Tables

Table 1: Main Differences Between ALSF and MALSR.....	1
Table 2: Flashing Light Assembly Part Numbers.....	31
Table 3: Flashing Light Assembly Part Numbers.....	31

1.0 Introduction

This section describes the ADB Safegate High Intensity Approach Lighting System with Sequenced Flashing Lights (ALSF) and the Medium Intensity Approach Lighting System with Sequenced Flashing Lights (MALSRS). The ALSF and MALSRS are manufactured according to specification FAA-2628 and FAA-E-2325 respectively. Refer to [Table 1](#) for the main differences between the ALSF and MALSRS lighting systems. Refer to [ALSF/MALSRS: Required Equipment](#) for details concerning equipment differences.

Table 1: Main Differences Between ALSF and MALSRS

ALSF	MALSRS
FAA-E-2628 specification	FAA-E-2325 specification
Up to 21 flashers	3, 5, or 8 flashers (optionally to 21)
Flashers only	Flashers and steady burning lamps
Misfire monitoring	Misfire monitoring optional
Steady burning lights powered from separate series circuit	Steady burning light powered from 15 kVA voltage-driven transformer

Note: The ALSF per FAA-E-2628 includes only the electronics for the sequenced flasher. The MALSRS includes both the electronics for the sequenced flasher and controls for the steady burning lights.

Figure 1: Common ALSF-2 and MALSR Configurations

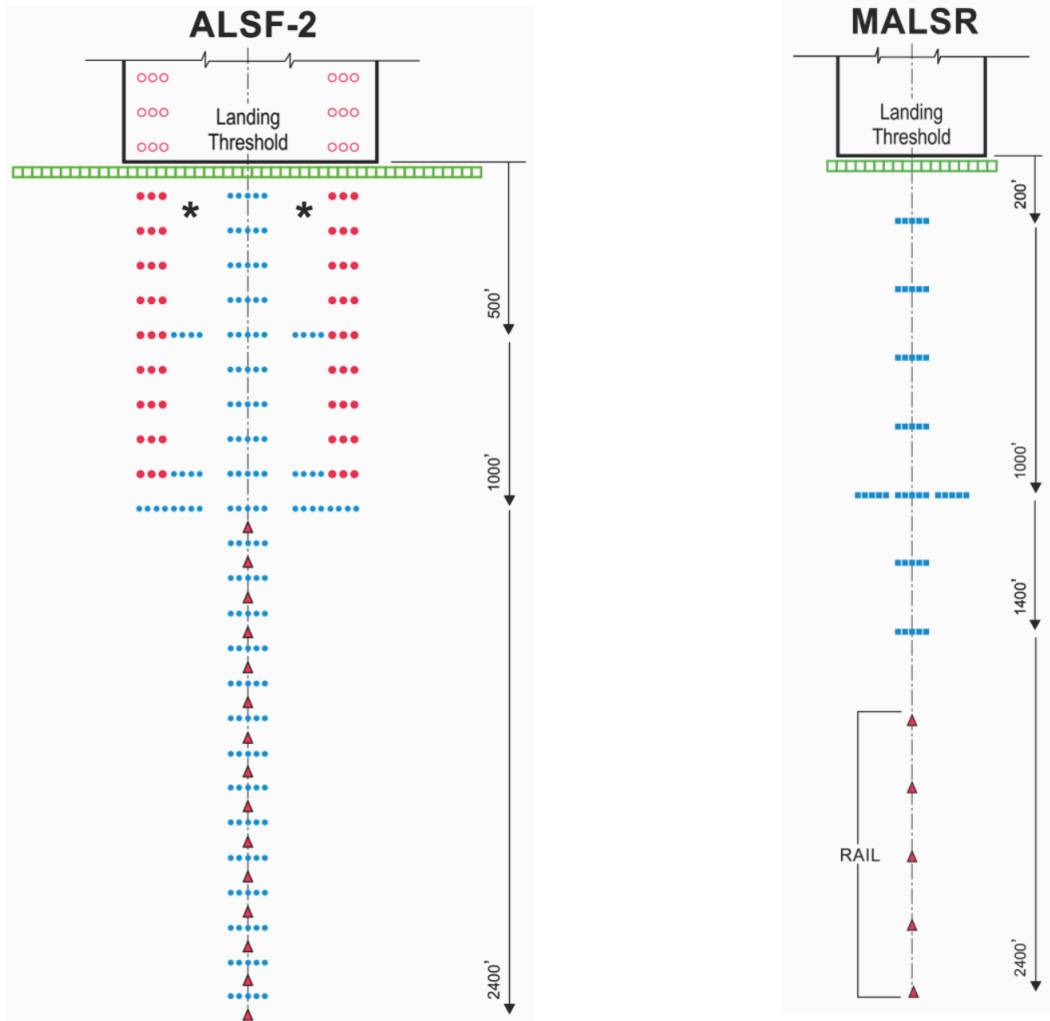
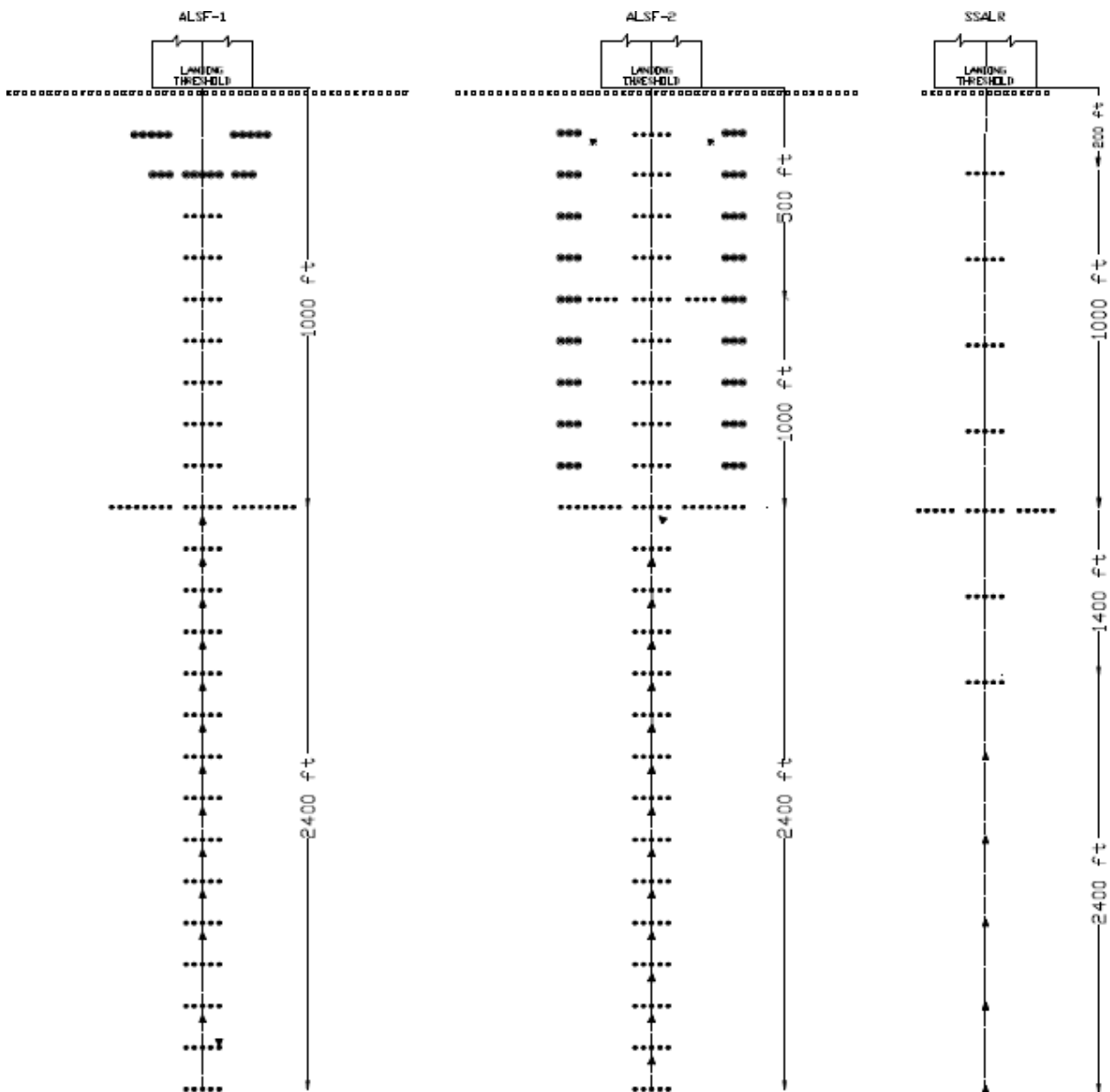
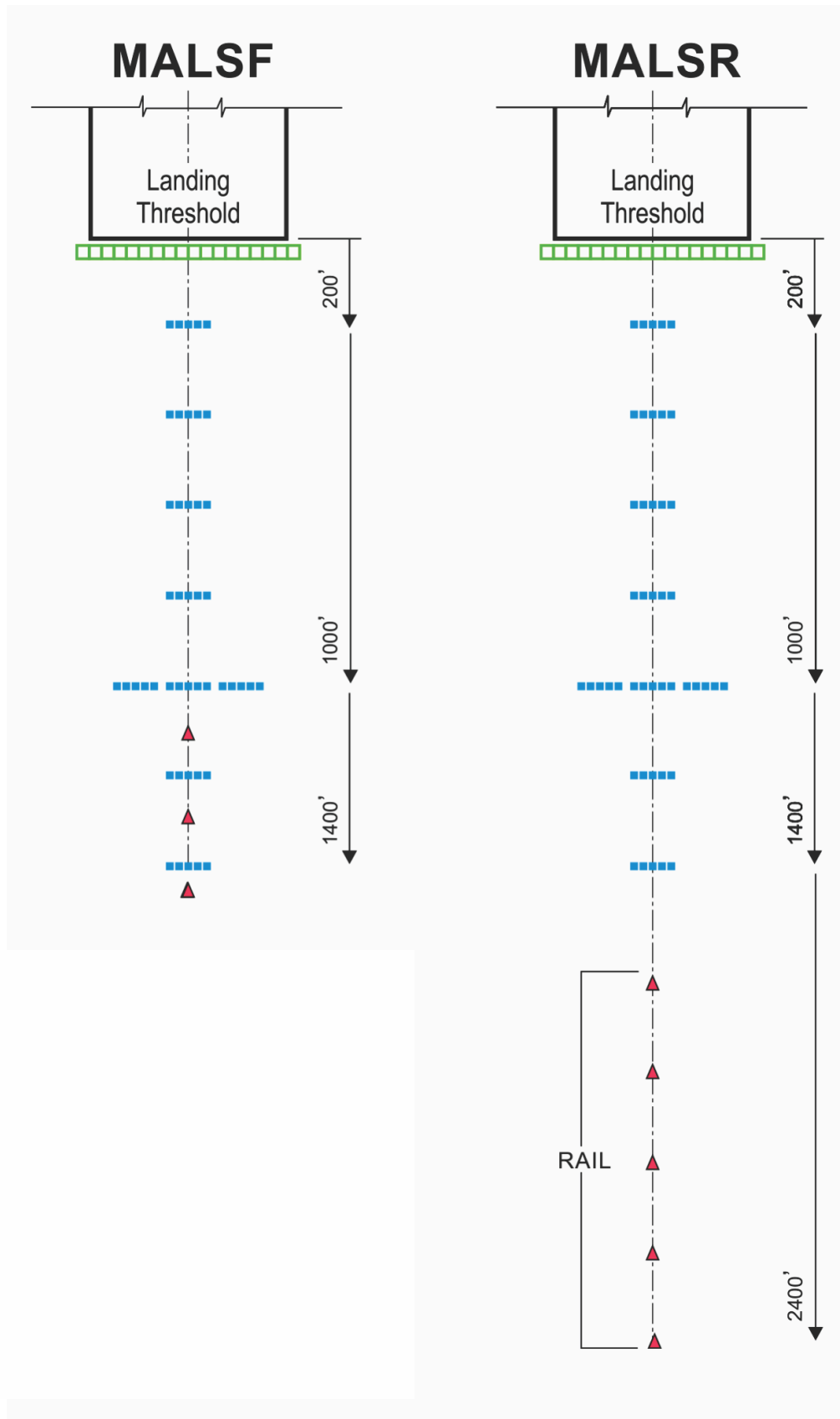

Figure 2: ALSF Configurations



Legend	
●	High Intensity Steady Burning White Lights
□	Threshold Lights
⦿	Steady Burning Red Lights
▲	Sequenced Flashing Lights
✱	Red Side Row Lights Aligned with Touchdown Zone Lights on Runway
■	Medium Intensity Steady Burning White Lights

Figure 3: MALSR Configurations



1.1 High-Intensity Approach Lighting System

Compliance with Standards

FAA	Designed according to ALSF-1, ALSF-2, ALSF-2/SSALR FAA-E-2628; FAA-E-2325 (Sequenced Flashing Components)
ICAO	Annex 14 para. 5.3.4.7, 5.3.4.15, 5.3.4.16, 5.3.4.30, and 5.3.4.31
Military	AFMAN(I) 32-1187/TM 811-5 (UFC 3-535-01) Approach Applications

Uses

ALSF-1, ALSF-2, and ALSF-2/SSALR approach lighting systems with elevated sequenced flashing lights are used at airports and military air bases to provide landing approach guidance, such as runway alignment, height perception, horizontal reference, and roll guidance extending from the landing threshold outward (2,400-3,000 feet) into the approach zone.

ALSF-1

- The ALSF-1 approach lighting system is used on Category I Instrument Landing Systems (ILS) and includes up to 24 light stations (100-foot spacing) with up to 22 centerline bars of steady-burning lights (five lights to a bar) and up to 15 flashers.

ALSF-2

- The ALSF-2 approach lighting system is used on Category II runways and includes up to 30 light stations (100-foot spacing) with 30 centerline bars of steady-burning lights (five lights to a bar) and up to 21 flashers.

SSALR

- The SSALR approach lighting system has up to eight sequenced flashing lights and is used as part of a dual-mode approach lighting system (ALSF-2/SSALR) when Category I conditions exist on Category II designated runways.

Operating Conditions

Temperature	-67 °C to +137 °C (-55 °F to +55 °F)
Humidity	0 to 100%
Altitude	0 to 10,000 ft (3048 m) maximum

Theory of Operation

ADB SAFEGATE's sequenced-flasher lighting systems include a master control unit, junction boxes, individual control cabinets (ICC), and elevated flasher units. In the ALSF configuration, an array of light bars are installed symmetrically around the centerline of the approach lighting system, starting at the approach threshold and extending a total distance of 2,400 feet (731.5 m) outward into the approach zone up to 3,000 feet (914 m) at facilities where high-speed military aircraft share runway usage. Up to 21 flashing lamp assemblies are installed in the outer portion of the approach lighting system at regular intervals. Flashing lights are arranged and connected in such a way as to produce a sequenced flashing light signal that has the appearance of a ball of light traveling down the system from the outer end (flasher farthest from the runway threshold) to the flasher assembly closest to the runway threshold.

ALSF Master Control Cabinet

The master control cabinet contains control circuitry and monitoring PCBs, which provide the power, timing signals, misfire monitoring circuitry, and three-step intensity control signals to the sequenced flasher assemblies in remote (120 VAC or +48 VDC control) and local mode. The master cabinet can control up to 21 sequenced flasher assemblies, providing power and trigger signals to produce a sequenced flashing light signal having the appearance of a ball of light traveling down the approach zone.



Equipment Data

Input and Output Voltage	120/240 VAC, +10%, 60 Hz, three-wire, Voltage single-phase (neutral center-tapped). Optional input: 480 VAC, +10%, 60 Hz, two-wire, single-phase.
Output Trigger Pulses	Time-synchronized with the 60 Hz line
Time from Trigger Pulse to Trigger Pulse	In ALSF mode, corresponds to one cycle of 60 Hz line, 16.67 ms. In SSALR mode, corresponds to every other cycle of the 60 Hz line or 33.3 ms.
Modes of Operation	Manual (local) control and remote control (+48 VDC or 120 VAC)
Enclosure	NEMA 4, outdoor and ventilated (to prevent condensation)
Maintenance Features on Control Cabinet	<ul style="list-style-type: none"> ▪ Rotary control switch for manual control of brightness level of system ▪ Flasher ON/OFF switch to de-energize flashers (if desired) when the approach lights are energized ▪ LED indicators on control panel for system monitoring ▪ Service entrance switch disconnects incoming power to the control unit ▪ 100 W maintenance light ▪ Door can be locked in a 120° open position
Lightning Protection	Rugged surge protection on all input and output electrical connections

Input Power Requirement

Voltage	Maximum Number of Flashers	Maximum Power Requirements
120/240 VAC	3	4 kVA
	6	5 kVA
	9	6 kVA
	12	7 kVA
	15	8 kVA
	18	9 kVA
	21	10 kVA
480 VAC	12	7.5 kVA
	21	11 kVA

Packaging Information

	Dimensions	Gross Weight
120/240 VAC (standard)	37.25 x 30 x 11.38 in	137 lb
	94.6 x 76.2 x 28.9 cm	62 kg
480 VAC	48 x 36 x 16.38 in	279 lb
	125.1 x 91.4 x 41.6 cm	126.6 kg

Individual Control Cabinet (ICC)

Each flasher unit is controlled by an individual control cabinet, which houses triggering circuits, terminal blocks, and lightning arrestors. A safety interlock switch is incorporated into the enclosure to discharge the high-voltage circuitry when the cabinet door is opened.



Equipment Data

Quantity	One for each flash unit
Enclosure	Outdoor, door handle can be padlocked
Input Voltage	120/240 VAC, 60 Hz, three-wire, (neutral center-tapped). Voltage range for operation is 185-260 VAC.
Input Current	1 A in high intensity (average)
Flash Lamp Output Voltage	+2,000 VDC
Maximum Power Consumption	250 W or less
Intensity Step Change Component Life	150,000 operations minimum
Protection	Rugged surge protection on all external wiring connections
Mounting	Two 2-inch (5.08 cm) threaded fittings are provided on bottom of cabinet for mounting. Mounting lugs are also provided on the back of the cabinet.
Installation Distance	ICC can be installed a maximum of 2,400 ft (370 m) from master control cabinet. Contact ADB for distances over 2,400 ft.
Dimensions	20 x 16 x 8 in (50.8 x 40.64 x 20.3 cm)
Weight	57 lb (25.85 kg)

Elevated Flasher

Each elevated flash head assembly consists of a flashing light head, which houses a PAR-56 flashtube and a trigger transformer. A safety interlock switch is incorporated in the flash head. It works in conjunction with the individual control cabinet (ICC) interlock switch to discharge the voltage across the flash lamp when either the ICC door is opened or the flash-tube is removed.



Note

120 W, 2000 VAC, PAR-56 Xenon lamp included. For replacement lamps, use part number 48B0022.

Equipment Data

Input Voltage	+2,000 VDC
Lamp	PAR-56 xenon flashtube
Lamp Life	Average 1,000 hours on high-intensity step
Intensity Decrease	30% or less over minimum rated lamp life
Flash Duration	40-100 microseconds
Flash Skipping	Less than 1% with no consecutive skipping
Light Beam Axis	Adjustable vertically from the horizontal to 25° above the horizontal
Vibration	Withstands vibration in frequency range of 10 to 2,000 Hz in accordance with NEMA Standard FA1-3.01
Enclosure	Rain tight
Mounting	On a 2-in (5.08 cm) frangible coupling or 2-in EMT conduit, or 1.5-inch (3.81 cm) OD tube or 1.5-inch schedule 40 pipe. Mounting can be on a 1-in (2.54 cm) pipe (used on an aluminum tower) using adapter sleeve.
Installation Distance	A maximum of 60 ft (18.3 m) from ICC
Dimensions	13.33 x 6.25 x 8.31 in (33.86 x 15.88 x 21.11 cm)
Weight	4 lb (1.8 kg)

Elevated Flasher Photometric Data

Intensity Setting	Flashtube Intensity	
	Max. Effective Intensity	Min. Effective Intensity
High	20,000 cd	8,000 cd
Medium	2,000 cd	800 cd
Low	450 cd	150 cd

In-Pavement Flasher

In-pavement flashers are not available with this system. If in-pavement flashers are required, see DST-2091.

Junction Box

Junction boxes are used to distribute power and control signals to the ICCs. One junction box is required for each sequenced flasher in the system. Each junction box has two terminal strips to accommodate the incoming and outgoing power, control circuit, and monitoring wire for the flasher unit.



Steel Junction Box (Standard)	44D1653
Stainless Steel Junction Box	44D1653/1
Quantity	One for each flasher unit
Conduit Hub	Two 2-inch hubs in the bottom of the box
Dimensions	14 x 14 x 6 in (35.56 x 35.56 x 15.24 cm)
Weight	15 lb (6.8 kg)

PAR-56 Lamp Holder

Eighteen PAR-56 lamp holders are installed on the runway threshold. The lamp holder has mounting clips to hold the green filter and is designed to accommodate a 300 W, 120 VAC PAR-56 lamp. Each lamp holder has an adjustable base for vertical adjustment and mounts to a 2-inch EMT conduit or on top of a frangible coupling.



Note

Steady-burning portion of ALSF system is ordered separately. See ADB SAFEGATE PAR-56 data sheet 1042 for more details.

Aiming Device

The aiming device is used to adjust and measure the vertical elevation angle of PAR-38 and PAR-56 steady burning or flashing lamp holders. The aiming device permits aiming of the lamp axis perpendicular to the plane of the cover glass at any angle from 0° to +25° above the horizontal, even when mounted on low impact-resistant structures conforming to FAA-E-2604 or FAA-E-2702. The aiming angle is indicated on a scale calibrated in 1° intervals, and the actual aiming angle of the lamp holder with the aiming device attached is accurate to within ±0.5°.



For PAR-56 Lamp Only	44D1654/1
For PAR-56 and PAR-38 Lamps	44D1654/2

Equipment Data

Quantity	One
Aiming	Flash lamp axis can be aimed from 0° to 25° above the horizontal
Scale	Calibrated in 1° increments
Accuracy	±0.5°
Dimensions	7 dia. x 10 H in (17.78 dia. x 25.4 H cm)

Flasher Tester

The portable flasher tester is equipped with a test cable and plug, which connect to a socket in the ICC to monitor the operation of the flasher light unit. The flasher tester is capable of testing the power circuits and control signals from the master control unit to the ICC, and from the ICC to the flash head.



Flasher Tester

44D1686/1

Equipment Data

Contains	Voltmeter, pulse detector, test-signal switch, and intensity- and trigger-control switches
Test Cable	Plugs into socket in the ICC
Dimensions	9 x 17 x 10 in (22.9 x 43.2 x 25.4 cm)
Weight	3.5 lb (1.59 kg)

Spare Parts Trunk

Spare Parts Trunk includes I/O interface, Control PCB, ICC Flasher PCB, Bleeder, and Monitoring PCBs.



Note

- The spare parts trunk must be ordered separately for FAA-E-2628 applications
- Sequenced flashing components (Part No. 44A1788) are ETL Certified according to FAA-E-2325

High-Voltage Wire

12AWG Wire 3kV 105C White

89A0110/1

Ordering Information

The following equipment is supplied for the ALSF-1, ALSF-2, and ALSF-2/SSALR approach lighting systems per FAA-E-2628:

Quantity	Description
1	Master Control Cabinet
Up to 21	Flashing Light Heads
Up to 21	Individual Control Cabinets
Up to 21	Junction Boxes
1	Aiming Device
1	Flasher Tester
1	Instruction Manual

Additional equipment may be required, but must be ordered separately:

- PAR-56 Lamp Holder Assemblies
- PAR-56 Lamps
- Frangible Couplings
- Low Impact-Resistant Structures
- High-Voltage Interconnection Wire
- Spare Parts Trunk
- L-830 Isolation Transformer
- 1,500 W, 20 A/20 A, Isolation Transformer
- For in-pavement FAA-E-2952 (Replacement for 2491) ALSF high intensity system applications, see data sheet 2029 for details.

1.2 Medium-Intensity Approach Lighting System

Compliance with Standards

FAA	Designed according to MALSR FAA-E-2325
------------	--

Uses

The MALSR approach lighting system with elevated sequenced flashing lights are used at airports and military air bases to provide landing approach guidance, such as runway alignment, height perception, horizontal reference, and roll guidance extending from the landing threshold outward (2,400 feet) into the approach zone.

MALSR

- The MALSR approach lighting system is used on Category I Instrument Landing Systems (ILS) and includes up to 12 light stations (200-foot spacing) with up to 7 centerline bars of steady-burning lights (five lights to a bar) and up to 8 flashers.

Operating Conditions

Temperature Range	-67 °F to +158 °F (-55 °C to +70 °C)
Humidity	0 to 100%, condensing
Altitude	0 to 10,000 ft (3,048 m) maximum

Theory of Operation

ADB SAFEGATE's sequenced-flasher lighting system includes a master control unit, junction boxes, individual control cabinets, a 15 kVA steady-burning light transformer, and elevated flasher units. In the MALSR configuration, an array of light bars are installed symmetrically around the centerline of the approach lighting system, starting at the approach threshold and extending a total distance of 2,400 feet (731.5 m) into the approach zone and up to 3,000 feet (914.4 m) at facilities where high-speed military aircraft share runway usage. Up to 11 flashing lamp assemblies are installed in the outer portion of the approach lighting system at regular intervals. Flashing lights are arranged and connected to produce a sequenced flashing light signal that has the appearance of a ball of light traveling down the system from the outer end (flasher farthest from the runway threshold) to the flasher assembly closest to the runway threshold.

MALSR Master Control Cabinet

The master control cabinet contains control circuitry and monitoring PCBs, which provide the power, timing signals, misfire monitoring circuitry, and three-step intensity control signals to the sequenced flasher assemblies in remote (120 VAC or +48 VDC control) and local mode. The master cabinet can control up to 21 sequenced flasher assemblies, providing power and trigger signals to produce a sequenced flashing light signal having the appearance of a ball of light traveling down the approach zone.



Equipment Data

Input and Output Voltage	120/240 VAC, $\pm 10\%$, 60 Hz, three-wire, single-phase (neutral center-tapped)
Output Trigger Pulses	Time-synchronized with the 60 Hz line
Time from Trigger Pulse to Trigger Pulse	33.3 milliseconds
Modes of Operation	Manual (local) control and remote control (+48 VDC or 120 VAC)
Enclosure	NEMA 4, outdoor and ventilated (to prevent condensation)
Maintenance Features on Control Cabinet	<ul style="list-style-type: none"> ▪ Rotary control switch for manual control of brightness level of system ▪ Flasher ON/OFF switch to de-energize flashers (if desired) when the approach lights are energized ▪ LED indicators on control panel for system monitoring ▪ Service entrance switch disconnects incoming power to the control unit ▪ 100 W maintenance light ▪ Door can be locked in a 120° open position

Packaging Information

	Dimensions	Gross Weight
120/240 VAC (standard)	37.25 x 30 x 11.38 in	137 lb
	94.6 x 76.2 x 28.9 cm	62 kg
480 VAC	48 x 36 x 16.38 in	279 lb
	125.1 x 91.4 x 41.6 cm	126.6 kg

Input Power Requirements

Max. No. of Flashers	Max. Power Requirements
3	18 kVA
5	19 kVA
8	20 kVA

Individual Control Cabinet (ICC)

Each flasher unit is controlled by an individual control cabinet, which houses triggering circuits, terminal blocks, and lightning arresters. A safety interlock switch is incorporated into the enclosure to discharge the high-voltage circuitry when the cabinet door is opened.



Equipment Data

Quantity	One for each flash unit
Enclosure	Outdoor, door handle can be padlocked
Input Voltage	120/240 VAC, 60 Hz, three-wire, (neutral center-tapped). Voltage range for operation is 185-260 VAC.
Input Current	1 A in high intensity (average)
Flash Lamp Output Voltage	+2,000 VDC
Maximum Power Consumption	250 W or less
Intensity Step Change Component Life	150,000 operations minimum
Protection	Rugged surge protection on all external wiring connections
Mounting	Two 2-inch (5.08 cm) threaded fittings are provided on bottom of cabinet for mounting. Mounting lugs are also provided on the back of the cabinet.
Installation Distance	ICC can be installed a maximum of 2,400 ft (370 m) from master control cabinet. Contact ADB for distances over 2,400 ft.
Dimensions	20 x 16 x 8 in (50.8 x 40.64 x 20.3 cm)
Weight	57 lb (25.85 kg)

Elevated Flasher

Each elevated flash head assembly consists of a flashing light head, which houses a PAR-56 flashtube and a trigger transformer. A safety interlock switch is incorporated in the flash head. It works in conjunction with the individual control cabinet (ICC) interlock switch to discharge the voltage across the flash lamp when either the ICC door is opened or the flashtube is removed.



Note

Flash head includes lamp. For replacement lamp use part number 48B0022.

Equipment Data

Input Voltage	+2,000 VDC
Lamp	PAR-56 xenon flashtube
Lamp Life	Average 1,000 hours on high-intensity step
Intensity Decrease	30% or less over minimum rated lamp life
Flash Duration	0-100 microseconds
Flash Skipping	Less than 1% with no consecutive skipping
Light Beam Axis	Adjustable vertically from the horizontal to 25° above the horizontal
Vibration	Withstands vibration in frequency range of 10 to 2,000 Hz in accordance with NEMA Standard FA1-3.01
Enclosure	Rain tight
Mounting	On a 2-inch (5.08 cm) frangible coupling or 2-inch EMT conduit, or 1.5-inch (3.81 cm) OD tube or 1.5-inch schedule 40 pipe. Mounting can be on a 1-inch (2.54 cm) pipe (used on an aluminum tower) using adapter sleeve.
Installation Distance	A maximum of 60 ft (18.3 m) from ICC
Dimensions	13.33 × 6.25 × 8.31 in (33.86 × 15.88 × 21.11 cm)
Weight	4 lb (1.8 kg)

Elevated Flasher Photometric Data

Intensity Setting	Flash Tube Intensity	
	Max. Effective Intensity	Min. Effective Intensity
High	20,000 cd	8,000 cd
Medium	2,000 cd	800 cd
Low	450 cd	150 cd

In-Pavement Flasher

In-pavement flashers are not available with this system. If in-pavement flashers are required, see DST-2091.

Junction Box

Junction boxes are used to distribute power and control signals to the ICCs. One junction box is required for each sequenced flasher in the system. Each junction box has two terminal strips to accommodate the incoming and outgoing power, control circuit, and monitoring wire for the flasher unit.



Steel Junction Box (Standard)	44D1653
Stainless Steel Junction Box	44D1653/1
Quantity	One for each flasher unit
Conduit Hub	Two 2-inch hubs in the bottom of the box
Dimensions	14 x 14 x 6 in (35.56 x 35.56 x 15.24 cm)
Weight	15 lb (6.8 kg)

Standard Steel Junction Box	44D1653
Stainless Steel Junction Box	44D1653/1

Equipment Data

Quantity	One for each flasher unit
Conduit Hub	Two 2-inch hubs in the bottom of the box
Dimensions	14 × 14 × 6 in (35.56 × 35.56 × 15.24 cm)
Weight	15 lb (6.8 kg)

15 kVA Power Transformer

The 15 kVA, 60 Hz power transformer powers the steady-burning PAR-56 and PAR-38 lights. Taps on the transformer are switched by contactors in the master control cabinet to provide power at any one of three voltage levels to the steady-burning lights. Taps provided on the primary of the transformer permit secondary voltage adjustment to within 2.5% of the required secondary output assuming the primary voltage is between 210 V and 252 VAC. The transformer is housed in an outdoor, rain-tight enclosure with lugs provided on the back of the enclosure for mounting the cabinet in a vertical position. Two external lightning arresters are provided for input and output lightning protection.

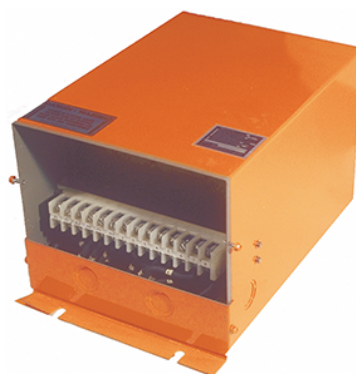

15 kVA Transformer

44D1685/1

Equipment Data

Quantity	One	
Rating	15 kVA	
Input	210-252 VAC, 60 Hz	
Taps	Provided on primary to permit adjustment of secondary voltages	
Output Voltage (240 VAC Primary Input)	<u>Intensity Step</u>	<u>Secondary Output</u>
	Low	50/100 VAC ±0.5%
	Medium	75/150 VAC ±0.5%
	High	120/240 VAC ±0.5%
Dimensions	13.25 × 12 × 18 in (33.7 × 30.48 × 45.7 cm)	
Weight	262 lb (119 kg)	

PAR-38 Lamp Holder

There are 45 PAR-38 lamp holders mounted five to a light bar in the runway approach. Each lamp holder is designed to accommodate 150 W, 120 VAC PAR-38 lamps. An adjustable base on the lamp holder permits vertical adjustment from the horizontal to 25° above the horizontal. Also, the mounting hardware permits horizontal alignment of the light beam axis to any horizontal angle within +1°. The lamp holder has a mounting base that mounts on the open top of a frangible coupling, on a light bar with an adapter sleeve, or to a 2-inch (EMT) conduit.



PAR-38 Lamp Holder

AS00061-001-02

**Note**

60 W, 120 VAC PAR-38 lamps are sold separately. Use part number EA00001-000-01.

Equipment Data

Quantity	45 total
Installation	Five PAR-38 lamp holders are installed on a light bar (Nine light bars in system)
Dimensions	9 × 3 × 3 in (22.9 × 7.6 × 7.6 cm)

LIR Adapter

An optional adapter sleeve is used to adapt the fiberglass LIR mast mountings to 2.36 in (60 mm) for the slip fitter attachment.



LIR Adapter

4762

PAR-56 Lamp Holder

Eighteen PAR-56 lamp holders are installed on the runway threshold. The lamp holder has mounting clips to hold the green filter and is designed to accommodate a 300 W, 120 VAC PAR-56 lamp. Each lamp holder has an adjustable base for vertical adjustment and mounts to a 2-inch EMT conduit or on top of a frangible coupling.



Note

PAR-56 lamp holders are ordered separately. See ADB SAFEGATE PAR-56 DS-1042 for more details.

Aiming Device

The aiming device is used to adjust and measure the vertical elevation angle of PAR-38 and PAR-56 steady burning or flashing lamp holders. The aiming device permits aiming of the lamp axis perpendicular to the plane of the cover glass at any angle from 0° to +25° above the horizontal, even when mounted on low impact-resistant structures conforming to FAA-E-2604 or FAA-E-2702. The aiming angle is indicated on a scale calibrated in 1° intervals, and the actual aiming angle of the lamp holder with the aiming device attached is accurate to within ±0.5°.



For PAR-56 Lamp Only	44D1654/1
For PAR-56 and PAR-38 Lamps	44D1654/2

Equipment Data

Quantity	One
Aiming	Flash lamp axis can be aimed from 0° to 25° above the horizontal
Scale	Calibrated in 1° increments
Accuracy	±0.5°
Dimensions	7 dia. x 10 H in (17.78 dia. x 25.4 H cm)

Flasher Tester

The portable flasher tester is equipped with a test cable and plug, which connect to a socket in the ICC to monitor the operation of the flasher light unit. The flasher tester is capable of testing the power circuits and control signals from the master control unit to the ICC, and from the ICC to the flash head.



Flash Tester

44D1686/1

Equipment Data

Contains	Voltmeter, pulse detector, test-signal switch, and intensity- and trigger-control switches
Test Cable	Plugs into socket in the ICC
Dimensions	9 × 17 × 10 in (22.9 × 43.2 × 25.4 cm)
Weight	3.5 lb (1.59 kg)

Spare Parts Trunk

Spare Parts Trunk includes I/O interface, Control PCB, ICC Flasher PCB, Bleeder, and Monitoring PCBs.



High-Voltage Wire

Used to interconnect elevated flash head and individual control cabinet. Wire is supplied in 500-foot spools only. Please specify total length (in feet) of wire required when ordering.

Ordering Information

The following equipment is supplied for the MALSR approach lighting systems per FAA-E-2325:

Quantity	Description
1	Master Control Cabinet
3 to 11	Sequence Flasher Heads
3 to 11	Individual Control Cabinets
3 to 11	Junction Boxes
1	15 kVA Power Transformer
2	Lightning Arresters
45	PAR-38 Lamp Holders
18	PAR-56 Lamp Holders
1	Flasher Tester
A/R	High-Voltage Interconnecting Wire (flash head to ICC)
1	Aiming Device (PAR-38/-56)
1	Spare Parts Trunk
2	Instruction Manual



Note

Sequenced flashing components (Part No. 44A1788) are ETL Certified according to FAA-E-2325

Additional equipment may be required, but must be ordered separately:

- PAR-38, 150 W, 120 VAC spot lamps
- PAR-56, 300 W, 120 VAC spot lamps
- Frangible couplings
- Low impact-resistant structures
- For in-pavement FAA-E-2968 MALSR medium-intensity system, Style I, unidirectional white applications, use part number 44A6440-2000. This fixture uses one 105W lamp and is photometrically equivalent to the older style 200W L-850B fixtures that were used in this application. See data sheet 2029 for details.
- Encapsulated (FAA Style) isolation transformers are available for voltage-driven, medium-intensity approach lighting applications. For 105 W, 240 VAC to 15.9 VAC applications, use transformer use Part No. 35C0095.
- For in-pavement FAA-E-2968 MALSR medium-intensity system, Style II, unidirectional green applications, use part number 44A6440-1000. This fixture uses three 62 W lamps and is photometrically equivalent to the older style 200 W L-850E fixtures that were used in this application. See data sheet 2029 for details.

2.0 Parts

To order parts, call ADB SAFEGATE Customer Service or your local representative.

2.1 ALSF/MALSR Ordering Codes

ALSF Master Control Cabinet

44D1650/

Flashers
Monitoring
Voltage
Enclosure Type

Flashers

- 1 = 8 flashers (maximum)
- 2 = 15 flashers (maximum)
- 3 = 21 flashers (maximum)

Monitoring

- 1 = Without monitoring
- 2 = With Monitoring (standard)

Voltage

- 1 = 120/240 VAC (standard)
- 2 = 480 VAC

Enclosure Type

- 1 = Standard
- 2 = Stainless steel

MALSR Master Control Cabinet

44D1655/ 1 1

Flashers
Monitoring

Flashers

- 1 = 5 flashers (maximum)
- 2 = 8 flashers (maximum)
- 3 = 11 flashers (maximum)

Monitoring

- 1 = With monitoring
- 2 = Without monitoring (standard)

Individual Control Cabinet (ICC)

44D1651/

Flasher Type

Flasher Type

- 1 = Elevated Flasher
- 3 = Elevated Flasher Panel Only
- 5 = Elevated Flasher (Stainless Steel)

Elevated Flasher

44D1677/

Slip Fit

Slip Fit

- 1 = Slip fitter for 2-inch EMT, 1.5-inch tube and tower
- 2 = Slip fitter for 1.5-inch Schedule 40 pipe and 62B0064 frangible coupling only



Note

120 W, 2000 VAC, PAR-56 Xenon lamp included. For replacement lamps, use part number 48B0022.

Spare Parts Trunk

44D1652/

Monitoring
Frequency
Flashers

Monitoring

- 1 = Flasher With Monitoring (Standard)
- 2 = Flasher Without Monitoring

Frequency

- 1 = 60 Hz

Flashers

- 1 = 8 Flashers (Maximum) System
- 2 = 15 Flashers (Maximum) System
- 3 = 21 Flashers (Maximum) System

Figure 4: MALSR Primary Control Cabinet

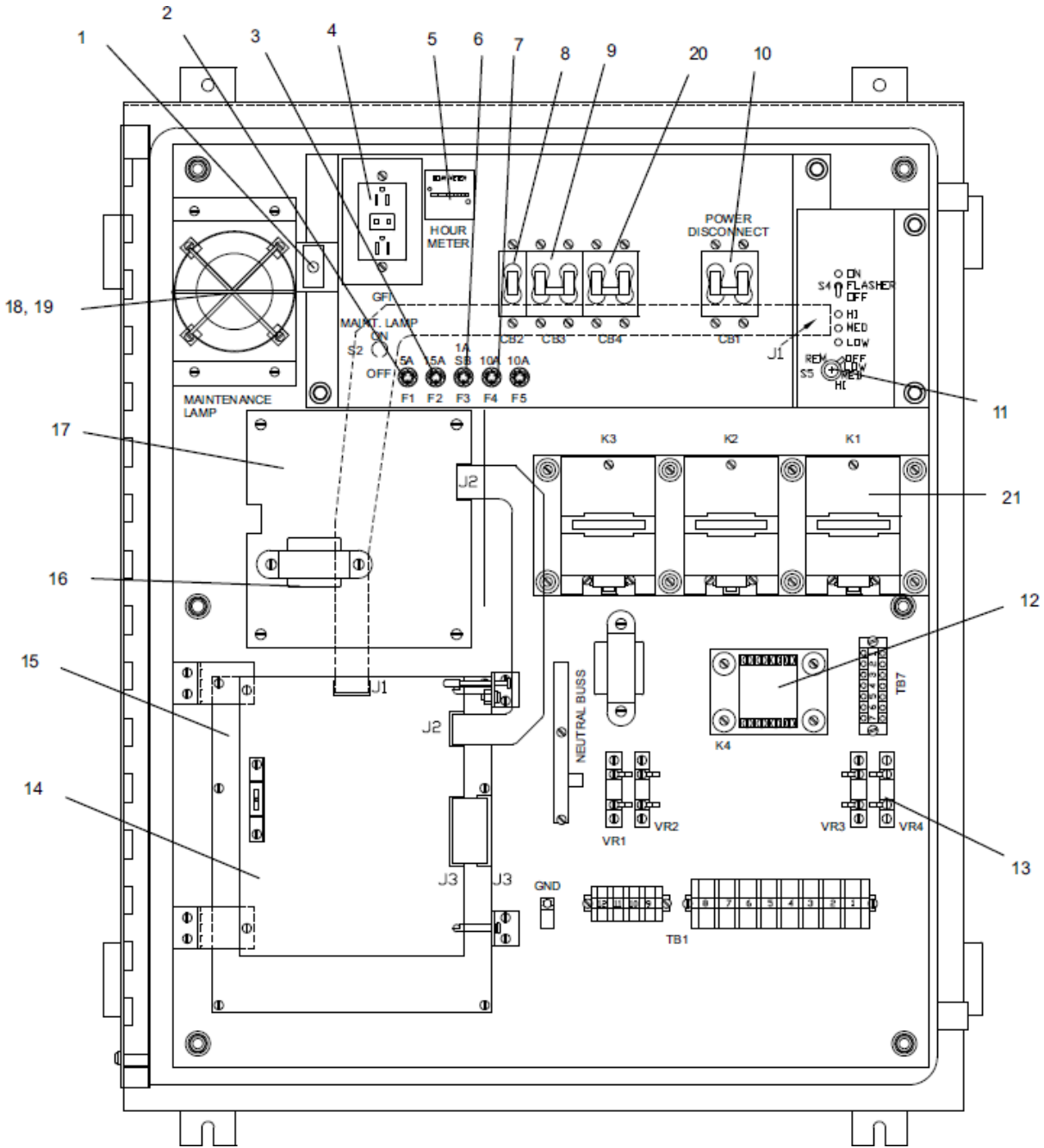

Figure 5: ALSF Primary Control Cabinet (Standard 120/240 Vac System)

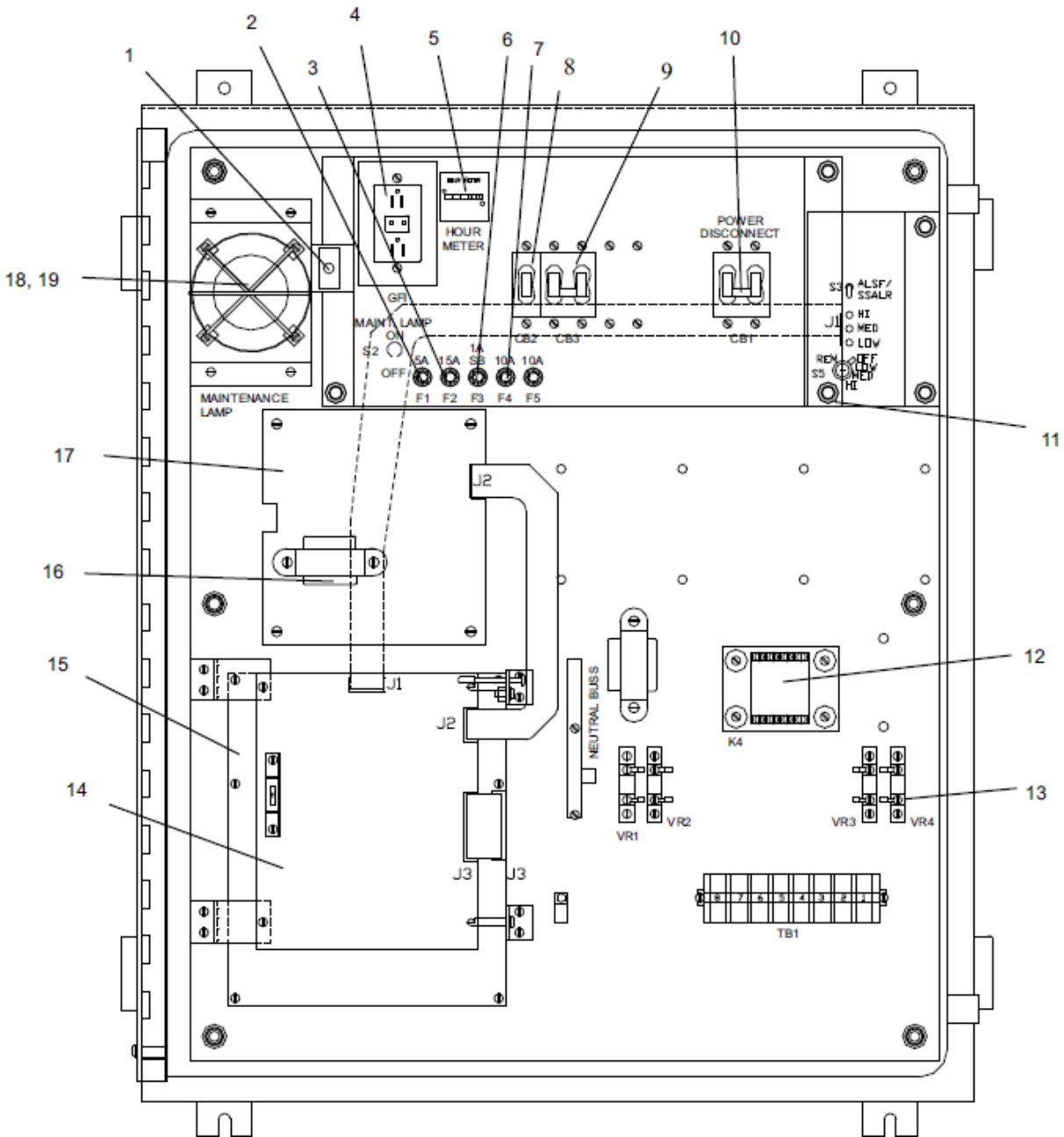
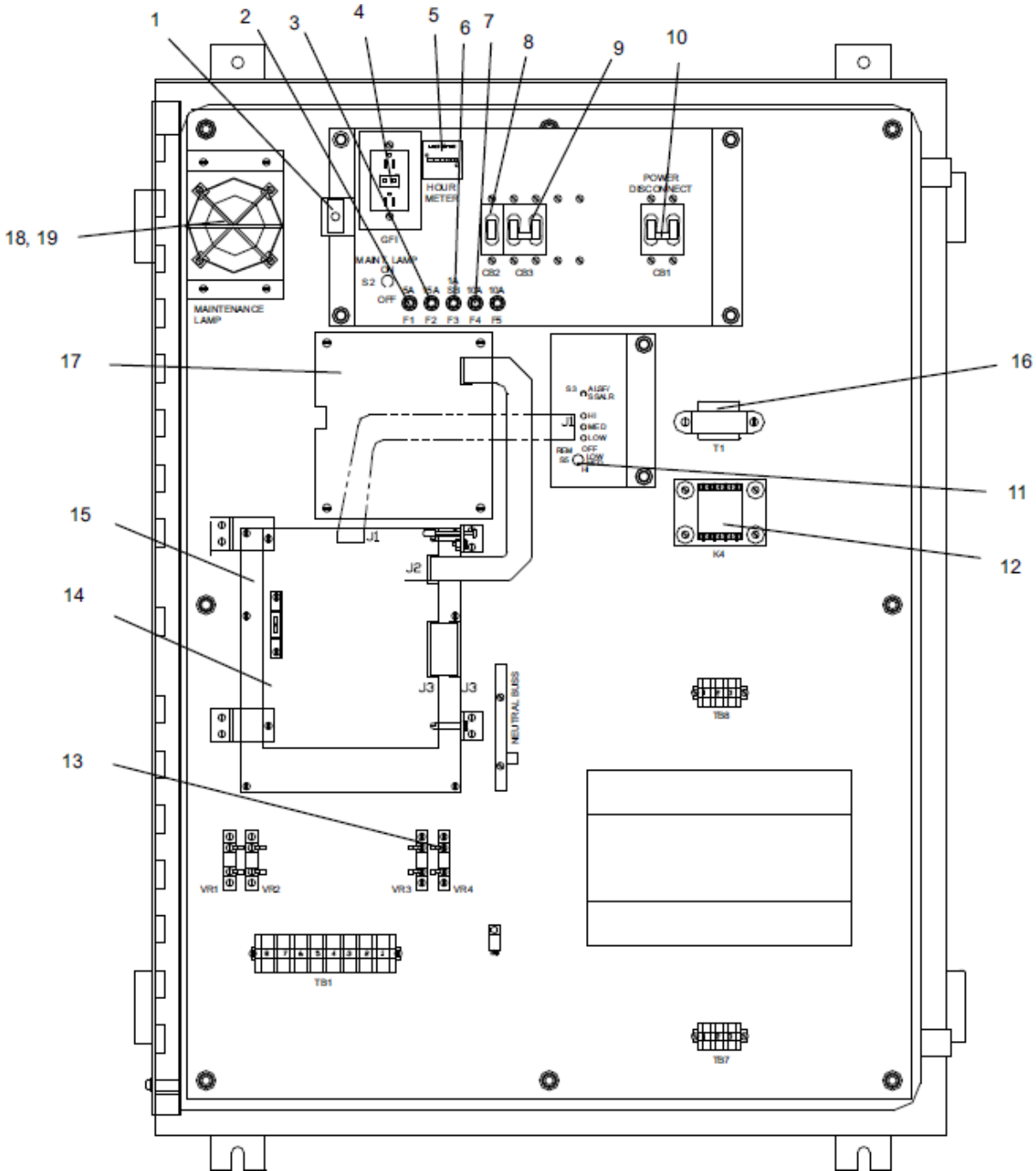

Figure 6: ALSF Primary Control Cabinet (Optional 240/480 Vac System)



2.2.2 MALSR Primary Control Cabinet Specific Parts List

See [Figure 4](#). This subsection provides primary control cabinet parts applicable only to the MALSR system.

The MALSR primary control cabinet part number is 44D1655-X.

Item	Description	Part Number	Quantity
20	Circuit breaker, 70 A (AIRPAX #219-2-1-62F-3-1-70), MALSR	57A0049	1
21	Contactors, 70 A, 120 Vac (TELEMECANIQUE #LC1- 050BK), MALSR	53A0252	3

2.2.3 Flashing Light Assembly Parts List

See [Figure 7](#). Refer to [Table 2](#) for flashing light assembly part numbers.

Table 2: Flashing Light Assembly Part Numbers

Flashing Light Assembly Type	Part Number
Uses slip fitter with 2-in. EMT, 1-1/2-in. (50.8 mm) tube and towers	44D1677/1
Uses slip fitter with 1-1/2-in. Schedule 40 pipe and 62B0064 frangible coupling	44D1677/2

Table 3: Flashing Light Assembly Part Numbers

Item	Description	Part Number	Quantity
1	Lamp clip	60B0900	3
10	Safety Interlock Switch	45A0297	1
11	Safety Interlock Switch Insulator Plate	63B0534	1



Note

Items 1, 10 and 11 are not shown.

Figure 7: Flashing Light Assembly

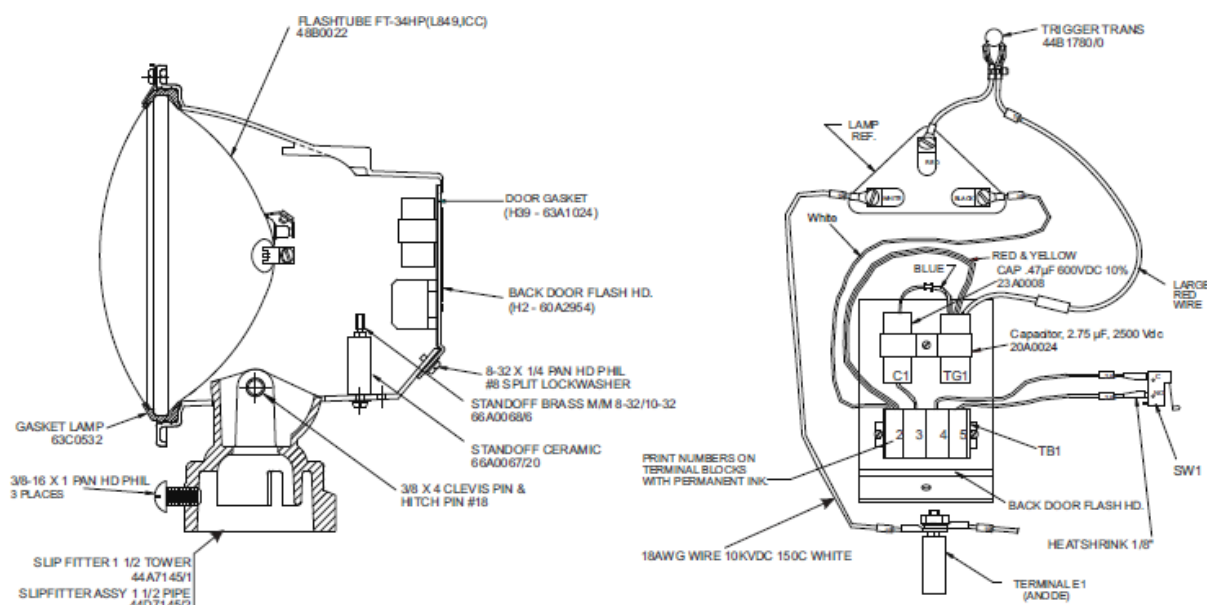

2.2.4 Individual Control Cabinet Parts List

See Figure 8 for the individual control cabinet with elevated flasher. See Figure 9 for the individual control cabinet with in-pavement flasher. Individual control cabinet part number is 44D1651-1 for the ICC with elevated flasher and 44D1651-2 for the ICC with in-pavement flasher.

Item	Description	Part Number	Quantity
16	Transformer		1
	Transformer, (for elevated flasher unit)	35C0140	
	Transformer, (for in-pavement flasher unit)	35A0569	

Figure 8: Individual Control Cabinet (Elevated Flasher Only)

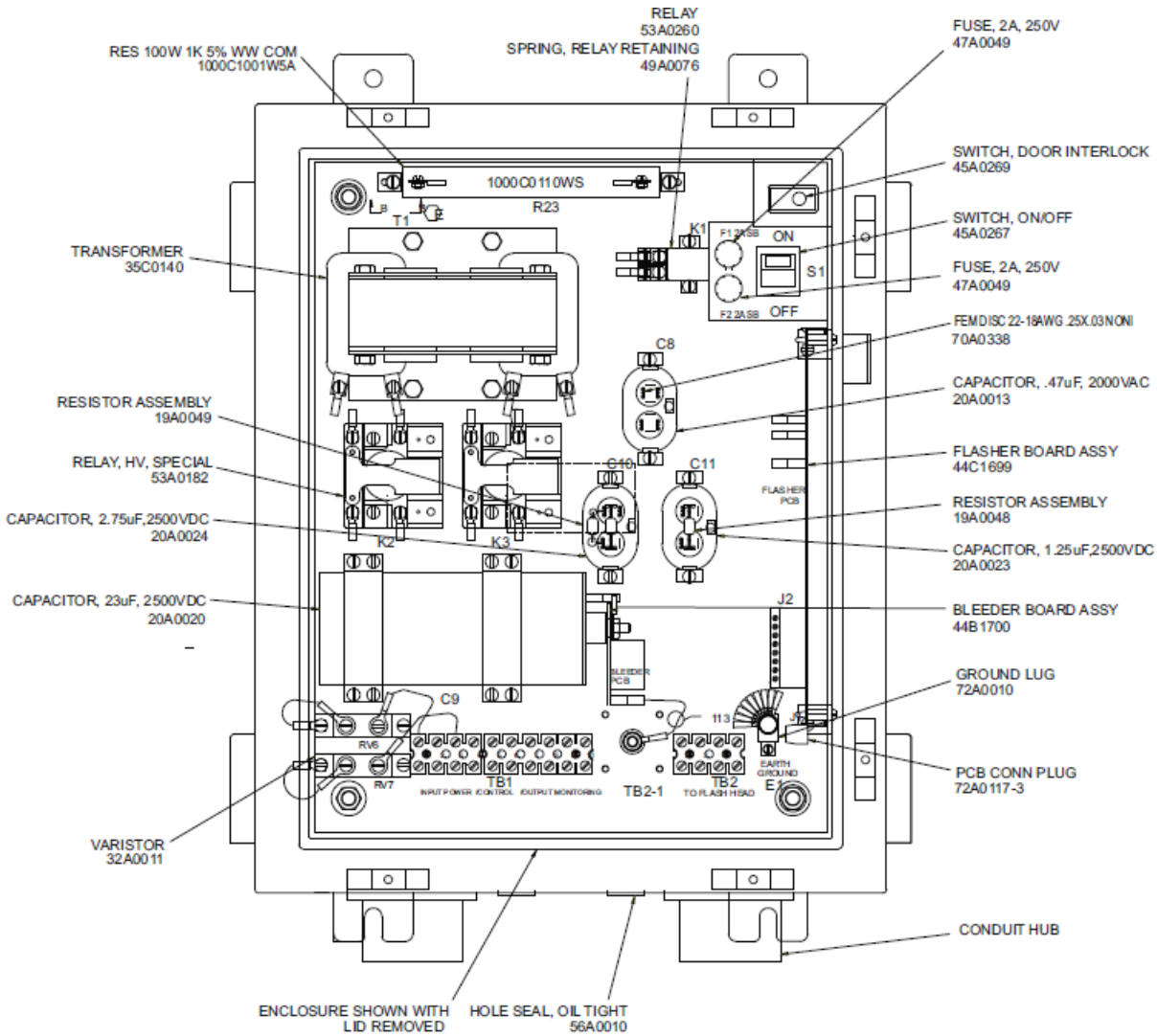

2.2.5 Steady Burning Light Assembly Parts List

Refer to instruction manual 96A0119, PAR-56 Steady-Burning Approach Light for parts list and diagrams for the steady burning light assembly.

2.2.6 MALSR PAR-38 Lampholder Assembly Parts List

See [Figure 10](#) . PAR-38 parts apply only to the MALSR system.

Item	Description	Part Number	Quantity
1	PAR38 Lamp Holder Assembly	AS00061-001-02	1
2	PAR38 Lamp Holder Silicone Seal (Spare Part)	SP00029-000-01	1 (qty 1 = 10pcs)

Figure 10: MALSR PAR-38 Lamp Holder Assembly Spare Parts

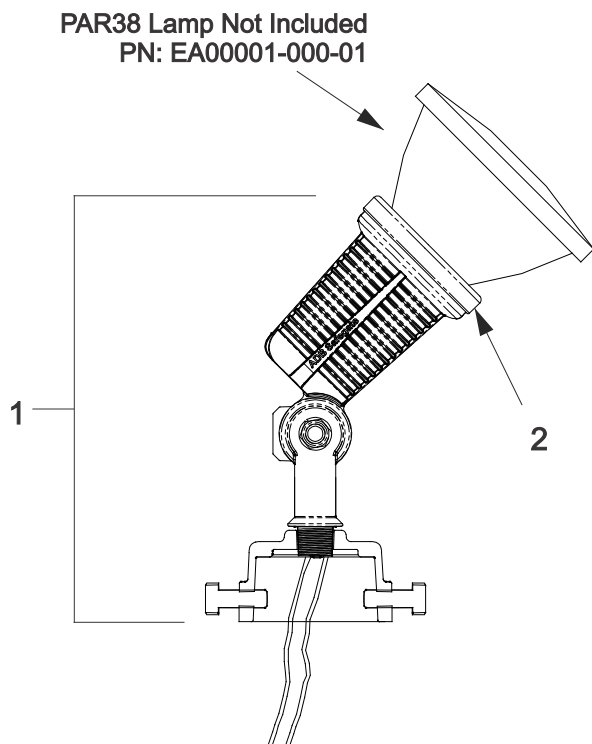

2.2.7 ALSF/MALSR In-pavement Flasher (without PCB) Parts List

See [Figure 11](#). Refer below for the in-pavement flasher without PCB parts list. The part number for the in-pavement flasher is 44A6234-1.



Note

This fixture is no longer available.



Note

The previous part number for the in-pavement flashing light was 1440.02.050.

Item	Description	Part Number	Quantity
1	Ring, cast iron	4070.93.970	1
2	Screw, #3/8-16 UNC x 7/8, stainless steel	7200.13.813	6
3	Spring, washer M10, stainless steel	7284.10.464	28
4	Cover, cast iron	4070.93.960	1
5	Lens, glass	5050.01.300	1
6	Prism strip, silicone	4070.97.150	2
7	Sealant, RTV	7835.55.150	AR
8	O-ring, 11.984 diameter, rubber	7080.90.390	1
9	Screw, #3/8-16 UNC x 7/8, stainless steel	7200.23.806	14
10	O-ring, 10.975 diameter, rubber	7080.90.380	2
11	Screw, M6 x 25, stainless steel	7100.08.576	6
12	Spring, washer, M6, stainless steel	7284.10.445	22
13	Lens holder, left, steel plated	4070.95.390	1
14	Stud, steel plated	4070.95.360	2
15	Light base, steel plated	4070.95.140	1
16	Hex nut, M10, stainless steel	7150.53.300	6
17	Flat washer, M10, stainless steel	7283.04.710	8
18	Alignment pin, stainless steel	7275.60.313	1
19	Inner cover, steel plated	4071.59.120	1
20	Cable clamp, nylon	6126.22.050	1
21	Nut for PC, brass	4070.97.130	1
22	Washer for PC, stainless steel	4070.97.130	1
23	Packing ring, PG16, rubber	6126.01.301	1
24	Sealant	7835.55.070	AR
25	Sealant	7835.45.100	AR
27	Interlock switch, stainless steel	4070.97.010	1
28	Screw, M4 x 8, stainless steel	7110.08.358	2
29	Spring washer, M4, stainless steel	7284.10.416	2
30	Box for connection, aluminum	4071.57.660	1
31	Compression gland, brass	6126.01.330	1
32	Screw, M6 x 16, stainless steel	7110.08.561	4
33	Pressure release screw, stainless steel	4070.97.040	1
34	O-ring, silicone	7080.90.016	1
35	Stud, steel plated	4070.96.531	3
36	Screw, M6 x 20, stainless steel	7100.08.569	6

Item	Description	Part Number	Quantity
37	Stud, steel plated	4070.95.351	1
38	Optical system	4070.95.351	1
40	Lens holder, right, steel plated	4070.95.390	1

Figure 11: In-pavement Flasher Assembly (without PCB) Reference Only

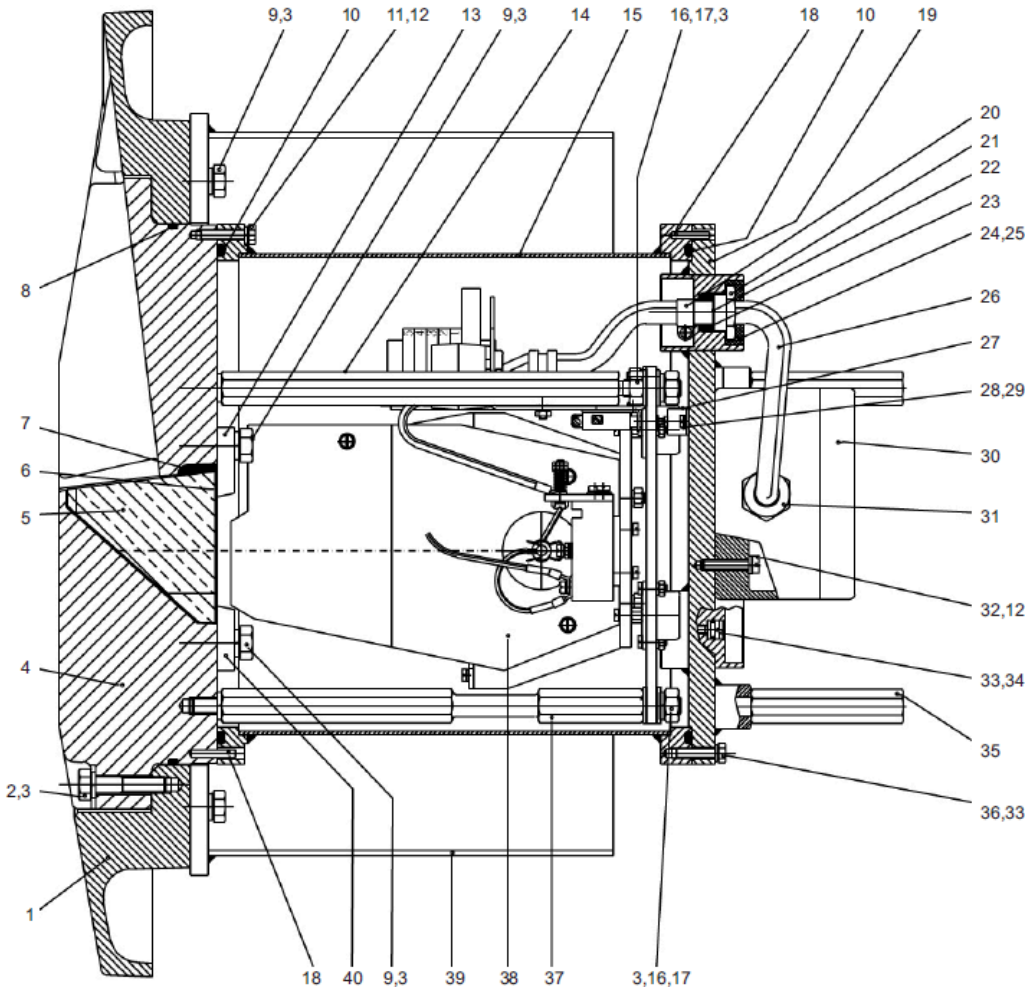

2.2.8 ALSF/MALSR In-pavement Flasher (with PCB) Parts List

See [Figure 12](#). Refer below for the in-pavement flasher with PCB parts list. The part number for the in-pavement flasher with PCB is 44A6234-2.

Item	Description	Part Number	Quantity
1	E2628 in-pavement flasher	1440.02.050	1
2	PCB assembly in-pavement rigger interface	44A6235	1
3	Screw, 6-32 x 3/8 pan head	64A0198/6	2
4	Nut, 6-32 hex	65A0015/11	2
5	Flat washer, #6	66A0015/11	2
6	Exterior lock washer, #6	66A0039/4	2
7	Standoff hex M-F 1/2 x, 6-32	66A0129/8	2
(Not shown)	Male disc, 16-14 AWG 0.25 x 6-32	70A0328	2

Figure 12: In-pavement Flasher Assembly (with PCB)

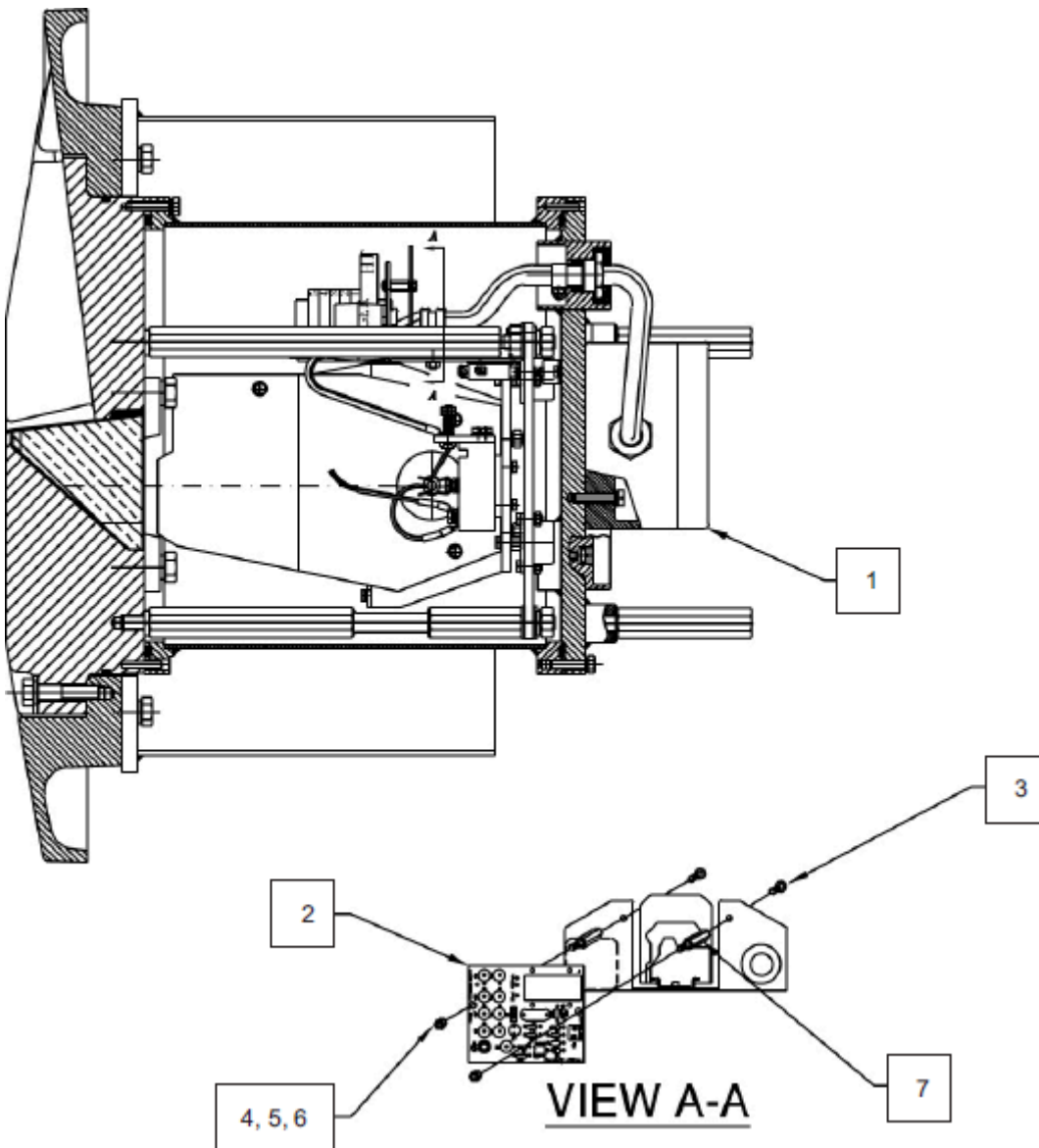

2.2.9 ALSF/MALSR In-pavement Optical Assembly Parts List

See Figure 12 through Figure 14 Refer below for the in-pavement optical assembly parts list. The part number for the optical assembly is 4071.59.180.

Item	Description	Part Number	Quantity
1	Reflector assembly	4070.97.110	1
2	Reflector clamp, stainless steel	4070.97.120	1
3	Screw, SCH M4 x 10, stainless steel	7110.08.362	17
4	Spring washer, M4, stainless steel	7284.10.416	32
5	Reflector, aluminum, left	4070.95.470	1
6	Reflector, aluminum, right	4070.95.470	1
7	Hex nut, M4, stainless steel	7150.53.180	18
8	Flat washer, M4, stainless steel	7283.04.230	16

Item	Description	Part Number	Quantity
9	Terminal block, support	4071.57.680	1
10	Blind rivets	7272.90.530	2
11	End barrier	6112.45.400	2
12	Terminal block	6112.45.420	5
13	Marker (1,2,3,4,5)	6112.45.422	5
14	Terminal block	6112.45.410	1
15	Marker (HT)	6112.45.412	1
16	Trigger transformer	1440.02.180	1
17	Cable clamp	6126.22.050	1
18	Stud, L 12 x M4 M/F	4060.65.570	1
19	Interlock switch support, stainless steel	4090.97.050	1
20	Screw #6-32 UNC ¼, stainless steel	7211.10.601	2
21	Screw #6-32 UNC ½, stainless steel	7211.10.603	1
22	Hex nut #6-32, stainless steel	7250.08.011	1
23	Interlock switch	6150.90.120	1
24	Screw M5 x 16, stainless steel	7110.08.561	4
25	Spring washer, M5, stainless steel	7284.10.426	8
26	Hex nut, M5, stainless steel	7150.53.200	4
27	Optical support, aluminum	4070.95.320	1
28	Main support, aluminum	4070.95.310	1
29	Screw SCH M4 x 16, stainless steel	7110.08.370	9
30	Lamp support	4070.97.070	2
31	Tab (6.3 - diameter 4)	6111.87.090	2
32	Helicoil M4, stainless steel	7162.08.240	8
33	Spade connector, A4-2.5	6110.12.005	2
34	Insulating flexi therm, ¼-in.	6108.75.807	
35	Insulated wire, 16 AWG, 9 kV	6103.93.010	
36	Xenon flashing tube	2990.82.650	1
37	Lampholder, brass	6130.99.370	2
38	Screw M4 x 25, stainless steel	7110.08.383	1
39	Spring D.7 x 16, stainless steel	5000.04.690	1
40	Connector, H.V., trigger wire	4070.97.090	1
41	Screw M4 x 20, stainless steel	7110.08.377	2
42	Screw M5 x 20, stainless steel	7110.08.443	4
43	Helicoil, M5, stainless steel	7162.08.250	4

Item	Description	Part Number	Quantity
44	Lamp holder	4070.97.080	2
45	Grommet	6126.20.565	1
46	Reflector holder, stainless steel	4070.95.680	1
47	Shock absorber	7030.00.010	3
48	End plate for terminal block	6112.45.421	1
49	End plate for terminal block	6112.45.411	1

Figure 13: In-pavement Flasher Optical Assembly (Side View)

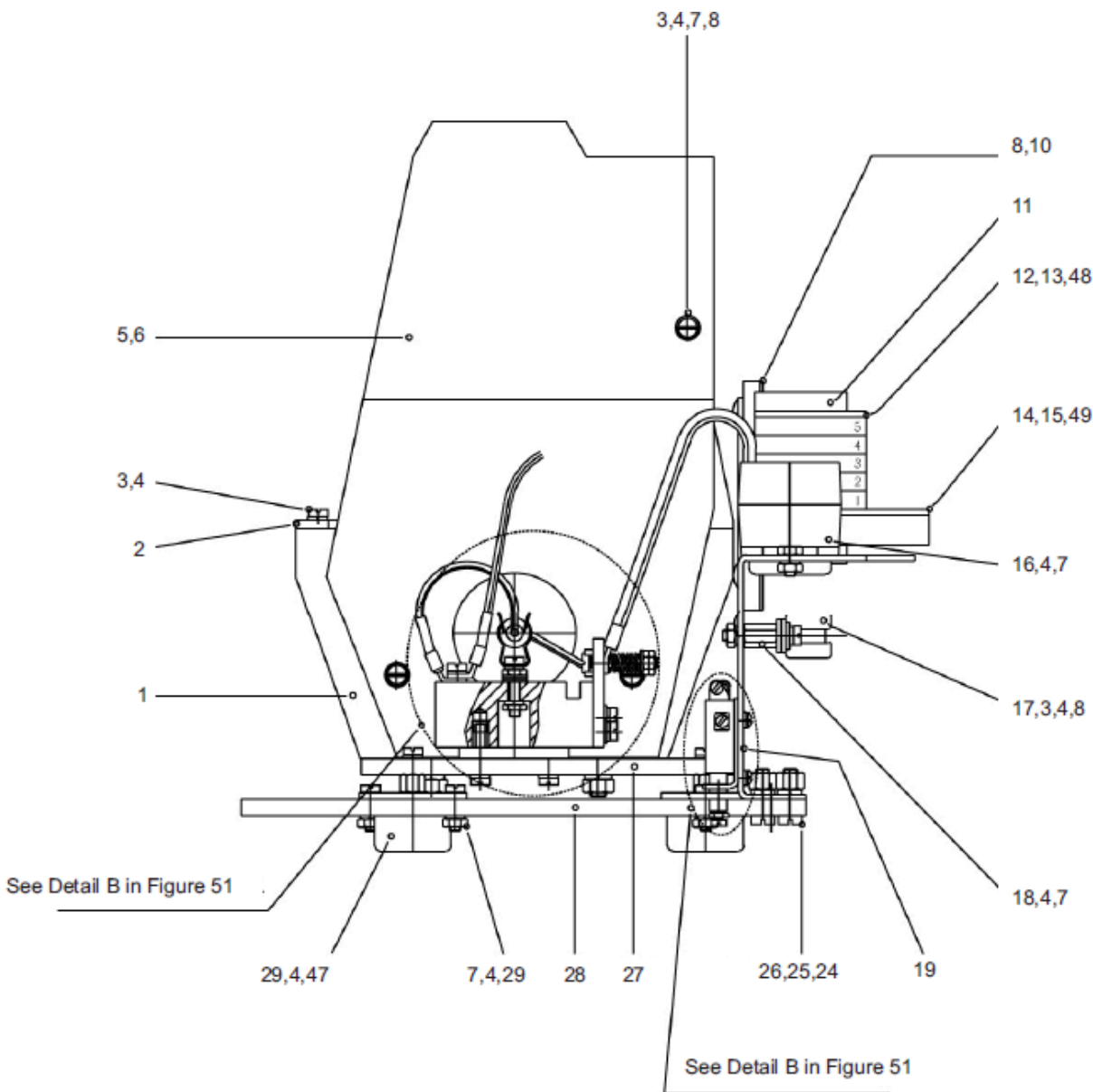

Figure 14: In-pavement Flasher Optical Assembly (Detail A and Detail B)

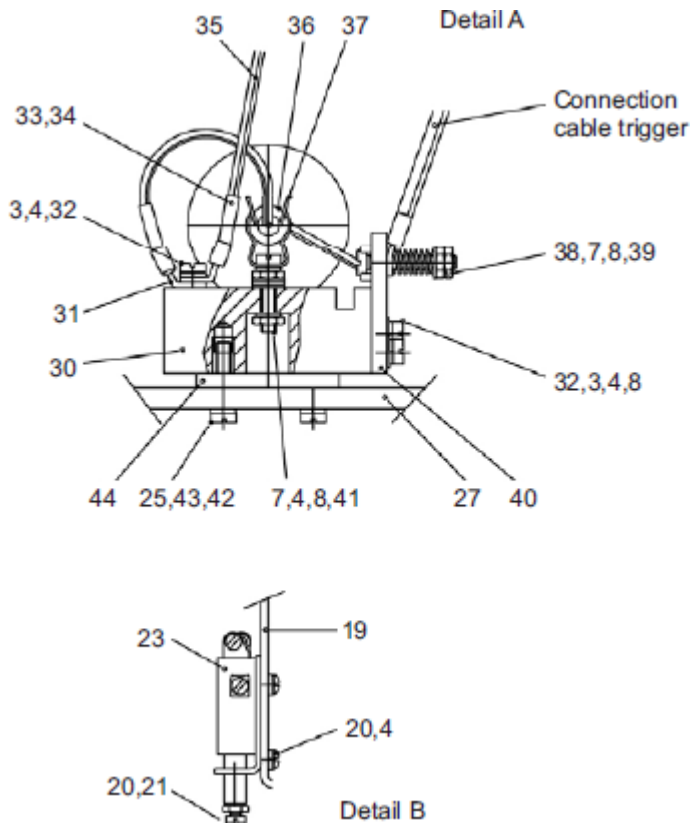
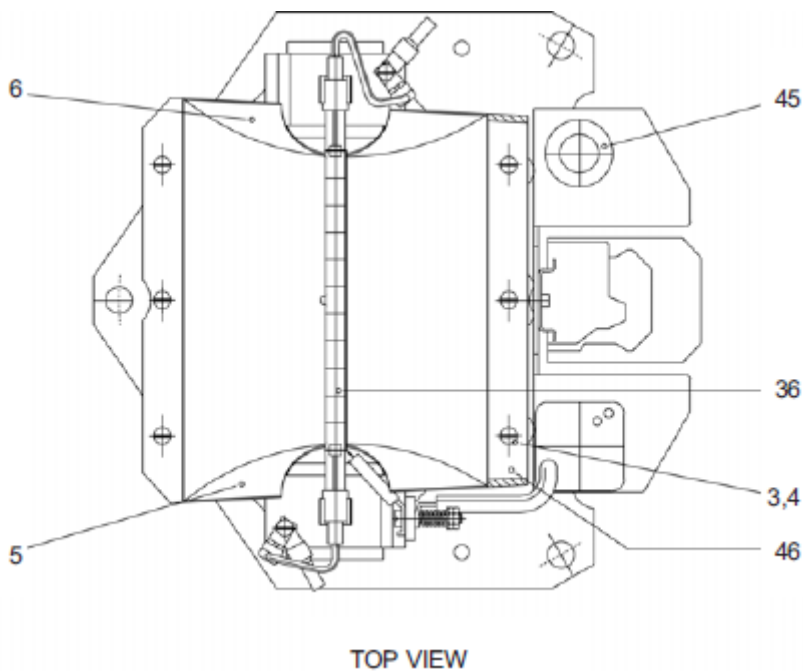

Figure 15: In-pavement Flasher Optical Assembly (Top View)



2.2.10 Optional Parts

See [Figure 38](#). Refer below for optional parts.

Item	Description	Part Number	Quantity
26	6-core cable	6104.90.206FT	AR
Not shown	Connector kit, in-pavement flasher, male plug	70A0618	1
Not shown	Connector kit, in-pavement flasher, female receptacle	70A0619	1

2.2.11 Separate Line Item Optional Parts

This subsection provides separate optional line items.

Item	Description	Part Number	Quantity
Not shown	Flasher tester (Type FLT)	44D1686/1	
Not shown	Frangible coupling (Type EMT)	44B0180	1
	Frangible coupling (Type F2)	62B0064	1
Not shown	High voltage wire, AWG 12, 3 kV	89A0110/1	AR
Not shown	Lamps, PAR-38, 60 W, 120 Vac, standard, for MALSR only	EA00001-000-01	1
	Lamps, PAR-56, 300 W, 120 Vac	48A0118	1
	Lamps, PAR-56, 200 W, 6.6 A	48A0094	1
	Lamps, PAR-56, 300 W, 20 A	48A0091	1
	Lamps, PAR-56, 500 W, 20 A	48A0092	1
Not shown	Power transformer, 15 kVA (Type T15) for MALSR only	44D1685/1	1
39	LB-4 deep base	Contact ADB Safegate	1

2.2.12 Separate Line Items Required Parts List

This subsection provides parts for separate line items that are required but not included with the ALSF/MALSR system.

Item	Description	Part Number	Quantity
Not shown	Junction box assembly	44D1653	1
Not shown	Aiming device kit		
	Aiming device, MALSR/ALSF	4D1654	1
	Aiming device (for MALSR PAR-56 lamps only)	44D1654/1	1
	Aiming device (for MALSR PAR-56 and PAR-38 lamps)	44D1654/2	1
Not shown	Spare parts trunk, for ALSF only	44D1652	1
Not shown	Power transformer, 15 kVA, MALSR only	44D1685/1	1

2.2.13 Recommended Spare Parts

This subsection provides recommended spare parts for the primary control cabinet, flashing light assembly, individual control cabinet, in-pavement flasher final assembly, and in-pavement flasher optical assembly.



Note

This spare parts list assumes the spare parts trunk is already available.

2.2.13.1 Primary Control Cabinet Spare Parts

See [Figure 4](#) through [Figure 6](#). Refer below for Primary Control Cabinet spare parts.

Item	Description	Part Number
2	Fuse, 5A (BUSS AGC-5)	47A0015
3	Fuse, 15 A (BUSS AGC-15)	47A0016
6	Fuse, 1 A, S.B. (BUSS MDL-1)	47A0017
7	Fuse, 10 A (BUSS AGC-10)	47A0018
12	Varistor	32A0011

2.2.13.2 Flashing Light Assembly Spare Parts

See [Figure 7](#). Refer below for flashing light assembly spare parts.

Item	Description	Part Number
2	Flash lamp	48B0022
7	Trigger transformer assembly	44B1780/1

2.2.13.3 Individual Control Cabinet Spare Parts

See [Figure 8](#). Refer below for Individual Control Cabinet spare parts.

Item	Description	Part Number
3	Relay	53A0260
	Relay, DPDT, 120 Vac, 15 A at 277 Vac, ALSF only	53A0183
	Relay, DPDT, 120 Vac, 15 A at 277 Vac, MALSR only	
4	Fuse, 2 A, 250 V, SLO-BLO (BUSS MDA-2)	47A0049
15	Relay, DPDT, coil, 120 Vac	53A0182

2.2.13.4 In-pavement Flasher Spare Parts

See [Figure 11](#). Refer below for in-pavement flasher final assembly spare parts.

Item	Description	Part Number
5	Lens, glass	5050.01.300
7	Sealant, RTV	7835.55.150
8	O-ring, 11.984 diameter, rubber	7080.90.390
10	O-ring, 10.975 diameter, rubber	7080.90.380

2.2.13.5 In-pavement Flasher Optical Assembly Spare Parts

See [Figure 12](#) through [Figure 14](#). Refer below for in-pavement flasher optical assembly spare parts.

Item	Description	Part Number
16	Trigger transformer	1440.02.180
23	Interlock switch, MS16106-1	6150.90.120
36	Xenon flashing tube, P4070.97.140.E	2990.82.650

Appendix A: SUPPORT

Our experienced engineers are available for support and service at all times, 24 hour/7 days a week. They are part of a dynamic organization making sure the entire ADB SAFEGATE is committed to minimal disturbance for airport operations.

ADB SAFEGATE Support

Technical Support – Global

Customers in Europe, the Middle East, Africa or Asia Pacific are more than welcome to our portal for technical support. Trained in all areas of system issues, troubleshooting, quality control and technical assistance, our highly experienced Technical support specialists are available 24 hours a day, seven days a week to provide assistance over the phone. In the Americas, we also offer live technical support.

Live Technical Support – Americas

If at any time you have a question or concern about your product, contact ADB SAFEGATE's US-based technical support specialists, available 24 hours a day, seven days a week, to assist you via phone.

ADB SAFEGATE Americas Technical Service & Support (US & Canada) :+1-800-545-4157

ADB SAFEGATE Americas Technical Service & Support (Canada): +1-905-631-1597

ADB SAFEGATE Americas Technical Service & Support (International): +1-614-861-1304

We can also be reached via email during regular business hours:

Airfield and Gate: techservice.us@adbsafegate.com

Gate: gateservice.us@adbsafegate.com

We look forward to working with you!

Before You Call

When you have an airfield lighting or system control system problem, prior to calling, please ensure the following:

- Review the product's manual and troubleshooting guide.
- Be located with the product ready to troubleshoot.
- Have all necessary information available: airport code/company name, customer id number, contact phone number/email address, product/part number.
- Have a True RMS meter available and any other necessary tools.

When calling about an issue with Safedock A-VDGS, we can serve you better if you collect the following information before you call:

- Relevant information regarding the issue you are calling about, such as gate number, flight number, aircraft type and time of the event.
- What, if any, actions have been taken to resolve the issue prior to the call.
- If available, provide a CCTV recording of the incident to aid in aligning the information from the Safedock log file.



Note

For more information, see www.adbsafegate.com, contact ADB SAFEGATE Support via email at support@adbsafegate.com or Europe: +32 2 722 17 11

Americas: +1 614 861 1304. Press 3 for technical service or press 4 for sales support.

China: +86 (10) 8476 0106

Middle East and Africa: +971 4 452 7575

A.1 ADB SAFEGATE Website

The ADB SAFEGATE website, www.adbsafegate.com, offers information regarding our airport solutions, products, company, news, links, downloads, references, contacts and more.

A.2 Recycling

A.2.1 Local Authority Recycling

The disposal of ADB SAFEGATE products is to be made at an applicable collection point for the recycling of electrical and electronic equipment. The correct disposal of equipment prevents any potential negative consequences for the environment and human health, which could otherwise be caused by inappropriate waste handling. The recycling of materials helps to conserve natural resources. For more detailed information about recycling of products, contact your local authority city office.

A.2.2 ADB SAFEGATE Recycling

ADB SAFEGATE is fully committed to environmentally-conscious manufacturing with strict monitoring of our own processes as well as supplier components and sub-contractor operations. ADB SAFEGATE offers a recycling program for our products to all customers worldwide, whether or not the products were sold within the European Union (EU).

ADB SAFEGATE products and/or specific electrical and electronic component parts which are fully removed/separated from any customer equipment and returned will be accepted for our recycling program.

All items returned must be clearly labeled as follows:

- For Restriction of Hazardous Substances (RoHS)/Waste Electrical and Electronic Equipment (WEEE) Recycling
- Sender contact information (Name, Business Address, Phone number).
- Main Unit Serial Number.

ADB SAFEGATE will continue to monitor and update according for any future requirements for EU directives as and when EU member states implement new regulations and or amendments. It is our aim to maintain our compliance plan and assist our customers.

WWW.ADBSAFEGATE.COM

Empowering the Airside Evolution

SMARTER. BETTER. NOW.

