



LINC 360

Controller

User Manual

96A0480, Rev. K, 2025/08/18



A.0 Disclaimer / Standard Warranty

CE certification

The equipment listed as CE certified means that the product complies with the essential requirements concerning safety and hygiene. The European directives that have been taken into consideration in the design are available on written request to ADB SAFEGATE.

ETL certification

The equipment listed as ETL certified means that the product complies with the essential requirements concerning safety and C22.2 No.180:13 (R2018) regulations. The CSA directives that have been taken into consideration in the design are available on written request to ADB SAFEGATE.

All Products Guarantee

ADB SAFEGATE will correct by repair or replacement per the applicable guarantee below, at its option, equipment or parts which fail because of mechanical, electrical or physical defects, provided that the goods have been properly handled and stored prior to installation, properly installed and properly operated after installation, and provided further that Buyer gives ADB SAFEGATE written notice of such defects after delivery of the goods to Buyer. Refer to the Safety section for more information on Material Handling Precautions and Storage precautions that must be followed.

ADB SAFEGATE reserves the right to examine goods upon which a claim is made. Said goods must be presented in the same condition as when the defect therein was discovered. ADB SAFEGATE further reserves the right to require the return of such goods to establish any claim.

ADB SAFEGATE's obligation under this guarantee is limited to making repair or replacement within a reasonable time after receipt of such written notice and does not include any other costs such as the cost of removal of defective part, installation of repaired product, labor or consequential damages of any kind, the exclusive remedy being to require such new parts to be furnished.

ADB SAFEGATE's liability under no circumstances will exceed the contract price of goods claimed to be defective. Any returns under this guarantee are to be on a transportation charges prepaid basis. For products not manufactured by, but sold by ADB SAFEGATE, warranty is limited to that extended by the original manufacturer. This is ADB SAFEGATE's sole guarantee and warranty with respect to the goods; there are no express warranties or warranties of fitness for any particular purpose or any implied warranties of fitness for any particular purpose or any implied warranties other than those made expressly herein. All such warranties being expressly disclaimed.

Standard Products Guarantee

Products manufactured by ADB SAFEGATE are guaranteed against mechanical, electrical, and physical defects (excluding lamps) which may occur during proper and normal use for a period of two years from the date of ex-works delivery, and are guaranteed to be merchantable and fit for the ordinary purposes for which such products are made.



Note

See your applicable sales agreement for a complete warranty description.

Replaced or repaired equipment under warranty falls into the warranty of the original delivery. No new warranty period is started for these replaced or repaired products.

FAA Certified products manufactured by ADB SAFEGATE

ADB SAFEGATE L858 Airfield Guidance Signs are warranted against mechanical and physical defects in design or manufacture for a period of 2 years from date of installation, per FAA AC 150/5345-44 (applicable edition).

ADB SAFEGATE LED products (with the exception of obstruction lighting) are warranted against electrical defects in design or manufacture of the LED or LED specific circuitry for a period of 4 years from date of installation, per FAA EB67 (applicable edition). These FAA certified constant current (series) powered LED products must be installed, interfaced and powered with and through products certified under the FAA Airfield Lighting Equipment Program (ALECP) to be included in this 4 (four) year warranty. This includes, but is not limited to, interface with products such as Base Cans, Isolation Transformers, Connectors, Wiring, and Constant Current Regulators.



Note

See your sales order contract for a complete warranty description.

Replaced or repaired equipment under warranty falls into the warranty of the original delivery. No new warranty period is started for these replaced or repaired products.

Liability



WARNING

Use of the equipment in ways other than described in the catalog leaflet and the manual may result in personal injury, death, or property and equipment damage. Use this equipment only as described in the manual.

ADB SAFEGATE cannot be held responsible for injuries or damages resulting from non-standard, unintended uses of its equipment. The equipment is designed and intended only for the purpose described in the manual. Uses not described in the manual are considered unintended uses and may result in serious personal injury, death or property damage.

Unintended uses, includes the following actions:

- Making changes to equipment that have not been recommended or described in this manual or using parts that are not genuine ADB SAFEGATE replacement parts or accessories.
- Failing to make sure that auxiliary equipment complies with approval agency requirements, local codes, and all applicable safety standards if not in contradiction with the general rules.
- Using materials or auxiliary equipment that are inappropriate or incompatible with your ADB SAFEGATE equipment.
- Allowing unskilled personnel to perform any task on or with the equipment.

Copyright Statement

This manual or parts thereof may not be reproduced, stored in a retrieval system, or transmitted, in any form or by any means, electronic, mechanical, photocopying, recording, nor otherwise, without the author's prior written consent.

This manual could contain technical inaccuracies or typographical errors. The author reserves the right to revise this manual from time to time in the contents thereof without obligation of the author to notify any person of such revision or change. Details and values given in this manual are average values and have been compiled with care. They are not binding, however, and the author disclaims any liability for damages or detriments suffered as a result of reliance on the information given herein or the use of products, processes or equipment to which this manual refers. No warranty is made that the use of the information or of the products, processes or equipment to which this manual refers will not infringe any third party's patents or rights. The information given does not release the buyer from making their own experiments and tests.

Table of Contents

1.0 Safety	1
1.1 Safety Messages.....	1
1.1.1 Introduction to Safety.....	2
1.1.2 Intended Use.....	2
1.1.3 Operation Safety.....	3
1.1.4 Maintenance Safety.....	3
1.1.5 Material Handling Precautions, ESD.....	4
1.1.6 Arc Flash and Electric Shock Hazard.....	4
2.0 LINC 360Controller	5
2.1 Manual Introduction.....	5
2.1.1 How to work with the manual.....	5
2.2 LINC 360Controller Introduction.....	5
2.2.1 Individual Lamp Control & Monitoring System (ILCMS).....	5
2.2.2 Illustration.....	11
2.2.3 LINC 360 Technology.....	11
2.2.4 Terms.....	11
2.3 Checking the Device.....	12
2.3.1 Scope of Supply.....	12
2.3.2 Unpacking.....	12
2.3.3 Inspection.....	12
2.4 Storage.....	13
2.5 Views of the Device.....	14
2.5.1 Front View with Control Unit.....	14
2.5.2 Rear View with Connections.....	15
2.6 Theory of Operation.....	16
2.6.1 Main Characteristics and Figures.....	16
2.6.2 Integrated System Control.....	16
2.6.3 Architecture.....	17
2.7 Modes of Operation.....	18
2.7.1 State on Delivery.....	18
2.7.2 HMI Display Screen.....	18
2.7.3 Status Screen.....	18
2.7.4 Indicators Screen.....	19
2.7.5 Alarms Screen.....	20
2.7.6 Alarms History Screen.....	21
2.7.7 Block Screen.....	22
2.7.8 About Screen.....	24
3.0 Installation of stand-alone LINC 360Controllers	27
3.1 Installation in the Control Cabinet.....	27
3.1.1 Power Supply.....	27
3.1.2 Connection to the Series Circuit.....	27
3.2 Installation on a Wall.....	28
3.3 Connection to the Ethernet Network.....	28
3.4 Earth Grounding.....	29
3.5 Safety Instructions.....	29
4.0 Connection of LINC 360 to the Airside Cloud	31
4.1 Step-by-Step Instructions.....	33
5.0 Replacing a stand-alone LINC 360Controller	35
5.1 Wiring Diagram.....	36
6.0 Parts	37
6.1 Spare Components.....	37
A.0 SUPPORT	39
A.1 ADB SAFEGATE Website.....	39
A.2 Recycling.....	40
A.2.1 Local Authority Recycling.....	40
A.2.2 ADB SAFEGATE Recycling.....	40

List of Figures

Figure 1: LINC 360 Controller front view	11
Figure 2: LINC 360 Controller front view (uncovered).....	11
Figure 3: Nameplate of the LINC360 Controller	13
Figure 4: Front view with Control Unit of the LINC 360 Controller.....	14
Figure 5: Front panel of the Control Unit of the LINC 360 Controller	14
Figure 6: Rear view of the LINC 360 Controller	15
Figure 7: Typical LINC 360 Topology	16
Figure 8: Series Circuit Controller/ Fixture Architecture	17
Figure 9: Status screen. Right: Status screen when no current is detected by the controller.	19
Figure 10: Indicators screen. Right: Different colors for every state, only one active at a time.....	19
Figure 11: Indicators with warnings.....	20
Figure 12: Indicators with Alarms and Warnings. Left: Indicators with Monitoring Client	20
Figure 13: Left: Indicators with Alarms. Right: Indicators with Circuit Alarms.....	20
Figure 14: Alarm screen.....	21
Figure 15: Alarms history screen.....	21
Figure 16: Block Screen.....	22
Figure 16: Blocks screen while in local control.....	22
Figure 18: Blocks scroll of list.....	23
Figure 19: Blocks changing intensity.....	24
Figure 20: Blocks changing color	24
Figure 21: About screen.....	25
Figure 22: Rack controller diagram	27
Figure 23: Wall mount diagrams	28
Figure 24: Ethernet connections	28
Figure 25: Cloud Connection Options.....	31
Figure 26: Wiring Diagram.....	36

List of Tables

Table 1: Ordering Code: Controllers	10
Table 2: Ordering Code: Remotes	11
Table 3: Terms.....	12
Table 4: Ordering Code: Controllers	37
Table 5: Ordering Code: Remotes	37
Table 6: Ordering Code: Spare Parts	37

1.0 Safety

Introduction to Safety

This section contains general safety instructions for installing and using ADB SAFEGATE equipment. Some safety instructions may not apply to the equipment in this manual. Task- and equipment-specific warnings are included in other sections of this manual where appropriate.

1.1 Safety Messages

HAZARD Icons used in this manual

For all HAZARD symbols in use, see the Safety section. All symbols must comply with ISO and ANSI standards.

Carefully read and observe all safety instructions in this manual, which alert you to safety hazards and conditions that may result in personal injury, death or property and equipment damage and are accompanied by the symbols shown below.

	<p>WARNING Failure to observe a warning may result in personal injury, death or equipment damage.</p>
	<p>DANGER – Risk of electrical shock or ARC FLASH Disconnect equipment from line voltage. Failure to observe this warning may result in personal injury, death, or equipment damage. ARC Flash may cause blindness, severe burns or death.</p>
	<p>WARNING – Wear personal protective equipment Failure to observe may result in serious injury.</p>
	<p>WARNING – Do not touch Failure to observe this warning may result in personal injury, death, or equipment damage.</p>
	<p>CAUTION Failure to observe a caution may result in equipment damage.</p>
	<p>ELECTROSTATIC SENSITIVE DEVICES This equipment may contain electrostatic devices.</p>

Qualified Personnel

	<p>Important Information The term qualified personnel is defined here as individuals who thoroughly understand the equipment and its safe operation, maintenance and repair. Qualified personnel are physically capable of performing the required tasks, familiar with all relevant safety rules and regulations and have been trained to safely install, operate, maintain and repair the equipment. It is the responsibility of the company operating this equipment to ensure that its personnel meet these requirements. Always use required personal protective equipment (PPE) and follow safe electrical work practice.</p>
--	--

1.1.1 Introduction to Safety



CAUTION

Unsafe Equipment Use

This equipment may contain electrostatic devices, hazardous voltages and sharp edges on components

- Read installation instructions in their entirety before starting installation.
- Become familiar with the general safety instructions in this section of the manual before installing, operating, maintaining or repairing this equipment.
- Read and carefully follow the instructions throughout this manual for performing specific tasks and working with specific equipment.
- Make this manual available to personnel installing, operating, maintaining or repairing this equipment.
- Follow all applicable safety procedures required by your company, industry standards and government or other regulatory agencies.
- Install all electrical connections to local code.
- Use only electrical wire of sufficient gauge and insulation to handle the rated current demand. All wiring must meet local codes.
- Route electrical wiring along a protected path. Make sure they will not be damaged by moving equipment.
- Protect components from damage, wear, and harsh environment conditions.
- Allow ample room for maintenance, panel accessibility, and cover removal.
- Protect equipment with safety devices as specified by applicable safety regulations
- If safety devices must be removed for installation, install them immediately after the work is completed and check them for proper functioning prior to returning power to the circuit.

Failure to follow these instructions can result in serious injury, death or equipment damage

Additional Reference Materials



Important Information

- IEC – International Standards and Conformity Assessment for all electrical, electronic and related technologies.
- IEC 60364 – Electrical Installations in Buildings.
- CSA – C22.2 No.180:13 (R2018), series isolating transformers for airport lighting.
- FAA Advisory: AC 150/5340-26 (current edition), Maintenance of Airport Visual Aid Facilities.
- Maintenance personnel must refer to the maintenance procedure described in the ICAO Airport Services Manual, Part 9.
- ANSI/NFPA 79, Electrical Standards for Metalworking Machine Tools.
- National and local electrical codes and standards.

1.1.2 Intended Use



CAUTION

Use this equipment as intended by the manufacturer

This equipment is designed to perform a specific function, do not use this equipment for other purposes

- Using this equipment in ways other than described in this manual may result in personal injury, death or property and equipment damage. Use this equipment only as described in this manual.

Failure to follow this instruction can result in serious injury or equipment damage

1.1.3 Operation Safety



CAUTION

Improper Operation

Do Not Operate this equipment other than as specified by the manufacturer

- Only qualified personnel, physically capable of operating the equipment and with no impairments in their judgment or reaction times, should operate this equipment.
- Read all system component manuals before operating this equipment. A thorough understanding of system components and their operation will help you operate the system safely and efficiently.
- Before starting this equipment, check all safety interlocks, fire-detection systems, and protective devices such as panels and covers. Make sure all devices are fully functional. Do not operate the system if these devices are not working properly. Do not deactivate or bypass automatic safety interlocks or locked-out electrical disconnects or pneumatic valves.
- Protect equipment with safety devices as specified by applicable safety regulations.
- If safety devices must be removed for installation, install them immediately after the work is completed and check them for proper functioning.
- Route electrical wiring along a protected path. Make sure they will not be damaged by moving equipment.
- Never operate equipment with a known malfunction.
- Do not attempt to operate or service electrical equipment if standing water is present.
- Use this equipment only in the environments for which it is rated. Do not operate this equipment in humid, flammable, or explosive environments unless it has been rated for safe operation in these environments.
- Never touch exposed electrical connections on equipment while the power is ON.

Failure to follow these instructions can result in serious injury, death or equipment damage.

1.1.4 Maintenance Safety



DANGER

ELECTRIC SHOCK HAZARD

THIS EQUIPMENT MAY CONTAIN ELECTROSTATIC DEVICES

- DO NOT OPERATE A SYSTEM THAT CONTAINS MALFUNCTIONING COMPONENTS. IF A COMPONENT MALFUNCTIONS, TURN THE SYSTEM OFF IMMEDIATELY.
- DISCONNECT AND LOCK OUT ELECTRICAL POWER.
- ALLOW ONLY QUALIFIED PERSONNEL TO MAKE REPAIRS OR REPLACE MALFUNCTIONING COMPONENTS ACCORDING TO INSTRUCTIONS PROVIDED IN MANUAL.

FAILURE TO FOLLOW THESE INSTRUCTIONS CAN RESULT IN DEATH OR EQUIPMENT DAMAGE

1.1.5 Material Handling Precautions, ESD



CAUTION

Electrostatic Sensitive Devices

This equipment may contain electrostatic devices

- Protect from electrostatic discharge.
- Electronic modules and components should be touched only when this is unavoidable e.g. soldering, replacement.
- Before touching any component of the cabinet you shall bring your body to the same potential as the cabinet by touching a conductive earthed part of the cabinet.
- Electronic modules or components must not be brought in contact with highly insulating materials such as plastic sheets, synthetic fiber clothing. They must be laid down on conductive surfaces.
- The tip of the soldering iron must be grounded.
- Electronic modules and components must be stored and transported in conductive packing.

Failure to follow this instruction can result in equipment damage

1.1.6 Arc Flash and Electric Shock Hazard



DANGER

SERIES CIRCUITS HAVE HAZARDOUS VOLTAGES

THIS EQUIPMENT PRODUCES HIGH VOLTAGES TO MAINTAIN THE SPECIFIED CURRENT - DO NOT DISCONNECT WHILE ENERGIZED.

- ALLOW ONLY QUALIFIED PERSONNEL TO PERFORM MAINTENANCE, TROUBLESHOOTING, AND REPAIR TASKS.
- ONLY PERSONS WHO ARE PROPERLY TRAINED AND FAMILIAR WITH ADB SAFEGATE EQUIPMENT ARE PERMITTED TO SERVICE THIS EQUIPMENT.
- AN OPEN AIRFIELD CURRENT CIRCUIT IS CAPABLE OF GENERATING >5000 VAC AND MAY APPEAR OFF TO A METER.
- NEVER UNPLUG A DEVICE FROM A CONSTANT CURRENT CIRCUIT WHILE IT IS OPERATING; ARC FLASH MAY RESULT.
- DISCONNECT AND LOCK OUT ELECTRICAL POWER.
- ALWAYS USE SAFETY DEVICES WHEN WORKING ON THIS EQUIPMENT.
- FOLLOW THE RECOMMENDED MAINTENANCE PROCEDURES IN THE PRODUCT MANUALS.
- DO NOT SERVICE OR ADJUST ANY EQUIPMENT UNLESS ANOTHER PERSON TRAINED IN FIRST AID AND CPR IS PRESENT.
- CONNECT ALL DISCONNECTED EQUIPMENT GROUND CABLES AND WIRES AFTER SERVICING EQUIPMENT. GROUND ALL CONDUCTIVE EQUIPMENT.
- USE ONLY APPROVED ADB SAFEGATE REPLACEMENT PARTS. USING UNAPPROVED PARTS OR MAKING UNAPPROVED MODIFICATIONS TO EQUIPMENT MAY VOID AGENCY APPROVALS AND CREATE SAFETY HAZARDS.
- CHECK THE INTERLOCK SYSTEMS PERIODICALLY TO ENSURE THEIR EFFECTIVENESS.
- DO NOT ATTEMPT TO SERVICE ELECTRICAL EQUIPMENT IF STANDING WATER IS PRESENT. USE CAUTION WHEN SERVICING ELECTRICAL EQUIPMENT IN A HIGH-HUMIDITY ENVIRONMENT.
- USE TOOLS WITH INSULATED HANDLES WHEN WORKING WITH AIRFIELD ELECTRICAL EQUIPMENT.

FAILURE TO FOLLOW THESE INSTRUCTIONS CAN RESULT IN DEATH OR EQUIPMENT DAMAGE

2.0 LINC 360Controller

The LINC 360Controller is a key subsystem in various Airfield Ground Lighting Automation Systems. ADB SAFEGATE's LINC 360 system is the latest state-of-the-art individual airfield light control and monitoring system. LINC 360 provides a radical leap in performance over prior airfield power line carrier systems. This system is designed to communicate on the existing airfield series circuit power line without requiring separate dedicated cabling. This system has patents pending in many countries around the world.

Proprietary Information

General notice: Other product names used here are for identification purposes only and may be trademarks of their respective companies.

2.1 Manual Introduction

This document provides a manual on installation of LINC 360Controller.

In the following chapters, detailed information about commissioning, replacing and maintaining LINC 360Controller is presented.

2.1.1 How to work with the manual

1. Be familiar with the structure and content.
2. Carry out the actions completely and in the given sequence.

2.2 LINC 360Controller Introduction

The LINC 360Controller is ADB SAFEGATE's state-of-the-art individual lamp control and monitoring system. LINC 360 provides a radical leap in performance over prior airfield power line carrier systems. The system is designed to communicate on the existing airfield series circuit power line without requiring separate dedicated cabling.

2.2.1 Individual Lamp Control & Monitoring System (ILCMS)

Compliance with Standards

FAA:	Approved for use with SMGCS Systems. This includes both Stop Bar and Runway Guard Light control/monitoring according to AC 150/5340-30 (Current Edition), AC 150/5345-56BAC (Current Edition); manufactured to AC 120-57 (Current Edition).
ICAO:	Complies with CAT I/II/III ICAO lamp supervision requirements. Supports A-SMGCS for enhanced aircraft guidance in all weather conditions. Supports safety of airport operations by integration in runway safety nets.

Uses

LINC 360 provides distributed intelligence in the airfield to control and monitor a variety of airfield lighting devices. It can be used in the following applications:

- Key component of (Advanced-) Surface Movement Guidance Control Systems: (A-)SMGCS
- Stop bar control and monitoring: taxiway routing support.
- Elevated and in-pavement Runway Guard Light (RGL) control and monitoring, CAT II/III monitoring support.
- Failed-lamp detection and location identification.
- Interface with aircraft/vehicle presence sensors (option).
- Selective control and monitoring of various airfield lighting devices.

The system provides relevant information concerning the status of connected airfield lighting devices to both airport maintenance and air traffic control personnel.

Furthermore LINC 360:

- Supports the optimization of traffic volume, flexibility, maintainability and airside safety.
- Ensures reliable guidance for aircraft on the ground during CAT I, II or III conditions, increasing safety and reducing the risk of runway incursions.
- Automatically detects and reports lamp failures, decreasing downtime and maintenance costs.

Customer Benefits

- Faster, predictable and more robust power line carrier communication method ensures highest reliability, even for long airfield circuits that contain large number of lamps.
- Increased number of slots per day as a result of higher traffic throughput and better control of ground traffic movements.
- Flexible routing functionality and safe operation under all traffic and environmental conditions resulting in reduced ATC workload.
- Precise control of each segment of runways, taxiways, and stop bar lighting.
- Adjacent lamp failure reporting.
- Most economic solution for modernization projects through power line communication on existing circuits.
- Easy future upgrade of installed LINC 360 systems.
- A step-by-step migration strategy can then be implemented.
- Optimized planning of runway and taxiway maintenance downtimes.
- Worldwide availability of our regional Technical Service staff for technical support and site services on short notice.

LINC 360 Technology

- Communicates using a radio frequency signal imposed on the high- voltage airfield series circuit cable - no separate communication cable needed.
- Communication quality is automatically optimized for each series circuit in a permanent background process.
- New communication principle together with forward error correction drastically reduces signal disturbance caused by impulse and narrow band interferences.
- Main system elements: LINC 360 Controller (in the substation), LINC 360 Remotes (for individual control and monitoring of lights in the field). In addition, LINC 360 Utility Device for communication with and energy supply for local field sensors.

Features

- No separate communication cable required. RF signal on high voltage power cable for lighting control.
- Most cost-effective and proven solution for existing ground lighting systems.
- User friendly integrated web server allows easy operation and system status recognition.
- Up to 11 different frequency bands can be used in parallel, and up to 32 different timeslots which allow an increase in the number of independent communication channels up to 176.
- Fast and predictable switching times through the use of reliable communication methods and limited repeater levels.
- Synchronizing of control systems in different vaults by Ethernet in compliance with IEEE 1588.
- Single Frequency Network system includes an automatic network configuration function. This functionality provides for dynamic communication adaptation in all environmental conditions (such as humidity variation). The system dynamically checks repeater settings and automatically sets them, even if a Remote in the communication path has failed.
- Less crosstalk due to symmetrical design of coupling components (transmit and receive path), independent communication channels and lower transmission power compared to similar systems in the market.
- Can be used as a stand-alone monitoring system or integrated with an Airfield Lighting Control System (ALCS).
- Individual control of different functions in one lamp circuit. For example, a combination of Stop Bar and Lead-In Circuit.
- Optional Runway Guard Light Remotes, automatic start and net-synchronous Wig-Wag operation, independent from Controller meeting FAA requirements.
- Firmware and application software can be downloaded into either the Controller (substation) or Remotes (field units).

- State-of-the-art diagnostic tools provide a quick overview about communication behavior. Network management system provides detailed routing statistics to ensure reliable communication quality.
- Field sensors can be integrated via Utility Devices into the LINC 360 lamp control and monitoring circuit for detection and transmission of local surveillance information via power line communication.
- Able to work with any kind of CCR and designed for 40 Ampere peak current.

Main Characteristics and Figures

- Up to 300 Remotes or AXON EQ Lights per circuit, providing a potential of 600 individually addressable lights per circuit.
- Up to 20 km roundtrip circuit length.
- Configurable block evaluation modes include full feedback, small sample feedback, and optimistic feedback.
- Can command 10 blocks to 10 distinct states with one power-line message. Can command all blocks to one state with one powerline message.
- Switches up to 120 lights in 10 different groups in less than 1 second.
- Switches 5 stopbar/lead-on lights simultaneously and presents real-back indication in less than 1 second.
- Status poll provides detailed Remote and lamp parameters.

Integrated System Control

Overall system configuration and control is realized via a control process with integrated web server for configuration and maintenance.

- Each circuit is equipped with a microprocessor-controlled Controller for tracking, recording and management of state of all Remotes in the circuit.
- The Controller communicates with all the Remotes (or integrated AXON EQ light fixtures) in a circuit and polls all lamps independent from the control system.

Overall System Specifications

Description	Remote	Controller
Operating temperature	-40 °C to +65 °C	0 °C to +55 °C
Storage temperature	-55 °C to +85 °C	-40 °C to +75 °C
Operating humidity	Max. 100 %	Max. 95 % non condensing
Series circuit operating voltage	-	Max. 5000 V AC RMS
Min. / max. Power line current	1.8 up to 8.25A RMS	1.8 up to 8.25A RMS
Maximum Open Circuit Voltage		10,000 V AC RMS
Series circuit peak voltage	-	Max. 15 kV
Maximum switching power secondary side of transformer	300 W (single Remote) Ch A + Ch B < 300 W (dual)	-
Maximum circuit load (CCR power)	-	30 kVA

Description	Remote	Controller
Enclosure protection level	IP 68 / NEMA 6 P	IP 20
LAN connection to upper control system	-	IEEE 802.3 100 BaseT / IEEE1588 PTP
Net voltage of power supply	-	115 - 230 V AC ±15 %, 50/60 Hz
MTBF	> 200.000 h	> 200.000 h
Indicative MTTR	< 30 min	< 60 min
Lightning protection	20 kA (8/20 micro sec.)	17 kA (8/20 micro sec.)

Description	Remote	Controller
EMC (CE approved)	Compliant to the EN 61000-6-4 (EMC emission standard) Compliant to the EN 61000-6-2 and 6-5 (EMC immunity standard)	
Power Up Mode	On; Off; Flashing; Maintained (last commanded state)	
Fail-Safe Mode	On; Off; Flashing, Maintained (last commanded state)	
Number of controlled and monitored lamps per unit	1 or 2	Up to 300 Remotes or 600 lights, if dual Remotes are used
Number of Utility Devices per circuit	-	Max. 16
Transmit Frequency	11 different frequency bands between 20 kHz and 200 kHz	
Data transmission rate power line	Up to 8 kbps	Up to 8 kbps

Description	Remote	Controller
Dimensions (W x H x D) / Weight	204 x 76 x 140 mm / 1.2 kg (single Remote) / 1.3 kg (dual)	420.7 x 177.8 x 504.8 mm / 29.82 kg
Lamp failure reaction	Short is placed across isolation transformer as soon as lamp filament failure detected	
Power Storage after Power-Off	Remote does not reset and remains in operation, if circuit power loss < 2 sec. Remote start up time is less than 1 sec.	

Circuit Specifications

Cable type L-824 is recommended, for example FLYCY or equivalent. The following parameters (*) represent the specific characteristic needed in an equivalent L-824 cable. Reuse of existing installations and layout with maximum cable length or number of lights to be verified.

Cable type (specification)	L-824
Capacity of the cable	<165 nF/km ¹
Inductance of the cable	<0.20 mH/km ¹
Typical impedance (125 kHz)	35 Ohm
Attenuation of the signal at 125 kHz	<5.8 dB/km ¹
Length of serial circuit	20 km roundtrip (12.4 miles) maximum
Insulation resistance of the series circuit against the L-824 shield or ground	50 Megaohms minimum ²
Secondary transformer attenuation	≤ 23 dB at 100 kHz ¹

¹Contact ADB SAFEGATE for support

²Technical requirement, not excluding ICAO/FAA compliance

System Overview

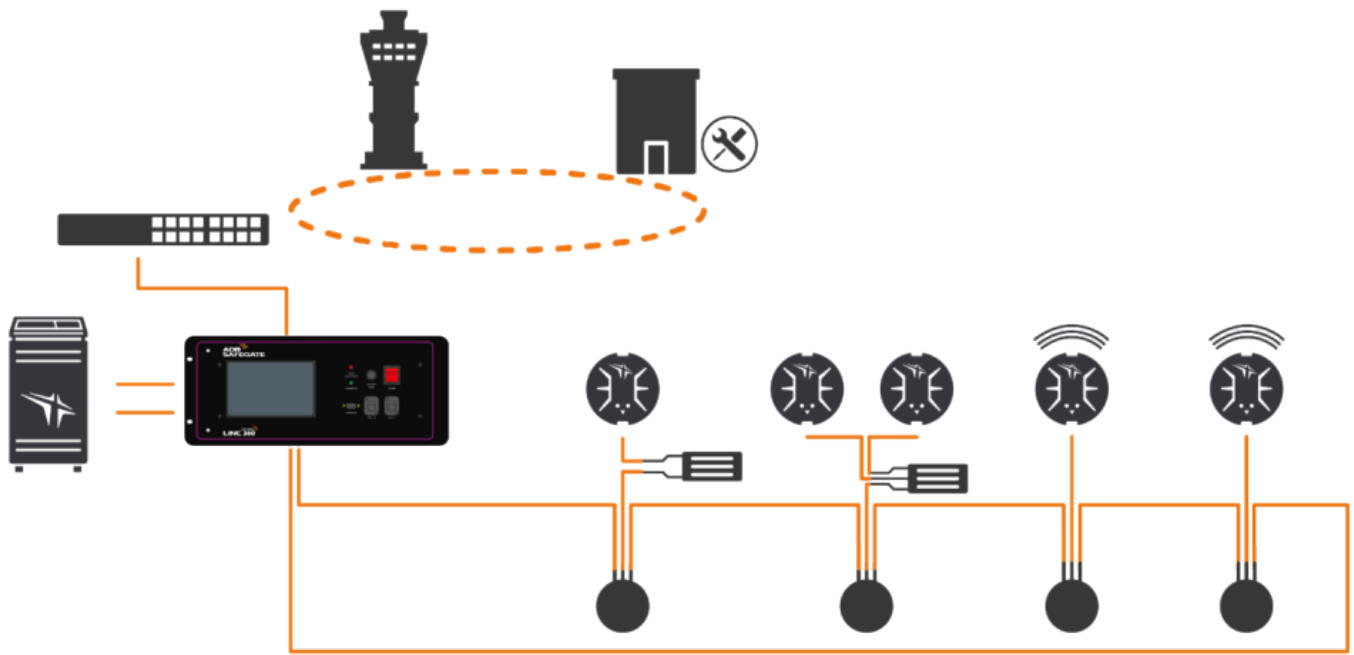

Airside 4.0

To enable Airside 4.0 use cases, such as Axon EQ Sealing Leakage Detection or LINC 360 Performance Monitoring, an internet Cloud Connection is needed. There are several ways to accomplish this as shown in the following figure. Contact your Sales Representative for more information.

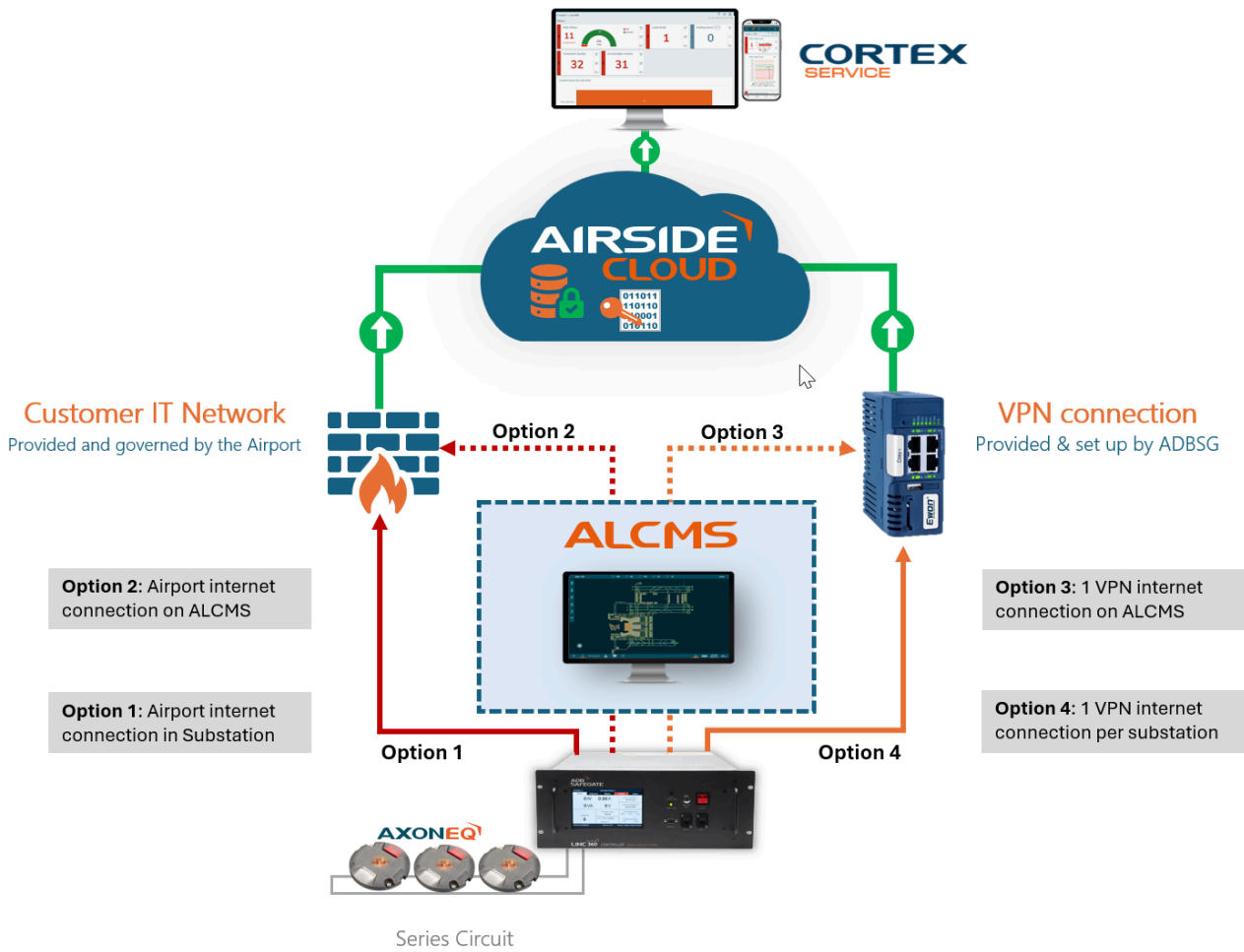

Table 1: Ordering Code: Controllers

Description	Part No.
LINC 360 Controller, 19" Rack Mount, EU plug	LINCC0000000101
LINC 360 Controller, Wall Mount, Door Open Left (EU)	LINCC0000000201
LINC 360 Controller, Wall Mount, Door Open Right (EU)	LINCC0000000301
LINC 360 Controller, 19" Rack Mount, US plug	LINCC0000000111
LINC 360 Controller, Wall Mount, Door Open Left (US)	LINCC0000000211
LINC 360 Controller, Wall Mount, Door Open Right (US)	LINCC0000000311
LINC 360 Controller, 19" Rack Mount, UK plug	LINCC0000000121
LINC 360 Controller, Wall Mount, Door Open Left (UK)	LINCC0000000221
LINC 360 Controller, Wall Mount, Door Open Right (UK)	LINCC0000000321
LINC 360 Controller, 19" Compact (no flanges)	LINCC0000000501

Table 2: Ordering Code: Remotes

Description	Part No.
LINC 360 Single Channel Remote, FAA Style 7	AGC4170
LINC 360 Single Channel Remote, FAA Style 8	AGC4180
LINC 360 Single Channel Remote, FAA Style 7, Initial Flash Off	AGC4270
LINC 360 Single Channel Remote, FAA Style 7, Initial Flash On	AGC4370
LINC 360 Dual Channel Remote, FAA Style 7	AGC5170
LINC 360 Dual Channel Remote, FAA Style 7, Channel A Initial Flash On, Channel B Initial Flash Off	AGC5470
LINC 360 Utility Device (Above Ground Installation only)	AGC6110
LINC 360 Power Remote 13.5 Vdc	LINCP00000130001



Note

Axon EQ with integrated modem: please consult the Axon Lights Datasheet.

2.2.2 Illustration

Figure 1: LINC 360 Controller front view



Figure 2: LINC 360 Controller front view (uncovered)



2.2.3 LINC 360 Technology

- Communicates using a radio frequency signal imposed on the high- voltage airfield series circuit cable - no separate communication cable needed.
- Communication quality is automatically optimized for each series circuit in a permanent background process.
- New communication principle together with forward error correction drastically reduces signal disturbance caused by impulse and narrow band interference.
- Main system elements: LINC 360Controller(in the substation), LINC 360Remote (for individual control and monitoring of lights in the field). In addition, LINC 360Utility Device for communication with and energy supply for local field sensors.

2.2.4 Terms

General Aviation Terms and Acronyms that you may encounter using our manuals.

Table 3: Terms

Term	Definition
ALCMS	Acronym for Airfield Lighting Control Monitoring System. An ALCMS incorporates many components that are used to control and monitor an airport's entire airfield lighting system. The ALCMS may include Touch Screens for lighting control, Maintenance Center(s) for data viewing and archiving, Electrical Lighting equipment for CCR control and monitoring.
CCR	Abbreviation for Constant Current Regulator. The CCRs are located within the Airfield Lighting Vault (ALV). They produce a constant current output to the airfield series circuit that light the airfield lighting fixtures.
LINC 360Remote, Controller, PC	ADB SAFEGATE's trademarked abbreviation that describes the future proofing technology used to transmit and receive data across airfield lighting series circuit cabling.
Remote	Unit installed in the airfield (normally in pull-pits or base cans) which provides control and monitoring of individual or blocks of light fixtures. Each Remote has its own unique address for control and monitoring data communication to the Controller.
Controller	Unit installed within the lighting vault that provides the means for data communication on the airfield series circuit cables. The Controller is connected in parallel (across) to the output of the CCR. Each series circuit that contains Remotes must also have a Controller installed at the CCR.
Control Panel	This term is used to reference the device used to control and monitor the controllable stopbars and the associated lighting equipment. The control panel could be either an L-821 style push-button panel or a Touchscreen style control panel. The control panel is located in the Air Traffic Control Tower cab.
SMGCS	Acronym which means Surface Movement Guidance and Control System. SMGCS is an organized system created to improve and enhance low visibility operations.

2.3 Checking the Device

2.3.1 Scope of Supply

The LINC 360Controller is supplied with four 19-inch (0.5-m) long cord-set cables for connection to the high-voltage lines from the series circuits, and includes an instruction manual.

2.3.2 Unpacking

The device has been fully assembled, tested and packed at the factory and has no internal transport locks.



Note

In case of significant differences in temperature between the means of transport and the place where the device is to be unpacked, it is recommended to leave the device in its packaging for acclimatization, in order to avoid damage from condensation, e.g. 12 hours for a 30 °F / 20 °C temperature difference, longer with greater differences.

2.3.3 Inspection

The delivery must be checked to make sure that it is complete and in perfect condition. The supplier must be notified of any complaints within 2 weeks. After this period, complaints about the delivery will not be accepted. In the event of the goods being returned, the same transport packaging must be used. The number on the nameplate must be checked against the order number on the delivery note. The nameplate, [Figure 3](#) is located on the side of the device (example: LINC 360 Controller 30 kVA).

Figure 3: Nameplate of the LINC360 Controller

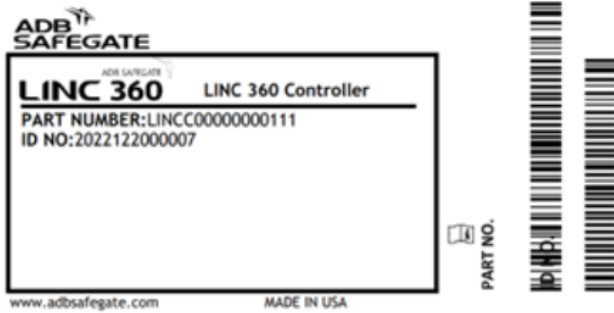

The address (MAC ID) of the Ethernet interface *Eth0* and *Eth1* should be recorded and will be utilized during commissioning. Found on the ABOUT screen.

2.4 Storage

If the LINC 360 Controller has to be stored for a longer period between receipt and installation, it is recommended to leave the device in its transport packaging.

If the LINC 360 Controller has to be stored without its packaging, it must be stored in a clean, dry location in order to prevent contamination via the ventilation slots in the top cover plate.

The storage temperature is shown in ["Technical Specifications"](#).



Note

Allow the LINC360 Controller to acclimatize prior to installation for 12 hours before switching on power and the high voltage in the series circuit.

2.5 Views of the Device

2.5.1 Front View with Control Unit

This is an example. Figure 4 is an illustration that shows the front view of the control unit and [Fig 1.x] the front panel.

Figure 4: Front view with Control Unit of the LINC 360 Controller



The high-voltage units for the series circuit can be found behind the front panel:

- Capacitor Bank
- Inductors
- High Voltage Board
- Overvoltage Protection

Figure 5: Front panel of the Control Unit of the LINC 360 Controller

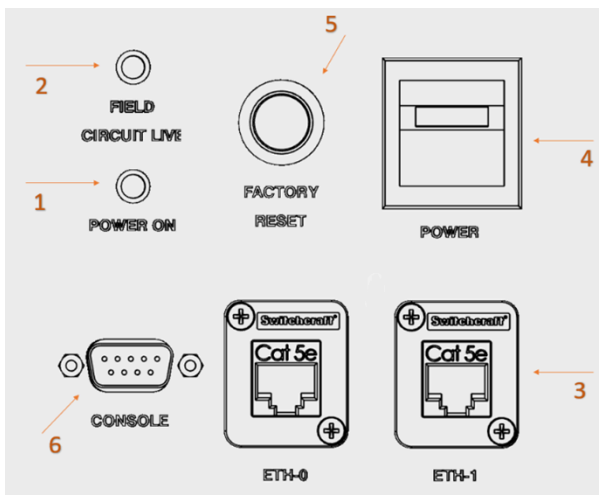

The Control Unit's individual operation and display elements have the following functions:

1. Power On LED red
 - Constant current regulator is switched on.

2. Field Circuit Live LED amber
 - System is running
3. eth 0 and eth 1, Eth RJ-45 interface
 - 100Mbit TCP/IP network interface
 - For communication with LINC 360 PC via a hub or switch. The user can determine the IP address that must be assigned to this connection (software function).
 - The address (MAC ID) of the interfaces are found on the ABOUT screen of the LINC 360Controller.
4. Main Power connections
 - Main power switch
5. Factory Reset
 - This button resets LINC 360Controller to the delivery condition (FLASH pages including the current configuration, logs and IP addresses are deleted).
 - Hold the reset button down from power on until the Controller reboots.
6. Console Port
 - This port is to be used for debugging or commissioning purposes only.

2.5.2 Rear View with Connections

Figure 6: Rear view of the LINC 360 Controller

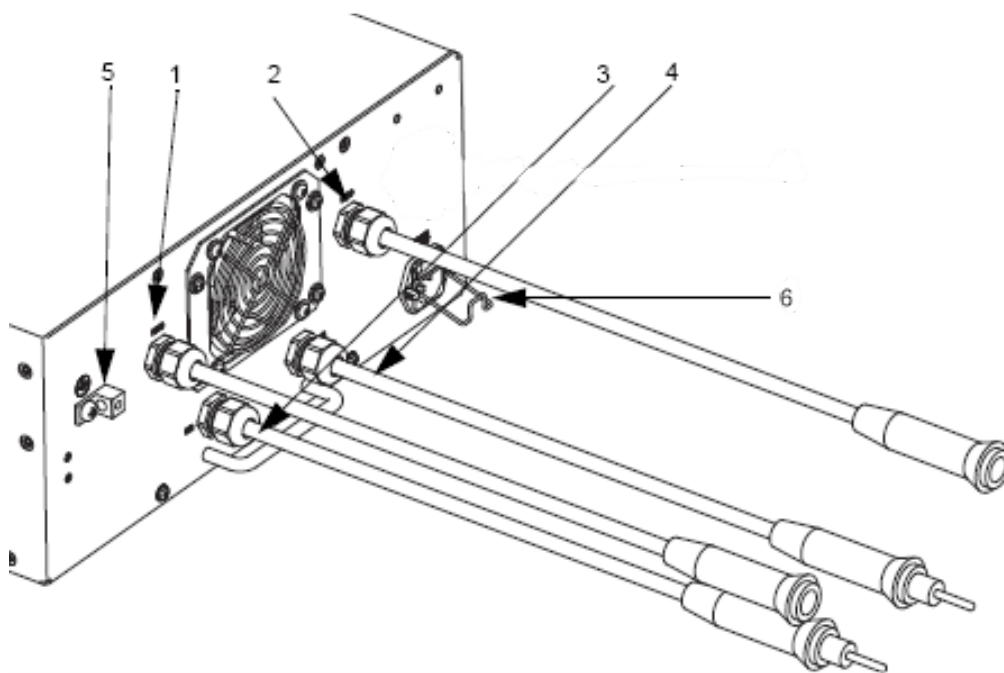

1. Cable with connection **socket** to series circuit
2. Cable with connection **socket** to series circuit
3. Cable with connection **plug** to Constant current regulator or Filter
4. Cable with connection **plug** to Constant current regulator or Filter
5. Screw for earth ground connection
6. Input Power (115-230 Vac 50/60 Hz)

2.6 Theory of Operation

Background Information: LINC 360 uses power line carrier (PLC) technology to communicate between controlling units on an airfield lighting series circuit. A LINC 360 system typically consists of one high voltage modem, or Controller installed behind the Constant Current Regulator (CCR) powering the airfield lighting circuit and Remotes placed with individual lights in the field or lights with integrated modems (Axon EQ). A typical LINC 360 topology is provided in [Figure 7](#).

Figure 7: Typical LINC 360 Topology

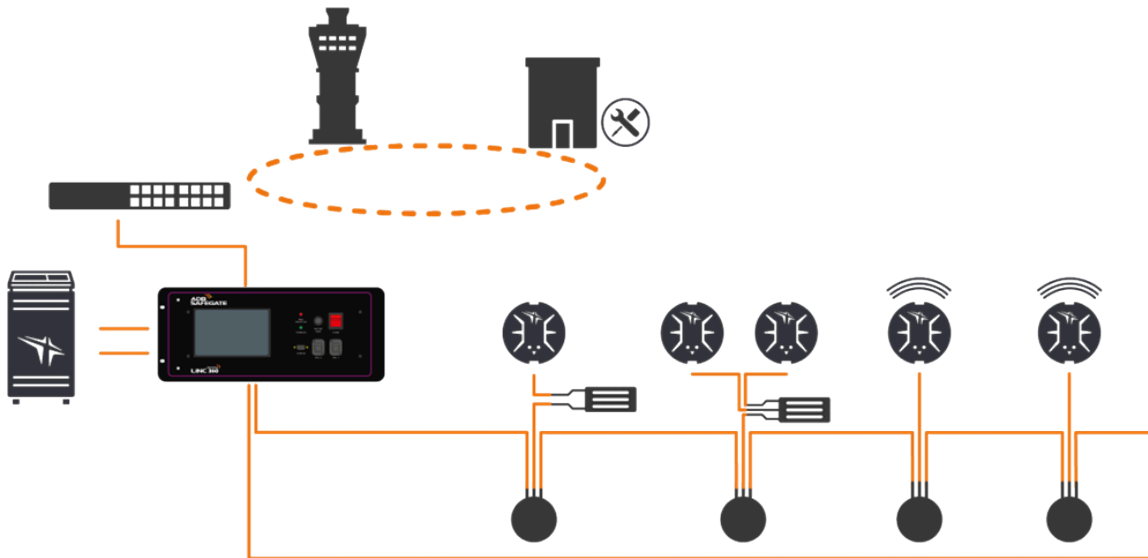

2.6.1 Main Characteristics and Figures

- Up to 300 Remotes per circuit, providing a potential of 600 individually addressable lights per circuit.
- Up to 20 km round-trip circuit length.
- Configurable block evaluation modes include full feedback, small sample feedback, and optimistic feedback.
- Can command 10 blocks to 10 distinct states with one powerline message. Can command all blocks to one state with one powerline message.
- Switches up to 600 lights, in 10 different groups, in less than 1 second.
- Switches 5 stopbar/ lead-on lights simultaneously and presents real-back indication in less than 1 second.
- Status poll provides detailed Remote and lamp parameters.

2.6.2 Integrated System Control

Overall system configuration and control is realized via a control process with integrated web server for configuration and maintenance.

- Each circuit is equipped with a microprocessor-controlled Controller for tracking, recording and management of state of all Remotes in the circuit.
- The Controller communicates with all the Remotes (not light fixtures) in a circuit and polls all lamps independent from the control system.

2.6.3 Architecture

Figure 8 depicts the general nature of the system components and their interactions. The “Control System” is an external ALCMS system that provides controlling commands and digests Controller and Fixture status reports. There is typically only one control system in the architecture. The “Controller” is the high voltage modem that communicates commands to and receives status from the fixtures. There can be many Controllers in a given system. Controllers digest commands from the control system and provide status to it. Controllers also communicate among themselves to maintain communication timing synchronization. Each Controller communicates with the fixtures on its respective circuit.

Figure 8: Series Circuit Controller/ Fixture Architecture

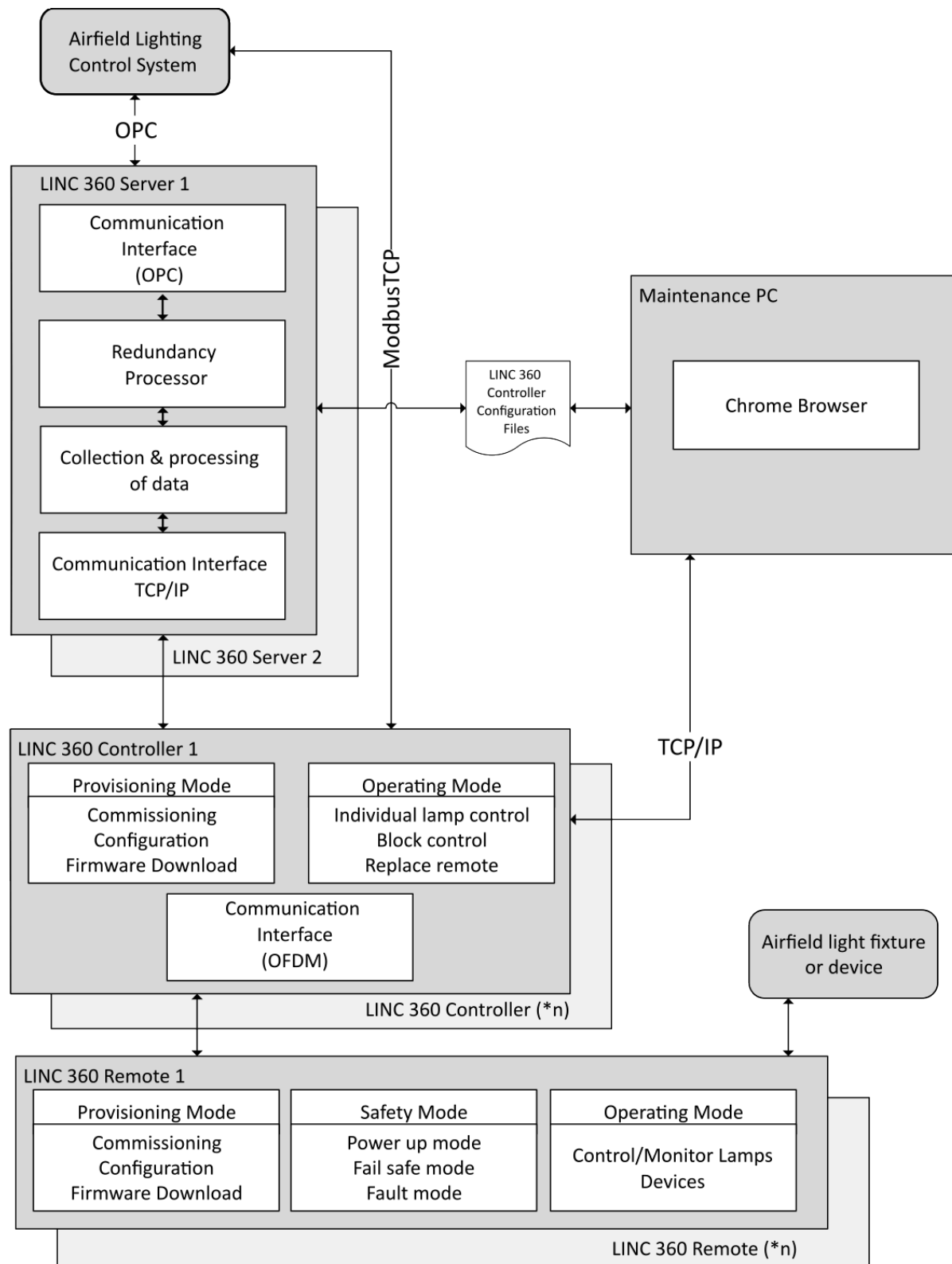

2.7 Modes of Operation

More information about the modes of operation contact your ADB SAFEGATE representative.

2.7.1 State on Delivery

The LINC 360Controller is delivered with no default IP address set for either Ethernet interfaces *Eth0* (Eth 0) and *Eth1* (Eth 1). The address must be entered by the user via the LINC 360 PC.

The following are the states of the LINC 360Controller:

- BootStrap
- Offline
- Provisioning
- Operational
- Failsafe
- Critical Fault

2.7.2 HMI Display Screen

Header: The header is always displayed on every screen and shows the Controller ID, Controller Name, and a lightning bolt indicating if the circuit is energized or not.

Footer: The footer is always displayed on every screen and shows the current date/time, the version of the Controllerfirmware, and the uptime of the Controller.

2.7.3 Status Screen

The status screen gives detailed status information of the Controller. The upper left section details the power readings of the circuit (watts, Amps, volt amps, volts). The upper right section shows the IP addresses of the two network interfaces. The bottom left corner shows how many lamps are out on the circuit. The bottom center sections shows the Controller status, the status of the PTP synchronization with other Controllers, and which network is currently being used. The bottom right corner shows the number and type of connected clients.

Controlling clients:

- M = Maintenance, F = Full Operational, P = Partial Operational

Monitoring clients:

- F = Full Monitoring, P = Partial Monitoring

Figure 9: Status screen. Right: Status screen when no current is detected by the controller.

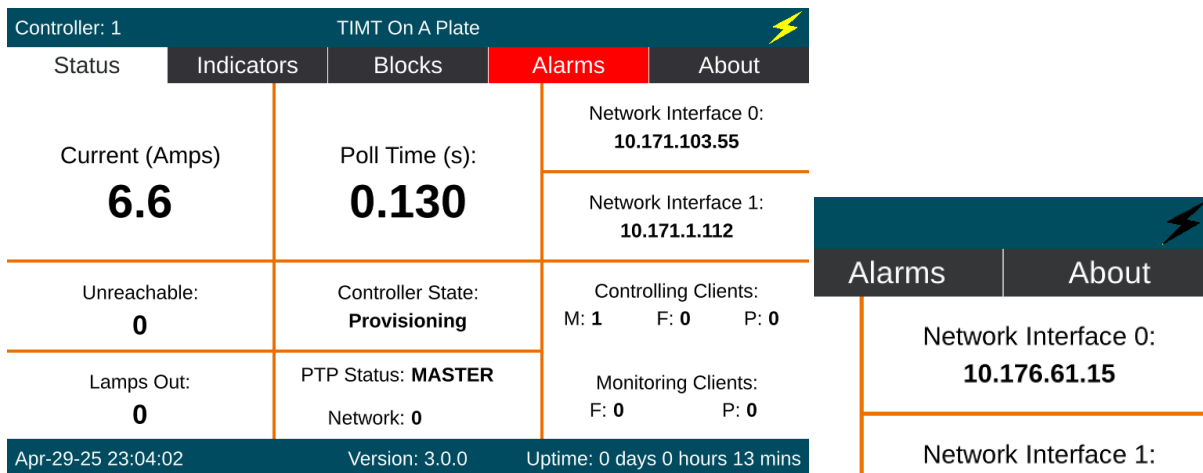

Note

The electrical values shown are purely indicative. The controller is not meant to serve as an accurate measuring device. Do not compare with CCR measurement values.

2.7.4 Indicators Screen

The indicators screen is the default screen. Its purpose is to show the high level state of the Controller at a glance. The "Control" and "Monitor" indicators will turn blue when controlling or monitoring clients are connected. The "ControllerHealth" and "Circuit Health" indicators are green when the Controller and circuit are healthy. If there are warnings for the Controller or circuit they will turn yellow. If there are Controller or circuit alarms they will turn red.

Figure 10: Indicators screen. Right: Different colors for every state, only one active at a time.

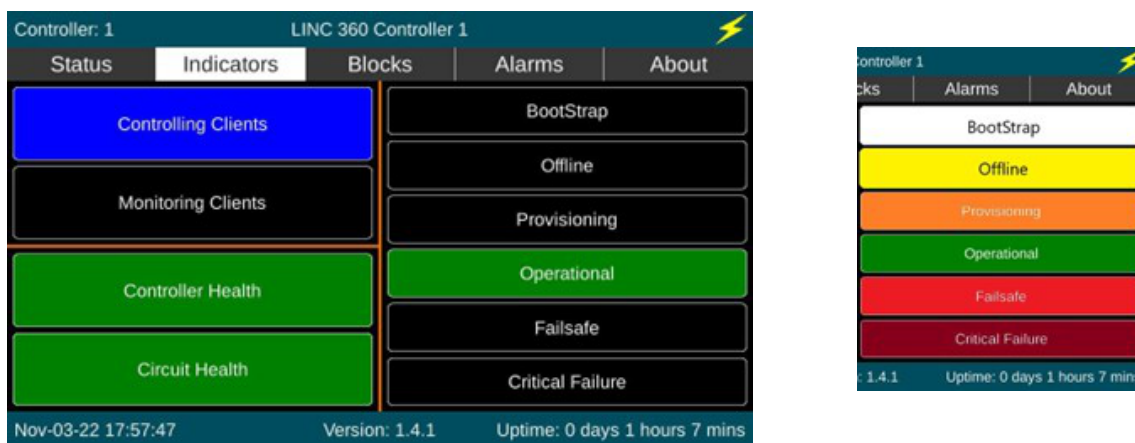
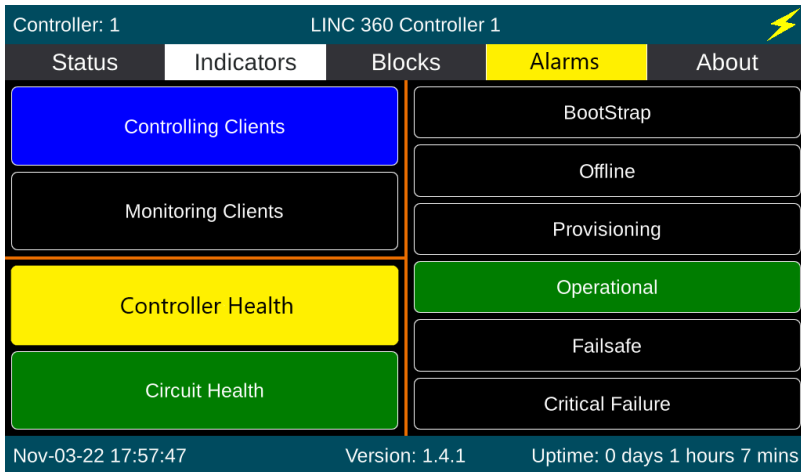

Figure 11: Indicators with warnings



The "Controller Health" and "Circuit Health" indicators are green when the Controller and circuit are healthy. If there are warnings for the Controller or circuit they will turn yellow. If there are Controller or circuit alarms they will turn red.

Figure 12: Indicators with Alarms and Warnings. Left: Indicators with Monitoring Client

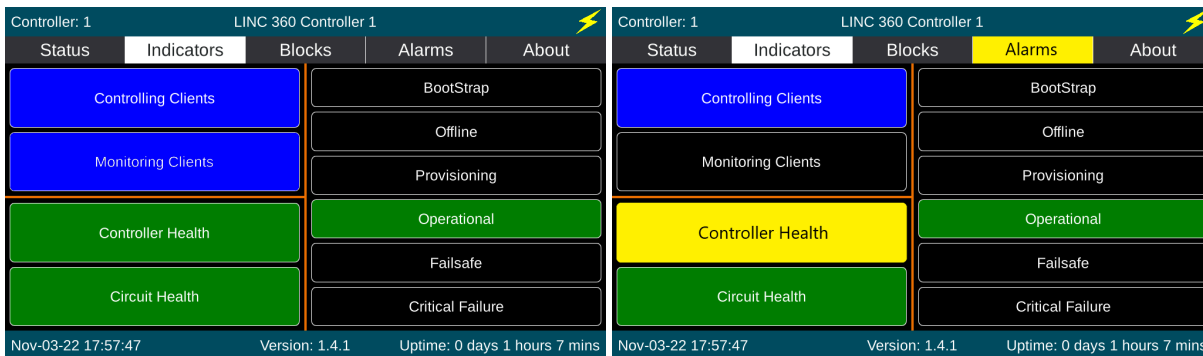
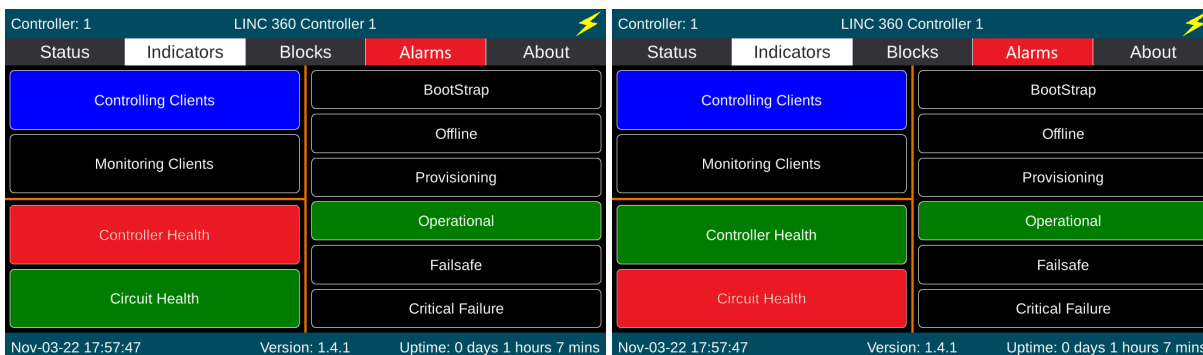

Figure 13: Left: Indicators with Alarms. Right: Indicators with Circuit Alarms



2.7.5 Alarms Screen



Note

The Alarm and Log Screen were combined in Controller Units with firmware version 1.3 and later.

The alarm screen will show currently active alarms and warnings. When the alarm or warning clears the row will be removed from this table. The date and time shown is the date/time at which point the alarm or warning became active.

When viewing other tabs, any incoming alarms or warnings will turn the tab for the Alarms screen yellow for warnings and red for alarms. If both alarms and warnings occur the tab will be red.

Figure 14: Alarm screen

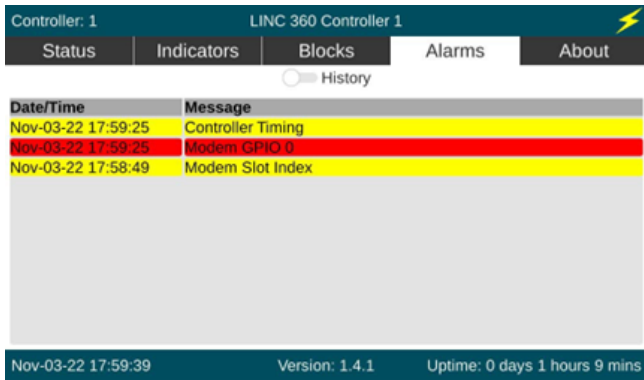

2.7.6 Alarms History Screen



Note

In older Controller versions this used to be the "Log" screen.

The alarm history screen shows a history of alarms and warnings as well as the date/time they were raised and were cleared.

Figure 15: Alarms history screen

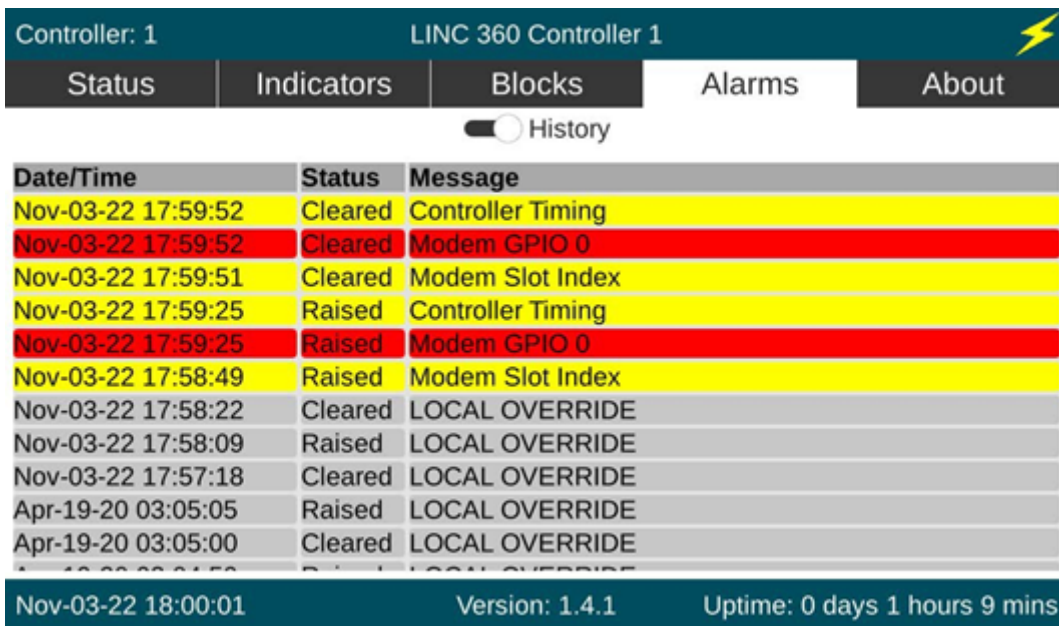

2.7.7 Block Screen

Figure 16: Block Screen

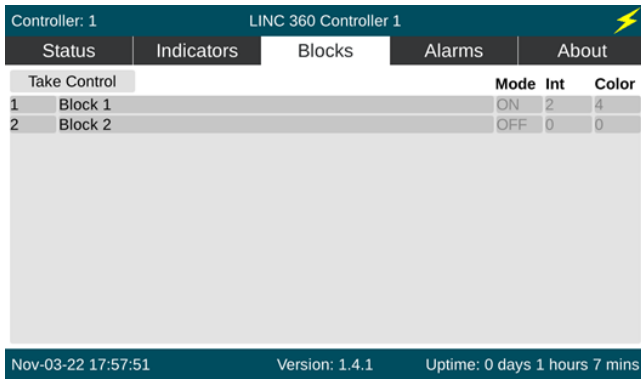
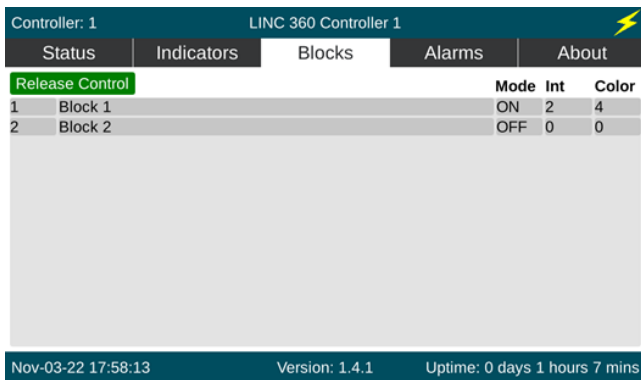

Figure 16: Blocks screen while in local control



These screenshots show the user navigating the list of blocks and hitting the end of the configured blocks. This Controller only has 20 configured blocks. While the user has control, they can touch the "Mode" button next to the block to change its state to ON or OFF. This will cause the Controller to command the block on or off affecting the state of the lamps on the airfield.

The user can take local control by clicking on the field "Take Control", this will then change to "Release Control" in green. When the user has given up local control the tab will go back to the standard gray color "Take Control".

Figure 18: Blocks scroll of list

Controller: 1 LINC 360 Controller 1

Status Indicators **Blocks** Alarms About

Take Control

		Mode	Int	Color
1	Block 1	OFF	0	0
2	Block 2	OFF	0	0
3	Block 3	OFF	0	0
4	Block 4	OFF	0	0
5	Block 5	OFF	0	0
6	Block 6	OFF	0	0
7	Block 7	OFF	0	0
8	Block 8	OFF	0	0
9	Block 9	OFF	0	0
10	Block 10	OFF	0	0
11	Block 11	OFF	0	0
12	Block 12	OFF	0	0
13	Block 13	OFF	0	0

Jan-10-23 16:26:04 Version: 2.0.0 Uptime: 0 days 0 hours 39 mins

Controller: 1 LINC 360 Controller 1

Status Indicators **Blocks** Alarms About

Take Control

		Mode	Int	Color
8	Block 8	OFF	0	0
9	Block 9	OFF	0	0
10	Block 10	OFF	0	0
11	Block 11	OFF	0	0
12	Block 12	OFF	0	0
13	Block 13	OFF	0	0
14	Block 14	OFF	0	0
15	Block 15	OFF	0	0
16	Block 16	OFF	0	0
17	Block 17	OFF	0	0
18	Block 18	OFF	0	0
19	Block 19	OFF	0	0
20	Block 20	OFF	0	0

Jan-10-23 16:26:53 Version: 2.0.0 Uptime: 0 days 0 hours 40 mins

In this screen shot the user has touched the "Int" (short for Intensity) button next to "Block 2". Block 2 is highlighted and an Intensity popup slides out from the right of the screen showing the current intensity of the block. The popup allows the user to command the intensity of the block. To close the popup without changing the intensity simply touch anywhere outside of the popup. Intensity is only available for Axon EQ and ADAL Light and must be configured as such.

Figure 19: Blocks changing intensity

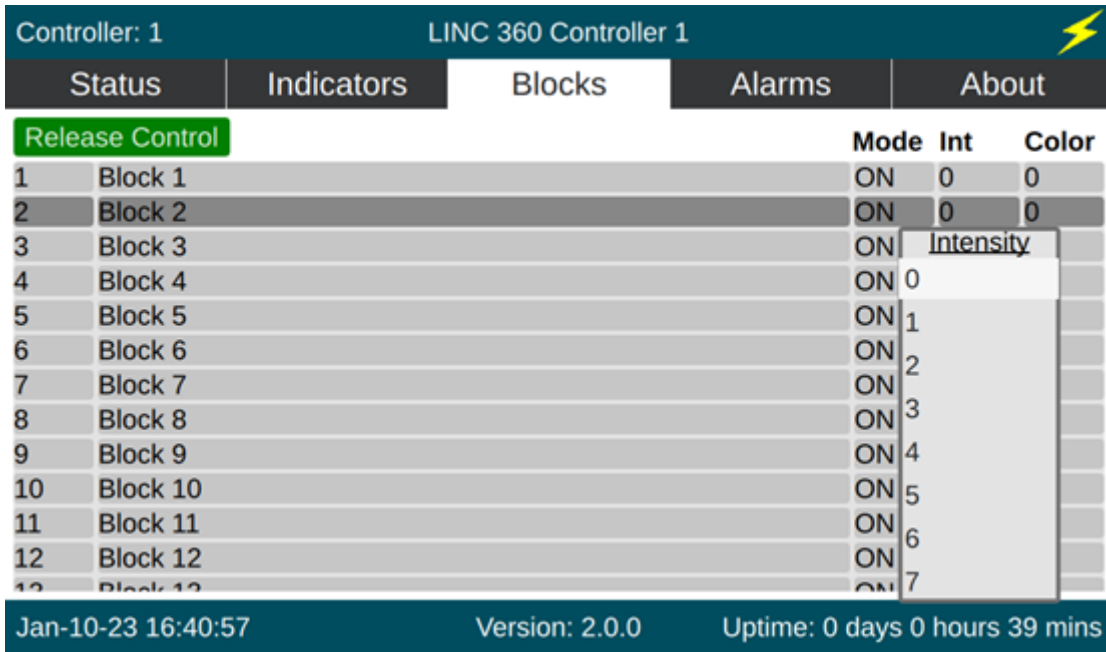

In this screen shot the user has touched the "Color" button next to "Block 2". Block 2 is highlighted and a Color popup slides out from the right of the screen showing the current color of the block. The popup allows the user to command the color of the block. To close the popup without changing the color simply touch anywhere outside of the popup.

Figure 20: Blocks changing color

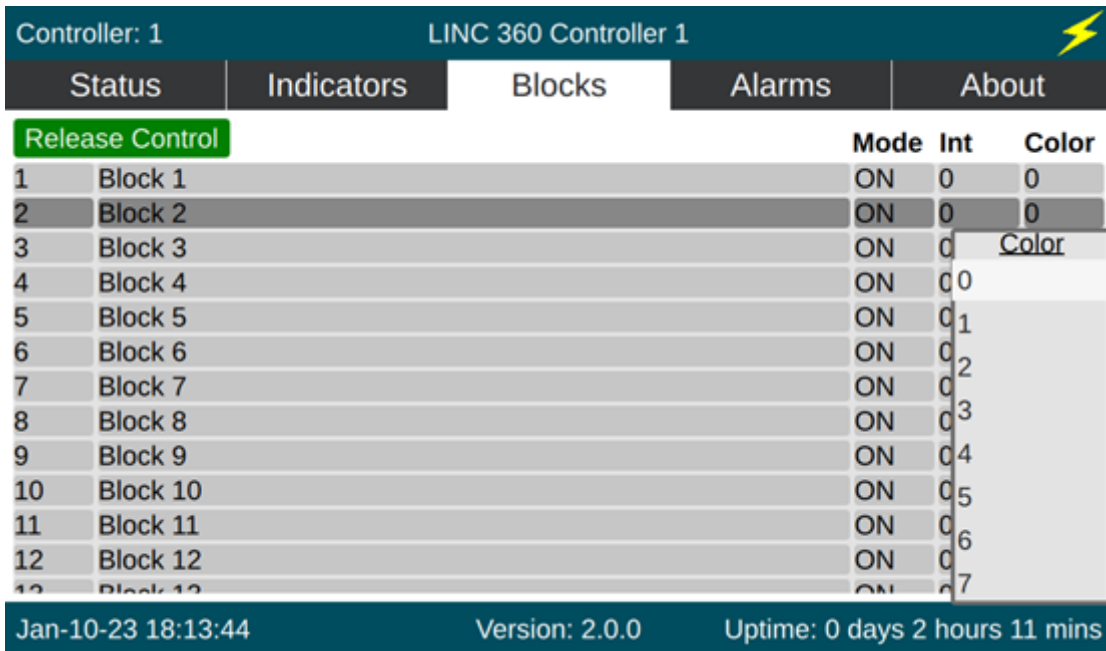

Color is reserved for the ADAL multicolor lights and must be configured as such.

2.7.8 About Screen

This screen shows the MAC address of the two Ethernet connections on the Controller. The MAC addresses are used when sending a BootP message to initially configure the machine. The version of the HMI touch screen software is also shown.

Figure 21: About screen

This screen shows the MAC address of the two Ethernet connections on the Controller. The MAC addresses are used when sending a BootP message to initially configure the machine. The version of the HMI touch screen software is also shown.

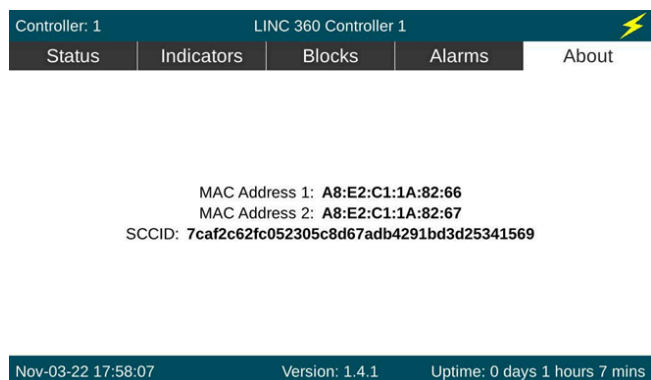

3.0 Installation of stand-alone LINC 360Controllers

3.1 Installation in the Control Cabinet



Note

The LINC 360 Controller is designed for protection class IP 20 (NEMA 1) according to IEC 529 and is approved for contamination grade 1 according to IEC 60 664-1 (operation in dry air-conditioned spaces). If the Controller is to be installed in a workshop environment, a 19" enclosure with active ventilation is highly recommended. The environmental conditions are defined in "Overall System Specifications".

The airflow is from front to back through the LINC 360Controller units to ensure enough ample room behind the units for proper cooling and air flow.

The devices should be mounted on rails, brackets or tilting racks. They are to be fixed with the 4 clamp bolts positioned on the front.

The ground cables of the LINC 360Controllers must be connected to the bus bar in the electrical cabinet.

The control cabinet bus bar must be connected by a wire with a minimum cross-sectional area of AWG 0 (50mm²) to the central earth ground in the control room.

Figure 22: Rack controller diagram

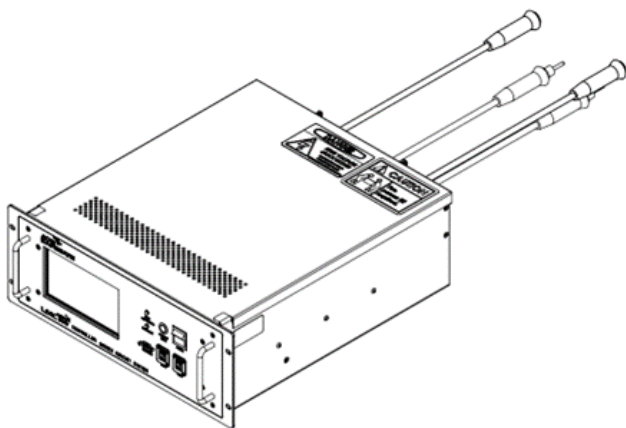

3.1.1 Power Supply

The power cable (18 AWG (0.75mm²) recommended) is to be provided by the user. The plug supplied is to be attached to the cable. The cable is used to connect the mains socket POWER at the rear of the LINC 360 to the cabinet power supply.

It is recommended that each LINC 360Controller be individually fused with a 6 A circuit breaker. It is also recommended that the controllers be supplied from a UPS to prevent loss of ILCMS functionality during a power failure.

For the location of the power socket: refer to "Rear View with Connections".

3.1.2 Connection to the Series Circuit

The high-voltage connections "FIELD" and "CCR" (Constant Current Regulator) on the LINC 360Controller are each pre-prepared with cables with a length of 19-in (0.5m), in accordance with the FAA L-824 specification.

The plugs on the built-in cables "CCR" are connected to the sockets on the extension cables going to the CCR. The latter have to be separated in the middle beforehand. The extension cables must be shortened to the appropriate length and mounted on the cabinet terminal strip. From there the connection to the CCR is made.

The connections from the control cabinet to the CCR are to be established on site.

The sockets on the built-in cables "FIELD" are connected with the plugs on the extension cables. The free ends of these extension cables are to be shortened to the appropriate length and mounted on the cabinet terminal strip. From there the connection is established to the series circuit cables, which lead to the airfield.

For the location of the series circuit connectors: refer to “Rear View with Connections”.

3.2 Installation on a Wall

The airflow through the LINC 360 wall mount units is from the bottom to the side to ensure proper cooling and air flow. The devices should be mounted on rails, brackets or tilting racks. They are to be fixed with the 4 clamp bolts positioned on the front.

The ground cables of the LINC 360 Controllers must be connected to the bus bar in the electrical cabinet.

Figure 23: Wall mount diagrams

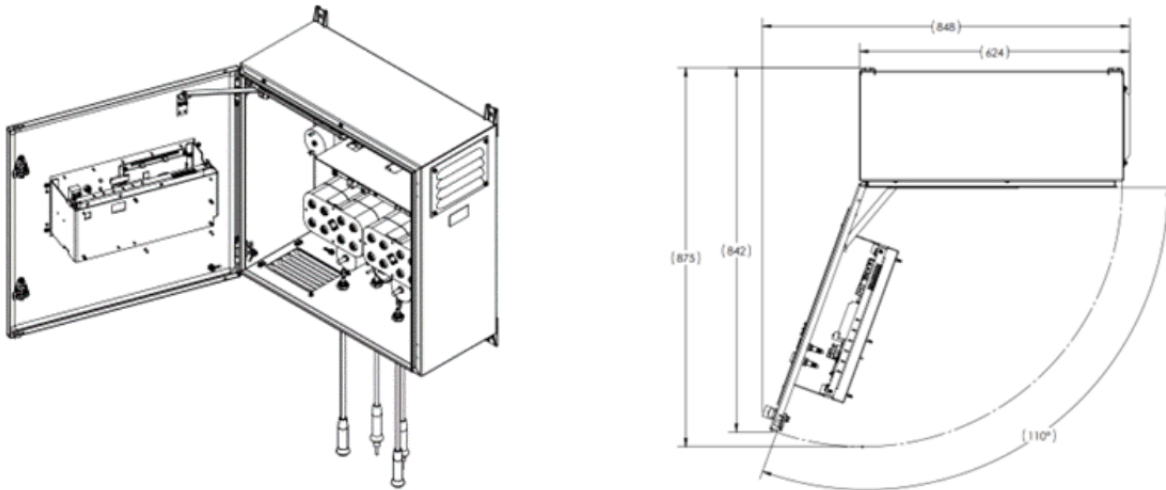

The control cabinet bus bar must be connected by a wire with a minimum cross-sectional area of AWG 0 (50 mm²) to the central earth ground in the control room.

3.3 Connection to the Ethernet Network

Figure 24: Ethernet connections

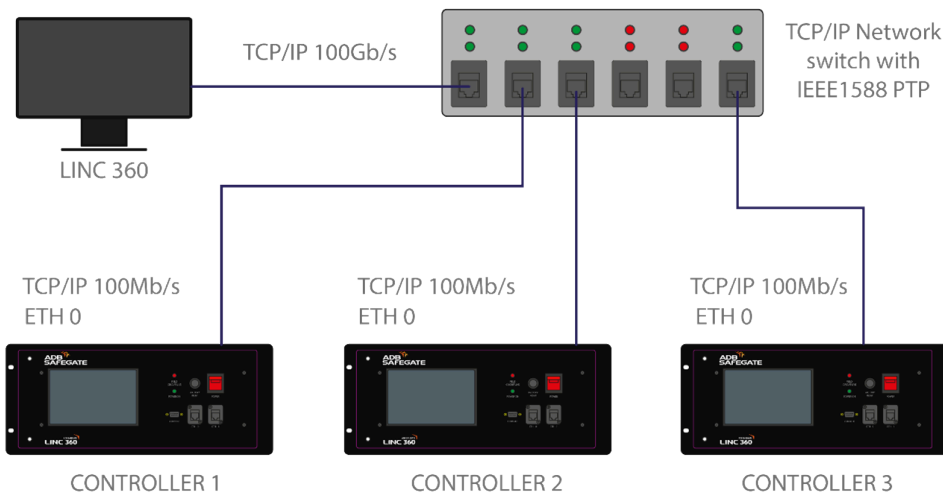

The LINC 360Controller is to be connected via a shielded CAT5 network cable, with RJ45 plugs to the ETH-0 port and the hub or switch of the Ethernet network. The cable is to be run as a 1:1 connection or Eth-1.

The usual segment length restrictions for Ethernet networks apply.

For the location of the Ethernet connectors: refer to “Front View with Control Unit”.

3.4 Earth Grounding

To protect the devices against surges that could be caused by a lightning strike, each LINC 360Controller is to be earth ground separately via the earth ground screw, with minimum induction or resistance. For this an earth ground cable with a suitable cable lug is to be fixed to the earth ground screw on the LINC 360Controller (M6 screw thread). The cross-sectional area of the cable should be at least AWG 8 (6mm²) with a maximum cable length of 39" (1m).

All Controllers ground terminals must be connected to a common earth grounded bar in the vault or substation.

For the location of the earth ground screw: refer to "[Rear View with Connections](#)".

3.5 Safety Instructions



DANGER

WORK ON THE INCOMING POWER SUPPLY SYSTEMS OR THE SERIES CIRCUIT MUST ONLY BE CARRIED OUT BY TRAINED, QUALIFIED STAFF.

FOLLOW THE CURRENTLY APPLICABLE REGULATIONS ACCORDING TO LOCAL AND INTERNATIONAL STANDARDS.



Note

The LINC 360Controller is maintenance free.

The LINC 360Controller may only be opened by authorized maintenance personnel.



WARNING

When working on or carrying out measurements on the device, the following basic rules must be followed:

- The device must be disconnected from the incoming power supply (isolated).
- The device must be secured against being accidentally switched on.
- Disconnection must be measured or checked.

The housing must not be opened until all electrical supply cables have been disconnected for at least 5 minutes. When the housing is open, the incoming power and the high voltage on the series circuit are exposed and freely accessible at various locations. For this reason, work or measurements on the component assemblies are only permitted when there is a second person in the room who will be able to take appropriate action in the event of an accident. Only potential-free instruments may be used for measurements on componentry.

- Components still carry hazardous or deadly voltages even after being switched off.
- ESD susceptible devices (ESDS): Components susceptible to damage by electrostatic discharges
- The component assemblies contain components that are susceptible to electrostatic discharges. These components can be very easily destroyed if not handled properly. However, if it is necessary to work on electronic assemblies, follow the instructions below:
 - Electronic assemblies should only be touched if working on them is absolutely necessary.
 - If assemblies have to be touched, the bodies of those working on them must be discharged to ground immediately prior to contact.
 - Connection pins and printed circuit conductors must not be touched. Assemblies must only be held by the edge.
 - Assemblies may not be brought into contact with highly insulating materials – e.g. plastic parts, insulating table tops, or clothing made of artificial fibers.
 - Assemblies may only be placed on conductive surfaces.
 - Assemblies and components must only be stored or shipped in conductive packaging (such as metallic or metallized plastic containers).
 - If the packaging itself is not conductive, assemblies must be wrapped in a conductive material before packing.

4.0 Connection of LINC 360 to the Airside Cloud

This chapter provides instructions for connecting your LINC 360 Controller to the cloud, enabling seamless data synchronization and telemetry with services such as CORTEX Service (ALIS) or Power BI. Follow these steps carefully to ensure proper configuration and operation.



CAUTION

The circuit needs to be fully configured and commissioned before performing this procedure.

Requirements

Before starting, ensure the following requirements are met:

1. Hardware Requirements:

- a. **Controller:** A LINC 360 controller with a Linux-based control board (Beagle Board with a large LCD screen) or QNX 7.0 or higher (USB).



Note

QNX 6.5 is not supported and requires a hardware upgrade.

- b. **Internet Connection:** Wired internet connection, preferably with a secured gateway. You should be able to set a static IP address on this network. Ensure there is an available Ethernet port for the controller to connect to the internet.

Figure 25: Cloud Connection Options

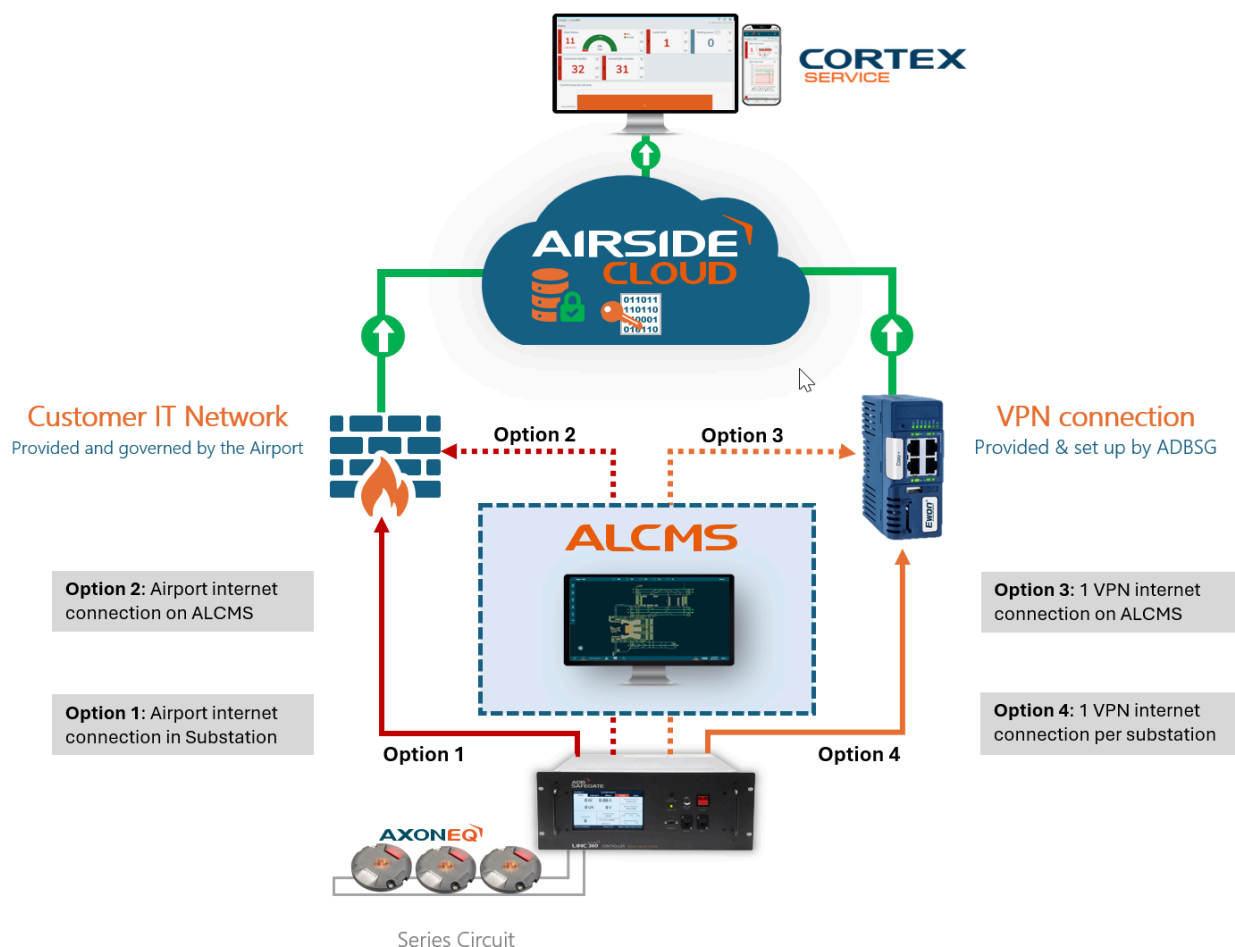

2. **Time Settings:** The controller must be set to UTC (Coordinated Universal Time) or local time and synchronized with an NTP server.
-



WARNING

Incorrect time settings will cause the cloud to reject data.

3. **Configuration Files:** XML configuration files must be updated to include cloud connectivity and telemetry data polling.

4.1 Step-by-Step Instructions

1. Initial Setup

1. Configure your controller and lights in the usual way. Ensure all lights are functional and detected.
2. Verify that your controller firmware and modem firmware meet the required versions:
 - a. Controller Firmware: Version 2.3 or higher. For advanced maintenance package firmware v3.0.0 or higher is required.
 - b. Modem Firmware: Version 2.6 or higher.

If updates are necessary, refer to the firmware update process in PDM or consider swapping the modem hardware.

2. Configure Network Settings

Set the controller's static IP address and ensure the internet gateway is correctly configured. Verify the network availability and internet connection using a computer before proceeding. Test the DNS by pinging **8.8.8.8** into the controller or performing an nslookup on www.adbsafegate.com



Note

"Internet gateway" refers to an airport-provided landline internet or cellular VPN connection, with enabled NTP, MQTT, DNS, HTTP, and HTTPS services enabled through the firewall.

3. XML Configuration for Cloud Connectivity

Adapt the XML configuration file to enable telemetry and cloud connectivity. You should have received a unique **Azure IoT Hub Connection String** from ADB Safegate's Data Team for each connected device (a device is 1 Axon EQ light).

Example:

```
hostName="example.azure-devices.net"
deviceId="example-linc360-device-1"
sharedAccessKey="a_big_cryptic_key"
```



Note

Do not reuse connection strings across devices.

4. Upload Configuration File

Save the XML file and upload it to the controller via the appropriate interface.

5. Enable Smart Settings

- Enable **"Smart" fields** under the "Remotes" section of the controller interface.

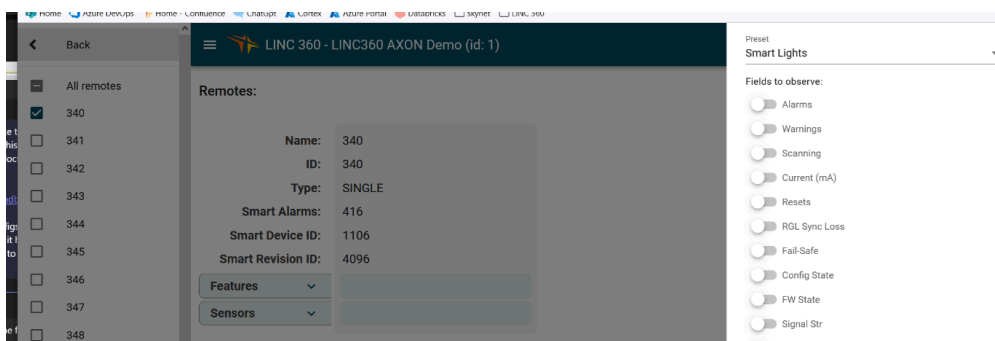

- Ensure telemetry settings are correctly applied to all connected devices.

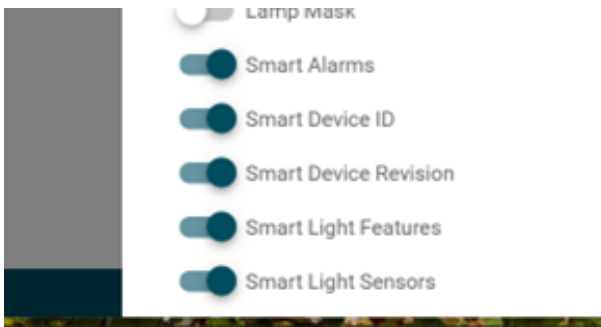

- The additional sensor information fields should be displayed similar to this example:

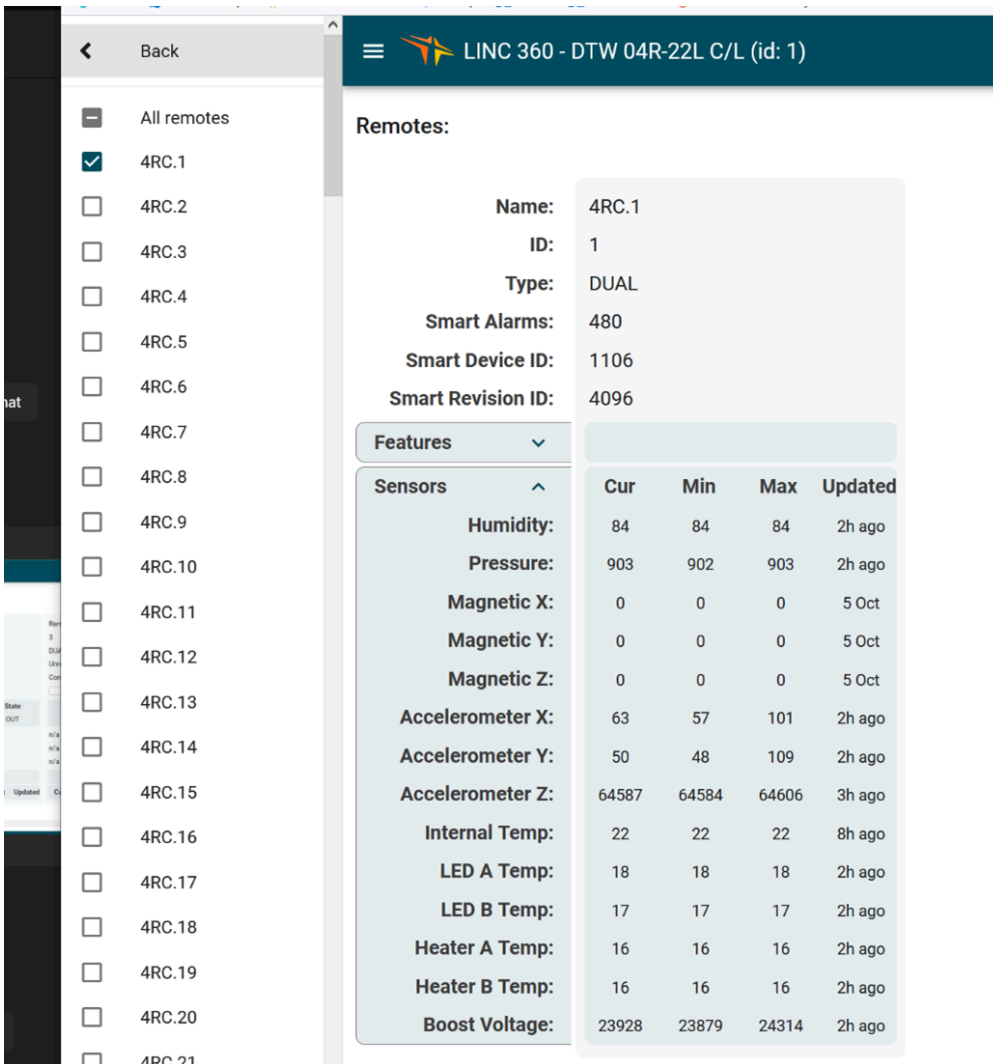

6. Verify Cloud Connectivity

- Once all configurations are complete, you should see a blue cloud icon in the top-right corner of the controller display. This indicates successful data upload to the cloud.
- Test cloud functionality by confirming that telemetry data is accessible in CORTEX Service (ALIS) or Power BI.



Note

For SECOMEA Azure IoT Hub integration, refer to [Getting Started with DCM Azure IoT Hub](#).

>

5.0 Replacing a stand-alone LINC 360Controller

1. Before exchanging a LINC 360Controller, record its technical information.
2. Switch off the LINC 360Controller.
3. Switch off its associated Constant current regulator for the series circuit and disconnect it from the mains power supply by removing the fuses and using the applicable safety protocol (eg. "Lock and tag").
4. Pull out the cut-out for the series circuit, if available. If possible earth ground the series circuit and wait 5 minutes until the circuit is fully discharged.



Note

For all work on the devices, follow the ["Safety Instructions"](#).

5. Switch off any ground fault detection devices (IRMS) which may be connected to this circuit.
6. Removing the LINC 360Controller:

Separate the high-voltage connections "FIELD" and "CCR" on the LINC 360Controller at their cable plug connections and pull the rubber connector out of the *POWER* socket.

Open the ground connection by loosening the nut on the earth ground screw of the LINC 360Controller. Remove connected network links on *Ethernet 0*, and *Ethernet 1*.

Physically remove the LINC 360Controller from the control cabinet.

 - a. Loosen and slide back the top cover of the old Controller.
 - b. Remove the Micro-SD card from the single board computer.
 - c. Loosen and slide back the top cover of the new Controller.
 - d. Swap the Micro-SD card in the new Controller with the one from the old Controller.
7. Install the new LINC 360Controller according to the ["Installation of stand-alone LINC 360 Controllers"](#).

5.1 Wiring Diagram

Figure 26: Wiring Diagram

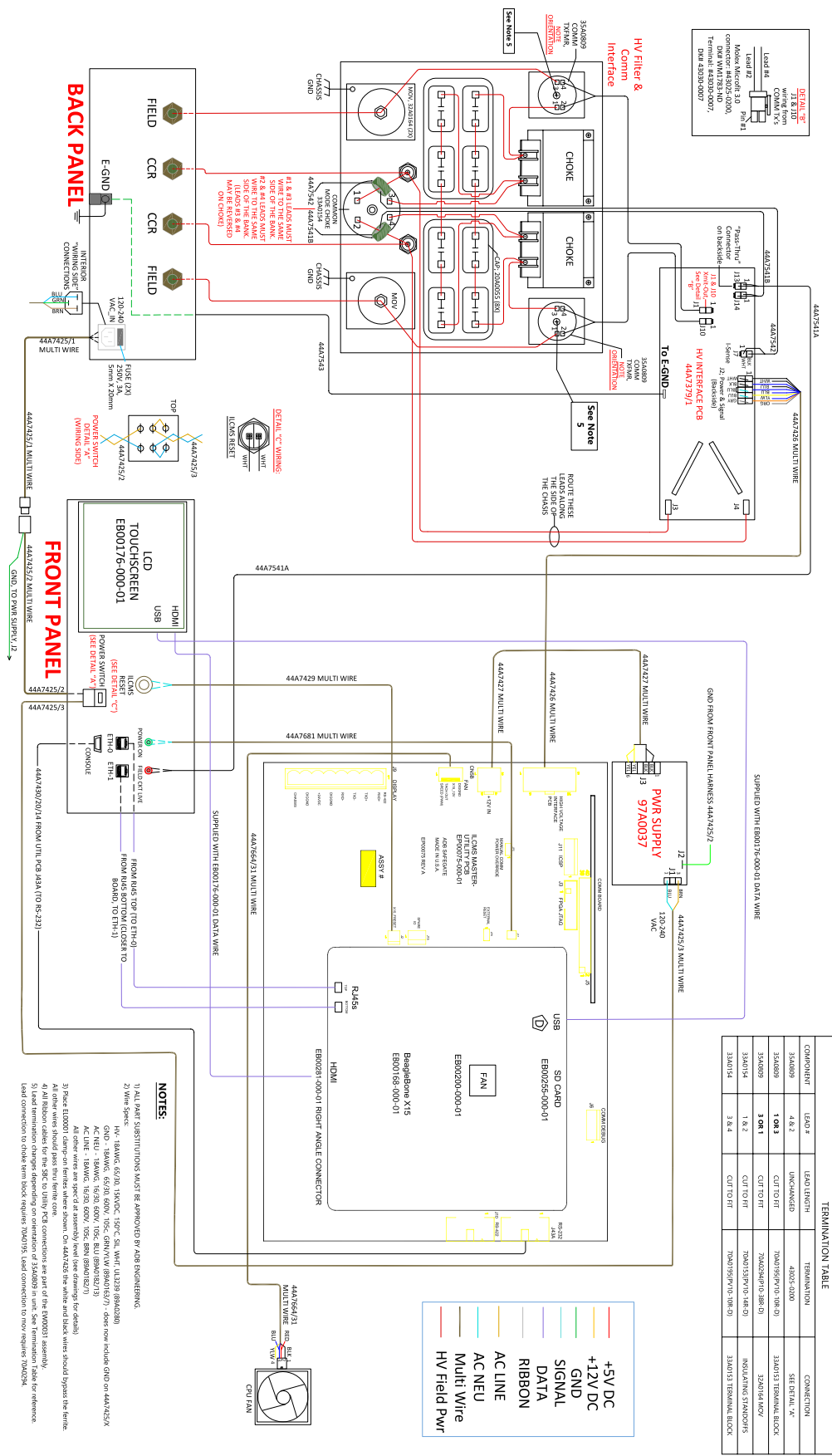

6.0 Parts

Table 4: Ordering Code: Controllers

Description	Part No.
LINC 360 Controller, 19" Rack Mount, EU plug	LINCC00000000101
LINC 360 Controller, Wall Mount, Door Open Left (EU)	LINCC00000000201
LINC 360 Controller, Wall Mount, Door Open Right (EU)	LINCC00000000301
LINC 360 Controller, 19" Rack Mount, US plug	LINCC00000000111
LINC 360 Controller, Wall Mount, Door Open Left (US)	LINCC00000000211
LINC 360 Controller, Wall Mount, Door Open Right (US)	LINCC00000000311
LINC 360 Controller, 19" Rack Mount, UK plug	LINCC00000000121
LINC 360 Controller, Wall Mount, Door Open Left (UK)	LINCC00000000221
LINC 360 Controller, Wall Mount, Door Open Right (UK)	LINCC00000000321
LINC 360 Controller, 19" Compact (no flanges)	LINCC00000000501

Table 5: Ordering Code: Remotes

Description	Part No.
LINC 360 Single Channel Remote, FAA Style 7	AGC4170
LINC 360 Single Channel Remote, FAA Style 8	AGC4180
LINC 360 Single Channel Remote, FAA Style 7, Initial Flash Off	AGC4270
LINC 360 Single Channel Remote, FAA Style 7, Initial Flash On	AGC4370
LINC 360 Dual Channel Remote, FAA Style 7	AGC5170
LINC 360 Dual Channel Remote, FAA Style 7, Channel A Initial Flash On, Channel B Initial Flash Off	AGC5470
LINC 360 Utility Device (Above Ground Installation only)	AGC6110
LINC 360 Power Remote 13.5 Vdc	LINCP00000130001

6.1 Spare Components

Table 6: Ordering Code: Spare Parts

Description	Part No.
GB Industrial Grade Flash Card with Software loaded	AK00048-000-01
LINC 360 Controller Fan Assembly (usb versions with 4-wires)	AS00062-000-01
LINC 360 Controller Touchscreen	EB00274-000-01
Low-voltage PCB Assembly	AS00180-000-01
High-voltage PCB Assembly	44A7379-1
LINC 360/DPS Controller Power Supply	97A0037
LINC 360 Controller Control Module 19" Rack version	SP.AS00182-100-01
LINC 360 Controller Control Module Wall-mount version	SP.AS00182-200-01
DPS Controller Control Module	SP.AS00182-300-01

Appendix A: SUPPORT

Our experienced engineers are available for support and service at all times, 24 hour/7 days a week. They are part of a dynamic organization making sure the entire ADB SAFEGATE is committed to minimal disturbance for airport operations.

ADB SAFEGATE Support

Technical Support – Global

Customers in Europe, the Middle East, Africa or Asia Pacific are more than welcome to our portal for technical support. Trained in all areas of system issues, troubleshooting, quality control and technical assistance, our highly experienced Technical support specialists are available 24 hours a day, seven days a week to provide assistance over the phone. In the Americas, we also offer live technical support.

Live Technical Support – Americas

If at any time you have a question or concern about your product, contact ADB SAFEGATE's US-based technical support specialists, available 24 hours a day, seven days a week, to assist you via phone.

ADB SAFEGATE Americas Technical Service & Support (US & Canada) :+1-800-545-4157

ADB SAFEGATE Americas Technical Service & Support (Canada): +1-905-631-1597

ADB SAFEGATE Americas Technical Service & Support (International): +1-614-861-1304

We can also be reached via email during regular business hours:

Airfield and Gate: techservice.us@adbsafegate.com

Gate: gateservice.us@adbsafegate.com

We look forward to working with you!

Before You Call

When you have an airfield lighting or system control system problem, prior to calling, please ensure the following:

- Review the product's manual and troubleshooting guide.
- Be located with the product ready to troubleshoot.
- Have all necessary information available: airport code/company name, customer id number, contact phone number/email address, product/part number.
- Have a True RMS meter available and any other necessary tools.

When calling about an issue with Safedock A-VDGS, we can serve you better if you collect the following information before you call:

- Relevant information regarding the issue you are calling about, such as gate number, flight number, aircraft type and time of the event.
- What, if any, actions have been taken to resolve the issue prior to the call.
- If available, provide a CCTV recording of the incident to aid in aligning the information from the Safedock log file.



Note

For more information, see www.adbsafegate.com, contact ADB SAFEGATE Support via email at support@adbsafegate.com or Europe: +32 2 722 17 11

Americas: +1 614 861 1304. Press 3 for technical service or press 4 for sales support.

China: +86 (10) 8476 0106

Middle East and Africa: +971 4 452 7575

A.1 ADB SAFEGATE Website

The ADB SAFEGATE website, www.adbsafegate.com, offers information regarding our airport solutions, products, company, news, links, downloads, references, contacts and more.

A.2 Recycling

A.2.1 Local Authority Recycling

The disposal of ADB SAFEGATE products is to be made at an applicable collection point for the recycling of electrical and electronic equipment. The correct disposal of equipment prevents any potential negative consequences for the environment and human health, which could otherwise be caused by inappropriate waste handling. The recycling of materials helps to conserve natural resources. For more detailed information about recycling of products, contact your local authority city office.

A.2.2 ADB SAFEGATE Recycling

ADB SAFEGATE is fully committed to environmentally-conscious manufacturing with strict monitoring of our own processes as well as supplier components and sub-contractor operations. ADB SAFEGATE offers a recycling program for our products to all customers worldwide, whether or not the products were sold within the EU.

ADB SAFEGATE products and/or specific electrical and electronic component parts which are fully removed/separated from any customer equipment and returned will be accepted for our recycling program.

All items returned must be clearly labeled as follows:

- For RoHS/WEEE Recycling
- Sender contact information (Name, Business Address, Phone number).
- Main Unit Serial Number.

ADB SAFEGATE will continue to monitor and update according for any future requirements for EU directives as and when EU member states implement new regulations and or amendments. It is our aim to maintain our compliance plan and assist our customers.

Company Addresses

ADB SAFEGATE, Belgium	ADB SAFEGATE BV Leuvensesteenweg 585 B-1930 Zaventem Belgium
Contact:	
Tel.: +32 2 722 17 11	Email: marketing@adbsafegate.com
Fax: +32 2 722 17 64	Internet: www.adbsafegate.com
ADB SAFEGATE, Americas	ADB SAFEGATE Americas, LLC 700 Science Blvd Gahanna, OH 43230 USA
Contact:	
Tel.: +1 (614) 861 1304	Email: sales.us@adbsafegate.com
Fax: +1 (614) 864 2069	Internet: www.adbsafegate.com
ADB SAFEGATE, Sweden	ADB SAFEGATE Sweden AB Djurhagegatan 19 SE-213 76 Malmö Sweden
Contact:	
Tel.: +46 (0)40 699 17 00	Email: marketing@adbsafegate.com
Fax: +46 (0)40 699 17 30	Internet: www.adbsafegate.com
ADB SAFEGATE, China	ADB SAFEGATE Airfield Technologies Ltd. China Unit 603, D Block, CAMIC International Convention Center, No 3, Hua Jia Di East road, ChaoYang district, Beijing 100102 P.R. China
Contact:	
Tel.: +86 (10) 8476 0106	Email: china@safegate.com
Fax: +86 (10) 8476 0090	Internet: www.adbsafegate.com
ADB SAFEGATE, Germany	ADB SAFEGATE Germany GmbH Konrad-Zuse-Ring 6, D-68163 Mannheim Germany
Contact:	
Tel.: +49 (621) 87 55 76-0	Email: marketing@adbsafegate.com
Fax: +49 (621) 87 55 76-55	Internet: www.adbsafegate.com

WWW.ADBSAFEGATE.COM

Empowering the Airside **Evolution**

SMARTER. BETTER. **NOW.**

