



Inset Flashing Light Type FFL
for use in flashing systems

User Manual

UM-4021 / AM02-620_2e, Rev. 3.1.3, 2025/04/17

**ADB
SAFEGATE**

A.0 Disclaimer / Standard Warranty

CE certification

The equipment listed as CE certified means that the product complies with the essential requirements concerning safety and hygiene. The European directives that have been taken into consideration in the design are available on written request to ADB SAFEGATE.

ETL certification

The equipment listed as ETL certified means that the product complies with the essential requirements concerning safety and C22.2 No.180:13 (R2018) regulations. The CSA directives that have been taken into consideration in the design are available on written request to ADB SAFEGATE.

All Products Guarantee

ADB SAFEGATE will correct by repair or replacement per the applicable guarantee below, at its option, equipment or parts which fail because of mechanical, electrical or physical defects, provided that the goods have been properly handled and stored prior to installation, properly installed and properly operated after installation, and provided further that Buyer gives ADB SAFEGATE written notice of such defects after delivery of the goods to Buyer. Refer to the Safety section for more information on Material Handling Precautions and Storage precautions that must be followed.

ADB SAFEGATE reserves the right to examine goods upon which a claim is made. Said goods must be presented in the same condition as when the defect therein was discovered. ADB SAFEGATE further reserves the right to require the return of such goods to establish any claim.

ADB SAFEGATE's obligation under this guarantee is limited to making repair or replacement within a reasonable time after receipt of such written notice and does not include any other costs such as the cost of removal of defective part, installation of repaired product, labor or consequential damages of any kind, the exclusive remedy being to require such new parts to be furnished.

ADB SAFEGATE's liability under no circumstances will exceed the contract price of goods claimed to be defective. Any returns under this guarantee are to be on a transportation charges prepaid basis. For products not manufactured by, but sold by ADB SAFEGATE, warranty is limited to that extended by the original manufacturer. This is ADB SAFEGATE's sole guarantee and warranty with respect to the goods; there are no express warranties or warranties of fitness for any particular purpose or any implied warranties of fitness for any particular purpose or any implied warranties other than those made expressly herein. All such warranties being expressly disclaimed.

Standard Products Guarantee

Products manufactured by ADB SAFEGATE are guaranteed against mechanical, electrical, and physical defects (excluding lamps) which may occur during proper and normal use for a period of two years from the date of ex-works delivery, and are guaranteed to be merchantable and fit for the ordinary purposes for which such products are made.



Note

See your applicable sales agreement for a complete warranty description.

Replaced or repaired equipment under warranty falls into the warranty of the original delivery. No new warranty period is started for these replaced or repaired products.

FAA Certified products manufactured by ADB SAFEGATE

ADB SAFEGATE L858 Airfield Guidance Signs are warranted against mechanical and physical defects in design or manufacture for a period of 2 years from date of installation, per FAA AC 150/5345-44 (applicable edition).

ADB SAFEGATE LED products (with the exception of obstruction lighting) are warranted against electrical defects in design or manufacture of the LED or LED specific circuitry for a period of 4 years from date of installation, per FAA EB67 (applicable edition). These FAA certified constant current (series) powered LED products must be installed, interfaced and powered with and through products certified under the FAA Airfield Lighting Equipment Program (ALECP) to be included in this 4 (four) year warranty. This includes, but is not limited to, interface with products such as Base Cans, Isolation Transformers, Connectors, Wiring, and Constant Current Regulators.



Note

See your sales order contract for a complete warranty description.

Replaced or repaired equipment under warranty falls into the warranty of the original delivery. No new warranty period is started for these replaced or repaired products.

Liability



WARNING

Use of the equipment in ways other than described in the catalog leaflet and the manual may result in personal injury, death, or property and equipment damage. Use this equipment only as described in the manual.

ADB SAFEGATE cannot be held responsible for injuries or damages resulting from non-standard, unintended uses of its equipment. The equipment is designed and intended only for the purpose described in the manual. Uses not described in the manual are considered unintended uses and may result in serious personal injury, death or property damage.

Unintended uses, includes the following actions:

- Making changes to equipment that have not been recommended or described in this manual or using parts that are not genuine ADB SAFEGATE replacement parts or accessories.
- Failing to make sure that auxiliary equipment complies with approval agency requirements, local codes, and all applicable safety standards if not in contradiction with the general rules.
- Using materials or auxiliary equipment that are inappropriate or incompatible with your ADB SAFEGATE equipment.
- Allowing unskilled personnel to perform any task on or with the equipment.

Copyright Statement

This manual or parts thereof may not be reproduced, stored in a retrieval system, or transmitted, in any form or by any means, electronic, mechanical, photocopying, recording, nor otherwise, without the author's prior written consent.

This manual could contain technical inaccuracies or typographical errors. The author reserves the right to revise this manual from time to time in the contents thereof without obligation of the author to notify any person of such revision or change. Details and values given in this manual are average values and have been compiled with care. They are not binding, however, and the author disclaims any liability for damages or detriments suffered as a result of reliance on the information given herein or the use of products, processes or equipment to which this manual refers. No warranty is made that the use of the information or of the products, processes or equipment to which this manual refers will not infringe any third party's patents or rights. The information given does not release the buyer from making their own experiments and tests.

TABLE OF CONTENTS

1.0 Safety	1
1.1 Safety Messages	1
1.1.1 Introduction to Safety	2
1.1.2 Intended Use	2
1.1.3 Material Handling Precautions: Storage	3
1.1.4 Material Handling: Heavy Equipment	3
1.1.5 Material Handling Precautions: Fasteners	3
1.1.6 Operation Safety	4
1.1.7 Maintenance Safety	4
1.1.8 Material Handling Precautions, ESD	5
1.1.9 Arc Flash and Electric Shock Hazard	5
2.0 About this Manual	7
3.0 Introduction	9
3.1 General information	9
3.1.1 12-inch FFL inset flashing lights	9
3.2 Product data	9
3.2.1 Equipment supplied	9
3.2.2 References	9
3.2.3 Equipment required for installation and maintenance	9
4.0 Installation	11
4.1 Introduction	11
4.2 Important safety notifications	11
4.2.1 Fixing hardware	11
4.3 General recommendations	11
4.3.1 Receiving, storage and unpacking	11
4.3.2 Electrical connection	12
4.3.3 Base Earthing	12
4.3.4 Location and tolerances	12
4.4 How to connect the receptacle	12
4.5 How to mount the light on the base or adapter ring and connect it	13
4.5.1 Before you start	13
4.5.2 Use the correct fixing hardware	13
4.5.3 How to mount the light assembly	13
4.6 Installation of adapter ring	14
4.6.1 Adapter ring installation	14
5.0 Maintenance	15
5.1 Introduction	15
5.2 Workshop maintenance and preventive maintenance	15
5.2.1 In the field maintenance	15
5.2.2 Preventive maintenance	15
5.2.3 Preventive maintenance tasks	16
5.3 How to lift the light fixture out of the base or adapter ring	16
5.3.1 Lifting tool	16
5.3.2 Procedure	17
6.0 Servicing in the Maintenance base	19
6.1 Introduction	19
6.2 How to open the light assembly	19
6.2.1 Procedure	19
6.3 How to replace the lamp	20
6.3.1 Procedure	20
6.4 How to replace the prism	21
6.4.1 Procedure	21

6.5 How to replace the trigger PCB	21
6.5.1 Former version	21
6.5.2 Procedure	21
6.6 How to replace the lamp PCB	22
6.6.1 Former version	22
6.6.2 Procedure	22
6.7 How to replace the cable set assembly	23
6.7.1 Cable sets	23
6.7.2 Procedure	23
6.8 How to close and test the light fixture	24
6.8.1 Procedure	24
7.0 Troubleshooting	27
8.0 Ordering Codes and Exploded View	29
8.1 Introduction	29
8.2 Complete Products and Spare Parts	29
8.2.1 Spare Parts	29
8.2.2 FFL Fixtures and Shallow Bases	29
8.2.3 Fixing hardware kits	30
8.2.4 FFL Parts	32
8.3 Screws Overview	33
8.4 Exploded view	34
8.5 Accessories	35
8.5.1 Tool case	35
8.5.2 Additional accessories	35
A.0 SUPPORT	37
A.1 ADB SAFEGATE Website	38
A.2 Recycling	38
A.2.1 Local Authority Recycling	38
A.2.2 ADB SAFEGATE Recycling	38

List of Tables

Table 1: Fixing hardware kits of F-Range inset lights 30

1.0 Safety

Introduction to Safety

This section contains general safety instructions for installing and using ADB SAFEGATE equipment. Some safety instructions may not apply to the equipment in this manual. Task- and equipment-specific warnings are included in other sections of this manual where appropriate.

1.1 Safety Messages

HAZARD Icons used in the manual

For all HAZARD symbols in use, see the Safety section. All symbols must comply with ISO and ANSI standards.

Carefully read and observe all safety instructions in this manual, which alert you to safety hazards and conditions that may result in personal injury, death or property and equipment damage and are accompanied by the symbol shown below.



WARNING

Failure to observe a warning may result in personal injury, death or equipment damage.



DANGER – Risk of electrical shock or ARC FLASH

Disconnect equipment from line voltage. Failure to observe this warning may result in personal injury, death, or equipment damage. ARC Flash may cause blindness, severe burns or death.



WARNING – Wear personal protective equipment

Failure to observe may result in serious injury.



WARNING – Do not touch

Failure to observe this warning may result in personal injury, death, or equipment damage.



CAUTION

Failure to observe a caution may result in equipment damage.



ELECTROSTATIC SENSITIVE DEVICES

This equipment may contain electrostatic devices.

Qualified Personnel



Important Information

The term **qualified personnel** is defined here as individuals who thoroughly understand the equipment and its safe operation, maintenance and repair. Qualified personnel are physically capable of performing the required tasks, familiar with all relevant safety rules and regulations and have been trained to safely install, operate, maintain and repair the equipment. It is the responsibility of the company operating this equipment to ensure that its personnel meet these requirements.

Always use required personal protective equipment (PPE) and follow safe electrical work practice.

1.1.1 Introduction to Safety



CAUTION

Unsafe Equipment Use

This equipment may contain electrostatic devices, hazardous voltages and sharp edges on components

- Read installation instructions in their entirety before starting installation.
- Become familiar with the general safety instructions in this section of the manual before installing, operating, maintaining or repairing this equipment.
- Read and carefully follow the instructions throughout this manual for performing specific tasks and working with specific equipment.
- Make this manual available to personnel installing, operating, maintaining or repairing this equipment.
- Follow all applicable safety procedures required by your company, industry standards and government or other regulatory agencies.
- Install all electrical connections to local code.
- Use only electrical wire of sufficient gauge and insulation to handle the rated current demand. All wiring must meet local codes.
- Route electrical wiring along a protected path. Make sure they will not be damaged by moving equipment.
- Protect components from damage, wear, and harsh environment conditions.
- Allow ample room for maintenance, panel accessibility, and cover removal.
- Protect equipment with safety devices as specified by applicable safety regulations
- If safety devices must be removed for installation, install them immediately after the work is completed and check them for proper functioning prior to returning power to the circuit.

Failure to follow this instruction can result in serious injury or equipment damage

Additional Reference Materials



Important Information

- IEC – International Standards and Conformity Assessment for all electrical, electronic and related technologies.
- IEC 60364 – Electrical Installations in Buildings.
- CSA – C22.2 No.180:13 (R2018), series isolating transformers for airport lighting.
- FAA Advisory: AC 150/5340-26 (current edition), Maintenance of Airport Visual Aid Facilities.
- Maintenance personnel must refer to the maintenance procedure described in the ICAO Airport Services Manual, Part 9.
- ANSI/NFPA 79, Electrical Standards for Metalworking Machine Tools.
- National and local electrical codes and standards.

1.1.2 Intended Use



CAUTION

Use this equipment as intended by the manufacturer

This equipment is designed to perform a specific function, do not use this equipment for other purposes

- Using this equipment in ways other than described in this manual may result in personal injury, death or property and equipment damage. Use this equipment only as described in this manual.

Failure to follow this instruction can result in serious injury or equipment damage

1.1.3 Material Handling Precautions: Storage



CAUTION

Improper Storage

Store this equipment properly

- If equipment is to be stored prior to installation, it must be protected from the weather and kept free of condensation and dust.

Failure to follow this instruction can result in equipment damage

1.1.4 Material Handling: Heavy Equipment



DANGER

Unstable load

Use caution when moving heavy equipment

- Use extreme care when moving heavy equipment.
- Verify that the moving equipment is rated to handle the weight.
- When removing equipment from a shipping pallet, carefully balance and secure it using a safety strap.

Failure to follow this instruction can result in death, serious injury, or equipment damage

1.1.5 Material Handling Precautions: Fasteners



DANGER

Foreign Object Damage - FOD

This equipment may contain fasteners that may come loose - torque properly.

- Only use fasteners of the same type as the one originally supplied with the equipment.
- Use of incorrect combination of gaskets, bolts and nuts can create severe damages to the product installation and create safety risk .
- You need to know what base the light fixture will be installed in, in order to chose the correct gasket, bolts and nuts.
- Bolt type, length, and torque value are determined by type of base, height of spacers used, and clamp force required in FAA Engineering Brief No 83 (latest revision).
- Due to the risk of bolts vibrating loose, do not use any type of washer with the fixing bolts (such as split lock washers) other than an anti-vibration washer. Anti-vibration washers as defined in FAA EB 83 (latest edition) must be used. For installations other than FAA, use the base can manufacturer's recommendations.
- Always tighten the fasteners to the recommended torque. Use a calibrated torque wrench and apply the recommended adhesive type.
- Obey the instructions of the adhesives necessary for the fasteners.

Failure to follow these warnings may cause the fasteners to loosen, damage the equipment, potentially to loosen the equipment. This can lead to a highly dangerous situation of FOD, with potential lethal consequences.



Note

To minimize the risk of errors, the ADB SAFEGATE Sales Representative will have information on which gasket goes with which base. This information is also provided in the product Data sheets, the User Manuals and the Spare Part Lists.



CAUTION

Use of incorrect combination of gaskets, bolts and nuts can create severe damages to the product installation and create multiple safety risks.

To obtain a safe and watertight installation the O-ring and retaining bolt stated in the document must be used.

You need to know what base the light fixture will be installed in, in order to choose the correct gasket, bolts and nuts.

Failure to follow these cautions can result in equipment damage or aircraft FOD.

1.1.6 Operation Safety



CAUTION

Improper Operation

Do Not Operate this equipment other than as specified by the manufacturer

- Only qualified personnel, physically capable of operating the equipment and with no impairments in their judgment or reaction times, should operate this equipment.
- Read all system component manuals before operating this equipment. A thorough understanding of system components and their operation will help you operate the system safely and efficiently.
- Before starting this equipment, check all safety interlocks, fire-detection systems, and protective devices such as panels and covers. Make sure all devices are fully functional. Do not operate the system if these devices are not working properly. Do not deactivate or bypass automatic safety interlocks or locked-out electrical disconnects or pneumatic valves.
- Protect equipment with safety devices as specified by applicable safety regulations.
- If safety devices must be removed for installation, install them immediately after the work is completed and check them for proper functioning.
- Route electrical wiring along a protected path. Make sure they will not be damaged by moving equipment.
- Never operate equipment with a known malfunction.
- Do not attempt to operate or service electrical equipment if standing water is present.
- Use this equipment only in the environments for which it is rated. Do not operate this equipment in humid, flammable, or explosive environments unless it has been rated for safe operation in these environments.
- Never touch exposed electrical connections on equipment while the power is ON.

Failure to follow these instructions can result in equipment damage

1.1.7 Maintenance Safety



DANGER

Electric Shock Hazard

This equipment may contain electrostatic devices

- Do not operate a system that contains malfunctioning components. If a component malfunctions, turn the system OFF immediately.
- Disconnect and lock out electrical power.
- Allow only qualified personnel to make repairs. Repair or replace the malfunctioning component according to instructions provided in its manual.

Failure to follow these instructions can result in death or equipment damage

1.1.8 Material Handling Precautions, ESD



CAUTION

Electrostatic Sensitive Devices

This equipment may contain electrostatic devices

- Protect from electrostatic discharge.
- Electronic modules and components should be touched only when this is unavoidable e.g. soldering, replacement.
- Before touching any component of the cabinet you shall bring your body to the same potential as the cabinet by touching a conductive earthed part of the cabinet.
- Electronic modules or components must not be brought in contact with highly insulating materials such as plastic sheets, synthetic fiber clothing. They must be laid down on conductive surfaces.
- The tip of the soldering iron must be grounded.
- Electronic modules and components must be stored and transported in conductive packing.

Failure to follow this instruction can result in equipment damage

1.1.9 Arc Flash and Electric Shock Hazard



DANGER

Series Circuits have Hazardous Voltages

This equipment produces high voltages to maintain the specified current - Do NOT Disconnect while energized.

- Allow only qualified personnel to perform maintenance, troubleshooting, and repair tasks.
- Only persons who are properly trained and familiar with ADB SAFEGATE equipment are permitted to service this equipment.
- An open airfield current circuit is capable of generating >5000 Vac and may appear OFF to a meter.
- Never unplug a device from a constant current circuit while it is operating; Arc flash may result.
- Disconnect and lock out electrical power.
- Always use safety devices when working on this equipment.
- Follow the recommended maintenance procedures in the product manuals.
- Do not service or adjust any equipment unless another person trained in first aid and CPR is present.
- Connect all disconnected equipment ground cables and wires after servicing equipment. Ground all conductive equipment.
- Use only approved ADB SAFEGATE replacement parts. Using unapproved parts or making unapproved modifications to equipment may void agency approvals and create safety hazards.
- Check the interlock systems periodically to ensure their effectiveness.
- Do not attempt to service electrical equipment if standing water is present. Use caution when servicing electrical equipment in a high-humidity environment.
- Use tools with insulated handles when working with airfield electrical equipment.

Failure to follow these instructions can result in death or equipment damage

2.0 About this Manual

This manual describes the procedures for the installation, maintenance and troubleshooting of the ADB SAFEGATE 12-inch flashing inset light FFL.

This manual covers the light fixtures manufactured in accordance with FAA specification E-2628b and E-2689a for the photometric, electrical and mechanical strength requirements.

Operation beyond the limitations mentioned in those specifications may result in degradation of performance, damage or failure of components or hazardous conditions.

For more information, see www.adbsafegate.com.

3.0 Introduction

In this chapter you will find all the information about the shipment and the identification of the ADB SAFEGATE 12-inch FFL F-Range inset flashing light.

3.1 General information

3.1.1 12-inch FFL inset flashing lights

The ADB SAFEGATE 12-inch flashing inset lights are the ideal complement to the UEL elevated flashing light in a SFL or RT(E)ILS system controlled via FCU control cabinets. The light fixtures provide optimum visual guidance with minimal maintenance, low life-cycle costs and maximum reliability. They are designed to withstand the high impact and roll-over loads imposed by today's widebody aircraft during landing and take-off operations while remaining waterproof and serviceable.



Note

The fixtures are shipped ready for installation on an adapted ADB SAFEGATE 12-inch shallow base (Eurobase[®]) or on FAA deep bases type L 868-B or LB 4 with an adapter ring. See Table 1 for the reference of the shallow base and of the special 5-pole receptacle required for connection from the FCU cabinet.

3.2 Product data

3.2.1 Equipment supplied

Each unit is supplied completely assembled, tested and sealed, ready for installation. The electrical connection is made via a 5-pole plug cable assembly.

Each unit is individually packed in a durable, cushioned and corrugated cardboard box, labeled with ADB SAFEGATE and ordering numbers.

At least one instruction manual is delivered per order.

3.2.2 References



Note

For ordering codes and reference data pertinent to the light fixture and its components, see § [Ordering Codes and Exploded View](#) .

3.2.3 Equipment required for installation and maintenance

In addition to the light itself, some equipment is required for installation and maintenance.

This equipment is not supplied with the light but can be purchased from ADB SAFEGATE. Our local representatives will be glad to assist you.

For references of the installation and maintenance equipment, see § [Accessories](#) .

4.0 Installation

4.1 Introduction

This chapter describes how to install the FFL light on its base or adapter ring.

It includes important safety notifications regarding the choice and use of fixing hardware.

Specific instructions for the installation of the receptacle connector in the base are also given here below.



Note

It is supposed that the base supporting the 12-inch F-Range inset light and the secondary connector(s) are already installed. All information pertinent to the installation of bases is available in the instruction manual Am.05.120.

4.2 Important safety notifications

4.2.1 Fixing hardware

Various types of fixing hardware can be used for the fixation of the light on its base or adapter ring (e.g. screws or studs and nuts). Moreover, bases and adapter rings may be supplied with threaded holes according either to ISO metric or UNC standards.



WARNING

Only use fixing hardware of the same type as the one originally supplied with the base or adapter ring!

Always tighten the fixing hardware to the recommended torque, using a calibrated torque wrench and applying the recommended type of sealant!

For the tool to use, the requirement for use of Loctite and the torque to apply, see § [How to mount the light on the base or adapter ring and connect it](#),

It is possible to insert a 3/8-inch-16 UNC screw in a M10 threaded hole. However, such a combination damages the female thread and does not ensure a correct fastening so that the screw could become loose under repeated operation of rolling aircraft. Using screws of incorrect standard might lead to either damage to the thread in the base or to an incorrect fixation of the lights.

Generally, using fixing hardware of a different type of the one originally supplied with the bases or adapter rings, or tightening it at an incorrect torque, may lead to a loosening of the fixing hardware, damage to the light and base, and potentially to the separation of the light fitting or parts thereof from its base. This can lead to a highly dangerous situation of Foreign Object Debris (FOD), with potential lethal consequences.

4.3 General recommendations

4.3.1 Receiving, storage and unpacking

1. Upon receipt of goods at the site store, check all packages for visible damage. Every damaged box should be opened and its content inspected for damage.



Note

If equipment is damaged, a claim form shall be filed with the carrier immediately. It may then be necessary for the carrier to inspect the equipment.

2. Store the light assembly preferably in its original packing in a protected area. When stored unpacked, please take care not to damage the cable insulation.
3. Unpack the light assembly at the installation site to avoid damage during transportation and handling.

4.3.2 Electrical connection

The light assemblies covered by this manual are designed for connection to FCU flashing cabinets through a 5-pole connector supplied with the light.

Refer to ADB SAFEGATE user manual UM-4020_AM.02.620 for more information on the type of cable to use and on how to connect the cable to the FCU cabinet.

A 5-pole receptacle (see § Complete Products and Spare Parts) is required for the connection of the cable from the FCU in the base.

4.3.3 Base Earthing

Whatever the chosen installation method, it is strongly recommended to earth the base, especially in locations presenting a risk of lightning strikes.

Failure to earth correctly the base will void the warranty for all damages occurring as a result of voltage surges.



Note

Guidelines on how to realize the earthing of the base are given in instruction manual Am05.120

4.3.4 Location and tolerances

The applicable documents for location details and tolerances are the following:

Organization	Applicable documents
ICAO	Annex 14
	Aerodrome Design Manual Part 4
FAA	Advisory Circular AC no. 150/5340-28

4.4 How to connect the receptacle

The receptacle must be connected to the cable coming from the FCU cabinet, respecting the polarities of the drawing below:

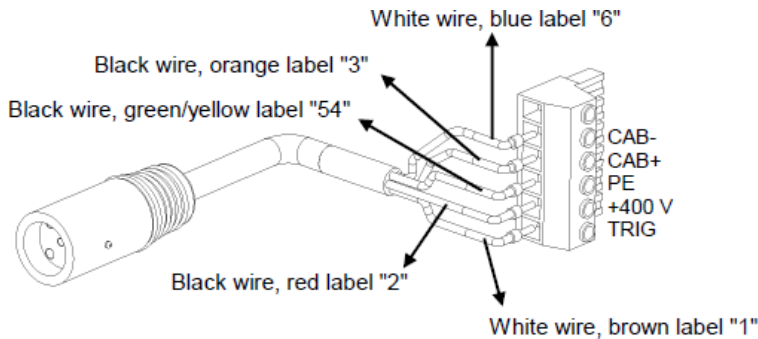

4.5 How to mount the light on the base or adapter ring and connect it

4.5.1 Before you start

Make sure that the contact surfaces of the light assembly with base and the gaskets are absolutely clean and smooth.

4.5.2 Use the correct fixing hardware

Please refer to the § [Important safety notifications](#) : Only use fixing hardware of the same type as the one originally supplied with the base or adapter ring!

In ADB SAFEGATE shallow bases delivered since mid-2006, the type of thread is indicated on the bottom or the flange of the base: METRIC M10 or 3/8-inch-16UNC.

How to be sure of the type of fixing hardware you are using?

- M10 screws require the use of a 17 mm socket
- 3/8-inch-16UNC screws require a 9/16-inch socket, this is approximately 14.3 mm



WARNING

On a base or adapter ring with metric M10 female thread, never use a screw that can be fastened with a socket smaller than 17 mm: it would indicate that you are inserting a 3/8-inch-16UNC screw in a M10 female thread.

The opposite – inserting a M10 screw in a 3/8-inch-16UNC female thread – is impossible.

4.5.3 How to mount the light assembly

To mount and connect the light assembly, proceed as follows:

1. In case a light has already been mounted on the base, remnants of Loctite are present in the fixation holes. Clean them using a cleaning tap for blind holes (preferably use a tap with a right spiral groove) and blow with dry, oil-free compressed air.
2. Apply a light coat of neutral vacuum type silicone grease (PN 7850.42.220) to a new, clean O-ring gasket (D2).
3. Place the O-ring carefully in its groove.



CAUTION

Never reuse an already used gasket.

4. Connect the 5-pole plug with the 5-pole receptacle, already installed in the base
5. Apply Loctite on the three first threads of the threaded holes in the base.



CAUTION

Always use Loctite 2701 to fasten the light fixture on its support.

6. Gently install the light fixture in the base.

If using a lifting device, see § [How to lift the light fixture out of the base or adapter ring](#)



CAUTION

Pay attention not to pinch the cable between fitting and (shallow) base.

7. Make sure that the washers are mounted correctly – dents facing upwards – to avoid denting the cover.

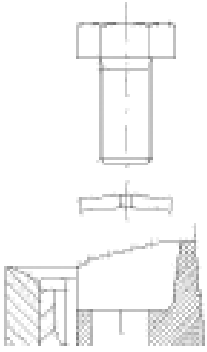

8. Torque down gradually and crosswise the 6 screws and washers (A1- A2) or self locking nuts.
-



CAUTION

Make sure the screws are tightened with a torque of 21 Nm/190 Lb.in.

4.6 Installation of adapter ring

4.6.1 Adapter ring installation

To install the adapter ring, proceed as follow:

1. Clean the contact surfaces of the deep base and adapter ring.
In case an adapter ring has already been mounted on the base, remnants of Loctite are present in the fixation holes. Clean them using a cleaning tap for blind holes (preferably use a tap with a right spiral groove) and blow with dry, oil-free compressed air.
 2. Put onto the contact layer of the base a layer of RTV106 (NC 7835.55.151) or equivalent.
 3. Apply Loctite on the three first threads of the threaded holes in the base.
-



CAUTION

Always use Loctite 2701 to fasten the adapter ring on its support.

4. Mount the adapter ring onto the base and torque down the fixation screws.
-



CAUTION

Make sure the screws are tightened with a torque of 21 Nm/190 Lb.in.

5. Install the light as described above.

5.0 Maintenance

5.1 Introduction

This chapter describes general ideas on workshop maintenance and preventive maintenance and you will learn how to lift the unit out of the base or adapter ring.

For detailed description of the servicing of the light assembly in the maintenance workshop, see § [Servicing in the Maintenance base](#) .

5.2 Workshop maintenance and preventive maintenance

5.2.1 In the field maintenance

The light assemblies can be serviced in the field, but it is recommended to limit field maintenance to cleaning the prisms. It is recommended to replace the inset lights preventively at regular intervals and to have them overhauled in the maintenance shop. The same applies to lights found unserviceable in the field.

No specific tools are required to remove or re-install the fittings, except for the lifting tool, see § [How to lift the light fixture out of the base or adapter ring](#) .

5.2.2 Preventive maintenance

The assembly's service life depends to a large extent on its waterproofness. All metal mating surfaces and seals must be clean, smooth, dry and free of all foreign particles if the light fixture is to operate for extended periods without requiring maintenance.

Greasing of O-ring seals may be required as indicated in this manual.

Preventive maintenance of the light fixtures should be performed as listed in the table on the next page.

Maintenance frequency depends on the conditions under which the runway is used (i.e. climate, traffic, etc.). The recommended practices for maintenance are described in the FAA advisory circular no. AC 150/5340-26 and in the ICAO Aerodrome Design Manual, Part 9 Airport Maintenance Practices.



Note

For components mentioned in this chapter, refer to the exploded view § [Exploded view](#) .

Make sure not to let the fitting rest on the inner cover, in order not to harm the pressure gland cable entry in the inner cover. Therefore, always turn the fitting upside down next to the base when lifting it out of the base.

5.2.3 Preventive maintenance tasks

Although the inset flashing lights are of a superior quality, it is recommended to perform maintenance tasks in a preventive way. In the table below you will find a checklist of preventive maintenance tasks according to a time schedule as recommended by the FAA. In practice it will prove that the frequency can be lowered drastically depending on the local circumstances.

Interval	Check	Action
Daily	for lamp failure	Replace lamp.
	for low light output	<ol style="list-style-type: none"> 1. Clean outer surface of prism if dirty. 2. Check for presence of moisture in fixture: <ol style="list-style-type: none"> a. Open up light assembly. b. Clean, dry and inspect. c. Replace O-ring and other parts found defective. 3. Check for lamp aging or displacement
Weekly	for obstruction in light output channel	Clean channel and prism surface
Monthly	for presence of moisture or water (visual inspection on condensation inside of prisms)	<ol style="list-style-type: none"> 1. Open up light assembly. 2. Clean, dry and inspect. 3. Replace O-ring and other parts found defective.
Bimonthly	torque on hold-down bolts	For the tool to use, the requirement for use of Loctite and the torque to apply, see § How to mount the light on the base or adapter ring and connect it .
Semi-annually *	for presence of water in base	<ol style="list-style-type: none"> 1. Pump water from base. 2. Remove, dismantle and inspect light for water damage. 3. Cure the cause of water ingress.
After 900 hours of operation at 1 flash per sec.	Replace the lamp	It is recommended to replace the lamps systematically when, at full intensity, 80 % of the useful life has been reached.
After snow removal	for damaged light fixtures	<ol style="list-style-type: none"> 1. Replace badly damaged fixtures. 2. Use a power broom for snow removal in the vicinity of the light fixture, if practical. 3. Follow recommended snow removal techniques described in FAA AC 150/5200-30 to avoid or at least to reduce damage to light fixtures.

Notes

* More frequently during rainy seasons.

5.3 How to lift the light fixture out of the base or adapter ring

5.3.1 Lifting tool

Beside the simple jig delivered with the standard tool case, ADB SAFEGATE has developed a more sturdy and efficient lifting tool, see § [Procedure](#) .

5.3.2 Procedure

To lift the optical unit out of the base receptacle or adapter ring, proceed as follows:

1. Remove the fixing screws and washers (A1-A2) or self locking nuts and discard them.
2. Fit the appropriate lifting tool into both holes located (180° apart) in the cover (B1), lift the optical unit out of the base or adapter ring and place it next to it.

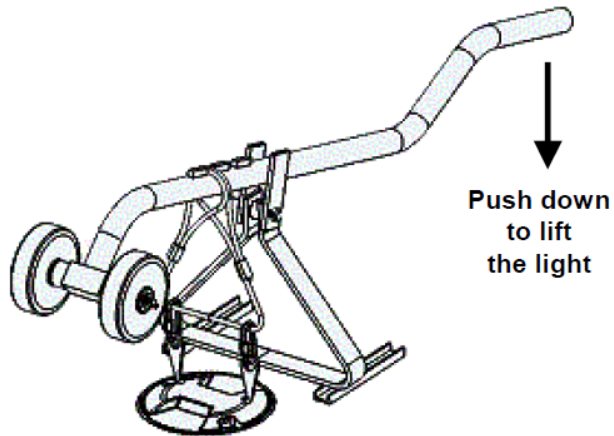

3. Disconnect the light fixture wires from the power cable coming from the FCU.
4. Remove the O-ring gasket and discard it.
5. Mount a serviced or new fitting, see § [How to mount the light on the base or adapter ring and connect it](#) .
6. Take the optical unit back to the maintenance base where it can be serviced entirely.



CAUTION

Never hold the light fixture by the wires as this may damage the insulation, break the waterproof seal and cause insulation faults and water leakage.

6.0 Servicing in the Maintenance base

6.1 Introduction

This chapter describes how to perform the various servicing tasks in the maintenance base.

All the screws used in this product are listed at the end of this manual.

Note For the tool to use and the torque to apply, see § [Screws Overview](#) .

6.2 How to open the light assembly

6.2.1 Procedure

For the tool to use and the torque to apply, see § [Screws Overview](#) .

To open the light assembly, proceed as follows:

1. Turn the light unit upside down. In order for the light to rest on a stable surface it is advised to lay it upside down on the top of a shallow base.

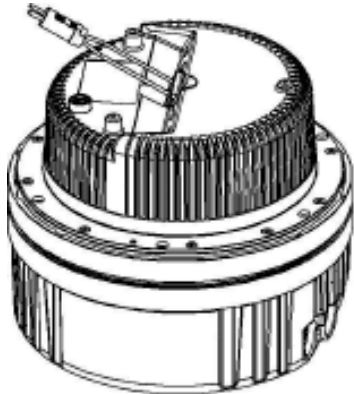

2. Remove the pressure release screw (D5).

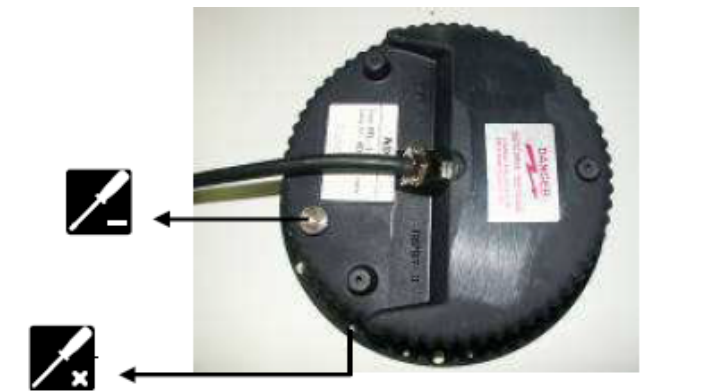

3. Remove the 10 screws (D7). The use of an attack driver may be required to unlock the screws (see photo above).

- Always use a new bit for each light requiring the use of an attack driver.
- Take care that the bit is well positioned on the screw head and that the driver is aligned with the axis of the screw.

4. Introduce the special opening tool (NC 4071.53.220) in the dedicated slot between cover and inner cover and rotate it to separate the inner cover from the cover.

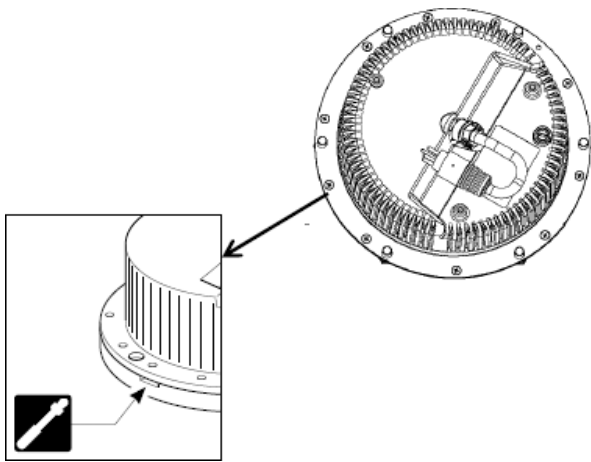

6.3 How to replace the lamp

6.3.1 Procedure

For the tool to use and the torque to apply, see § [Screws Overview](#) .

To replace a lamp, proceed as follows:

1. Disconnect the fast-on connectors and the trigger wire of the lamp (C1) from the Lamp PCB (C3).
2. Remove the lamp from the Lamp PCB, holding the reflector.
3. Install a new lamp:
 - a. The lamp is supplied ready for installation.
 - b. Gently position the lamp with its grommets on the lamp holder clamps and push down.



CAUTION

1. The lamp is very brittle so handle with care.
2. Never touch the quartz bulb of the lamp with your bare fingers. It would reduce the lifetime of the lamp considerably. Should it happen, clean the bulb with methylated spirit.
3. Make sure that the lamp is positioned with the trigger wire horizontal as per following drawing:

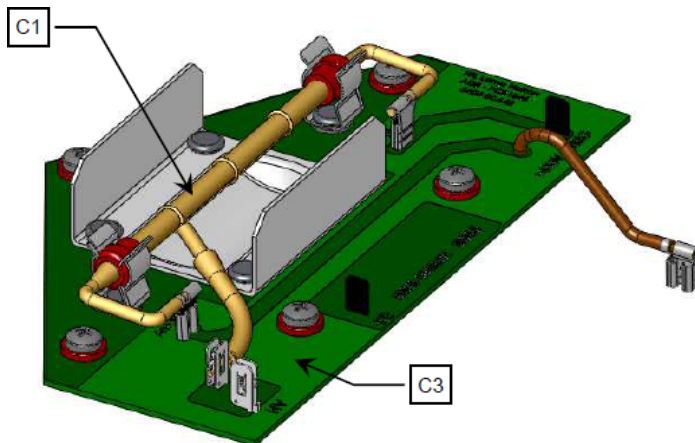



Note

Make sure there is good contact between fast-on connectors and terminals.

4. Reconnect the fast-on connectors and trigger wire in reverse order.



Note

First version of the light featured a fast-on connector for the trigger too. For the right part number of the lamp, see § [Spare Parts](#) .

6.4 How to replace the prism

6.4.1 Procedure

For the tool to use and the torque to apply, see § [Screws Overview](#) .

To replace a prism, proceed as follows:

1. The use of an attack driver may be required to unlock the screws fastening the prism.
 - Always use a new bit for each light requiring the use of an attack driver.
 - Take care that the bit is well positioned on the screw head and that the driver is aligned with the axis of the screw.
2. Remove the prism keeper plate (B4) secured in the cover.
3. Remove the flat gasket (B3c).
4. Push the prism (B3a) with the sleeve gasket (B3b) towards the inside of the cover.
5. Clean and degrease the prism chamber with any effective solvent.



CAUTION

Never use any abrasive substance.

Remnants of Loctite are present in the fixation holes of the screws B5. Clean them using a cleaning tap for blind holes (preferably use a tap with a right spiral groove) and blow with dry, oil-free compressed air.

6. Apply a thin layer of lubricant MOLYKOTE HP870 INERTA (PN 7850.05.061) in the prism chamber using a small brush.
7. Position the cover upside down on the working table.
8. Take a new prism (B3b) and slide it into a new sleeve gasket (B3a).
9. Push the prism/gasket assembly into the prism chamber. Clean the inner surface of the prism with methylalcohol.
10. Position a new flat gasket (B3c) and prism keeper plate (B4) over the prism (B3b).
11. Introduce new screws (B5) and torque them down crosswise to secure the prism and to obtain a uniform, stressless positioning of the prism in its chamber.



Note

For the tool to use and the torque to apply, see § [Screws Overview](#) .

6.5 How to replace the trigger PCB

6.5.1 Former version

On the first version of the FFL, the trigger PCB and the lamp PCB were not detachable from each other. In this case both PCBs need to be replaced together in case of failure of one of them.

6.5.2 Procedure

To replace the Trigger PCB, proceed as follows:

For the tool to use and the torque to apply, see § [Screws Overview](#) .

1. Disconnect the wires from the terminal block, by inserting a small screwdriver in the upper contact hole and pushing on the spring contact of each particular terminal.
2. Disconnect the wires connecting the trigger PCB (C4) to the lamp PCB (C3).
3. Remove the Trigger PCB by loosening the screws (C5).

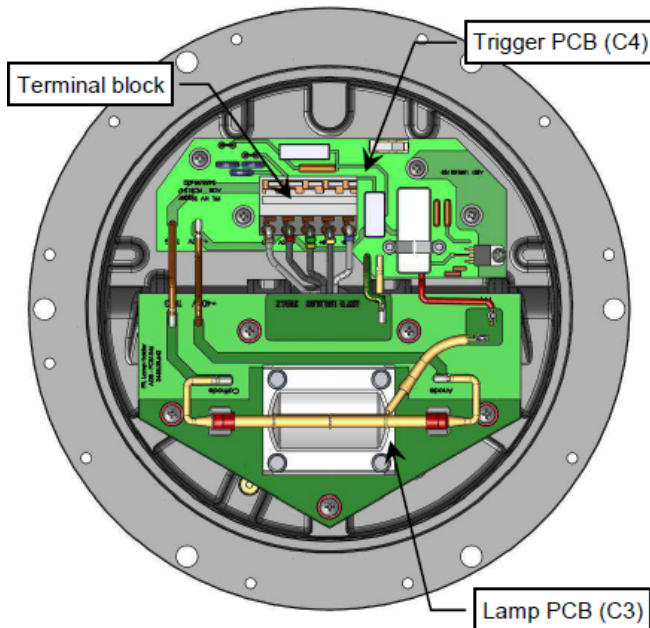

4. Position the new PCB.
5. Torque down the fixing screws (C5).



Note

For the tool to use and the torque to apply, see § [Screws Overview](#) .

6. Connect the wires to the terminal block and to the lamp PCB
For the connection of the terminal block, see § [How to replace the cable set assembly](#) .

6.6 How to replace the lamp PCB

6.6.1 Former version

On the first version of the FFL, the trigger PCB and the lamp PCB were non detachable from each other. In this case both PCBs need to be replaced together in case of failure of one of them.

6.6.2 Procedure

To replace the lamp PCB, proceed as follows:

For the tool to use and the torque to apply, see § [Screws Overview](#) .

1. Remove the lamp, see § [How to replace the lamp](#) .
2. Disconnect the wires connecting the trigger PCB (C4) to the lamp PCB (C3).
3. Remove the lamp PCB by loosening the screws (C2).

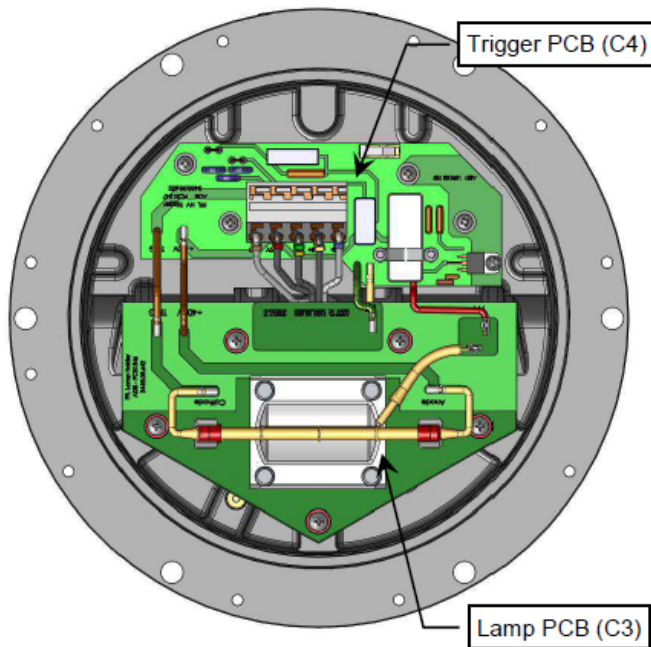

4. Position the new PCB with its new dampers (supplied with the PCB).
5. Torque down the fixing screws (C2).



Note

For the tool to use and the torque to apply, see § [Screws Overview](#) .

6. Connect the wires to the lamp PCB
7. Reinstall the lamp, see § [How to replace the lamp](#) .

6.7 How to replace the cable set assembly

6.7.1 Cable sets

Only use ADB SAFEGATE supplied cable sets. Usage of substitutes voids the warranty.

6.7.2 Procedure

For the tool to use and the torque to apply, see § [Screws Overview](#) .

To replace the cable set assembly, proceed as follows:

1. Remove the trigger PCB (C4) and the lamp PCB (C3), see § [How to replace the trigger PCB](#) and § [How to replace the lamp PCB](#) .
2. Untighten the PG cable gland (D3).
3. Pull the cable assembly (D4) out of the inner cover (D1).
4. Bring the new ADB SAFEGATE supplied cable assembly through the PG cable gland. Provide sufficient slack to connect the cable wires to the terminal block.

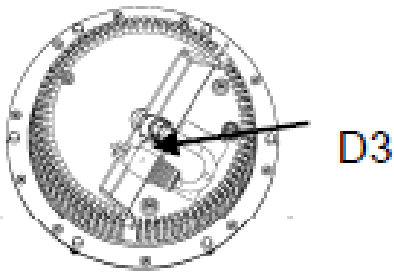

CAUTION

Always replace the PG grommet each time the PG is opened.

5. Tighten the PG sufficiently to make a perfect water barrier.
6. Remove the insulation of the wires over about 5 mm.
7. Wires are identified by colored labels. Connect the wires according to the following table:

<u>Wire label</u>	<u>to terminal</u>
Brown "1"	TRIG
Red "2"	+400V
Green/yellow "54"	PE
Orange "3"	CAB+
Blue "6"	CAB-

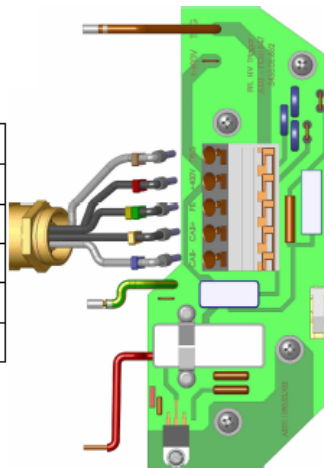

8. Re-install the trigger PCB and the lamp PCB, see § [How to replace the trigger PCB](#) and § [How to replace the lamp PCB](#) .

6.8 How to close and test the light fixture

6.8.1 Procedure



Note

Always replace cover/inner cover gaskets and fixing screws by new ones!

To close an optical unit, proceed as follows:

Step-Action

1. Turn the cover (B1) upside down. In order for the cover to rest on a stable surface it is advised to lay it upside down on the top of a shallow base.

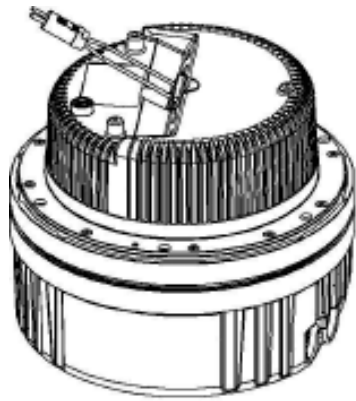

2. Make sure that the contact surfaces with the O-ring are clean.
Remnants of Loctite may be present in the fixation holes of the screws D7. Clean them using a cleaning tap for blind holes (preferably use a tap with a right spiral groove) and blow with dry, oil-free compressed air.
3. Put a new O-ring gasket (B2) greased with high quality neutral silicone grease (ADB PN 7850.42.210) over the cover in the appropriate groove.
4. Remove the pressure release screw (D5).

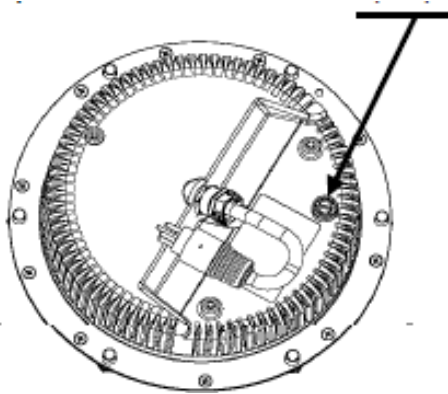

5. Gently put the inner cover (D) on the cover (B), taking into account the keying pin between both parts.
6. Press the inner cover on the cover and secure with the screws (D7).



Note

For the tool to use and the torque to apply, see § [Screws Overview](#) .

7. Dielectric test:
Check electrical insulation from each 5-pole plug wire to light body by means of a 2500V AC insulation tester. Therefore, interconnect the poles 1, 2, 4 and 5 and connect and measure against the light body (make sure not to include the earthing pole (central pin of the connector)).
Connect the fitting to a FCU control unit and check the correct functioning of the lamp.
8. Check waterproofness of the fitting by applying **with dry air** a pressure of 0.4 bar (40 kPa) above the atmospheric pressure via the pressure release hole. Whilst pressure is applied, immerse the light fixture for three minute in water and look carefully for NO stream of bubbles emanating from the light fixture. If no leakage occurs, dry the fixture and remove the air hose.
Else, locate the leak source. Dry the fixture, remove the air hose. Replace the leaking gasket or part (check the contact surfaces for any scratches, corrosion or other damage) and repeat the test.
For this purpose a water-tightness test adapter can be ordered from ADB SAFEGATE, see § [Accessories](#) .
9. Replace the O-ring seal of the pressure release screw (D6) and secure the pressure release screw.



Note

For the tool to use and the torque to apply, see § [Screws Overview](#) .

7.0 Troubleshooting

In the table below a number of potential problems are listed in the first column. In the second column, you will find the possible causes of the problem and in the third column the solution.

Problem	Possible cause	Solution
Light does not energize.	Lamp(s) defective	Replace lamp.
	Bad lamp or cable connections, broken contacts	Check the plug receptacle assembly in the light base. Check connections of the lamp on the PCB or the cable wires in the terminal block and tighten. Also check the connection on the control equipment side.
	Faulty trigger transformer	Replace the trigger PCB.
	Open or faulty micro switch	Check if the spacer pushing the micro- switch contacts is well in place or if the micro-switch is not broken. Replace the PCB, if necessary.
	Moisture inside assembly causing current leakage	<ol style="list-style-type: none"> 1. Open light assembly. 2. Clean, dry, inspect or replace damaged components.
	Defective control electronics	Refer to the FCU manual for trouble shooting of the control electronics.
Light does not energise at normal level.	Light misaligned. Dirty prism.	Clean prism and check orientation of light.
Light beam out of alignment	Broken or damaged prism/cover	<ol style="list-style-type: none"> 1. Replace prism or entire outer cover assembly. 2. Check lamp positioning.
Short lamp life	Moisture in assembly	<ol style="list-style-type: none"> 1. Open light assembly. 2. Clean, dry, inspect or replace damaged components.

8.0 Ordering Codes and Exploded View

8.1 Introduction

In this chapter you will find an overview of the main and sub-assemblies and the exploded views of the 12-inch F-Range inset lights.

8.2 Complete Products and Spare Parts

8.2.1 Spare Parts

It is recommended to create a sufficiently large stock of spare parts to maintain the fittings. It will mainly consist of consumables like lamps, O-ring gaskets, film disc cutouts, etc. Other components that may need replacement, such as prisms, prism gaskets, terminal blocks and hardware even as sub-assemblies, should be stocked in smaller quantities. The stock should also contain some complete fittings of each type.

8.2.2 FFL Fixtures and Shallow Bases

In the table below you will find all FFL fixtures and shallow bases:

FFL9C0000001	Fitting Inset flashing light type FFL including trigger electronics and low voltage flashing lamp, without base nor fixing hardware
MSBB4901003	12" shallow base With UNC screws and side cable entry
MSBB4A01003	12" shallow base With UNC screws and central bottom hole - without 5-pole receptacle assembly
MSBB5901003	12" shallow base With metric screws and side cable entry - without 5-pole receptacle assembly
MSBB5A01003	12" shallow base With metric screws and central bottom hole - without 5-pole receptacle assembly
SP.4072.03.960	5-pole receptacle assy (see page 12)



Note

Complete fixtures are supplied without fixing hardware. Fixing hardware is supplied with the mounting system (bases or mounting rings) or can be ordered separately (see [Table 2](#)).

8.2.3 Fixing hardware kits

In the table below you will find the fixing kits of 8" and 12" F-Range inset lights: The choice for hardware kit depends on several criteria : the used thread in the base (metric or UNC), the use of screws or studs and the base itself (refer to interoperability matrix)

Table 1: Fixing hardware kits of F-Range inset lights

METRIC FIXING HARDWARE KITS								
Fixing hardware kit		Components						
Description	Part Number	7100.08.759 St. Steel Screw M10 X25	7150.53.320 St. Steel Nut M10	7150.53.330 St. St. Steel Self-Locking Nut M10 H100	7150.53.335 St. St. Self-Locking Nut M10 H80	7284.10.470 St. Steel Lock Washer M10	7284.70.345 Nylon Encap. Washer M10	4071.50.240 Metric Anti-Rotation Pin
For mounting 8" inset lights on to 8" shallow bases or adapter rings								
Metric screw kit 8" (with anti-rotation pins)	1411.20.400	2				2		2
Metric nut kit 8"	1411.20.420		2			2		
Self-locking metric nut kit 8 (H100)"	1411.20.430			2				
Self - locking metric nut kit 8" (H80)	1411.20.435				2			
Metric screw kit 8" (Germany)	1411.20.441	2					2	
Metric screw kit 8" (w/o anti-rotation pins)	1411.20.522	2				2		
For mounting 12" inset lights or adapter rings on 12" shallow or deep bases								
Metric screw kit (France) 12"	1411.20.482	6				6		
Metric screw kit 12" (Germany)	1411.20.492	6					6	
Self-locking nut kit 12" (H100)	1411.20.500			6				
Self-locking metric nut kit 12" (H80)	1411.20.505				6			

Notes

¹ Note (1): HPI bases only accept Metric hardware

UNC FIXING HARDWARE KITS							
Fixing hardware kit			Components				
Description	Part Number						
		7200.13.806 St. St. Screw 3/8" - 16 UNC	7284.10.470 St. Steel Lock Washer M10	4027.50.120 UNC Anti-Rotation Pin			
For mounting 8" inset lights on 8" shallow bases or adapter rings							
UNC screw kit 8"	1411.20.411	2	2	2			
For mounting 12" inset lights or adapter rings on 12" shallow or deep bases							
UNC screw kit 12"	1411.20.452	6	6				

8.2.4 FFL Parts

Ref.	Part number	Description	Qty used in fitting	Order quantity (per xx)
B	1440.02.300	FFL Cover assy, including:	1	1
B1	SP4072.02.010	FFL machine cover	1	1
B2	SP011445	F - range 12" O-ring gasket	1	10
B3,B4,B5	4072.06.720	FFL prism kit consisting of:	1	1
		FFL sleeve gasket for prism	1	1
		FFL prism	1	1
		FFL flat seal for prism	1	1
		FFL prism keeper plate	1	1
		SCREW M5x13 DIN 7985-T-A2-LOCK 2045	10	100
C1	SP010710	FFL flashing lamp 60J - 400V (see note 1)	1	1
C2	SP4071.53.703	SCREW M5x13 DIN 7985-T-A2-LOCK 2045	5	100
C3	SP010867	Trigger PCB (see note 2)	1	1
C4	SP010845	Lamp PCB (see note 2) - does not include the lamp	1	1
C5	SP7110.08.360	SCREW M4x10 DIN 7500CE-T-A2	5	100
D	1440.02.310	FFL inner inner cover assembly including (D includes D1,D2..D7):	1	1
D1	SP4072.02.040	Machined FFL inner cover	1	1
D2	SP013114	O-ring seal between top cover and shallow base, for F-Range 12-in	1	10
	SP013115	PG16 cable entry IP54 cable diameter 10.5 to 16 mm	1	100
D3	SP6126.01.330	PG16 cable entry IP54 cable diameter 10-14 mm	1	10
D4	SP4072.03.980	5-pole plug assembly	1	5
D5,D6	SP010869	Pressure release screw and O-ring for the pressure release screw	1	10
D7	SP7100.10.190	SCREW M5x10 DIN 965-T-A2-LOCK 2045	10	100

In the table below you will find the commercially available spare parts and main assemblies of the FFL light fitting (the part numbers refer to the exploded drawing below):



Note

1. Former version of the lamp, with fast-on connector on the trigger wire: SP. 010709
2. Order one Trigger PCB and one Lamp PCB to replace former FFL PCB ref. 4072.16.690.

8.3 Screws Overview

The table below gives for each screw used in the FFL 12-inch, the reference to the type of screw, the tool to use, and the torque:

Screw	Tool	Torque
A1 (not supplied with the light) Screw FT.HEX M10 x 25, SST, Hex Head or Screw FT.HEX 3/8"-16UNC X7/8"	Socket hex 17 mm or Socket hex 9/16-in	21 Nm / 190 Lb.in
B5 - 4071.53.703 - SCREW M5x13 DIN 7985-T-A2-LOCK 2045	Torx 25	3.5 Nm / 31 Lb.in
C2 - 4071.53.703 - SCREW M5x13 DIN 7985-T-A2-LOCK 2045	Torx 25	3.5 Nm / 31 Lb.in
C5 - 7100.08.360 - SCREW M4x10 DIN 7500CE-T-A2Screw THRD M4X10 Stainless Steel	Torx 20	3.3 Nm / 30 Lb.in
D7 - 7100.10.190- SCREW M5x10 DIN 965-T-A2-LOCK 2045	Torx 25	2.5 Nm / 23 Lb.in
D3 - PG16 cable entry	Flat spanner	
D5 - 4070.77.150 - pressure release screw	1.6x8 Flat	2.5 Nm / 23 Lb.in
Self-locking nut (M10)	Socket hex 17 mm	21 Nm / 190 Lb.in
Screws delivered for installation of adapter ring on deep base	Socket hex 17 mm or Socket hex 9/16-in	21 Nm / 190 Lb.in

8.4 Exploded view

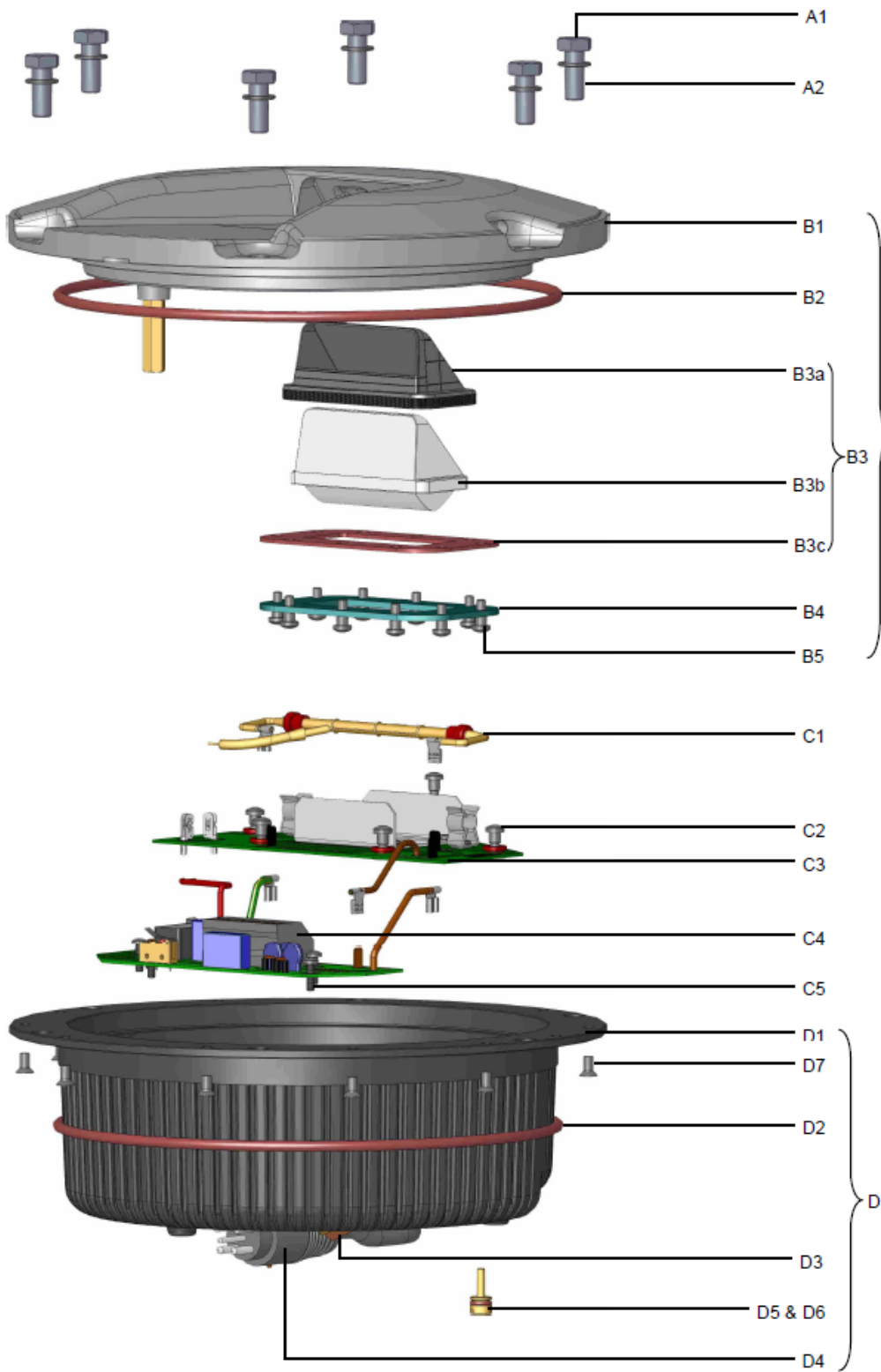

8.5 Accessories

In the lists below you will find useful accessories for the installation, maintenance and repair of the 12-inch F-Range inset lights.

8.5.1 Tool case

ADB SAFEGATE has designed a tool case, ADB part number **1411.19.421**, including the basic tools necessary for the maintenance of inset lights. It can also be used for the installation of the light fixture. Please note, this is a general tool case, some tools are of no use for 12-inch F-Range inset lights. The table below lists the tools included in the case:

Description	Part number	Description	Part number
Tool case	6169.01.007	Screwdriver, flat blade AG. 8×150	8961.05.250
Torque wrench	8961.06.255	Screwdriver, Pozidriv AD.2×125	8961.05.220
Socket hex 3/8", screw 3/8", J 9/16LA	8961.06.008	Loctite 2701	7870.05.130
Socket hex 3/8", screw M10, J 17LA	8961.06.000	Loctite 222	7870.05.140
Socket, 1/4", 1.6x8 Flat, RS.8E	8961.05.050	Lubricant Molykote HP870 Inerta (100 gr), (to replace prism)	7850.05.061
Socket, 1/4", Pozidriv2, RD.2	8961.05.060	Natural hydraulic vacuum silicone grease (50 gr)	7850.42.220
Extension, 1/4", R.210	8961.06.220	Attack driver	8961.04.100
Adaptation, 1/4"-3/8", R.232	8961.06.010	Dead blow hammer	8961.04.110
Hinged handle - short	8981.06.110	Bit holder	8961.04.120
Plier	8961.10.110	Bits END202, Pozidriv2	8961.04.130
Opening tool	4071.53.220	Lifting tool assembly for inset lights	1411.19.550
Screwdriver ANX25×100 TX20	8961.05.300	Bit Torx 1/4" - TX20 EX.620 L=70 mm	8961.06.020
Screwdriver ANX25×100 TX25	8961.05.290	Bit Torx 1/4" - TX20 EX.625 L=70 mm	8961.06.025

8.5.2 Additional accessories

The following accessories can be purchased separately:

Description	Part number
Watertightness test adapter for inset lights	4060.84.570
Set of spare anchor hooks for lifting tool 1411.19.550	1411.19.560
Lifting tool on wheels (see § How to lift the light fixture out of the base or adapter ring)	1420.55.600

Appendix A: SUPPORT

Our experienced engineers are available for support and service at all times, 24 hour/7 days a week. They are part of a dynamic organization making sure the entire ADB SAFEGATE is committed to minimal disturbance for airport operations.

ADB SAFEGATE Support

Technical Support – Global

Customers in Europe, the Middle East, Africa or Asia Pacific are more than welcome to our portal for technical support. Trained in all areas of system issues, troubleshooting, quality control and technical assistance, our highly experienced Technical support specialists are available 24 hours a day, seven days a week to provide assistance over the phone. In the Americas, we also offer live technical support.

Live Technical Support – Americas

If at any time you have a question or concern about your product, contact ADB SAFEGATE's US-based technical support specialists, available 24 hours a day, seven days a week, to assist you via phone.

ADB SAFEGATE Americas Technical Service & Support (US & Canada) :+1-800-545-4157

ADB SAFEGATE Americas Technical Service & Support (Canada): +1-905-631-1597

ADB SAFEGATE Americas Technical Service & Support (International): +1-614-861-1304

We can also be reached via email during regular business hours:

Airfield and Gate: techservice.us@adbsafegate.com

Gate: gateservice.us@adbsafegate.com

We look forward to working with you!

Before You Call

When you have an airfield lighting or system control system problem, prior to calling, please ensure the following:

- Review the product's manual and troubleshooting guide.
- Be located with the product ready to troubleshoot.
- Have all necessary information available: airport code/company name, customer id number, contact phone number/email address, product/part number.
- Have a *True RMS* meter available and any other necessary tools.

When calling about an issue with Safedock A-VDGS, we can serve you better if you collect the following information before you call:

- Relevant information regarding the issue you are calling about, such as gate number, flight number, aircraft type and time of the event.
- What, if any, actions have been taken to resolve the issue prior to the call.
- If available, provide a CCTV recording of the incident to aid in aligning the information from the Safedock log file.

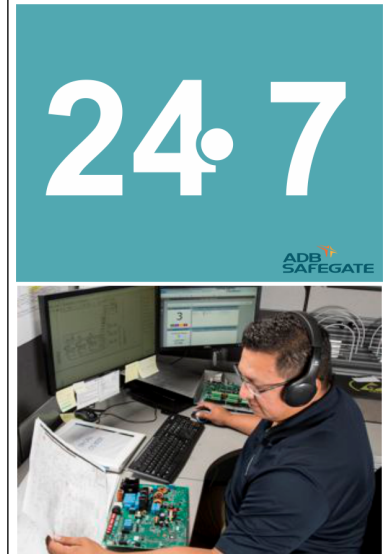

Note

For more information, see www.adbsafegate.com, contact ADB SAFEGATE Support via email at support@adbsafegate.com or

Europe: +32 2 722 17 11

Americas: +1 614 861 1304. Press 3 for technical service or press 4 for sales support.

China: +86 (10) 8476 0106

Middle East and Africa: +971 4 452 7575

A.1 ADB SAFEGATE Website

The ADB SAFEGATE website, www.adbsafegate.com, offers information regarding our airport solutions, products, company, news, links, downloads, references, contacts and more.

A.2 Recycling

A.2.1 Local Authority Recycling

The disposal of ADB SAFEGATE products is to be made at an applicable collection point for the recycling of electrical and electronic equipment. The correct disposal of equipment prevents any potential negative consequences for the environment and human health, which could otherwise be caused by inappropriate waste handling. The recycling of materials helps to conserve natural resources. For more detailed information about recycling of products, contact your local authority city office.

A.2.2 ADB SAFEGATE Recycling

ADB SAFEGATE is fully committed to environmentally-conscious manufacturing with strict monitoring of our own processes as well as supplier components and sub-contractor operations. ADB SAFEGATE offers a recycling program for our products to all customers worldwide, whether or not the products were sold within the EU.

ADB SAFEGATE products and/or specific electrical and electronic component parts which are fully removed/separated from any customer equipment and returned will be accepted for our recycling program.

All items returned must be clearly labeled as follows:

- For *RoHS/WEEE* Recycling
- Sender contact information (Name, Business Address, Phone number).
- Main Unit Serial Number.

ADB SAFEGATE will continue to monitor and update according for any future requirements for *EU directives* as and when *EU member states* implement new *regulations* and or *amendments*. It is our aim to maintain our *compliance plan* and assist our customers.

Company Addresses

ADB SAFEGATE, Belgium	ADB SAFEGATE BV Leuvensesteenweg 585 B-1930 Zaventem Belgium
Contact: Tel.: +32 2 722 17 11 Fax: +32 2 722 17 64	Email: marketing@adbsafegate.com Internet: www.adbsafegate.com
ADB SAFEGATE, Americas	ADB SAFEGATE Americas, LLC 700 Science Blvd Gahanna, OH 43230 USA
Contact: Tel.: +1 (614) 861 1304 Fax: +1 (614) 864 2069	Email: sales.us@adbsafegate.com Internet: www.adbsafegate.com
ADB SAFEGATE, Sweden	ADB SAFEGATE Sweden AB Djurhagegatan 19 SE-213 76 Malmö Sweden
Contact: Tel.: +46 (0)40 699 17 00 Fax: +46 (0)40 699 17 30	Email: marketing@adbsafegate.com Internet: www.adbsafegate.com
ADB SAFEGATE, China	ADB SAFEGATE Airfield Technologies Ltd. China Unit 603, D Block, CAMIC International Convention Center, No 3, Hua Jia Di East road, ChaoYang district, Beijing 100102 P.R. China
Contact: Tel.: +86 (10) 8476 0106 Fax: +86 (10) 8476 0090	Email: china@safegate.com Internet: www.adbsafegate.com
ADB SAFEGATE, Germany	ADB SAFEGATE Germany GmbH Konrad-Zuse-Ring 6, D-68163 Mannheim Germany
Contact: Tel.: +49 (621) 87 55 76-0 Fax: +49 (621) 87 55 76-55	Email: marketing@adbsafegate.com Internet: www.adbsafegate.com



Powering Your Airport Performance from Approach to Departure

adbsafegate.com

Copyright © ADB SAFEGATE, all rights reserved

