



L-852T(L) / ITEL-L

LED In-pavement Taxiway Edge Light, Medium-Intensity

User Manual

96A0338, Rev. V, 2024/05/10

**ADB
SAFEGATE**

A.0 Disclaimer / Standard Warranty

CE certification

The equipment listed as CE certified means that the product complies with the essential requirements concerning safety and hygiene. The European directives that have been taken into consideration in the design are available on written request to ADB SAFEGATE.

ETL certification

The equipment listed as ETL certified means that the product complies with the essential requirements concerning safety and C22.2 No.180:13 (R2018) regulations. The CSA directives that have been taken into consideration in the design are available on written request to ADB SAFEGATE.

All Products Guarantee

ADB SAFEGATE will correct by repair or replacement per the applicable guarantee below, at its option, equipment or parts which fail because of mechanical, electrical or physical defects, provided that the goods have been properly handled and stored prior to installation, properly installed and properly operated after installation, and provided further that Buyer gives ADB SAFEGATE written notice of such defects after delivery of the goods to Buyer. Refer to the Safety section for more information on Material Handling Precautions and Storage precautions that must be followed.

ADB SAFEGATE reserves the right to examine goods upon which a claim is made. Said goods must be presented in the same condition as when the defect therein was discovered. ADB SAFEGATE further reserves the right to require the return of such goods to establish any claim.

ADB SAFEGATE's obligation under this guarantee is limited to making repair or replacement within a reasonable time after receipt of such written notice and does not include any other costs such as the cost of removal of defective part, installation of repaired product, labor or consequential damages of any kind, the exclusive remedy being to require such new parts to be furnished.

ADB SAFEGATE's liability under no circumstances will exceed the contract price of goods claimed to be defective. Any returns under this guarantee are to be on a transportation charges prepaid basis. For products not manufactured by, but sold by ADB SAFEGATE, warranty is limited to that extended by the original manufacturer. This is ADB SAFEGATE's sole guarantee and warranty with respect to the goods; there are no express warranties or warranties of fitness for any particular purpose or any implied warranties of fitness for any particular purpose or any implied warranties other than those made expressly herein. All such warranties being expressly disclaimed.

Standard Products Guarantee

Products manufactured by ADB SAFEGATE are guaranteed against mechanical, electrical, and physical defects (excluding lamps) which may occur during proper and normal use for a period of two years from the date of ex-works delivery, and are guaranteed to be merchantable and fit for the ordinary purposes for which such products are made.



Note

See your applicable sales agreement for a complete warranty description.

Replaced or repaired equipment under warranty falls into the warranty of the original delivery. No new warranty period is started for these replaced or repaired products.

FAA Certified products manufactured by ADB SAFEGATE

ADB SAFEGATE L858 Airfield Guidance Signs are warranted against mechanical and physical defects in design or manufacture for a period of 2 years from date of installation, per FAA AC 150/5345-44 (applicable edition).

ADB SAFEGATE LED products (with the exception of obstruction lighting) are warranted against electrical defects in design or manufacture of the LED or LED specific circuitry for a period of 4 years from date of installation, per FAA EB67 (applicable edition). These FAA certified constant current (series) powered LED products must be installed, interfaced and powered with and through products certified under the FAA Airfield Lighting Equipment Program (ALECP) to be included in this 4 (four) year warranty. This includes, but is not limited to, interface with products such as Base Cans, Isolation Transformers, Connectors, Wiring, and Constant Current Regulators.



Note

See your sales order contract for a complete warranty description.

Replaced or repaired equipment under warranty falls into the warranty of the original delivery. No new warranty period is started for these replaced or repaired products.

Liability



WARNING

Use of the equipment in ways other than described in the catalog leaflet and the manual may result in personal injury, death, or property and equipment damage. Use this equipment only as described in the manual.

ADB SAFEGATE cannot be held responsible for injuries or damages resulting from non-standard, unintended uses of its equipment. The equipment is designed and intended only for the purpose described in the manual. Uses not described in the manual are considered unintended uses and may result in serious personal injury, death or property damage.

Unintended uses, includes the following actions:

- Making changes to equipment that have not been recommended or described in this manual or using parts that are not genuine ADB SAFEGATE replacement parts or accessories.
- Failing to make sure that auxiliary equipment complies with approval agency requirements, local codes, and all applicable safety standards if not in contradiction with the general rules.
- Using materials or auxiliary equipment that are inappropriate or incompatible with your ADB SAFEGATE equipment.
- Allowing unskilled personnel to perform any task on or with the equipment.

Copyright Statement

This manual or parts thereof may not be reproduced, stored in a retrieval system, or transmitted, in any form or by any means, electronic, mechanical, photocopying, recording, nor otherwise, without the author's prior written consent.

This manual could contain technical inaccuracies or typographical errors. The author reserves the right to revise this manual from time to time in the contents thereof without obligation of the author to notify any person of such revision or change. Details and values given in this manual are average values and have been compiled with care. They are not binding, however, and the author disclaims any liability for damages or detriments suffered as a result of reliance on the information given herein or the use of products, processes or equipment to which this manual refers. No warranty is made that the use of the information or of the products, processes or equipment to which this manual refers will not infringe any third party's patents or rights. The information given does not release the buyer from making their own experiments and tests.

TABLE OF CONTENTS

1.0 Safety	1
1.1 Safety Messages	1
1.1.1 Introduction to Safety	2
1.1.2 Intended Use	3
1.1.3 Material Handling Precautions: Storage	3
1.1.4 Material Handling Precautions: Fasteners	3
1.1.5 Maintenance Safety	4
1.1.6 Material Handling Precautions, ESD	4
1.1.7 Arc Flash and Electric Shock Hazard	5
2.0 L-852T(L) / ITEL-L	7
2.1 About this manual	7
2.2 ITEL-L Product Introduction	7
2.2.1 LED In-pavement Taxiway Edge Light	7
3.0 Installation	9
3.1 Input Requirement Summary	9
3.2 Typical L-868 Assembly	10
3.3 Safety Considerations	11
3.4 Photobiological safety	11
3.5 Verify Input Requirements and Equipment Needed	11
3.6 Unpacking the Unit	12
3.7 Inspect on delivery	12
3.8 Store	13
3.9 Installation on L-868 Base	13
3.10 Installing Adapter Ring	14
3.11 Adapter Ring Mounting and Connection	15
3.12 Torquing and Installation Guidance for In-pavement Fixtures	15
3.13 Shallow base can installation	16
3.13.1 Installation on a Shallow Base	16
4.0 Maintenance	19
4.1 Maintenance Schedule	19
4.2 Removing L-867 and L-868 Base Water	19
4.3 Bolt Torque Preventive Maintenance Schedule	20
5.0 Troubleshooting	23
5.1 Repair	24
5.1.1 Lifting Optical Unit From Base	25
5.1.2 Opening Assembly	26
5.1.3 Cleaning the Lens	28
5.1.4 Testing an LED assembly	28
5.1.5 Replacing LED Assembly	29
5.1.6 Replacing Lens and Lens Gasket	33
5.1.7 Closing and Testing Light Assembly	35
5.1.8 Testing for Leaks	36
6.0 ITEL Parts	39
6.1 ITEL Spare Parts	39
6.2 Illustrated Parts List	40
A.0 SUPPORT	43
A.1 ADB SAFEGATE Website	44
A.2 Recycling	45
A.2.1 Local Authority Recycling	45
A.2.2 ADB SAFEGATE Recycling	45

1.0 Safety

Introduction to Safety

This section contains general safety instructions for installing and using ADB SAFEGATE equipment. Some safety instructions may not apply to the equipment in this manual. Task- and equipment-specific warnings are included in other sections of this manual where appropriate.

1.1 Safety Messages

HAZARD Icons used in the manual

For all HAZARD symbols in use, see the Safety section. All symbols must comply with ISO and ANSI standards.

Carefully read and observe all safety instructions in this manual, which alert you to safety hazards and conditions that may result in personal injury, death or property and equipment damage and are accompanied by the symbol shown below.



WARNING
Failure to observe a warning may result in personal injury, death or equipment damage.



DANGER - Risk of electrical shock or ARC FLASH
Disconnect equipment from line voltage. Failure to observe this warning may result in personal injury, death, or equipment damage. ARC Flash may cause blindness, severe burns or death.



WARNING - Wear personal protective equipment
Failure to observe may result in serious injury.



WARNING - Do not touch
Failure to observe this warning may result in personal injury, death, or equipment damage.



CAUTION
Failure to observe a caution may result in equipment damage.



ELECTROSTATIC SENSITIVE DEVICES
This equipment may contain electrostatic devices.

Qualified Personnel



Important Information

The term **qualified personnel** is defined here as individuals who thoroughly understand the equipment and its safe operation, maintenance and repair. Qualified personnel are physically capable of performing the required tasks, familiar with all relevant safety rules and regulations and have been trained to safely install, operate, maintain and repair the equipment. It is the responsibility of the company operating this equipment to ensure that its personnel meet these requirements.

Always use required personal protective equipment (PPE) and follow safe electrical work practice.

1.1.1 Introduction to Safety

CAUTION

Unsafe Equipment Use

This equipment may contain electrostatic devices, hazardous voltages and sharp edges on components

- Read installation instructions in their entirety before starting installation.
- Become familiar with the general safety instructions in this section of the manual before installing, operating, maintaining or repairing this equipment.
- Read and carefully follow the instructions throughout this manual for performing specific tasks and working with specific equipment.
- Make this manual available to personnel installing, operating, maintaining or repairing this equipment.
- Follow all applicable safety procedures required by your company, industry standards and government or other regulatory agencies.
- Install all electrical connections to local code.
- Use only electrical wire of sufficient gauge and insulation to handle the rated current demand. All wiring must meet local codes.
- Route electrical wiring along a protected path. Make sure they will not be damaged by moving equipment.
- Protect components from damage, wear, and harsh environment conditions.
- Allow ample room for maintenance, panel accessibility, and cover removal.
- Protect equipment with safety devices as specified by applicable safety regulations
- If safety devices must be removed for installation, install them immediately after the work is completed and check them for proper functioning prior to returning power to the circuit.



Failure to follow this instruction can result in serious injury or equipment damage

Additional Reference Materials



Important Information

- IEC - International Standards and Conformity Assessment for all electrical, electronic and related technologies.
- IEC 60364 - Electrical Installations in Buildings.
- CSA - C22.2 No.180:13 (R2018) Series isolating transformers for airport lighting
- FAA Advisory: AC 150/5340-26 (current edition), Maintenance of Airport Visual Aid Facilities.
- Maintenance personnel must refer to the maintenance procedure described in the ICAO Airport Services Manual, Part 9.
- ANSI/NFPA 79, Electrical Standards for Metalworking Machine Tools.
- National and local electrical codes and standards.

1.1.2 Intended Use



CAUTION

Use this equipment as intended by the manufacturer

This equipment is designed to perform a specific function, do not use this equipment for other purposes

- Using this equipment in ways other than described in this manual may result in personal injury, death or property and equipment damage. Use this equipment only as described in this manual.

Failure to follow this instruction can result in serious injury or equipment damage

1.1.3 Material Handling Precautions: Storage



CAUTION

Improper Storage

Store this equipment properly

- If equipment is to be stored prior to installation, it must be protected from the weather and kept free of condensation and dust.

Failure to follow this instruction can result in equipment damage

1.1.4 Material Handling Precautions: Fasteners



DANGER

Foreign Object Damage - FOD

This equipment may contain fasteners that may come loose - torque properly.

- Only use fasteners of the same type as the one originally supplied with the equipment.
- Use of incorrect combination of gaskets, bolts and nuts can create severe damages to the product installation and create safety risk .
- You need to know what base the light fixture will be installed in, in order to chose the correct gasket, bolts and nuts.
- Bolt type, length, and torque value are determined by type of base, height of spacers used, and clamp force required in FAA Engineering Brief No 83 (latest revision).
- Due to the risk of bolts vibrating loose, do not use any type of washer with the fixing bolts (such as split lock washers) other than an anti-vibration washer. Anti-vibration washers as defined in FAA EB 83 (latest edition) must be used. For installations other than FAA, use the base can manufacturer's recommendations.
- Always tighten the fasteners to the recommended torque. Use a calibrated torque wrench and apply the recommended adhesive type.
- Obey the instructions of the adhesives necessary for the fasteners.

Failure to follow these warnings may cause the fasteners to loosen, damage the equipment, potentially to loosen the equipment. This can lead to a highly dangerous situation of FOD, with potential lethal consequences.

Note

To minimize the risk of errors, the ADB SAFEGATE Sales Representative will have information on which gasket goes with which base. This information is also provided in the product Data sheets, the User Manuals and the Spare Part Lists.



CAUTION

Use of incorrect combination of gaskets, bolts and nuts can create severe damages to the product installation and create multiple safety risks.

To obtain a safe and watertight installation the O-ring and retaining bolt stated in the document must be used.

You need to know what base the light fixture will be installed in, in order to choose the correct gasket, bolts and nuts.

Failure to follow these cautions can result in equipment damage or aircraft FOD.

1.1.5 Maintenance Safety

DANGER

Electric Shock Hazard

This equipment may contain electrostatic devices

- Do not operate a system that contains malfunctioning components. If a component malfunctions, turn the system OFF immediately.
- Disconnect and lock out electrical power.
- Allow only qualified personnel to make repairs. Repair or replace the malfunctioning component according to instructions provided in its manual.
-



Failure to follow these instructions can result in death or equipment damage

1.1.6 Material Handling Precautions, ESD



CAUTION

Electrostatic Sensitive Devices

This equipment may contain electrostatic devices

- Protect from electrostatic discharge.
- Electronic modules and components should be touched only when this is unavoidable e.g. soldering, replacement.
- Before touching any component of the cabinet you shall bring your body to the same potential as the cabinet by touching a conductive earthed part of the cabinet.
- Electronic modules or components must not be brought in contact with highly insulating materials such as plastic sheets, synthetic fiber clothing. They must be laid down on conductive surfaces.
- The tip of the soldering iron must be grounded.
- Electronic modules and components must be stored and transported in conductive packing.

Failure to follow this instruction can result in equipment damage

1.1.7 Arc Flash and Electric Shock Hazard



DANGER

Series Circuits have Hazardous Voltages

This equipment produces high voltages to maintain the specified current - Do NOT Disconnect while energized.

- Allow only qualified personnel to perform maintenance, troubleshooting, and repair tasks.
- Only persons who are properly trained and familiar with ADB SAFEGATE equipment are permitted to service this equipment.
- An open airfield current circuit is capable of generating >5000 Vac and may appear OFF to a meter.
- Never unplug a device from a constant current circuit while it is operating; Arc flash may result.
- Disconnect and lock out electrical power.
- Always use safety devices when working on this equipment.
- Follow the recommended maintenance procedures in the product manuals.
- Do not service or adjust any equipment unless another person trained in first aid and CPR is present.
- Connect all disconnected equipment ground cables and wires after servicing equipment. Ground all conductive equipment.
- Use only approved ADB SAFEGATE replacement parts. Using unapproved parts or making unapproved modifications to equipment may void agency approvals and create safety hazards.
- Check the interlock systems periodically to ensure their effectiveness.
- Do not attempt to service electrical equipment if standing water is present. Use caution when servicing electrical equipment in a high-humidity environment.
- Use tools with insulated handles when working with airfield electrical equipment.

Failure to follow these instructions can result in death or equipment damage

2.0 L-852T(L) / ITEL-L

The ITEL-L LED in-pavement fixture can be used on taxiway edge, taxiway intersection and helipad applications. These fixtures have an average LED life of 100,000 hours under high-intensity conditions and more than 200,000 hours under actual operating conditions, resulting in significant reduction or even elimination of ongoing maintenance costs and periodic re-lamping expenses. The ITEL-L fixtures operate on either 3- or 5-step CCRs.

2.1 About this manual

Introduction

Provides the purpose, scope, and applicability of the technical manual.

The manual shows the information necessary to:

- Install and maintain the ITEL fixtures.
1. Become familiar with the structure and content.
 2. Carry out the actions completely and in the given sequence.

2.2 ITEL-L Product Introduction

The ITEL-L LED in-pavement fixture can be used on taxiway edge, taxiway intersection and helipad applications. These fixtures have an average LED life of 100,000 hours under high-intensity conditions and more than 200,000 hours under actual operating conditions, resulting in significant reduction or even elimination of ongoing maintenance costs and periodic re-lamping expenses. The ITEL-L fixtures operate on either 3- or 5-step CCRs.

2.2.1 LED In-pavement Taxiway Edge Light

Compliance with Standards

FAA:	L-852T(L) AC 150/5345-46 (Current Edition) and the FAA Engineering Brief No. 67. ETL Certified.
ICAO:	Annex 14, Vol. I, Ed. 6, para. 5.3.18.
CE:	Complies with the requirement of the EMC Directive 2004/108/EC.

Uses

- FAA L-852T(L)**
- Taxiway edge
 - Heliports

Electrical Supply

6.6 A through an L-830-1 (for 60 Hz) or L-831-1 (for 50 Hz) 30/45 W isolation transformer or an L-830-17 20/25 W isolation transformer. The ITEL fixture is designed to work with any IEC- or FAA-compliant transformer up to 100 W without affecting the performance or lifetime of the light fixture or transformer. See data sheet 3033 for more details on recommended isolation transformers specified below.

The total CCR load shown in the following table represents the total VA load imposed on the regulator and accounts for power factor and transformer load.

ITEL Fixture	Fixture Load	Isolation Trans-former	Heater On/Off	Trans-former Load	Total CCR Load
With arctic option	19.5 VA	30/45 W	Off	6 VA	25.5 VA
	44 VA	30/45 W	On	9 VA	53 VA
Without arctic option	19.5 VA	20/25 W	N/A	5 VA	24.5 VA

3.0 Installation

This section provides instructions for installing ITEL inset lights. Refer to airport project plans and specifications for the specific installation instructions. The installation shall conform to the applicable sections of the National Electric Code and local codes.



WARNING

Allow only qualified personnel to perform the following tasks. Observe and follow the safety instructions in this document and all other related documentation.

Failure to follow this instruction can result in injury or equipment damage.

3.1 Input Requirement Summary

The ITEL light fixture is designed for connection to a 6.6 A series lighting circuit via an L-830 isolation transformer. Refer to *Specifications* in the *Description* section for required isolation transformer.

3.2 Typical L-868 Assembly

Figure 1: Diagram of the Fixture Installed in a 1-Piece Base Can

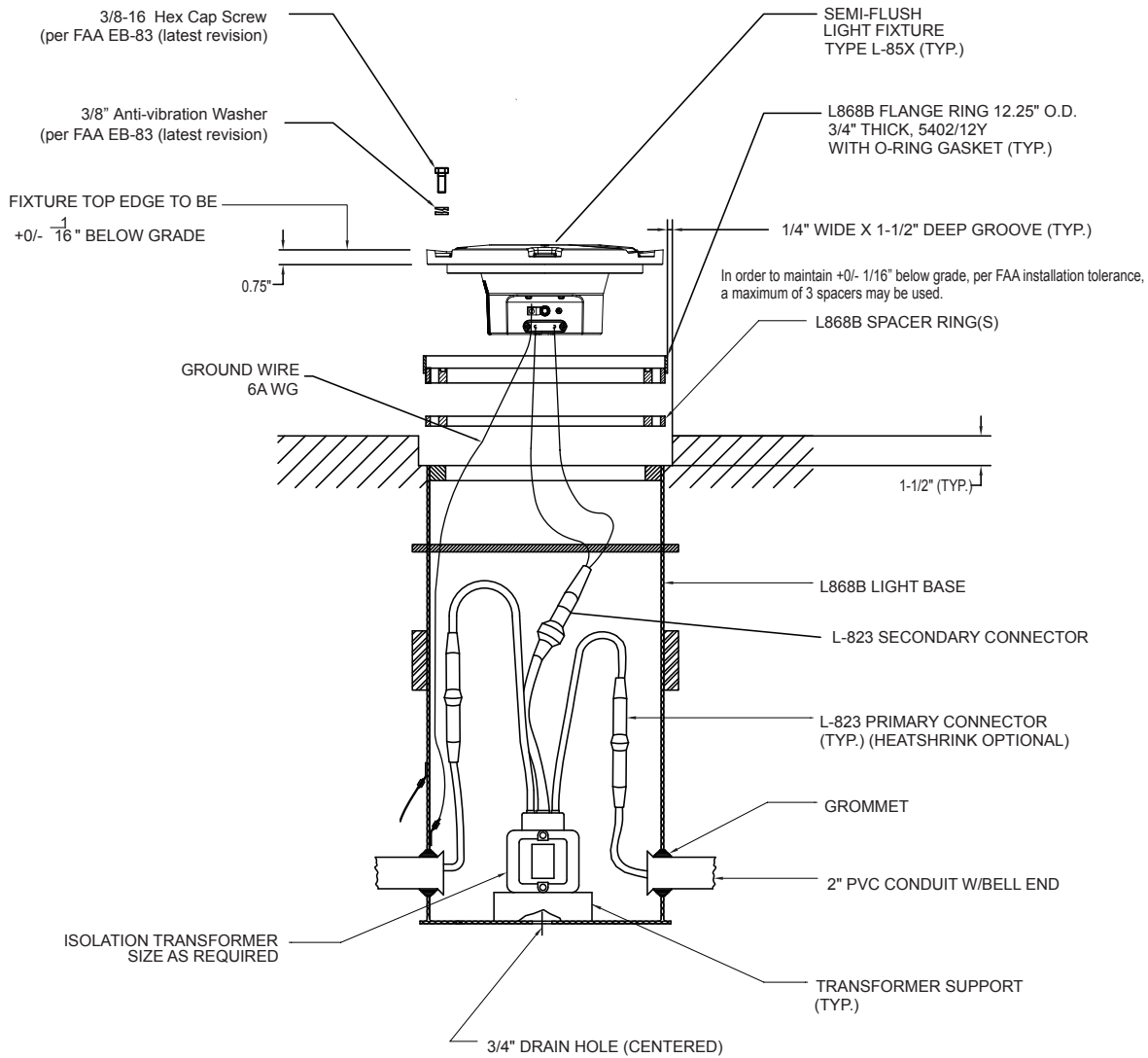

1. Torque according to: FAA EB-83 (latest revision).

Figure 2: Anti-vibration washer example

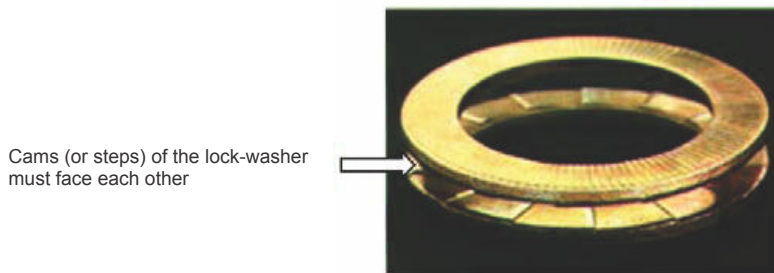

Cams (or steps) of the lock-washer must face each other



CAUTION

Per FAA AC 150/5340-30, Chapter 10, and FAA Engineering Brief No 83 (latest revision), it is extremely important that other types of washers, such as split washers, must not be used. Failure to use properly installed anti-vibration lock washers will cause mounting bolts to become loose. The cams (or steps) of each half of the lock washer must face each other.

3.3 Safety Considerations

Read the installation section of all system component manuals before starting these steps. A thorough understanding of system components and their requirements will promote safe and efficient installation. See FAA AC 150/5340-30, Design and Installation Details for Airport Visual Aids, and site plans and specifications for field installation of runway and taxiway in-pavement lights.



DANGER

Failure to follow these safety procedures can result in personal injury or death.

- Allow only qualified personnel to install ADB SAFEGATE and auxiliary equipment. Use only approved equipment. Using unapproved equipment in an approved system may void FAA approvals. Observe and follow the safety instructions in this document and all other related documentation.
- Make sure all equipment is rated and approved for the environment where it is being used.
- Follow all instructions for installing components and accessories.
- Install all electrical connections in compliance with local and national codes and regulations.
- Use only electrical wire of sufficient gauge and insulation to handle the rated current demand. All wiring must meet local and national codes.
- Route electrical wiring along a protected path. Make sure it will not be damaged by moving equipment.
- Protect components from damage, wear and harsh environmental conditions.
- Allow ample clearance for maintenance, panel accessibility and cover removal.
- Protect equipment with safety devices as specified by applicable safety regulations.
- If safety devices must be removed for installation, reinstall them immediately after the work is completed and check them for proper functioning.
- The cord set must be protected prior to installation.

3.4 Photobiological safety



CAUTION

Photobiological safety conforming with IEC 62471

RISK GROUP 0 or 1: Optical radiation emitted from LED lights may be harmful to the eyes. Do not stare with at the light source with bare eyes at a fixture operating at high intensity. Use protection goggles or similar protection method.

Goggles with a transmission factor not higher than 5% in the 400-530 nm band have been tested and provide adequate protection.

3.5 Verify Input Requirements and Equipment Needed

The In-pavement light fixture is designed for connection to a 6.6A or 20A series lighting circuit via an L-830 (60 Hz) or L-831 (50 Hz) isolation transformer.

Make sure you have the necessary tools and materials ready for installation (not supplied). Also consider other tools that might be needed based on site-specific conditions.

Table 1: Suggested Tools and Materials for Installation and Repair

Qty.	Description	Qty.	Description
1	Torque wrench	1	Set of screwdrivers, one with 3/8" (9.525mm) minimum blade width
1	Alignment jig		
1	Diamond-faced core drill	As needed	Silicone grease
1	Diamond-faced saw, 3/8" (9.525mm) thick	As needed	Joint sealing filler
1	Crimping tool	1	Pressure test fitting assembly
1	Small water suction pump	As needed	Dow Corning Molykote® 3452 or equal (P/N 67A0095) - used on top cover prism seal
2	Eyebolts, 3/8 inch (9.525mm) diameter		
1	Lifting rod, 16 inches (406mm) long	As needed	Novagard® Silicone Versilube® G322L™ (P/N 67A0009) - used on O-ring between top cover and inner pan assembly; also may be applied to four nipples of inner pan assembly to install optical assembly
1 or 2	L-830 / L-831 isolation transformer		
1	Set of fiber brushes		
1	Set of socket wrenches, 1/2" (12.7mm) drive		

3.6 Unpacking the Unit

To reduce the possibility of damaging the light assembly, unpack the light fixtures at the installation site. If damage to any equipment is noted, file a claim form with the carrier immediately.

When receiving the light fixture, open the box and verify that the characteristics of the light fixture correspond to the design requirements, such as type, color etc. When installing a light fixture where the control and monitoring function is to be activated at a later stage, make sure to register product information, such as PID/SN and position of the light fixture in, for example, a site documentation table. The information is required for remote activation and administration of control and monitoring functionality from a substation.

3.7 Inspect on delivery

1. Inspect all packings for visible damage.
2. Open every damaged box and inspect the contents for damage.
3. Immediately fill a claim form with the carrier if any fixture is damaged.
4. Store the fixture in its original packing in a protected area.



Note

If damage to any equipment is noted, file a claim form with the carrier immediately.



WARNING

Do not damage the cable insulation.



CAUTION

Do not unpack the fixture before it is at the installation site to avoid damage due to transportation and handling.

3.8 Store

Store the fixture in its original packing in a protected area. Indoor storage:

- Storage temperature: 14°F to 122°F (-10°C to +50°C).
- Humidity: <95% non condensing.

For long storage periods (longer than one year), we recommend to energize the LED lights once a year at nominal intensity (6.6 Amps) for 20 minutes.

3.9 Installation on L-868 Base

The light assembly is shipped complete, and is ready for installation.

To install the fixture on an L-868 base, see FAA AC 150/5345-30 and the project site-specific plans and specifications for details on L-868 base installation.

Note

Mounting bolts are not supplied with the fixture. Mounting bolts and anti-rotation lock washers are normally supplied with the base can spacer or flange ring. If a flange ring is used, the bolt length is 1-1/4 inch (32mm) plus the thickness of the flange ring.

Also read the following guidelines:

1. Clean the base receptacle. Make sure the base receptacle is completely clean and dry. The mating surfaces must be clean and free of foreign particles.
2. If, present, fit an appropriate lifting tool into the two threaded holes, which are located 180° apart in the cover.



The lifting tool can be made from two 1/2 x 13 eyebolts (1-inch ID) and a 1/2-inch diameter, 16-inch (406mm) long rod or pipe inserted through the eyebolts.



CAUTION

Never hold the light fixture by the wires. Doing so may damage the insulation, break the waterproof seal and cause insulation faults and water leakage.

3. Carry the light assembly to the base.
4. Place the light assembly next to the opening in the L-868 base so that the L-823 connector can be connected with the mating receptacle from the L-830 or L-831 isolation transformer in the base. Make sure that the connection is solid and secure. Refer to the Electrical Supply section of the User manual for required isolation transformers.
5. Make sure items such as spacers, shims and gaskets are installed on the light base as indicated on site plans, specifications and drawings.
6. Position the light assembly over the L-868 base and set it onto the base. Align the light according to FAA AC 150/5345-30 and project plans and specifications. Remove the eyebolts and lifting rod.



CAUTION

Ensure that the cord set wires are NOT pinched between the base can and the fixture. Pinched wires can cause water to be drawn inside the fixture.

7. If present, lubricate the labyrinth gasket with water. soap may be added to the water (8" only).

**CAUTION**

Do not use silicon or any other type of grease. Avoid the use of soap that contains silicon or glycerin.

8. Attach the six fixing bolts and anti-vibration washers. [See FAA EB-83 (latest revision)]

**CAUTION**

Due to the risk of bolts vibrating loose, do not use any type of washer with the fixing bolts (such as split lock washers) other than an anti-vibration washer. Anti-vibration washers as defined in FAA EB-83 (latest revision).

9. Turn on the power to determine whether the fixture will illuminate. Operate for a minimum of five minutes.

3.10 Installing Adapter Ring

To install the adapter ring, perform the following procedure:

- Single Piece Adapter Ring Mounting.** If mounting the adapter ring on to a L868 light Base, align the outer set of bolts holes with the mating tapped holes in the flange of the light base. Install and tighten the mounting bolts to fasten the adapter ring to the light base. See following notes on using thread locking compounds, and torque specifications in FAA EB 83 (latest revision) for bolt torquing procedures.
- Install the two anti-rotation pins into the two tapped holes in the inner bolt circle **before installing the optical assembly.** See Figure 8 for the location of the anti-rotation pins.
- Segmented Adapter Ring Mounting.** If mounting a two-piece segmented adapter ring on to a L867D light Base use a 7/16 drill and drill-out the (6) 3/8-16 tapped holes in the flange of the L-867 light base. After the holes have been drilled- out each of the adapter ring segments can then be turned sideways and slipped through the 8-inch opening in the L867 light base and brought up against the underside of the flange of the light base. Fasten the segmented rings to the light base flange by using three Allen Soc Head or Button Head screws supplied with the adapter ring.
- After installing both rings install the two anti-rotation pins 180 degrees apart.
See Figure 8 for the location of the anti-rotation pins in the segments of the adapter ring. See the following notes on using thread locking compounds, and torque specifications in FAA EB 83 (latest revision) for bolt torquing procedures.

Figure 3: Adapter Ring

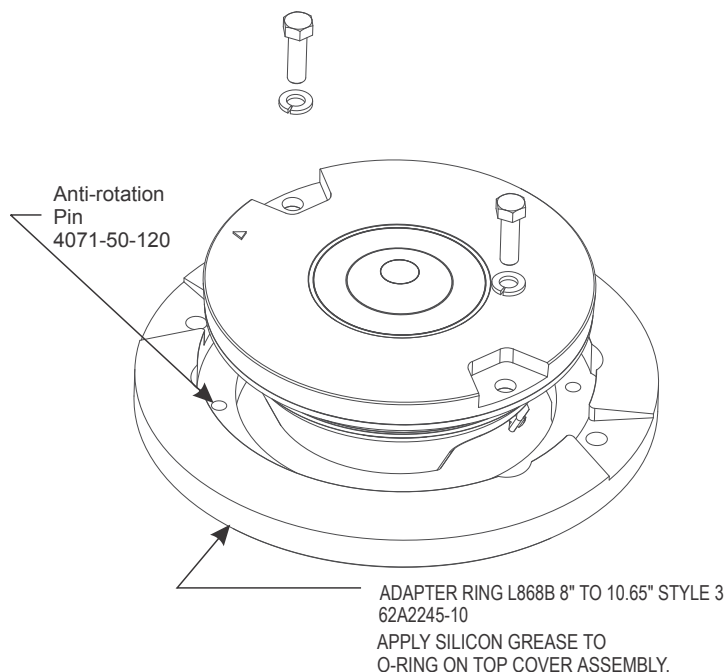

3.11 Adapter Ring Mounting and Connection

To mount and connect the light assembly, perform the following procedure:



CAUTION

Make sure not to drop the light assembly or to pinch the wires when mounting the light on the adapter ring. Failure to follow this instruction can result in equipment damage.

1. Connect the isolation transformer secondary receptacle to the L-823 plug of the inset light.
Apply insulating tape around the plug and socket assembly.
2. Orientate the light assembly so that the two blind holes in the underside of the flange are aligned with the two anti-rotation pins in the adapter ring.

See [Figure 8](#) for details on adapter rings. Install the light assembly into the adapter ring and secure with two 3/8-16 hex head bolts. See [Figure 4](#)

Figure 4: Assembly to L-868 Adapter Ring

Adapter Ring
Mounting Bolt Holes,
6 Places 60 Degrees
Apart

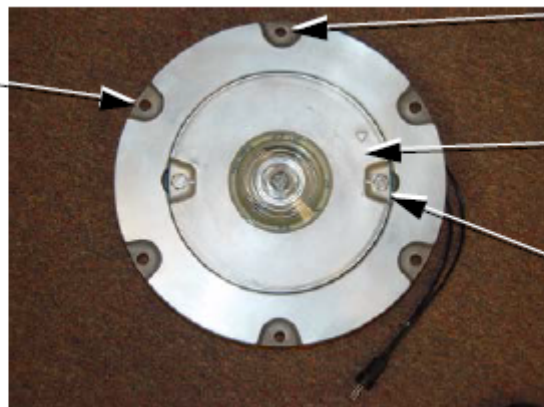

Taped hole for 1/2-13
Eye Bolt – 2places
180 Degrees Apart

Optical Assembly
Mounting Bolt Holes, 2
Places 180 Degrees
Apart

Optical Assembly Blind
Hole Located on
Underside for anti-
rotation pins 2 Places
180 Degrees Apart

3.12 Torquing and Installation Guidance for In-pavement Fixtures

In-pavement fixtures must be installed according to the plans and specifications; the applicable regulatory guidance; and the following guidance. The importance of using the proper fixture clamping components and bolt torque to minimize the risk for fixture failure or loosening of clamping components cannot be overemphasized. Refer to FAA Engineering Brief No 83 (latest revision) for torque and installation guidelines for this fixture.

Also see our Product Center at www.adbsafegate.com.



CAUTION

Read installation instructions in their entirety before starting installation.

- Failure to follow the installation guidance could result in bolt loosening or bolts breaking off, resulting in catastrophic failure of the fixture and/or the mounting system components.
- Failure to follow these warnings may result in serious injury or equipment damage.

3.13 Shallow base can installation

Shallow base cans may be non-load bearing or load bearing depending on location or fixture application. Following are specific requirements to insure that an either an elevated or an in-pavement fixture is properly installed.



CAUTION

Read installation instructions in their entirety before starting installation.

Fasteners:

- Make sure the power is OFF when you install or remove any fixture.
- Only use fasteners of the same type as the one originally supplied with the mounting support. See Base O-ring and Bolt Selection.
- Always tighten the fasteners to the recommended torque. Use a calibrated torque wrench and apply the recommended adhesive type.
- If this is not the case, this may cause the fasteners to loosen, damage the fixture, potentially to loosen the fixture. This can lead to a highly dangerous situation of FOD, with potential lethal consequences.
- Obey the instructions of the adhesives necessary for the fasteners.
- Only install the fixture on mounting supports:
 - That ADB Safegate has approved;
 - That are installed according to the Instruction Manual of the mounting support.
- Failure to do so can result in a highly dangerous situation of FOD, with potential lethal consequences.

Failure to follow these warnings may result in serious injury or equipment damage.



CAUTION

Proper Operation:

- The fixture is supplied from a 6.6 A series circuit;
 - The series circuit is powered by a Constant Current Regulator that complies with IEC 61822;
 - The transformer is an AGL series transformer that complies with IEC 61823.
 - The power of the series transformer shall not exceed 200 W, for versions with the monitoring option.
 - The mounting support is correctly earthed. Failure to do so will void the warranty for all damages that occur as a result of voltage surges.
 - Never hold the fixture by the cable leads. This can damage the insulation, break the waterproof seal and cause insulation faults and water leakage.
-



Note

See the Instruction Manual of the mounting support for instructions on how to earth the mounting support.

3.13.1 Installation on a Shallow Base

Installing the light fixture on a shallow base involves preparing the pavement recess and wireways, then installing the light fixture on a shallow base.

See FAA AC 150/5345-30 and the project site-specific plans and specifications for details on shallow base installation.

Also follow the applicable instructions in the previous section, when connecting, installing and powering the fixture.

Figure 5: Example of a Shallow Base Installation

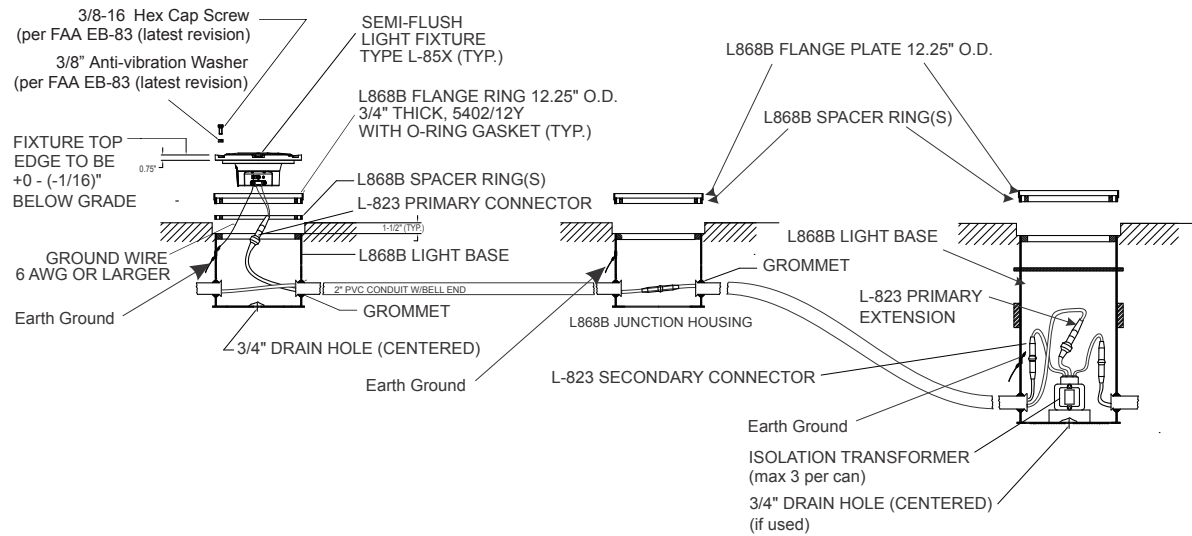

1. Torque according to: FAA EB-83 (latest revision).

Figure 6: Anti-vibration washer example

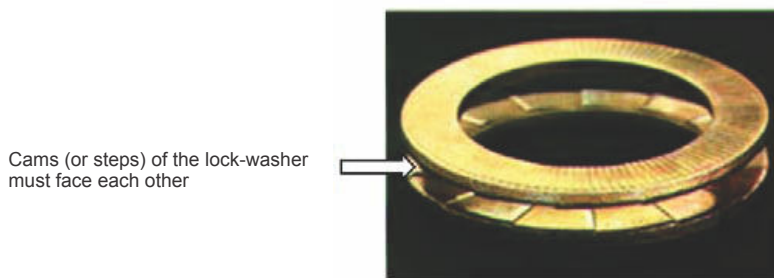

Cams (or steps) of the lock-washer must face each other



CAUTION

Per FAA AC 150/5340-30, Chapter 10, and FAA Engineering Brief No 83 (latest revision), it is extremely important that other types of washers, such as split washers, must not be used. Failure to use properly installed anti-vibration lock washers will cause mounting bolts to become loose. The cams (or steps) of each half of the lock washer must face each other.

4.0 Maintenance

This section provides maintenance information and procedures for the ITEL light fixtures.

4.1 Maintenance Schedule

Service life depends upon the entire assembly being waterproof. All surfaces must be clean, dry and free of all foreign matter and all bolts must be properly tightened if the light fixture is to operate for extended periods without requiring maintenance.

To keep the ITEL light fixtures operating efficiently, follow a preventive maintenance schedule. Refer to [Table 2](#). Refer to FAA AC 150/5340-26 for more detailed information.

Table 2: F-Range Light Fixture Maintenance

Interval	Check	Action
Daily	Low light output	Clean outer surface of prism if dirty. Refer to <i>Cleaning Light Channel and Lens</i> this section. Check for presence of moisture in fixture.
Weekly	For obstruction in light output channel	Clean prism surface. Refer to Cleaning the Lens this section.
Monthly (or more frequently during rainy seasons)	For presence of moisture or water (visual inspection for condensation on inner side of prisms)	Open up light assembly. Clean, dry, and inspect light assembly. Replace cover/inner cover gasket and other parts found defective. Replace LED assembly. Refer to Replacing LED Assembly in the <i>Repair</i> section.
Bimonthly	Torque on hold-down bolts	Torque six bolts holding fixture to base. Refer to <i>Torquing Mounting Bolts</i> in this section. Refer also to <i>Installation on L-828B Base</i> in the <i>Installation</i> section.
Semi-annually (or more frequently during rainy seasons)	For six inches (152 mm) of water in the L-868B base	Pump water from base. Remove and inspect light for water damage. Refer to <i>Removing L-868 Base Water</i> in this section.
After snow removal	For damaged light fixtures	Replace damaged fixtures. Use a power broom for snow removal, if practical.

4.2 Removing L-867 and L-868 Base Water



WARNING

Turn off the circuit when checking water level.
Failure to follow this instruction can result in injury or equipment damage.

Check the water level in the L-868B base on a regular schedule. If more than six inches (150 mm) of water in the light base is found, pump the water from the base and remove and inspect the entire light assembly for water damage. Cover the light base with the appropriate steel cover plate after removing the light assembly.



CAUTION

Water entering the light base can become a serious problem, since freezing water can rupture the base.

4.3 Bolt Torque Preventive Maintenance Schedule

An established schedule for checking light fixture bolt torque and bolt condition is mandatory. This is particularly true for areas that are subject to high impact loads from aircraft such as runway status lights, runway touchdown zone lights, runway centerline lights, and taxiway lead-off lights. Although AC 150/5340-26 offers a recommended schedule for periodic checks, these checks should be tailored to the facility based on local conditions such as environmental issues and runway traffic load.

1. Torque according to: FAA Engineering Brief No 83 (latest revision).

Figure 7: Anti-vibration washer example

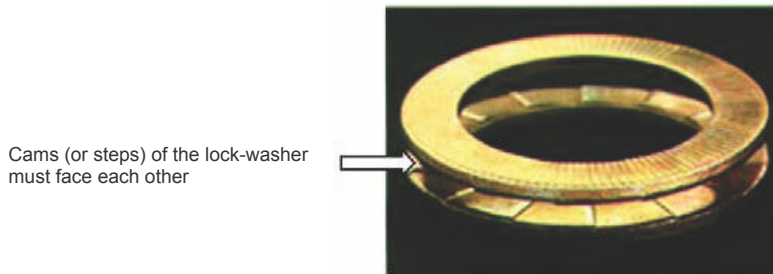

CAUTION

Per FAA AC 150/5340-30, Chapter 10, and FAA Engineering Brief No 83 (latest revision), it is extremely important that other types of washers, such as split washers, must not be used. Failure to use properly installed anti-vibration lock washers will cause mounting bolts to become loose. The cams (or steps) of each half of the lock washer must face each other.

FAA Cert Alert No. 14-03 refers to AC 150/5340-26 for the frequency of checking bolt torque. AC 150/5340-26 (latest revision) paragraph 5.3.4.1.4, *Bi-Monthly Checks* states: "The torque of the bolts attaching the light fixture to its base should be checked with a calibrated torque wrench – never use an impact wrench."

Regular inspection as outlined in FAA Engineering Brief 83 (latest edition), Canada Civil Aviation Safety Alert Document CASA 2014-05, and any other applicable regulatory guidelines is critical in insuring torque on all bolts is restored to optimum values. Bolts that loosen more often should be inspected and re-torqued on a more frequent basis.

It is especially important to maintain a regular inspection schedule for LED fixtures. Since LED fixtures operate more reliably and are not subject to removal/replacement/re-torque as frequently as would be seen with incandescent fixtures, it is even more important to implement regular torque inspections.

It is critical that remedial action be taken if bolts are found to be loose or missing during inspection. If this occurs, it is important to carefully inspect all structural elements of the mounting system as defined in Installation. Also inspect the base can for general structural conditions such as:

- Is the base can solidly mounted in the pavement, and not moving or rocking during rollovers?
- If a base can extension is present, are all extension attachment bolts tight?

If poor base can structure or mounting system components are not in accordance with regulatory requirements or are in poor condition, it is the airport's responsibility to:

- Increase the frequency of bolt torque inspection to insure that no bolts become loose or missing.
- Quickly replace/repair the mounting system components, which may include replacing the entire base can.

Airport operators must also ensure these maintenance activities are properly documented.

Digital Asset Tracking and Service Application Information

ALIS is ADB SAFEGATE's new digital asset tracking, inspection and service solution, helps airports easily register airside assets, electronically schedule and track maintenance, and record maintenance and inspection tasks in compliance with ICAO and FAA standards.

Easy to implement and use, cloud-based software enables a more reliable and fail-safe approach to asset tracking and maintenance by always using live field data and eliminating inefficiencies caused by human error. Every asset is registered using GPS data and its status recorded, so airport maintenance teams get a clearer view of maintenance schedules and history, allowing them to manage resources more effectively as well as improve the safety and longevity of airside assets. This increased visibility helps airports plan and schedule preventive maintenance, or undertake corrective maintenance more quickly, to reduce downtime and significantly improve operational availability.

<https://adbsafegate.com/product-center/airfield/airside-services/ALIS-airside-maintenance>

- Easily integrates electronic torque measurements and photometric measurement reports to provide a complete view of the asset's status.
- ALIS can be integrated with the AirTorque or Ingersoll Rand® QX series wrenches, which are used for accurate, ergonomic torque inspections of AGL fixtures. The applied torque can seamlessly be registered in the ALIS system as a part of the maintenance record.
- The iPhone application of ALIS – ALIS Personal – makes it easier than ever to register maintenance actions while working. It will proactively show you which assets you still need to work on and select the closest one to you automatically. ALIS Personal acts as a feedback and information device for the associated torque wrench.

5.0 Troubleshooting



WARNING

Allow only qualified personnel to perform the following tasks. Observe and follow the safety instructions in this document and all other related documentation.

De-energize the circuit and lock out the circuit or regulator so that the circuit cannot be energized by remote means before attempting to service the fixture.

Failure to follow this instruction can result in injury or equipment damage.

This section contains troubleshooting information. This information covers only the most common problems that you may encounter. If you cannot solve the problem with the information given here, contact your local ADB Safegate representative for help.

Troubleshooting procedures for the inset lights are contained here.

Table 3: Troubleshooting Procedures

Problem	Possible Cause	Corrective Action
1. LED not energizing	LED defective ITEL PCB defective	Replace Optical LED assembly. Refer to Replacing LED Assembly . Replace the PCB See : Testing an LED assembly .
	Loose LED leads	Replace Optical assembly
	Moisture inside assembly causing current leakage	Open up light assembly. Clean, dry, and inspect light assembly. Replace the O-ring.
	No connection of primary circuit. Defective L-830 isolation transformer or secondary wiring	Check transformer output current with true RMS ammeter. Check power line between the light fixture and the transformer, including connectors.
2. Weak light output	Partial short circuit in primary loop	Check cable assembly.
	Defective L-830 isolation transformer	Replace transformer.
	Dirty lens	Clean lens. Refer to Cleaning the Lens .
3. Light beam distorted	Broken or damaged lens /cover	Replace lens or entire fixture. Refer to Replacing Lens and Lens Gasket .
4. Short LED life	Current too high	Check output current of isolating transformer at full brightness. Current should not exceed 6.7 A. Replace transformer if defective; if not, adjust CCR output current.
	Moisture in lighting fixture	<ol style="list-style-type: none"> 1. Open light assembly. Refer to <i>Opening optical assembly</i> in the <i>Repair</i> section. 2. Check for cause of leakage (dirty or damaged o- ring seal mating surfaces, defective lens seals, cracked or broken lens, loose screws or damaged wire insulation). 3. Clean, dry, inspect, or replace damaged components.



Note

If the blue LED light engine needs to be replaced on ITEL-1XXX fixtures shipped prior to June 2012, both the LED light engine and the LED PCB must be replaced with the new part numbers shown in the spare components list.

5.1 Repair

This section describes procedures for repairing and replacing parts.

It includes opening the optical assembly, and replacing the LED assembly, and prism and prism gasket. It also describes how to close the optical assembly.



Note

If the cordset needs servicing, contact the ADB Safegate Sales department.

5.1.1 Lifting Optical Unit From Base

To lift the optical unit from the light base, perform the following procedure:

1. Remove both fixing screws and washers or self locking nuts.
2. See [Figure 4](#) and [Figure 1](#).
Fit the appropriate lifting tool into both holes located (180° apart) in the cover, lift the optical unit out of the base and place the optical unit next to the base.
3. Disconnect the light fixture wires from the power wires coming from the transformer(s).
4. Mount a serviced or new light fixture as described in ["Installation on L867D or L-868B Base"](#).



CAUTION

Never hold the light fixture by the wires. This may damage the insulation, break the waterproof seal, and cause insulation faults and water leakage.

Failure to follow this instruction can result in equipment damage.

5. Take the inset fixture unit back to the maintenance base where it can be serviced entirely.

Figure 8: Mounting Bolts – Single Piece Adapter Ring for L868B

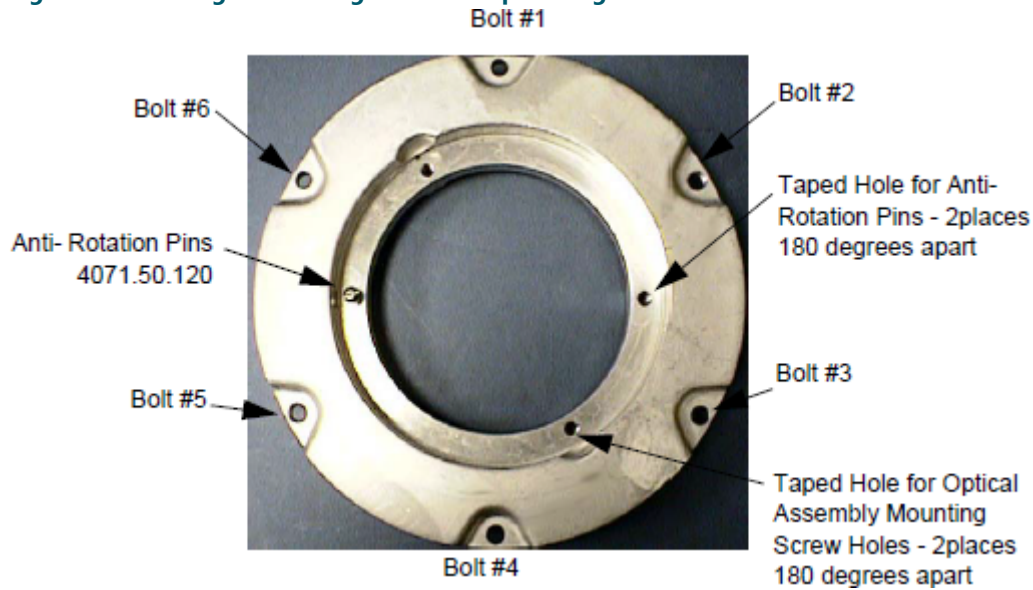
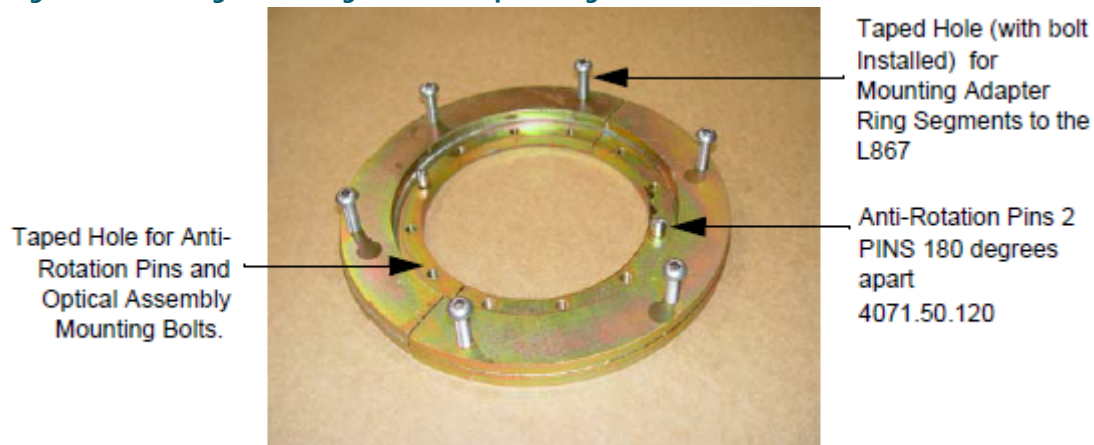

Figure 9: Mounting Bolts – Segmented Adapter Ring for L867D



5.1.2 Opening Assembly

To open the optical assembly, perform the following procedure:

1. Turn the light unit upside-down.
2. See [Figure 10](#).

Remove the pressure release screw (2). This relieves any built-up internal pressure and makes it easier to remove the inner cover.

Figure 10: Removing Pressure Release Screw

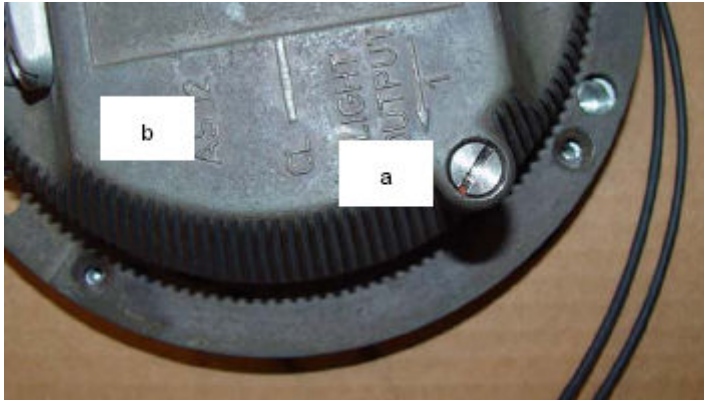

- a. Pressure Relief Screw
- b. Inner Cover Assembly

3. Remove the four Phillips pan head screws that fasten the inner cover to the top cover.
The use of an impact driver may be required to unlock the screws.
4. Carefully lift off the inner pan (2) from the cover, taking care not to damage the wire connection between the main PCB and the LED assembly.



Note

If the inner pan does not separate from the cover assembly easily, use a flat bladed screwdriver to separate it by inserting the screwdriver blade in the pry slots. There are 2 slots 180 degrees apart milled into the underside flange of the top cover that mates with the inner cover flange. See [Figure 12](#).



CAUTION

Be careful. Do not pull on the LED lead cable when you lift the inner pan.
This may damage the connection!
Failure to follow this instruction can result in equipment damage.

-
5. See [Figure 11](#).

Disconnect the LED Optical Assembly from the main PCB by pulling on the quick disconnect on the PCB. If necessary use a small flat screwdriver to separate the quick disconnect from the terminal on the PCB.

i Note

If the blue LED light engine needs to be replaced on ITEL-1XXX fixtures shipped prior to June 2012, both the LED light engine and the LED PCB must be replaced with the new part numbers shown in the spare components list.

Figure 11: Disconnecting LED Optical Assembly

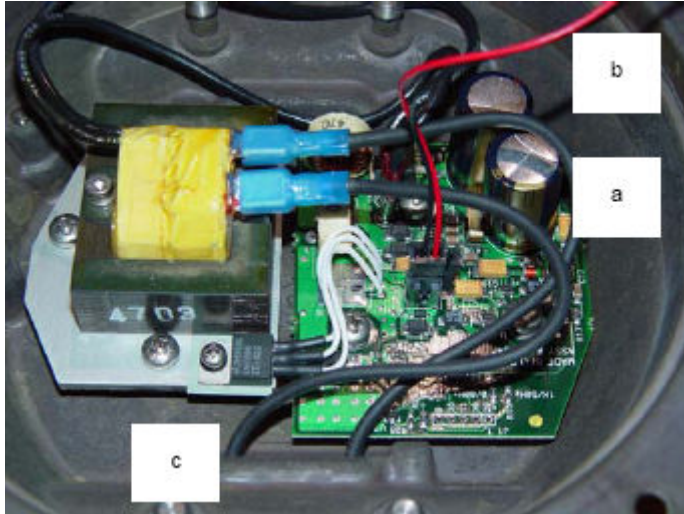

- a. LED Disconnect on PCB
 - b. LED leads from Optical Assembly
 - c. L-823 Disconnect
6. Remove the inner pan from the cover.

i Note

See Figure 12. Always replace the cover/inner cover O-Ring seal Item (a) whenever the inset fixture is opened. This guarantees light fixture water tightness.

Figure 12: Replacing Cover/Inner Cover O-ring Seal

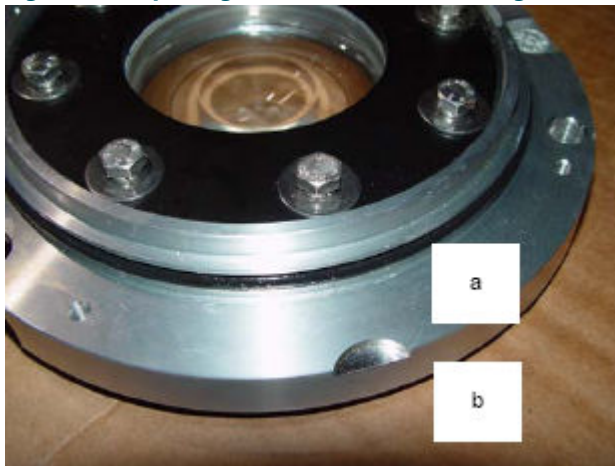

- a. O-Ring seal
- b. Screw Driver Pry Slot

5.1.3 Cleaning the Lens

To clean the prism, perform the following procedure:

1. Clean the outer surface of the lens using liquid glass cleaner.
If the prism is coated with a substance impervious to the cleaner, apply a suitable solvent sparingly with a wad of cotton or a patch of cloth.
2. After the solvent has acted, remove the softened coating with a clean piece of cotton or cloth.
3. Dry the prism with gently, dry, oil-free compressed air at a pressure no greater than 10 psi (69 K•m²) to evaporate or remove all remaining cleaner.

5.1.4 Testing an LED assembly

For this test, use a Fluke 87 or equivalent meter.



CAUTION

Do not use the megger function or a resistive test of any meter on an LED assembly! This may damage the LED's properties required for proper operation.

This test only works for LED assemblies of one or two LEDs. Three or more LED assemblies require a different testing method not covered here.

Failure to follow these instructions can result in equipment damage.

A "Diode Test" function may be used as a quick pass/fail check on an LED. In the maintenance shop, open the fixture and unplug the LED assembly.

1. Set the meter to test a DIODE.
2. Connect the meter leads to the LED assembly.
Observe if the LEDs glow and also note the meter reading of the LEDs.
3. Then reverse the meter leads and observe the LEDs again.



Note

With good LEDs when forward biased, the LEDs will glow dimly and the meter will indicate a low resistance. When the LEDs are reverse biased, the LEDs will not glow and the meter will indicate a high resistance.

4. Test a known, good LED assembly in the same manner to verify your meter’s operation and typical meter indications.

Figure 13: Diode testing an LED assembly with a Fluke 87 Meter

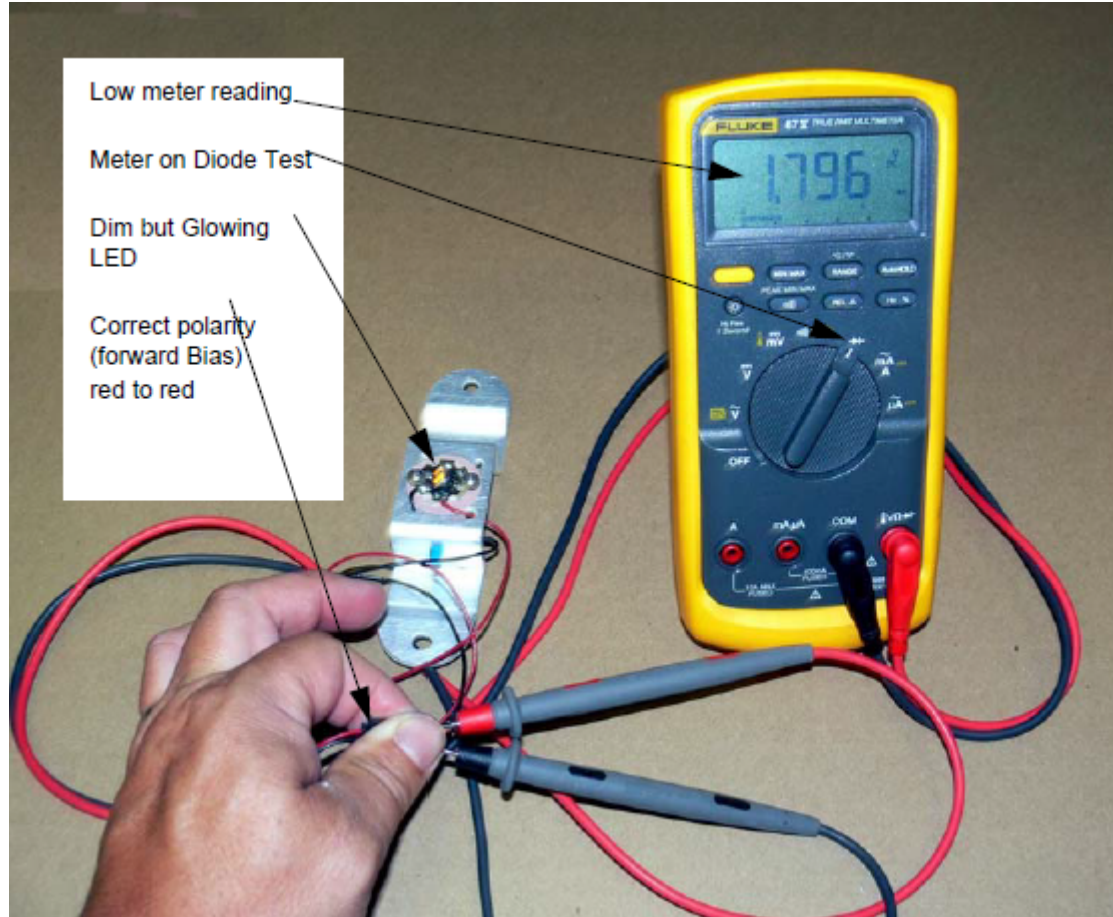

5.1.5 Replacing LED Assembly



WARNING

Turn off the circuit before replacing LEDs. Failure to observe this warning may result in personal injury, death, or equipment damage.

Failure to follow this instruction can result in injury or equipment damage.

Refer to [Table 4](#) for parts referred to in [Figure 14](#) and [Figure 15](#).

Table 4: Parts List for Replacing LED Assembly

Item	Description	Part Number	Quantity	Note
Figure 15	LED assembly	44A7177/XX	1	
Figure 14	LED ITEL Top Cover Assembly	4071.76.002		

To replace the LED assembly, perform the following procedure:

1. Open the light assembly.

Refer to [Opening Assembly](#).

2. See [Figure 14](#).

Unscrew the two M6 hex head screws that fastens the LED Optical Assembly bracket to the top cover.

3. Disconnect the LED leads from the PCB and remove and discard the existing LED Optical Assembly.
See [Figure 11](#).

4. Install the new LED Optical Assembly (purchased as a complete assembly) See [Figure 15](#) and torque screws to 75 +/- 5 In-lbs.

Re-connect the LED lead to the terminal on the PCB.

5. Re-install the inner cover assembly to the top cover using the 4 flat head screws.

Apply a droplet of Loctite 222 to the last threads. Torque screws to 2.5 ±0.5 Nt-m (22 ±4 inch-pounds).



Note

If the blue LED light engine needs to be replaced on ITEL-1XXX fixtures shipped prior to June 2012, both the LED light engine and the LED PCB must be replaced with the new part numbers shown in the spare components list.

Figure 14: Optical Assembly Removal

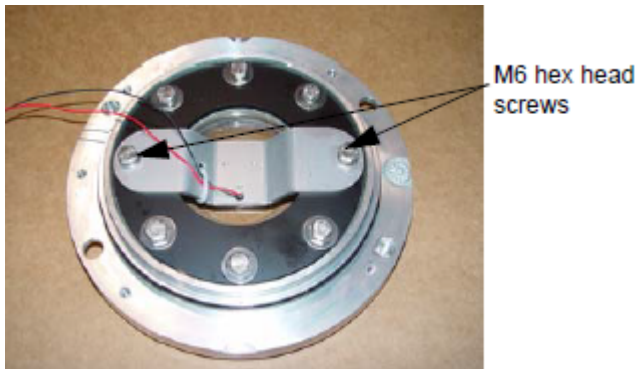

Figure 15: LED Optical Assembly



Wiring Diagrams:

Figure 16: Wiring for 44A6612-1X

**CONNECTIONS FOR ITEL PAN ASSY
44A6612/1X**

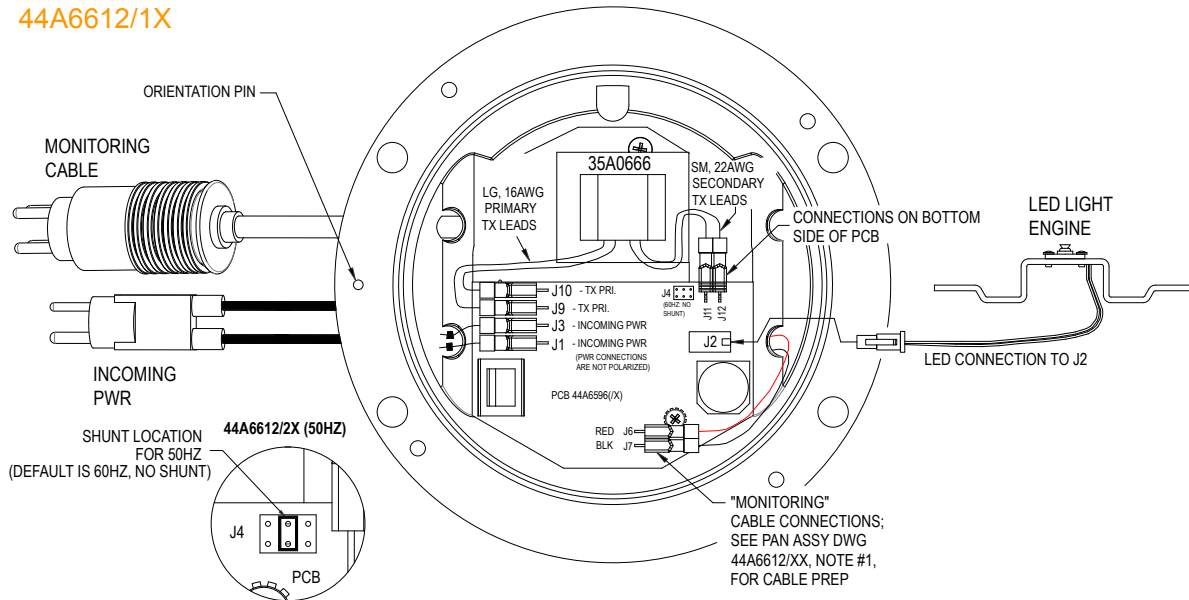

Figure 17: Wiring for 44A6612-2X

**CONNECTIONS FOR ITEL PAN ASSY
44A6612/2X**

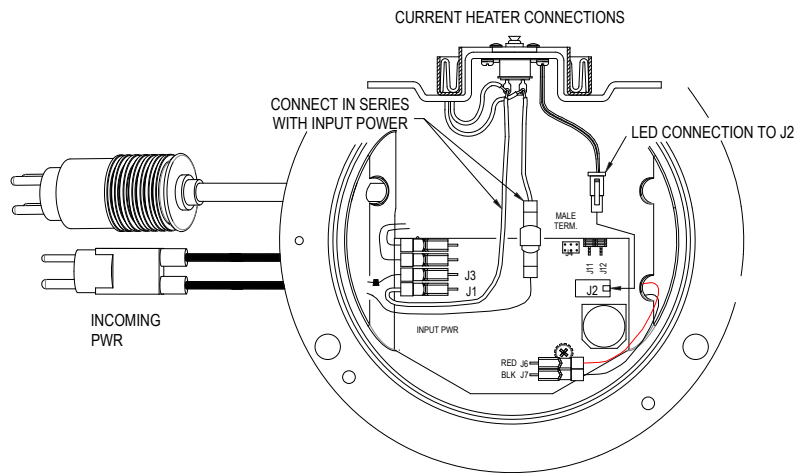
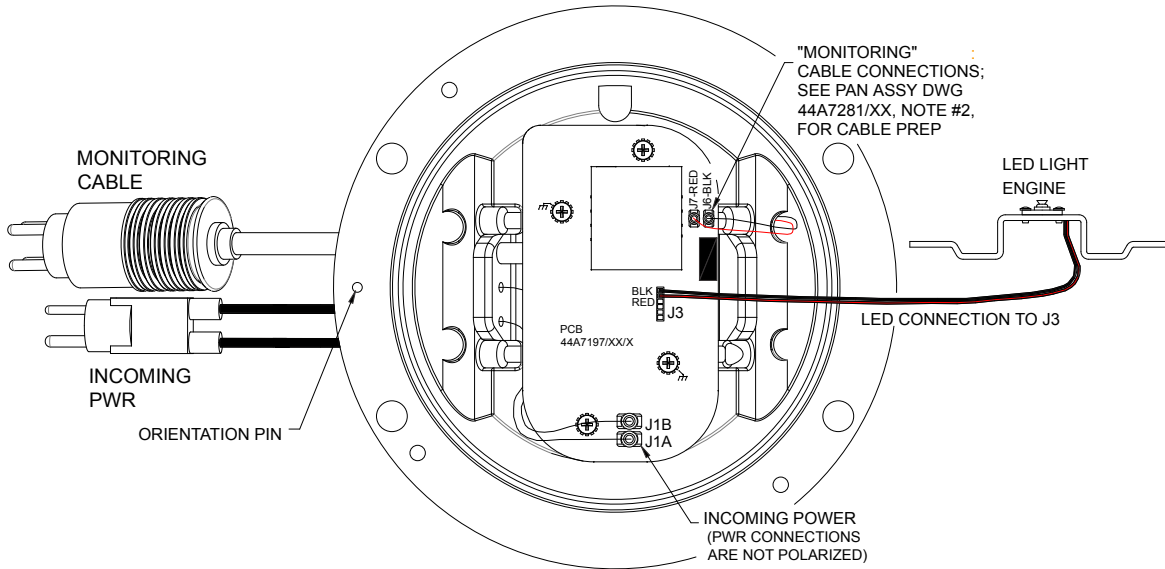

Figure 18: Wiring for 44A7281-1X

**CONNECTIONS FOR ITEL PAN ASSY
44A7281/1X**



FOR "50HZ" 44A7281/2X,
USE PCB 44A7197/50/X
(NO SHUNT REQ'D)

Figure 19: Wiring for 44A7281-2X

**CONNECTIONS FOR ITEL PAN ASSY
44A7281/2X**

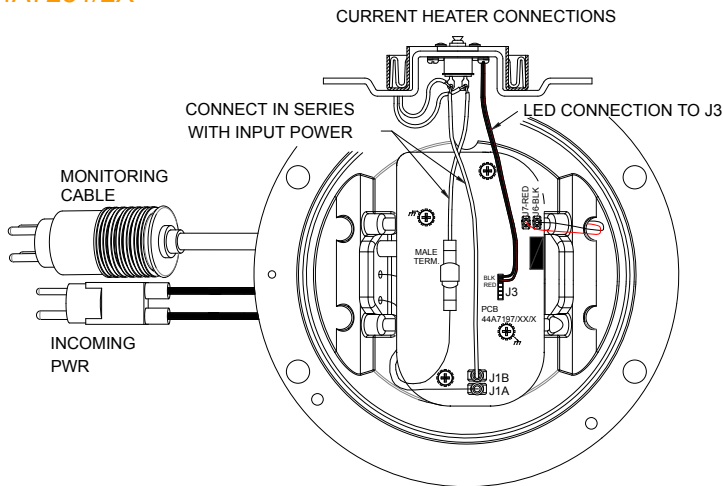
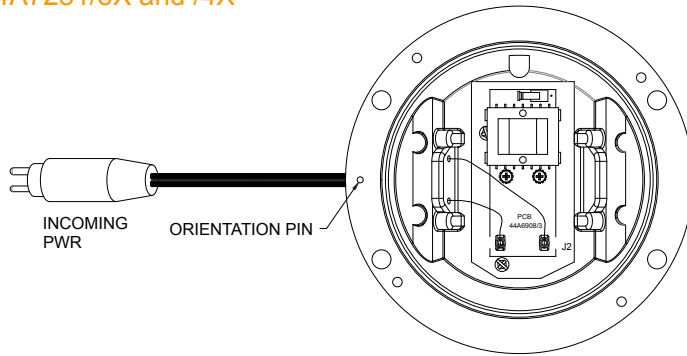

Figure 20: Wiring for APS

**CONNECTIONS FOR ITEL/APS PAN ASSY
44A7281/3X and /4X**



5.1.6 Replacing Lens and Lens Gasket

Refer to Figure 21.

Table 5: Parts List for Replacing Lens and Lens Gaskets

Item	Description	Part Number	Quantity	Note
Figure 25	Lens Gasket (molded)	4071.76.041	1	
Figure 24	Lens, L861T	63A1071	1	
Figure 24	Lens flat gasket protection	61A0539	1	

Figure 21: For /X3X0 (Without Heater) Top Cover

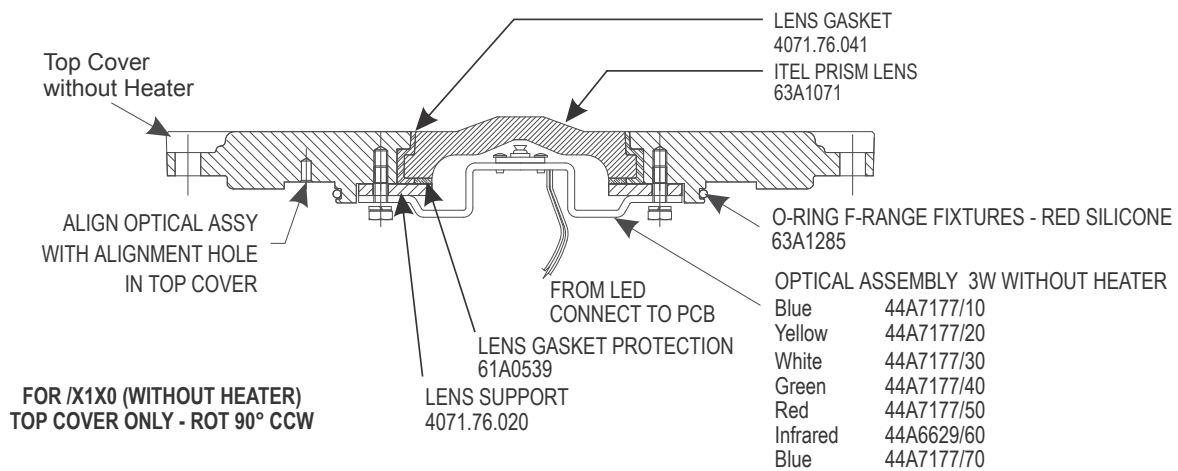
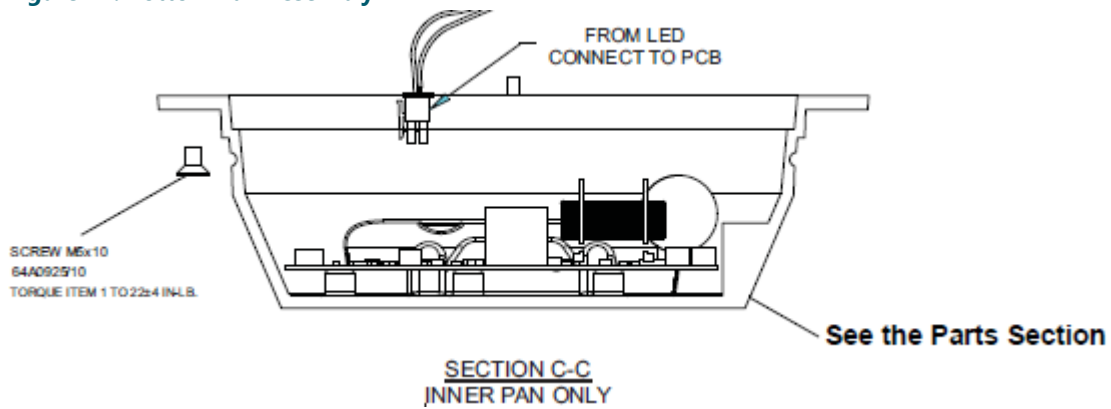

Figure 22: Bottom Pan Assembly



Replace the lens if it is broken or its surface is badly pitted or scarred.

To replace the lens and lens gasket, perform the following procedure:

1. Open the light assembly.

Refer to *Opening Light Assembly* in this section.

2. See [Figure 23](#).

Unscrew the eight M6 metric Hex Head Cap Screws and then remove the LED bracket and the lens support plate.



Note

The two M6 Hex Cap Screws used to mount the optical assembly bracket to the top cover are longer than the others.

3. See [Figure 24](#).

Remove the Lens Flat Gasket .

4. Turn the top cover over and push the lens and gasket out of the pocket in the cover.



CAUTION

Cracked or broken glass is very sharp. Take necessary precautions to protect hands from being cut. Failure to follow this instruction can result in injury or equipment damage.

5. If lens is cracked, pitted, or damaged discard the lens and gasket and replace with new lens and gasket.

If just the gasket is damaged replace the gasket on the lens.

6. Reassembly in the opposite order as disassembled.

Torque the eight M6 hex head screws to 75 +/- 5 in-lbs.



Note

Be sure to use the two longer M6 Hex Cap screws to fasten the optical bracket to the top cover.

Step 1: Finger tighten the screws down against the Lens Support Plate. Torque the first screw and then torque the screw that is 180 degrees from the first screw. Repeat this process on each of the screws. Torque each screw to 75 +/- 5 In-lbs.

Figure 23: Figure 6-6 Remove LED Optical Bracket and Lens Support Plate

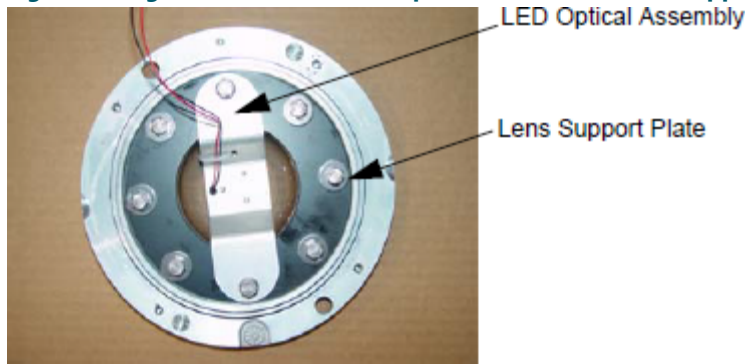

Figure 24: Figure 6-7 Remove Lens Flat Gasket

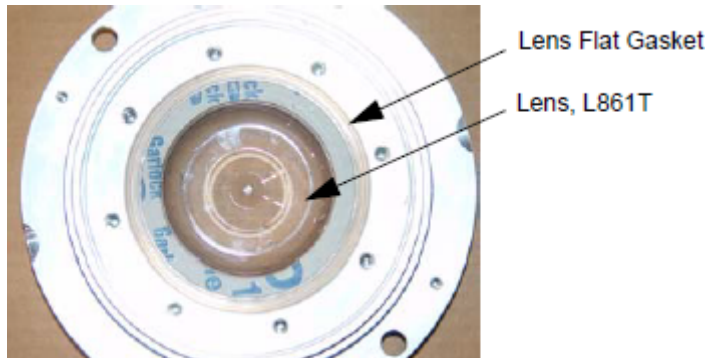
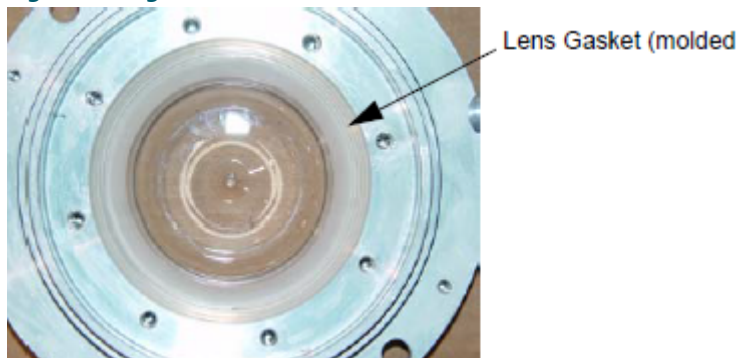

Figure 25: Figure 6-8 Remove Lens and Lens Gasket



7. Clean the lens recess in the cover thoroughly with any effective solvent.
8. Close the light fixture.
Refer to [Closing and Testing Light Assembly](#).

5.1.7 Closing and Testing Light Assembly

To close and test the light assembly, perform the following procedure:



CAUTION

Misalignment of the index pin in the inner cover flange and its mating hole in the underside of the top cover will prevent components from being assembled correctly. Damage may also occur to the top cover and inner cover. Failure to follow this instruction can result in equipment damage.

1. See [Figure 26](#).
Turn the cover over and find the arrow cast into the top of the cover. This arrow indicates the location of the index pin hole that is machined into the underside area of the top cover.
2. See [Figure 27](#).

Find index pin molded into the flange of the inner cover. The index pin needs to align with its mating hole found on the underside of the top cover.

Figure 26: Index Pin Hole Arrow

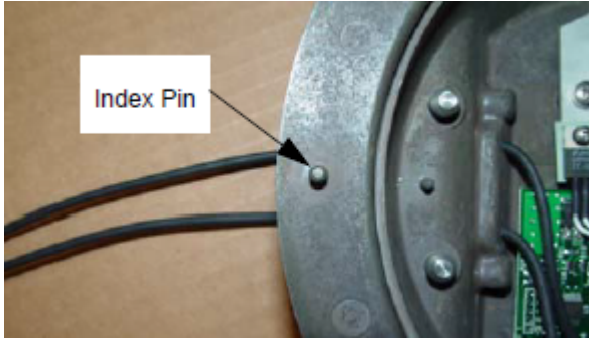
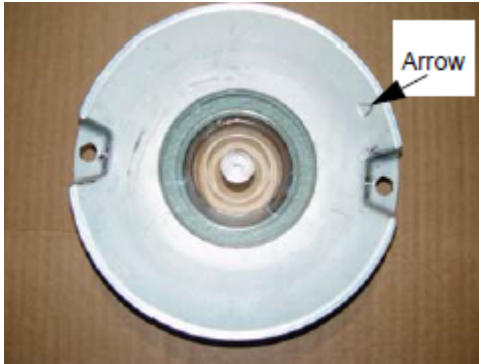

Figure 27: Index Pin of Inner Cover Flange



3. Put the top cover over the inner cover and align the index pin on the inner cover flange with the index arrow on the top cover
4. Gently put the inner cover on top of the cover ([Figure 26](#)), taking into account the index pin between both parts. Make sure that LED leads do not get damaged when the top cover is installed on the inner cover. See also [Figure 32](#).
5. Press the inner cover on the cover and secure with new Phillips pan head screws with washers. Refer to [Figure 22](#).
6. Check the electrical insulation from two-pole plug to frame by means of a 500 V insulation tester. Apply an AC current not exceeding 6.6 A on the two-pole plug and observe normal operation of the LED.



CAUTION

The electronic circuit is designed to be fed from a regulated AC constant current generator only, for example, a constant current regulator. Do not use a voltage generator as this might damage the electronic components or fail to energize the light.

Failure to follow this instruction can result in equipment damage.

-
7. Check the waterproof ability of the fitting by applying an overpressure of 1.4 bar (140kPa) via the pressure release hole. While pressure is applied, immerse the light fixture for one minute in water and look carefully for any air bubbles emanating from the light fixture. Dry the fixture and remove it from the air hose.
 8. Install and tighten the pressure release screw.

5.1.8 Testing for Leaks

To test for leaks, perform the following procedure:

1. See [Figure 28](#).

Remove pressure relief screw.

2. See [Figure 29](#).

Screw pressure test fitting into the pressure relief port (the opening created when the pressure relief screw is removed).
Screw fitting hand-tight.

Figure 28: Pressure Relief Screw



Figure 29: Pressure Test Fitting Assembly

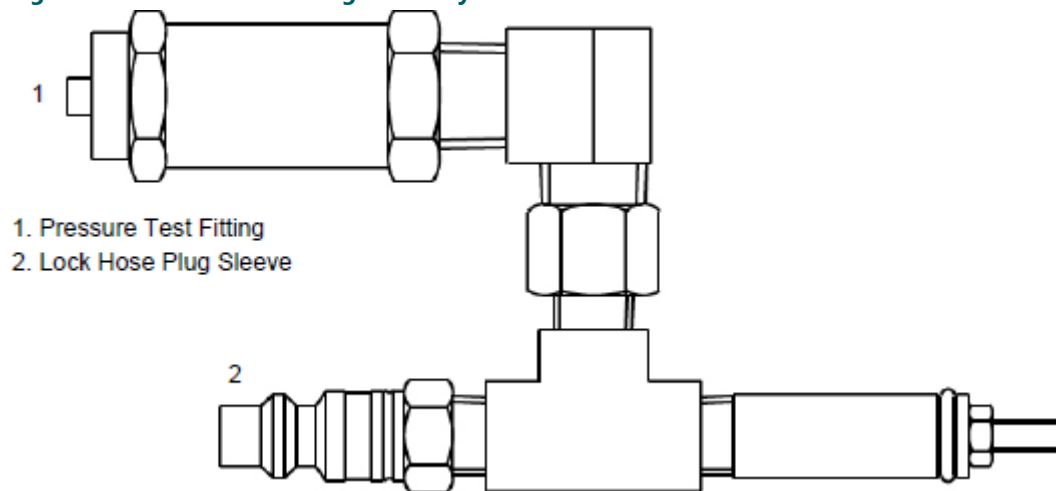

3. Attach the shop airline to the lock hose plug sleeve (2).

4. Pressurize to 20 psi.

5. Submerge the pressure test fitting in a water tank.

Check for air bubbles. Air bubbles indicate a leak.

6. Locate the leak source, depressurize, replace the seal that is leaking, reassemble, and retest by following steps 4 and 5.

If leak is fixed, depressurize and reinstall the pressure release screw (1).

Go to [Installation](#) to finish.

6.0 ITEL Parts

Ordering Code

LED Color

- 8 = Yellow
- 9 = White
- A = Green
- B = Red
- C = L-852T(L) Aviation Blue¹

Mounting

- 1 = 12-inch fixture for standard L-868B light base¹
- 2 = 12-inch fixture for standard L-867B light base¹
- 3 = 8-inch fixture for ICAO light base
- 4 = 8-inch fixture with L-868B adapter ring
- 6 = 8-inch fixture with L-867B adapter ring, bottom mounted
- 7 = 8-inch fixture with L868B snow plow ring
- 8 = 8-inch fixture with 11-inch adapter ring

Power

- 1 = 60 Hz¹
- 2 = 50 Hz²

Arctic Option

- 0 = Without arctic option
- 1 = With arctic option

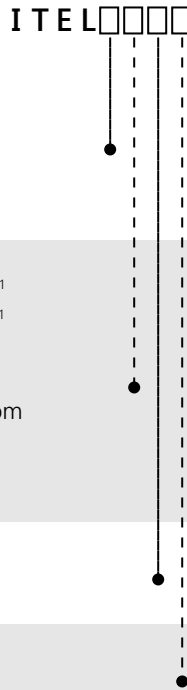

Notes:

1. ETL Certified
2. Any 50 Hz option carries the CE Mark

6.1 ITEL Spare Parts

Table 6: Spare Parts

Description	Part No.
Cable clamp, inner cover	4071.50.090
Cable clamp, with monitoring	62A2169
Cord set, L-823	44A7387-10
Cord set, 4-pin, monitoring	73A0139
Grommet, cord set (2)	63A1014
LED light engine, L-852T(L), blue, w/out arctic kit ¹	44A7177-10
LED light engine, L-852T(L), blue, with arctic kit ¹	44A7177-11
LED PCB, blue, 50 Hz, with monitoring	44A7197-50-1
LED PCB, blue, 50 Hz, without monitoring	44A7197-50-0
LED PCB, blue, 60 Hz, with monitoring	44A7197-60-1
LED PCB, blue, 60 Hz, without monitoring	44A7197-60-0
Lens	63A1071

Table 6: Spare Parts (Continued)

Description	Part No.
Lens, support plate	4071.76.020
Lens gasket, flat protection	61A0539
Lens gasket, molded	4071.76.041
O-ring, inner cover seal	63A1285
O-ring, pressure release screw	63B0267-011
Pressure release screw	60A2602
Anti-rotation Pin	4071.50.120
ITEL LED PS PCB ASSY 60HZ W/MONITORING	44A6596
ITEL LED PS PCB ASSY 60HZ W/O MONITORING	44A6596-2
PCB ASSY, APS ITEL PWR SUPPLY	44A6908-3

Notes

¹ When replacing blue LED light engines in fixtures shipped before June 2012, please consult the manual or call the ADB SAFEGATE Sales Department.

6.2 Illustrated Parts List

Figure 30: ITEL Pan Assembly

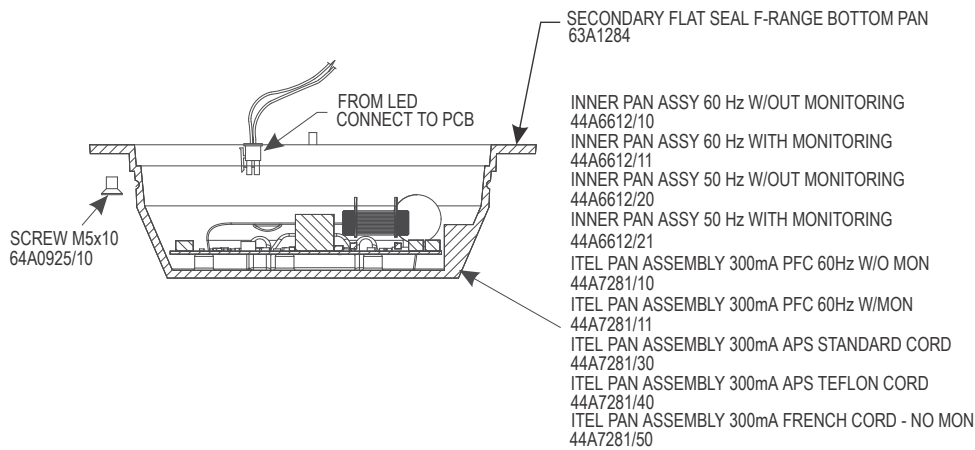

Figure 31: ITEL Pan Assembly with molded cord set

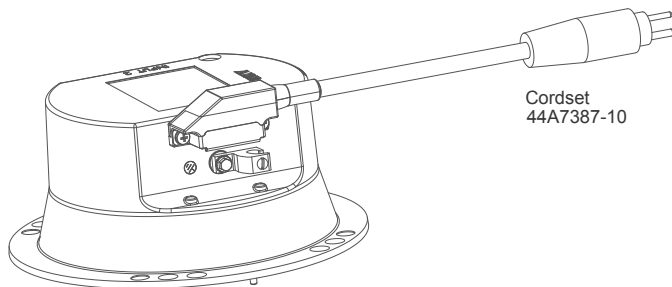

Figure 32: Top Cover without heater

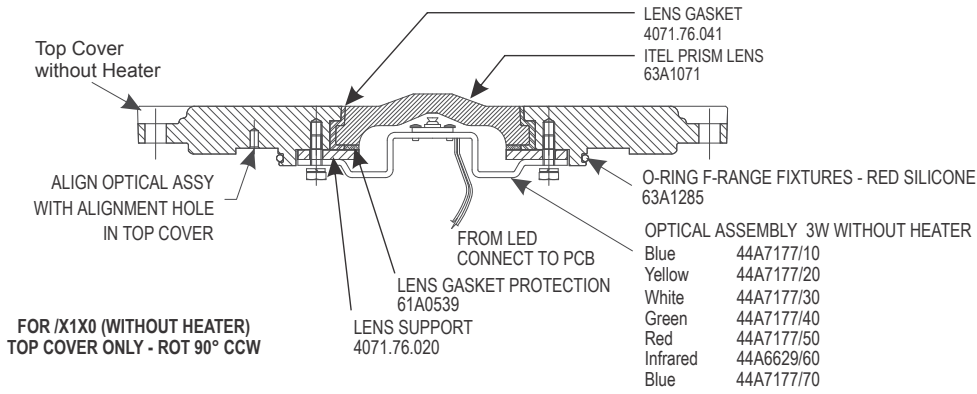

Figure 33: Top Cover with heater

FOR /X1X1 (WITH CURRENT HEATER)
TOP COVER ONLY - ROT 90° CCW

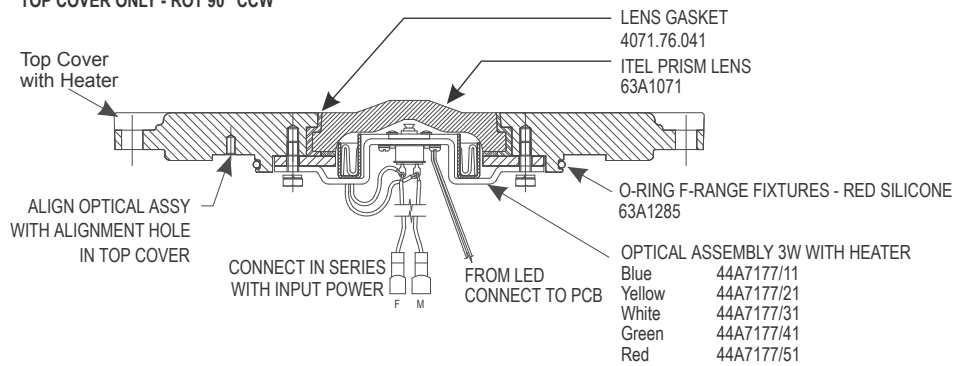

Figure 34: Snow Plow Ring

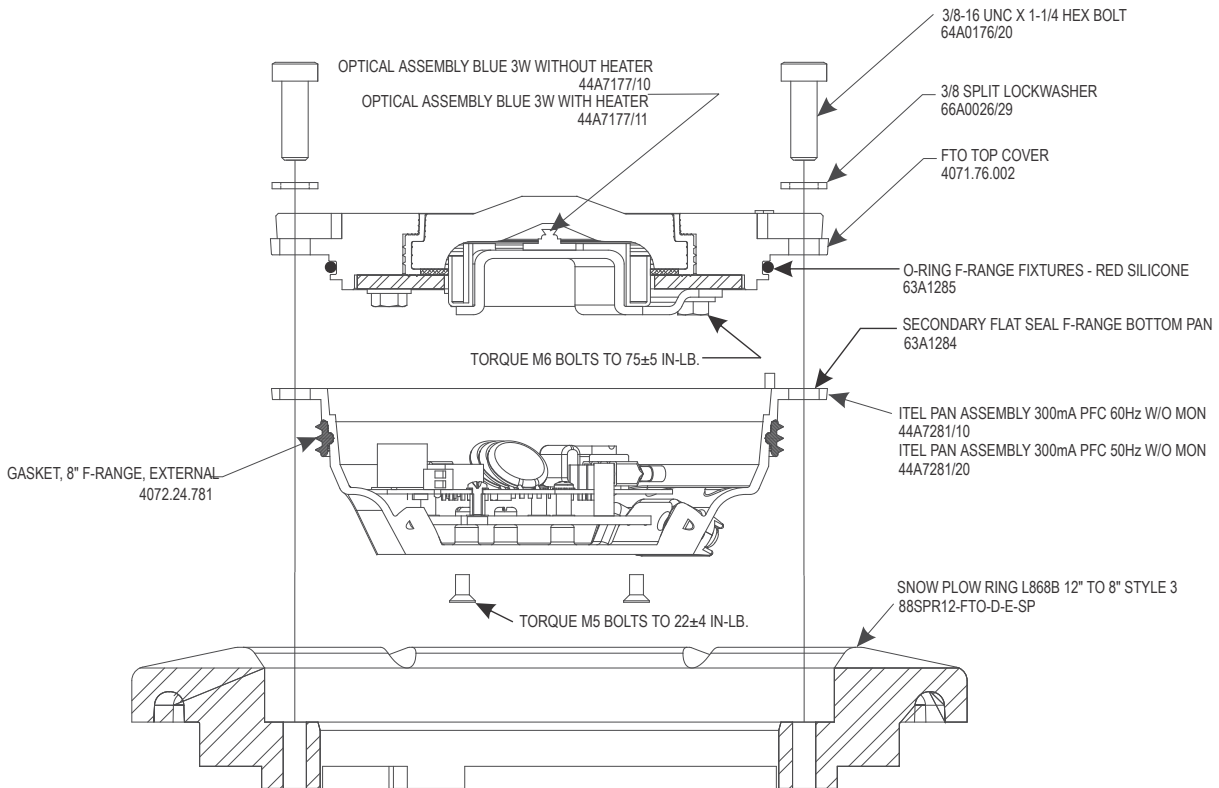

Figure 35: Adapter Ring 10.65"

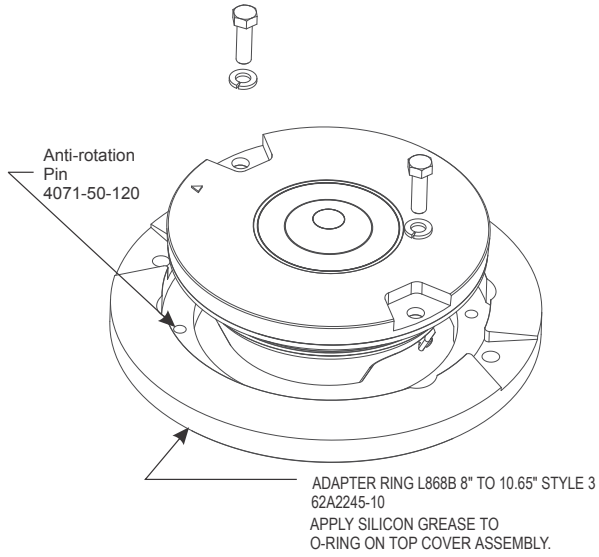
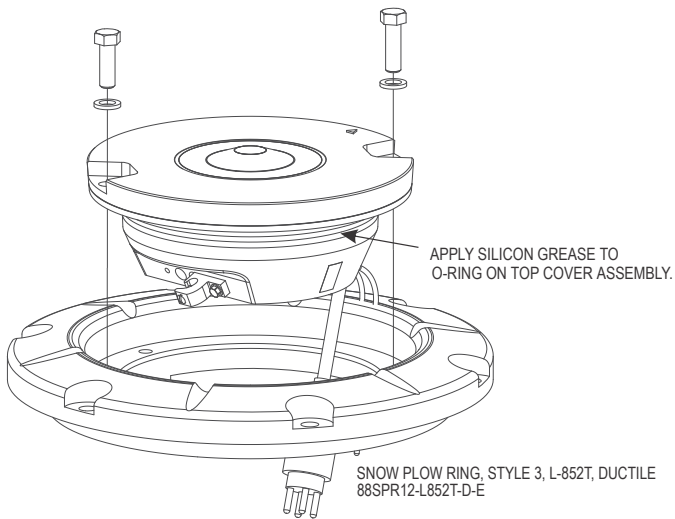

Figure 36: Adapter Ring 12"



Appendix A: SUPPORT

Our experienced engineers are available for support and service at all times, 24 hour/7 days a week. They are part of a dynamic organization making sure the entire ADB SAFEGATE is committed to minimal disturbance for airport operations.

ADB SAFEGATE Support

Technical Support – Global

Customers in Europe, the Middle East, Africa or Asia Pacific are more than welcome to our portal for technical support. Trained in all areas of system issues, troubleshooting, quality control and technical assistance, our highly experienced Technical support specialists are available 24 hours a day, seven days a week to provide assistance over the phone. In the Americas, we also offer live technical support.

Live Technical Support – Americas

If at any time you have a question or concern about your product, contact ADB SAFEGATE's US-based technical support specialists, available 24 hours a day, seven days a week, to assist you via phone.

ADB SAFEGATE Americas Technical Service & Support (US & Canada) :+1-800-545-4157

ADB SAFEGATE Americas Technical Service & Support (Canada): +1-905-631-1597

ADB SAFEGATE Americas Technical Service & Support (International): +1-614-861-1304

We can also be reached via email during regular business hours:

Airfield and Gate: techservice.us@adbsafegate.com

Gate: gateservice.us@adbsafegate.com

We look forward to working with you!

Before You Call

When you have an airfield lighting or system control system problem, prior to calling, please ensure the following:

- Review the product's manual and troubleshooting guide.
- Be located with the product ready to troubleshoot.
- Have all necessary information available: airport code/company name, customer id number, contact phone number/email address, product/part number.
- Have a *True RMS* meter available and any other necessary tools.

When calling about an issue with Safedock A-VDGS, we can serve you better if you collect the following information before you call:

- Relevant information regarding the issue you are calling about, such as gate number, flight number, aircraft type and time of the event.
- What, if any, actions have been taken to resolve the issue prior to the call.
- If available, provide a CCTV recording of the incident to aid in aligning the information from the Safedock log file.

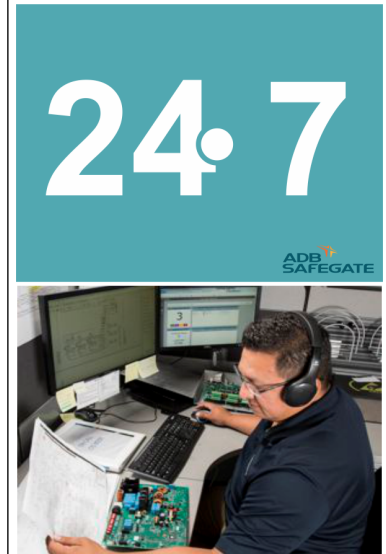

Note

For more information, see www.adbsafegate.com, contact ADB SAFEGATE Support via email at support@adbsafegate.com or

Europe: +32 2 722 17 11

Americas: +1 614 861 1304. Press 3 for technical service or press 4 for sales support.

China: +86 (10) 8476 0106

Middle East and Africa: +971 4 452 7575

A.1 ADB SAFEGATE Website

The ADB SAFEGATE website, www.adbsafegate.com, offers information regarding our airport solutions, products, company, news, links, downloads, references, contacts and more.

A.2 Recycling

A.2.1 Local Authority Recycling

The disposal of ADB SAFEGATE products is to be made at an applicable collection point for the recycling of electrical and electronic equipment. The correct disposal of equipment prevents any potential negative consequences for the environment and human health, which could otherwise be caused by inappropriate waste handling. The recycling of materials helps to conserve natural resources. For more detailed information about recycling of products, contact your local authority city office.

A.2.2 ADB SAFEGATE Recycling

ADB SAFEGATE is fully committed to environmentally-conscious manufacturing with strict monitoring of our own processes as well as supplier components and sub-contractor operations. ADB SAFEGATE offers a recycling program for our products to all customers worldwide, whether or not the products were sold within the EU.

ADB SAFEGATE products and/or specific electrical and electronic component parts which are fully removed/separated from any customer equipment and returned will be accepted for our recycling program.

All items returned must be clearly labeled as follows:

- For *ROHS/WEEE* Recycling
- Sender contact information (Name, Business Address, Phone number).
- Main Unit Serial Number.

ADB SAFEGATE will continue to monitor and update according for any future requirements for *EU directives* as and when *EU member states* implement new *regulations* and or *amendments*. It is our aim to maintain our *compliance plan* and assist our customers.

Company Addresses

ADB SAFEGATE, Belgium	ADB SAFEGATE BV Leuvensesteenweg 585, B-1930 Zaventem Belgium
Contact: Tel.: +32 2 722 17 11 Fax: +32 2 722 17 64	Email: marketing@adbsafegate.com Internet: www.adbsafegate.com
ADB SAFEGATE, Americas	ADB SAFEGATE Americas LLC 700 science Blvd, Columbus OH 43230, USA
Contact: Tel.: +1 (614) 861 1304 Fax: +1 (614) 864 2069	Email: sales.us@adbsafegate.com Internet: www.adbsafegate.com
ADB SAFEGATE, Sweden	ADB SAFEGATE Sweden AB Djurhagegatan 19 SE-213 76 Malmö Sweden
Contact: Tel.: +46 (0)40 699 17 00 Fax: +46 (0)40 699 17 30	Email: marketing@adbsafegate.com Internet: www.adbsafegate.com
ADB SAFEGATE, China	ADB SAFEGATE Airfield Technologies Ltd. China Unit 603, D Block, CAMIC International Convention Center, No 3, Hua Jia Di East road, ChaoYang district, Beijing 100102 P.R. China
Contact: Tel.: +86 (10) 8476 0106 Fax: +86 (10) 8476 0090	Email: china@safegate.com Internet: www.adbsafegate.com
ADB SAFEGATE, Germany	ADB SAFEGATE Germany GmbH Konrad-Zuse-Ring 6, D-68163 Mannheim Germany
Contact: Tel.: +49 (621) 87 55 76-0 Fax: +49 (621) 87 55 76-55	Email: marketing@adbsafegate.com Internet: www.adbsafegate.com



Powering Your Airport Performance from Approach to Departure

adbsafegate.com

Copyright © ADB SAFEGATE, all rights reserved

