



Single-Channel PAPI, Precision Approach Path Indicator
Type L-880 & L-881, Style A (Voltage-Powered) & Style B
(Current-Powered)

User Manual

96A0379, Rev. U, 2022/10/21

**ADB
SAFEGATE**

A.0 Disclaimer / Standard Warranty

CE certification

The equipment listed as CE certified means that the product complies with the essential requirements concerning safety and hygiene. The European directives that have been taken into consideration in the design are available on written request to ADB SAFEGATE.

ETL certification

The equipment listed as ETL certified means that the product complies with the essential requirements concerning safety and FAA Airfield regulations. The FAA directives that have been taken into consideration in the design are available on written request to ADB SAFEGATE.

All Products Guarantee

ADB SAFEGATE will correct by repair or replacement per the applicable guarantee above, at its option, equipment or parts which fail because of mechanical, electrical or physical defects, provided that the goods have been properly handled and stored prior to installation, properly installed and properly operated after installation, and provided further that Buyer gives ADB SAFEGATE written notice of such defects after delivery of the goods to Buyer. Refer to the Safety section for more information on Material Handling Precautions and Storage precautions that must be followed.

ADB SAFEGATE reserves the right to examine goods upon which a claim is made. Said goods must be presented in the same condition as when the defect therein was discovered. ADB SAFEGATE further reserves the right to require the return of such goods to establish any claim.

ADB SAFEGATE's obligation under this guarantee is limited to making repair or replacement within a reasonable time after receipt of such written notice and does not include any other costs such as the cost of removal of defective part, installation of repaired product, labor or consequential damages of any kind, the exclusive remedy being to require such new parts to be furnished.

ADB SAFEGATE's liability under no circumstances will exceed the contract price of goods claimed to be defective. Any returns under this guarantee are to be on a transportation charges prepaid basis. For products not manufactured by, but sold by ADB SAFEGATE, warranty is limited to that extended by the original manufacturer. This is ADB SAFEGATE's sole guarantee and warranty with respect to the goods; there are no express warranties or warranties of fitness for any particular purpose or any implied warranties of fitness for any particular purpose or any implied warranties other than those made expressly herein. All such warranties being expressly disclaimed.

Standard Products Guarantee

Products manufactured by ADB SAFEGATE are guaranteed against mechanical, electrical, and physical defects (excluding lamps) which may occur during proper and normal use for a period of two years from the date of ex-works delivery, and are guaranteed to be merchantable and fit for the ordinary purposes for which such products are made.



Note

See your applicable sales agreement for a complete warranty description.

Replaced or repaired equipment under warranty falls into the warranty of the original delivery. No new warranty period is started for these replaced or repaired products.

FAA Certified products manufactured by ADB SAFEGATE

ADB SAFEGATE L858 Airfield Guidance Signs are warranted against mechanical and physical defects in design or manufacture for a period of 2 years from date of installation, per FAA AC 150/5345-44 (applicable edition).

ADB SAFEGATE LED products (with the exception of obstruction lighting) are warranted against electrical defects in design or manufacture of the LED or LED specific circuitry for a period of 4 years from date of installation, per FAA EB67 (applicable edition). These FAA certified constant current (series) powered LED products must be installed, interfaced and powered with and through products certified under the FAA Airfield Lighting Equipment Program (ALECP) to be included in this 4 (four) year warranty. This includes, but is not limited to, interface with products such as Base Cans, Isolation Transformers, Connectors, Wiring, and Constant Current Regulators.



Note

See your sales order contract for a complete warranty description.

Replaced or repaired equipment under warranty falls into the warranty of the original delivery. No new warranty period is started for these replaced or repaired products.

Liability



WARNING

Use of the equipment in ways other than described in the catalog leaflet and the manual may result in personal injury, death, or property and equipment damage. Use this equipment only as described in the manual.

ADB SAFEGATE cannot be held responsible for injuries or damages resulting from non-standard, unintended uses of its equipment. The equipment is designed and intended only for the purpose described in the manual. Uses not described in the manual are considered unintended uses and may result in serious personal injury, death or property damage.

Unintended uses, includes the following actions:

- Making changes to equipment that have not been recommended or described in this manual or using parts that are not genuine ADB SAFEGATE replacement parts or accessories.
- Failing to make sure that auxiliary equipment complies with approval agency requirements, local codes, and all applicable safety standards if not in contradiction with the general rules.
- Using materials or auxiliary equipment that are inappropriate or incompatible with your ADB SAFEGATE equipment.
- Allowing unskilled personnel to perform any task on or with the equipment.

© ADB SAFEGATE SWEDEN AB

This manual or parts thereof may not be reproduced, stored in a retrieval system, or transmitted, in any form or by any means, electronic, mechanical, photocopying, recording, nor otherwise, without ADB SAFEGATE SWEDEN AB's prior written consent.

This manual could contain technical inaccuracies or typographical errors. ADB SAFEGATE SWEDEN AB reserves the right to revise this manual from time to time in the contents thereof without obligation of ADB SAFEGATE SWEDEN AB to notify any person of such revision or change. Details and values given in this manual are average values and have been compiled with care. They are not binding, however, and ADB SAFEGATE SWEDEN AB disclaims any liability for damages or detriments suffered as a result of reliance on the information given herein or the use of products, processes or equipment to which this manual refers. No warranty is made that the use of the information or of the products, processes or equipment to which this manual refers will not infringe any third party's patents or rights. The information given does not release the buyer from making their own experiments and tests.

© ADB SAFEGATE BV

This manual or parts thereof may not be reproduced, stored in a retrieval system, or transmitted, in any form or by any means, electronic, mechanical, photocopying, recording, nor otherwise, without ADB SAFEGATE BV's prior written consent.

This manual could contain technical inaccuracies or typographical errors. ADB SAFEGATE BV reserves the right to revise this manual from time to time in the contents thereof without obligation of ADB SAFEGATE BV to notify any person of such revision or change. Details and values given in this manual are average values and have been compiled with care. They are not binding, however, and ADB SAFEGATE BV disclaims any liability for damages or detriments suffered as a result of reliance on the information given herein or the use of products, processes or equipment to which this manual refers. No warranty is made that the use of the information or of the products, processes or equipment to which this manual refers will not infringe any third party's patents or rights. The information given does not release the buyer from making their own experiments and tests.

TABLE OF CONTENTS

1.0 Safety	1
1.1 Safety Messages	1
1.1.1 Introduction to Safety	2
1.1.2 Intended Use	2
1.1.3 Material Handling Precautions: Storage	3
1.1.4 Operation Safety	3
1.1.5 Maintenance Safety	3
1.1.6 Material Handling Precautions, ESD	4
2.0 Single Channel PAPI, Precision Approach Path Indicator	5
2.1 About this manual	5
3.0 Single Channel PAPI Overview	7
3.1 Precision Approach Path Indicator	7
3.2 Signal Display	8
3.2.1 Type L-880 PAPI System	8
3.2.2 Type L-881 PAPI System	8
3.3 PAPI Light Unit	9
3.4 Operation Overview - Style A	10
3.4.1 Power Control Unit (PCU)	10
3.4.2 Local/Remote Operation	11
3.4.3 Daytime Operation	12
3.4.4 Nighttime Operation	12
3.4.5 Output to Light Units	12
3.4.6 Optional Interlock Relay	12
3.5 Operation Overview - Style B System	12
3.5.1 Style B Power	12
3.6 Operation Overview - Style A and Style B Light Unit	13
3.6.1 Single Channel PAPI Control Board Overview	13
3.6.2 Single-Channel PAPI Inclinator Overview	14
4.0 Siting the PAPI System	15
4.1 Siting Considerations	15
4.1.1 Distance of the PAPI Light Units from the Runway Edge	15
4.1.2 Lateral Spacing of the PAPI Light Units	15
4.2 Siting a PAPI with an ILS Glideslope	15
4.3 Siting PAPI on Runways Without ILS	16
4.3.1 Threshold Crossing Height (TCH)	17
4.3.2 Glideslope Angle	17
4.3.3 Distance of PAPI from Threshold	17
4.3.4 Obstacle Clearance Surface	17
4.3.5 Reduction of Beam Coverage for Obstacle Avoidance	18
4.4 Siting Tolerances	19
4.4.1 Azimuth Aiming	19
4.4.2 Mounting Height Tolerance	19
4.4.3 PAPI Tolerance Along Line Perpendicular to Runway	19
4.4.4 Correction for Runway Longitudinal Gradient	20
4.5 Additional Siting Considerations	21
5.0 Installation	23
5.1 Safety Considerations	23
5.1.1 Installation	23
5.2 Inspect the Equipment	23
5.2.1 What's Included	23
5.2.2 Required Materials Supplied by Others	24
5.3 Installing the PCU Power Control Unit (Style A Only)	24
5.4 Installing the Light Units (Style A and B)	24

5.5 Attach the PAPI Light Unit Housing to the Legs	25
5.6 System External Wiring Connections	25
5.6.1 Style A Wiring Between Power Control Unit and the Light Unit	25
5.6.2 Connecting Wiring Between the PAPI Light Units Through Conduit	27
5.6.3 Style B Wiring Between Each Light Unit	28
5.7 Align the PAPI	29
5.7.1 Initial Setup	29
5.7.2 Adjusting the Azimuth Angle	30
5.7.3 Adjusting the Glide Angle	30
5.7.4 Saving the Glide Angle to Memory	30
6.0 Operation	35
6.1 Operation Safety Considerations	35
6.1.1 Normal Operation	35
6.1.2 Preparation for Heavy Snowfall	35
6.1.3 Criteria for System Deactivation	35
6.2 Understanding the LED Readout	36
6.2.1 Seven-Segment Display	36
6.2.2 Push Button Functions	37
6.3 Initial Startup Using Local Control (Style A)	37
6.4 Set Up and Test Remote Control Operation	39
6.5 Set Up and Test Optional Interlock Relay	39
6.6 Adjusting the Over Current Detection Level	40
6.7 Initial Startup of the Style B System	40
6.7.1 Check Light Unit Alignment	40
6.7.2 Verify Correct Input Current in Each Light Unit	40
6.8 Commissioning the PAPI System	41
7.0 Maintenance	43
7.1 Maintenance and Repair Safety Considerations	43
7.2 Maintenance Schedule	43
7.3 Standards and Tolerances	44
7.4 Maintenance Procedures	45
7.4.1 Replacing a Lamp	45
7.4.2 Replacing Objective Lenses	45
7.4.3 Replacing the Red Filter	45
7.4.4 Replacing an Inclinometer PCB Assembly	46
7.4.5 Checking Slope Angles of PAPI Unit	46
8.0 Field Installation of Adjustable PAPI Baffles	49
8.1 Introduction	49
8.1.1 References	49
8.1.2 Special Tools and Equipment Required	49
8.1.3 Items Included in PAPI Baffle Retrofit Kits	49
8.1.4 PAPI Baffle Retrofit Kit Ordering Code	50
8.1.5 Baffle Kit Parts List	50
8.2 Modification Procedure	51
9.0 Troubleshooting and Repair	57
9.1 Troubleshooting Tips	57
9.2 Detailed Troubleshooting and Repair Procedures	58
9.2.1 Troubleshooting and Repairing the Power Control Unit (Style A Only)	58
9.2.2 CCT-Control PCB1 Replacement in Power Control Unit (PCU)	59
9.3 Troubleshooting and Repairing the Light Unit	60
9.3.1 Light Unit Control Board Replacement	61
9.3.2 Light Unit Inclinometer Board Replacement	62
9.3.3 Red Filter Replacement	62
9.4 Schematics	64
9.4.1 Drawings	64
10.0 Single Channel PAPI Parts	73
10.1 Spare Parts	80

A.0 SUPPORT	83
A.1 ADB SAFEGATE Website	83
A.2 Recycling	83
A.2.1 Local Authority Recycling	83
A.2.2 ADB SAFEGATE Recycling	84

List of Figures

Figure 1: Fig. 1 Style A L-881 (2 Box) PAPI System	0
Figure 2: Fig. 2 Power Control Unit Installation (Style A Only)	0
Figure 3: Fig. 3 Light Unit Installation	0
Figure 4: Fig. 4 Light Unit Dimensions	0
Figure 5: Signal Display - L-880 and L-881 Systems	9
Figure 6: PAPI Light Unit Lamps (3) Red filter Control PCB (with digital readout)	9
Figure 7: Power Control Unit (PCU) Components	11
Figure 8: PAPI Obstacle Clearance Surface	16
Figure 9: Obstacle Clearance Surface	18
Figure 10: Light Unit Mounting Height	19
Figure 11: Correction for Runway Longitudinal Gradient	20
Figure 12: Example PAPI Installation	21
Figure 13: L-880/L-881, Style A, Power Control Unit (PCU) External Connections - 117A0047	26
Figure 14: L-880/L-881, Style A, Power Control Unit (PCU) Frangible Connection - 117A0047	27
Figure 15: L-880/L-881 PAPI Light Unit Power Cable Frangible Connection	28
Figure 16: Light Unit Control Board	31
Figure 17: Control Board Pushbuttons	32
Figure 18: CCT Control Board	38
Figure 19: Checking Slope Angles	46
Figure 20: Single Channel PAPI Box Assembly	51
Figure 21: Baffle Located on Right Side of Enclosure Filter Bracket for Obstacle Located on Left Side	52
Figure 22: Baffle Located on Left Side of Enclosure Filter Bracket for Obstacle Located on the Right Side	53
Figure 23: PAPI Signal Viewing Zone	53
Figure 24: Squaring Top Edge of Baffle Mounting Plate	54
Figure 25: Squaring Baffle Plate with Top Edge of Baffle Mounting Plate	54
Figure 26: Light Unit Control Board Indicators and Test Points	61
Figure 27: External Wiring, Single Channel PAPI Style A, L-881 (2 Box) System	64
Figure 28: External Wiring, Single Channel PAPI Style A, L-880 (4 Box) System	65
Figure 29: External Wiring, Single Channel PAPI Style B, L-881 (2 Box) System	66
Figure 30: External Wiring, Single Channel PAPI Style B, L-880 (4 Box) System	67
Figure 31: Power Control Unit (PCU) Wiring Schematic, Style A, 43A3292	68
Figure 32: TB1 External Connections	69
Figure 33: Single Channel PAPI Light Unit Connection Diagram, 43A3282	70
Figure 34: Single Channel PAPI Installation, 117A0047	71
Figure 35: Installation Parts - 117A0039	74
Figure 36: Single Channel PAPI Light Unit - 44A6853	75

Figure 37: Single Channel PAPI Light Unit - 44A6853 (Continued)	76
Figure 38: Control Board Assembly 44A7122 (Canada: 44A7122/1)	77
Figure 39: Power Control Unit (PCU) Assembly, Style A, 44A6752/XXX	78
Figure 40: Power Control Unit Panel, Style A, 44A6703	80

List of Tables

Table 1: T3 Secondary Voltages	10
Table 2: Threshold Crossing Height	16
Table 3: Components Supplied by ADB	23
Table 4: Aiming Angles for L-880 PAPI Light Units	31
Table 5: Aiming Angles for L-881 PAPI Units	31
Table 6: Conversion from Decimal Degrees to Minutes	32
Table 7: Output Current	38
Table 8: Single-Channel PAPI Maintenance	43
Table 9: Precision Approach Path Indicator (PAPI) Standards and Tolerances	44
Table 10: References	49
Table 11: Required Equipment Not Supplied	49
Table 12: Baffle Kit 94A0570-XXX, Parts per Unit	50
Table 13: General PAPI System Troubleshooting Guide	57
Table 14: Style A Primary Panel Protection Devices	59
Table 15: CCT-Control PCB1 LED Indications	59
Table 16: Light Unit Control Board LED Troubleshooting Guide	60
Table 17: Single Channel PAPI Light Unit Parts	74
Table 18: Single Channel PAPI Light Unit Parts	76
Table 19: Control Board Parts	77
Table 20: Power Control Unit Parts	78
Table 21: Light Unit Spare Parts	81
Table 22: Power Control Unit Spare Parts	81

1.0 Safety

Introduction to Safety







This section contains general safety instructions for installing and using ADB SAFEGATE equipment. Some safety instructions may not apply to the equipment in this manual. Task- and equipment-specific warnings are included in other sections of this manual where appropriate.

1.1 Safety Messages

HAZARD Icons used in the manual

For all HAZARD symbols in use, see the Safety section. All symbols must comply with ISO and ANSI standards.

Carefully read and observe all safety instructions in this manual, which alert you to safety hazards and conditions that may result in personal injury, death or property and equipment damage and are accompanied by the symbol shown below.

	<p>WARNING Failure to observe a warning may result in personal injury, death or equipment damage.</p>
	<p>DANGER - Risk of electrical shock or ARC FLASH Disconnect equipment from line voltage. Failure to observe this warning may result in personal injury, death, or equipment damage. ARC Flash may cause blindness, severe burns or death.</p>
	<p>WARNING - Wear personal protective equipment Failure to observe may result in serious injury.</p>
	<p>WARNING - Do not touch Failure to observe this warning may result in personal injury, death, or equipment damage.</p>
	<p>CAUTION Failure to observe a caution may result in equipment damage.</p>
	<p>ELECTROSTATIC SENSITIVE DEVICES This equipment may contain electrostatic devices.</p>

Qualified Personnel

	<p>Important Information The term qualified personnel is defined here as individuals who thoroughly understand the equipment and its safe operation, maintenance and repair. Qualified personnel are physically capable of performing the required tasks, familiar with all relevant safety rules and regulations and have been trained to safely install, operate, maintain and repair the equipment. It is the responsibility of the company operating this equipment to ensure that its personnel meet these requirements. Always use required personal protective equipment (PPE) and follow safe electrical work practice.</p>
---	---

1.1.1 Introduction to Safety



CAUTION

Unsafe Equipment Use

This equipment may contain electrostatic devices, hazardous voltages and sharp edges on components

- Read installation instructions in their entirety before starting installation.
- Become familiar with the general safety instructions in this section of the manual before installing, operating, maintaining or repairing this equipment.
- Read and carefully follow the instructions throughout this manual for performing specific tasks and working with specific equipment.
- Make this manual available to personnel installing, operating, maintaining or repairing this equipment.
- Follow all applicable safety procedures required by your company, industry standards and government or other regulatory agencies.
- Install all electrical connections to local code.
- Use only electrical wire of sufficient gauge and insulation to handle the rated current demand. All wiring must meet local codes.
- Route electrical wiring along a protected path. Make sure they will not be damaged by moving equipment.
- Protect components from damage, wear, and harsh environment conditions.
- Allow ample room for maintenance, panel accessibility, and cover removal.
- Protect equipment with safety devices as specified by applicable safety regulations
- If safety devices must be removed for installation, install them immediately after the work is completed and check them for proper functioning prior to returning power to the circuit.

Failure to follow this instruction can result in serious injury or equipment damage

Additional Reference Materials



Important Information

- IEC - International Standards and Conformity Assessment for all electrical, electronic and related technologies.
- IEC 60364 - Electrical Installations in Buildings.
- FAA Advisory: AC 150/5340-26 (current edition), Maintenance of Airport Visual Aid Facilities.
- Maintenance personnel must refer to the maintenance procedure described in the ICAO Airport Services Manual, Part 9.
- ANSI/NFPA 79, Electrical Standards for Metalworking Machine Tools.
- National and local electrical codes and standards.

1.1.2 Intended Use



CAUTION

Use this equipment as intended by the manufacturer

This equipment is designed to perform a specific function, do not use this equipment for other purposes

- Using this equipment in ways other than described in this manual may result in personal injury, death or property and equipment damage. Use this equipment only as described in this manual.

Failure to follow this instruction can result in serious injury or equipment damage

1.1.3 Material Handling Precautions: Storage



CAUTION

Improper Storage

Store this equipment properly

- If equipment is to be stored prior to installation, it must be protected from the weather and kept free of condensation and dust.

Failure to follow this instruction can result in equipment damage

1.1.4 Operation Safety



CAUTION

Improper Operation

Do Not Operate this equipment other than as specified by the manufacturer

- Only qualified personnel, physically capable of operating the equipment and with no impairments in their judgment or reaction times, should operate this equipment.
- Read all system component manuals before operating this equipment. A thorough understanding of system components and their operation will help you operate the system safely and efficiently.
- Before starting this equipment, check all safety interlocks, fire-detection systems, and protective devices such as panels and covers. Make sure all devices are fully functional. Do not operate the system if these devices are not working properly. Do not deactivate or bypass automatic safety interlocks or locked-out electrical disconnects or pneumatic valves.
- Protect equipment with safety devices as specified by applicable safety regulations.
- If safety devices must be removed for installation, install them immediately after the work is completed and check them for proper functioning.
- Route electrical wiring along a protected path. Make sure they will not be damaged by moving equipment.
- Never operate equipment with a known malfunction.
- Do not attempt to operate or service electrical equipment if standing water is present.
- Use this equipment only in the environments for which it is rated. Do not operate this equipment in humid, flammable, or explosive environments unless it has been rated for safe operation in these environments.
- Never touch exposed electrical connections on equipment while the power is ON.

Failure to follow these instructions can result in equipment damage

1.1.5 Maintenance Safety



DANGER

Electric Shock Hazard

This equipment may contain electrostatic devices

- Do not operate a system that contains malfunctioning components. If a component malfunctions, turn the system OFF immediately.
- Disconnect and lock out electrical power.
- Allow only qualified personnel to make repairs. Repair or replace the malfunctioning component according to instructions provided in its manual.

Failure to follow these instructions can result in death or equipment damage

1.1.6 Material Handling Precautions, ESD



CAUTION

Electrostatic Sensitive Devices

This equipment may contain electrostatic devices

- Protect from electrostatic discharge.
- Electronic modules and components should be touched only when this is unavoidable e.g. soldering, replacement.
- Before touching any component of the cabinet you shall bring your body to the same potential as the cabinet by touching a conductive earthed part of the cabinet.
- Electronic modules or components must not be brought in contact with highly insulating materials such as plastic sheets, synthetic fiber clothing. They must be laid down on conductive surfaces.
- The tip of the soldering iron must be grounded.
- Electronic modules and components must be stored and transported in conductive packing.

Failure to follow this instruction can result in equipment damage

2.0 Single Channel PAPI, Precision Approach Path Indicator

Type L-880 & L-881, Style A (Voltage-Powered) & Style B (Current-Powered)



2.1 About this manual

The manual shows the information necessary to:

- Install
- Carry Out Maintenance
- Carry Out Troubleshooting on the Single-Channel PAPI.

How to work with the manual

1. Become familiar with the structure and content.
2. Carry out the actions completely and in the given sequence.

3.0 Single Channel PAPI Overview

This manual provides instructions for installation, operation and maintenance of the ADB SAFEGATE Single Channel Precision Approach Path Indicator (PAPI) system.

Single Channel PAPI systems provide visual approach path guidance to pilots of landing aircraft.



3.1 Precision Approach Path Indicator

Compliance with Standards

FAA:	L-880 / L-881 AC 150/5345-28 (Current Edition). ETL Certified.
ICAO:	Annex 14, Vol. 1, para. 5.3.5.23 to 5.3.5.45

Uses

The PAPI system uses a one light channel unit to provide the pilot precise visual information, enabling the approach procedure to be performed with the utmost accuracy and safety.

The Type L-880 PAPI system consists of four light units located at the side of the runway adjacent to the origin of the glide path. The nominal glide slope angle is midway between the angular settings of the central pair of the four units. If an aircraft is on the correct approach path, the pilot will see two red and two white light indicators. If the aircraft approach is too high, an increased number of white light indicators will be seen. If the approach is too low, the pilot will note an increased number of red light indicators.

The Type L-881 PAPI system is identical to the L-880, except only two light units (instead of four) are used. The nominal glide slope is midway between the angular settings of the two units, and when the pilot is on or close to the correct approach path, the unit nearest the runway will be seen as red and the other unit as white.

The Style A system is for use with an AC voltage input. The Style B system is for use on 6.6 A or 20 A series circuits. An electronic in-clinometer assembly, which is a mercury-free product, is provided on each PAPI unit to de-energize all light units if the optical pattern of any light unit is raised between 0.5° and 1.0° or lowered between 0.25° and 0.5° with respect to the setting angle of the light unit.

Shipping Information

Style A	
L-881 (2 Box)	48 × 40 × 28 in (122 × 102 × 71 cm) 188 lbs (85 kgs)
L-880 (4 Box)	48 × 40 × 40 in (122 × 102 × 102 cm) 278 lbs (126 kgs)

Style B	
L-881 (2 Box)	48 × 40 × 18 in (122 × 102 × 46 cm) 140 lbs (64 kgs)
L-880 (4 Box)	48 × 40 × 30 in (122 × 102 × 76 cm) 230 lbs (104 kgs)

Electrical Supply

Each Type A PAPI system is powered from a Control box. Each Type B PAPI light unit is powered with 6.6 A maximum via a 6.6A/6.6 A or 20 A/6.6 A 300 W isolation transformer. A field splice kit is supplied with each light unit to provide for external electrical connections between PAPI system components.

Style A ¹	
Input Voltage: 240 VAC, ±10%, 50/60 Hz L-880 (4-box) 3-lamps/light unit	1,700 VA max. ²
Input Voltage: 208/220/240 VAC, ±10%, 50/60 Hz L-881 (2-box) 3-lamps/light unit	1,612 VA max. ³
Style B ⁴	
Three Lamps – 6.6 A through one 300 W isolation transformer (each light unit)	
L-880 (4-Box) – Total CCR Load:	1,448 VA max.
L-881 (2-Box) – Total CCR Load:	724 VA max.

Notes

- ¹ As seen at input of Primary PAPI.
- ² Limit on distance from Primary to first light unit is 30 ft (9.1 m).
- ³ Limit on distance from Primary to first light unit is 150 ft (45.7 m).
- ⁴ VA calculation includes PAPI light units and isolation transformers.

3.2 Signal Display

3.2.1 Type L-880 PAPI System

The L-880 PAPI system consists of four identical Light Units installed in a line perpendicular to the runway centerline. The units are usually installed on the left side of the runway viewed from the approach end.

The units should be aimed so that pilots during a landing approach will see the signal format shown below left in [Figure 5](#) :

- If the aircraft is **too high above** the approach slope, **all four units are white** .
- If the aircraft is **slightly above** the approach slope, **three units are white** (farthest from the runway); the other is red.
- If the aircraft is close to or on the approach slope, two units are red and two are white.
- If the aircraft is **slightly below** the approach slope, **three units are red** (closest to the runway); the other is white.
- If the aircraft is **too far below** the approach slope, **all four units are red** .

3.2.2 Type L-881 PAPI System

The L-881 PAPI system consists of two identical Light Units installed in a line perpendicular to the runway centerline. The units are usually installed on the left side of the runway viewed from the approach end.

The units should be aimed so that pilots during a landing approach will see the signal format shown below right in [Figure 5](#) :

- If the aircraft is **too high above** the approach slope, **both units are white** .
- If the aircraft is close to or on the approach slope, one unit is red and one is white.
- If the aircraft is **too far below** the approach slope, **both units are red** .

Figure 5: Signal Display - L-880 and L-881 Systems

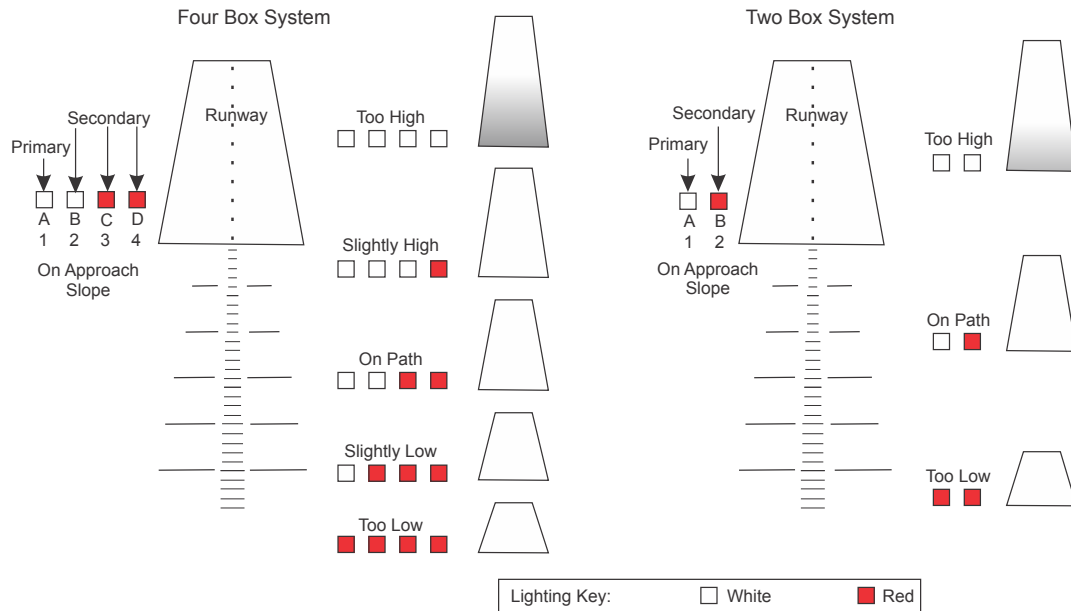

3.3 PAPI Light Unit

A single PAPI Light Unit contains three 6.6 A, 105W lamps, a red filter, two lenses, a lens shield, a Control PCB and an Inclinator PCB. The PAPI unit is mounted on two adjustable legs. See [Figure 10](#). Each component is discussed below.

Figure 6: PAPI Light Unit Lamps (3) Red filter Control PCB (with digital readout)

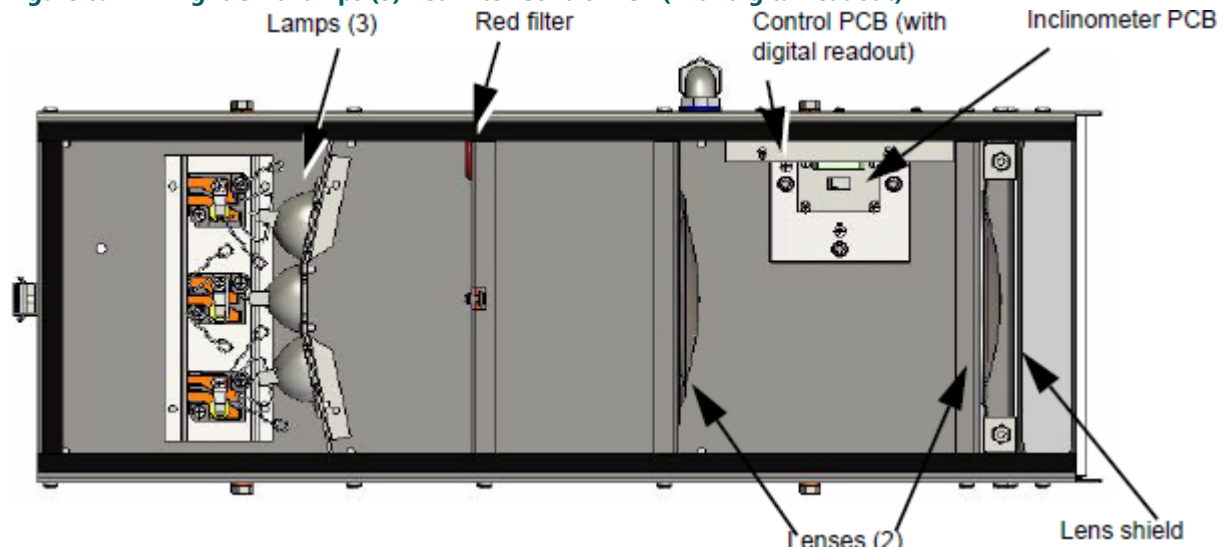

Lamps

Three 6.6A, 105W tungsten-halogen lamps are located in the rear of the unit, each lamp is individually secured in a fixed mounting bracket. Slip-on type electrical connections permit easy replacement of failed lamps.

Red Filter

The red filter is housed in a filter panel.



Note

The filter has a precision ground edge for sharp color transition. **DO NOT REMOVE THIS FILTER.** Improper mounting will adversely affect the performance of your PAPI light unit.

Lenses

Two high optical quality objective lenses are housed in two lens panels.

Lens Shield

The flat glass shield (protective glass) is designed to reduce reflections and protect the front lens against small particles such as sand, stone and debris.

Alignment System

A digital readout on the Control PCB eases setting the glide and azimuth of the PAPI units for proper function. Three threaded adjustment rods—two along the front edge and one in the rear—raise, lower and allow leveling of the Light Unit. The glide angle is shown on the digital readout—and can be read when looking through the front of the Light Unit when power is ON.

The horizontal (Azimuth) angle can be displayed via a push button on the circuit board.

Tilt Detection Electronics

The tilt measurement/control electronics, built into the Control PCB and Inclinator PCB, are designed to de-energize the lamps if the optical pattern is raised more than ½ degree or lowered more than ¼ degree from the proper setting angle or if the optical pattern is tilted horizontally in either direction more than 1.75 degrees.

If any Light Unit is moved from proper vertical or horizontal alignment, all PAPI Light Units will de-energize after about 25 seconds.



Note

For Canadian PAPIs, the tilt/de-energizing lamps function is not present.

3.4 Operation Overview - Style A

This section provides an overview of operation for the Style A Single-Channel PAPI system.

3.4.1 Power Control Unit (PCU)

See [Figure 7](#) and the drawing in [Schematics](#) section. Input voltage is supplied to the Power Control Unit (PCU) at TB1-1 and TB1-3. The Earth Ground connection may be input directly into the (PCU) with the incoming power wiring (and connected to the internal panel ground lug) or alternately, externally connected to the external ground lug on the enclosure. Note: No incoming power wiring is connected to TB1-2. Incoming voltage at TB1-1 and TB1-3 is fed through VR1 and VR2 for protection from lightning. Input voltage is then fed through circuit breaker CB1 and contactor K1. CB1 provides over-current protection. When CB1 is turned on, input voltage is fed to transformer T3 via protective fuses F1 and F2. Transformer T3 steps the incoming voltage (208VAC, 220VAC or 240VAC) down to various internal operating voltages as defined in [Table 1](#).

Table 1: T3 Secondary Voltages

Primary Control Unit Input Voltage (nominal)	208VAC	220VAC	240VAC
Terminal 5-6	15.6VAC	16.5VAC	18VAC
Terminal 7-6	15.6VAC	16.5VAC	18VAC
Terminal 8-10	104VAC	110VAC	120VAC
Terminal 13-14	104VAC	110VAC	120VAC

The 18Vac (if 240Vac is supplied on the Primary input) at T3 terminals 5-6 and 7-6 is input into the CCT Control Board at J3 pins 1, 2 and 3 and provides power for the CCT Control Board internal DC power supplies. The 120Vac at T3 terminals 8-10 is input into the CCT Control Board at J3 pins 4 and 6 to provide power for contactor K1. If a fault is not detected, 120VAC is output from the CCT Control Board at J3 pins 7 and 8 to energize contactor K1 via fuse F4. The 120Vac at T3 terminals 13-14 is output, via Fuse F3, for various remote and local control signals.

When contactor K1 is energized, input voltage is fed to inductor L1, and the dual SCR block. The CCT Control PCB1 turns the SCRs on (via the dual SCR gate drive signals at terminal block J4) and provides regulated current to the lamps at TB1-13 and TB1-14, similar to that provided by a Constant Current Regulator. VR4, VR5 and VR6 provide lightning protection at the output.

The CCT Control Board PCB1 de-energizes contactor K1 if either an open circuit or over-current is detected on the series circuit output at TB1-13 and 14.

Figure 7: Power Control Unit (PCU) Components

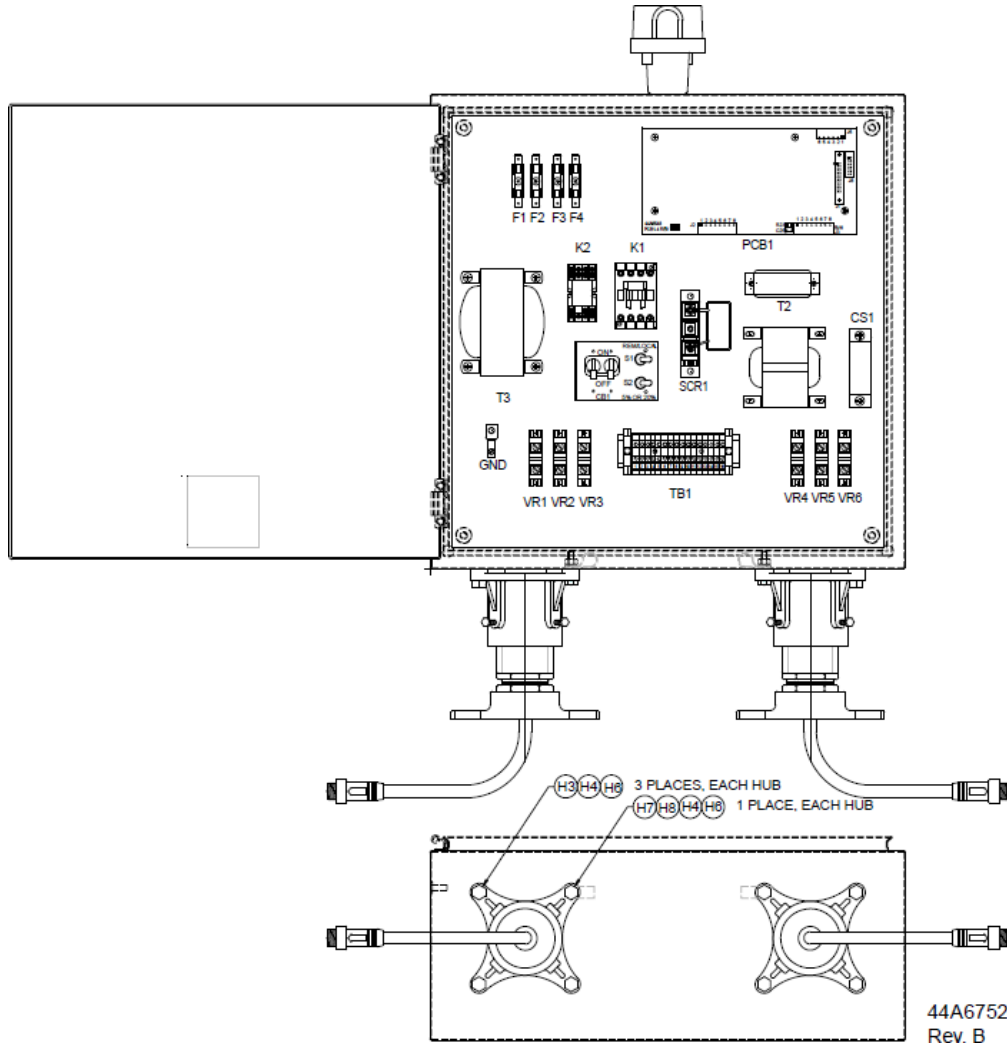

3.4.2 Local/Remote Operation

Toggle switch S1 enables local or remote mode operation. When set to LOCAL, the unit can be operated locally. When the switch S1 is set to remote (REM) and the remote wires are connected to TB1-7 and TB1-8, the PAPI system can be turned on or off from a remote location using a dry-switch contact closure across TB1-7 and TB1-8.

If S1 is in LOCAL, 120Vac is directly connected to the CCT-Control PCB J2-2 (the CC or ON input). The PAPI system then turns ON to either the 100% level (if Daytime) or to the 5% or 20% level (if Nighttime) as controlled by the photocell.

If S1 is in REMOTE and there is a Remote ON command via a contact closure across TB1-7 and 8 and it is Daytime, 120Vac (via TB1-8) is directly connected to the CCT-Control PCB J2-2 (the CC or ON input and J2-5 (the B3 or 5% command). This turns the PAPI ON to the 5% level. If switch S2 is set to 20%, 120Vac is also connected to J2-6 (the B4 or 20% command). This then turns the PAPI ON to the 20% level. If it is daytime, the photocell de-energizes K2. 120Vac is then connected, via the de-energized K2 pins 9-1, to the CCT-Control PCB J2-7 (the B5 or 100% input). The PAPI system then turns ON to the 100% level.

3.4.3 Daytime Operation

See the "Standard Wiring" section of the drawing in [Schematics](#) section. Photocell PC1 is powered with 120Vac via the white and black wires at TB1-4 and 5. When illumination on the photocell rises to 50-60 foot-candles, photocell PC1 is de-energized. A delay of 45-75 seconds is incorporated in the photocell circuit to prevent switching because of stray light or temporary shadows. Zero volts is then present on the red wire at TB1-6. This de-energizes relay K2. The normally closed contact at K2 pins 9-1 then provides 120VAC to J2-7 (the B5 or 100% input) on CCT-Control Board PCB1 and turns on the PAPI system to full intensity (6.6A to each lamp).

3.4.4 Nighttime Operation

When the illumination drops to 25 to 35 foot-candles, photocell PC1 energizes. 120VAC is then present on the red wire at TB1-6. This energizes relay K2 and removes 120VAC from J2-7 on CCT Control Board PCB1, shifting the PAPI system to low-intensity operation. A delay of 45-75 seconds is incorporated in the photocell circuit to prevent switching because of stray light or temporary shadows. If the photocell control circuitry fails, the system reverts to high intensity. Two night-intensity settings, 5% and 20% of full intensity, can be set by using toggle switch S2. This allows the user to select either of the two settings to accommodate local site conditions.

3.4.5 Output to Light Units

Power is provided to the lamps in the Light Units via TB1-13 and TB1-14 in the Power Control Unit. All lamps in each Light Unit are connected in series.

3.4.6 Optional Interlock Relay

See the "Alternate Wiring with Optional Interlock Relay (CS1)" section of the drawing in [Schematics](#) section. This option provides ON/OFF control through current sensing of the runway series circuit during nighttime operations when operated by remote control.

If S1 is in LOCAL, 120Vac is directly connected to the CCT-Control PCB J2-2 (the CC or ON input). The PAPI system then turns ON to either the 100% level (if Daytime) or to the 5% or 20% level (if Nighttime). Therefore, in this situation, the current sensing input has no effect on operation.

If S1 is in REMOTE and there is a Remote ON command via a contact closure across TB1-7 and 8 and it is Daytime, 120Vac is directly connected to the CCT-Control PCB J2-2 (the CC or ON input) and J2-5 (the B3 or 5% command) via the closed contacts at K2 pins 9-1 and 10-2. Therefore, in this situation, the current sensing input has no effect on operation.

If S1 is in REMOTE and there is a Remote ON command via a contact closure across TB1-7 and 8 and it is Nighttime, and the current in the series circuit is greater than 2.8A (as provided by an external isolation transformer connected to TB1-15 and TB1-16), contact CS1 is closed, which connects 120Vac to the CCT-Control PCB J2-2 (the CC or ON input) and J2-5 (the B3 or 5% command) and turns the PAPI ON to the 5% level. If switch S2 is set to 20%, 120Vac is also connected to J2-6 (the B4 or 20% command). This then turns the PAPI ON to the 20% level. If current in the series circuit is less than 2.8A, the CS1 contacts open, turning OFF the PAPI system.

3.5 Operation Overview - Style B System

This section provides an overview of operation for the Style B Single-Channel PAPI system.

3.5.1 Style B Power

The PAPI Style B is designed to operate from an L-828 constant current regulator (CCR) with a maximum output current of 6.6 A. A single 300 W isolation transformer is connected to each Light Unit. Current from the secondary of the isolation transformer supplies power to all three 105 W, 6.6 A lamps and both PC boards in each Light Unit. When used on a 20 A series lighting circuit, a 20A/6.6A isolation transformer must be used to step the current down to 6.6 A. The CCR controls the brightness of the PAPI system. The CCR may have three or five brightness steps.

Refer to one of the following wiring diagrams in: [Schematics](#) section.

3.6 Operation Overview - Style A and Style B Light Unit

The Light Units used in both the Style A and Style B systems are exactly the same. There are two boards in each Light Unit: the Control Board and the Inclinometer Board.

If any PAPI Light Unit is tilted, the tilt electronics are activated, de-energizing all Light Unit lamps after about 25 seconds. The PAPI system cannot be re-energized until all the PAPI units are in proper alignment.

3.6.1 Single Channel PAPI Control Board Overview

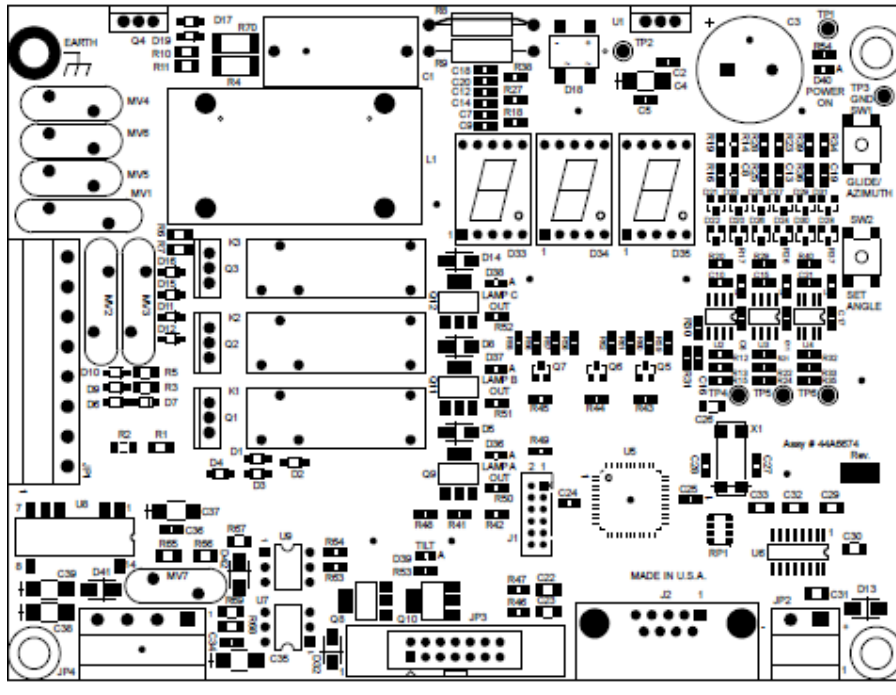

The Control Board has a micro-controller that controls all operations of the PAPI Light Unit as follows:

Lamps Out Feature

The micro-controller monitors the voltage across each lamp. If a lamp burns out, the micro-controller recognizes that an abnormal voltage is present and then energizes a relay that will short out the lamp. This allows the remaining lamp(s) to continue to operate. The associated red lamp-out LED will also be lit. After replacing the lamp, cycle power to the Light Unit to re-enable lamp-out monitoring for that lamp.

Tilt Measurement

The micro-controller reads the tilt sensor angle from the Inclinometer Board 20 times per second through a digital interface via the ribbon cable that connects the Control Board to the Inclinometer Board.

The angle is displayed on the three-digit display and compared to the set angle from the last time the **SET ANGLE** button was pushed. A tilt situation can occur in two situations. First, if the measured vertical (Glide) angle is either 0.25 degrees less than the desired glide angle or 0.50 degrees greater than the desired vertical (Glide) angle. Second, if the measured horizontal (Azimuth) angle is either less or greater than 1.75 degrees. The micro-controller will then turn all the lamps off within the Light Unit by energizing all three of the lamp relays and will also light the red **TILT** LED D39, the actual measured angle will be displayed. The red **LAMPS OUT** LEDs for all three lamps will also light.

External Tilt Signal

This is a parallel connected, two-wire signal that goes between all PAPI Light Units in the system. Normally, the Single-Channel PAPI Control Board will supply a voltage signal at connector JP4 as follows- pins 1 and 4: +8 to +12VDC; pins 3 and 4: Signal Common. If any PAPI Light Unit goes into a tilt situation, a relay on the Control Board will short the interconnecting Light Unit tilt signal (causing less than 2VDC to be present at JP4 pins 1 and 4) to inform the other PAPI Light Units to shut down. The other Light Units will display "EEE" to indicate they are being shut down by another Light Unit in a tilt situation.



Note

Connector JP4 may be momentarily removed from any Light Unit to isolate problems while troubleshooting. Disconnecting the JP4 plug from a light box will simulate that box NOT being in a tilt condition and the rest of the system's light units should turn on after about 25 seconds.

The tilt signal shutdown function is not used in Canadian applications.

3.6.2 Single-Channel PAPI Inclinometer Overview

The Inclinometer Board contains a dual axis inclinometer that provides instrumentation grade performance for leveling applications. It contains a silicon-based chip that measures the tilt angle and transmits it to the Single-Channel PAPI Control board over a digital interface.

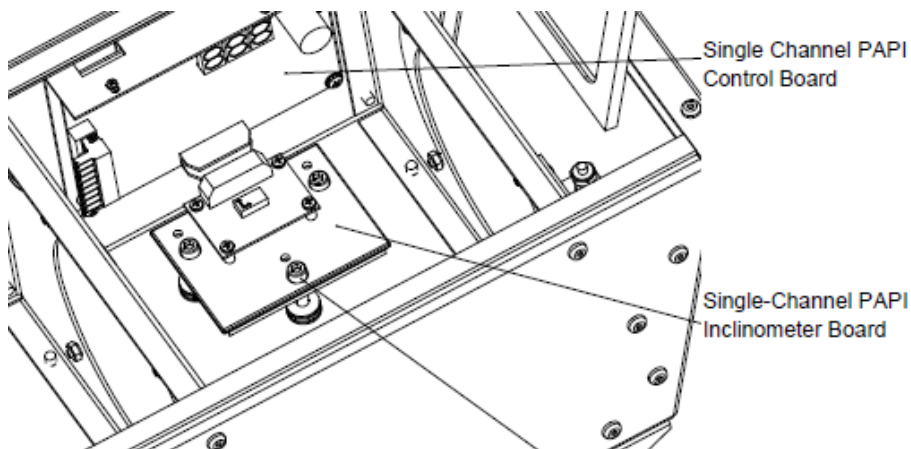

4.0 Siting the PAPI System

This section provides guidance on how to determine the physical location for Light Units and the Power Control Unit. The Power Control Unit is only used for Style A systems, Style B systems require Light Units only.

4.1 Siting Considerations

When viewed from the approach end, the PAPI system must be located on the left-hand side of the runway as shown in [Figure 8](#). The PAPI may be located on the right side of the runway if siting problems exist, such as conflicts with runways or taxiways. The PAPI must be sited and aimed so that it defines an approach path with adequate clearance over obstacles and a minimum threshold crossing height.

If the runway has an established ILS glideslope, refer to [Siting a PAPI with an ILS Glideslope](#) section. The PAPI must be installed so that the visual glideslope coincides (as much as possible) with the electronic glideslope. If there is no ILS on the runway, refer to [Siting PAPI on Runways Without ILS](#) section. The PAPI's glideslope must be chosen to ensure the on-course signal of the PAPI provides adequate clearance over obstacles.

4.1.1 Distance of the PAPI Light Units from the Runway Edge

See [Figure 22](#). The Light Unit nearest the runway must be no closer than 50 feet (15.24 m) (+10, -0 feet) (+3.048, -0 m) from the runway edge or to other runways or taxiways. This distance may be reduced to 25 feet (7.62 m) for small general aviation runways used by non-jet aircraft. Heliports or military airports may require steeper angles. An optional elevation kit is available for glide angles greater than 5 degrees.

4.1.2 Lateral Spacing of the PAPI Light Units

The PAPI Light Units must have a spacing between Light Units of 20 to 30 feet (6.096 to 9.144 m). Regardless of the actual spacing chosen, the distance between Light Units must not vary by more than 1 foot (304.8 mm).

4.2 Siting a PAPI with an ILS Glideslope

When a runway has an established ILS electronic glideslope, the PAPI on-slope signal should coincide, as much as possible, with that for the ILS. To accomplish this, place the PAPI at the same distance (tolerance of ± 30 feet or ± 9.144 m) from the threshold as the virtual source of the ILS glideslope and aim at the same angle as the ILS glideslope.

Refer to [Figure 8](#). This procedure must be modified for runways that serve aircraft in height group 4 because of the eye-to-antenna distance. For these runways, the distance of the PAPI from the threshold must equal the distance to the virtual source of the ILS glideslope plus an additional 300 feet (91.44 m) (+50 feet, -0 feet) (+15.24 m, -0 m). Calculations should be performed to ensure that the site chosen provides adequate obstacle clearance and threshold crossing height. Also see FAA AC 150-5340-30 diagram with same name.

Figure 8: PAPI Obstacle Clearance Surface

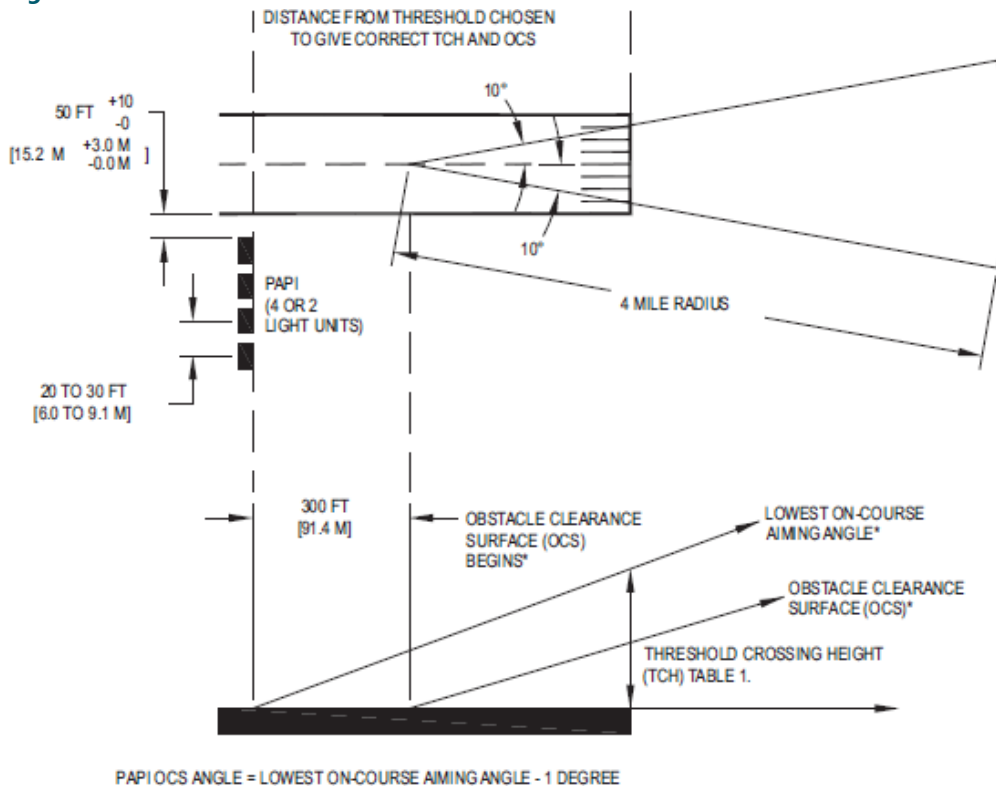

Table 2: Threshold Crossing Height

Type of Aircraft	Cockpit-to-Wheel Height	Visual Threshold Crossing Height	Remarks
Height Group 1 (General aviation, small commuters, corporate turbojets)	10 feet (3.048 m) or less	40 feet (12.2 m) (+5 ft, -20 ft) (+1.524 m, -6.1 m)	Many runways less than 6,000 ft (1828.8 m) long with reduced widths and/or restricted weight bearing which would normally prohibit landings by larger aircraft
Height Group 2 (F-28, CV 340/440/580, B-737, DC 8/9)	15 feet (4.6 m)	45 feet (13.7 m) (+5 ft, -20 ft) (+1.524 m, -6.1 m)	Regional airport with limited air carrier service
Height Group 3 (B 707/720/727/757)	20 feet (6.1 m)	50 feet (15.24 m) (+5 ft, -15 ft) (+1.524 m, -4.6 m)	Primary runways not normally used by aircraft with ILS glideslope-to-wheel heights exceeding 20 ft (6.1 m)
Height Group 4 (B-747/767, L-1011, DC-10, A-300)	Over 25 feet (7.6 m)	75 feet (22.9 m) (+5 ft, -15 ft) (+1.524 m, -4.6 m)	Most primary runways at major airports.

4.3 Siting PAPI on Runways Without ILS

When the runway doesn't have an ILS glideslope, the PAPI must be sited and aimed so that it defines an approach path which will produce the required threshold crossing height and clearance over any obstacles in the approach area.

4.3.1 Threshold Crossing Height (TCH)

See [Figure 8](#) . The TCH is the height of the lowest on-course signal at a point directly above the threshold and the runway centerline. The minimum allowable TCH depends on the height group of the aircraft using the runway, and is shown in [Table 2](#) . The glideslope of the PAPI must provide the proper TCH for the most demanding aircraft height group using the runway.

4.3.2 Glideslope Angle

The standard visual glideslope angle for the PAPI is 3 degrees. For non-jet runways, this may be raised to 4 degrees if required to provide obstacle clearance.

4.3.3 Distance of PAPI from Threshold

The following method can be used to determine the PAPI installation distance from the runway threshold provided there are no obstacles in the area from which the PAPI signals can be observed, no differences in elevation between the threshold and the installation zone of the PAPI or between the units, or reduced length of runway. The distance of the PAPI Light Units from the threshold (D1) can be calculated from the equation:

$$D1 = TCH \times \cotan(\text{angle of lowest on-course signal})$$

where the TCH is the threshold crossing height for the most demanding aircraft using the runway. Refer to [Table 2](#) . The angle of the lowest on-course signal is determined as follows:

- For the L-880 PAPI system the angle of the lowest on-course signal will be the aiming angle of the third Light Unit from the runway minus 1.5 minutes or arc.



Note

The subtraction of 1.5 minutes of arc takes into account the width of the transition sector (3 minutes of arc) between the white and red part of the PAPI light beam.

The lowest possible on-course signal is $3\frac{1}{2} = 1.5'$ lower than the aiming angle.

- For the L-881 PAPI system this angle will be the aiming angle of the outside Light Unit minus 1.5 minutes of arc.

4.3.4 Obstacle Clearance Surface

Position and aim the PAPI so that no risk exists of an obstruction being located in an area where the PAPI signals can be observed. Make a survey of the site to determine if an obstacle is present in the area where you can observe the PAPI signals.

See [Figure 8](#) . This obstacle clearance surface begins 300 feet (91.44 m) in front of the PAPI Light Units (closer to the threshold) and proceeds outward into the approach area at an angle of 1 degree less than the lowest on-course signal. This surface extends 10 degrees on either side of the runway centerline to a distance of 4 miles (6.44 km) from the point of origin.

If an obstruction penetrates the obstacle clearance surface and cannot be removed, then the re-aim the glide slope angle or move the PAPI system further from the threshold. By moving or re-aiming the PAPI, re-position the obstacle clearance surface so that it will not be penetrated by an obstruction. See Figure 9 .

Figure 9: Obstacle Clearance Surface

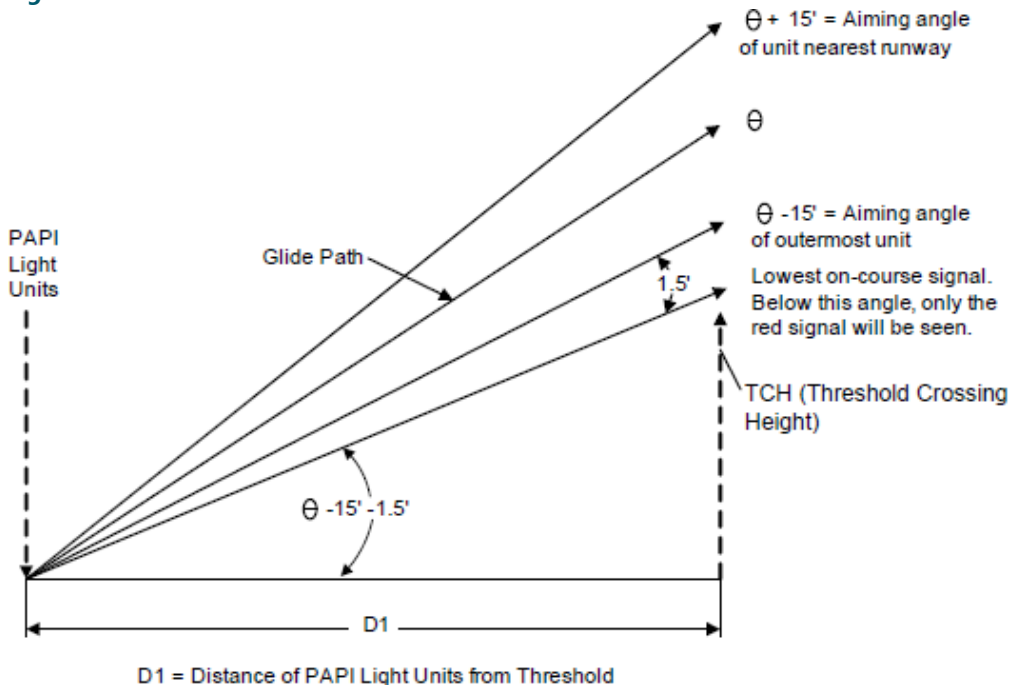

The 1.5' is one-half the width of the transition sector of the light beam. The transition between the white to red part of the beam is 3 minutes of arc ($3'$). Hence the additional 1.5' must be taken into account in calculating $D1$.

- For L-881: $D1 = TCH \times \cotan (\Theta - 15' - 1.5')$



Note

For the L-880 PAPI system, the lowest on-course signal will be the aiming angle of the third Light Unit from the runway minus 1.5'. For a standard L-880 installation the lowest on-course signal will be $\Theta - 10' - 1.5'$. For Height Group 4 aircraft this angle will be $\Theta - 15' - 1.5'$.

- For L-880 (Standard Installation): $D1 = TCH \times \cotan (\Theta - 10' - 1.5')$
- For L-880 (Ht. Group 4 aircraft): $D1 = TCH \times \cotan (\Theta - 15' - 1.5')$

4.3.5 Reduction of Beam Coverage for Obstacle Avoidance

A PAPI system may require a reduction of the horizontal beam coverage because of an obstacle in the approach area. If this is the case, special consideration should be given to the following factors when determining the required system cutoff angle(s):

- Type and location of the obstacle with respect to the area where the PAPI signals can be observed
- Wingspan of aircraft using the runway
- Vertical pitch of the glide slope
- Installation tolerances
- Position of the PAPI system
- Additional safety considerations
- Origin of the cutoff angle should be either the outermost or innermost unit (whichever is closest in azimuth to the obstacle)
- Cutoff angles should be FAA approved

If a reduction in the horizontal beam coverage is required, contact the ADB SAFEGATE sales department for further details.

4.4 Siting Tolerances

Siting tolerances involve azimuth aiming, mounting height tolerance, PAPI tolerance along a line perpendicular to the runway, and correction for the runway longitudinal gradient.

4.4.1 Azimuth Aiming

Each Light Unit shall be aimed outward into the approach zone on a line parallel to the runway centerline within a tolerance of $\pm 1/2^\circ$.

4.4.2 Mounting Height Tolerance

The beam centers of all Light Units shall be within ± 1 inch (25.4 mm) of a horizontal plane. The beam center is located at the front pop-nail (rivet) as depicted on Figure 10. This plane shall be within ± 1 foot (304.8 mm) of the elevation of the runway centerline at the intercept point of the visual approach angle with the runway except for additional siting considerations. Refer to [Additional Siting Considerations](#) section. The Light Unit EMT leg length is chosen by the installer to insure the proper mounting height is achieved.

Figure 10: Light Unit Mounting Height

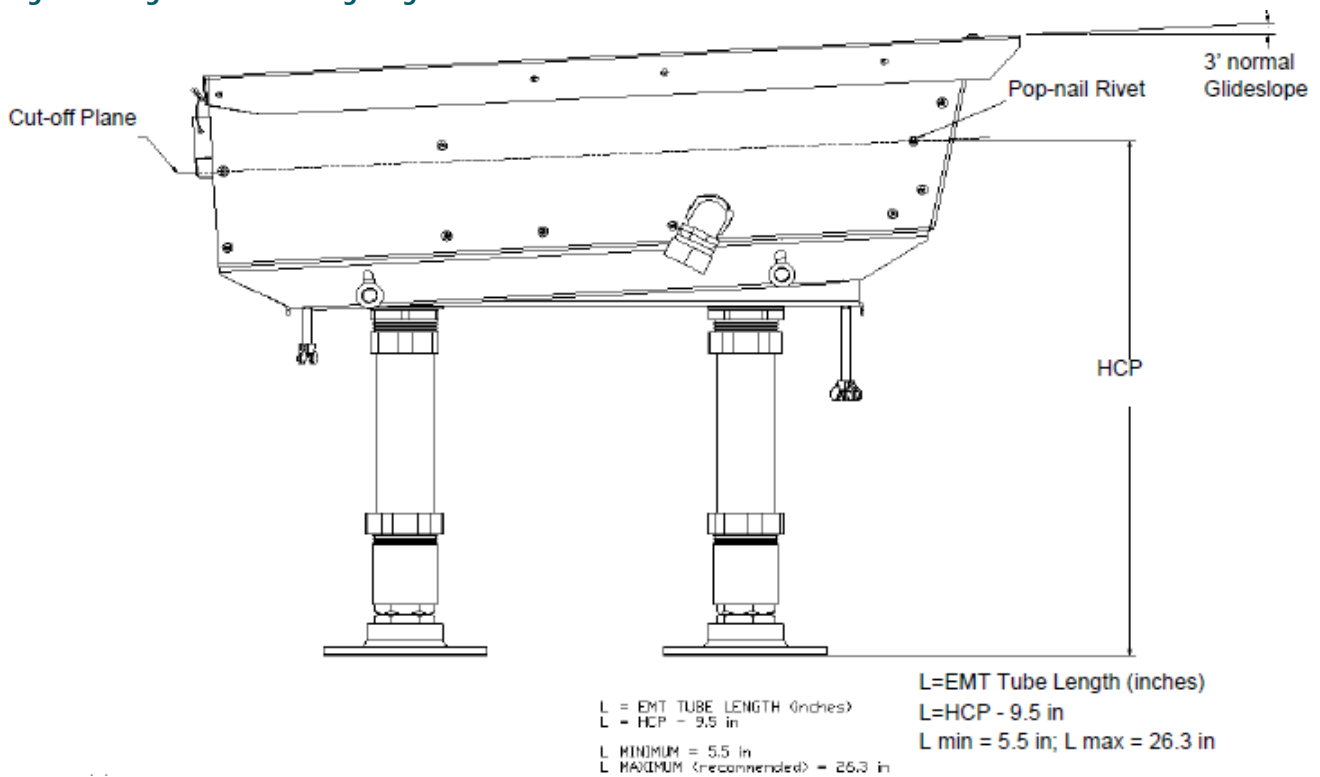

4.4.3 PAPI Tolerance Along Line Perpendicular to Runway

The front face of each Light Unit in a bar shall be located on a line perpendicular to the runway centerline within ± 6 inches (152.4 mm).

4.4.4 Correction for Runway Longitudinal Gradient

See [Figure 11](#). Refer to AC 150/5435-30 (current edition). On runways where a difference exists in elevation between the runway threshold and the elevation of the runway centerline adjacent to the PAPI, you may need to adjust the location of the Light Units with respect to the threshold to meet the required obstacle clearance and TCH.

Figure 11: Correction for Runway Longitudinal Gradient

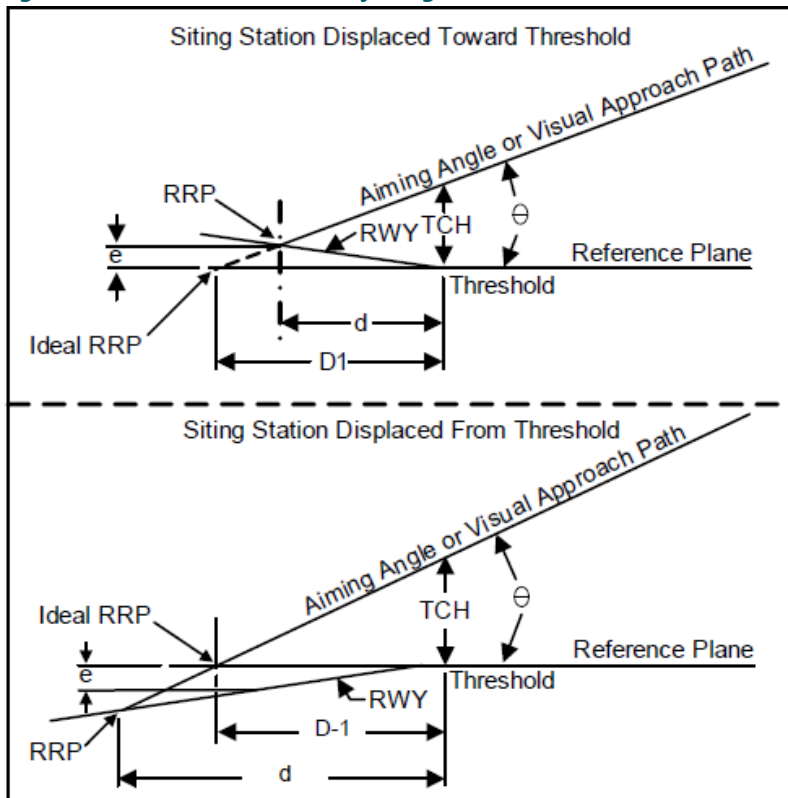

LEGEND

- RWY = Runway Longitudinal Gradient
- THC = Threshold Crossing Height
- RRP = Runway Reference Point (where aiming angle or visual approach path intersects runway profile)
- D1 = Ideal (zero gradient distance of PAPI Light Units from threshold)
- d = Adjusted Distance of PAPI Light Units from Threshold
- e = Elevation Difference Between Threshold and RRP
- Θ = Aiming Angle

If the condition exists, perform the following steps to compute the change in the distance from the threshold required to preserve the proper geometry:

1. Obtain the runway longitudinal gradient. This can be done by survey or obtained from airport obstruction charts or as-built drawings.
2. Determine the ideal (zero gradient) distance from the threshold in accordance with the preceding instructions.
3. Assume a level reference plane at the runway threshold elevation. Plot the location determined in Step 2.
4. Plot the runway longitudinal gradient.
5. Project the visual glideslope angle to its intersection with the runway longitudinal gradient. Then solve for the adjusted distance from the threshold either mathematically or graphically. Refer to [Mounting Height Tolerance](#) section.
6. Verify the calculated location gives the desired threshold crossing height.

4.5 Additional Siting Considerations

Below are additional siting considerations.

- Where the terrain drops off rapidly near the approach threshold and severe turbulence is experienced, locate the PAPI farther from the threshold to keep the aircraft at the maximum possible threshold crossing height.
- On short runways, the PAPI should be as near the threshold as possible to provide the maximum amount of runway for braking after landing.
- Contact your ADB SAFEGATE sales representative for additional guidance if the PAPI Light Units must be installed at locations where snow is likely to obscure the light beams.
- Since the effectiveness of the PAPI system is dependent on the optical red and/or white signal pattern from the Light Units, make sure that no other lights are close enough to confuse the pilot.

Figure 12: Example PAPI Installation



5.0 Installation

This section provides instructions for installing the PAPI Light Units and the Style A Power Control Unit (PCU). Refer to airport project plans and specifications for specific installation instructions. The installation must conform to the applicable sections of the National Electric Code and local codes.

5.1 Safety Considerations

Read this installation section thoroughly before installing the equipment. A thorough understanding of system components and their requirements will promote safe and efficient installation. See FAA AC 150/5340-30 (current edition) and site plans and specifications for additional guidance on PAPI installation.

5.1.1 Installation

Refer to the system print package. The system print package supplied with the Small-frame SGRS system provides detailed information about the system components, and wiring.

Assembly prints reflect the actual built unit and also includes the Bill of Material including all of the components used to assemble the final product.

System externals generally show the connections exterior to the enclosures. These prints illustrate the connections typically performed by the electrical contractor. This includes regulator control wiring, airfield circuit cable wiring, and optional monitoring wiring. Internal wiring diagrams illustrate how the components are wired and connected within the enclosures.

5.2 Inspect the Equipment

Upon receipt of the PAPI system and before unpacking it, verify that the labeled equipment matches the bill of lading. Inspect all items for damage. Report any damage immediately to the carrier and send a copy to ADB Safegate.

5.2.1 What's Included

Table 3: Components Supplied by ADB

Component	L-880		L-881	
	Style A	Style B	Style A	Style B
Lighting Unit Assembly	4	4	2	2
Mounting Flange	8	8	4	4
Mounting Spacer	8	8	4	4
Frangible Coupling	8	8	4	4
Compression Coupling	8	8	4	4
Field Splice Kit (Quantity)	94A0235/3 (1)	94A0255/1 (4)	94A0235/4 (1)	94A0255/1 (2)

5.2.2 Required Materials Supplied by Others

Installing either the L-880 or the L-881 PAPI requires the following items, which must be supplied by others:

- 3/8-16 anchor bolts, 2 per leg; either expansion bolts and sleeves or J-bolts
- 2" EMT pipe, one length per leg (two legs per PAPI Light Unit)
- AWG 16, 600V interconnecting wire between Light Units and Power Control Unit (Style A only)
- Shrink tubing
- Butt splices
- Aviation orange paint (to paint 2" EMT pipe); 12 oz. spray cans of orange paint are also available from ADB SAFEGATE (P/N95A0008)
- 9V or 12V battery (optionally used to power Light Unit PC boards during alignment)

5.3 Installing the PCU Power Control Unit (Style A Only)

Refer to site plans and contractor documents to determine where the PCU (Power Control Unit) will be installed and where and how to route the wiring. See [Schematics](#) section. The PCU must be installed on a concrete slab that extends at least 23" (584mm) below the frost line and 14" (356mm) beyond the PCU housing to minimize damage by mowers and similar equipment. The PCU is secured to the concrete base with four bolts, two for each leg.



Note

Instead of using expansion bolts, it is permissible to insert 3/8–16 x 6-inch anchor J-bolts into the concrete before it sets. See the frangible coupling dimensions on the drawing in [Schematics](#) section, to determine the proper locations for the bolts.

5.4 Installing the Light Units (Style A and B)

Refer to site plans and contractor documents to determine where the Light Units will be installed and where and how to route the wiring.

Each PAPI Light Unit must be installed on a concrete slab that extends at least 12" (305mm) below the frost line and 12" (305mm) beyond the Light Unit's housing to minimize damage by mowers and similar equipment. The PAPI Light Units are secured to the concrete base with four bolts, two for each leg. The bolt-hole pattern must be parallel to the runway centerline for proper orientation of the PAPI.



Note

See [Mounting Height Tolerance](#) section and [Figure 10](#). The contractor supplies and installs the EMT tube—2" (50.8mm) diameter (2-3/16" OD); minimum length, 5.5" (140mm); maximum recommended length, 26.3" (670mm). Determine exact length at installation to compensate for uneven elevation above the runway. The 2" EMT tube extends into the frangible coupling 3-1/4" (82.55mm) and 1-1/2" (38.1mm) into the nut and ferrule compression joint to ensure stable installation. An EMT cut length of 11" (279mm) will result in a beam height of 20.5" (521mm) when set at a nominal 3° slope.

Instead of using expansion bolts, it is permissible to insert 3/8–16 x 6-inch anchor J-bolts into the concrete before it sets. See the frangible coupling dimensions on the drawing in [Schematics](#) section to determine the proper locations for the bolts.

To cast the concrete pad and install anchors:

1. Stake out the longitudinal axis of the Light Units parallel to the runway centerline.
2. Dig the foundation hole as shown on the drawing in [Schematics](#) section.
3. Place foam in the pit to absorb frost heave below the central part of the slab.
4. Style B installation only: Place L-867 light base/conduit elbows (to separately house each isolation transformer) or conduit for cables.
5. Place rebar to strengthen concrete.

6. Pour the concrete and allow it to harden for at least 24 hours.
7. After the concrete sets up, draw a longitudinal axis (in accordance with the axis staked out on the ground) on the upper surface of the pad.
8. Draw a transverse axis perpendicular to the other axis.
9. Using plywood or other equivalent material, construct a positioning guide according to the Positioning Plate Detail on the drawing in [Schematics](#) section.
10. Lay the positioning plate on the pad; center it by positioning the central hole at the intersection of both axes.
11. Align the plate along the longitudinal axis using the V-notches in the plate.
12. Mark the locations for the four bolts (2 for each leg) required for the PAPI base.
13. Drill the holes to the diameter and depth required for the expansion sleeves and insert the sleeves.
14. See [Schematics](#) section to install the mounting flanges (Item 3) to the concrete slab.
15. Install the frangible couplings by fully threading them into the mounting flanges.
THE USE OF AN ANTI-SEIZE COMOUND IS STRONGLY RECOMMENED
16. Remove the nut and ferrule compression ring from each of the frangible couplings. For each section of EMT, first slide on the nut and then the ferrule compression ring. Insert the EMT at least 3 1/4 inches into the frangible coupling to insure a stable installation. Thread the nut onto the frangible connector and hand tighten the compression fitting. This will be fully tightened later.
17. To reduce corrosion, paint the EMT tube international orange, color #12197, according to Federal Standard 595A. International orange paint is available from ADB SAFEGATE in 12 oz. (0.3kg) cans (P/N 95A0008).

5.5 Attach the PAPI Light Unit Housing to the Legs

DO NOT DISASSEMBLE THE PAPI LIGHT UNIT FROM IT'S BASE MOUTNING PLATE. The light unit and it's base plate are integrally matched for optimum performance. The compression couplings are factory tightened to the base and do not require assembly in the field.

1. Turn the light unit upside down. Remove the EMT compression fitting nuts and ferrule compression rings. For each section of EMT, first slide on the nut and then the ferrule compression ring. Place the Light Unit onto the two sections of EMT. Insure that the EMT is fully inserted into the compression fitting to insure a stable installation. Thread the nuts onto the compression fittings and hand tighten the compression fitting.
2. Fully tighten the Light Unit compression fittings and the frangible coupling compression fittings. The Light Unit should now be rigidly mounted and should not sway or rock back and forth.
3. Tighten the connection assembly.

5.6 System External Wiring Connections

5.6.1 Style A Wiring Between Power Control Unit and the Light Unit



WARNING

- Before making any wire connections, make sure that you turn off all incoming power sources. Failure to observe this warning may result in personal injury, death, or equipment damage.

Grounding Units

Each PAPI light unit must be grounded. To ground each light unit: Attach a AWG 14 (minimum) ground wire to the ground lug located on the rear side of each light unit . The Earth Ground connection may be input directly into the Power Control Unit with the incoming power wiring (and connected to the internal panel ground lug) or alternately, externally connected to the external ground lug on the enclosure.

Connecting External Wiring

All installation wiring should conform to the applicable sections of the National Electric Code and Local Codes. Make wire connections as shown in the appropriate drawing:

- [Schematics](#) section for the L-881 PAPI
- [Schematics](#) section for the L-880 PAPI

Input voltage is supplied to the box at TB1-1 and TB1-3. Note: No input wire is connected to TB1-2. Route cable through the flexible conduit assemblies.

Note
All external wiring must be a minimum of 16 AWG/600V.

See the drawings in [Schematics](#) section and [Figure 13](#), and [Figure 14](#) for a suggested method of connecting the wires between the Power Control Unit and the Light Unit and equipment supplied by others. See [Table 3](#) . Field splice kit(s) are separately provided with the PAPI system for use in attaching interconnecting wiring.

Figure 13: L-880/L-881, Style A, Power Control Unit (PCU) External Connections - 117A0047

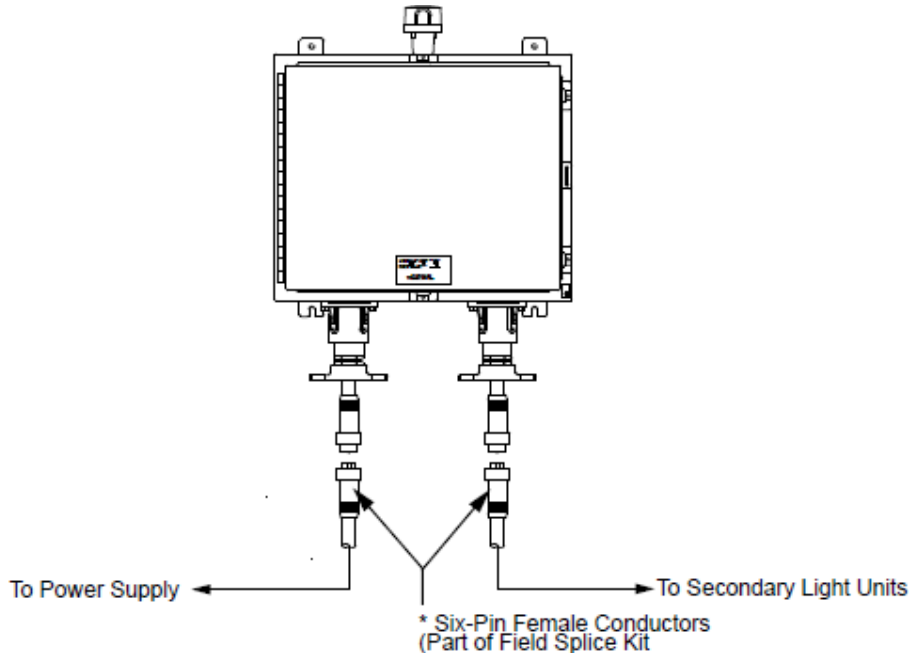
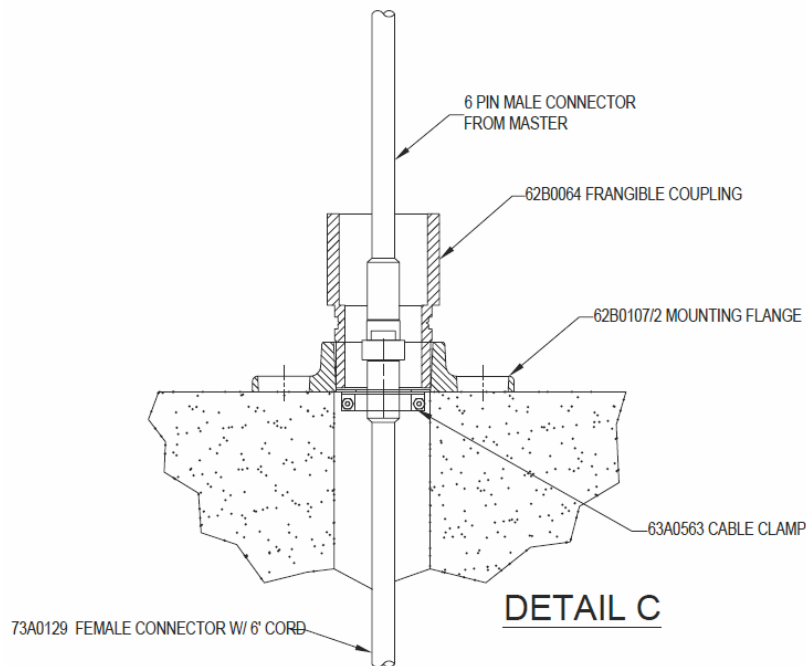

Figure 14: L-880/L-881, Style A, Power Control Unit (PCU) Frangible Connection - 117A0047



5.6.2 Connecting Wiring Between the PAPI Light Units Through Conduit

Each PAPI Light Unit is shipped with multi-conductor cable connected to the unit. This cable must be disconnected from the Light Unit and cut to length before it can be pulled through the protective flexible conduit required for installation. This is also because the factory-installed connector is too large to fit through the conduit. To install the flexible conduit:

1. See [Figure 18](#) . Disconnect the individual multi-conductor cable wires from the Control Board by first removing terminal blocks JP1 and JP4.
2. Note wire colors and terminal numbers for each wire. Loosen the screws holding the wires to the terminal blocks and pull the wires free.
3. Temporarily plug the terminal blocks back into the Control Board.
4. Use a pair of wire cutters (or a similar tool) to cut the strain-relief bindings inside the Light Unit. Take care not to nick the insulation or wires.
5. Pull the multi-conductor cable out of the Light Unit enclosure, bending the cable if necessary as it enters the conduit elbow on the side of the enclosure.
6. Slide the multi-conductor cable through the appropriate length of flexible conduit necessary to attach the flexible conduit to the elbow on the Light Unit. Pull the multi-conductor cable back into the Light Unit.
7. Attach the flexible conduit to the Light Unit, tightening the fittings securely.
8. Remove 8 inches (203mm) of insulation from the end of the cable. Strip the end of each wire 0.3 inches (7.6mm).
9. Re-secure the multi-conductor cable internally with strain-relief ties .
10. Reattach the multi-conductor cable wires to terminal blocks JP1 and JP4. Refer to [Figure 16](#).
11. Reinsert the terminal blocks onto the Control Board.



Note

Canadian PAPI use a 2-conductor cable that is directly attached to the secondary of a 300W isolation transformer.

5.6.3 Style B Wiring Between Each Light Unit



WARNING

- Before making any wire connections, make sure that you turn off all incoming power sources. Failure to observe this warning may result in personal injury, death, or equipment damage.

This subsection describes series circuit wiring requirements.

Grounding the Light Units

Each PAPI light unit must be grounded. To ground each light unit, attach a AWG 14 (minimum) ground wire to the ground lug located on the rear side of each light unit.

Using Isolation Transformers

One 300W L-830 or L-831 isolation transformer is required to connect the series lighting circuit to each PAPI light unit.

Connecting External Wiring

All installation wiring should conform to the applicable sections of the National Electric Code and local codes. Make wire connections as shown in the appropriate drawing:

- [Figure 27](#) or [Figure 29](#) for the L-881 PAPI
- [Figure 28](#) or [Figure 30](#) for the L-880 PAPI



Note

All external wiring must be a minimum of 16 AWG/600V.

See the drawings in [Schematics](#) section for a suggested method of connecting the wires between each Light Unit. See [Table 3](#). Field splice kit(s) are provided for both L-880 and L-881 PAPI installation.

Light Unit Wiring

Install the multi-conductor cable on each Light Unit as described in [Connecting Wiring Between the PAPI Light Units Through Conduit](#).

Figure 15: L-880/L-881 PAPI Light Unit Power Cable Frangible Connection

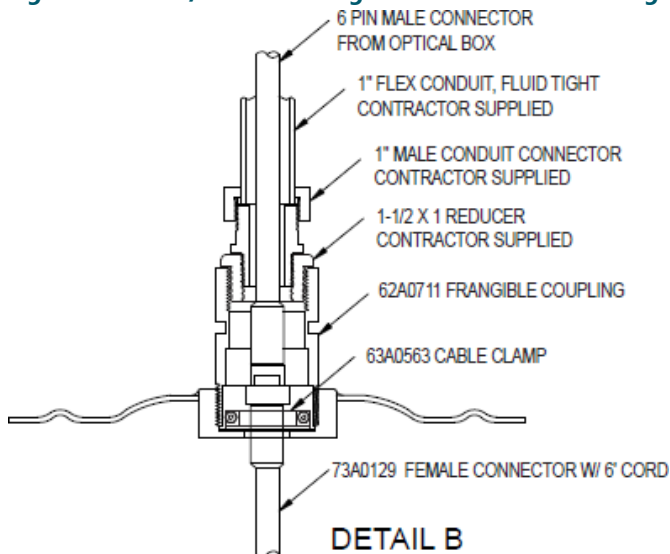

5.7 Align the PAPI



Note

The Control Board display reads directly in degrees with one hundredth (.XX) of a degree resolution. [Table 6](#) is provided to convert the readout, which is in decimal degrees, to minutes:

Examples:

Suppose that an angle of 3°35' is desired. To obtain this setting, adjust the Light Unit's glide angle until 3.58 is displayed on the readout.

Suppose that an angle of 3°15' is desired. To obtain this setting, adjust the Light Unit's glide angle until 3.25 is displayed on the readout.



Note

If the readout shows LO, this indicates that the glide slope is negative (PAPI aimed toward the ground). If the readout shows HI, this indicates that the glide slope is greater than 9.99 degrees from horizon.

Before aligning the PAPI Light Units, Please thoroughly read [Operation](#) section of this manual to familiarize yourself with the digital display and push buttons operation of the PAPI control board.

Each PAPI Light Unit contains a digital LED readout. This display is used to set the vertical glide angle and to horizontally level each Light Unit. See [Understanding the LED Readout](#) for additional details. The glide angle varies by location. To determine the correct angle, refer to site-specific documents, [Table 4](#) . and [Table 5](#) .

The PAPI's LED display shows three digits representing degrees, tenths of a degree and hundredths of a degree.



Note

For elevation angles above 5 degrees, order an elevation extension kit (P/N 94A0496) for each Light Unit. See [Single Channel PAPI Parts](#) section for location where elevation extension kit brackets are added.

After determining the proper angle for the PAPI light box:

5.7.1 Initial Setup

If field power is available, connect input power to the PAPI. If power is not available, connect a 9V or 12V battery to the Control PCB as shown in [Figure 12](#) . Connect the battery to terminal block JP2; positive to Pin 1 and negative to Pin 2.



Note

If the battery is not connected correctly the Light Unit boards will not operate. This will NOT damage the Light Unit circuit board due to polarity protection on the input of terminal block JP2.

1. Loosen, but DO NOT REMOVE, the four (4) base bolts ([Figure 10](#)).
2. Finger tighten the four (4) base bolts.
3. Lower the single rear threaded adjusting rod completely and make sure the bottom of the light box is resting on the base.



CAUTION

- During this step, do not apply excessive torque to the threaded rods. this may bend or damage the rods or the light unit box.

4. Raise the two (2) front threaded adjusting rods until the front of the Light Unit is raised from the base as far as possible. At this point, the Light Unit should be set at maximum glide angle, with the back of the Light Unit lowered as far as possible and the front of the unit raised as far as possible.
5. Lower the two (2) front threaded adjusting rods three (3) full turns and gently press the front of the Light Unit down until it rests on the tips of the adjusting rods.



Note

Initial setup is complete.

5.7.2 Adjusting the Azimuth Angle

The following instructions require the Light Unit's circuit board to be powered either by the system input power or by use of a battery as described in the previous section.

If powered by the system input power, the Light Unit's three 105W lamps may initially light and then extinguish after 30 seconds. This is normal and can be ignored. The LED display on the Light Units' circuit board should be displaying an angle.

1. With the Light Unit powered as explained above, cycle the LED display to show the AZIMUTH angle.
2. Torque the one (1) FRONT base bolt below the circuit board to 132 in-lb.
3. Lower the one (1) front threaded adjustment rod nearest to this bolt so that its tip is not touching the Light Unit bottom.
4. Adjust the opposite FRONT threaded adjustment rod (near the power cord entry) until the AZIMUTH angle on the LED display reads 0.00 degrees +/- 0.07 degrees.
5. Torque the one (1) FRONT base bolt near the power cord entry to 132 in-lb.
6. If the AZIMUTH angle is not correct after the base bolt has been tightened, loosen the one (1) front base bolt on the circuit board side by $\frac{1}{4}$ to $\frac{1}{2}$ turn and use the front circuit board side threaded adjustment rod to fine tune the angle. Re-torque the base bolt and re-adjust if necessary until the AZIMUTH angle is within +/- 0.07 degrees.
7. Lower the two (2) front threaded adjustment rods until their tips are about $\frac{1}{2}$ inch below the Light Unit.

5.7.3 Adjusting the Glide Angle

1. Cycle the LED display to show the GLIDE angle.
2. Adjust the REAR threaded adjustment rod until the desired GLIDE angle is displayed on the LED display within +/-0.03 degrees.
3. Tighten each of the two rear base bolts $\frac{1}{4}$ turn and re-check the angle. Re-adjust if necessary.
4. Repeat the previous step until the bolts are tightened to a torque of 132 in-lb. and the GLIDE angle is displayed within +/- 0.03 degrees.
5. Cycle the LED display to show the AZIMUTH angle. Re-adjust if necessary.

5.7.4 Saving the Glide Angle to Memory

1. See [Figure 17](#) . After all adjustments are complete, press the SET ANGLE pushbutton for five seconds until **CAL** is displayed. This stores the current glide angle in memory so that if a Light Unit becomes vertically misaligned, the

inclinometer circuitry will disable the Light Unit. The horizontal (Azimuth) angle is hard coded to disable the Light Unit if the unit is tilted more than 1.75 degrees in either direction.

2. When alignment is complete, remove the battery from terminal block JP2 (if used).
3. Repeat the alignment procedure for each of the Light Units.

Table 4: Aiming Angles for L-880 PAPI Light Units

L-880 (4 box) PAPI	Aiming Angle (Minutes of Arc) (Standard Installation)	Aiming Angle (Minutes of Arc) (Height Group 4 Aircraft* on Runway with ILS)	Note
Unit nearest runway	30' (0.50°) above glide path	35' (0.58°) above glide path	A
Next adjacent unit	10' (0.17°) above glide path	15' (0.25°) above glide path	A
Next adjacent unit	10' (0.17°) below glide path	15' (0.25°) below glide path	A
Next adjacent unit	30' (0.50°) below glide path	35' (0.58°) below glide path	A

A. Refer to [Table 2](#) .



Note

60 minutes of arc = 1 degree (60' = 1°)

Table 5: Aiming Angles for L-881 PAPI Units

L-881 (2 box) PAPI	Aiming Angle (Minutes of Arc) (Standard Installation)
Unit nearest runway	15' (0.25°) above glide path
Unit farthest from runway	15' (0.25°) below glide path



Note

60 minutes of arc = 1 degree (60' = 1°)

Figure 16: Light Unit Control Board

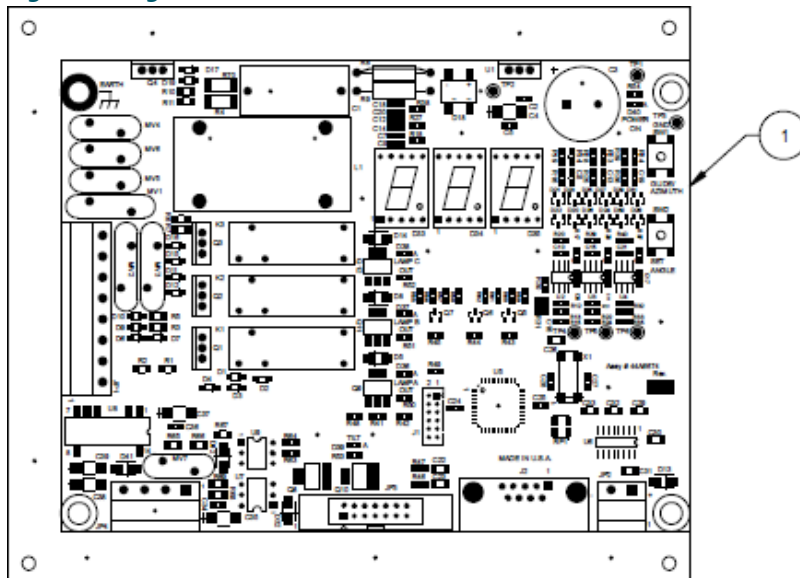

Figure 17: Control Board Pushbuttons

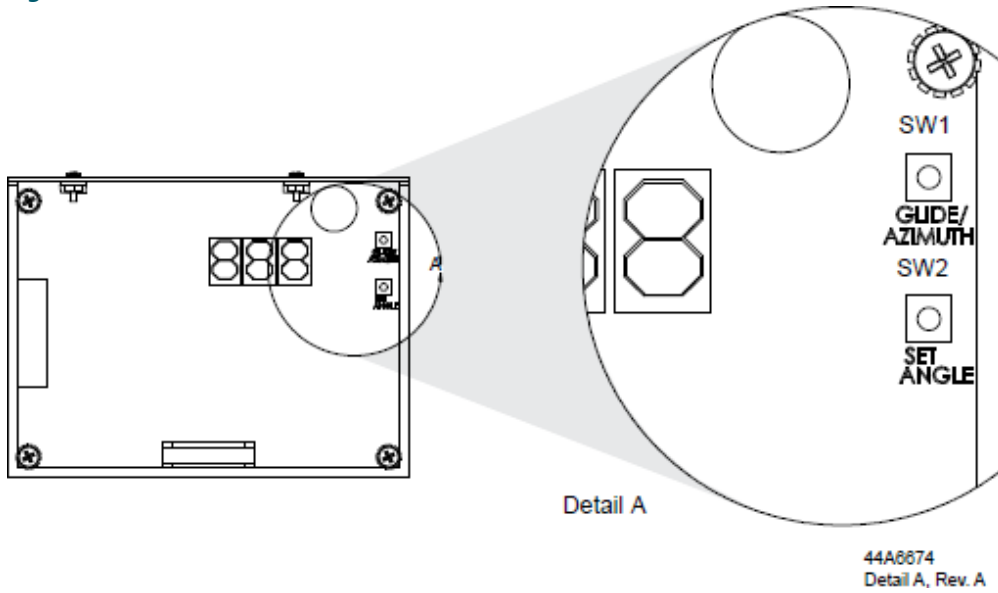

Table 6: Conversion from Decimal Degrees to Minutes

Decimal Degrees	Minutes	Decimal Degrees	Minutes
0.02	1	0.52	31
0.03	2	0.53	32
0.05	3	0.55	33
0.07	4	0.57	34
0.08	5	0.58	35
0.10	6	0.60	36
0.12	7	0.62	37
0.13	8	0.63	38
0.15	9	0.65	39
0.17	10	0.67	40
0.18	11	0.68	41
0.20	12	0.70	42
0.22	13	0.72	43
0.23	14	0.73	44
0.25	15	0.75	45
0.27	16	0.77	46
0.28	17	0.78	47
0.30	18	0.80	48
0.32	19	0.82	49
0.33	20	0.83	50
0.35	21	0.85	51
0.37	22	0.87	52
0.38	23	0.88	53
0.40	24	0.90	54

Table 6: Conversion from Decimal Degrees to Minutes (Continued)

Decimal Degrees	Minutes	Decimal Degrees	Minutes
0.42	25	0.92	55
0.43	26	0.93	56
0.45	27	0.95	57
0.47	28	0.97	58
0.48	29	0.98	59
0.50	30	1.00	60

6.0 Operation

This section provides operating information for the PAPI system, including important guidelines for normal operation, preparation for heavy snowfall and criteria for system deactivation.

- For **Style A** PAPI units, follow the steps for initial startup using local control, remote control operation and optional interlock relay in [Initial Startup Using Local Control \(Style A\)](#) through [Set Up and Test Optional Interlock Relay](#).
- For **Style B** PAPI units, follow the steps for initial startup discussed in Section [Adjusting the Over Current Detection Level](#).

6.1 Operation Safety Considerations



WARNING

Only qualified personnel, physically capable of operating the equipment and with no impairments in their judgment or reaction times, should operate this equipment.

- Read this manual completely before operating the equipment. A thorough understanding of system components and their operation will help you operate the system safely and efficiently.
- Before starting this equipment, check all safety interlocks, fire-detection systems and protective devices such as panels and covers. Make sure all devices are fully functional. Do not operate the system if these devices are not working properly. Do not deactivate or bypass automatic safety interlocks or locked-out electrical disconnects.
- Never operate equipment with a known malfunction.
- Do not attempt to operate or service electrical equipment if standing water is present.
- Use this equipment only in the environments for which it is rated. Do not operate this equipment in humid, flammable or explosive environments unless it has been rated for safe operation in these environments.
- Never touch exposed electrical connections on equipment while the power is ON.

6.1.1 Normal Operation

The PAPI system must operate continuously as long as the runway is in service.

- The **Style A** system is controlled by a photocell that automatically sets the system to 100% intensity during daytime and either 5% or 20% intensity at night.
- The **Style B** system operates at any intensity selected by the CCR. It is recommended that a five-step CCR be used to power the Style B PAPI system.

6.1.2 Preparation for Heavy Snowfall

The single-channel PAPI should operate continuously at normal standby brightness even when the runway is not in use, permitting any snow, ice or condensation to melt and drain off.

If snowfall is expected to bury the Light Units, mark the location of the Light Units with sticks or flags—approximately 7 ft. (2.1m) high—to prevent damage by snow removal equipment.

6.1.3 Criteria for System Deactivation

Any Light Unit in which one or two of the three lamps have failed can still be regarded as operational, pending repair and provided the Light Unit is continually monitored.

Should the system show more serious defects, it must be taken out of service.

6.2 Understanding the LED Readout



6.2.1 Seven-Segment Display

The three-digit, seven-segment LED display indicates either the azimuth (horizontal level) or the glide slope (vertical) angle measured from the horizon. The angle is displayed on the LEDs as follows:

Display Value	Description
0.00 to 9.99	<ul style="list-style-type: none">Displays degrees of glide slope if push button SW1 (Glide/Azimuth) is not pushedDisplays degrees of azimuth (horizontal level) if push button SW1 (Glide/Azimuth) is pushed.
ON	<ul style="list-style-type: none">Normal operation (systems shipped after February 2011)
CLd	<ul style="list-style-type: none">Inclinometer is warming up (Initially on 15 seconds - 3 minutes for systems shipped after February 2011)
LEL	<ul style="list-style-type: none">Indicates you are adjusting/reading the Level (Horizontal/Azimuth).
gLI	<ul style="list-style-type: none">Indicated you are adjusting/reading the GLIDE (or vertical) angle.
LO	<ul style="list-style-type: none">Indicates glide slope is negative (PAPI aimed toward the ground).
HI	<ul style="list-style-type: none">Indicates glide slope is greater than 9.99 degrees from horizon.
EEE	<ul style="list-style-type: none">Shutdown due to external tilt signal from another PAPI.
CAL	<ul style="list-style-type: none">Indicates the glide slope (vertical) angle is being stored in memory.

Notes

¹ During alignment for 15 minutes, systems shipped after February 2011



Note

It takes 15 seconds for the display to warm up in cold weather.



Note

ICAO PAPI systems do not require tilt/detection shutdown, but may optionally be supplied if desired. A version of the system can be supplied without the tilt detection but with the digital display.

6.2.2 Push Button Functions

The SW1 and SW2 push buttons determine the display as follows:

SW1—Glide/Azimuth

SW1—Glide/Azimuth, there are 3 modes of display as follows:

- Push SW1 one time, display will momentary show 'LEL' and then display the horizontal or Azimuth angle until SW1 is pushed again.
- Push SW1 one more time, display will toggle back and forth between the glide angle and the Vertical Glide angle until SW1 is pushed again.
- Push SW1 one more time, display will momentary show 'gLI' and then display the glide angle until pushed again.

SW2—Set Angle

The SW2 push button stores the **glide angle** that defines proper vertical alignment for the PAPI Light Unit. If any PAPI Light Unit is raised more than $\frac{1}{2}$ degree or lowered more than $\frac{1}{4}$ degree from this angle, the inclinometer circuitry will de-energize all PAPI Light Unit lamps.

- Push and hold the SW2 push button for about 5 seconds until the letters CAL are displayed on the three-digit, seven-segment display for the Control Board to memorize the glide angle.

6.3 Initial Startup Using Local Control (Style A)

To turn ON the Style A PAPI system using local control:

1. See Note 1 in the drawing in [Figure 18](#). On the Power Control Unit (PCU) CCT Control Board, verify that switch S4-1 is set to OFF and that S4-2 to 5 is set to ON. Also, verify that jumper J9 is set to the three-step setting. See [Figure 18](#) (J9) for an example.
2. Turn circuit breaker CB1 to OFF and set Switch S1 to LOCAL.
3. Place a jumper across the output of the PCU at TB1-13 to TB1-14 using 10 AWG/600V wire, minimum. Using a true RMS amp meter, connect a current clamp around this wire.
4. Remove the photocell. This will force the PAPI to activate at 100%. Turn circuit breaker CB1 to ON. The true-RMS ammeter should read 6.6 amps.

- See [Figure 18](#) . If the reading is not 6.6 A, adjust the output current with buttons S1 “increase” (INC) and S2 “decrease” (DEC) on the CCT Control Board until the correct current is obtained. Press and hold the SAVE button for two seconds to save the setting. The Green SAVE LED D35 will turn ON when the reading is memorized by the CCT Control Board.

Figure 18: CCT Control Board

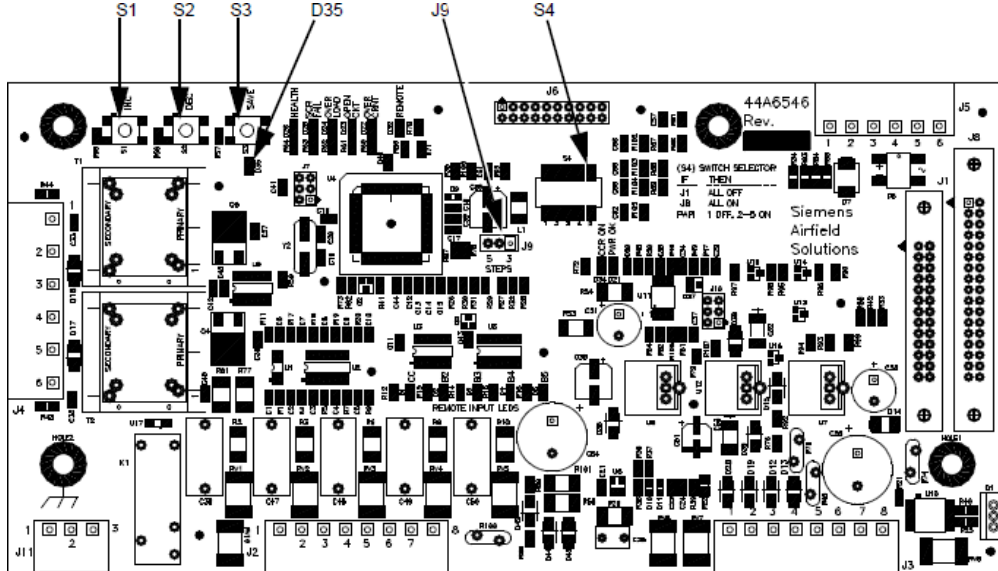

- Turn circuit breaker CB1 to OFF.
- Re-install the photocell and remove relay K2. This will force the PAPI to activate at either 5% or 20%.
- Turn CB1 to ON.
- Set Switch S2 to 20%. The true RMS amp meter should read 5.08A (see [Table 7](#)). If the reading is not 5.08A, adjust the output current with buttons INC and DEC on the CCT Control Board until the correct current is obtained. Press and hold the SAVE button for two seconds to save the setting. The Green SAVE LED D35 will turn ON when the reading is memorized by the CCT Control Board.

Table 7: Output Current

Intensity	Output Current
100%	6.6 A
20%	5.08 A
5%	4.09 A

- Set Switch S2 to 5%. The true RMS amp meter should read 4.09A (see [Table 7](#)). If the reading is not 4.09A, adjust the output current with buttons INC and DEC on the CCT Control Board until the correct current is obtained. Press and hold the SAVE button for two seconds to save the setting. The Green SAVE LED D35 will turn ON when the reading is memorized by the CCT Control Board.
- Turn circuit breaker CB1 to OFF.15. Reinstall relay K2, then select the desired intensity for nighttime operation by turning Switch S2 to 5% or 20%.
- Remove the wire between TB1-13 and TB1-14 and reapply the field load.
- Ensure that all Light Units are aligned properly and that the glide angle settings are memorized in each Light Unit. See [Align the PAPI](#) for the Light Unit setting procedure.
- Turn CB1 to ON and Switch S1 to LOCAL. The system should energize and all lamps should turn on.
- With the load applied, verify the current levels are correct at the output of the PCU by connecting a true RMS amp meter to either of the output wires. Readjust the CCT Control Board, if necessary.
- Verify that the current levels are correct inside each Light Unit. To check this:
 - Turn circuit breaker CB1 in the PCU to OFF.
 - Remove the lid from the closest secondary Light Unit.

- Connect a true RMS amp meter current clamp around one of the wires connected to one of the lamps.



Note

The three lamps are connected in series.

- Turn circuit breaker CB1 in the PCU to ON.
- Verify that the current is correct in each of the current steps. Troubleshoot or repair the external wiring if the current is incorrect.
- Repeat for each remaining Light Unit.

6.4 Set Up and Test Remote Control Operation

To set up and test remote control operation:

1. Turn circuit breaker CB1 to OFF.
2. Set Switch S1 to REM and connect remote control wiring to TB1-7 and TB1-8.
Disconnect the photocell.
3. Turn circuit breaker CB1 to ON. The system should energize and the true RMS amp meter should read 6.6 A. All lamps should illuminate.
4. Turn circuit breaker CB1 to OFF. Reinstall the photocell and remove relay K2. Set Switch S2 to the desired nighttime intensity setting (5% or 20%).
5. Turn circuit breaker CB1 to ON. The system should energize and all lamps should come on. The true RMS amp meter reading should correspond to the setting of Switch S2 (see [Table 7](#)).
6. Turn circuit breaker CB1 to OFF and reinstall relay K2.
7. The PAPI system is now ready for operation.

6.5 Set Up and Test Optional Interlock Relay

To set up and test the operation of the interlock relay (if present):

1. Ensure that the primary of a low-wattage isolation transformer is connected to the series circuit. Ensure that the secondary is connected to TB1-15 and TB1-16. A 6.6A secondary, 30/45W isolation transformer is typically used. However, a 10/15W or 20/25W isolation transformer may be used.
2. Set Switch S1 to REM and circuit breaker CB1 to OFF. Remove relay K2.
3. CS1 has the following activation ranges:
 - No jumper: 1 to 6 A
 - Mid jumper: 6 to 40 A
 - High: 40 to 200 A

Ensure that no jumper is used on CS1.
4. Turn circuit breaker CB1 to ON. The unit should remain off.
5. Turn on the CCR that controls the interlock relay. The unit should turn on and all PAPI Light Unit lamps should illuminate. The true RMS amp meter reading should correspond to the selected Switch S2 setting (see Step 12 in [Initial Startup Using Local Control \(Style A\)](#)).
6. Turn off the CCR. All Light Units should turn off.
7. Turn circuit breaker CB1 to OFF and reinstall relay K2.
8. Turn circuit breaker CB1 to ON.

6.6 Adjusting the Over Current Detection Level



Note

The Over Current setting is pre-set and normally does not need to be adjusted.

Before adjusting the Over Current detection level, insure the output current levels are adjusted per the instructions above. To adjust the overcurrent, perform the following procedure:

- Turn circuit breaker CB1 to OFF and set Switch S1 to LOCAL.
 - To ensure that the Light Unit lamps cannot be damaged by an over current situation during the adjustment, place a jumper across the output of the Power Control Unit (PCU) at TB1-13 to TB-14 using 10 AWG/600V wire, minimum. Using a true RMS amp meter, connect a current clamp around this wire.
 - Remove the photocell. This will force the PAPI to activate at 100%. Turn circuit breaker CB1 to ON. The true-RMS ammeter should read 6.6 amps.
 - Press and hold for three seconds both the INC and DEC buttons on the CCT Control Board. The Green LED D35, next to the SAVE button, will illuminate to indicated that you are in the Over Current Adjustment Mode.
-



Note

The CCR output current will increase to the level previously set as the Over Current level. This will be above 6.6 amps.

- Press the INC or DEC buttons until you reach the desired Over Current detection level.
 - Press and hold the SAVE button for two seconds. The SAVE LED will briefly turn off and then back on to indicate the reading is memorized by the CCT Control Board. Also, the CCR output will then go back to the top step setting (6.6 A).
 - Turn circuit breaker CB1 to OFF, re-insert the photocell, remove the short from the PAPI output and re-apply the field load.
-

6.7 Initial Startup of the Style B System

Each Light Unit is automatically energized when the constant current regulator (CCR) is activated, assuming that no Light Unit is in a tilt situation.

6.7.1 Check Light Unit Alignment

Ensure that all Light Units are aligned properly and that the glide angle settings are memorized in each Light Unit. See [Align the PAPI](#) for the Light Unit setting procedure.

6.7.2 Verify Correct Input Current in Each Light Unit

Verify that the input current from the series circuit is correct in each of the Light Units. To check this, perform these steps for each Light Unit:

- Turn the CCR OFF.
 - Remove the lid from the Light Unit closest to the input side of the series circuit.
 - Connect a true RMS amp meter current clamp around one of the wires connected to one of the lamps.
-



Note

The three lamps are connected in series.

- Turn the CCR ON to the lowest step (2.8A for a three-step CCR or 4.8A for a five-step CCR). Verify that the current is correct.
 - Verify that the current is correct in each of the remaining current steps.
Troubleshoot or repair the external wiring if the current is incorrect.
-

6.8 Commissioning the PAPI System

After the PAPI system setup is complete, perform a flight check prior to commissioning the system.

7.0 Maintenance

This section provides maintenance information and procedures for L-880 and L-881 PAPI systems.

7.1 Maintenance and Repair Safety Considerations



WARNING

Allow only qualified personnel to perform maintenance, troubleshooting and repair tasks. Only persons who are properly trained and familiar with ADB SAFEGATE equipment are permitted to service this equipment.

- Always use safety devices when working on this equipment.
- Follow the maintenance procedures recommended in equipment manuals.
- Do not service or adjust any equipment unless another person trained in First Aid and CPR is present.
- Connect all disconnected equipment ground cables and wires after servicing equipment. Ground all conductive equipment.
- Use only approved ADB SAFEGATE replacement parts. Using unapproved parts or making unapproved modifications to equipment may void agency approvals and create safety hazards.
- Check CCR interlock systems periodically to ensure their effectiveness.
- Do not attempt to service electrical equipment if standing water is present. Use caution when servicing electrical equipment in a high- humidity environment.
- Use tools with insulated handles when working with electrical equipment.
- Also review and follow safety guidelines in FAA AC 150/5340-26 (current edition), Maintenance of Airport Visual Aid Facilities.

7.2 Maintenance Schedule

To keep the PAPI unit operating efficiently, follow the preventive maintenance schedule in [Table 8](#) .

Table 8: Single-Channel PAPI Maintenance

Interval	Maintenance Task	Action
After installation and Before operational use	Make flight check of system.	Readjust if needed.
After installation (first few weeks)	Check elevation angle of Light Units using the onboard inclinometer.	Readjust if needed. Refer to Additional Siting Considerations for Light Unit alignment. To independently check the elevation aiming angle, refer to Checking Slope Angles of PAPI Unit .
Daily	If Light Units are not operated continuously, check for frost or dew on the outer lens.	Remove frost or dew and check airport lighting circuitry per CertAlert 02-08 (see "FAA CertAlert on PAPI Operation").
	Check to ensure all lamps are illuminating and illuminated evenly.	Replace burned-out lamps. Clean any dirty lenses and shields.
	Visually check for any apparent evidence of damage to the Primary (Style A systems) or any Light Unit.	Repair or replace any damaged components.

Table 8: Single-Channel PAPI Maintenance (Continued)

Interval	Maintenance Task	Action
Monthly	Check all control equipment—including photocell (Style A systems)—for proper operation.	Repair or replace any damaged components.
	Clean the outer surface of the protective glass.	Use a soft cotton cloth moistened with alcohol.
	Check the glide slope and azimuth angle of each Light Unit.	Use the onboard Light Unit digital readout. Readjust if necessary.
	Inspect housing and closure system, lamps, electrical connections, filters and protective glass for damage, breakage or warpage.	Repair or replace any damaged parts.
	Clean the interior of the housing.	Remove any foreign matter. Also check for water damage, insect infestation and presence of rodents. Clean both sides of the protective glass, color filters, lenses and reflectors. Use a soft cotton cloth moistened with alcohol.
	Make sure mounting is rigid.	Tighten any loose hardware—nuts, screws, etc. Realign the Light Unit if hardware has loosened.
	Make sure no vegetation obscures the light beams.	Remove vegetation. Use weed killer to prevent any regrowth.
	Check whether the lightning arresters and/or surge suppressors are scorched or show other signs of failure. Also check after electrical storms.	Replace as necessary.
Quarterly	Record true RMS input current to each Light Unit and input voltage to Primary (Style A systems).	Repair or replace equipment if input is abnormal.
	Ensure fan is operating and exhausting air from the PAPI enclosure.	Replace fan if not operational.
Quarterly	Check the obstacle-free approach plane for clearance from tree growth, new towers, pole lines or other obstacles. The obstacle-free plane is four miles long and extends 10 degrees on either side of the runway centerline.	Remove obstacles as necessary.
Semiannually	Check the insulation resistance of underground cables and record the results. Check the resistance of the grounding system and record the results.	Repair or replace as necessary. Repair or replace as necessary.

7.3 Standards and Tolerances

Table 9: Precision Approach Path Indicator (PAPI) Standards and Tolerances

Parameter	Standard	Tolerance / Limit	
		Initial	Operating
Lamps burning			
<ul style="list-style-type: none"> PAPI 	All	All	No more than two lamps out per Light Unit
Vertical aiming			
<ul style="list-style-type: none"> Unit second from runway 	3° 10'	±2' (0.03°)	±6' (0.1°)
<ul style="list-style-type: none"> Unit third from runway 	2° 50'	±2' (0.03°)	±6' (0.1°)
<ul style="list-style-type: none"> Unit farthest from runway 	2° 30'	±2' (0.03°)	±6' (0.1°)
Horizontal alignment	Parallel to runway centerline	±2' (0.03°)	±30' (1/2°)

Table 9: Precision Approach Path Indicator (PAPI) Standards and Tolerances (Continued)

Parameter	Standard	Tolerance / Limit	
		Initial	Operating
Tilt Detection	0.25° degree below to 0.50° degree above established Light Unit angle	Same as standard	
Lamp current (current-regulated)	Rated current of lamps	See AC 150/5345-10 (current edition) for CCR output current tolerances.	
Obstructions due to vegetation, etc	No obstruction	Same as standard	

Notes

¹ Unless a different standard is established locally, angles shown are for a 3-degree glide path.

7.4 Maintenance Procedures

7.4.1 Replacing a Lamp

All lamps should be replaced after a service period of approximately 800 hours at the 100% brightness level. For a Style B system, an elapsed-time recorder connected to the constant current regulator may be used to determine the time for replacement.



CAUTION

Wear cotton gloves when handling the lamps. Touching the quartz bulb with bare fingers may seriously shorten lamp life. If the quartz bulb has been touched, wipe it carefully with lens cleaning tissue or similar material moistened with isopropyl alcohol.

To replace a lamp:

1. Depending on the type of PAPI:
 - **Style A:** De-energize the main input power breaker. Turn off circuit breaker CB1.
 - **Style B:** Turn off and lock out the CCR that powers the PAPI system.
2. Remove the cover from the Light Unit.
3. Disconnect the electrical slip-on fitting from the burned-out lamp.
4. Swing the spring-loaded fork back and remove the lamp.
5. Replace the lamp and reverse steps to complete installation. The lamp shorting circuit is automatically reset when power is restored.

7.4.2 Replacing Objective Lenses

Never attempt to replace an objective lens. Objective lenses are precisely positioned in the Light Unit and are not field-repairable because the optical center of the lens must be realigned after replacement.

If an objective lens is damaged, return the PAPI Light Unit to the factory for repair and adjustment. Contact the ADB SAFEGATE Sales Department for details.

7.4.3 Replacing the Red Filter

The red filter must be perfectly clean. Use a soft cotton cloth moistened with alcohol to clean the filter. Wear cotton gloves when handling a filter.

The filter is held in place in the filter holder by a filter-retaining spring.



Note

When cleaning filters in multiple units, make sure each filter is returned to the same filter holder from which it was removed.

To remove or replace a filter:

1. Remove the filter-retaining spring.
2. Remove the filter by sliding it upward out of the holder.
3. To reinstall the filter, reverse the removal steps. The filter must be installed in the holder so that the lower edge (dull edge) of the filter is down. The top edge has 0.08" x 45° bevels on each corner.

7.4.4 Replacing an Inclinometer PCB Assembly

Refer to the drawings in [Maintenance](#) when performing these steps:

Note
Inclinometer 44A6813 (RevE or earlier) or 44A6813/INSL is replaced by 44A6813 (RevF or later).

Note
Upon initial replacement of either of the older PAPI Control Boards 44A6674 or 44A6674-1 or the inclinometer PCB assembly 44A6813 (RevE or earlier), you must replace both items with new PAPI control boards 44A7122 or 44A7122-1 and 44A6813 (RevF or later).

1. Remove three (3) #8-32 x 3/8 pan head Phillips screws attaching the 44A6813 inclinometer PCB assembly to the 60A3325 Mounting Plate.

Note
Do not attempt to remove the 1/4-28 x 1 socket cap screws attaching the 60A3325 Mounting Plate to the enclosure bottom plate.

2. Install new 44A6813 inclinometer PCB Assembly and replace the three (3) #8-32 x 3/8 pan head Phillips screws.

7.4.5 Checking Slope Angles of PAPI Unit

It may be requested that when the equipment is put initially into operation and at regular intervals thereafter, the cut-off angle of the Light Units be checked. To make this measurement, it will be necessary to use a surveying instrument or a bubble level with telescope and a surveyor's stake.

To check the slope angles of the PAPI Light Units, perform the following procedure:

1. See [Figure 19](#) . Place the surveying instrument 6 to 10 feet (1.83 to 3.05 m) behind the Light Unit pointing down beam.

Figure 19: Checking Slope Angles

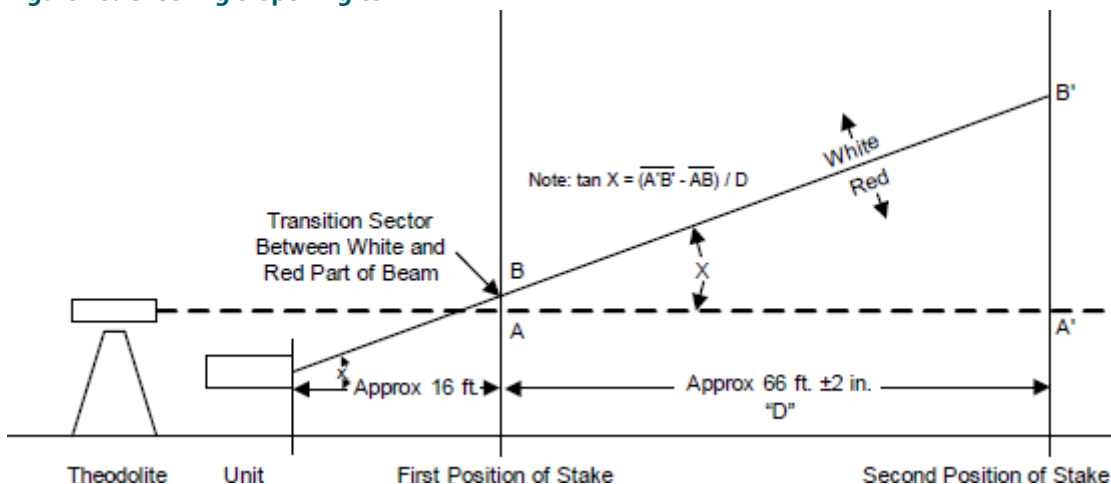

2. A surveyor's stake is held by an assistant approximately 16 feet (4.88 m) in front of the Light Unit.
3. Take reading A for the intersection of the horizontal of the telescope with the stake.

-
4. Take reading B for the intersection of the cut-off plane of the light beam with the surveyor's stake.
 5. The assistant should now move a precisely measured distance of about 66 feet (20 m) $\pm 0.25\%$ down beam and take the same measurements A' and B', as in Steps 3 and 4 above.
 6. The angle x of the beam cut-off to the horizontal is found from the following formula:

$$\tan x = (\overline{A'B'} - \overline{AB}) / D$$



Note

The overline (—) denotes length where D is the horizontal distance between the two stake positions.

If similar checks are to be scheduled in the future, a small concrete pad holding a galvanized pipe may be installed in front of each Light Unit at the distances used above.

8.0 Field Installation of Adjustable PAPI Baffles

8.1 Introduction

This service bulletin provides instructions for modifying the horizontal light beam coverage of the PAPI unit for obstacle avoidance in the approach area for the ADB SAFEGATE' 1-lamp Single Channel PAPI.

8.1.1 References

Refer to [Table 10](#) for references.

Table 10: References

Reference Description	ADB SAFEGATE's Part Number
USER MANUAL	96A0379
SPARE PARTS MANUAL	SP_2082
DATA SHEET	DS-2082
INSTALLATION DRAWINGS	117A0039 117A0047
WIRING SCHEMATICS	43A3377 (Style A) 43A3390 (Style B) 43A3292 - Power Control Unit 43A3282 - Connection

8.1.2 Special Tools and Equipment Required

Refer to [Table 11](#) for the special tools and equipment. This equipment is not supplied.

Table 11: Required Equipment Not Supplied

Description	Quantity
Walkie-talkies or other form of communication	2
Small Phillips screwdriver	1
Combination square or machinist's square	1
Instruction manual for PAPI <i>part number 96A0379</i>	1

8.1.3 Items Included in PAPI Baffle Retrofit Kits

This subsection provides the PAPI Baffle Retrofit Kit ordering code, and a parts list for 2-box and 4-box baffle kits.

8.1.4 PAPI Baffle Retrofit Kit Ordering Code

See [Figure 2](#) to determine the part number for a particular PAPI Baffle Retrofit Kit.

Single Channel PAPI Baffle Kit 94A0570 /

Type

2 = L-881 (2 Box)

4 = L-880 (4 Box)

Primary Obstruction Cut-Off (Left or Right Side)

1 = 0.0 to 3.3 Degrees

2 = 3.1 to 6.4 Degrees

3 = 6.3 to 10.0 Degrees

Secondary Obstruction Cut-Off

0 = No Secondary Obstruction

1 = 0.0 to 3.3 Degrees

2 = 3.1 to 6.4 Degrees

3 = 6.3 to 10.0 Degrees

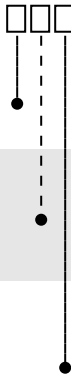

Notes

- The Single Channel PAPI Baffle allows airports to modify the horizontal light beam coverage of the PAPI unit for obstacle avoidance in the approach area. See Service Bulletin ALN152 for field installation details.
- Cut-Off angle is the amount of light reduced from a full width beam of 10 degrees. Kit includes baffles for all light units.
- Baffles are interchangeable and can be installed to obstruct PAPI light on either LEFT or RIGHT side.

Note

The SC PAPI Baffle allows airports to modify the horizontal light beam coverage of the PAPI unit for obstacle avoidance in the approach area. See Service Bulletin ALN152 for field installation details.

8.1.5 Baffle Kit Parts List

Refer to [Table 12](#) for the Baffle Kit parts list.

Table 12: Baffle Kit 94A0570-XXX, Parts per Unit

	Part Number	One Obstruction	Two Obstructions
Baffle Mounting Plate	60C1672	1	1
Baffle (0.0 -3.3) Cut-Off	60B1673-1	1	2
Baffle (3.1 – 6.4) Cut-Off	60B1673-2	1	2
Baffle (6.3 – 10) Cut-Off	60B1673-3	1	2
Pan head screws, 6-32 x 0.75 long	64A0198-12	2	4
Lockwasher, Split #6	66A0026-11	2	4
Hex Nut, 6-32	65A0015-11	2	4
Pan head screws, 8-32 x 0.38 long	64A0966/06	2	4

8.2 Modification Procedure



Note

One baffle is required for EACH PAPI Light Box. Each set of baffles are to be the same cut-off range. More than one baffle type (cut-off range) can be ordered depending upon the application. Contact ADB SAFEGATE if you are not sure about the cut-offs required for your particular application.

The estimated time required is 60 minutes per PAPI Light Box.



CAUTION

Only personnel authorized to work on high voltage equipment should make the modifications described in this service bulletin.



CAUTION

Disconnect equipment from line voltage. Failure to observe this warning may result in personal injury, death, or equipment damage.



Note

Coordinate a power outage for the PAPI system with Air Traffic personnel.

To modify the horizontal light beam coverage of the PAPI unit, perform the following procedure:

1. De-energize the PAPI system.

Depending on the location of the obstruction in the approach area (right or left side), attach the baffle mounting plate on the back side of the enclosure filter bracket.

Figure 20: Single Channel PAPI Box Assembly

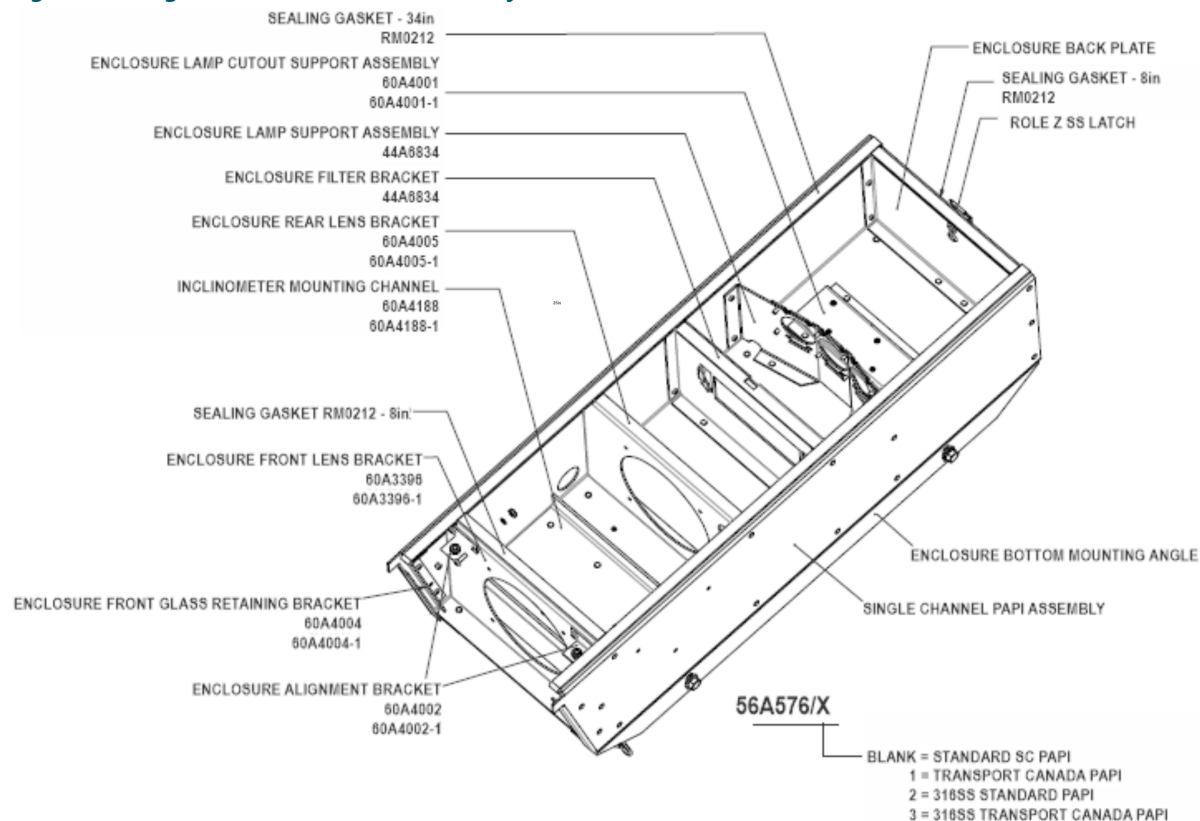



Note

The baffle mounting plate is mounted on either the left or right side of the enclosure filter bracket by flipping the plate over.

2. Fasten the Baffle Mounting Plate to the enclosure filter bracket by using the #6-32 x 0.75 long pan head screws, hex nuts, and split lock washers provided.
3. Insert the #6 screws through the plate and the mating slots in the enclosure filter bracket located at the end of the filter slot.

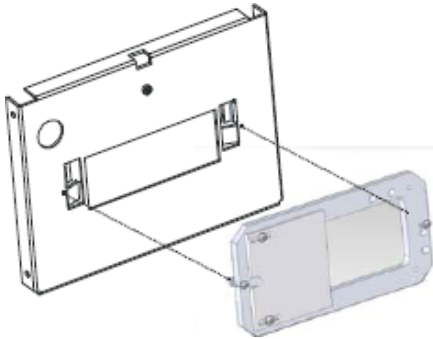

4. IF the obstacle is on the LEFT side of the approach area, then install the baffle over the filter slot on the RIGHT side. See [Figure 21](#). **-OR-**
IF the obstacle is on the RIGHT side of the approach area, then install the baffle over the filter slot on the LEFT side. See [Figure 22](#).

Figure 21: Baffle Located on Right Side of Enclosure Filter Bracket for Obstacle Located on Left Side

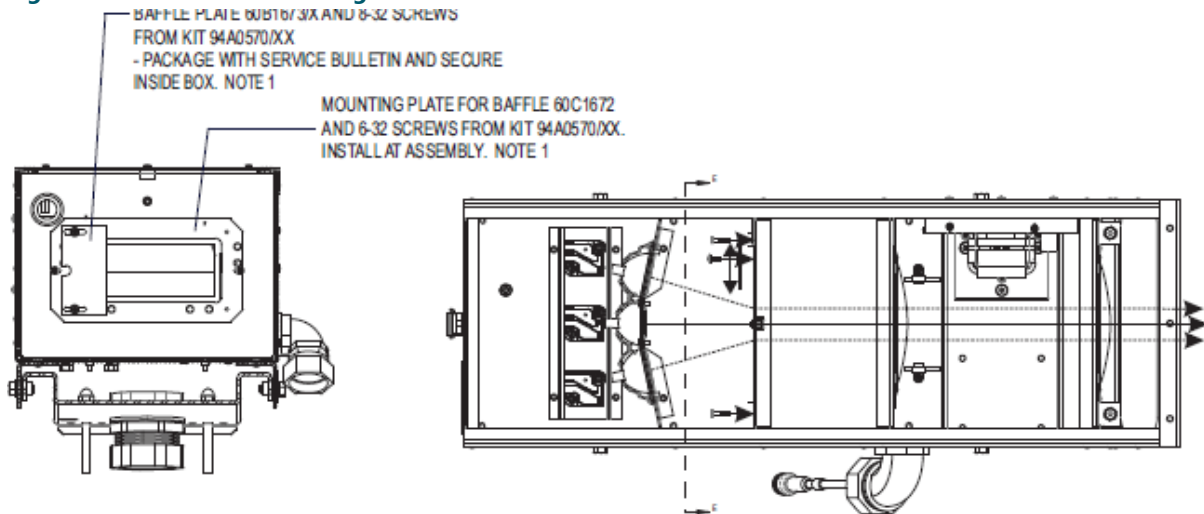
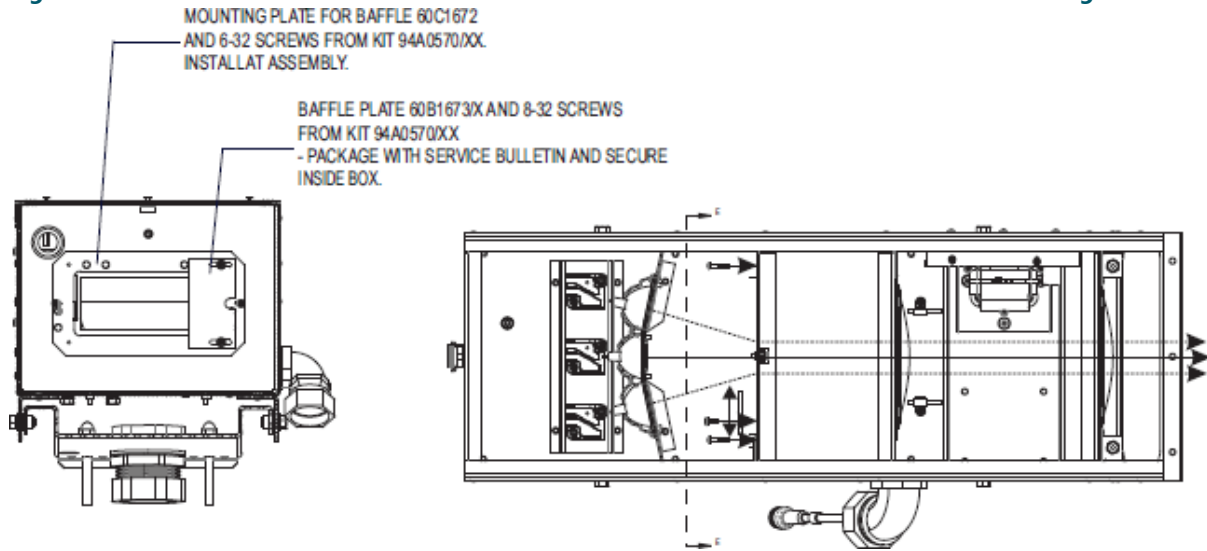

Figure 22: Baffle Located on Left Side of Enclosure Filter Bracket for Obstacle Located on the Right Side



Note

If both sides are obstructed, complete one side at a time.

Figure 23: PAPI Signal Viewing Zone

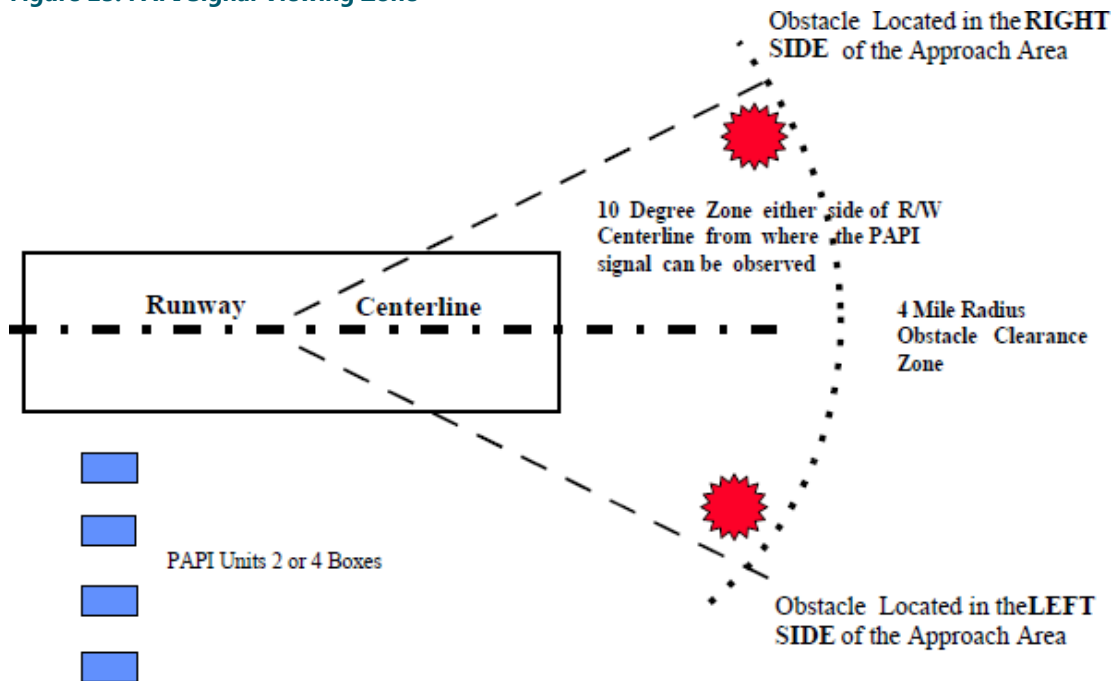

5. Take a combination square or machinists' square of appropriate length, and square the Baffle Mounting Plate with the top edge of the filter Enclosure Filter Bracket. See [Figure 24](#).

Figure 24: Squaring Top Edge of Baffle Mounting Plate
Baffle Mounting Plate Screws

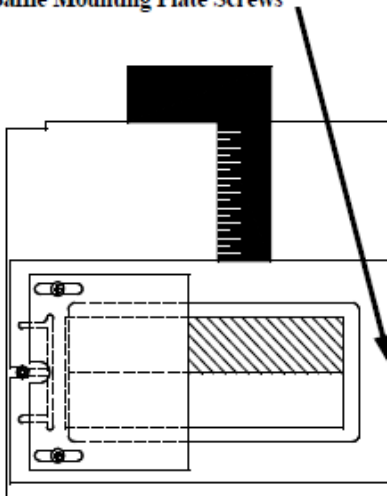

6. Using the #10-32 x 0.38 large screws, and hex nuts supplied with the baffle, install baffle as required for the application. Two #10-32 tapped holes are located in the Baffle Mounting Plate.



Note

Until the cutoff has been confirmed, the two screws should only be finger tight.

7. Apply power to the lamp.



Note

It may be necessary to lower the PAPI unit in elevation for the individual to see the light beam. See manual 96A0379 for any required alignment adjustment.

8. Position someone equipped with a walkie-talkie at the edge of the obstacle or as far out from the edge the beam where cutoff is desired. Move the baffle along the aperture of the baffle mounting plate until the light beam cut-off is seen by the individual who is standing in front of the obstacle. Use a combination square to make sure the machined edge on the baffle is perpendicular to the top edge of the Baffle Mounting Plate. Tighten the two screws on the baffle. See [Figure 25](#).

Figure 25: Squaring Baffle Plate with Top Edge of Baffle Mounting Plate

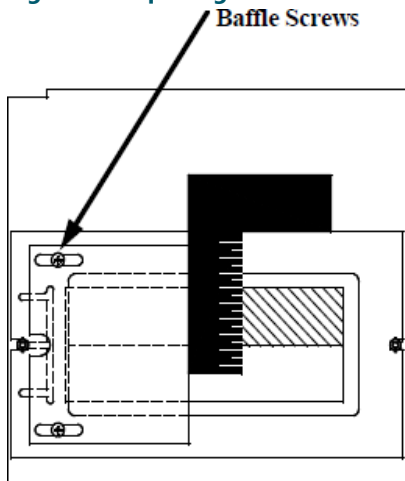

9. Energize the lamp in the PAPI unit, and verify that the light beam cannot be seen by the individual stationed at the obstacle. If the light beam is visible, repeat Step 8.

-
10. Disconnect power from the PAPI unit, remove the jumper from tilt switch (if installed), and reinstall the red filter. The red filter's **ground edge must be installed facing down** . If the filter is dirty, use a soft cotton cloth moistened with alcohol to clean the filter.
 After the filter has been reinstalled, recheck the cutoff to make sure it is correct for each PAPI Light Box. If the settings are correct, remove ONE SCREW AT A TIME AND PLACE A DROP OF LOCTITE 242, or equal, thread locking compound on the threads. Retighten the screws. Repeat this process for each screw used to secure the baffle.
 11. Repeat Steps 1 through 13 for the remaining PAPI units in the system. The individual observing the horizontal cutoff for the PAPI units should remain at the same position for all observations.
 12. If the PAPI units were lowered in elevation, the units will require realignment and the tilt switches will need to be leveled. Consult the subsection *Aligning Units* in the *Installation* sections of instruction manual 96A0379 for instructions to align the PAPI and level the tilt switches.
 Before putting the PAPI system into service, a flight check of the PAPI system is required to determine if all horizontal cutoffs of the PAPI beams are properly located relative to the obstacle(s).
 13. **After the cut-off angle has been verified, remove jumpers** from the Tilt Switch by reversing the procedure as outlined in Step 8. In addition, see instruction manual 96A0379 to verify that the Tilt Switch is wired correctly **BEFORE PLACING PAPI IN SERVICE** .
-



Note

These adjustable baffles have been designed to be used in ADB SAFEGATE' PAPI light boxes to alter the horizontal cut-off angle avoidance of obstacles. The customer is responsible for the proper installation and verification that the horizontal cutoff produced by the baffles meets the requirements set by the FAA for obstacle avoidance. Therefore ADB SAFEGATE asserts that it be held harmless for the end use of the ADB SAFEGATE PAPI in this special baffle application.

9.0 Troubleshooting and Repair



WARNING

Allow only qualified personnel to perform the following tasks. Observe and follow the safety instructions in this document and all related documentation.

Before attempting to service the fixture, de-energize the circuit and lock out the circuit or regulator so that the circuit cannot be energized by remote means.

9.1 Troubleshooting Tips

Refer to [Figure 26](#) for general troubleshooting procedures. This guide covers only the most common problems. The following paragraphs provide specific details on troubleshooting and repair of PAPI subsystem components. For additional help, contact your local ADB SAFEGATE representative.

Table 13: General PAPI System Troubleshooting Guide

Problem	Possible Cause	Solution
All lamps out	PAPI Light Unit tilt.	Realign PAPI Light Unit(s) that have tilted.
	Style A: No power input or Power Control Unit (PCU) failed.	Style A: See troubleshooting procedure in Troubleshooting and Repairing the Power Control Unit (Style A Only) . Style B: No input from series circuit. Repair CCR or series circuit wiring (if an open circuit is present on the series circuit).
	All lamps failed.	Replace lamps. Verify current level into Light Units is correct. Recalibrate CCT Control Board (Style A) or CCR (Style B) if necessary.
	Style A: CCT Control Board in Power Control Unit (PCU) failed.	Replace CCT Control Board. Calibrate board after replacement. See troubleshooting procedure in Troubleshooting and Repairing the Power Control Unit (Style A Only) .
	Style A: SCRs failed.	Replace SCRs. See troubleshooting procedure in Troubleshooting and Repairing the Power Control Unit (Style A Only) .
Lamp(s) dim	Style A: CCT Control Board has detected an open circuit or overcurrent in the output series circuit.	See troubleshooting procedure in Troubleshooting and Repairing the Power Control Unit (Style A Only) .
	Dirty lens shield.	Clean with a soft cotton cloth moistened with alcohol.
	Lamp not properly seated in reflector.	Re-seat lamp in the lampholder.
	Current level too low.	Style A: Recalibrate CCT Control Board, if necessary. See calibration procedure in Initial Startup Using Local Control (Style A) . Style B: Low input current from series circuit. Repair CCR or series circuit wiring (if an open circuit is present on the series circuit).
	Red filter broken.	Replace if necessary. See Red Filter Replacement .
	Lens improperly aligned.	Replace lens if loose in ring.
Signal Interruption when PAPI unit is not operated continuously	Light Unit improperly aligned.	 Note To replace lens, Light Unit must be returned to factory.
		Realign and recalibrate Light Unit.
Signal Interruption when PAPI unit is not operated continuously	Frost or dew on outer lens.	Change airport circuitry to ensure PAPIs are preset to operate continuously on a low power setting of either 5% or 20%. See "FAA CertAlert on PAPI Operation".

Table 13: General PAPI System Troubleshooting Guide (Continued)

Problem	Possible Cause	Solution
Style A: Current sensing not operating	Current level too high.	Check true RMS current into lamps. Re-calibrate the CCT Control Board (Style A) or CCR (Style B) if necessary. See calibration procedure in Initial Startup Using Local Control (Style A) .
	CCR is OFF.	Turn CCR ON.
	Current sensing jumper not set properly.	Set current sensing jumper on CS1 in Power Control Unit. CS1 has the following activation ranges: <ul style="list-style-type: none"> No jumper: 1 to 6A; Mid jumper: 6-40A; High: 40-200A Ensure that no jumper is used on CS1.

9.2 Detailed Troubleshooting and Repair Procedures

This section describes procedures for troubleshooting or repairing parts in either the Style A Power Control Unit (PCU) or the Light Unit.

9.2.1 Troubleshooting and Repairing the Power Control Unit (Style A Only)

To troubleshoot and repair the Style A Power Control Unit, follow these steps:

1. Visually examine all areas of the Power Control Unit. Check for burnt or loose connections and parts.
2. Check all fuses and the circuit breaker. See [Table 14](#) .
3. If the PAPI does not energize at all, check for under-voltage. If an under-voltage exists, correct the under-voltage problem. The input voltage must be within +10% to -5% of nominal.
4. Verify that all LED indications on the CCT-Control PCB1 are correct. See [Figure 26](#) and [Table 14](#) .
5. Measure for the presence of correct voltages as detailed in [Power Control Unit \(PCU\)](#) . Correct/repair as needed.
6. Check whether a tilt situation has shut down all PAPI Light Units. You can verify this in the Primary by measuring the voltage at TB1-10 (TILT SWITCH +) to TB1-9 (TILT SWITCH COM). The voltage should be +8 to +12VDC if no Light Units are tilted and less than +2VDC if any Light Unit has tilted. The red **TILT** LED will be lit on the Light Unit that is the source of the trouble.
7. If the PAPI works in LOCAL but not in REMOTE, check the remote control command LED indications on CCT-Control PCB1 and, if suspected as a problem, the actual voltage on the remote control lines. Check fuse F3. If voltage on remote control lines is correct and fuse F3 is normal, replace the CCT-Control PCB1.
8. If the PAPI turns on for a few seconds and then shuts off, then either an open circuit or over-current may be present. Manually set circuit breaker CB1 to OFF momentarily and then to ON. If the system momentarily re-energizes and then shuts off again, and either the Red LED D23 "OPEN CKT" or the Red LED D22 "OVER CRNT" illuminates, this verifies the cause of the problem is likely an open circuit or over-current. Turn the PAPI OFF and short the PAPI Primary output with an AWG 10/600V (minimum) wire across TB1-13 and TB1-14. Turn ON the PAPI. If the PAPI operates normally, the problem is likely load- related. Using an ohmmeter, check the output wiring for continuity. Repair the PAPI output wire from the Power Control Unit output to the individual Light Unit, if needed. If the output wire is continuous with no opens, recalibrate the over-current setting on CCT-control PCB1. See "[Initial Startup Using Local Control \(Style A\)](#) . Reconnect the Light Units and re- energize the Power Control Unit. If this does not solve the problem, replace the CCT-Control PCB1. If

this does not solve the problem, replace the dual SCR block. If this does not solve the problem, check all wiring connected to current transformer T2. If OK, replace T2.

Table 14: Style A Primary Panel Protection Devices

Device	Designation	Value	Function
Circuit Breaker	CB1	15A	Incoming power protection
Fuse	F1	2A, Slow Blow	Transformer T3 and Auxiliary Power output protection
Fuse	F2	2A, Slow Blow	Transformer T3 and Auxiliary Power output protection
Fuse	F3	0.25A, Slow Blow	Remote and Local signal protection
Fuse	F4	1A, Slow Blow	Contactors K1 protection

9.2.2 CCT-Control PCB1 Replacement in Power Control Unit (PCU)

If a problem is suspected with the CCT-Control PCB1, check the following LED indications:

Table 15: CCT-Control PCB1 LED Indications

Description	Reference	Indication	Note
CC	D1	Green	If ON, either a remote or local command has been input into the board to turn the PAPI ON. If OFF, neither a remote nor local command has been input into the board to turn the PAPI ON.
B2	D2	Green	For PAPI applications, this LED is always OFF.
B3	D3	Green	If ON, either a remote or local command has been input into the board to turn the PAPI ON to the 5% setting. If OFF, neither a remote nor local command has been input into the board to turn the PAPI ON to the 5% setting.
B4	D4	Green	If ON, either a remote or local command has been input into the board to turn the PAPI ON to the 20% setting. If OFF, neither a remote nor local command has been input into the board to turn the PAPI ON to the 20% setting.
B5	D5	Green	If ON, either a remote or local command has been input into the board to turn the PAPI ON to the 100% setting. If OFF, neither a remote nor local command has been input into the board to turn the PAPI ON to the 100% setting.
PWR OK	D21	Green	If ON, input voltage is present and the internal unregulated DC power supply voltage is OK. If OFF, no input voltage is present on the board or the internal unregulated DC power supply voltage is not OK.
OVER CRNT	D22	Red	If ON, an over current has been detected on the Primary output series circuit wiring. If OFF, an over current has on the Primary output series circuit wiring has not been detected.
OPEN CKT	D23	Red	If ON, an open circuit has been detected on the Primary output series circuit wiring. If OFF, an open circuit has on the Primary output series circuit wiring has not been detected.
OVERLOAD	D24	Red	If ON, an overload on the Primary output may be present. This can also be caused by shorts or other faults in the Primary output series circuit wiring. If OFF, an overload on the Primary output series circuit wiring has not been detected.
SCR FAIL	D25	Red	If ON, the microprocessor on the board has determined that either of the two SCRs (in the SCR block) is not operating correctly. If OFF, the microprocessor on the board has determined that either of the two SCRs (in the SCR block) is operating correctly.

Table 15: CCT-Control PCB1 LED Indications (Continued)

Description	Reference	Indication	Note
HEALTH	D26	Green	If ON, the microprocessor on the board is operating correctly. If OFF, the microprocessor on the board is not operating correctly.
REMOTE	D32	Green	For PAPI applications, this LED is always OFF.
CCR ON	D34	Green	If ON, no fault has been detected and the command to turn on contactor K2 (via J4-4 and 6) is activated. If OFF, a fault (open circuit or overcurrent) has been detected or the Primary has been switched OFF and contactor K2 is deactivated.
SAVE	D35	Green	This LED is normally OFF. It turns ON during various output current and over current setting procedures.

- To replace the CCT-Control PCB1, turn power OFF and remove all connectors and mounting screws.
- Replace with a new CCT-Control PCB1. Verify S4 and J9 are set to the correct positions. Calibrate the board according to the directions in [Initial Startup Using Local Control \(Style A\)](#).

9.3 Troubleshooting and Repairing the Light Unit

To troubleshoot and repair a PAPI Light Unit, follow these steps:

1. With the Light Unit powered, look in the front glass of the Light Unit.
2. Check the LED indications on the Control Board. See [Table 16](#).
3. Check the information on the display.
4. Depending on the information read on the Control Board, take corrective actions to repair the Light Unit. Details on further troubleshooting/repair are detailed in the paragraphs below.

Table 16: Light Unit Control Board LED Troubleshooting Guide

LED	Name	Description
D36	LAMP A OUT	Lighted (red) if Lamp A is burned out
D37	LAMP B OUT	Lighted (red) if Lamp B is burned out ¹
D38	LAMP C OUT	Lighted (red) if Lamp C is burned out ¹
D39	TILT LED	Lighted (red) if a tilt condition is detected
D40	Power ON	Lighted (green) if +5 VDC power is on

Notes

¹ If looking at the Light Unit from the front:

- Lamp A is on the right
- Lamp B is on the middle
- Lamp C is on the left

9.3.1 Light Unit Control Board Replacement



CAUTION

ELECTROSTATIC SENSITIVE DEVICES

This equipment may contain electrostatic sensitive devices.

- Protect from electrostatic discharge.
- Electronic modules and components should be touched only when this is unavoidable e.g. soldering, replacement.
- Before touching any component of the cabinet you should bring your body to the same potential as the cabinet by touching a conductive earthed part of the cabinet.
- Electronic modules or components must not be brought in contact with highly insulating materials such as plastic sheets, synthetic fiber clothing. They must be laid down on conductive surfaces.
- The tip of the soldering iron must be grounded.
- Electronic modules and components must be stored and transported in conductive packing.

Failure to follow this instruction can result in equipment damage.

If a problem is suspected with the Light Unit Control board, refer to drawings in [Schematics](#) and check the following indicators and test points.

Figure 26: Light Unit Control Board Indicators and Test Points

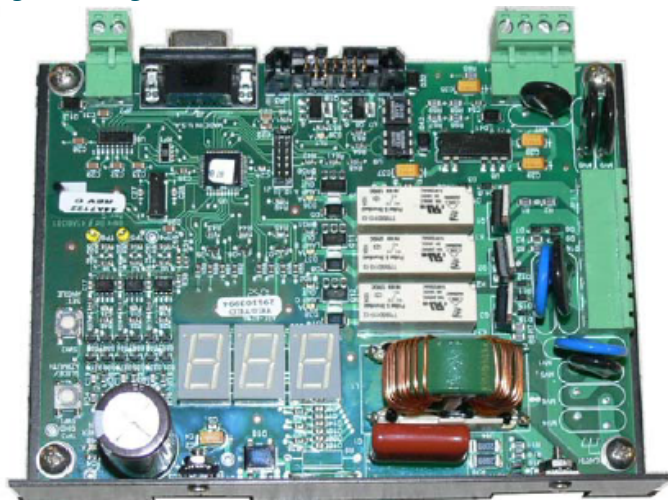

1. Power Supply LED

- Verify **D40** , the Power ON LED is lit (Green). If lit, this verifies that the on-board +5 VDC power is ON and operational.

2. DC Power Supply Measurements

- **TP1:** +5VDC power supply $\pm 0.25V$. Reference: **TP3** , Ground.
- **TP2:** This is the unregulated input DC voltage. It should be +12VDC $\pm 2V$. Reference: **TP3** , Ground.



Note

Test points TP4, TP5 and TP6 are not used.

3. Tilt Signal Voltage Measurements

- **JP4, Pin 1:** Red wire, tilt signal
- **OK:** +8 to +12VDC. Reference: **JP4, Pin 3:** Green wire, tilt signal return.
- **Light Unit Tilted:** < +2VDC. Reference: **JP4, Pin 3:** Green wire, tilt signal return.
 - To replace the Light Unit Control Board, turn power OFF and remove all connectors and mounting screws.
 - Replace with a new Light Unit Control Board.
 - Calibrate the Light Unit Control Board according to the procedure in [Initial Startup Using Local Control \(Style A\)](#) .

9.3.2 Light Unit Inclinometer Board Replacement



If a problem is suspected with the inclinometer board, first verify the following voltage is present on the board (refer to the figure at right):

- **TP1:** +5VDC \pm 5%. Reference: **TP2** , Ground (GND)
-



Note

Test points TP3 and TP4 are not used.

The inclinometer board is precision-mounted on the Light Unit. If this board needs to be replaced, contact the ADB sales department for details.

9.3.3 Red Filter Replacement

Before replacing the red filter, review the following precautions.



CAUTION

The red filter must be perfectly clean.

- Use a soft cotton cloth moistened with alcohol to clean the red filter.
- Wear cotton gloves when handling filters.

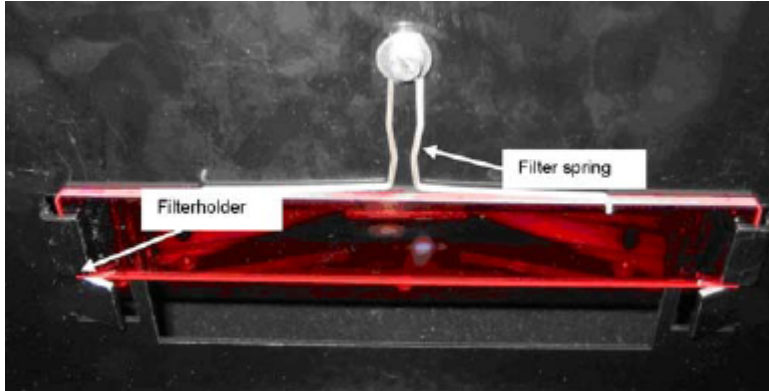

To replace a filter (see figure at right):

1. De-energize the circuit.
2. Open the Light Unit.
3. Unscrew the screw retaining the filter spring.
4. Lift the filter out of its holders.
5. Remove the broken filter.
6. Place a new filter in its holder with the side without the chamfer in the corners of the filter up.
7. Reverse this procedure.

9.4 Schematics

9.4.1 Drawings

Figure 27: External Wiring, Single Channel PAPI Style A, L-881 (2 Box) System

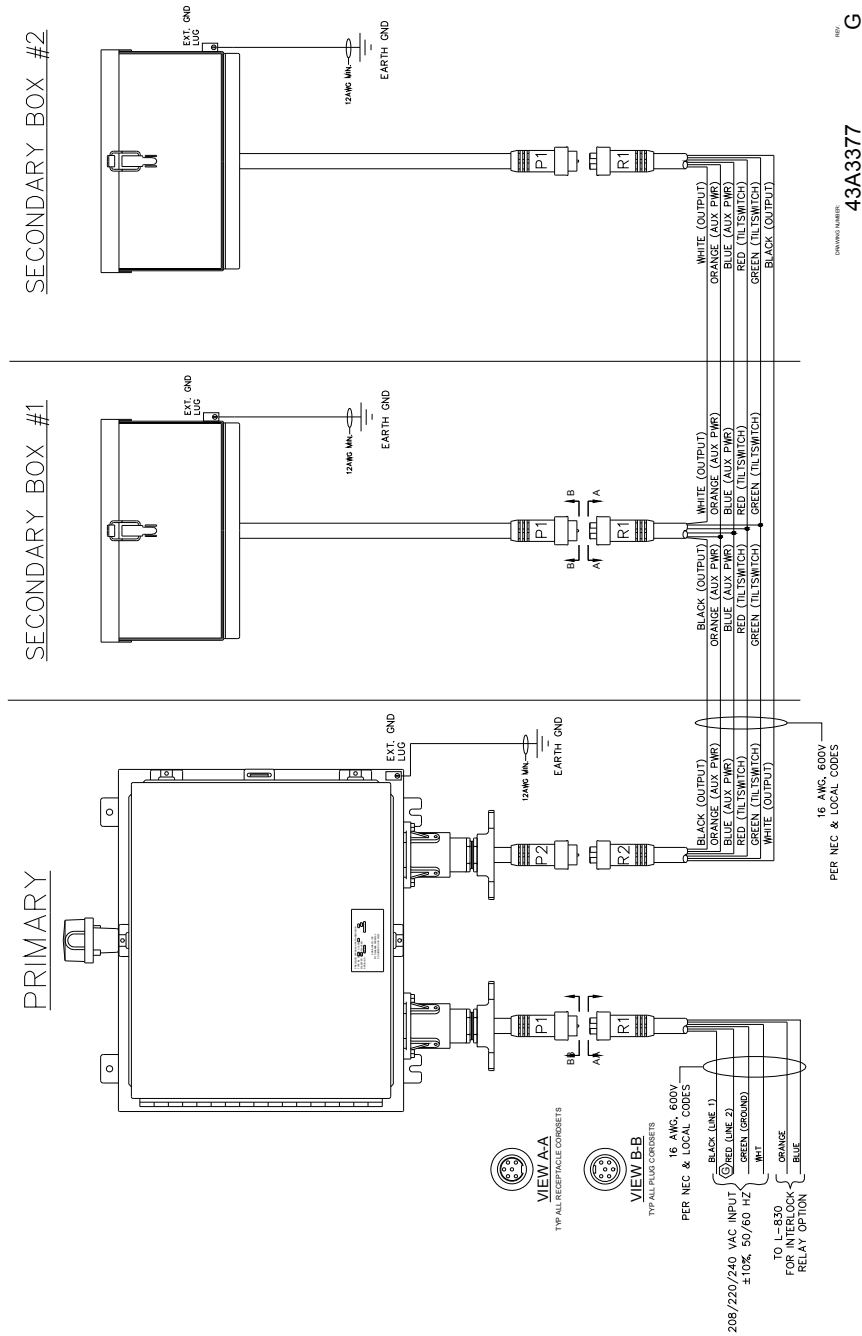

Figure 28: External Wiring, Single Channel PAPI Style A, L-880 (4 Box) System

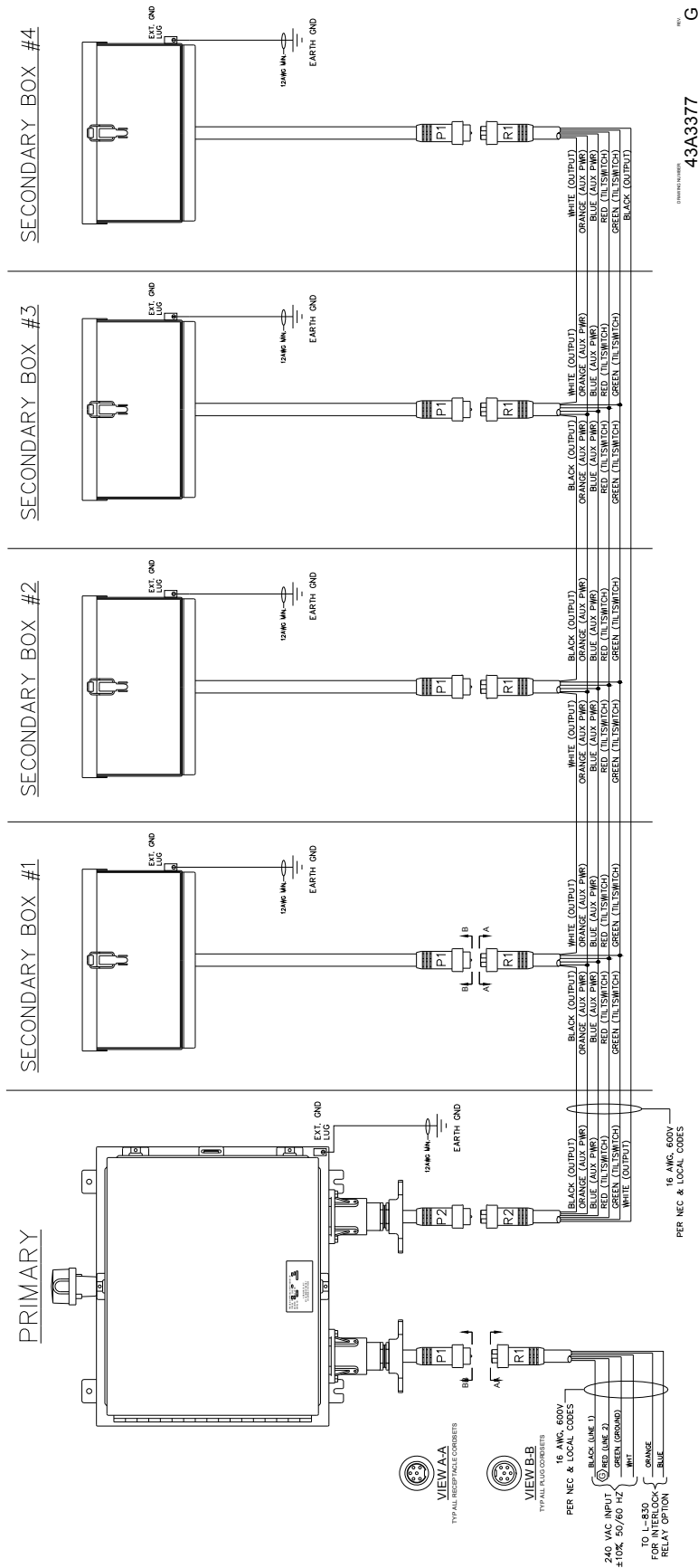

Figure 29: External Wiring, Single Channel PAPI Style B, L-881 (2 Box) System

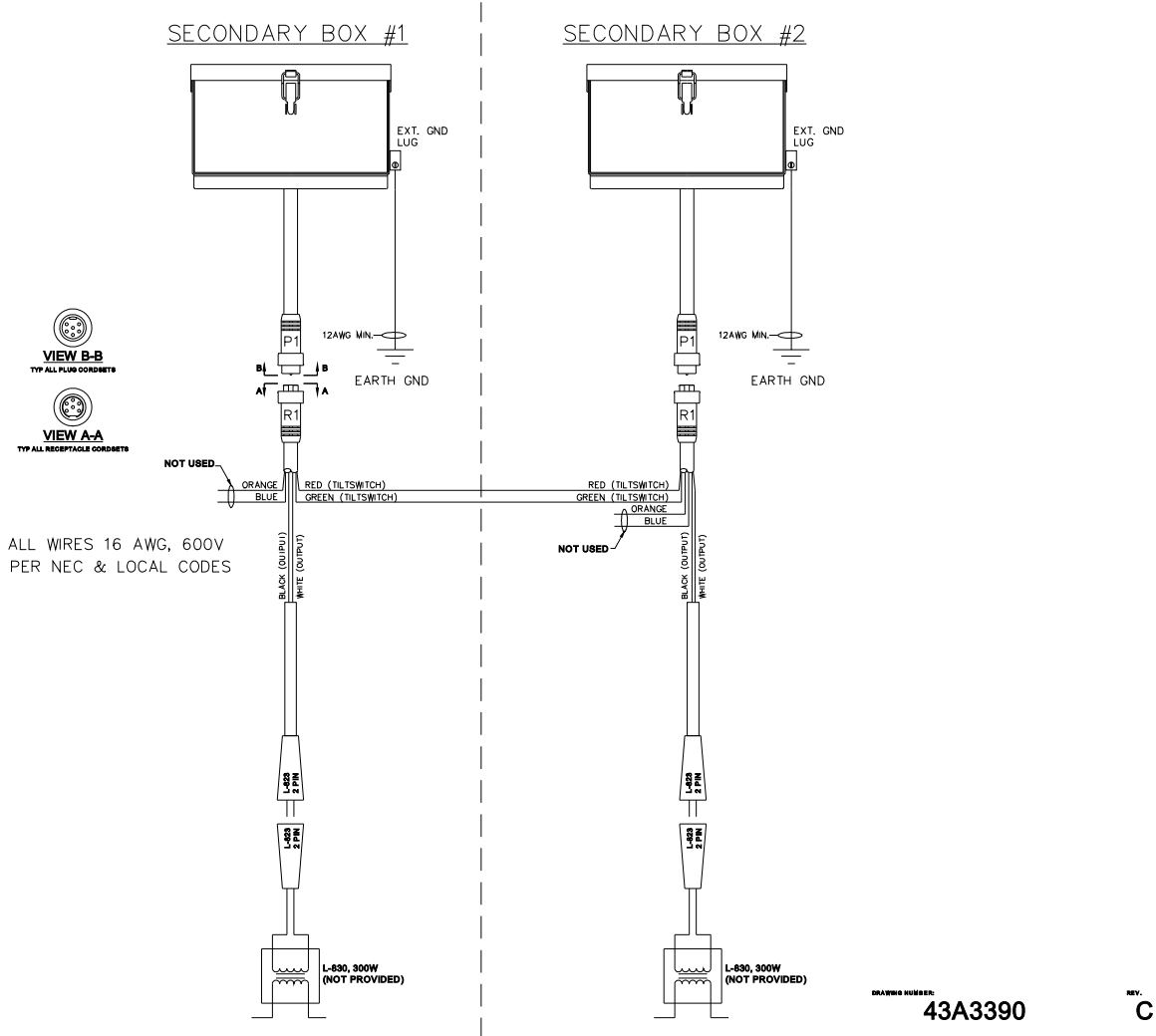
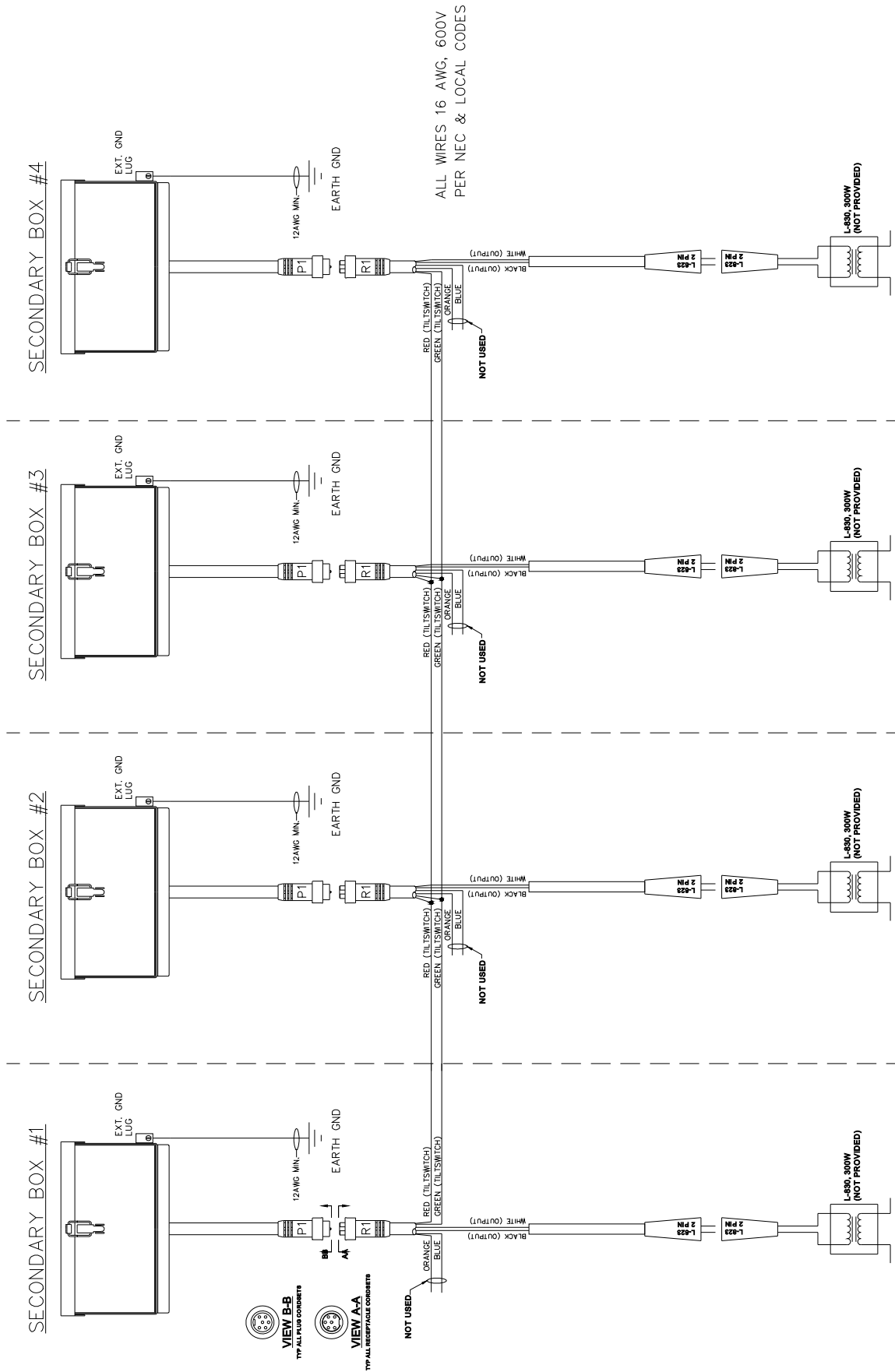

Figure 30: External Wiring, Single Channel PAPI Style B, L-880 (4 Box) System



REV. C

DATE/REV NUMBER: 43A3390

Figure 31: Power Control Unit (PCU) Wiring Schematic, Style A, 43A3292

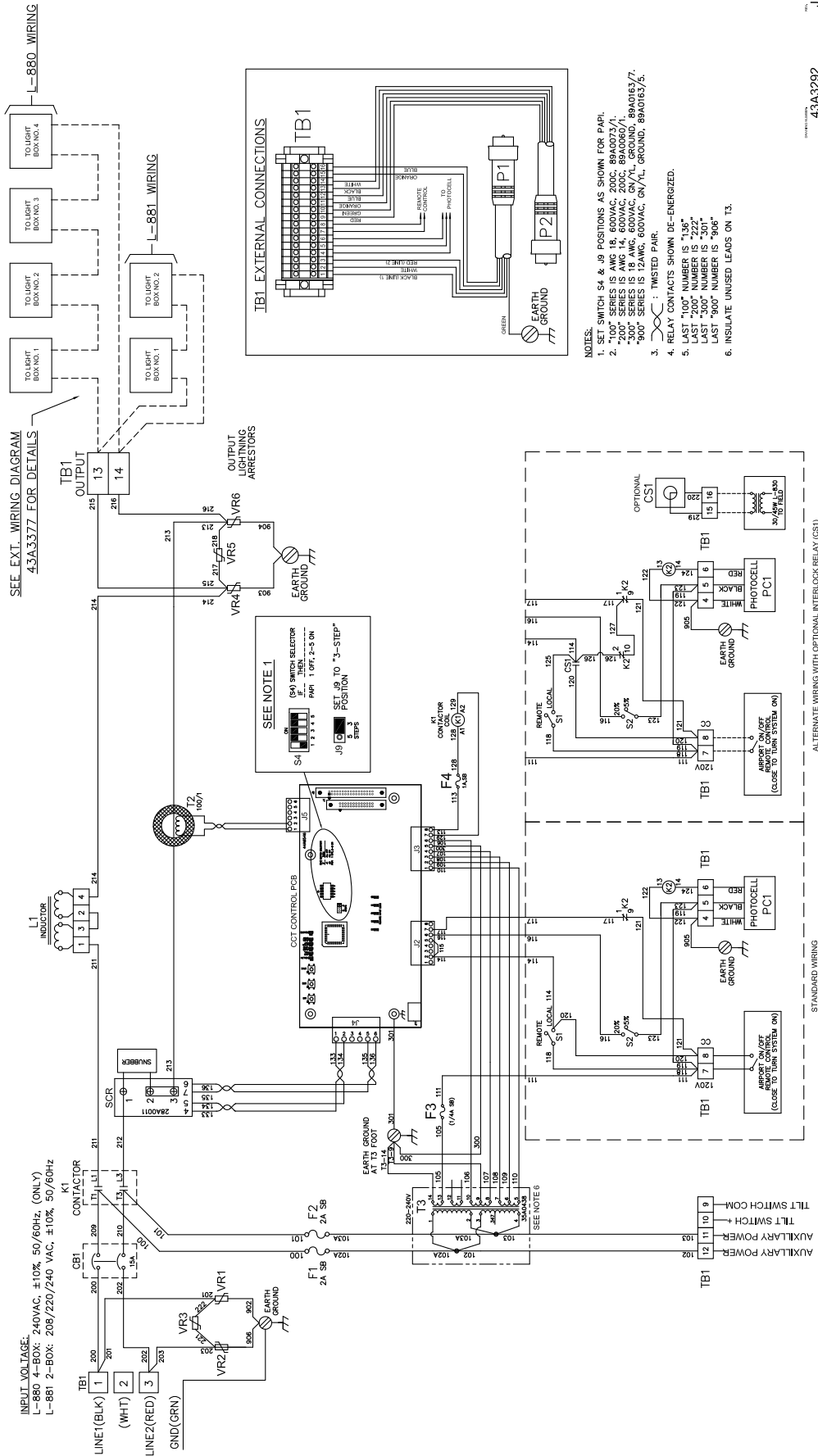

Figure 32: TB1 External Connections

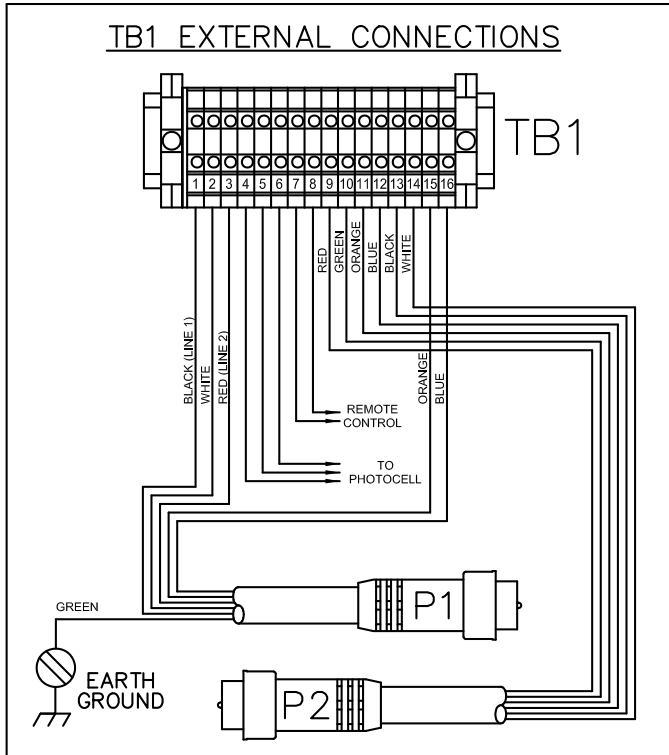
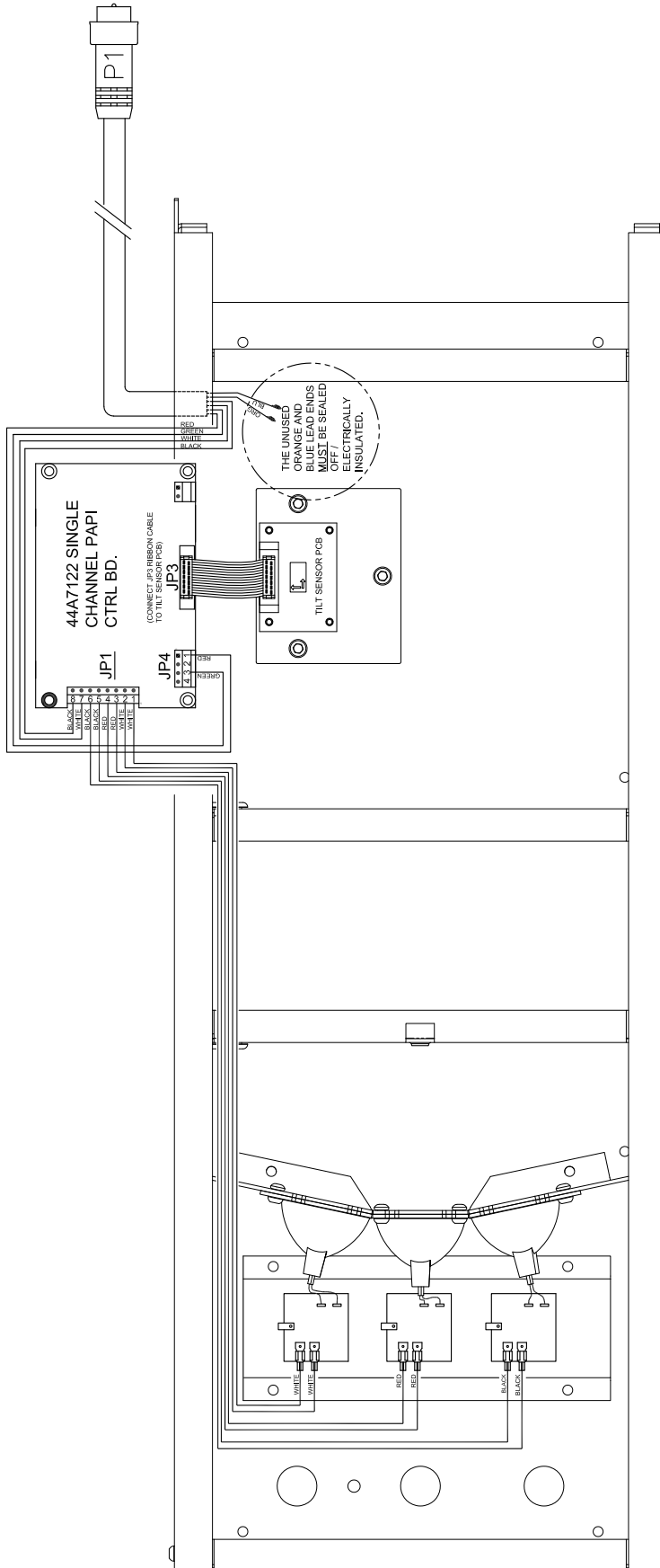
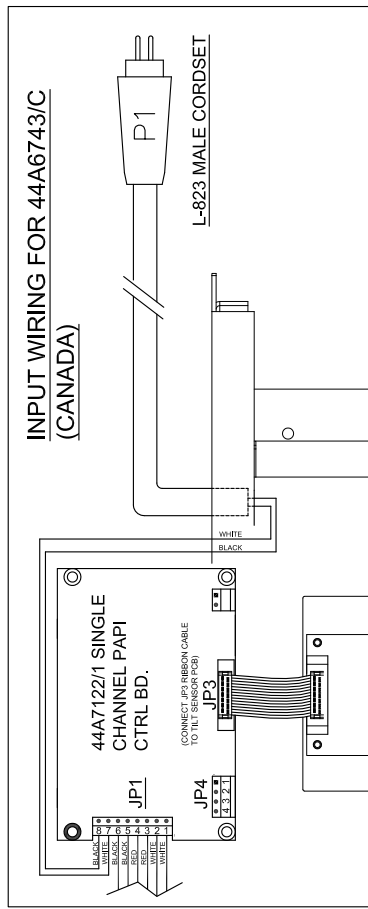

Figure 33: Single Channel PAPI Light Unit Connection Diagram, 43A3282



- NOTES:**
MATERIALS:
 - JP1/LAMP WIRE IS: 14AWG, 200C, (WHITE, BLK. & RED);
 - NO WIRE LABELS REQ'D.
 - REF. WIRE HARNESS 44A6737 & CORDSET 73A0130/8 FOR 44A6853.
 - REF. WIRE HARNESS 44A6737 & CORDSET 73A0108/6 FOR 44A6743/C (CUT FEMALE END OFF OF CORDSET).



43A3282 E

Figure 34: Single Channel PAPI Installation, 117A0047

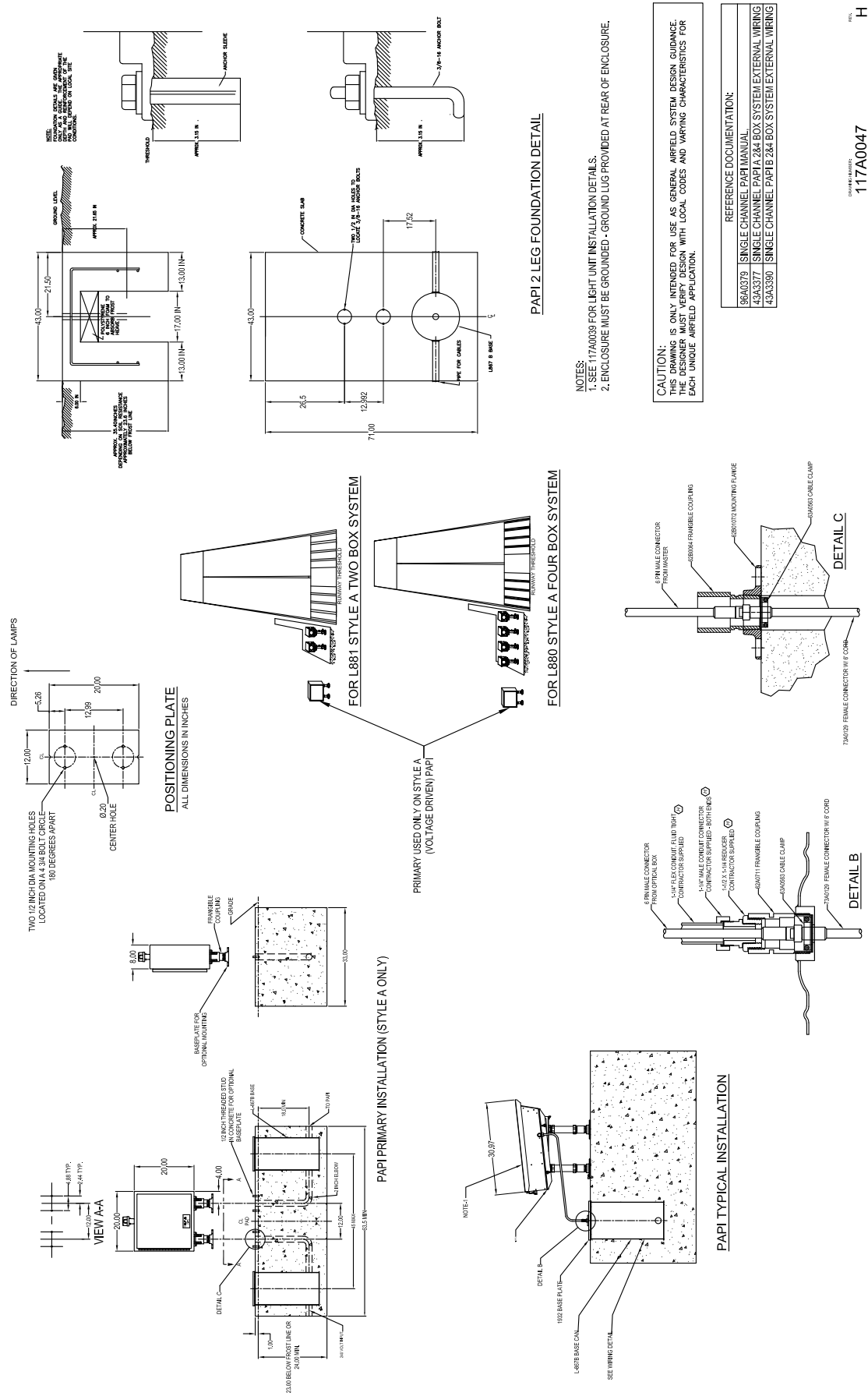

10.0 Single Channel PAPI Parts

To order parts, call ADB SAFEGATE Customer Service or your local representative.

This section provides parts drawings, along with part numbers. Refer to the “Schematics” for connections and wiring information.

Single Channel PAPI Ordering Code P A P □ / □ □ □ 0

Style

- A = PAPI A (Voltage powered)^{1,2}
- B = PAPI B (Current powered)

Type

- 2 = L-881 (2 Box)
- 4 = L-880 (4 Box)

Housing

- 0 = Aluminum Light Units (Standard)
- 1 = 316 Stainless Steel³

Interlock

- 0 = Without Interlock (PAPI A or B)
- 1 = With Interlock (PAPI A Only)⁴

0

Notes

- 1 L-881 input voltage is 208/220/240 VAC. L-880 input voltage is 240 VAC only.
- 2 Not ETL certified configuration.
- 3 For both the Style A and Style B PAPI, the light unit housing is stainless steel. For the Style A PAPI, the control box housing is also stainless steel.
- 4 Available only with the PAPI A. Interlock Relay Option provides ON/OFF control through current sensing of the runway series circuit during nighttime operations. During daytime, the PAPI is activated at the 100% step.

Single Channel PAPI EMT Kit

9 4 A 0 6 1 6 / □

Type

- 2 = L-881 (2 Box)
- 4 = L-880 (4 Box)

Figure 35: Installation Parts - 117A0039

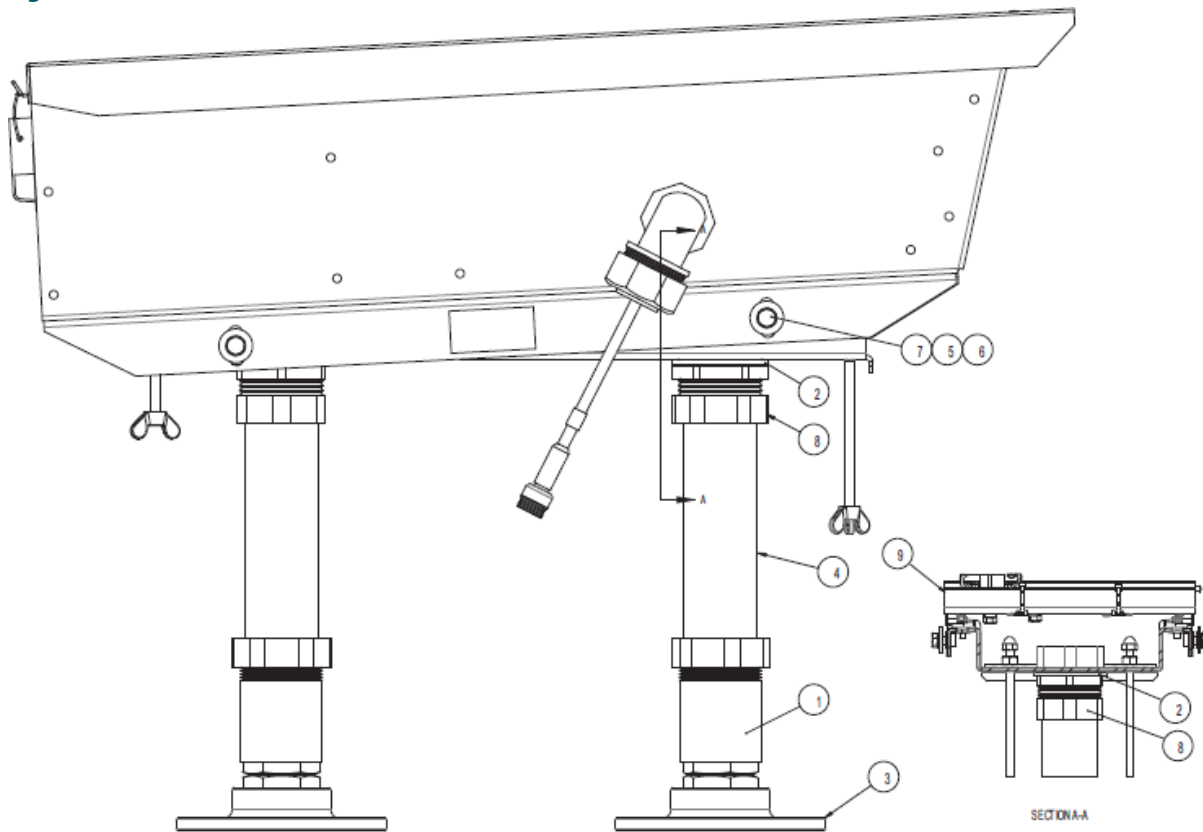

Table 17: Single Channel PAPI Light Unit Parts

Item No.	Part Number	Description	Qty.	Note
1	44B0180	Coupling, Frangible 2" EMT MS-17814-1	2	Provided with Enclosure
2	60A3346	Single-Channel PAPI Mounting Spacer	2	Provided with Enclosure
3	62B0107-2	Mounting Flange Plain Finish	2	Provided with Enclosure
4	N/A	2-inch EMT 2 3/16 OD ¹	2	Provided by Contractor
5	N/A	M8 Flat Washer	4	Provided with Enclosure
6	N/A	M8 Split Lockwasher	4	Provided with Enclosure
7	N/A	M8 X 16 Hex Bolt	4	Provided with Enclosure
8	77A0009	Compression Coupling 2" EMT	2	Provided with Enclosure
9	94A0496	Optional Single-Channel PAPI Extended Elevation Kit ²	1	Optional Kit

Notes

- ¹ 2-inch diameter EMT tubing (2-3/16 OD) to be provided and installed by contractor. Length to be determined at installation to adjust for uneven terrain and to mount optical box at correct elevation above the runway. 2-inch EMT tube to extend 3-1/4" into frangible coupling and full insertion into compression coupling to ensure stable installation. Tube must be painted international orange per FED-STD-595, Color 12197 to provide corrosion protection.
- ² 94A0496 extended elevation kit is optional for elevations in excess of 5 degrees.

Figure 36: Single Channel PAPI Light Unit - 44A6853

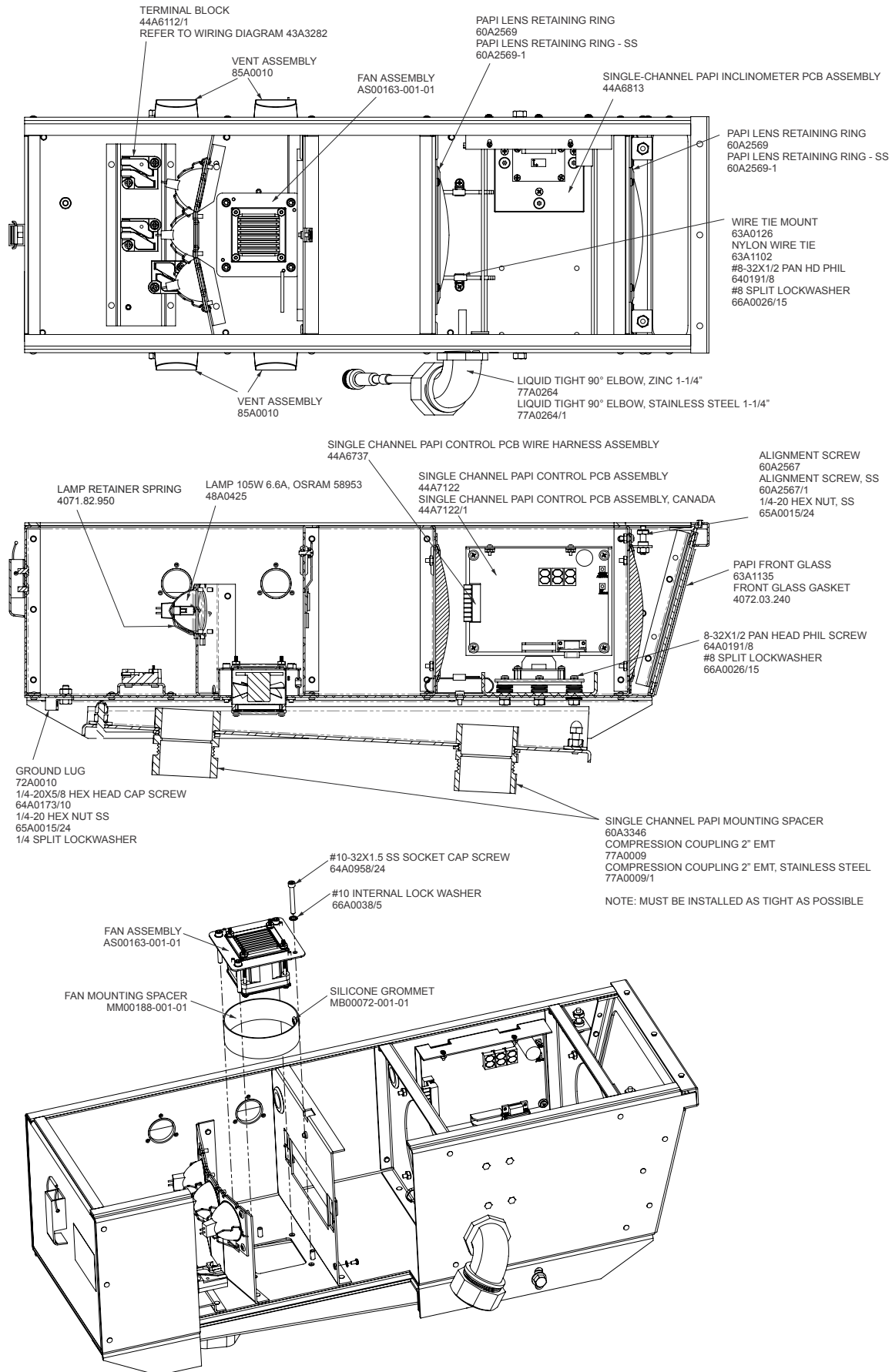

Figure 37: Single Channel PAPI Light Unit - 44A6853 (Continued)

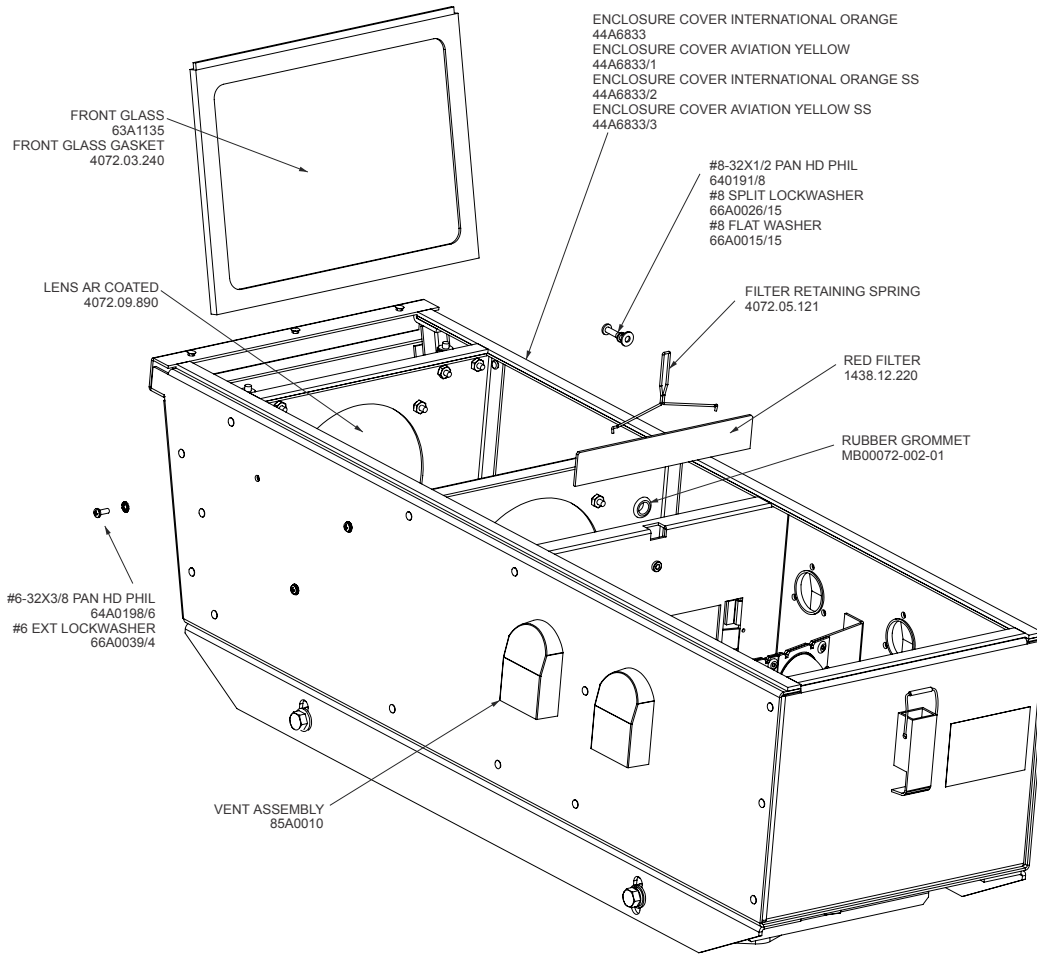

Table 18: Single Channel PAPI Light Unit Parts

Part Number	Description	Qty.	Qty.	Note
		44A6853	44A6853-C	
44A7122	Single-Channel PAPI Control PCB Assembly (Standard Version)	1	-	Tilt Switch Enabled
44A7122/1	Single-Channel PAPI Control PCB Assembly (Canada Version)	-	1	Tilt Switch Disabled
44A6737	Single-Channel PAPI Wire Harness Assembly	1	1	
44A6813	Single-Channel PAPI Inclinator PCB Assembly	1	1	
63A0126	Wire Tie Mount	2	2	
63A1102	Nylon Wire Tie	2	2	
64A0191/8	#8-32 X 1/2 Pan Head Phillips	14	14	
66A0026/15	#8 Split Lockwasher	20	20	
65A0015/15	#8-32 Hex Nut	8	8	
72A0010	Ground Lug	1	1	
64A0173/10	1/4-20 X 5/8 Hex Head	1	1	
65A0015/24	1/4-20 Hex Nut, SS	1	1	
66A0026/24	1/4 Split Lockwasher	1	1	

Table 18: Single Channel PAPI Light Unit Parts (Continued)

Part Number	Description	Qty.	Qty.	Note
		44A6853	44A6853-C	
64A0198/6	#6-32 X 3/8 Pan Head Phillips	3	3	
66A0039/4	#6 Ext Lockwasher	3	3	
77A0264	Liquid Tight 90° Elbow, Zinc 1-1/4"	1	0	
77A0264/1	Liquid Tight 90° Elbow, Stainless 1-1/4"	0	1	
89A0267/02	14-Pin Ribbon Cable, 2" Long	1	1	
85A0010	Vent Assembly	4	4	
AS00163-001-01	Fan Assembly	1	0	
64A0958/24	#10-32 X 1.5 Socket Cap Screw SS	4	4	
66A0038/5	#10 Internal Lockwasher	4	4	
1438.12.220	Red Filter	1	1	
4072.05.121	Filter Retaining Spring	1	1	
63A1135	Front Glass	1	1	
4072.03.240	Front Glass Gasket	1	1	
4072.09.890	Lens AR Coated	2	2	

Figure 38: Control Board Assembly 44A7122 (Canada: 44A7122/1)

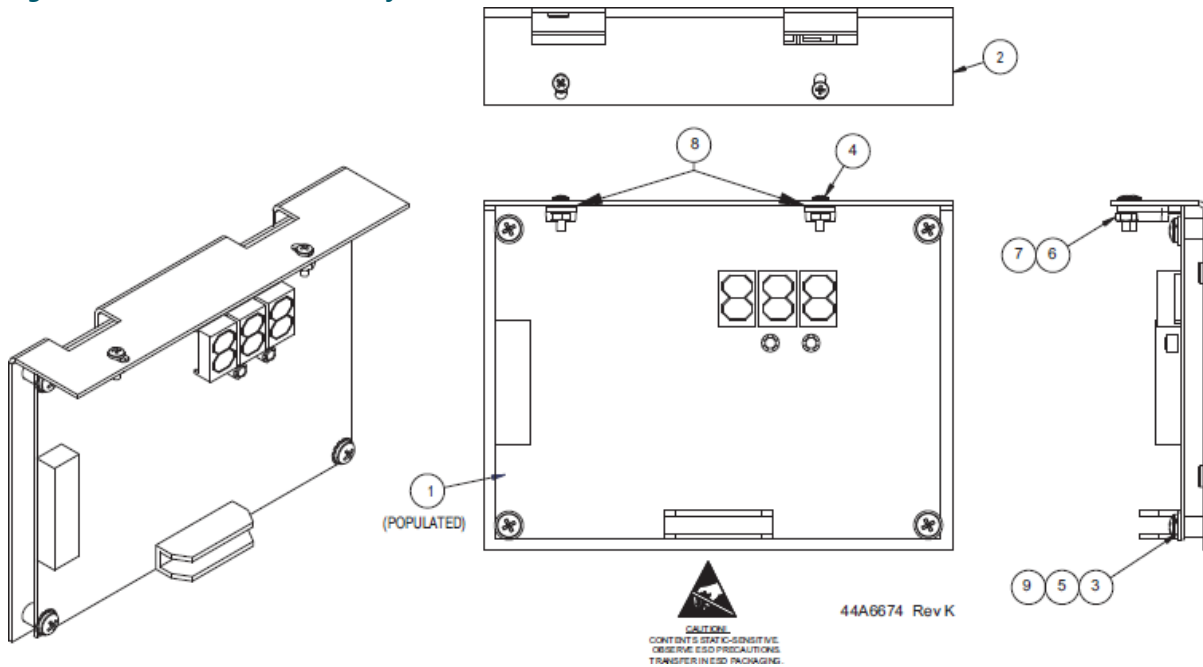

Table 19: Control Board Parts

Item No.	Part Number	Description	Units	Qty.
1	44A7122 or 44A7122-C	Control Board Assembly		
2	60A3270	Single-Channel PAPI Control PCB Bracket		
3	64A0191/4	Screw, 8-32 X 1/4, Pan Head, Phil, SS	Ea.	4
4	64A0169/6	Screw, 4-40 X 3/8, Pan Head, Phil, SS	Ea.	2
5	66A0039/5	#8 Ext. Lockwasher, SS	Ea.	4

Table 19: Control Board Parts (Continued)

Item No.	Part Number	Description	Units	Qty.
6	65A0015/7	Hex Nut, 4-40, SS	Ea.	2
7	66A0039/2	#4 Ext. Lockwasher, SS	Ea.	2
8	63A0857	TO-220 Silicone Pad	Ea.	2
9	66A0015/15	#8 FLAT WASHER	Ea.	4

Figure 39: Power Control Unit (PCU) Assembly, Style A, 44A6752/XXX

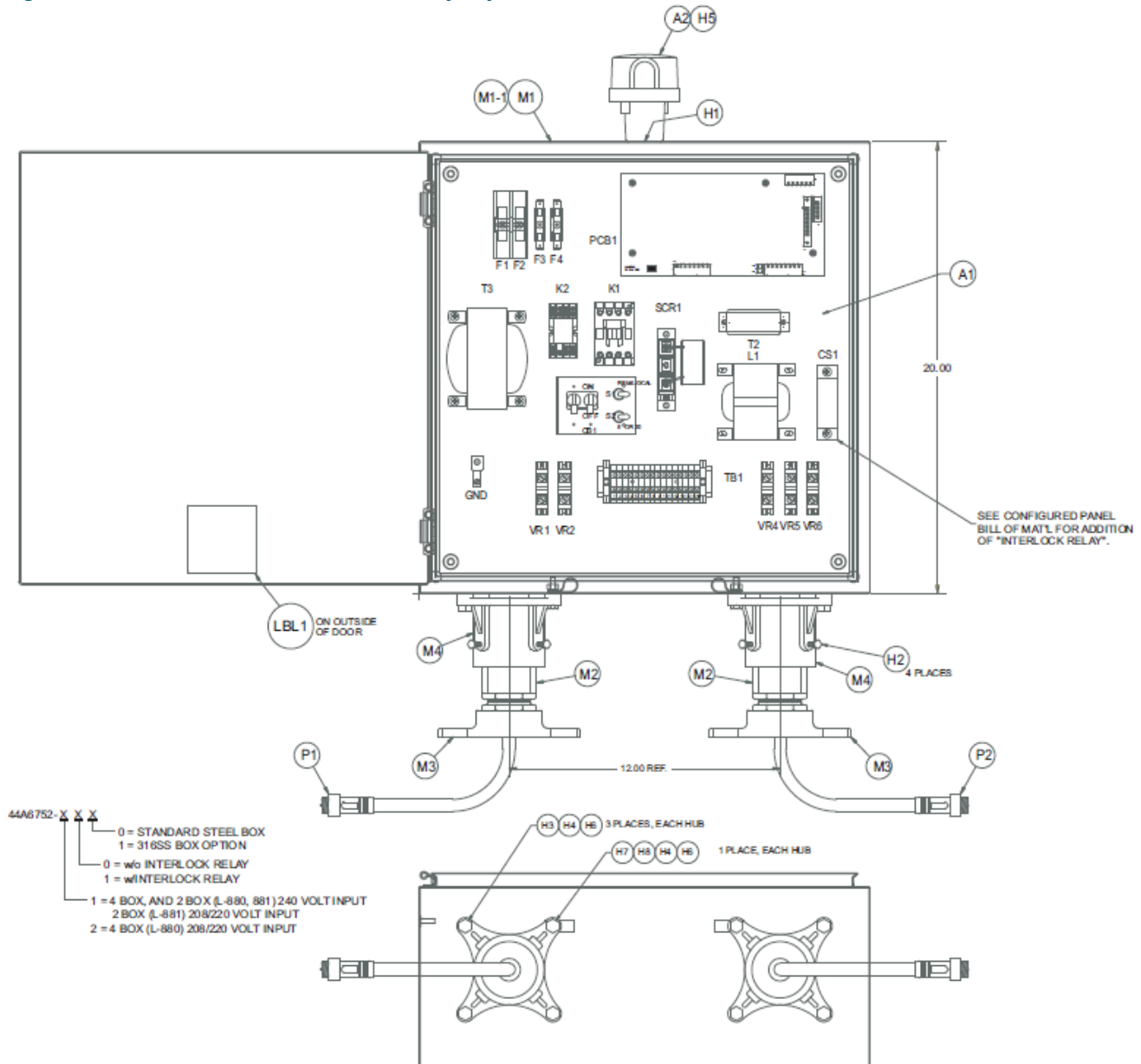

Table 20: Power Control Unit Parts

Item No.	Part Number	Qty.	Description	Note
LBL1	42A0307	1	Label PAPI	
A1	44A6703/XXXX	1	PAPI A Panel Assembly	See Figure 23
A2	48A0089	1	Photocell 120VAC	

Table 20: Power Control Unit Parts (Continued)

Item No.	Part Number	Qty.	Description	Note
H1	49A0095	1	Photocell Socket	
M1	60A3324	1	PAPI Power Control Unit (PCU) Enclosure, SC PAPI	
M1-1	60A3324/1	1	PAPI Power Control Unit (PCU) Enclosure, SC PAPI, 316SS	
M2	62B0064	2	Coupling 2" Frangible, Black, Threaded 1 End	
M3	62B0107/2	2	Mounting Flange	
M4	62C0068	2	Hub Mounting	
H2	64A0173/12	4	Bolt, 1/4-20 X ¾ Hex Head	
H3	64A0173/16	6	Bolt, 1/4-20 X 1 Hex Head	
H4	64A0015/24	8	1/4-20 Hex Nut	
H5	65A0117	1	1/2-14 Sealing Nut	
H6	66A0026/24	8	1/4 Split Lockwasher	
P1, P2	73A0180	2	Male Plug w/8' Cord, 6 Conductor/16AWG	
H7	62A0138/1	2	Cable Clamp	
H8	64A0173/20	2	Bolt, 1/4-20 X 1-1/4" Hex Head	

Figure 40: Power Control Unit Panel, Style A, 44A6703

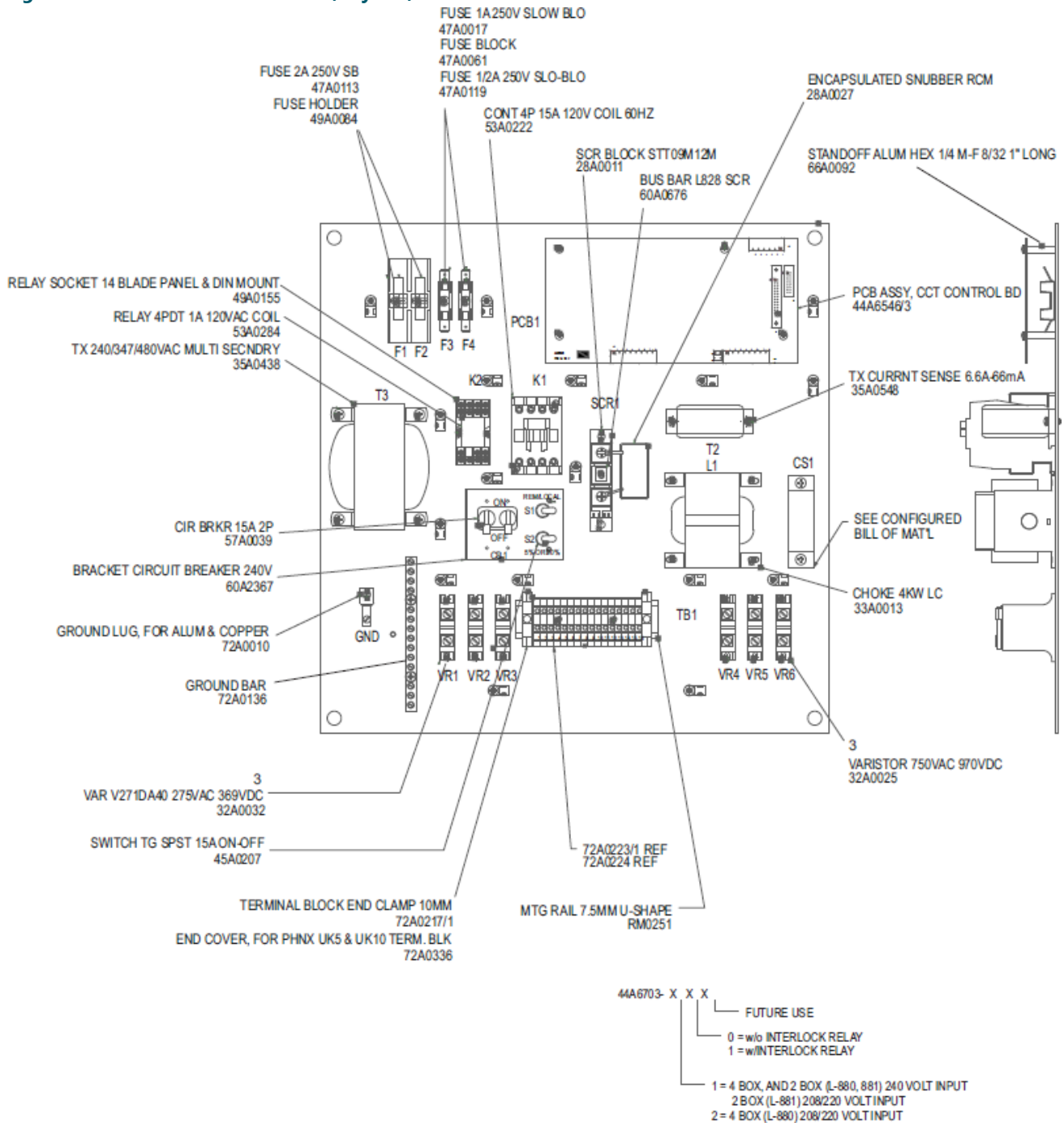

10.1 Spare Parts

It is recommended to create a sufficiently large stock of spare parts to maintain the Single Channel PAPI in the field. Consider acquiring approximately 10% spare final assemblies (with a minimum quantity of 1) for the total amount of equipment in the field. This allows for repairs to be made in the shop. Components that are less likely to need replacement, such as lenses, filters, gaskets and PCB sub-assemblies should be stocked in smaller quantities.

For the Single Channel PAPI unit, it is highly recommended to have a least one entire Single Channel PAPI unit as a spare for larger installations.

For the Single Channel PAPI see the table below for spares.

- Consider acquiring 10% spares for critical components noted as (A) in the table below. If only a small number of PAPI units are installed, consider acquiring at least 1 of each of the components noted as (A) below.
- Also consider acquiring 1% spares for parts noted as (B) in the table below. If it is important to have a robust level of spare parts on hand, and only a small number of PAPI units are installed, consider acquiring 1 of each of the components noted as (B) below.

Table 21: Light Unit Spare Parts

Part Number	Description	Location	Note	Spares
44A6853/S	SC PAPI Spare Light Unit			
44B0180	Frangible Coupling, 2-inch EMT	Figure 35		A
44A6813	Inclinometer PCB Assembly	Figure 36		B
48A0425	Lamp, 105W, 6.6A	Figure 36		A
1438.12.220	Red Filter	Figure 37		B
44A7122	Single Channel PAPI Control Board	Figure 36		B
AS00163-001-01	Fan Assembly	Figure 36		
94A0570/XXX	Baffle Kit	PAPI Baffle Retrofit Kit Ordering Code		



Note

Inclinometer 44A6813 (RevE or earlier) or 44A6813/INSL is replaced by 44A6813 (RevF or later).



Note

Upon initial replacement of either of the older PAPI Control Boards 44A6674 or 44A6674-1 or the inclinometer PCB assembly 44A6813 (RevE or earlier), you must replace both items with new PAPI control boards 44A7122 or 44A7122-1 and 44A6813 (RevF or later).

Table 22: Power Control Unit Spare Parts

Part Number	Description	Location	Note	Spares
44A6546-3	CCT Control Board	Figure 39		B
62B0064	Frangible Coupling, Control Box	Figure 39		B
47A0017	Fuse, 1A, SB (F4)	Figure 40		A
47A0049	Fuse, 2A, SB (F1, F2)	Figure 40		A
47A0119	Fuse, 0.5A, SB (F3)	Figure 40		A
48A0089	Photocell	Figure 39		A
44A6853	SC PAPI Optical Box	Figure 36		B
44A6853-1	SC PAPI Optical Box, Stainless Steel	Figure 36		B
44A6853-C	SC PAPI Optical Box, Tilt Switch Disabled	Figure 36		B
28A0011	SCR	Figure 40		B
28A0027	Snubber, SCR	Figure 40		A
32A0028	Varistor, 575V AC, Input	Figure 40		A
32A0025	Varistor, 750V AC, Output	Figure 40		A

Appendix A: SUPPORT

Our experienced engineers are available for support and service at all times, 24 hour/7 days a week. They are part of a dynamic organization making sure the entire ADB SAFEGATE is committed to minimal disturbance for airport operations.

ADB SAFEGATE Support

Live Technical Support - Americas

If at any time you have a question or concern about your product, just contact ADB SAFEGATE's technical service department. Trained in all areas of system issues, troubleshooting, quality control and technical assistance, our highly experienced Technical support specialists are available 24 hours a day, seven days a week to provide assistance over the phone.

ADB SAFEGATE **Americas Technical Service & Support (US & Canada): +1-800-545-4157**

ADB SAFEGATE Americas Technical Service & Support (International): +1-614-861-1304

During regular business hours, you can also Chat with a Service Technician. We look forward to working with you!

Before You Call

When you have an airfield lighting or system control system problem it is our goal to support airfield maintenance staff as quickly as possible. To support this effort we ask that you have the following information ready before calling.

- The *airport code*
- If not with an airport, then company name (prefer customer id number)
- Contact phone number and email address
- Product with part number preferable or product number
- Have you reviewed the product's manual and troubleshooting guide
- Do you have a *True RMS* meter available (and any other necessary tools)
- Be located with the product ready to troubleshoot

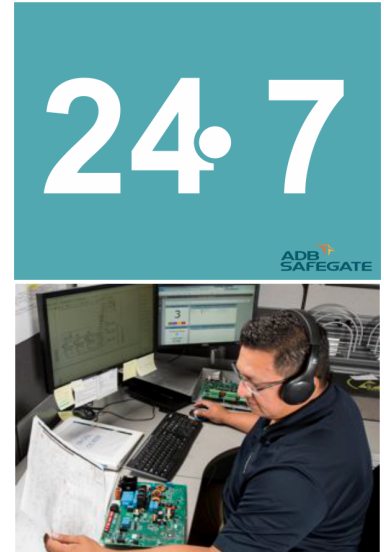

Note

For more information, see www.adbsafegate.com, or contact ADB SAFEGATE Support via email at support@adbsafegate.com or

Brussels: +32 2 722 17 11

Rest of Europe: +46 (0) 40 699 17 40

Americas: +1 614 861 1304. Press 3 for technical service or press 4 for sales support.

China: +86 (10) 8476 0106

A.1 ADB SAFEGATE Website

The ADB SAFEGATE website, www.adbsafegate.com, offers information regarding our airport solutions, products, company, news, links, downloads, references, contacts and more.

A.2 Recycling

A.2.1 Local Authority Recycling

The disposal of ADB SAFEGATE products is to be made at an applicable collection point for the recycling of electrical and electronic equipment. The correct disposal of equipment prevents any potential negative consequences for the environment and human health, which could otherwise be caused by inappropriate waste handling. The recycling of materials helps to conserve natural resources. For more detailed information about recycling of products, contact your local authority city office.

A.2.2 ADB SAFEGATE Recycling

ADB SAFEGATE is fully committed to environmentally-conscious manufacturing with strict monitoring of our own processes as well as supplier components and sub-contractor operations. ADB SAFEGATE offers a recycling program for our products to all customers worldwide, whether or not the products were sold within the EU.

ADB SAFEGATE products and/or specific electrical and electronic component parts which are fully removed/separated from any customer equipment and returned will be accepted for our recycling program.

All items returned must be clearly labeled as follows:

- For *ROHS/WEEE* Recycling
- Sender contact information (Name, Business Address, Phone number).
- Main Unit Serial Number.

ADB SAFEGATE will continue to monitor and update according for any future requirements for *EU directives* as and when *EU member states* implement new *regulations* and or *amendments*. It is our aim to maintain our *compliance plan* and assist our customers.

Company Addresses

ADB SAFEGATE, Belgium	ADB SAFEGATE BV Leuvensesteenweg 585, B-1930 Zaventem Belgium
Contact: Tel.: +32 2 722 17 11 Fax: +32 2 722 17 64	Email: marketing@adbsafegate.com Internet: www.adbsafegate.com
ADB SAFEGATE, Americas	ADB SAFEGATE Americas LLC 977 Gahanna Parkway, Columbus, OH 43230 USA
Contact: Tel.: +1 (614) 861 1304 Fax: +1 (614) 864 2069	Email: sales.us@adbsafegate.com Internet: www.adbsafegate.com
ADB SAFEGATE, Sweden	ADB SAFEGATE Sweden AB Djurhagegatan 19 SE-213 76 Malmö Sweden
Contact: Tel.: +46 (0)40 699 17 00 Fax: +46 (0)40 699 17 30	Email: marketing@adbsafegate.com Internet: www.adbsafegate.com
ADB SAFEGATE, China	ADB SAFEGATE Airfield Technologies Ltd. China Unit 603, D Block, CAMIC International Convention Center, No 3, Hua Jia Di East road, ChaoYang district, Beijing 100102 P.R. China
Contact: Tel.: +86 (10) 8476 0106 Fax: +86 (10) 8476 0090	Email: china@safegate.com Internet: www.adbsafegate.com
ADB SAFEGATE, Germany	ADB SAFEGATE Germany GmbH Konrad-Zuse-Ring 6, D-68163 Mannheim Germany
Contact: Tel.: +49 (621) 87 55 76-0 Fax: +49 (621) 87 55 76-55	Email: marketing@adbsafegate.com Internet: www.adbsafegate.com



Powering Your Airport Performance from Approach to Departure

adbsafegate.com

Copyright © ADB SAFEGATE, all rights reserved

