

Less light pollution. LED light beam provides less light "wash" in the sky, and on the ground



Features

- FAA ETL Certified, AIP Qualified
- 65% Power reduction over traditional metal halide lamps
- Instant on- no more waiting for bulbs to get to full bright!
- FAA Certificate of Conformance: L-801A(L)- Medium Intensity Airport Beacon (AC 150/5345-12F)
- ICAO: Aerodromes, Annex 14, Volume 1, Eighth Edition. Photometry – Chapter 5, Sec. 5.3.3.6 and 5.3.3.7
- Chromaticity – Appendix 1 Section 2.3.1
- One white LED lamp, One aviation green LED lamp
- 50,000 hour typical lamp life
- Patented belt-drive system eliminates the lubrication required by conventional gear-drive beacons (U.S. Pat. 5,339,224)
- Lamps preset 5° above horizontal, adjustable
- Optional stainless steel cabinet & bearings for highly corrosive environments
- Class I (No Heater) normal operating temperature range: 0°F to +131°F (-18°C to +55°C)
- Class 2 (With Heater) normal operating temperature range: -67°F to +131°F (-55°C to +55°C)
- Heater thermostatically controlled to engage at 0°F
- Optional tell-tale relay (monitors lamps and triggers dry contact on outage)
- Power Consumption L-801A(L):
Class I; 136W Class II; 536W
- Manufactured by Hali-Brite® Inc.

Applications:
L-801A Rotating Beacons are designed primarily for night operation as identification and location markers for airports.

Compliance with Standards: (ETL CERTIFIED)
FAA: L-801A(L) A/C150/5345-12F Medium Intensity Airport Beacon. ICAO: Annex 14, Volume 1



Optional Beacon Tipdown Pole

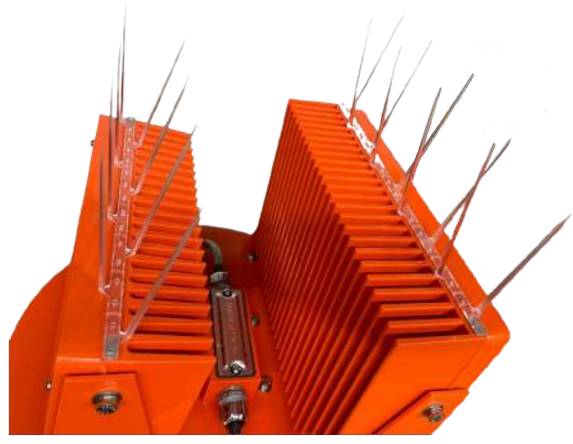

Optional Bird Spikes

Ordering Information

Part Number	Description
L801AL116	120 VAC, 60 Hz, Class I
L801AL125	220-240 VAC, 50 Hz, Class I
L801AL126	220-240 VAC, 60 Hz, Class I
L801AL216	120 VAC, 60 Hz, Class II
L801AL225	220-240 VAC, 50 Hz, Class II
L801AL226	220-240 VAC, 60 Hz, Class II

Note: 220-240VAC models are designed for overseas applications 220-240 volts LINE TO NEUTRAL

Options

Part Number	Description
L801/802 T/T HBM 120	Tell-Tale Relay, 120 VAC
L801/802 T/T HBM 240	Tell-Tale Relay, 220-240 VAC
L801/802 Bird Spikes	Large polycarbonate resin bird spikes running along each beacon head
L801 HBM SS	For corrosive environment installation within 100mi of saltwater. stainless steel cabinet, bearings, legs and hardware throughout
4200-0000A	Tower Mounting Kit-creates a platform from 36" beacon to LED model
Hali-Brite Tipdown	Hali-Brite Tipdown Pole
L801 Rapid Response	L801 rapid response repair kit: tools and parts for all common repairs, see Rapid Response cut sheet for details

Replacement Parts

Part Number	Description
0100-3944	Surge Protector
0200-0031	150 W Power Supply
0200-0030	70 W Power Supply
0600-0003	Drive Belt
4100-0000-1A	Motor 120VAC
4100-0006-2	Motor 230VAC
2500-0000-1	Motor Gearhead
5000-0004	Pulley, Motor
5000-0003	Pulley, Main Shaft
9200-0047	Head Assembly, White
9200-0054	Head Assembly, Green

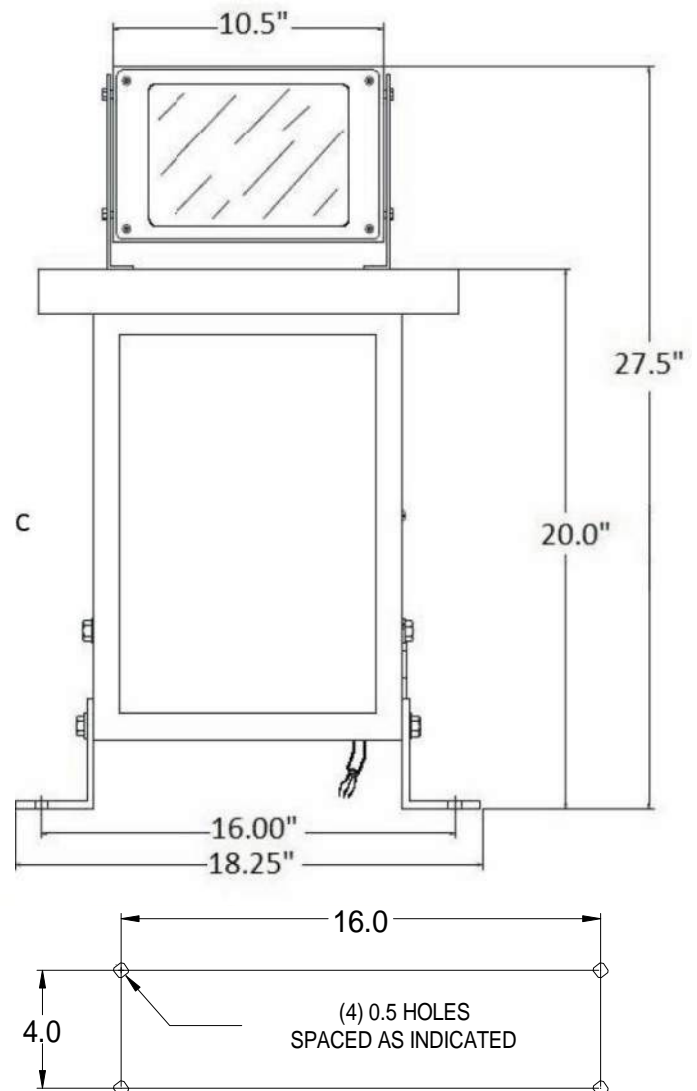

MOUNTING BOLT PATTERN

Shipping Information

Unpackaged Weight: 75 pounds
 Shipping Weight: 125 pounds
 Shipping Volume: 48"x40"x25"

ADB SAFEGATE Customer Service & Sales Support
 +1-800-545-4157, Press 4
salesupport@adbsafegate.com
 ADB SAFEGATE Technical Service & Support
 +1-800-545-4157, Press 3
techservice.us@adbsafegate.com