



RELIANCE Power CRF - Ferroresonant Constant Current Regulator

L-828/L-829, 2.5-30kW, 6.6A/20A, with RELIANCE Power ACE3

User Manual

DM00008-000-01, Rev. J, 2025/10/17

ADB 
SAFEGATE

A.0 Disclaimer / Standard Warranty

CE certification

The equipment listed as CE certified means that the product complies with the essential requirements concerning safety and hygiene. The European directives that have been taken into consideration in the design are available on written request to ADB SAFEGATE.

ETL certification

The equipment listed as ETL certified means that the product complies with the essential requirements concerning safety and C22.2 No.180:13 (R2018) regulations. The CSA directives that have been taken into consideration in the design are available on written request to ADB SAFEGATE.

All Products Guarantee

ADB SAFEGATE will correct by repair or replacement per the applicable guarantee below, at its option, equipment or parts which fail because of mechanical, electrical or physical defects, provided that the goods have been properly handled and stored prior to installation, properly installed and properly operated after installation, and provided further that Buyer gives ADB SAFEGATE written notice of such defects after delivery of the goods to Buyer. Refer to the Safety section for more information on Material Handling Precautions and Storage precautions that must be followed.

ADB SAFEGATE reserves the right to examine goods upon which a claim is made. Said goods must be presented in the same condition as when the defect therein was discovered. ADB SAFEGATE further reserves the right to require the return of such goods to establish any claim.

ADB SAFEGATE's obligation under this guarantee is limited to making repair or replacement within a reasonable time after receipt of such written notice and does not include any other costs such as the cost of removal of defective part, installation of repaired product, labor or consequential damages of any kind, the exclusive remedy being to require such new parts to be furnished.

ADB SAFEGATE's liability under no circumstances will exceed the contract price of goods claimed to be defective. Any returns under this guarantee are to be on a transportation charges prepaid basis. For products not manufactured by, but sold by ADB SAFEGATE, warranty is limited to that extended by the original manufacturer. This is ADB SAFEGATE's sole guarantee and warranty with respect to the goods; there are no express warranties or warranties of fitness for any particular purpose or any implied warranties of fitness for any particular purpose or any implied warranties other than those made expressly herein. All such warranties being expressly disclaimed.

Standard Products Guarantee

Products manufactured by ADB SAFEGATE are guaranteed against mechanical, electrical, and physical defects (excluding lamps) which may occur during proper and normal use for a period of two years from the date of ex-works delivery, and are guaranteed to be merchantable and fit for the ordinary purposes for which such products are made.



Note

See your applicable sales agreement for a complete warranty description.

Replaced or repaired equipment under warranty falls into the warranty of the original delivery. No new warranty period is started for these replaced or repaired products.

FAA Certified products manufactured by ADB SAFEGATE

ADB SAFEGATE L858 Airfield Guidance Signs are warranted against mechanical and physical defects in design or manufacture for a period of 2 years from date of installation, per FAA AC 150/5345-44 (applicable edition).

ADB SAFEGATE LED products (with the exception of obstruction lighting) are warranted against electrical defects in design or manufacture of the LED or LED specific circuitry for a period of 4 years from date of installation, per FAA EB67 (applicable edition). These FAA certified constant current (series) powered LED products must be installed, interfaced and powered with and through products certified under the FAA Airfield Lighting Equipment Program (ALECP) to be included in this 4 (four) year warranty. This includes, but is not limited to, interface with products such as Base Cans, Isolation Transformers, Connectors, Wiring, and Constant Current Regulators.



Note

See your sales order contract for a complete warranty description.

Replaced or repaired equipment under warranty falls into the warranty of the original delivery. No new warranty period is started for these replaced or repaired products.

Liability



WARNING

Use of the equipment in ways other than described in the catalog leaflet and the manual may result in personal injury, death, or property and equipment damage. Use this equipment only as described in the manual.

ADB SAFEGATE cannot be held responsible for injuries or damages resulting from non-standard, unintended uses of its equipment. The equipment is designed and intended only for the purpose described in the manual. Uses not described in the manual are considered unintended uses and may result in serious personal injury, death or property damage.

Unintended uses, includes the following actions:

- Making changes to equipment that have not been recommended or described in this manual or using parts that are not genuine ADB SAFEGATE replacement parts or accessories.
- Failing to make sure that auxiliary equipment complies with approval agency requirements, local codes, and all applicable safety standards if not in contradiction with the general rules.
- Using materials or auxiliary equipment that are inappropriate or incompatible with your ADB SAFEGATE equipment.
- Allowing unskilled personnel to perform any task on or with the equipment.

Copyright Statement

This manual or parts thereof may not be reproduced, stored in a retrieval system, or transmitted, in any form or by any means, electronic, mechanical, photocopying, recording, nor otherwise, without the author's prior written consent.

This manual could contain technical inaccuracies or typographical errors. The author reserves the right to revise this manual from time to time in the contents thereof without obligation of the author to notify any person of such revision or change. Details and values given in this manual are average values and have been compiled with care. They are not binding, however, and the author disclaims any liability for damages or detriments suffered as a result of reliance on the information given herein or the use of products, processes or equipment to which this manual refers. No warranty is made that the use of the information or of the products, processes or equipment to which this manual refers will not infringe any third party's patents or rights. The information given does not release the buyer from making their own experiments and tests.

Table of Contents

1.0 Safety	1
1.1 Safety Messages.....	1
1.1.1 Introduction to Safety.....	2
1.1.2 Intended Use.....	2
1.1.3 Material Handling Precautions : Storage.....	3
1.1.4 Material Handling: Heavy Equipment.....	3
1.1.5 Operation Safety.....	3
1.1.6 Maintenance Safety.....	4
1.1.7 Material Handling Precautions, ESD.....	4
1.1.8 Arc Flash and Electric Shock Hazard.....	5
2.0 Introduction	7
2.1 About this manual	7
2.2 How to work with the manual.....	7
2.3 CRF Introduction.....	7
2.4 Constant Current Regulator	7
2.5 Remote Control Input	9
2.6 Total Harmonic Distortion* (THD).....	9
2.7 Theory of Operation Introduction.....	9
2.8 ACE3 Unit	10
2.9 CCR Theory of Operation.....	10
2.9.1 Power Circuit.....	10
2.9.2 Output Measurement.....	10
2.9.3 URC4 Control PCB	10
2.9.4 URC4 Control PCB Inputs/Outputs	11
3.0 Theory of Operation	13
3.1 Output Current Monitor Circuitry	13
3.2 Output Current Configuration	13
3.3 Local Control Switch Operation.....	13
3.4 Contactor Drive.....	13
3.5 Remote Control Position Detection	13
3.6 Fault Protection.....	13
3.6.1 Overcurrent Protection	13
3.6.2 Open Circuit Protection.....	13
3.7 L-828 CCR.....	14
3.8 L-829 CCR.....	14
3.9 URC4 CCR Controller	14
3.9.1 L-829 Advanced Control Equipment.....	15
3.10 L-828/L-829 CCR Monitoring Options.....	15
3.10.1 Optional Insulation Resistance Monitoring System.....	16
3.11 Optional Series Cutout Type SCO.....	16
3.12 Optional Current Clamp Test Point.....	17
3.13 L-828 CCRs Required Equipment	17
3.14 Electrical Connections.....	18
3.15 Input Power Breaker Sizing.....	18
4.0 Specifications	21
4.1 Efficiency.....	21
4.2 Output Current Regulation.....	21
4.3 Protection Devices.....	22
4.4 Open-Circuit Protection	22
4.5 Overcurrent Protection.....	22
4.6 Input Voltage	22
4.7 Built-In True-RMS Ammeter (L-828 only).....	22
4.8 Input Power Monitoring Option via ACE3™	22
5.0 Installation	23
5.1 Introduction to Safety	23
5.2 Unpacking.....	23
5.2.1 Material Handling Precautions : Storage	24

5.3 Installation Overview.....	24
5.3.1 Mounting Information	24
5.3.2 Stacking Information	25
5.4 Installation - Wiring the CCR.....	27
6.0 Operation.....	31
6.1 Operation Safety.....	31
6.2 CCR Control Procedures	31
6.2.1 Local Control.....	31
6.2.2 Remote Control	32
6.2.3 CCR Door Interlock.....	33
6.2.4 CCR Shutdown Procedure.....	33
6.3 CCR Adjustment Procedures.....	34
6.3.1 Adjusting Output Current (no ACE3)	35
6.3.2 Adjusting Over-Current Detection Set Point (no ACE).....	36
6.4 SCO Operation	36
7.0 Graphic User Interface (GUI)	39
7.1 Menu Screen.....	42
7.1.1 Alarms View.....	43
7.1.2 Events View	44
7.1.3 Status Menu – Hours/Cycle Count	44
7.1.4 Status Menu – Waveform	45
7.1.5 Status Menu – Miscellaneous	45
7.1.6 CCR Menu - Configuration	46
7.1.6.1 Screen 1.....	46
7.1.6.2 Screen 2.....	47
7.1.6.3 Screen 3.....	48
7.1.6.4 Screen 4.....	49
7.1.6.5 Screen 5.....	49
7.1.7 CCR Menu – Measurement Calibration.....	50
7.1.8 CCR Menu – VA Calibration	51
7.1.9 CCR Menu – IRMS Configuration.....	53
7.1.10 CCR Menu – Lamps Out Calibration	54
7.1.11 ACE Menu - Configuration	57
7.1.12 ACE Menu – Failsafe.....	59
7.1.13 ACE Menu – Feature Enable.....	59
7.1.14 ACE Menu – About	60
8.0 Maintenance and Repair.....	63
8.1 Maintenance Safety.....	63
8.2 Maintenance Schedule.....	63
8.2.1 Short-Circuit Test.....	64
8.2.2 Open-Circuit Test.....	64
8.3 Component Replacement Procedures	65
8.3.1 Removing and Replacing URC4 Regulator Control PCB.....	65
8.3.1.1 DIP Switches Bank Positions	66
8.3.2 Removing and Replacing Input Lightning Arrestors.....	68
8.3.3 Removing and Replacing Output Lightning Arrestors	68
8.4 Wiring Schematics	70
9.0 Troubleshooting.....	77
9.1 General Troubleshooting Chart.....	77
9.2 Preliminary Troubleshooting	79
9.3 Troubleshooting Control Board.....	80
10.0 CRF Parts.....	81
10.1 Ordering Code.....	81
10.2 Ordering Code.....	0
10.3 CCR Options and Kits	81
10.4 Spare Parts	82
10.5 Assembly Views.....	85
A.0 SUPPORT	89
A.1 ADB SAFEGATE Website.....	89

A.2 Recycling	90
A.2.1 Local Authority Recycling	90
A.2.2 ADB SAFEGATE Recycling	90

List of Figures

Figure 1: L-828 CCR Power Circuit Block Diagram	11
Figure 2: L-828 CCR	14
Figure 3: L-829 CCR with ACE3.....	14
Figure 4: URC4 CCR Controller.....	15
Figure 5: ACE3 Control Board	15
Figure 6: SCO - Series Circuit Cutout, 1475.92.030	17
Figure 7: SCO - Series Circuit Cutout, ALSC.....	17
Figure 8: Side view of stacked CRF or CRT regulators.	26
Figure 9: Recommended Conduit interface Locations.....	27
Figure 10: Switch (3-Step/5-Step)	32
Figure 11: Output Current Clamp	34
Figure 12: Regulator URC4 Control PCB.....	35
Figure 13: Output Current Gauge	40
Figure 14: Output View and Diagram View	41
Figure 15: IO Card Cage View.....	41
Figure 16: Regulator Interface Card View	41
Figure 17: Regulator Interface Card View (4x4 Card).....	42
Figure 18: Alarms and Warnings Screen (Alarms View)	43
Figure 19: Alarms and Warnings Screen (Events View)	44
Figure 20: Hour/Cycle Count Screen.....	44
Figure 21: Wave Form Screen	45
Figure 22: Status Menu – Miscellaneous.....	45
Figure 23: Status Menu – Miscellaneous.....	46
Figure 24: CCR Configuration Screen 1.....	46
Figure 25: CCR Configuration Screen 1 for 20A CCRs.....	47
Figure 26: CCR Configuration Screen 2.....	48
Figure 27: Current Set Point.....	48
Figure 28: Current Set Point for 20A CCRs.....	48
Figure 29: I/O CCR Alarm	49
Figure 30: CSS Loops	49
Figure 31: Calibration Screen.....	51
Figure 32: Calibration Screen Override	51
Figure 33: Calibration Screen with the red X shown	51
Figure 34: ACE Info Config Screen (network Config).....	58
Figure 35: Failsafe Config Screen	59
Figure 36: About Screen	60
Figure 37: About Screen Menu	61
Figure 38: About Screen Disclaimer	61
Figure 39: PCB URC4 Regulator Control (44A7693)	65
Figure 40: Output Lightning Arrestors.....	69
Figure 41: Internal Wiring Schematic (Main, sheet 1/page 1).....	70
Figure 42: Internal Wiring Schematic (Main, sheet 1/page 2).....	71
Figure 43: Internal Wiring Schematic (Details A–D)	72
Figure 44: Internal Wiring Schematic (Details E–F)	73
Figure 45: Internal Wiring Schematic (Detail G - ACE3)	74
Figure 46: Internal Wiring Schematic (T1)	75
Figure 47: Internal Wiring Schematic (T4)	76
Figure 48: The URC4 Control Board	80
Figure 49: Component Plate (Front View)	85

Figure 50: Component Plate (Rear View).....	86
Figure 51: Door Parts (Internal View).....	87
Figure 52: Assembly View (Door Open, Side Removed).....	88

List of Tables

Table 1: Required Equipment Supplied.....	18
Table 2: Required Equipment Not Supplied	18
Table 3: Full Load Input Current.....	19
Table 4: Class, Style and Power Ratings	21
Table 5: Power Factor	21
Table 6: Efficiency	21
Table 7: Output Current and Limits	21
Table 8: Clearance specifications	24
Table 9: Remote Control Connections (3-Step/6.6 A).....	29
Table 10: Remote Control Connections (5-Step/6.6 A).....	29
Table 11: Remote Vac Control Connections (5-Step/20 A).....	29
Table 12: Input/Output Connections	29
Table 13: Output Current from Rotary Switch (3-Step/6.6A).....	32
Table 14: Output Current from Rotary Switch (5-Step/6.6 A).....	32
Table 15: Output Current from Rotary Switch (5-Step/20 A).....	32
Table 16: Remote Control.....	33
Table 17: Cutout Working Positions.....	37
Table 18: L-828/L-829 CCR (4-30 kW) Maintenance	63
Table 19: DIP Switch Bank 1	66
Table 20: DIP Switch Bank 2.....	67
Table 21: DIP Switch Bank 3.....	67
Table 22: CCR Troubleshooting	77
Table 23: Diagnostic LEDs on the Control Board	80
Table 24: Remote Input Status	80
Table 25: F1-F2 Fuses	83
Table 26: F3-F4 Fuses	83
Table 27: K2 Contactor.....	83
Table 28: Capacitor Banks.....	83

1.0 Safety

Introduction to Safety







This section contains general safety instructions for installing and using ADB SAFEGATE equipment. Some safety instructions may not apply to the equipment in this manual. Task- and equipment-specific warnings are included in other sections of this manual where appropriate.

1.1 Safety Messages

HAZARD Icons used in this manual

For all HAZARD symbols in use, see the Safety section. All symbols must comply with ISO and ANSI standards.

Carefully read and observe all safety instructions in this manual, which alert you to safety hazards and conditions that may result in personal injury, death or property and equipment damage and are accompanied by the symbols shown below.

	<p>WARNING</p> <p>Failure to observe a warning may result in personal injury, death or equipment damage.</p>
	<p>DANGER – Risk of electrical shock or ARC FLASH</p> <p>Disconnect equipment from line voltage. Failure to observe this warning may result in personal injury, death, or equipment damage. ARC Flash may cause blindness, severe burns or death.</p>
	<p>WARNING – Wear personal protective equipment</p> <p>Failure to observe may result in serious injury.</p>
	<p>WARNING – Do not touch</p> <p>Failure to observe this warning may result in personal injury, death, or equipment damage.</p>
	<p>CAUTION</p> <p>Failure to observe a caution may result in equipment damage.</p>
	<p>ELECTROSTATIC SENSITIVE DEVICES</p> <p>This equipment may contain electrostatic devices.</p>

Qualified Personnel

	<p>Important Information</p> <p>The term qualified personnel is defined here as individuals who thoroughly understand the equipment and its safe operation, maintenance and repair. Qualified personnel are physically capable of performing the required tasks, familiar with all relevant safety rules and regulations and have been trained to safely install, operate, maintain and repair the equipment. It is the responsibility of the company operating this equipment to ensure that its personnel meet these requirements.</p> <p>Always use required personal protective equipment (PPE) and follow safe electrical work practice.</p>
---	---

1.1.1 Introduction to Safety



CAUTION

Unsafe Equipment Use

This equipment may contain electrostatic devices, hazardous voltages and sharp edges on components

- Read installation instructions in their entirety before starting installation.
- Become familiar with the general safety instructions in this section of the manual before installing, operating, maintaining or repairing this equipment.
- Read and carefully follow the instructions throughout this manual for performing specific tasks and working with specific equipment.
- Make this manual available to personnel installing, operating, maintaining or repairing this equipment.
- Follow all applicable safety procedures required by your company, industry standards and government or other regulatory agencies.
- Install all electrical connections to local code.
- Use only electrical wire of sufficient gauge and insulation to handle the rated current demand. All wiring must meet local codes.
- Route electrical wiring along a protected path. Make sure they will not be damaged by moving equipment.
- Protect components from damage, wear, and harsh environment conditions.
- Allow ample room for maintenance, panel accessibility, and cover removal.
- Protect equipment with safety devices as specified by applicable safety regulations
- If safety devices must be removed for installation, install them immediately after the work is completed and check them for proper functioning prior to returning power to the circuit.

Failure to follow these instructions can result in serious injury, death or equipment damage

Additional Reference Materials



Important Information

- IEC – International Standards and Conformity Assessment for all electrical, electronic and related technologies.
- IEC 60364 – Electrical Installations in Buildings.
- CSA – C22.2 No.180:13 (R2018), series isolating transformers for airport lighting.
- FAA Advisory: AC 150/5340-26 (current edition), Maintenance of Airport Visual Aid Facilities.
- Maintenance personnel must refer to the maintenance procedure described in the ICAO Airport Services Manual, Part 9.
- ANSI/NFPA 79, Electrical Standards for Metalworking Machine Tools.
- National and local electrical codes and standards.

1.1.2 Intended Use



CAUTION

Use this equipment as intended by the manufacturer

This equipment is designed to perform a specific function, do not use this equipment for other purposes

- Using this equipment in ways other than described in this manual may result in personal injury, death or property and equipment damage. Use this equipment only as described in this manual.

Failure to follow this instruction can result in serious injury or equipment damage

1.1.3 Material Handling Precautions : Storage



CAUTION

Improper Storage

Store this equipment properly

- If equipment is to be stored prior to installation, it must be protected from the weather and kept free of condensation and dust.

Failure to follow this instruction can result in equipment damage

1.1.4 Material Handling: Heavy Equipment



DANGER

UNSTABLE LOAD

USE CAUTION WHEN MOVING HEAVY EQUIPMENT

- USE EXTREME CARE WHEN MOVING HEAVY EQUIPMENT.
- VERIFY THAT THE MOVING EQUIPMENT IS RATED TO HANDLE THE WEIGHT.
- WHEN REMOVING EQUIPMENT FROM A SHIPPING PALLET, CAREFULLY BALANCE AND SECURE IT USING A SAFETY STRAP.

FAILURE TO FOLLOW THIS INSTRUCTION CAN RESULT IN DEATH, SERIOUS INJURY, OR EQUIPMENT DAMAGE

1.1.5 Operation Safety



CAUTION

Improper Operation

Do Not Operate this equipment other than as specified by the manufacturer

- Only qualified personnel, physically capable of operating the equipment and with no impairments in their judgment or reaction times, should operate this equipment.
- Read all system component manuals before operating this equipment. A thorough understanding of system components and their operation will help you operate the system safely and efficiently.
- Before starting this equipment, check all safety interlocks, fire-detection systems, and protective devices such as panels and covers. Make sure all devices are fully functional. Do not operate the system if these devices are not working properly. Do not deactivate or bypass automatic safety interlocks or locked-out electrical disconnects or pneumatic valves.
- Protect equipment with safety devices as specified by applicable safety regulations.
- If safety devices must be removed for installation, install them immediately after the work is completed and check them for proper functioning.
- Route electrical wiring along a protected path. Make sure they will not be damaged by moving equipment.
- Never operate equipment with a known malfunction.
- Do not attempt to operate or service electrical equipment if standing water is present.
- Use this equipment only in the environments for which it is rated. Do not operate this equipment in humid, flammable, or explosive environments unless it has been rated for safe operation in these environments.
- Never touch exposed electrical connections on equipment while the power is ON.

Failure to follow these instructions can result in serious injury, death or equipment damage.

1.1.6 Maintenance Safety



DANGER

ELECTRIC SHOCK HAZARD

THIS EQUIPMENT MAY CONTAIN ELECTROSTATIC DEVICES

- DO NOT OPERATE A SYSTEM THAT CONTAINS MALFUNCTIONING COMPONENTS. IF A COMPONENT MALFUNCTIONS, TURN THE SYSTEM OFF IMMEDIATELY.
- DISCONNECT AND LOCK OUT ELECTRICAL POWER.
- ALLOW ONLY QUALIFIED PERSONNEL TO MAKE REPAIRS OR REPLACE MALFUNCTIONING COMPONENTS ACCORDING TO INSTRUCTIONS PROVIDED IN MANUAL.

FAILURE TO FOLLOW THESE INSTRUCTIONS CAN RESULT IN DEATH OR EQUIPMENT DAMAGE

1.1.7 Material Handling Precautions, ESD



CAUTION

Electrostatic Sensitive Devices

This equipment may contain electrostatic devices

- Protect from electrostatic discharge.
- Electronic modules and components should be touched only when this is unavoidable e.g. soldering, replacement.
- Before touching any component of the cabinet you shall bring your body to the same potential as the cabinet by touching a conductive earthed part of the cabinet.
- Electronic modules or components must not be brought in contact with highly insulating materials such as plastic sheets, synthetic fiber clothing. They must be laid down on conductive surfaces.
- The tip of the soldering iron must be grounded.
- Electronic modules and components must be stored and transported in conductive packing.

Failure to follow this instruction can result in equipment damage

1.1.8 Arc Flash and Electric Shock Hazard



DANGER

SERIES CIRCUITS HAVE HAZARDOUS VOLTAGES

THIS EQUIPMENT PRODUCES HIGH VOLTAGES TO MAINTAIN THE SPECIFIED CURRENT - DO NOT DISCONNECT WHILE ENERGIZED.

- ALLOW ONLY QUALIFIED PERSONNEL TO PERFORM MAINTENANCE, TROUBLESHOOTING, AND REPAIR TASKS.
- ONLY PERSONS WHO ARE PROPERLY TRAINED AND FAMILIAR WITH ADB SAFEGATE EQUIPMENT ARE PERMITTED TO SERVICE THIS EQUIPMENT.
- AN OPEN AIRFIELD CURRENT CIRCUIT IS CAPABLE OF GENERATING >5000 VAC AND MAY APPEAR OFF TO A METER.
- NEVER UNPLUG A DEVICE FROM A CONSTANT CURRENT CIRCUIT WHILE IT IS OPERATING; ARC FLASH MAY RESULT.
- DISCONNECT AND LOCK OUT ELECTRICAL POWER.
- ALWAYS USE SAFETY DEVICES WHEN WORKING ON THIS EQUIPMENT.
- FOLLOW THE RECOMMENDED MAINTENANCE PROCEDURES IN THE PRODUCT MANUALS.
- DO NOT SERVICE OR ADJUST ANY EQUIPMENT UNLESS ANOTHER PERSON TRAINED IN FIRST AID AND CPR IS PRESENT.
- CONNECT ALL DISCONNECTED EQUIPMENT GROUND CABLES AND WIRES AFTER SERVICING EQUIPMENT. GROUND ALL CONDUCTIVE EQUIPMENT.
- USE ONLY APPROVED ADB SAFEGATE REPLACEMENT PARTS. USING UNAPPROVED PARTS OR MAKING UNAPPROVED MODIFICATIONS TO EQUIPMENT MAY VOID AGENCY APPROVALS AND CREATE SAFETY HAZARDS.
- CHECK THE INTERLOCK SYSTEMS PERIODICALLY TO ENSURE THEIR EFFECTIVENESS.
- DO NOT ATTEMPT TO SERVICE ELECTRICAL EQUIPMENT IF STANDING WATER IS PRESENT. USE CAUTION WHEN SERVICING ELECTRICAL EQUIPMENT IN A HIGH-HUMIDITY ENVIRONMENT.
- USE TOOLS WITH INSULATED HANDLES WHEN WORKING WITH AIRFIELD ELECTRICAL EQUIPMENT.

FAILURE TO FOLLOW THESE INSTRUCTIONS CAN RESULT IN DEATH OR EQUIPMENT DAMAGE

2.0 Introduction

Ferroresonant L-828 / L-829 Constant Current Regulator

2.1 About this manual

The manual shows the information necessary to:

- Install the CCR
- Carry Out Maintenance
- Carry Out Troubleshooting

2.2 How to work with the manual

1. Familiarize yourself with the structure and content.
2. Carry out the actions completely and in the given sequence.

2.3 CRF Introduction

This section describes the ADB SAFEGATE Ferroresonant, L-828/L-829, constant current regulators (CCRs). These CCRs are manufactured according to FAA specification AC 150/5345-10 (latest edition).



2.4 Constant Current Regulator

Compliance with Standards

FAA: L-828/L-829 AC 150/5345-10 (Current Edition).
ETL Certified.

Uses

FAA L-828/L-829 & ICAO

Provides three or five precision output levels to power series lighting circuits on airport runways and taxiways.

RELIANCE Power ACE3 Unit

The optional RELIANCE Power ACE3 unit provides L-829 monitoring and optional Insulation Resistance and CCR Input Monitoring capability.

- CCR output, current, voltage, VA, watts
- CCR input voltage
- CCR run-time by step
- CCR cycle count

Optional CCR input monitoring adds the following parameters:

- CCR input current
- CCR input power (VA)
- CCR input power (watts)
- CCR input power factor
- CCR % efficiency

The RELIANCE Power ACE3 unit is also a component of ADB SAFEGATE's distributed control and monitoring system. Each unit can be easily connected to an Airport Lighting Control & Monitoring System (ALCMS) by simply adding redundant communication wires. More information can be found on the RELIANCE Power ACE3 data sheet 3097.

Environmental Operating Conditions

Temperature:	L-828: -40°C to +55°C (-40°F to +131°F) L-829: 0°C to +55°C (+32°F to +131°F)
--------------	--

Humidity:	10 to 95%
-----------	-----------

Altitude:	0 to 6,600 ft (2,000 m)
-----------	-------------------------

Power Supply

Power Input:	60 Hz, 1 P, 208 - 600 VAC (-5/+10%) 50 Hz, 1 P, 208 - 400 VAC (-5/+10%)
Power Factor:	0.99 typical*
Efficiency:	90% minimum for 2.5 - 25 kW* 92% minimum for 30 kW*
Remote Control (internally sourced):	120 VAC 50/60 Hz (-5/+10%) +48 VDC (±10%) +24 VDC (±10%)

* At top step with full resistive load.

Weights and Dimensions

CCR Size	Dimensions in (mm) (H x W x D)	CCR Weight lb (kg)	Shipping Weight lb (kg)
2.5 - 10 kW	40 x 24 x 26 (1,016 x 610 x 660)	2.5 kW: 277 (126)	2.5 kW: 317 (145)
		4 kW: 443 (201)	4 kW: 483 (220)
		5 kW: 505 (229)	5 kW: 545 (248)
		7.5 kW: 597 (271)	7.5 kW: 637 (290)
		10 kW: 663 (301)	10 kW: 703 (320)
15 - 30 kW	40 x 31.5 x 31.5 (1,016 x 800 x 800)	15 kW: 755 (342)	15 kW: 795 (361)
		20 kW: 1048 (475)	20 kW: 1088 (494)
		25 kW: 1201 (545)	25 kW: 1241 (564)
		30 kW: 1355 (615)	30 kW: 1395 (634)

Additional Options

Additional options are available to customize CCRs for specific application requirements.

- Output Current Sensing Relay Option: provides a dedicated dry contact closure if CCR output current is present
- Door Documentation Pocket Option: provides a pocket for CCR documentation on the inside of the front door
- Input Circuit Breaker Option: replaces the standard input power fuses with an internally mounted thermal circuit breaker

Not all Additional Options are shown in the ordering code. Please contact ADB SAFEGATE Sales for further information.

2.5 Remote Control Input

120 VAC, +24 VDC, or +48 VDC ($\pm 10\%$)

2.6 Total Harmonic Distortion* (THD)

Current THD: 10% maximum in highest step Voltage THD: 1.9% maximum in all steps

* Tested with 100% resistive load according to FAA AC 150/5345-10 (Latest Edition).

2.7 Theory of Operation Introduction

Ferroresonant transformer used to supply output voltage to the series circuit. Utilizing a feedback current sense, the output voltage is regulated to ensure that a constant current is delivered to the series circuit per FAA regulations. The output voltage is modulated by controlling the current flowing in the tank winding of the ferroresonant transformer.

For more theory of operation see: ["Theory of Operation"](#).

2.8 ACE3 Unit



The ACE3 unit provides L-829 monitoring and optional megging or CCR input monitoring capability. Each unit is installed locally at each CCR that requires remote control and/or monitoring within the airfield lighting electrical vault. Optional CCR input monitoring monitors the following:

- CCR input current
- CCR input voltage
- CCR input volt-amps (VA)
- CCR input power (watts)
- CCR input power factor
- CCR % efficiency

The ACE3 unit is also a component of ADB SAFEGATE's distributed control and monitoring system. Each unit can be easily connected to an Airport Lighting Control & Monitoring System (ALCMS) by simply adding redundant communication wires. See the ADB SAFEGATE ACE3 catalog sheet for additional information. See www.adbsafegate.com.

2.9 CCR Theory of Operation

This subsection describes the Ferroresonant L-828/L-829 CCR theory of operation.

2.9.1 Power Circuit

See [Figure 1](#). A Ferroresonant network consisting of T1, C1, and the SCRs draw from the input lines. This network is capable of drawing a limited amount of power. It can be routed to one of two places. The first is the output leads to the airfield. The second is a resonant tank comprised of Cx and part of T1.

As more power is allowed to flow into the resonant tank, less is available to flow to the field. It is by regulating the current in this tank that the SCRs regulate throughput current to the airfield. It is important to note that the output of the regulator will be the smallest when the SCRs are conducting 100% of the time. This is the opposite of what is seen in SCR type or thyristor regulators where the SCRs are used to directly control the regulator output current.

NOTE: Cx is a bank of capacitors located near T1.

The components of the ferroresonant network are designed to deliver an output current slightly higher than 6.6 A/20 A for the minimum input voltage, while the SCRs are fully off.

2.9.2 Output Measurement

The output current flows through the high voltage current transformer T5. T5 provides feedback to the Control PCB on the actual current output to the airfield series circuit.

On L-828 style regulators, a second current transformer, T2, provides current to a True-RMS-reading ammeter mounted onto the front panel to indicate output current.

2.9.3 URC4 Control PCB

See [Figure 4](#). This subsection describes the board level circuitry found on the Control PCB.

Figure 1: L-828 CCR Power Circuit Block Diagram

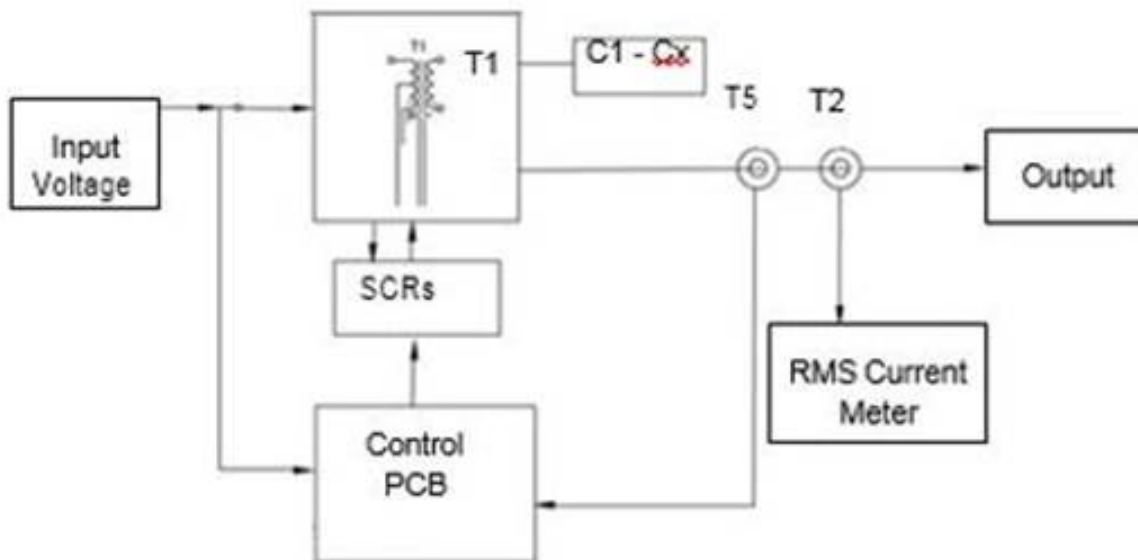

2.9.4 URC4 Control PCB Inputs/Outputs

The Control PCB receives the inputs listed below. See [Figure 5](#) in this section and “[Wiring Schematics](#)”.

- Input from the Local CCR Switch (via Ribbon Cable – J10) for local control and switching of the CCR unit
- Direct communication from the ACE3™ to the URC4 control board for step and monitoring functions
NOTE: No additional hardware required.
- Remote control signals from a remote control terminal block located in the L-828 chassis (120Vac/48Vdc) (TB1 to J8)
- A current proportional to the output current from a current transformer (T5).
- Phase angle reference voltage derived from the input voltage.
- 24 Vac center tapped supply voltage from T4.
- Output voltage feedback winding from T1.

3.0 Theory of Operation

The Control URC4 PCB provides the outputs listed below.

- A contact to complete the input contactor K2 coil circuit. (J12)
- A contact to enable the Remote CCI voltage at TB1. (J9)
- Gate drive signals to the SCR block used to regulate the output current.

3.1 Output Current Monitor Circuitry

The system output current is sensed by a current transformer (T5) whose secondary is connected to J1-3 and J1-4 on the Control PCB. This current signal is passed through a 10-ohm shunt resistor (R108), located on the Control PCB. For the 6.6 amp regulator, T5 provides a 100:1 step-down of the feedback current. For 20 A regulators, this ratio is 300:1. Output current steps 1-5 would correspond to voltage levels of 280, 340, 410, 520 and 660 millivolts respectively.

3.2 Output Current Configuration

The URC4 control PCB allows for ease of calibration of the output current provided by the constant current regulator. Located on the board are three (3) push buttons that provide for INC (increase), DEC (decrease) and SAVE (save) functions. Depressing each corresponding button either raises or lowers the regulators output current using the “save” button to lock in the setting once the desired current levels are reached. This function is done per step of the CCR, which allows for greater flexibility in adjusting current ranges.

3.3 Local Control Switch Operation

Local control position detection is accomplished by using a rotary switch mounted on the front door of the CCR. See Figure 3.

3.4 Contactor Drive

The contactor drive circuit on the Control PCB pulls in the main contactor K2 by connecting 120 Vac (present on J12-1) to J12-3.

3.5 Remote Control Position Detection

When the local control signal to the micro-controller indicates “remote” the remote control circuitry is active. Relay K1 on the Control PCB closes, providing 120VAC or 48 VDC to the CCI connection on TB1 via J9-1 and the door interlock switch. The remote control inputs incorporate surge suppression and are optically isolated from the rest of the PCB.

3.6 Fault Protection

This subsection describes CCR fault protection.

3.6.1 Overcurrent Protection

The micro-controller detects an over current condition by comparing the output current to a preset value. If the output current exceeds this value the controller will shut the regulator down by removing voltage from the input contactor. This contactor will remain de-energized until the controller is reset either by selecting the OFF position (remotely or locally) or cycling the input power off for a minimum of 2 seconds and then back on. The control board will not recognize momentary over currents caused by load switching or other transient conditions.

3.6.2 Open Circuit Protection

The micro-controller detects an open circuit by the absence of current in the regulator output (this will also detect an open or shorted current transformer). If the output current is less than 1 amps, the controller will shut the current regulator down within 2s by removing voltage from the input contactor. This contactor will remain de-energized until the controller is reset either by selecting the OFF position (remotely or locally) or cycling the input power off for a minimum of 2 seconds and then back on.

3.7 L-828 CCR

See Figure 2. This subsection describes the L-828 CCR. The L-828 uses a Control PCB to provide regulator and control functions.

Figure 2: L-828 CCR



Analog Ammeter (shown)

Rotary Switch

The L-828 CCRs are designed to:

- Supply three or five precision output current levels (6.6 A/20 A maximum) to power airport series lighting circuits on runways and taxiways.
- Accurately regulate the output current to within $\pm 1\%$ of the adjustable nominal levels from no load to full load and with input voltage variations of -5% to +10% of nominal.
- Maintain the nominal output current levels even when 30 percent of the isolation transformers in the series lighting circuit supplied by the regulator have open secondaries.

3.8 L-829 CCR

See Figure 3. This subsection describes the L-829 CCR. The L-829 uses a URC4 Control PCB to provide regulator and control functions. See Figure 4.

It also uses the Advanced Control Equipment (ACE3) for control and monitoring functions.

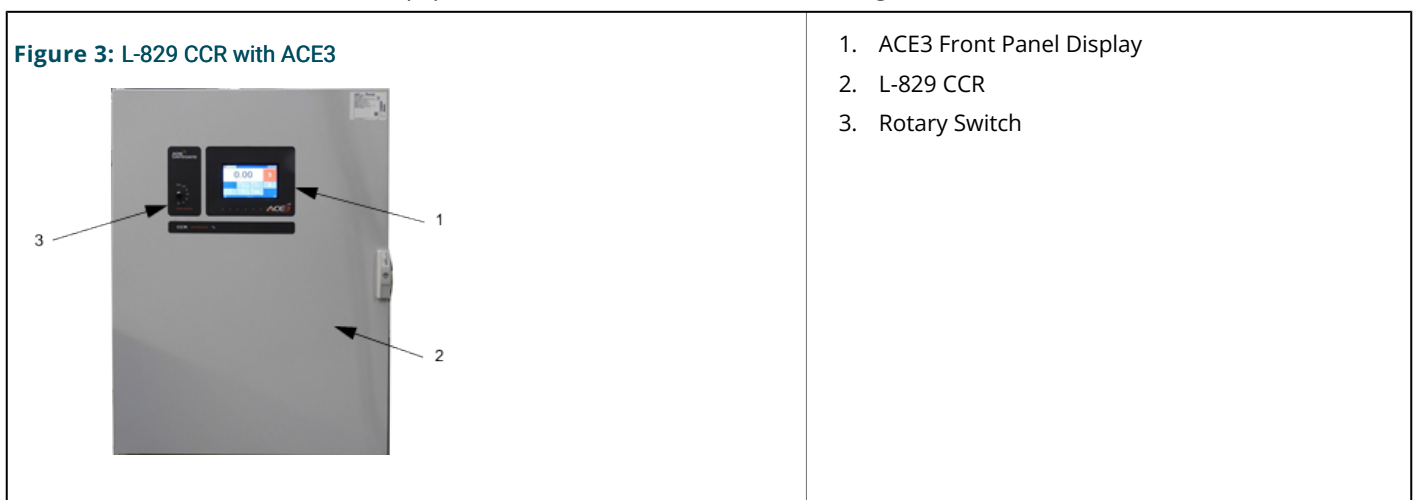

1. ACE3 Front Panel Display
2. L-829 CCR
3. Rotary Switch

3.9 URC4 CCR Controller

The URC4 CCR Controller is an advanced PC board that is designed to provide all regulator and control, monitoring and interface functions to the ACE3™. This is accomplished with a microcontroller and interface circuitry contained on a single 4 x 8 inch (102 mm x 203 mm) through-hole type printed circuit board. The regulator controller PCB performs the functions listed below..

- Produces SCR drive signals in accordance with the desired output current setting.
- Detects an over-current, or open circuit, and switches the constant current regulator off.

- When in Remote mode, enables the CCI to provide 120 Vac at 50 W. The CCI is the Remote power control source.
- Provides direct, real time communication to the ACE3 control and monitoring unit via proprietary protocol

Figure 4: URC4 CCR Controller

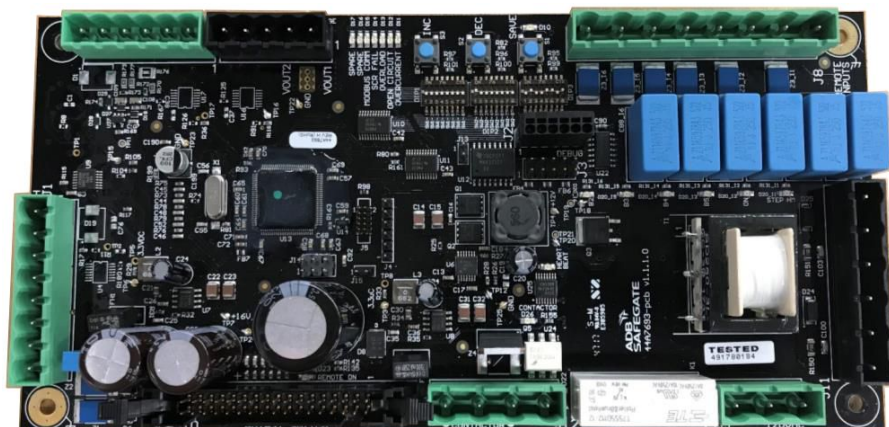

3.9.1 L-829 Advanced Control Equipment

The L-829 ACE3™ control and monitoring unit consists of an integrated control unit that is interfaced to each CCR either internally or within a small external enclosure. The ACE3 printed circuit boards are mounted inside an environmental enclosure that is directly attached to the door of the L-829 CCR.

Figure 5: ACE3 Control Board

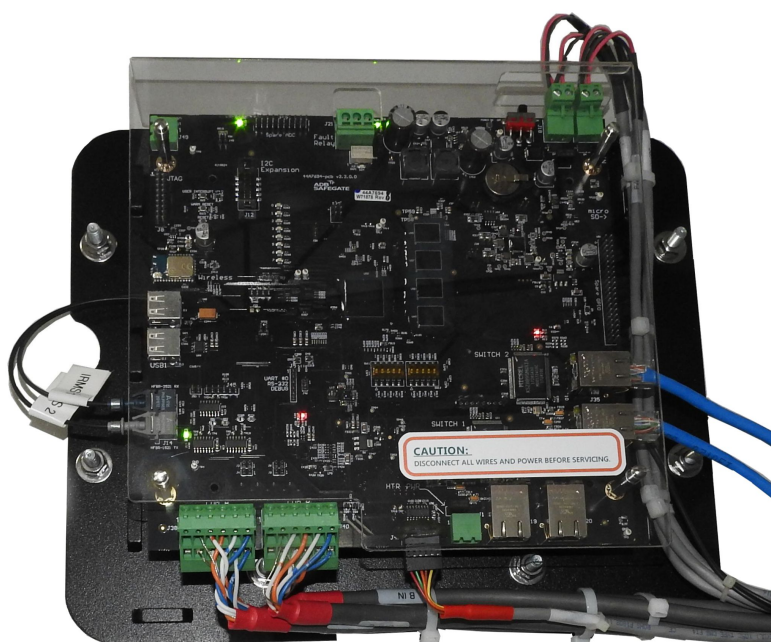

For more information see www.adbsafegate.com

3.10 L-828/L-829 CCR Monitoring Options

The L-829 CCR monitoring options include the Insulation Resistance Monitoring System (IRMS), Lamps out Monitoring for non-LED type airfield circuits and ALCMS Computer or PLC Interface.

3.10.1 Optional Insulation Resistance Monitoring System



CAUTION

When servicing a regulator with an IRMS module, be sure that power to the IRMS is disconnected before touching the IRMS board or any of the high voltage components or wires.

The IRMS is used only on the L-829. It performs scheduled cable insulation resistance measurements and can also perform manually requested measurements. IRMS provides the ability for monitoring the long-term degradation of the airfield series circuit cabling and showing the results on the L-829 CCR front display panel. Utilizing the ACE3 display, all features of the Megging option, from alarm thresholds to Meg on demand can be performed.

3.11 Optional Series Cutout Type SCO

The Series Cutout Type SCO is often used at airports with a large number of series circuits in order to isolate a series circuit from the CCR during maintenance or testing operations. It also allows manual measurement of resistance of the series circuit to ground without disconnecting the series cable. The SCO cutout has a nominal working voltage of 5 kV and a nominal carrying current capacity of 20 amps AC. Two types of SCO can be used: 1475.92.030 or ALSC.

Figure 6: SCO - Series Circuit Cutout, 1475.92.030



Figure 7: SCO - Series Circuit Cutout, ALSC



Note

SCO - Series Circuit Cutout (1475.92.030) includes a micro-switch to detect removal of the SCO handle. The handle can be locked in position and can be placed in the Maintenance or the Test positions, which ground the CCR output and the field cable. Please refer to SCO Cutout manual 96A0294 for more details.

The Series Circuit Cutout (ALSC) does not include a micro-switch. It allows for shorting the CCR output and the field cable. Please refer to SCO Cutout manual 96A0490 for more details.

3.12 Optional Current Clamp Test Point

Regulators without an optional Series Circuit Cutout (SCO) will have a current clamp test point installed to provide a location to attach an output current clamp when used to calibrate the output of the CCR.

3.13 L-828 CCRs Required Equipment

Refer to Table 1 for required equipment that is supplied. Refer to Table 2 for required equipment that is not supplied.

Table 1: Required Equipment Supplied

Description	Quantity
L-828/L-829 constant current regulator	As Req'd on Order
Instruction manual	1 per CCR on Order

Table 2: Required Equipment Not Supplied

Description	Quantity
Input power wire. Refer to Table 3.	As required
Remote control wire, AWG 18 minimum, AWG 14 maximum	As required
Ground wire; 8 AWG minimum	As required
Output load wire, 6-8 AWG, 5000 Vac, L-824 type	As required
Shorting jumper wire, 8 AWG minimum	As required
Disconnect switch or main circuit breaker	1
True RMS Multi-meter with current clamp (rated to measure up to 20 Amps AC)	1
Mounting bolts, 1/2"-13 x 1-1/2" long, 1/2" STD washers, and lock washers	4

NOTE: The SCO (if installed) can also be used to short the output of the CCR.

3.14 Electrical Connections



WARNING

All electrical connections must be made by a qualified electrician! Failure to comply may cause serious injury!



WARNING

Make sure the equipment is properly connected to the grounding conductor to avoid electric shock. When a single point ground system is used in the facility housing the CCR, the CCR's external frame ground should be used to connect the CCR's enclosure to the single point ground system.



CAUTION

This CCR must be grounded in accordance with your local electrical codes and ordinances.



CAUTION

Observe local electrical codes and ordinances when making electrical connections to the CCR.



CAUTION

A separate electrical circuit should be used for each CCR.

3.15 Input Power Breaker Sizing



CAUTION

The supply circuit should be protected with a circuit breaker with an amperage rating slightly higher (e.g., typically 15-25%) than the full load current of the CCR.



CAUTION

Always observe local electrical codes and ordinances when selecting a circuit protection device.



Note

The currents listed in the table below represents input currents assuming the worst case limits of AC 150/5345-10 for low line power factor, efficiency, and the maximum allowable load of open circuited isolation transformers while running at full load and the highest output step.

Table 3: Full Load Input Current

SIZE	208 V	220 V	230 V	240 V	347 V	380 V	400 V	480 V	600 V
2.5 kW	17 A	16 A	15 A	15 A	10 A	9 A	9 A	7 A	6 A
4 kW	27 A	26 A	25 A	24 A	16 A	15 A	14 A	12 A	9 A
5 kW	34 A	32 A	31 A	30 A	20 A	19 A	18 A	15 A	12 A
7.5 kW	51 A	48 A	46 A	44 A	31 A	28 A	27 A	22 A	18 A
10 kW	68 A	65 A	62 A	59 A	41 A	37 A	35 A	30 A	24 A
15 kW	97 A	92 A	88 A	84 A	58 A	53 A	50 A	42 A	34 A
20 kW	129 A	122 A	117 A	112 A	78 A	71 A	67 A	56 A	45 A
25 kW	162 A	153 A	146 A	140 A	97 A	88 A	84 A	70 A	56 A
30 kW	190 A	179 A	172 A	164 A	114 A	104 A	99 A	82 A	66 A

4.0 Specifications

This subsection provides specifications for L-828/L-829 CCR (6.6 A/20 A).

Table 4: Class, Style and Power Ratings

Class	L-828/L-829 CCR Max Output Current	Style	Brightness Steps	Nominal Output Current	Power Ratings
1	6.6 A	1	3	4.8 A, 5.5 A, 6.6 A	2.5 - 30 kW
		2	5	2.8 A, 3.4 A, 4.1 A, 5.2 A, 6.6 A	
2	20 A	2	5	8.5 A, 10.3 A, 12.4 A, 15.8 A, 20 A	15 - 30 kW

Table 5: Power Factor

CCR	Power Factor ¹
2.5 - 10 kW	0.90 minimum
15 -30 kW	0.95 minimum

4.1 Efficiency

Table 6: Efficiency

CCR	Efficiency ²
2.5 - 25 kW	90% minimum
30 kW	92% minimum

4.2 Output Current Regulation

The CCR maintains its output current within the limits of table below as defined in FAA AC 150/5345-10 (latest edition). The FAA specification addresses resistive loads between no load (short circuit) to the full CCR rating along with reactive loads consisting of resistive loads connected via isolating transformers with the secondaries of 30 percent of the transformers open-circuited. The reactive load (before opening the isolation transformer secondaries) may be any value from half to the full CCR rating.

Table 7: Output Current and Limits

Class	Style	Step	Nominal output amperes (A) root mean square (RMS)	Allowable range (A RMS)
1	1	B100	6.6	6.5 - 6.7
		B30	5.5	5.4 - 5.6
		B10	4.8	4.7 - 4.9
1	2	B5	6.6	6.5 - 6.7
		B4	5.2	5.1 - 5.3
		B3	4.1	4.0 - 4.2
		B2	3.4	3.3 - 3.5
		B1	2.8	2.7 - 2.9
2	2	B5	20.0	19.7 - 20.3
		B4	12.8	15.5 - 16.1
		B3	12.4	12.1 - 12.7

¹The power factor of the regulator operated at rated input voltage running at step B5/B100 into a full load having unity power factor is not less than the value shown.

²The efficiency of the regulator operated at rated input voltage running at step B5/B100 into a full load having unity power factor is not less than the value shown.

Table 7: Output Current and Limits

Class	Style	Step	Nominal output amperes (A) root mean square (RMS)	Allowable range (A RMS)
		B2	10.3	10.0 - 10.6
		B1	8.5	8.2 - 8.8

4.3 Protection Devices

L-828 & L-829 CCRs have the following protection devices:

- Output open-circuit protection.
- Output overcurrent protection.
- Lightning arrestors on output terminals and bushings.
- Lightning arrestors on input terminals.
- Fuse protection of AC supply voltage of the Control PCB and brightness control voltage for Remote control.

4.4 Open-Circuit Protection

The regulator includes an open-circuit protective device to open the primary switch within 2 seconds after an open circuit occurs in the secondary. The device resets within 2 seconds after the control switch is turned to the OFF position.

4.5 Overcurrent Protection

Regulators include an overcurrent protective device that opens the primary switch when the output current exceeds the 100 percent current (6.6 A or 20 A) by 5 percent. The device operates within 5 seconds after an overcurrent of 5 percent and within 1 second after an overcurrent of 25 percent. The device resets within 2 seconds after the control switch is turned to the OFF position.

4.6 Input Voltage

Input voltage is single phase 50 or 60 Hz AC. Regulators operate as required (see Output Current Regulation section) with input voltage between 95 and 110 percent of the nominal value. The regulator is designed to withstand momentary voltages up to 120 percent of nominal input voltage without shutting off or being damaged so long as the duration of overvoltage excursions are not longer than 50 milliseconds and do not occur more than once per minute.

4.7 Built-In True-RMS Ammeter (L-828 only)

For the L-828 only, a flush-mounted analog True-RMS ammeter mounted on the front of the regulator indicates the output current.

4.8 Input Power Monitoring Option via ACE3™

When supplied with an ACE3™, an optional input power monitoring function is available. Input power measurements can be displayed on the ACE3™ or incorporated into an ALCMS system. The option consists of adding a current transformer properly sized to the rating of the CCR that will interface to the URC4 CCR Controller PCB. When interfaced to an ACE3™ unit in conjunction with an ALCMS system, real time input monitoring and alarm recording is available.

5.0 Installation

This section provides instructions for installing L-828/L-829 constant current regulators (CCRs). Refer to the airport project plans and specifications for the specific installation instructions.

5.1 Introduction to Safety



CAUTION

Unsafe Equipment Use

This equipment may contain electrostatic devices, hazardous voltages and sharp edges on components

- Read installation instructions in their entirety before starting installation.
- Become familiar with the general safety instructions in this section of the manual before installing, operating, maintaining or repairing this equipment.
- Read and carefully follow the instructions throughout this manual for performing specific tasks and working with specific equipment.
- Make this manual available to personnel installing, operating, maintaining or repairing this equipment.
- Follow all applicable safety procedures required by your company, industry standards and government or other regulatory agencies.
- Install all electrical connections to local code.
- Use only electrical wire of sufficient gauge and insulation to handle the rated current demand. All wiring must meet local codes.
- Route electrical wiring along a protected path. Make sure they will not be damaged by moving equipment.
- Protect components from damage, wear, and harsh environment conditions.
- Allow ample room for maintenance, panel accessibility, and cover removal.
- Protect equipment with safety devices as specified by applicable safety regulations
- If safety devices must be removed for installation, install them immediately after the work is completed and check them for proper functioning prior to returning power to the circuit.

Failure to follow these instructions can result in serious injury, death or equipment damage

Additional Reference Materials



Important Information

- IEC – International Standards and Conformity Assessment for all electrical, electronic and related technologies.
- IEC 60364 – Electrical Installations in Buildings.
- CSA – C22.2 No.180:13 (R2018), series isolating transformers for airport lighting.
- FAA Advisory: AC 150/5340-26 (current edition), Maintenance of Airport Visual Aid Facilities.
- Maintenance personnel must refer to the maintenance procedure described in the ICAO Airport Services Manual, Part 9.
- ANSI/NFPA 79, Electrical Standards for Metalworking Machine Tools.
- National and local electrical codes and standards.

5.2 Unpacking

The equipment is shipped ready for installation. Handle equipment very carefully to prevent component damage. Unpack the carton upon receipt and check the contents and their condition. Note any exterior damage to the carton that might lead to detection of equipment damage.

If you note any damage to any equipment, file a claim with the carrier immediately. The carrier may need to inspect the equipment.



Note

Take care to maintain the unit in an upright position when handling the regulator.

5.2.1 Material Handling Precautions : Storage



CAUTION

Improper Storage

Store this equipment properly

- If equipment is to be stored prior to installation, it must be protected from the weather and kept free of condensation and dust.

Failure to follow this instruction can result in equipment damage

5.3 Installation Overview



CAUTION

Place the regulator inside a well ventilated room with sufficient clearance for personnel to inspect and maintain the unit. Maintain a good air flow around the CCR.

Installation and operation of the CCR should be performed by personnel qualified to work on high voltage equipment. The high voltage involved with the unit makes it potentially dangerous and may be lethal if contacted by operating personnel.

Place wiring for output, input, and remote control only on the right side of the CCR to prevent damage to the PCB that is located on the front Left side of the enclosure.

If output, input, and remote control wiring must enter from the left side of the enclosure then wiring must be then routed through conduit where it passes the PCB area. See Figure 6.



CAUTION

The recommended lifting method for the regulators is to use a forklift from underneath the CCR frame. Four 3/4-inch ID lifting eye-bolts on the top corners of the CCR frame are provided per FAA specifications. If lifting eye-bolts are used, use either a portable hoist and sling(s) or sling(s) attached from forks on forklift. Check Dimensions and Weights table before lifting.

Table 8: Clearance specifications

Clearance specification	Distance [mm]
Front clearance	Approximately 500
Between the rear of the machine and the wall, X	Approximately 500
Between two machines (side by side), or between another machine, Y	Minimum 150

If necessary, the distances can be increased for maintenance purposes.

5.3.1 Mounting Information

This section contains information about mounting the CCR.

The mounting bolt/anchor holes are for a 3/8" diameter bolt/anchor.

Mounting bolt pattern:

- 2.5-10kW: 20.5" W x 19.0" D
- 5-30kW: 28.0" W x 25.0" D

5.3.2 Stacking Information



CAUTION

When stacking ADB SAFEGATE regulators, the bottom regulator must be bolted to a concrete mounting pad.

Stacking two CRF or CRT regulators of the same frame size:

CRF and CRT regulators can be stacked to minimize floor space requirements. CRT and CRF of the same frame size can stack directly on top of each other with no need for additional supports. An air deflector is required between CCRs. The kits below include the hardware to secure the stacked CCRs to each other along with an air deflector to direct the flow of hot air exiting the bottom CCR to the rear while allowing ambient air in from the front to the top CCR. Stacking is limited to CRF or CRT of the same frame width and is limited to a maximum of two (2) regulators high with a stack height of approximately 80 inches OAH.

CRF or CRT Frame Width	Stacking Kit Part Number
24 inches	AK00021-100-01
31.5 inches	AK00021-200-01

To stack two CRF or CRT regulators of the same frame size, complete the following steps (refer to figure below):

1. If installed, remove the four (4) lifting eye-bolts from the top of the LOWER regulator. Save these bolts for future use if you need to move the CCR.
2. Using a proper lifting device, carefully lift the UPPER regulator using its lifting eye-bolts and set it on the LOWER regulator, lining up the four (4) mounting holes.
3. Install two (2) of the supplied 3/8"-16 x 3/4" hex head bolts, flat washers, and split washers into the two (2) rear corners of the stacked regulators, securing the UPPER and LOWER regulators together. Fully install these bolts, but do not torque to final setting.
4. Insert the Air Deflector (ITEM 1 below) between the two regulators through the front of the regulator stack, lining the bolt holes of the Air Deflector over the two (2) front mounting holes in the front corners of the regulators. The Air Deflector should angle up toward the rear of the regulators.
5. Install two (2) of the supplied 3/8"-16 x 3/4" hex head bolts, flat washers, and split washers (ITEMS 2, 3, 4 below) into the two (2) front corners, securing the Air Deflector and the UPPER and LOWER regulators together. Install these bolts approximately halfway, allowing the rear of the air deflector to drop down slightly.
6. While continuing to support the UPPER regulator from its lifting eye-bolts, remove the two (2) rear bolts (and their mounting hardware) that attach the upper side of the mounting feet to the bottom of the UPPER regulator frame. Reinstall these two (2) bolts (with their mounting hardware) through the two rear holes of the Air Deflector and then back into their original installation holes in the bottom of the UPPER regulator frame. Torque these two bolts to 230 in-lbs (26 n-m).

- Torque all four (4) 3/8"-16 x 3/4" hex head bolts used to mount the UPPER regulator feet to the LOWER regulator frame to 230 in-lbs (26 n-m).

Figure 8: Side view of stacked CRF or CRT regulators.

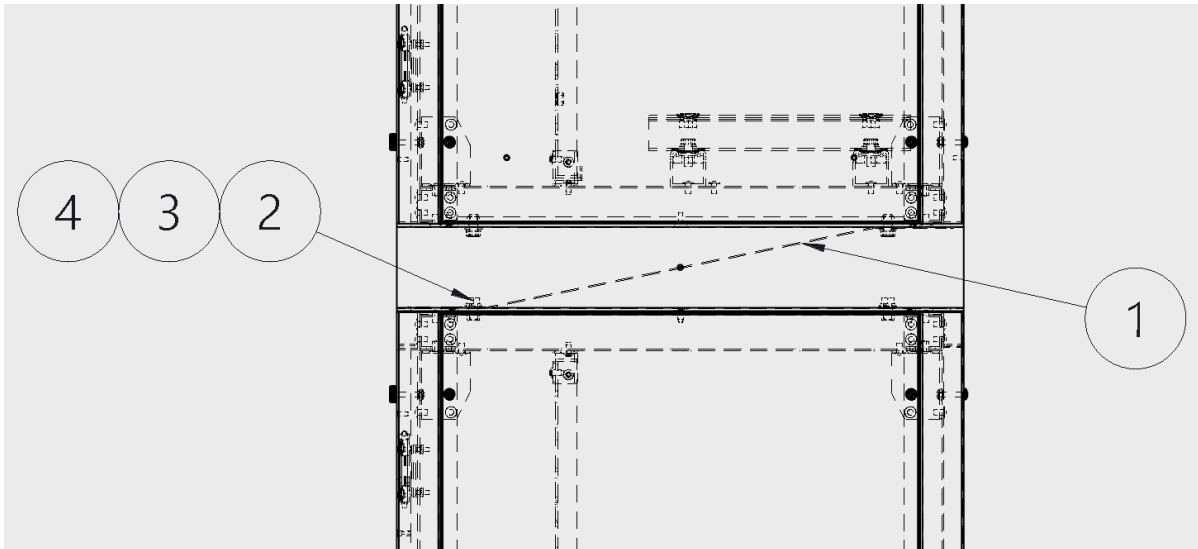

Stacking CRF or CRT regulators on top of previous ADB SAFEGATE regulator designs:

CRT and CRF can be stacked with most older ADB SAFEGATE regulators. The stacking kits below allow an ADB SAFEGATE CRF or CRT regulator to be stacked on top of ADB SAFEGATE CSF, CCT, CHF, and CCF regulators. The LOWER regulator MUST BE OF THE SAME FRAME SIZE OR LARGER than the UPPER regulator. The kits below also allow the stacking of a CRF or CRT with a 24 inch wide frame to be stacked on top of a CRF or CRT with a 31.5 inch frame. An Air Deflector is required between CCRs that must be sized for the UPPER regulator's frame width. The kits below include the uni-strut and hardware to secure the stacked CCRs to each other along with an Air Deflector to direct the flow of hot air exiting the bottom CCR to the rear while allowing ambient air in from the front to the top CCR. The uni-strut can be cut at installation to match the size of the lower regulator. Stacking is limited to a maximum of two (2) regulators high. These stacking kits add approximately 3 inches to the OAH of the regulator stack.

UPPER Regulator Frame Width	Stacking Kit Part Number
24 inch	AK00033-100-01
31.5 inch	AK00033-200-01

To stack a CRF or CRT regulator on top of an ADB SAFEGATE CSF, CCR, CHF, or CCF regulator complete the following steps:

- Before installing anything onto the regulators, pre-build the assembly shown in the figure below with the included hardware. Tighten all hardware so you can easily adjust the alignment of the parts. It is recommended that you measure the UPPER regulator mounting holes from front to back and side to side and adjust the upper two uni-strut rails so they are close to these dimensions prior to proceeding. Install four (4) of the uni-strut spring-loaded nuts into the upper two (2) rails in approximately the location of your upper regulator's mounting holes.
- If installed, remove the four (4) lifting eye-bolts from the top of the LOWER regulator. Save these bolts for future use if you need to move the CCR.
- Set the assembly built in Step 1 onto the top of the LOWER regulator with the lower uni-strut rails running along the sides of the LOWER regulator.
- Align the two bottom uni-strut rails over the mounting holes on the top of the LOWER regulator frame, aligning the entire assembly on the regulator frame. Mount the assembly to the LOWER regulator with the four (4) supplied 1/2"-13 x 1 1/4" hex head bolts, split washers, and flat washers. Torque these four (4) bolts to 230 in-lbs (26 n-m).
- Using a proper lifting device, carefully lift the UPPER regulator using its lifting eye-bolts and set it on the upper two uni-strut rails, align the upper uni-strut rails with the four (4) mounting holes on the feet of the UPPER regulator. The four spring-loaded nuts should line up directly under the four (4) mounting holes of the feet of the UPPER regulator.
- Install two (2) of the supplied 3/8"-16 x 3/4" hex head bolts, flat washers, and split washers into the two (2) rear mounting holes of the UPPER regulator, securing it to the stacking frame. Fully install these bolts, but do not torque to final setting.

7. Insert the Air Deflector under the UPPER regulator, on top of the UPPER regulator's mounting feet, through the front of the regulator stack. Line up the bolt holes of the Air Deflector over the two (2) front mounting holes in the front corners of the UPPER regulator mounting feet. The Air Deflector should angle up toward the rear of the regulators.
8. Install two (2) of the supplied 3/8"-16 x 3/4" hex head bolts, flat washers, and split washers through the Air Deflector mounting holes, through the two (2) front mounting holes of the UPPER regulator and then into the spring-loaded nuts installed into the upper uni-strut rail. Install these bolts approximately halfway, allowing the rear of the Air Deflector to drop down slightly.
9. While continuing to support the UPPER regulator from its lifting eye-bolts, remove the two (2) REAR bolts (and their mounting hardware) that attach the UPPER side of the mounting feet to the bottom of the UPPER regulator. Reinstall these two (2) bolts (with their mounting hardware) through the two rear holes of the Air Deflector and then back into their original installation holes in the bottom of the UPPER regulator. Torque these two bolts to 230 in-lbs (26 n-m).
10. Torque all four (4) 3/8"-16 x 3/4" hex head bolts used to mount the UPPER regulator feet to the LOWER regulator to 230 in-lbs (26 n-m).
11. Torque all four (4) 3/8"-16 x 3/4" hex head bolts used to mount the upper uni-strut rail to the bottom uni-strut rail to 230 in-lbs (26 n-m).

5.4 Installation - Wiring the CCR



CAUTION

Read installation instructions in their entirety before starting installation.
Incorrect wiring can damage regulator. Double check all connections.

Figure 9: Recommended Conduit interface Locations

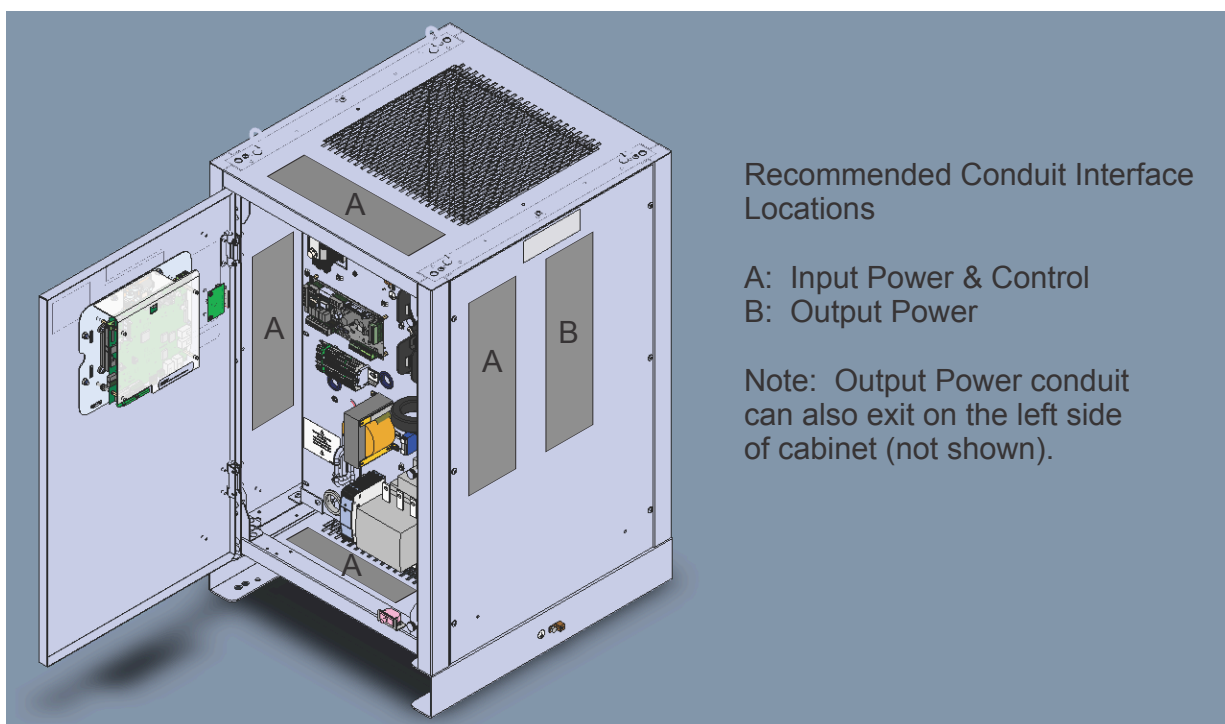

To wire the CCR, perform the following procedure:

1. Verify the input supply voltage corresponds to the voltage rating on the nameplate of the regulator.
2. Make sure the front panel rotary selector switch is set to the OFF position.

3. Ground the regulator by making an adequate ground wire (AWG 6 or larger) connection to the external earth ground lug on the regulator.
4. An appropriate disconnect-type cutout or circuit breaker shall be provided outside the regulator for the input power supply lines.
5. Short-circuit the output terminals VR1 and VR2 using 6 AWG minimum wire to avoid lamp destruction in case of excessive current output. Alternately, if present, the SCO cutout may be used for shorting the output.
6. Refer to the [Input Wire Size](#) section for the recommended input wire. Connect the power supply lines from the disconnect switch or main circuit breaker to the CCR input fuse block F1 and F2 (or CCR input circuit breaker, if present). Tighten all connections.
7. Engage main circuit breaker or disconnect switch to energize the regulator.
8. Turn front panel rotary selector switch locally to all brightness steps, and verify that current values on the panel ammeter or ACE3 display correspond to those in the [Output Current Regulation](#) section for each brightness step.
9. Turn the rotary selector switch to OFF.
10. Disengage the main current breaker or disconnect switch to de-energize the regulator.
11. If multi-wire remote control is being used to control the CCR, connect the remote control lines to remote control terminal block TB1. Use #12-20 AWG, 300-600 V wire. See [Figure 42](#) and [Table 9](#), [Table 10](#), and [Table 11](#) for remote control connections.
12. Energize regulator and set rotary selector switch to REM. Operate the CCR by remote control, and verify correct current levels are obtained on all brightness steps.
13. Turn rotary selector switch to OFF and de-energize regulator (disengage disconnect switch or main circuit breaker). Remove short-circuit link between output terminals VR1 and VR2.
14. Connect the 6.6 A or 20 A series lighting circuit to the appropriate CCR output terminals, see [Table 12](#).



Note

When connecting the series circuit output wires to VR1 and VR2, the output wires shall be terminated with a crimp-on style, tin-plated copper, 7/16-inch ring terminal. The crimp shall be made in accordance with the ring terminal manufacturer instructions.

15. Energize the regulator and re-verify that the current levels are correct in all steps.



Note

If the ADB SAFEGATE Advanced Control Equipment (ACE3) is used with the CRF for remote control from an ALCMS, refer to the Advanced Control Equipment manual for wiring connections to remote control. Table 9 through Table 11 provide the necessary connections for the remote control (either 120 Vac or, +48Vdc). If the ACE3 is used to control the CRF, Terminal T1 does not need to be wired for remote control.

Table 9: Remote Control Connections (3-Step/6.6 A)

For this remote intensity step...	Connect CCI to...
B10 (4.8 A)	CC
B30 (5.5 A)	CC, B30
B100 (6.6 A)	CC, B100
OFF	Not applicable

Table 10: Remote Control Connections (5-Step/6.6 A)

For this remote intensity step...	Connect CCI to...
B1 (2.8 A)	CC
B2 (3.4 A)	CC, B2
B3 (4.1 A)	CC, B3
B4 (5.2 A)	CC, B4
B5 (6.6 A)	CC, B5
OFF	Not applicable

Table 11: Remote Vac Control Connections (5-Step/20 A)

For this remote intensity step...	Connect CCI to...
B1 (8.5 A)	CC
B2 (10.3 A)	CC, B2
B3 (12.4 A)	CC, B3
B4 (15.8 A)	CC, B4
B5 (20 A)	CC, B5
OFF	Not applicable



Note

If more than one intensity command is connected, the CCR will activate at the highest intensity selected.

Table 12: Input/Output Connections

Series Cutout Option	Input Location	Output Location
With Series Cutout	Top of each Input Fuse Block or Circuit Breaker (if installed) on the front top right of the component plate.	Bottom of Series Cutout, see user manual: SCO 96A0294 or ALSC 96A0490.
Without Series Cutout		Lightning Arrestors (VR1 and VR2) on back of the component plate. Ensure a proper connection assembly by installing the ring terminals first against the lightning arrestor, then the flat washer, then the Belleville washer (cupped towards the lightning arrestor), and the 7/16-inch brass nut. Torque to 26 lb/ft (35.3 Nm).

6.0 Operation

This section describes the proper operation of the Ferroresonant CCR and steps needed to setup proper operation when needed.

This section also provides the operational procedures listed below for the L-828/L-829 constant current regulator (CCR).

- CCR control procedures
- CCR shutdown procedures
- CCR adjustment procedures
- SCO Cutout working positions

6.1 Operation Safety



CAUTION

Improper Operation

Do Not Operate this equipment other than as specified by the manufacturer

- Only qualified personnel, physically capable of operating the equipment and with no impairments in their judgment or reaction times, should operate this equipment.
- Read all system component manuals before operating this equipment. A thorough understanding of system components and their operation will help you operate the system safely and efficiently.
- Before starting this equipment, check all safety interlocks, fire-detection systems, and protective devices such as panels and covers. Make sure all devices are fully functional. Do not operate the system if these devices are not working properly. Do not deactivate or bypass automatic safety interlocks or locked-out electrical disconnects or pneumatic valves.
- Protect equipment with safety devices as specified by applicable safety regulations.
- If safety devices must be removed for installation, install them immediately after the work is completed and check them for proper functioning.
- Route electrical wiring along a protected path. Make sure they will not be damaged by moving equipment.
- Never operate equipment with a known malfunction.
- Do not attempt to operate or service electrical equipment if standing water is present.
- Use this equipment only in the environments for which it is rated. Do not operate this equipment in humid, flammable, or explosive environments unless it has been rated for safe operation in these environments.
- Never touch exposed electrical connections on equipment while the power is ON.

Failure to follow these instructions can result in serious injury, death or equipment damage.

6.2 CCR Control Procedures

This subsection describes the regulator operations in local and remote controls.

6.2.1 Local Control

See Switch (3-Step/5-Step). Refer to Output Current Tables below for output current when using local control. The front panel rotary selector switch is used for regulator local control. The rotary switch for the 3-step CCR has five positions; the rotary switch for the 5-step has seven positions. The regulator automatically maintains the output current within $\pm 1\%$ of the nominal value for the brightness position selected.

Figure 10: Switch (3-Step/5-Step)

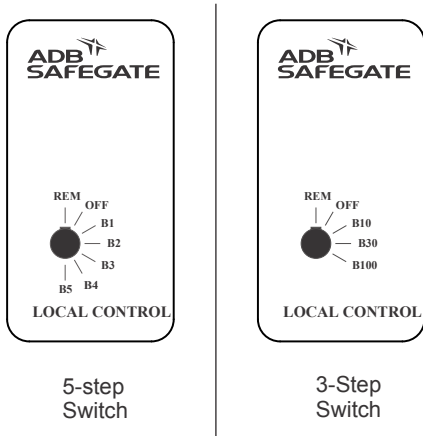

Table 13: Output Current from Rotary Switch (3-Step/6.6A)

If you set the rotary switch to the following...	The result is...
B10	4.8 A current output
B30	5.5 A current output
B100	6.6 A current output

Table 14: Output Current from Rotary Switch (5-Step/6.6 A)

If you set the rotary switch to the following...	The result is...
B1	2.8 A current output
B2	3.4 A current output
B3	4.1 A current output
B4	5.2 A current output
B5	6.6 A current output

Table 15: Output Current from Rotary Switch (5-Step/20 A)

If you set the rotary switch to the following...	The result is...
B1	8.5 A current output
B2	10.3 A current output
B3	12.4 A current output
B4	15.8 A current output
B5	20 A current output

6.2.2 Remote Control

See Remote Control Table for instructions on how to set up and use the CCR remote control.

Table 16: Remote Control

If...	Then...
The rotary switch is set to position REM and remote control wiring is connected to remote control terminal block TB1 on the regulator	Remote control of the regulator is possible. The output current of the regulator will correspond to the brightness setting energized by remote 120 Vac or 48 Vdc control signals.
Switch is set to OFF	Remote control signals will not operate the regulator; that is, turn the regulator on to a particular brightness setting or turn the regulator off.
No remote control connections exist on terminal block TB1 (switch is set to REM)	The position REM becomes an additional OFF position; that is, the regulator is de-energized.

6.2.3 CCR Door Interlock

The door interlock disables remote and local control of the CCR when the door is opened. If the door is opened while the CCR is running, the CCR will shut OFF.

This is to protect personnel from coming into contact with high voltage.

NOTE: Power to the output terminals is now off, and the regulator cannot be energized by remote control signals.



CAUTION

Power is still present on the input power terminals and on the internal control circuitry.

To bypass the interlock, pull out the plunger of the interlock switch. This will allow remote and local control of the CCR with the door open.

6.2.4 CCR Shutdown Procedure

See Figure in Local Control. To shut down the CCR, set the rotary switch to position OFF.

NOTE: Power to the output terminals is now off, and the regulator cannot be energized by remote control signals.



CAUTION

Caution Power is still present on the input power terminals and on the internal control circuitry.

To remove input power, disengage disconnect switch or external circuit breaker.

6.3 CCR Adjustment Procedures

This subsection provides regulator adjustment procedures.



Note

The regulator has been adjusted at the factory to provide the nominal output current levels as given in [Table 13](#), [Table 14](#) and [Table 15](#). If the current level settings need to be adjusted, read the following warning statement before proceeding.



CAUTION

Read the instructions in their entirety before starting calibration procedures.

Only personnel qualified to work on high voltage systems should attempt to make any adjustments on the constant current regulator.

Turn the rotary selector switch on the front panel of the regulator to position OFF. Remove input power before servicing control circuitry.

Never service the regulator when it is in protective shutdown mode, Remote controls or power fluctuations can restart the regulator.

To adjust the output current, perform the following procedure:

1. Connect a clamp-on true RMS reading instrument (such as a Fluke 87 multimeter with a current clamp) around one of the output current leads. See Figure 24.
2. If the optional current clamp test point is present the clamp-on instrument on the CCR component plate should be utilized.

Figure 11: Output Current Clamp

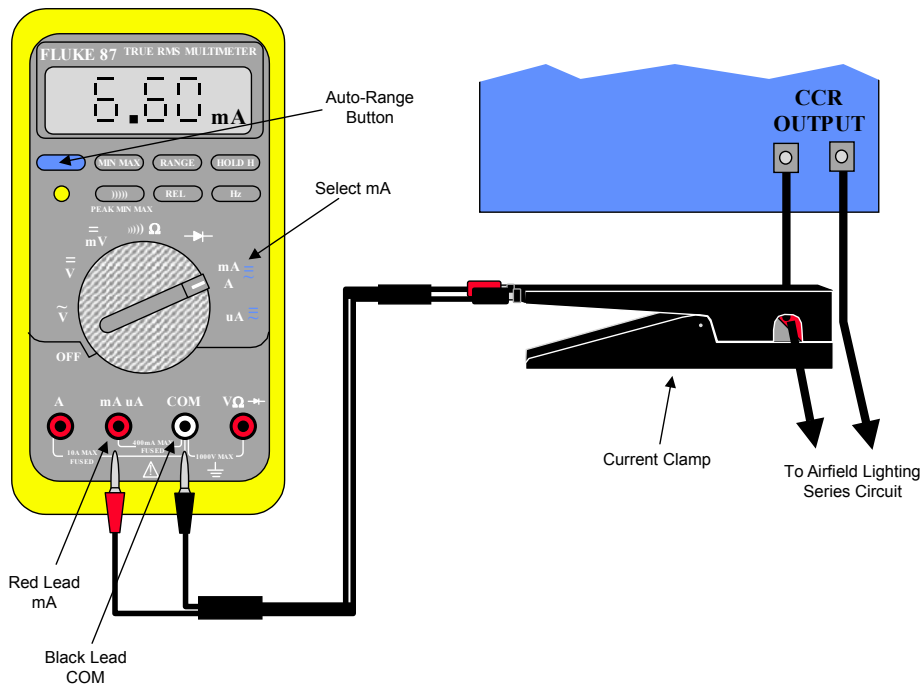

Note

Make sure the meter is set on the AC current scale.

Because the output current waveform is not a true sine wave, the ammeter must be of the True-RMS (root mean squared) type. Field instruments such as clamp-on ammeters and Simpson voltmeters will give erroneously low readings.

6.3.1 Adjusting Output Current (no ACE3)



Note

Output current adjustments on regulators with ACE3 must be done from the ACE3 touchscreen display (see the ACE3 manual 96A0500 in our product center at www.adbsafegate.com).

Figure 12: Regulator URC4 Control PCB

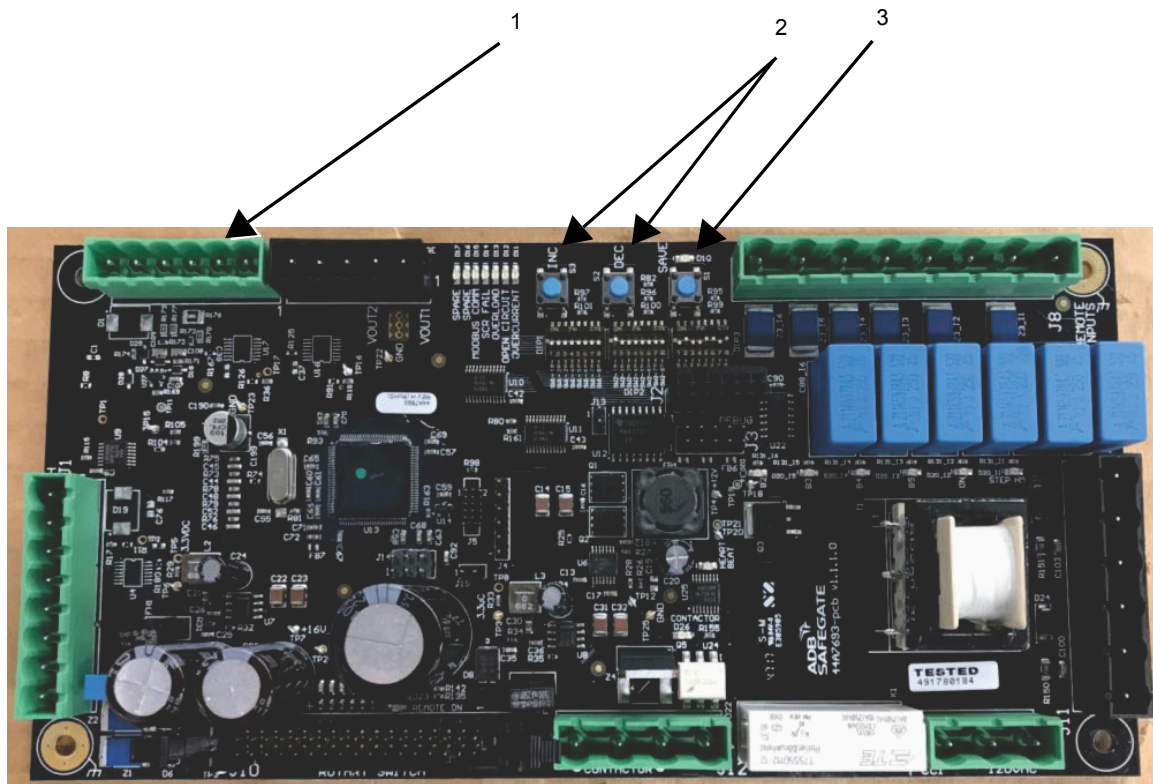

To adjust the output current of Regulator Control Board, perform the following procedure:

1. For 3-step operation, verify that DIP switch Bank 1 Position 2 is ON. For 5-step operation, verify that DIP switch Bank 1 Position 2 is OFF.
 2. Turn on the CCR and set local control switch to the highest intensity step, B5 for 5-step CCR, B100 for a 3-step CCR.
 3. The external True-RMS ammeter should read 6.60 ± 0.1 amps or 20 ± 0.3 amps for 20A regulators. If the reading is outside of this range, adjust the output current with buttons INC and DEC (Figure 12, Item 2) on the Control PCB until the correct current is obtained. Press and hold the SAVE button (Figure 12, Item 3) for two seconds to save the setting.
 4. Turn off the CCR. Remove the short from the output and apply the field load.
 5. Again, turn on the CCR and set local control switch to the highest intensity step, B5 for 5-step CCR, B100 for a 3-step CCR.
 6. The external True-RMS ammeter should read 6.60 ± 0.1 amps or 20 ± 0.3 amps for 20A regulators. If the reading is outside of this range, adjust the output current with buttons INC and DEC (Figure 12, Item 2) on the Control PCB until the correct current is obtained. Press and hold the SAVE button (Figure 12, Item 3) for two seconds to save the setting.
- NOTE:** Each CCR output current step is independently adjustable and must be independently saved.
7. Set the local switch to next to the lowest brightness step, and verify that the True-RMS ammeter reading corresponds to current tables.
 8. If the reading is not in the current value range given in the Tables, adjust the appropriate step until the correct current value is obtained.

9. Repeat Step 2 for the remaining lower brightness step(s).

When the output current adjustment has been completed, turn off the CCR.

6.3.2 Adjusting Over-Current Detection Set Point (no ACE)



Note

Over-current set point adjustments on regulators with ACE3 must be done from the ACE3 touchscreen display (see the ACE3 manual 96A0500 in our product center at www.adbsafegate.com). Any adjustment made to the URC4 control board will be overridden by the ACE3.



Note

Before adjusting the Over-Current Detection point, set up the regulator and adjust the output current per the **ADJUSTING THE CCR OUTPUT CURRENT** section.



Note

The Over-Current setting is pre-set and should normally not need to be adjusted.

To adjust the overcurrent, perform the following procedure:

1. Turn off the CCR to ensure there is no output current to the field.
 2. Short the output of the CCR so the field load cannot be damaged by an over current situation during the adjustment.
 3. Set DIP switch Bank 1 Position 3 to ON for adjusting the 105% overcurrent set point. To adjust the 125% overcurrent set point set DIP switch Bank 1 Position 3 to OFF and 4 to ON.
 4. Turn on the CCR and set the local switch to the highest brightness step, B5 for 5-step CCR, B100 for a 3-step CCR. The True-RMS ammeter should read 6.93 amps or 21 amps for 20A regulators. When adjusting the 125% set point the current should read 8.25 amps or 25 amps for 20A regulators.
-



Note

The SAVE LED (Figure 12, Item 3) will light when you are in the Over-Current Adjustment

The CCR output current will increase to the level previously set as the Over-Current set point. This will be above 6.6 amps.

5. Press the INC or DEC buttons (Figure 12, Item 2) until you reach the desired Over-Current detection set point.
6. Press and hold the SAVE button (Figure 12, Item 3) for two seconds to save the setting.
7. Ensure the DIP switches Bank 1 Position 3 and Position 4 are OFF.
8. Turn off the CCR to ensure there is no output current to the field.
9. Remove the short from the CCR output and apply the field load.

6.4 SCO Operation

This subsection provides the SCO cutout working positions.



DANGER

ARC FLASH AND ELECTRIC SHOCK HAZARD

ALLOW ONLY QUALIFIED PERSONNEL TO PERFORM MAINTENANCE, TROUBLESHOOTING, AND REPAIR TASKS.

- ONLY PERSONS WHO ARE PROPERLY TRAINED AND FAMILIAR WITH ADB SAFEGATE EQUIPMENT ARE PERMITTED TO SERVICE THIS EQUIPMENT.
- AN OPEN AIRFIELD CURRENT CIRCUIT IS CAPABLE OF GENERATING >5000 VAC AND MAY APPEAR OFF TO A METER.
- NEVER UNPLUG A DEVICE FROM A CONSTANT CURRENT CIRCUIT WHILE IT IS OPERATING. ARC FLASH MAY RESULT.
- DISCONNECT AND LOCK OUT ELECTRICAL POWER.
- ALWAYS USE SAFETY DEVICES WHEN WORKING ON THIS EQUIPMENT.
- FOLLOW THE RECOMMENDED MAINTENANCE PROCEDURES IN THE PRODUCT MANUALS.
- DO NOT SERVICE OR ADJUST ANY EQUIPMENT UNLESS ANOTHER PERSON TRAINED IN FIRST AID AND CPR IS PRESENT.
- CONNECT ALL DISCONNECTED EQUIPMENT GROUND CABLES AND WIRES AFTER SERVICING EQUIPMENT. GROUND ALL CONDUCTIVE EQUIPMENT.
- USE ONLY APPROVED ADB SAFEGATE REPLACEMENT PARTS. USING UNAPPROVED PARTS OR MAKING UNAPPROVED MODIFICATIONS TO EQUIPMENT MAY VOID AGENCY APPROVALS AND CREATE SAFETY HAZARDS.
- CHECK THE INTERLOCK SYSTEMS PERIODICALLY TO ENSURE THEIR EFFECTIVENESS.
- DO NOT ATTEMPT TO SERVICE ELECTRICAL EQUIPMENT IF STANDING WATER IS PRESENT. USE CAUTION WHEN SERVICING ELECTRICAL EQUIPMENT IN A HIGH-HUMIDITY ENVIRONMENT.
- USE TOOLS WITH INSULATED HANDLES WHEN WORKING WITH AIRFIELD ELECTRICAL EQUIPMENT

FAILURE TO FOLLOW THESE WARNINGS WILL RESULT IN DEATH OR EQUIPMENT DAMAGE.

Refer to [Table 17](#) for the different working positions.



WARNING

Switch off the constant current regulator before manipulating the cutout.

Table 17: Cutout Working Positions

	Position A	Position B	Position C
Mode of operation	Allows the regulator to deliver current to the series circuit.	Maintenance can be done safely on the series circuit.	The series circuit insulation versus ground can be measured by applying the measurement voltage, max 9000 V DC, between the measurement socket (Item 3, Figure 2) and the ground strip (Item 8, Figure 2).
Diagram			

Table 17: Cutout Working Positions

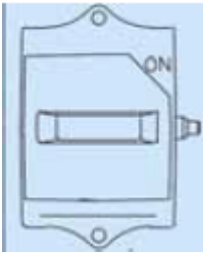
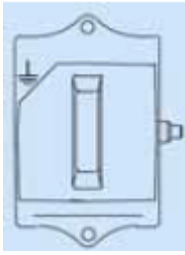
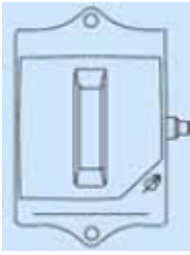
	Position A	Position B	Position C
Cover			
Handle is	horizontal	turned 90° CCW from position A	turned 270° CCW from position A
The series circuit is	connected to the CCR	Disconnected from the CCR, shorted and grounded	disconnected from the CCR, shorted and connected to the measurement socket (Item 3, Figure 2)
The CCR is	delivering current to the series circuit	shorted and grounded	shorted and grounded
The interlock switch is	activated and allows the CCR to be ON	not activated and inhibits the CCR to be ON	activated and allows the regulator to be ON (operation in short circuit)
The cover	can be locked by the key	can be locked by the key	can be locked by the key

7.0 Graphic User Interface (GUI)

The ACE3 graphic user interface (GUI) consists of a 7-inch 800 x 480 pixel full-color LCD touchscreen. In typical modes of operation, the ACE3 will display several tiles, which contain all available output data. The user can select the individual tiles to make it more prominent on the screen. Other data available on the screen include:

- Brightness step
- Remote/Local
- Primary power present / loss of power
- Communication
- IRMS status
- CCR Cycle Count
- Total Run Time
- Run Time per Step

The ACE3 GUI also contains a localized event database to allow the user to view alarms/warnings for the individual device without the need to interface with the higher level control system.

HMI Screen Map

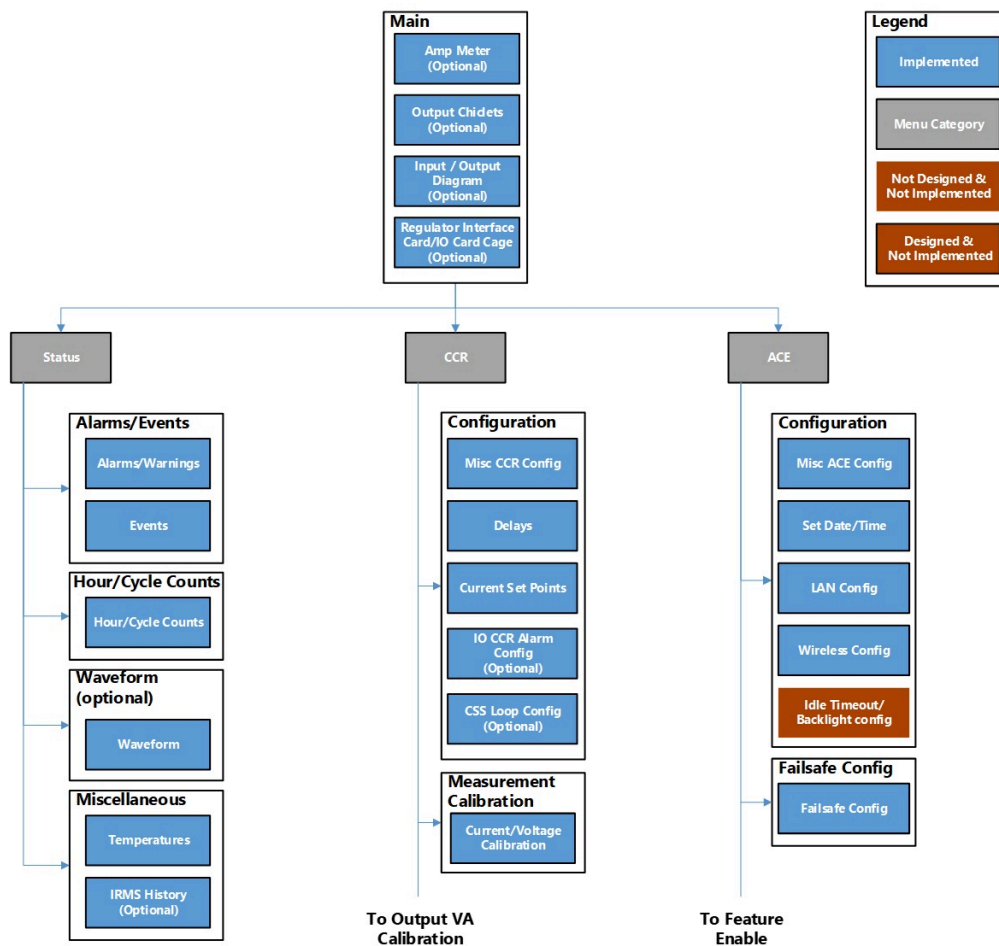

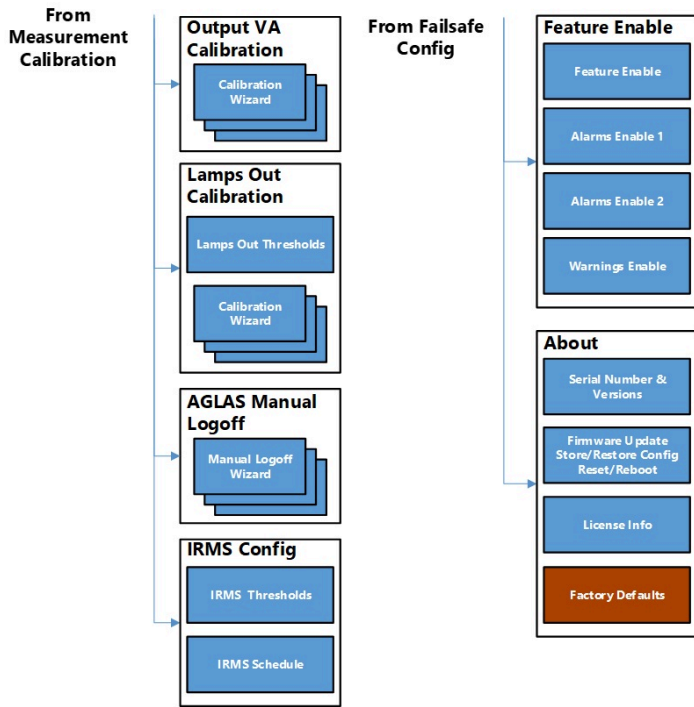

Main Display



The main screen is the first usable screen (not the splash screen) the user sees after starting the ACE3 (except when in L828 Display mode). The page is laid out with a header at the top and the body below it. The body contains a large display which shows the primary item being monitored.

There are four views associated with the main screen which can be shown or hidden based on the ACE3 configuration.

Figure 13: Output Current Gauge

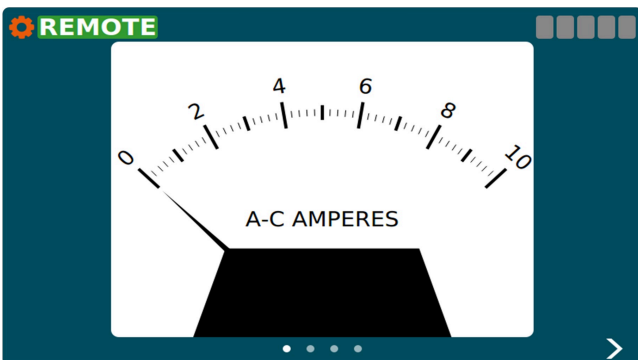

This view is shown when the ACE3 mode is "CCR" and the display mode is L828 or when the "Display Analog Current Gauge" feature is enabled.

Figure 14: Output View and Diagram View

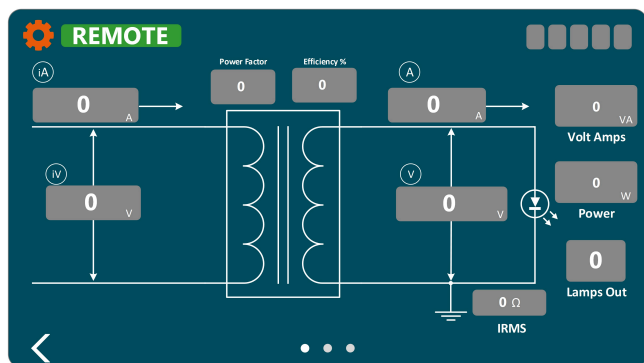

These views are shown when the ACE's mode is "CCR". The first view shows all of the output power related applications. The second view contains input power (if enabled) and output power values arranged on an electrical diagram. If the ACE's mode is "IO" neither the Output View nor the Diagram View will be displayed.

Figure 15: IO Card Cage View

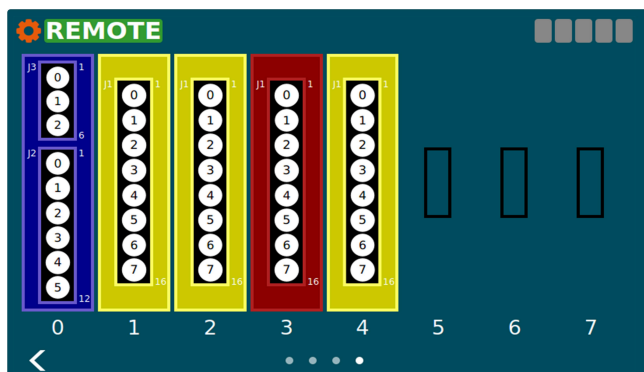

This view is shown when an IO card cage is installed. It shows what type of card is installed in which slot. Blue = Regulator Interface Card, red = output card, yellow = input card. These colors correspond to the actual color of the PCB. If the ACE's Mode is "IO" the outputs on the Regulator Interface Card and output cards can be toggled by touching the circle corresponding to the channel. The user will have to be in control before they can change the output. Touching an output while not in control causes the "Override Control" popup to be opened asking the user to take control. The channels on the output cards will turn red and input cards will turn green when the channel has gone high.

Figure 16: Regulator Interface Card View

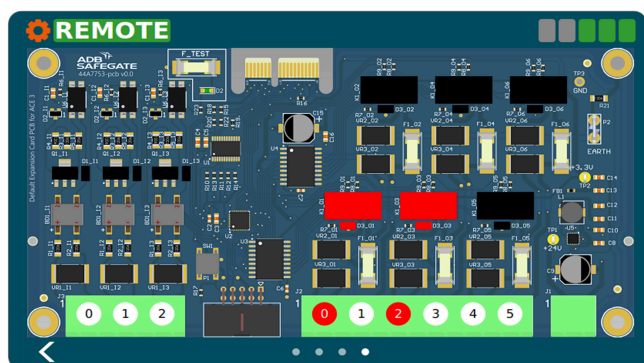

This view is shown when only the Regulator Interface Card is installed with no card cage. If the ACE's Mode is "IO" the outputs on the Regulator Interface Card can be toggled by touching the circle corresponding to the channel. The user will have to be in control before they can change the output. Touching an output while not in control causes the "Override Control" popup to be opened asking the user to take control. The board components, LED, and channel indicator on the card will turn red for outputs and green for inputs when activated.

Figure 17: Regulator Interface Card View (4x4 Card)

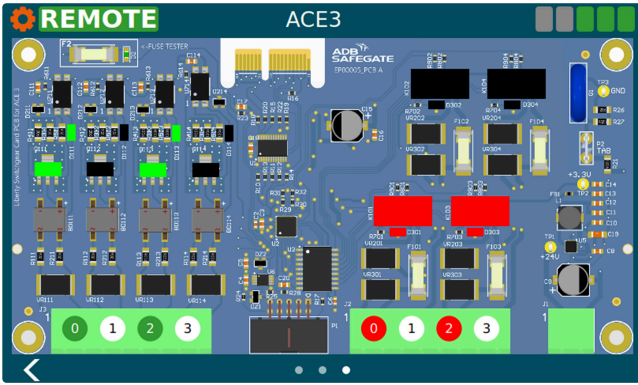



This view is shown when only the 4x4 Regulator Interface Card is installed in a URC4 integrated CCR. The user will have to be in control before they can change the output. Touching an output while not in control causes the "Override Control" popup to be opened asking the user to take control. The board components, LED, and channel indicator on the card will turn red for outputs and green for inputs when activated.

The user can switch between pages by using the navigation arrows at the bottom left and right of the screen. A page indicator located at the bottom center of the screen shows which page the user is on.

7.1 Menu Screen

Menu Overview

<p>Status</p> <ul style="list-style-type: none">Alarms/EventsHour/Cycle CountsWaveformMiscellaneous	<p>The menu will allow the user to navigate away from the main screen to various status and config screens. It is broken down into three sections "Status", "CCR", and "ACE". Under each section will be screens related to the section title.</p>
<p>CCR</p> <ul style="list-style-type: none">ConfigurationMeasurement CalibrationOutput VA CalibrationLamps Out CalibrationIRMS Configuration	<p>The menu will slide out from the left of the screen when the user presses the  icon. The menu will slide back off the screen after the user has touched somewhere outside of the menu.</p>
<p>ACE</p> <ul style="list-style-type: none">ConfigurationFailsafeFeature EnableAbout	<p>Selecting an item from the menu will replace the main screen with the chosen screen. The menu icon  will change to a left pointing arrow  indicating you can go back from the newly opened screen.</p>

Status

Alarms/Events – This will display the Alarms/Warnings/Events pages

Hours/Cycle Counts – This will display the built-in Hour/Cycle counter

Waveform – This will display a graphical representation of the input and output electrical characteristics

Miscellaneous – This page displays the internal temperature page and IRMS Viewer page

CCR

Configuration – This displays the page used for configuring CCR parameters

Measurement Calibration - This displays the page used for calibrating the output measurement of the CCR

Output VA Calibration - This displays the page used for calibrating the VA measurement of the CCR

Lamps Out Calibration - This displays the page used for calibrating Lamps Out

IRMS Configuration - This displays the page used for configuring IRMS schedule and parameters

ACE

Configuration – This displays the page used for configuring ACE parameters

Failsafe - This displays the page used for configuring failsafe parameters

Feature Enable - This displays the page used for enabling/disabling features, as well as enabling/disabling desired warnings and alarms

About – This page displays serial number and firmware information, as well as backup and restore functions

7.1.1 Alarms View

Figure 18: Alarms and Warnings Screen (Alarms View)

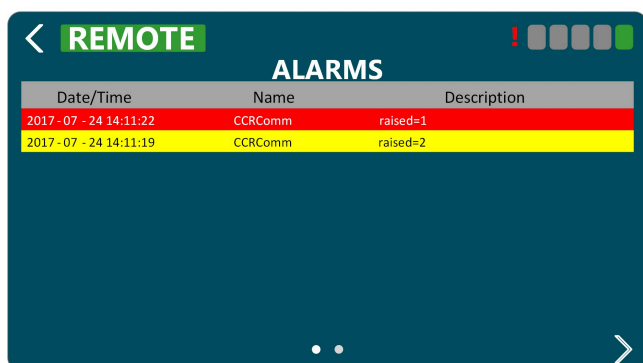

The Alarms and Warnings Screen will show all currently active alarms (red) and warnings (yellow).

Columns are follows:

- Date/Time - The date/time the alarm/warning occurred
- Name - The name of the alarm/warning
- Description - A user friendly description of the alarm/warning

The Alarm View shows the user the current alarms and warnings. Alarms/warnings that are cleared will not be shown on this screen. The list of alarms/warnings will be sorted by date/time.

7.1.2 Events View

Figure 19: Alarms and Warnings Screen (Events View)

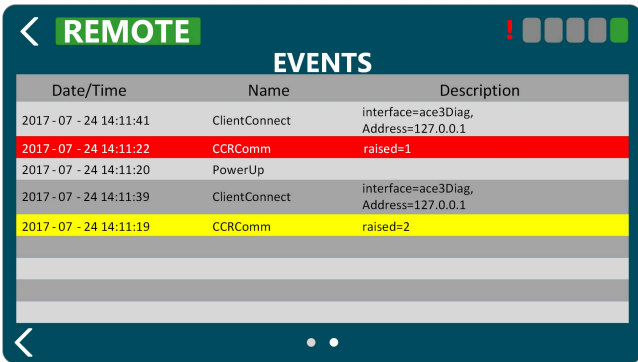

Date/Time	Name	Description
2017-07-24 14:11:41	ClientConnect	interface=ace3Diag, Address=127.0.0.1
2017-07-24 14:11:22	CCRComm	raised=1
2017-07-24 14:11:20	PowerUp	
2017-07-24 14:11:39	ClientConnect	interface=ace3Diag, Address=127.0.0.1
2017-07-24 14:11:19	CCRComm	raised=2

On the Alarms and Warning screen the event view shows a history of alarms (red), warnings (yellow), and events (grey).

Columns are follows:

- Date/Time - The date/time the alarm/warning/event occurred.
- Name - The name of the alarm/warning/event.
- Data - Information pertaining to the event.

The event view shows the time an alarm or warning started and the time it stopped. Entries which are for started alarms/warnings will be colored red or yellow. Alarms/warnings will have grayed out text and will not be red or yellow when the condition causing them has ended. General informational events will not be colored and will have regular text.

The event view is reachable by navigating right on the Alarms and Warnings Screen.

7.1.3 Status Menu - Hours/Cycle Count

Figure 20: Hour/Cycle Count Screen

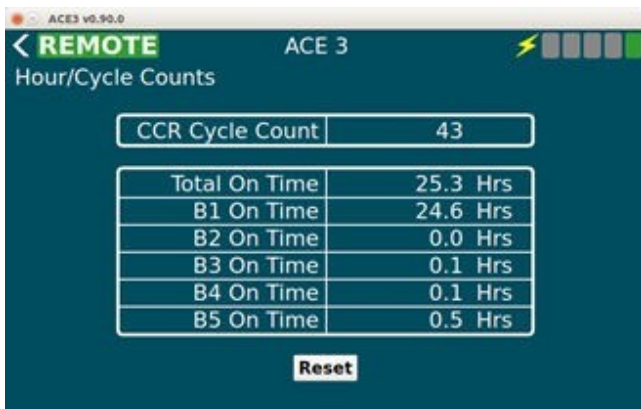

CCR Cycle Count	43
Total On Time	25.3 Hrs
B1 On Time	24.6 Hrs
B2 On Time	0.0 Hrs
B3 On Time	0.1 Hrs
B4 On Time	0.1 Hrs
B5 On Time	0.5 Hrs

Reset



Note

Only the hour counters per step and cycle count will be tracked.

The Hour/Cycle Count screen will consist of one view. This view shows how long the CCR has been on in each step and how many times the CCR was cycled (turned from off to on). At the bottom of the screen there is a reset button which will send a command to reset all statistics.

7.1.4 Status Menu – Waveform

Figure 21: Wave Form Screen

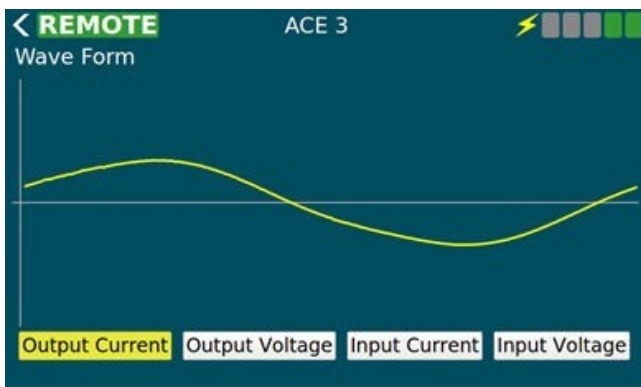

The wave form screen displays a wave form for:

- Output Current
- Output Voltage
- Input Current
- Input Voltage

The data will be in the shape of the wave and won't give exact measurements to the user. There are buttons along the bottom to turn on and off each wave form allowing the user to select which data they wish to view. The display a wave form screen will only update a few times a second to give the user an idea what the wave form looks like but **CANNOT** replace an oscilloscope.

7.1.5 Status Menu – Miscellaneous

Figure 22: Status Menu – Miscellaneous

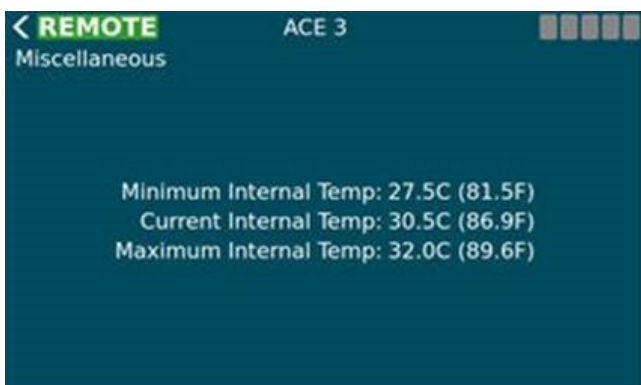

The Miscellaneous screen will contain small items which don't warrant their own page. Logical groups will be broken out into separate views on the miscellaneous page.

The Temperature view displays ambient temperature in both Celsius and Fahrenheit values. It also shows the min and max ambient temperature since the device was started. This information is not persisted through power cycles.

Figure 23: Status Menu – Miscellaneous

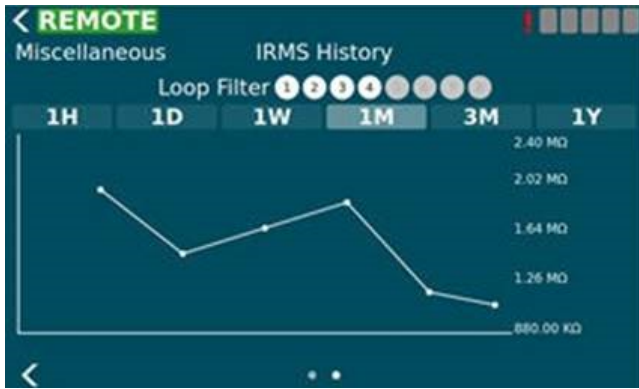

The IRMS History view allows the user to query IRMS data from the past and display it in a graph form so the user can notice trends. The user can select duration of 1 hour to 1 year. If a circuit selector is enabled a loop filter will appear at the top of the view and can be used to filter data based on loops which are being monitored.

7.1.6 CCR Menu - Configuration

The CCR Configuration screen is a set of views used to configure items related to CCR operation. This screen is disabled if the Mode configuration item on the ACE Info Configuration Screen is not set to "CCR" which indicates the ACE 3 is attached to a CCR.

7.1.6.1 Screen 1

The first page has parameters which give general information about the CCR the ACE is attached to.

- Display Mode - This modifies how the HMI presents itself to the user. L828 mode shows the Output Current gauge View only.
- Control Type - How the attached regulator is controlled
- ALCS Enabled - Indicates an ALCS system is connected to the ACE to monitor and control it. Checking this allows the ACE to enter into the failsafe mode when there are not controlling clients.
- Regulation Type - The type of regulator the ACE is connected to. This is disabled when the "Control Type" is "Integrated".
- CCR Class - CCR output current rating. This is disabled when the "Control Type" is "Integrated".
- Total Steps - The max number of steps for the CCR. This is disabled when the "Control Type" is "Integrated".
- CCR Size (W) - The size of the CCR in watts. This is disabled when the "Control Type" is "Integrated".
- CCR Extra IO - This enables communication to the IO backplane for a non-IO ACE mode. ACE mode is set in the ACE configuration menu.

Figure 24: CCR Configuration Screen 1

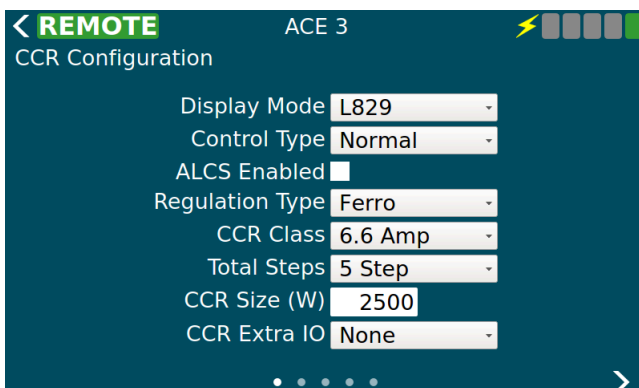

The following table describes the configurable parameters on view 1:

Control	Value	Description
Display Mode	L828	Shows the analog ammeter gauge only
	L829	Shows the full user interface
	ALCS	Currently the same as L829
Control Type	Integrated	ACE is integrated with URC4 and uses serial AIP to control the CCR
	Normal	ACE uses a Default Card to control the CCR
	Separate CC	ACE uses a Default Card and has an IO reserved to CC line
	Binary	Not Implemented yet, will be binary step control
ALCS Enabled	True	Failsafe, as configured, will be enforced Commanded step is displayed in step bars (upper right)
	False	Failsafe is disabled Reported step is displayed in step bars (upper right)
Regulation Type	Ferro	CVM2 will use Ferro Lamps Out Algorithm Lamps Out Calibration will be two phase
	Thyristor	CVM2 will use Thyristor Lamps Out Algorithm Lamps Out Calibration will be three phase
CCR Class	6.6	For 6.6 amp series circuits
	20	For 20 Amp series circuits
Total Steps	3 Step	The CCR has three steps B10, B30, B100
	5 Step	The CCR has five steps B1 - B5
CCR Size (W)	Watts	Sets open circuit voltage set point to 120% value Sets over load voltage set point to 110% value
CCR Extra IO	None	ACE doesn't monitor extra IO slots
	Standard	ACE monitors for output in slot 4, input in slot 6
	Extended	ACE monitors for output in slots 4 & 5, input in slots 6 & 7

Figure 25: CCR Configuration Screen 1 for 20A CCRs

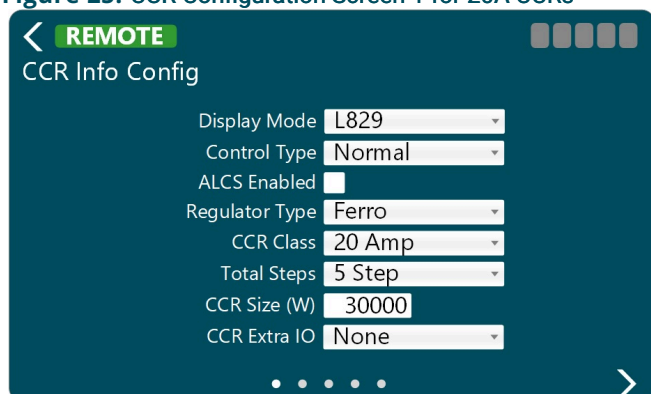

7.1.6.2 Screen 2

The Timings view allows the user to change various delays and timeouts. These timings are for operations such as changing the step or alarm conditions such as how long to stay in a 5% over current condition before generating the Over Current Alarm.

Figure 26: CCR Configuration Screen 2

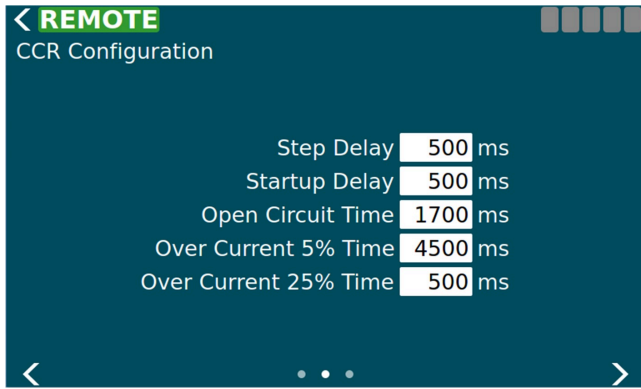

The following table describes the configurable parameters on view 2:

Step Delay	milliseconds	Amount of time to pause between steps when changing CCR step
Startup Delay	milliseconds	Amount of time to pause between off and step 1
Open Circuit Time	milliseconds	Amount of time before open circuit is declared
Over Current 5% Time	milliseconds	Amount of time 5% over before over current is declared
Over Current 25% Time	milliseconds	Amount of time 25% over before over current is declared

7.1.6.3 Screen 3

The Current Set Point view allows the user to change the expected min/max/nominal currents for each step as well as the over current set points for the 5% and 25% over current conditions.

Figure 27: Current Set Point

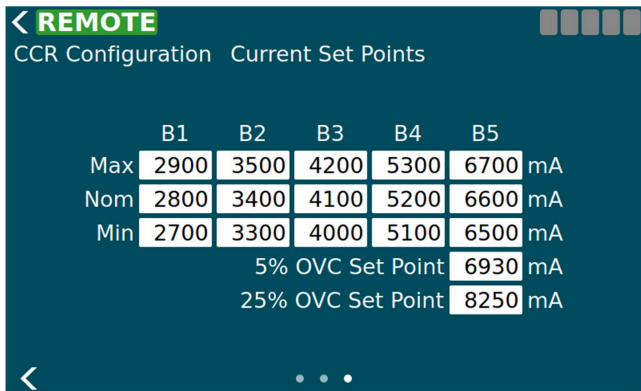
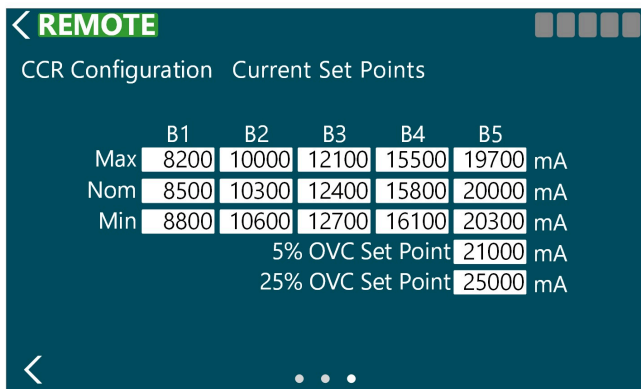

Figure 28: Current Set Point for 20A CCRs



7.1.6.4 Screen 4

The IO CCR Alarm view allows the user to configure alarms to be generated when the state of an input channel changes. The following information is displayed on the page and some things can only be changed when in advanced mode.

- Enabled - If this alarm will be generated based on input state changes.
- Slot - (only in advanced mode) The slot the card occupies in the IO card cage.
- Channel - (only in advanced mode) The channel on the card to monitor for this alarm.
- Polarity- (only in advanced mode) Determines if the alarm is generated when the input channel goes low or high. None of the changes will take effect until the "Set" button has been pressed next to each alarm (default low).

Figure 29: I/O CCR Alarm

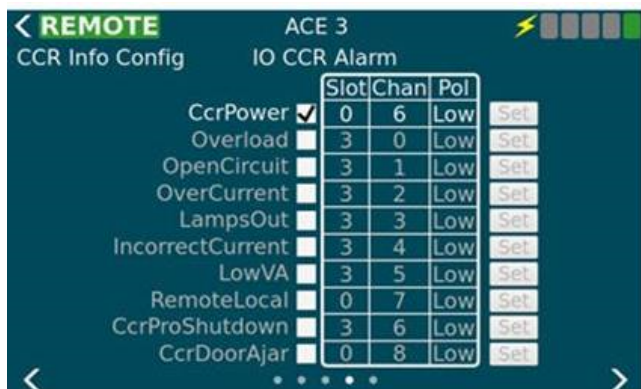

7.1.6.5 Screen 5

The CSS Loops View is used to set the various config parameters for CSS loop setup. This view will only be available if the "Circuit Selector" feature is enabled on the Feature Enable page. It allows the user to configure the following parameters for each loop.

- Enabled - If this loop is installed
- Output Slot - (only in advanced mode) The slot the card occupies in the IO card cage
- Output Channel - (only in advanced mode) The channel on the card to set for this loop
- Output Polarity - (only in advanced mode) Active high or low
- Monitored - Determines if the IO line is monitored which enables the input config parameters below
- Input Slot - (only in advanced mode) The slot the card occupies in the IO card cage
- Input Channel - (only in advanced mode) The channel on the card to set for this loop
- Input Polarity - (only in advanced mode) Active high or low (default high)

None of the changes will take effect until the "Set" button has been pressed.

Figure 30: CSS Loops

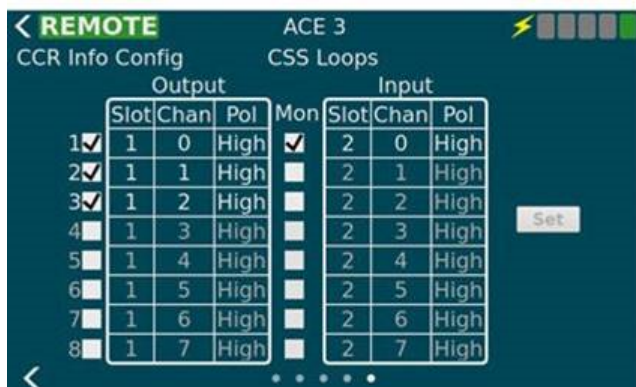



Note

Enabled output slots must be consecutive.



Note

These values are read only if the "cssAdvancedConfig" is absent (default) or set to false in the ace.ini file. If the "cssAdvancedConfig" is set to true then the **slot, channel, polarity** can be edited. A current clamp and True RMS multimeter are required to perform this calibration.

7.1.7 CCR Menu - Measurement Calibration

The Calibration screen is used to calibrate the Output Voltage, Output Current, Input Voltage, and Input Current. The calibrate button at the bottom becomes active when one or more complete units of calibration values have been filled in.

Figure 31: Calibration Screen

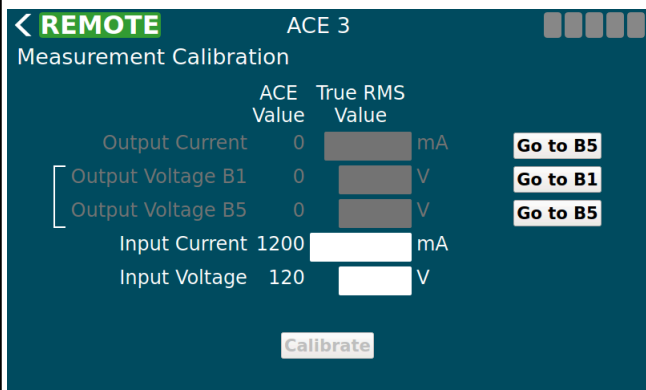

You will need a True RMS Multimeter and a current clamp.

1. Ensure the CCR switch is in Remote.
2. On the ACE3 screen, select **Go to B5**.
3. Select **Override Control**. (see Figure 32)
4. Using your True RMS multimeter and test leads, measure the input voltage of the CCR and input the value in the **Input Voltage** box.
5. Using your True RMS multimeter and current clamp, measure the input current of the CCR and input the value in the **Input Current** box.
6. Using your True RMS multimeter and current clamp, measure the output current of the CCR and input the value in the **Output Current** box.
7. After a calibration value has been entered a red "X" appears next to it allowing the user to reset that value if they want to calibrate again.
8. Select **Calibrate**.

Figure 32: Calibration Screen Override

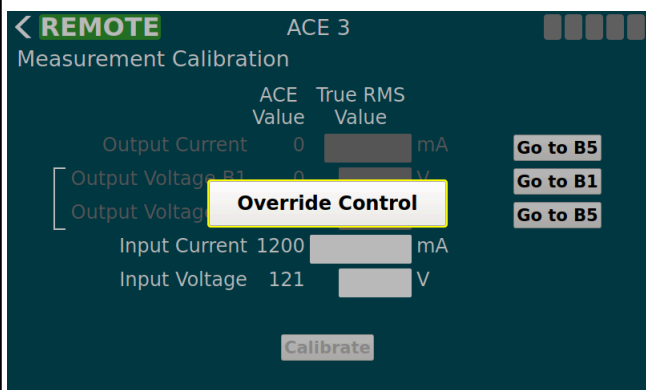

The ACE Value column displays the currently reported value until the True RMS Value column has been filled in. The ACE Value column will then stop updating until the calibrate button is 'pressed' or the value is reset with the red "X".

Figure 33: Calibration Screen with the red X shown

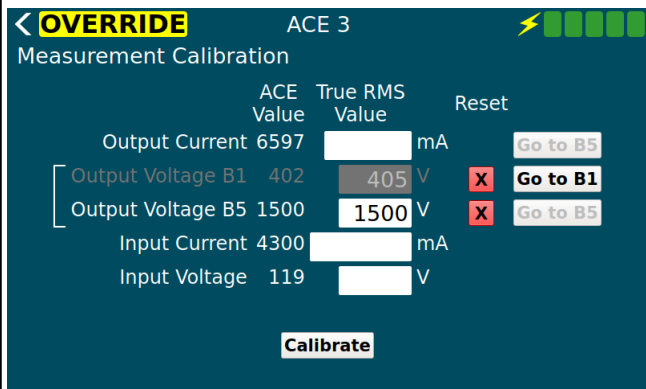

7.1.8 CCR Menu - VA Calibration

The first page of the Output VA Calibration provides a box to adjust the settling time for each step that the ACE3 will wait before taking readings. This will allow any circuit noise that occurs during step change to settle before measuring.

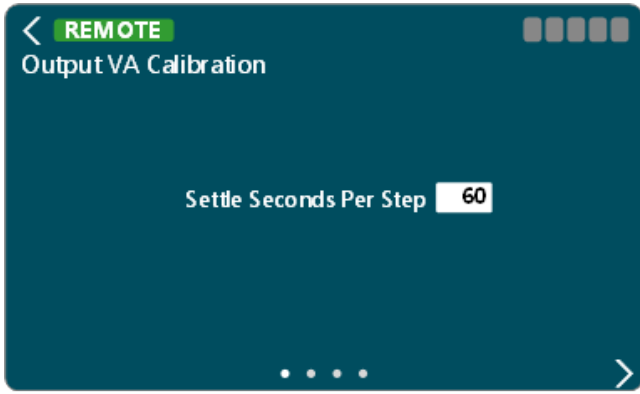

Once the value has been set, select the  button to move to the next page

The second page is where the calibration can begin. Be aware that the CCR will energize and cycle through all available steps.

Press **Start Calibration** to begin

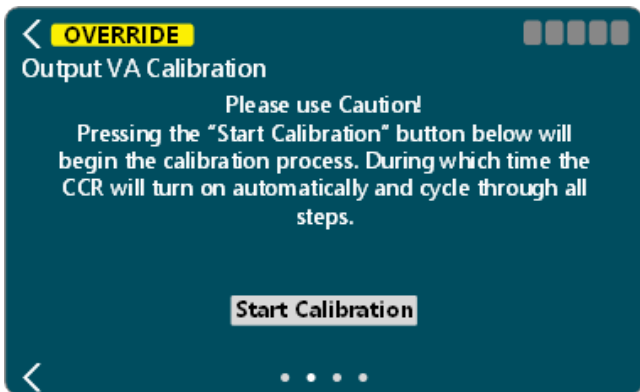

During calibration, the user will be given the ability to cancel the calibration operation, if necessary.

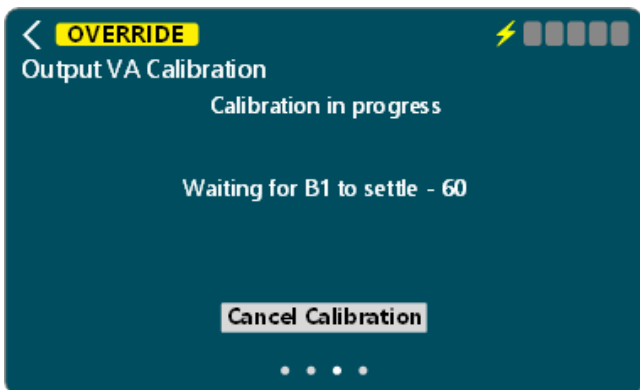

Once the calibration has completed the measurements at all steps, it will give you the ability to **Accept Results** or **Reject Results**.

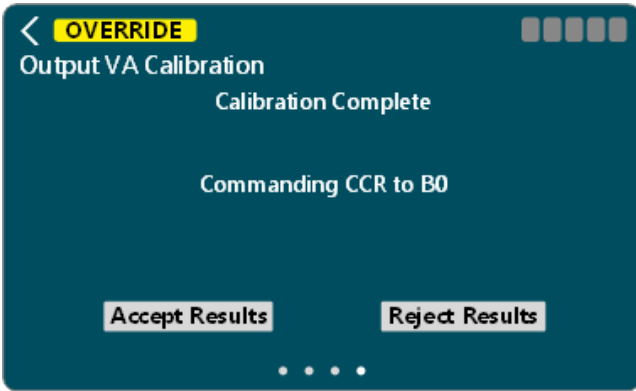

Once the results have been accepted or rejected, the calibration will complete.

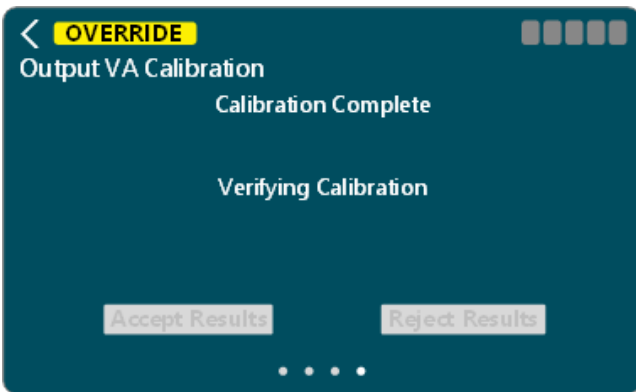

Select the  to return to the main screen

7.1.9 CCR Menu - IRMS Configuration

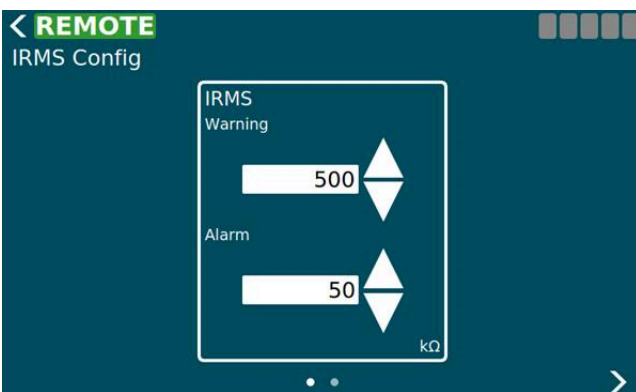

The IRMS config page allows the user to configure thresholds for IRMS alarms and warning as well as set two megging schedules.

The controls on the thresholds page allow the user to either increment or decrement the alarm/warning thresholds by one Kilo-ohm using the up/down arrows or the user can touch the value bringing up a num pad. From there they can select any value within the allowable range. Note that the alarm value must be lower than or the same as the warning.

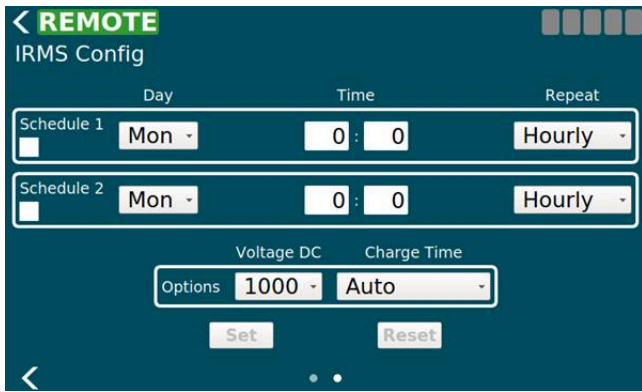

The controls on the scheduling page allow the user to setup the initial delay and the reoccurring interval as well as some additional options.

- Enable checkbox: This is used to enable and disable each IRMS schedule independently.
- Day: This is the day of this week to start the schedule. If the day is in the past then a meg will start immediately and then run again once the next reoccurring period has passed.
- Hour & Minute: The hour and minute for the initial delay. If the time is in the past then a meg will start immediately and then run again once the next reoccurring period has passed.
- Repeat: This is the repeat interval to run the meg after the initial delay has passed. Possible values are listed in the IRMS Schedule Repeat Table.
- Voltage: This is the maximum voltage the IRMS test will attempt to run at. Depending on the quality of the circuit the max may never be reached. This voltage is used for both megging schedules. Possible values are listed in the IRMS Schedule Voltage Table. Values may be set to 50, 500, or 1000 volts.
- Charge Time: The charge time is how long to charge the IRMS equipment to the desired max voltage before starting the test. Possible values are listed in the IRMS Schedule Charge Table. Note: The continuous option is not available due to a design decision.

Once the user has modified a field it will no longer be updated with changes until the user presses "Set" or "Reset". The "Set" button sends all currently displayed values while the "Reset" button removes any modifications the user has made and will refresh everything with what is currently reported.

Megging Immediately

To start a meg immediately, return to the ACE3 main screen. Press the ellipsis icon in the IRMS window.



1. Click the green arrow to start a meg check. (active if no meg is in progress) (greyed out during a meg in process). A yellow Ω icon will appear at the top of the ACE3 screen while megging is in progress.
2. Click the red box to stop the meg check. (active if a meg is in progress) (greyed out if no meg is in process)



7.1.10 CCR Menu - Lamps Out Calibration

The first view allows the user to set the lamps out thresholds before a warning and/or alarm is generated. Setting these to 0 turns the alarm and warning off. The warning value can never be greater than the alarm. The numpad or the increment/decrement arrows can both be used to change the value(s). Changes to the screen take effect immediately.

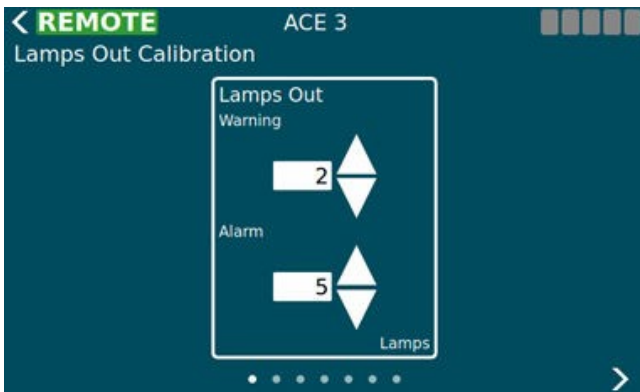

The remaining views act as a wizard. The first three views can be navigated by the user however if the user wishes to start an actual calibration then they must have control of the ACE 3 and they no longer have the ability to navigate through the wizard. They will be allowed to cancel the calibration at any time which will take them back to the first view.

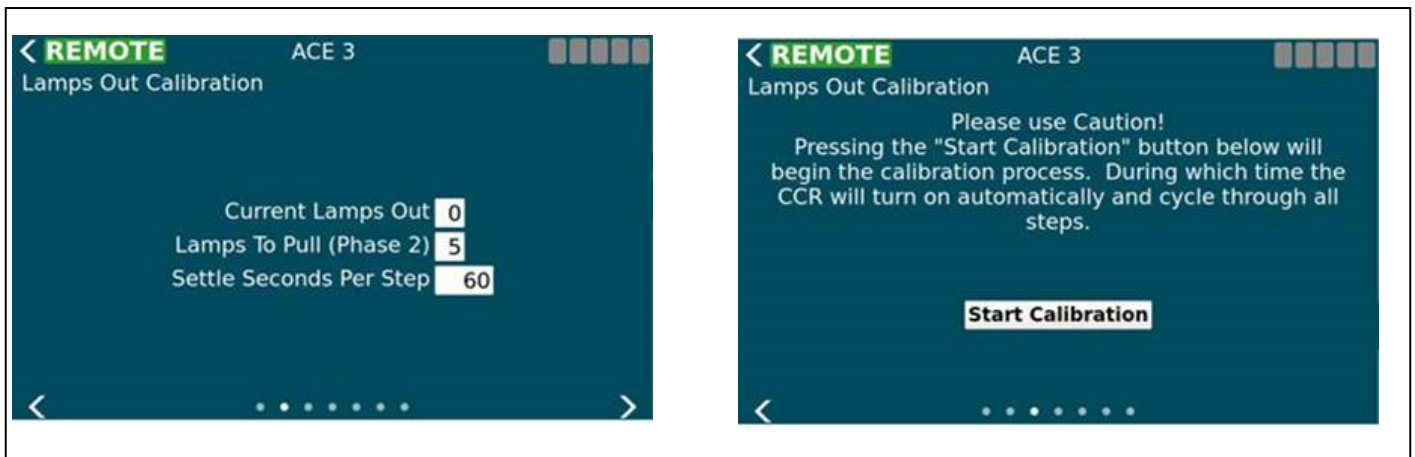

The calibration consists of two phases. The first is calibrating the existing circuit. The second is pulling a set number of lamps and calibrating again.

After calibration is complete the user can accept the results or reject them. Accepting saves the results to the ACE 3 and they will be used going forward.

Once the calibration has started, the ACE3 will command the CCR on to each brightness step, taking measurements at each step, for the duration of the configured settle time per step.

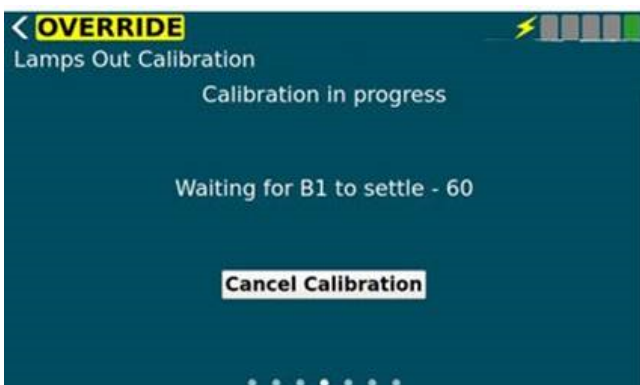

After the initial measurement phase, the user will need to pull the appropriate number of lamps*.

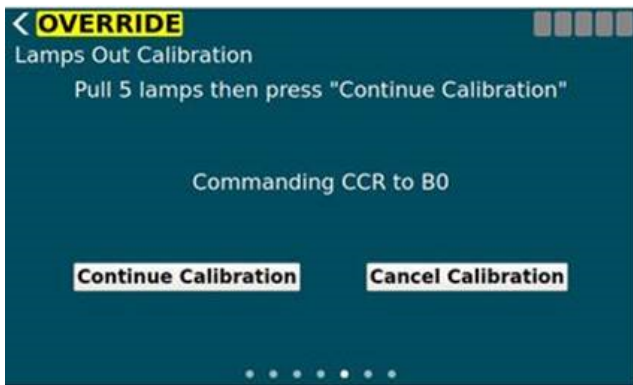

CAUTION

*Make sure the CCR is De-Energized

Press **Continue Calibration** after the lamps have been pulled.

Once the calibration continues, the ACE3 will command the CCR on to each brightness step, taking measurements at each step, for the duration of the configured settle time per step.

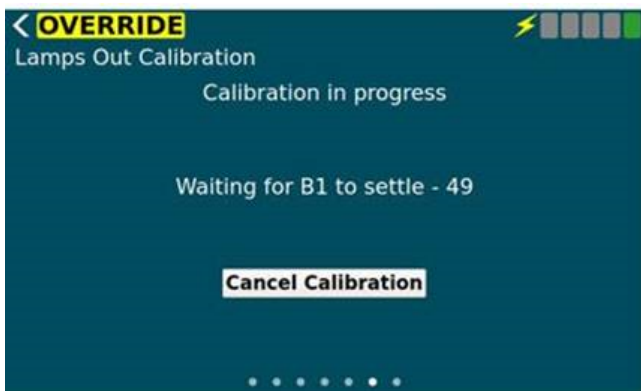

Once the calibration has completed the measurements at all steps, it will give you the ability to **Accept Results** or **Reject Results**.

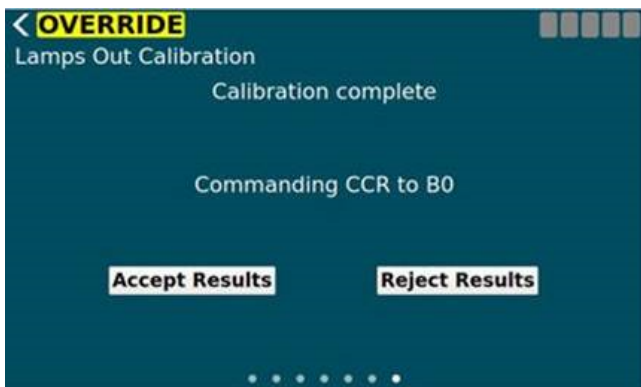

Once the results have been accepted or rejected. The calibration will complete.



Select the  to return to the main screen

7.1.11 ACE Menu - Configuration

The ACE Info Config screen has a set of views which allow the user to configure various parameters of the ACE 3. The first view is a set of miscellaneous items which setup the ACE 3.

- Name - The name of the ACE 3. This will be displayed in the header bar.
- Mode - This determines how the ACE 3 is setup. Is it connected to a CCR or is it IO only, etc...
- Port A (enabled, Baud, Address) - A checkbox to enable or disable port A (legacy ACE protocol), the baud rate, and the multi-drop address. This is only used when in ALCS mode.
- Port B (enabled, Baud, Address) - A checkbox to enable or disable port B (legacy ACE protocol), the baud rate, and the multi-drop address. This is only used when in ALCS mode.

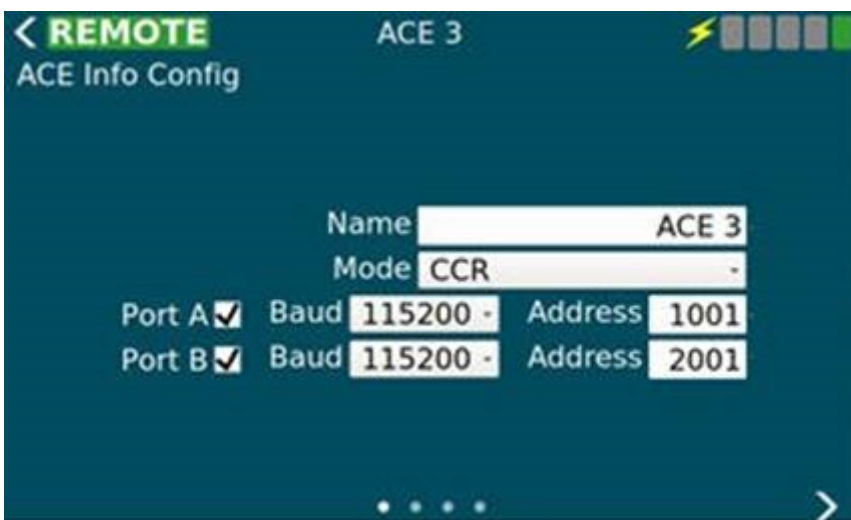

The second view allows the user to set the date and time. The date and time are set in UTC time. The user can also see the current date/time on the ACE 3. To enable NTP (Network Time Protocol) the user can check the box at the bottom of the view and specify a NTP server. The ACE 3 will then use NTP to get its time from that point on. Unchecking the box turns off the use of NTP.



The network configuration views allow the user to configure both the LAN interfaces as well as the wireless interface.

The third view allows the user to configure the two local area network (LAN) connections. Once the user has made all desired modifications they can press the "Set" button to **store** the new configuration or the "Reset" button to **erase** all local changes and use the existing configuration.

Figure 34: ACE Info Config Screen (network Config)

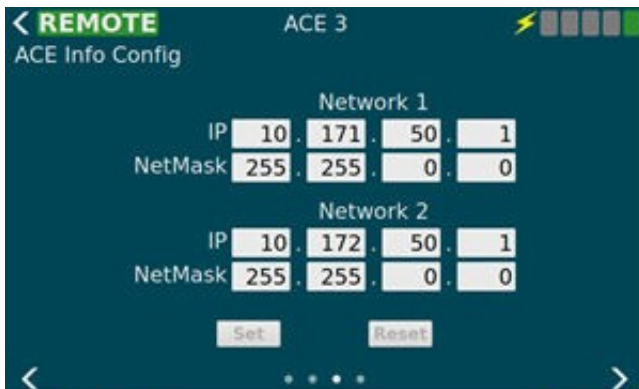

The fourth view allows the user to configure the Wireless connection located on the ACE 3. To use the WIFI interface the user must select the "Enable WIFI" checkbox at the top of the view. The network security will always be WPA2-Personal and cannot be changed from the GUI. The user can browse the broadcast SSID's and choose one by pressing the left arrow button or type in a hidden SSID directly in the "SSID" text area. The passphrase text area allows the user to type in their password. If they wish to see what they have typed they can check the "Show Passphrase" checkbox on the left hand side of the screen.

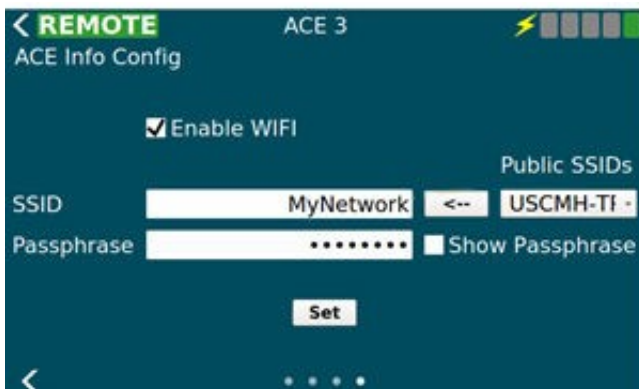

7.1.12 ACE Menu – Failsafe

The Failsafe Config screen is used to setup how the ACE 3 handles failsafe conditions. It determines when entering failsafe how the step, loops, and output cards should be set. Output Card is populated only when there are cards detected.

Figure 35: Failsafe Config Screen

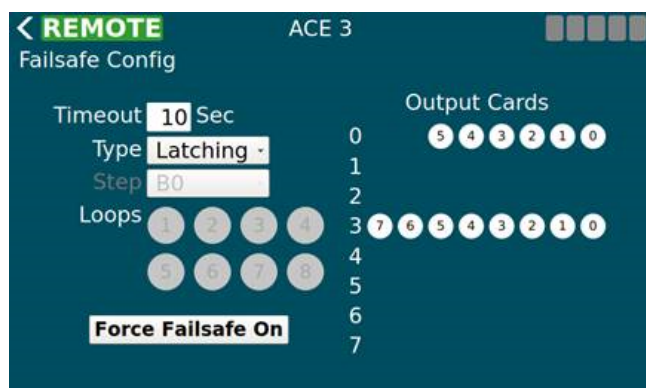

The button at the bottom can force failsafe on and off even if the ACE 3 is not in a failsafe situation.

The fail-safe mode of each ACE3 unit is defined per requirements of the airport/owner. The fail-safe modes are as follows:

- **Latching Fail-safe Mode:**

This mode is executed as follows:

- If the CCR was switched ON before the failure, it will remain ON at the same brightness level.
- If the CCR was switched OFF before the failure, it will remain OFF.

- **Simple Fail-safe Mode:**

This mode is executed as follows:

- After a failure occurs, the CCR will switch ON to a predetermined brightness level without regard to the current step.

- **Smart Fail-safe Mode:**

This mode is executed as follows:

- If the CCR was switched ON before the failure, it will remain ON at the same brightness level.
- If the CCR was switched OFF before the failure, it will switch ON to a predetermined brightness level.

7.1.13 ACE Menu – Feature Enable

The Feature Enable screen is used to enable or disable features, alarms, and warnings one at a time by checking the box next to the feature/alarm/warning name. These changes take effect immediately and are stored.

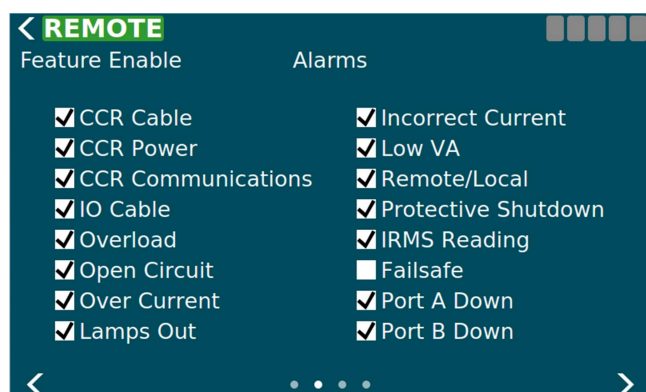

Disabling an alarm or warning prevents that alarm/warning from showing up on the alarm page and the corresponding event(s) will not be generated.

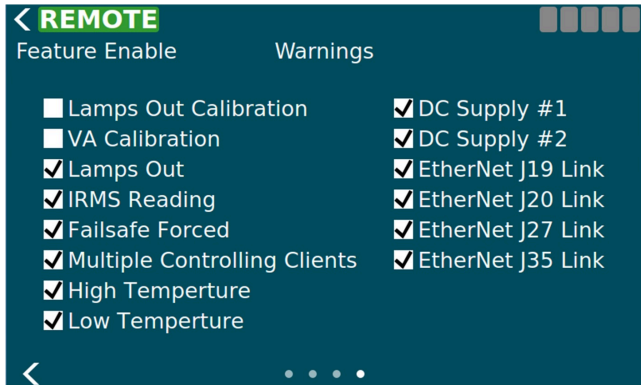
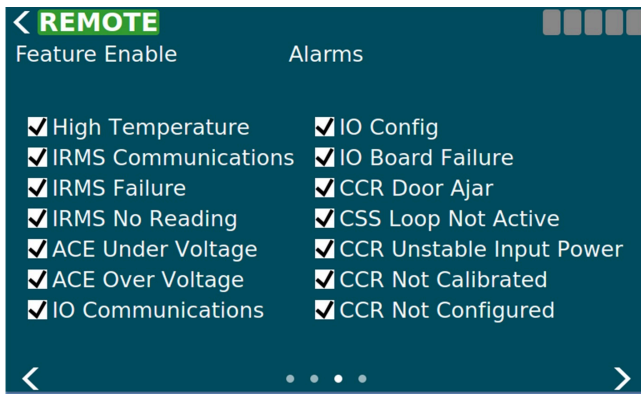

7.1.14 ACE Menu - About

The first view on the About screen displays the serial number and version info of installed modules. Using three fingers and swiping up will add a column next to the version info to display the build number for trouble shooting purposes.

Figure 36: About Screen

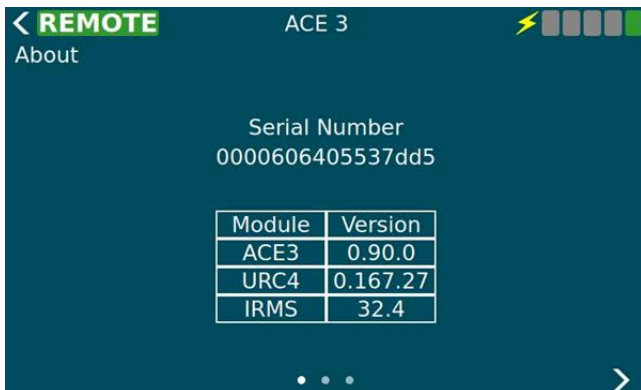

The second view is a collection of buttons which do system maintenance activities. On this view the user can upgrade the software from a USB device, restart the ACE 3 software only, restart the entries ACE 3 device, backup the ACE 3 (config, calibration data, logs, database) to a USB device, restore the ACE 3 (config, calibration data, logs, database) from a USB device.

Figure 37: About Screen Menu

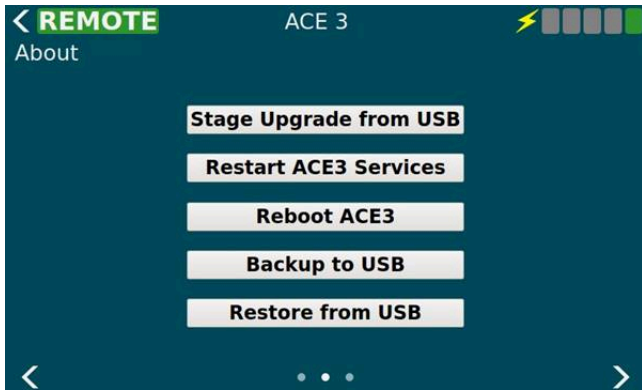

The third view shows any licensing info such as the LGPL license and any other related info. This information comes from a text file so it can be customized by the legal department. There is no limit on the length of the text since this view's contents are scrollable.

Figure 38: About Screen Disclaimer

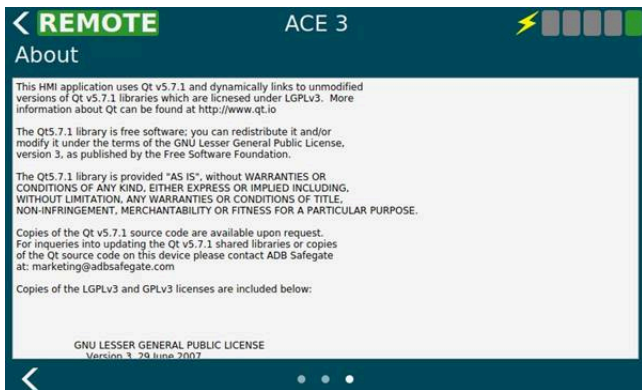

8.0 Maintenance and Repair

This section provides maintenance and repair instructions for the Ferroresonant L-828 and L-829 Air-cooled CCRs.



CAUTION

Only personnel authorized to work on high-voltage equipment should perform maintenance on the regulator.

Operate regulator under local control (using rotary switch) when performing maintenance tasks on the regulator. This will prevent the regulator from accidentally being turned on and causing serious injury or death. De-energize regulator by turning rotary switch to OFF, and remove input power to regulator by turning off disconnect switch or main circuit breaker before opening access door to service regulator.

If the regulator experiences an over-voltage or an over-current fault, it will enter protective shutdown mode. In this mode, the regulator turns off until either power to the regulator is cycled, or the regulator is turned off with either the rotary switch or the remote controls.

8.1 Maintenance Safety



DANGER

ELECTRIC SHOCK HAZARD

THIS EQUIPMENT MAY CONTAIN ELECTROSTATIC DEVICES

- DO NOT OPERATE A SYSTEM THAT CONTAINS MALFUNCTIONING COMPONENTS. IF A COMPONENT MALFUNCTIONS, TURN THE SYSTEM OFF IMMEDIATELY.
- DISCONNECT AND LOCK OUT ELECTRICAL POWER.
- ALLOW ONLY QUALIFIED PERSONNEL TO MAKE REPAIRS OR REPLACE MALFUNCTIONING COMPONENTS ACCORDING TO INSTRUCTIONS PROVIDED IN MANUAL.

FAILURE TO FOLLOW THESE INSTRUCTIONS CAN RESULT IN DEATH OR EQUIPMENT DAMAGE

8.2 Maintenance Schedule

To keep the L-828/L-829 CCRs operating efficiently, follow a preventive maintenance schedule. Refer to [Table 18](#).

Table 18: L-828/L-829 CCR (4-30 kW) Maintenance

Interval	Maintenance Task	Action
Daily	Check all control equipment for proper operation.	Check local and remote control (if used) on each brightness step.
Monthly	Check input voltage.	If input voltage is not within -5% to +10% of the nominal value specified on the nameplate of the regulator, notify power company to correct voltage.
	Check and record output current on each brightness step.	Use a true rms-reading instrument. Adjust current levels if out of tolerance. Refer to Adjustment Procedures . Refer to the tables in Local Control Table 8 for the current range for the 3-Step and 5-Step CCRs.
Annually	Check relays, wiring and insulation.	Clean dirty or slightly pitted contactor contacts. Use a fine file for surface cleaning. Replace contacts that are excessively burned or pitted. Operate the local control switch to check for proper operation of relays and contactors. Make sure input and output connections are tight and that no damaged wires or damaged insulation exists.
	Inspect housing for rust spots.	Clean and touch-up rust spots with paint.
	Inspect lightning arrestor connections.	Tighten any loose connections. Replace charred or burnt wiring or broken arrestors.

Table 18: L-828/L-829 CCR (4-30 kW) Maintenance

Interval	Maintenance Task	Action
	Perform a short-circuit test.	Refer to <i>Short-Circuit Test</i> in this section.
	Perform an open-circuit test.	Refer to <i>Open-Circuit Test</i> in this section.
Unscheduled	Check load on regulator.	At installation and subsequent load changes make sure that the output RMS voltage times the output true RMS current does not exceed the rated load on the nameplate of the regulator.

8.2.1 Short-Circuit Test



CAUTION

Read the instructions in their entirety before starting installation.

Only personnel authorized to work on high-voltage equipment should perform maintenance on the regulator.

To perform the short-circuit test, perform the following procedure:

1. Remove input power to the regulator (turn off disconnect switch or main circuit breaker) and turn the rotary switch to OFF.
2. Remove leads from output terminals and bushings. Use AWG 8 or larger wire to short output bushings.
3. Energize the regulator and turn the rotary selector switch to the lowest brightness step (1) and then to the remaining brightness steps. Check the output current on the ammeter at each step.



Note

The output current should be within the tolerance given in Table 9. The panel meter is intended to indicate function. Any calibrations should be performed with a calibrated True-RMS current meter.

4. If the output current is not within the limits specified in Table 9, check the input voltage to the regulator. The supply voltage should be within -5% to +10% of the nominal input voltage given on the regulator nameplate. Refer to [“CCR Adjustment Procedures” on page 40](#).
5. Turn off disconnect switch or main circuit breaker to remove input power to regulator.
6. Disconnect the shorting jumper and reconnect output cables.
7. Close input-power disconnect switch or main circuit breaker..

8.2.2 Open-Circuit Test



CAUTION

Read the instructions in their entirety before starting and procedures.

Only personnel authorized to work on high-voltage equipment should perform maintenance on the regulator.

Since high open-circuit voltages may result by opening the output of the regulator, only personnel authorized to work on high-voltage equipment should be allowed to perform the open-circuit test.

To perform the open-circuit test, perform the following procedure:

1. Remove input power to regulator (turn off disconnect switch or main circuit breaker) and turn the rotary switch to OFF.
2. Disconnect cables from the output terminals and bushings.
3. Turn on input power to the regulator.

4. Turn the rotary switch to the lowest brightness position (1). The open-circuit protective device should automatically de-energize the regulator in less than 2 seconds.
5. Turn the rotary switch to OFF. The open-circuit protective device should reset.
6. Turn the rotary switch to position 1. The regulator should turn on and then de-energize in less than 2 seconds.
7. If regulator operation is satisfactory, turn rotary switch to OFF, and turn off disconnect switch or main circuit breaker before reconnecting the load.
8. After the load has been reconnected, turn on input power to the regulator.

8.3 Component Replacement Procedures

8.3.1 Removing and Replacing URC4 Regulator Control PCB



CAUTION

It is very important to match the configuration for regulator type and regulator class when replacing the URC4. Take a picture and write down the switch positions of the URC4 prior to starting this procedure.

1. Turn CCR local switch to the OFF position.
2. Remove and "lock out/tag out" primary power to the CCR at the breaker panel.
3. Lock out/tag out the SCO in the maintenance position.
4. Loosen the door latch screws and open the CCR door.
5. Unplug all connectors from the PCB.
6. Disconnect the ribbon cable from J10 by pressing out on the tabs at both sides of the ribbon connection and pull the cable away from the board.
7. Remove the 4 screws at the 4 corners of the PCB. Retain the standoffs.

Figure 39: PCB URC4 Regulator Control (44A7693)

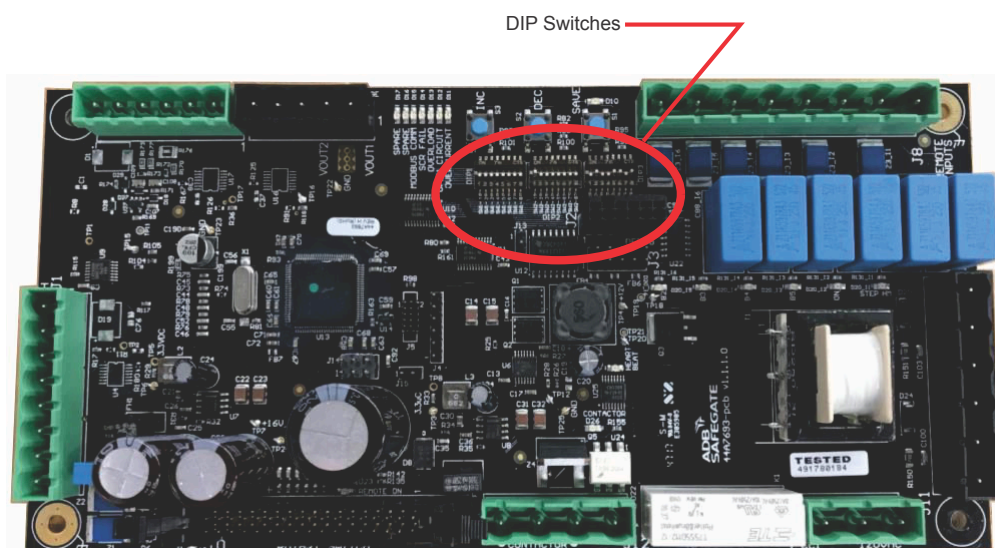

8. Ensure that the DIP switches of the new board match exactly to those of the board being replaced.
9. Mount the new PCB by replacing the 4 screws and the standoffs at the corners of the PCB.
10. Plug the ribbon cable back into J10 by pressing it in. It is keyed and will only go in one way. Also verify the tabs on the side have locked into place.

11. Plug in all of the connectors disconnected in step 5 to the PCB.
12. Close the CCR door and tighten the door latch screws.
13. Restore the SCO to the ON position.
14. Restore primary power to the CCR at the breaker panel.
15. Turn the CCR local switch to the REM position.

8.3.1.1 DIP Switches Bank Positions

Table 19: DIP Switch Bank 1



Bank	Position	Purpose
1	1	Factory Reset OFF = Normal Detection ON = Load Default Configuration
	2	Style (3/5 step) OFF = 5 step ON = 3 step
	3	 CAUTION Disconnect any load and short the output of the regulator before testing with this DIP switch enabled.
		ON = Calibration Mode (105% OC) (Default to OFF)
	4	 CAUTION Disconnect any load and short the output of the regulator before testing with this DIP switch enabled.
		ON = Calibration Mode (125% OC) (Default to OFF)
	5	Start Mode OFF = Hard start ON = Soft start Hard start injects around 2.8A of current into the field circuit upon regulator activation before moving to the set step. This is done to synchronize flashing loads such as runway guard lights.
		 Note When URC4 is setup for 20 amp mode the CCR will always operate in "soft start". So the position of the dip switch which selects hard/soft start (default hard) is ignored.
6	URC4 Input Power Door Switch OFF = No URC4 input power door switch ON = URC4 input power door switch installed	
7	Reserved for Manufacturer (Default to OFF)	
8	Reserved for Manufacturer (Default to OFF)	

Table 20: DIP Switch Bank 2



Bank	Position	Purpose
2	123	 CAUTION Disconnect any load and short the output of the regulator before testing with this DIP switch enabled.
		Regulator Type 1 = ON, 0 = OFF 000 = Ferro 100 = Thyristor 010 = SynchroThyristor 110 = Synchro-Tap 001 = Ferro with TVPT 101 = Reserved 011 = Reserved 111 = Reserved
	4	Reserved for Manufacturer (Default to OFF)
	5	Reserved for Manufacturer (Default to OFF)
	6	 CAUTION It is very important when replacing the URC4 to match the Regulator type.
		Class (6.6/20 amp) OFF = 6.6 amp ON = 20 amp
	7	Output Voltage Sensing OFF = Core Winding ON = External Transformer
	8	Reserved for Manufacturer (Default to OFF)

Table 21: DIP Switch Bank 3

Bank	Position	Purpose
3	1 2 3 4	Input Volts 1 = ON, 0 = OFF 120 VAC = 0000 208 VAC = 1000 220 VAC = 0100
		230 VAC = 1100
		240 VAC = 0010
		347 VAC = 1010
		380 VAC = 0110
		400 VAC = 1110
		480 VAC = 0001
		600 VAC = 1001

Table 21: DIP Switch Bank 3

Bank	Position	Purpose
		Output Power 1 = ON, 0 = OFF 200 Watts = 0000 1 KW = 1000 2 KW = 0100
	5 6 7 8	3 KW = 1100 4 KW = 0010 5 KW = 1010
		8 KW = 0110 10 KW = 1110 15 KW = 0001
		20 KW = 1001 25 KW = 0101 30 KW = 1101

8.3.2 Removing and Replacing Input Lightning Arrestors

From the front of the Component Mounting Plate:

1. Turn CCR local switch to the OFF position.
2. Remove and lock out/tag out primary power to the CCR at the breaker panel.
3. Lock out/tag out the SCO in the maintenance position, if applicable.
4. Open the CCR front door by loosening the 3 door screws.
5. Loosen the wire retaining screws for 100, 402, 101, 403, 802 and 803 and disconnect. See Internal Wiring Schematic, 43A4028.dwg in "[Wiring Schematics](#)".
6. Remove the top two of (4) #10 x 32 pan-head screws and loosen the bottom two screws until the arrestors are free.
7. Replace the Input Lightning Arrestor assembly. Replace the two top screws on the assembly plate and tighten all four until the arrestors are secure.
8. Connect the wires for 100, 402, 101, 403, 802 and 803 and tighten retaining screws.
9. Close the CCR front door by tightening the 3 door screws.
10. Restore the SCO to the "In Service" position.
11. Restore primary power to the CCR at the breaker panel.
12. Turn the CCR local switch to the REM position.

8.3.3 Removing and Replacing Output Lightning Arrestors

Remove and replace the Output Lightning Arrestor components:

1. Turn CCR local switch to the OFF position.
2. Remove and lock out/tag out primary power to the CCR at the breaker panel.
3. Lock out/tag out the SCO in the maintenance position, if applicable.

4. Remove the side panel of the CCR, by removing the 8 mounting screws. Be careful as you will also need to disconnect the ground wire attached from the frame to the panel.

Figure 40: Output Lightning Arrestors

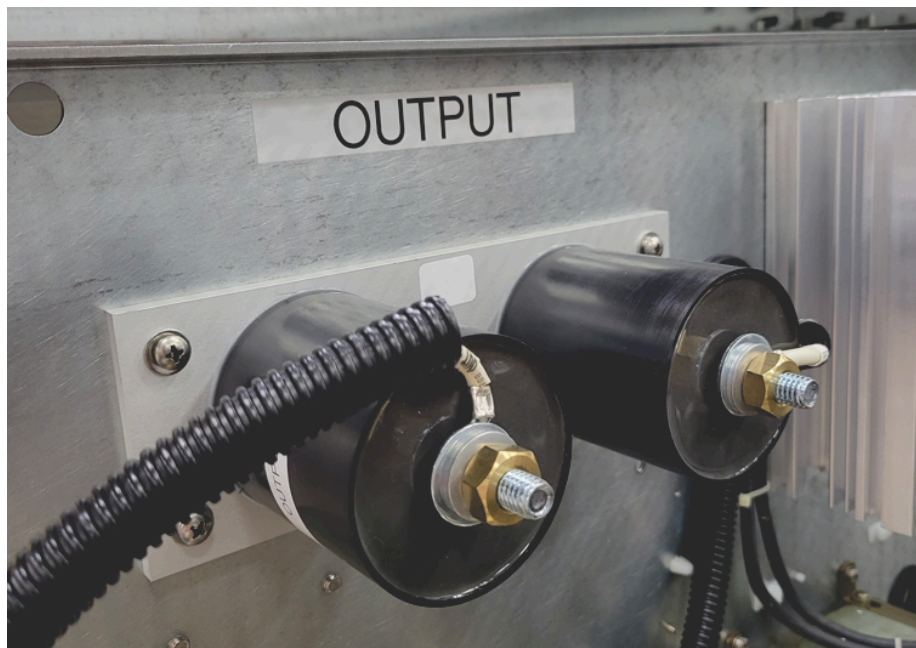

5. Refer to the [Wiring Schematics](#) section. Remove the 11/16-inch brass nut and disconnect the output wires. Keep wires organized for easier re-assembly.
6. Remove the (4) #10 x 32 pan-head screws and retain until later.
7. Replace the Input Lightning Arrestor assembly. Replace and tighten the screws on the assembly plate.
8. Re-connect output wires to VR1 and VR2 according to wiring schematic. Ensure a proper connection assembly by installing the ring terminals first against the lightning arrestor, then the flat washer, then the Belleville washer (cupped towards the lightning arrestor), and the 7/16-inch brass nut. Torque to 26 lb/ft (35.3 Nm).
9. Connect the ground wire from the frame to the side panel.
10. Put the side panel back on the CCR with the 8 screws.
11. Restore the SCO to the "In Service" position.
12. Restore primary power to the CCR at the breaker panel.
13. Turn the CCR local switch to the REM position.

8.4 Wiring Schematics

Figure 41: Internal Wiring Schematic (Main, sheet 1/page 1)

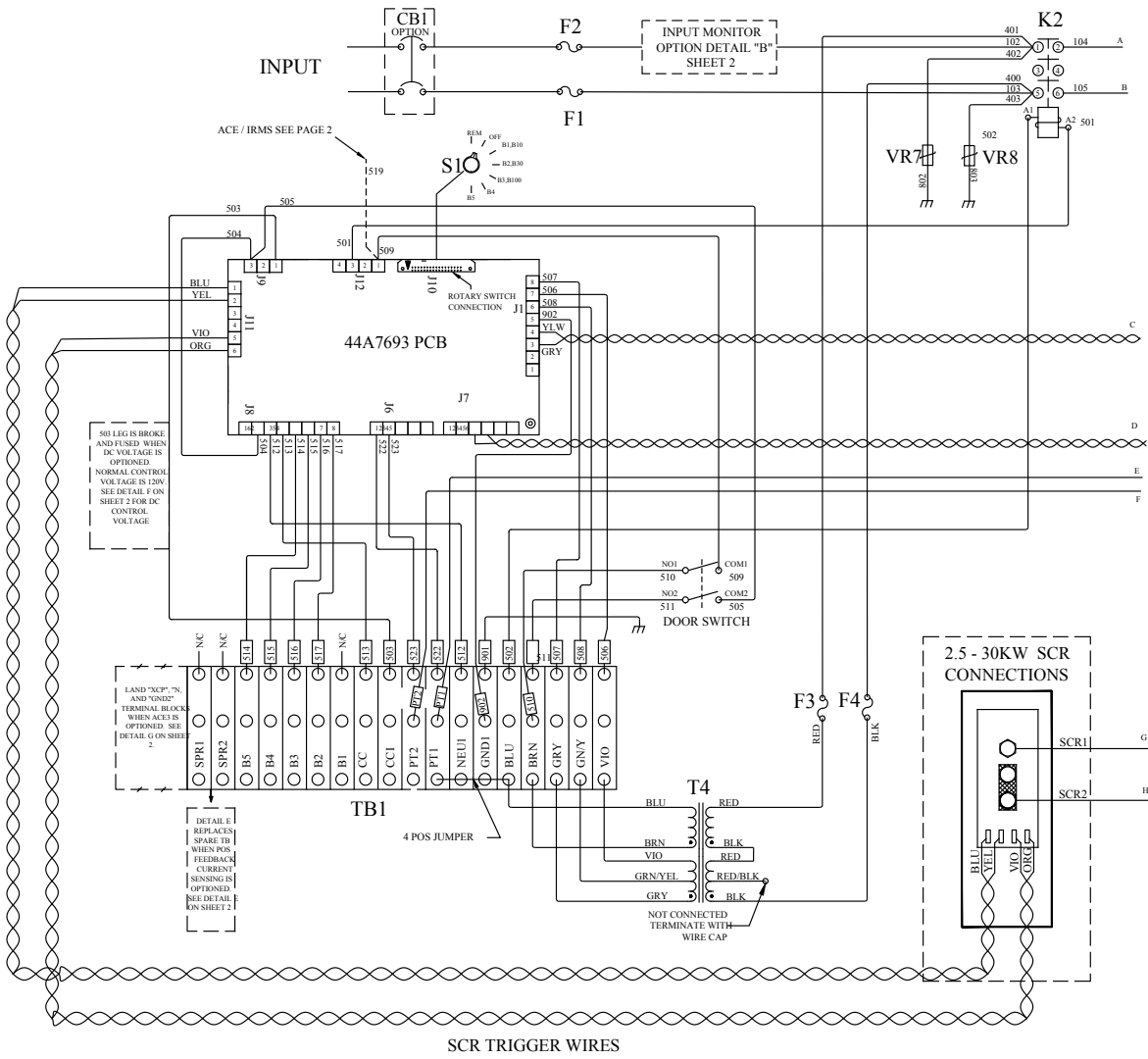

Figure 42: Internal Wiring Schematic (Main, sheet 1/page 2)

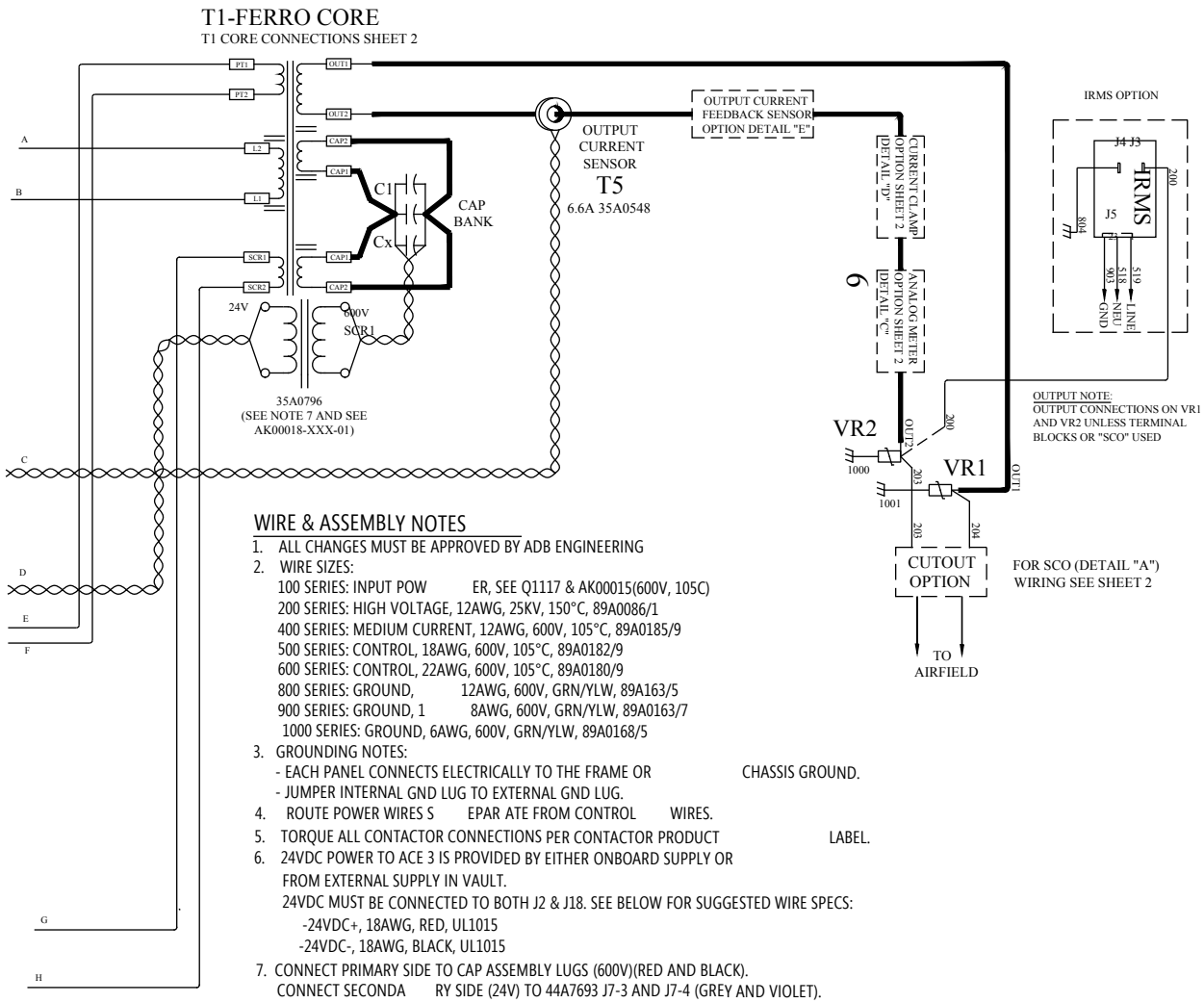
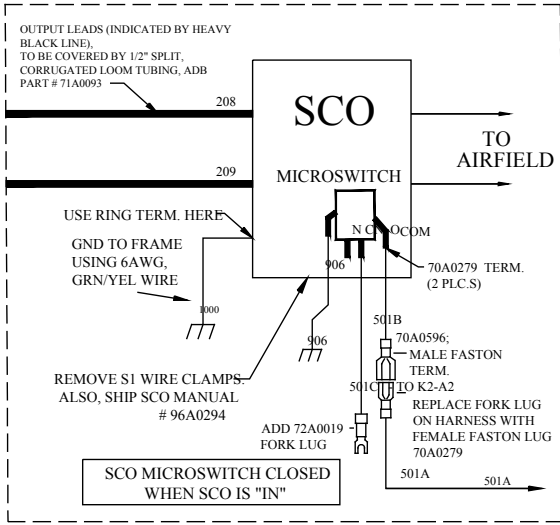
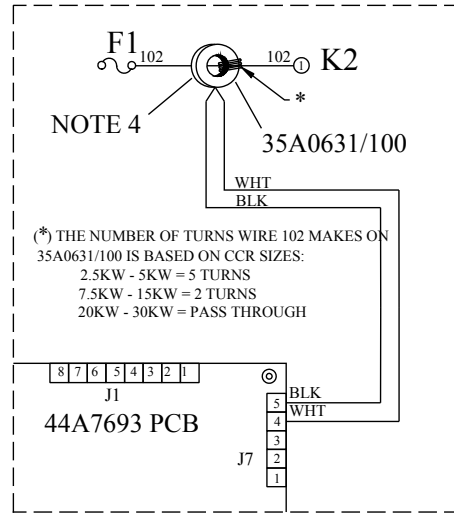

Figure 43: Internal Wiring Schematic (Details A-D)

DETAIL "A": SERIES CUT OUT (SCO) OPTION SEE
 "CUTOUT OPTION" ON SHEET 1 FOR LOCATION



DETAIL "B"
 INPUT MONITOR OPTION



DETAIL "C"
 ANALOG METER OPTION

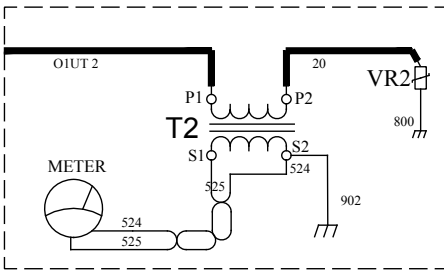

DETAIL "D"
 CURRENT CLAMP OPTION

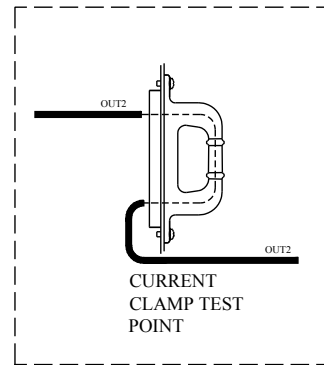

Figure 44: Internal Wiring Schematic (Details E-F)

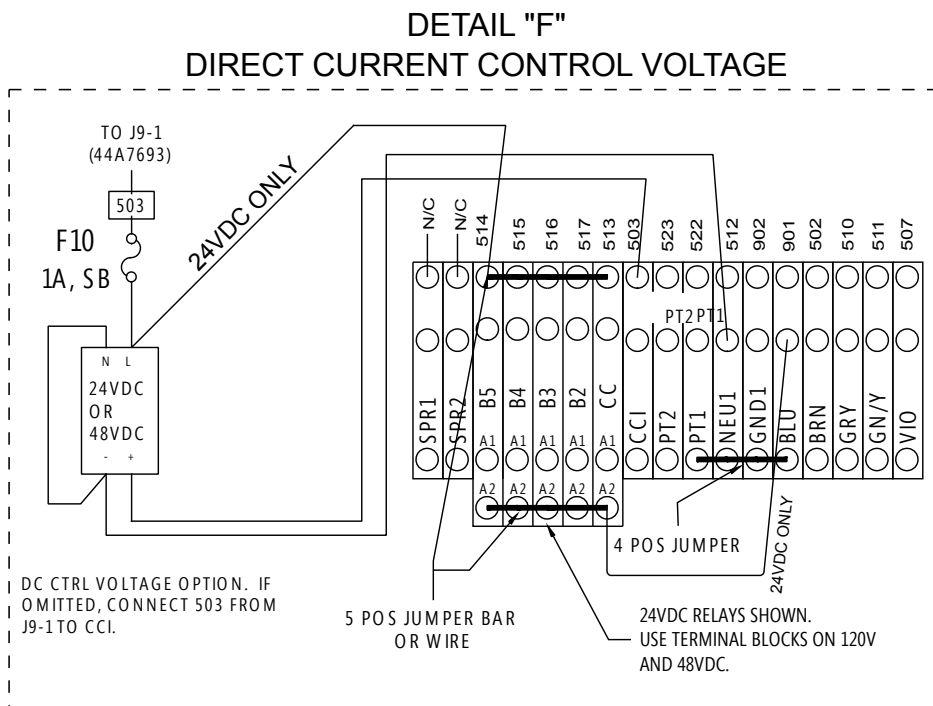
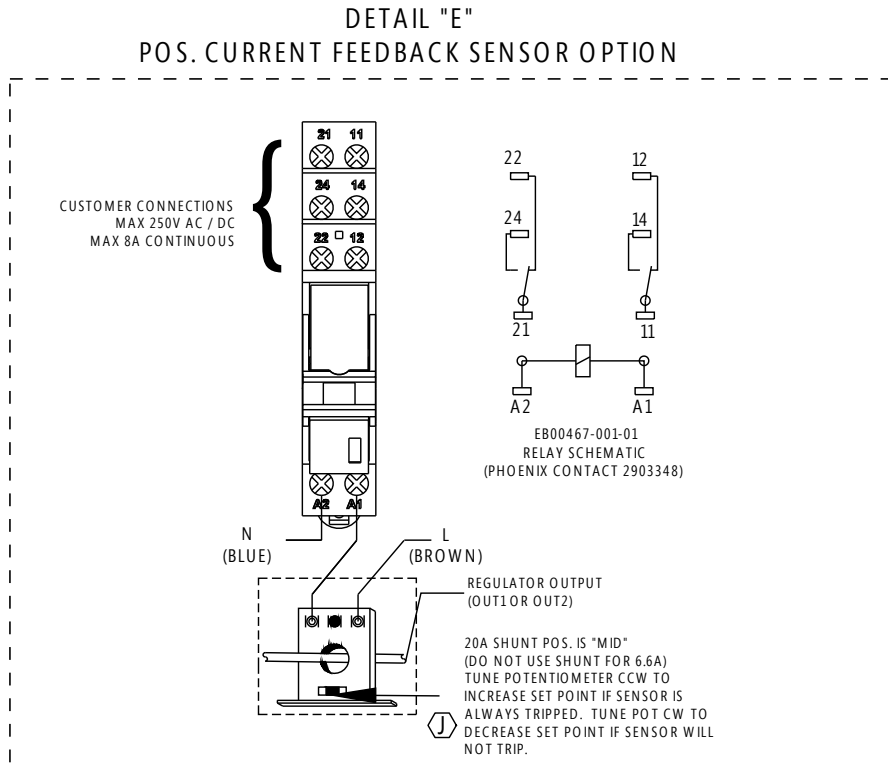

Figure 45: Internal Wiring Schematic (Detail G - ACE3)

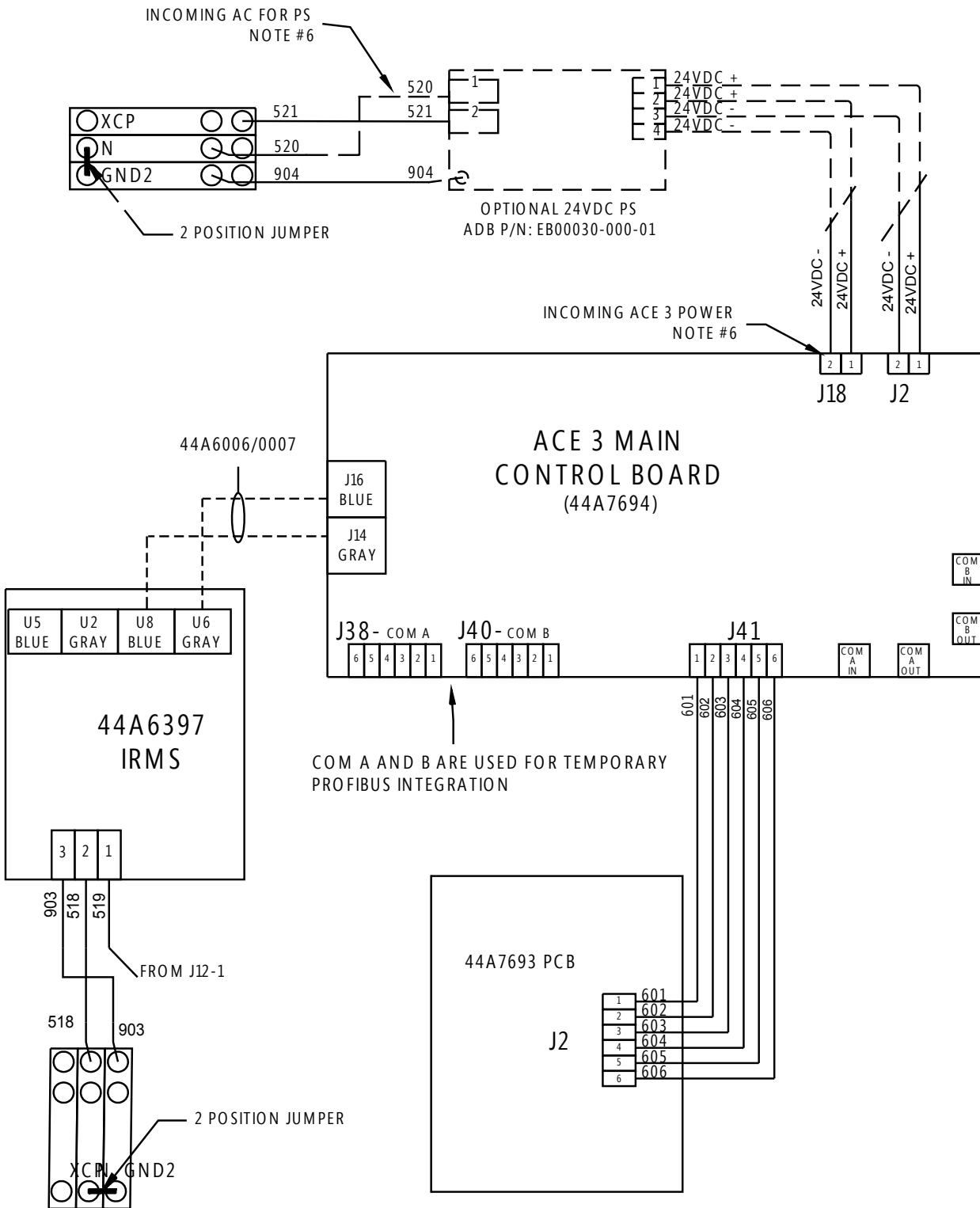
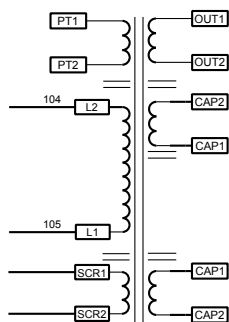

Figure 46: Internal Wiring Schematic (T1)

T1 WIRING CONNECTIONS

T1: 2.5-30KW; 600V, 60HZ
(SINGLE TAP)



T1: 2.5-30KW; 240/480V,
60HZ (240V SHOWN)

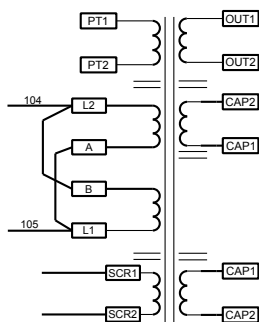

T1: 2.5-30KW; 208/220/240V,
50/60HZ (MULTI-TAP)

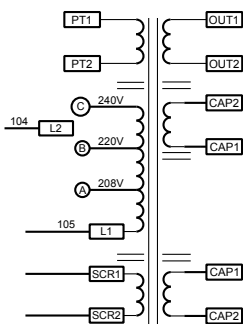

T1: 2.5-30KW; 347/380V,
60HZ (MULTI-TAP)

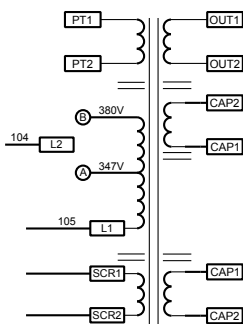

T1: 2.5-30KW; 240/480V,
60HZ (480V SHOWN)

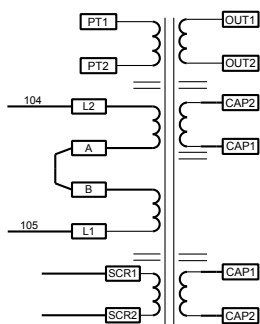

T1: 2.5-30KW; 380/400V,
50HZ (MULTI-TAP)

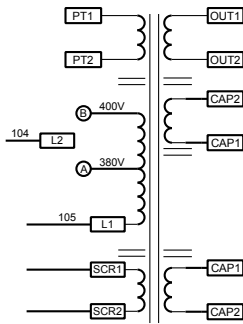
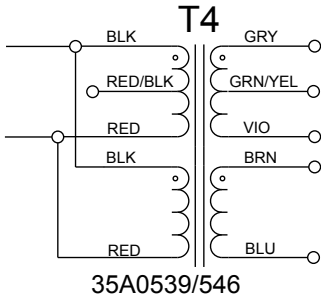

Figure 47: Internal Wiring Schematic (T4)

T4 WIRING CONNECTIONS

"T4" CONTROL TX:

208/220/240V, 50/60HZ INPUT



"T4" CONTROL TX:

347/380V, 60HZ INPUT

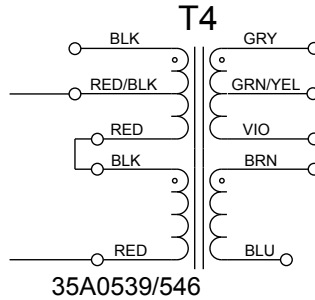

"T4" CONTROL TX:

600V, 60HZ INPUT

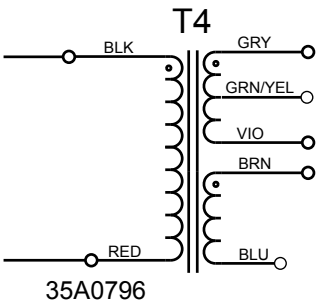

"T4" CONTROL TX:

208/220/240V, 60HZ INPUT

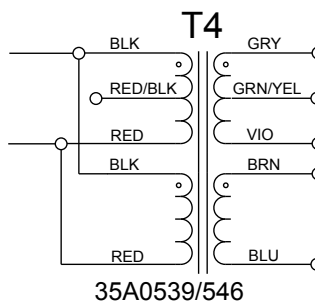

"T4" CONTROL TX:

380/400V, 50HZ INPUT

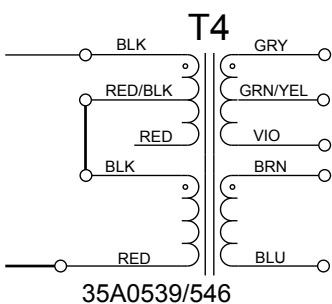

"T4" CONTROL TX:

480V, 60HZ INPUT

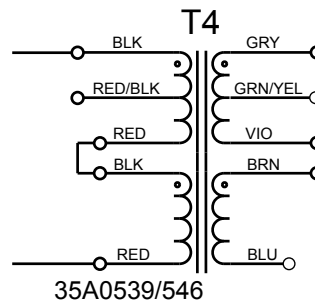

9.0 Troubleshooting



CAUTION

Allow only qualified personnel to perform the following tasks. Observe and follow the safety instructions in this document and all other related documentation.

De-energize regulator by turning the rotary switch to OFF, and remove input power to regulator by turning off disconnect switch or main circuit breaker.

Discharge capacitors and ground output terminals bushings by using a grounding rod prior to touching any parts.

If the regulator de-energizes, the output circuit could be interrupted by an overcurrent, open-circuit, or under-voltage condition. Before inspecting the output circuit.

Place the rotary selector switch in the OFF position and turn off disconnect switch or main circuit breaker. Without this precaution, a dip in the power line may reset the regulator and turn it on, resulting in an output voltage of thousands of volts which can cause serious injury or death.

Short the output terminals before switching the regulator on. The wire should be AWG 6 or larger. You may also use the SCO cutout to short the regulator output.

9.1 General Troubleshooting Chart



CAUTION

Read the instructions in their entirety before starting installation.

Only personnel authorized to work on high-voltage equipment should perform maintenance on the regulator.

Since high open-circuit voltages may result by opening the primary of a series lighting circuit, only personnel authorized to work on high-voltage equipment should be allowed to perform the open-circuit test.

Operating a regulator for long periods of time while seriously overloaded may cause the regulator to overheat.

This subsection provides general troubleshooting procedures for the L-828 CCR.

Table 22: CCR Troubleshooting

Problem	Possible Cause	Corrective Action
1. Regulator not turning on	Main power supply off	Verify presence of input voltage.
	Switched off due to overcurrent	Switch regulator off in local. Wait for 2 seconds and check to see if the regulator now operates correctly.
	Incorrect external wiring	If the regulator works correctly in local but not in Remote, check the Remote control signals.
	Blown fuse	Replace any blown fuse. Check the input supply voltage and make sure that it is between -5% and +10% of the nominal value listed on the CCR nameplate.
	Defective Control PCB	Replace Control PCB.
2. Regulator turns on but de-energizes suddenly	Output circuit interrupted	Apply a short to the regulator output. Turn the regulator on. If the regulator works correctly, repair the lighting circuit. Follow all safety precautions in this manual.
	Defective printed circuit board	Replace regulator controller.
	Overcurrent condition	Verify that SCR is triggering by replacing the PCB.
		Check feedback transformer T5 for damage and proper connections. Polarity does not affect operation. Compare input voltages across J8-4 to J8-3 with those in "Output Current Monitor Circuitry" on page 5. If the voltage at the terminals is correct for the selected step and the output is not correct, and the difference cannot be corrected by calibrating the regulator as specified in <i>Output Current Adjustment</i> in the Operation section.
	Check SCRs and wiring.	

Table 22: CCR Troubleshooting

Problem	Possible Cause	Corrective Action
		Replace SCR. Refer to Problem #11 in this table.
3. Output Current always 6.6 A/20 A or more	Universal regulator controller not calibrated	Calibrate the CCR as shown in “CCR Adjustment Procedures” on page 24. Check remaining steps to verify the values from “Output Current and Limits” on page 12.
	Overcurrent condition	Refer to problem #2 in this table, <i>Regulator turns on but de-energizes suddenly.</i>
4. Output Current always 4.8 A or less for 3-Step CCR or 2.8 A or less for 5-Step CCR or 8.5 or less on 20 A	Defective control board	If problem exists in Remote and local control, replace regulator controller.
	SCRs always conducting	Verify SCR is triggering by replacing PCB. Check SCRs and wiring for shorts in SCR circuitry. Replace SCR.
	Defective Ferroresonant resonant circuit (transformer or capacitor)	Visually inspect capacitors for damaged housing or wire connections. Visually inspect transformer for damaged coils, connections, and/or wiring. Faulty capacitors will exhibit a bulging case.
	CCR overload	Remove section of load.
5. More than 2 seconds required for CCR to de-energize on open-circuit load	Faulty overcurrent protection	Replace Control PCB .
6. Short lamp life and/or high output current reading on panel ammeter	Incorrect output current adjustment	Calibrate the CCR as shown in “CCR Adjustment Procedures” on page 24.
	Faulty overcurrent protection	Replace Control PCB .
7. Regulator not indicating proper current	Incorrect output current adjustment	Refer to Output Current Adjustment in the Operation section. Refer to Problem #11 in this table.
	Current meter not calibrated or faulty	Turn the regulator to the top step (6.6 A/20 A). Verify the current with a True-RMS current meter. If the meter is not accurate, adjust the meter with the screw on the front cover. For systems equipped with ACE, refer to: <ul style="list-style-type: none"> ▪ Advanced Control Equipment (ACE) manual 96A0287 or ▪ Advanced Control Equipment (ACE2) manual 96A0357 for display calibration procedures. ▪ ACE3 ä Manual 96A0500 Refer to Problem #11 in this table.
8. Regulator operates by the local control switch but not by Remote control	The rotary switch on the input module not set to REM	Set the rotary switch to REM.
	Blown fuse	Check fuse F5.
	Loose or broken Remote control wires	Check connections on Remote terminal block TB1. If 120 Vac Remote control signals are used, use an AC voltmeter (300 Vac scale) to verify correct signals are received at the CCR.
	Incorrect wire connections	Refer to Table 12 through Table 14.
9. Ammeter on CCR oscillates and loud noise occurs	SCR drive not working properly	Check connections at SCR module. Replace Control PCB . Refer to Problem #11 in this table.
Problem	Possible Cause	Corrective Action

Table 22: CCR Troubleshooting

Problem	Possible Cause	Corrective Action
10. Output current not able to be adjusted up to 6.6 A/ 20 A	Regulator load too large	<p>Either reduce the load or replace the regulator with a larger kW CCR.</p> <p>When overloaded, the regulator may make a faint bouncing sound as the controller bounces against the upper control limits.</p> <p>NOTE: This problem can also be verified by shorting the output of the CCR and verifying output current can be adjusted correctly in each step.</p>
11. 5-Step regulator (in Steps 1 or 2) emitting loud hum, not indicating proper current, and operating erratically	Light inductive load (for example, signs)	<p>Increase load on regulator.</p> <p>If you cannot increase the load, verify that you are dealing with the right problem by placing a current clamp on the output of the regulator and measuring the frequency of the output.</p> <p>Investigate to see if the problem occurs in Highest Step</p>

9.2 Preliminary Troubleshooting

The following is a check list of initial steps to perform.

- Visually examine all areas of the CCR. Do burnt or loose connections/parts exist?
- Is the input voltage present and within +10 to -5% of nominal?
- Check all the fuses.
- Are the wire harness connectors to the control board fully seated? Tighten only the wire connection screw within the regulator to insure that there are no potential issues with loose wiring.
- Have the PCBs been adjusted in accordance with the instruction manual?
- If the CCR works in local but not Remote, check the voltage on the Remote control lines.
- Can the CCR be re-energized by turning the rotary switch from OFF to Step B1 (B10)?
- Short the output of the CCR, and turn on the CCR. If the regulator operates normally, the problem is probably load related.
- If the CCR turns on and then shuts off after a few seconds and the ammeter has a high current reading, the problem is over-current. Adjust the output current accordingly. If the output current is not adjustable, replace the control board and restart the regulator.



Note

If the CCR still fails in over-current, replace the SCR and restart.

9.3 Troubleshooting Control Board

Figure 48: The URC4 Control Board

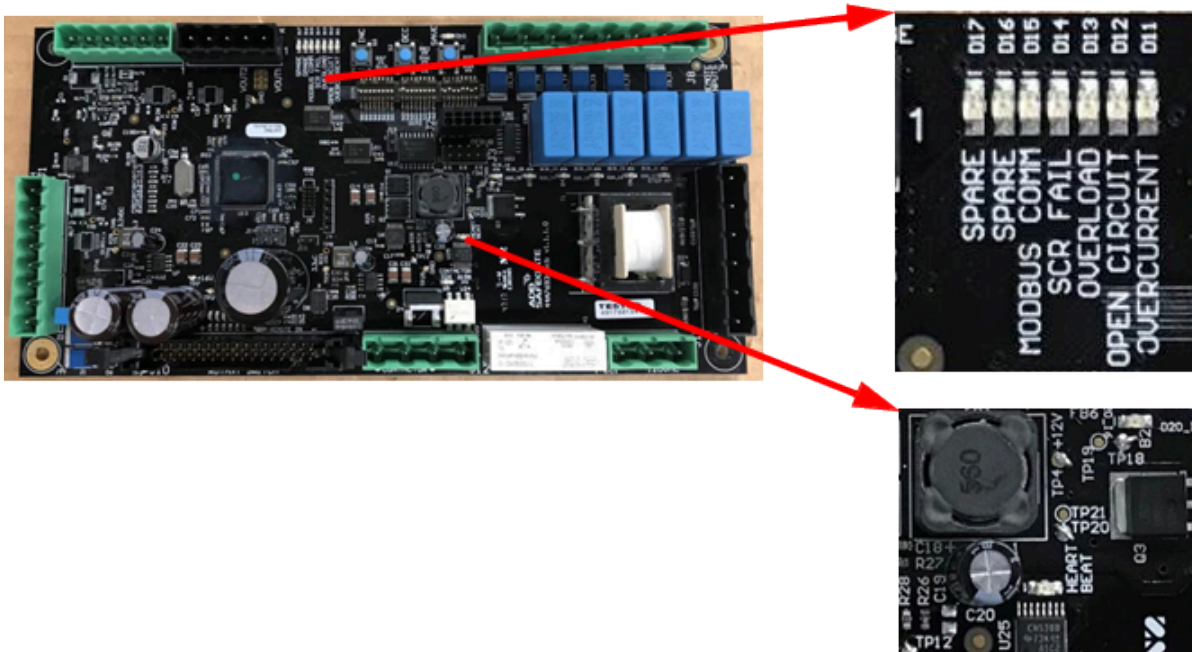

Table 23: Diagnostic LEDs on the Control Board

LED	Indication	Description
Heartbeat	Heartbeat	Will flash continuously in normal operation
D14	SCR Failure	Indicates that the SCR has failed
D13	Output Overload	CCR is overloaded
D12	Output Open Circuit	CCR has detected an open circuit
D11	Output Over Current	CCR has detected and over current condition
D15	Modbus Comm	Indicates the communication between the URC4 board and the ACE3 Unit
D16	SPARE	Save Pending
D17	SPARE	Unstable Input Power
D10	Save	Indicates the step current has been saved during calibration
D26	ON	K1 Contactor is Closed

Table 24: Remote Input Status

LED	Indication	Description
D23	ON	Indicates the Local Switch is in Remote
D20_12 (On)	ON	CC is active
D20_13 (B5)	ON	B5 is active
D20_14 (B4)	ON	B4 is active
D20_15 (B3)	ON	B3/B100 is active
D20_16 (B2)	ON	B2/B30 is active

10.0 CRF Parts

10.1 Ordering Code

Ordering Code

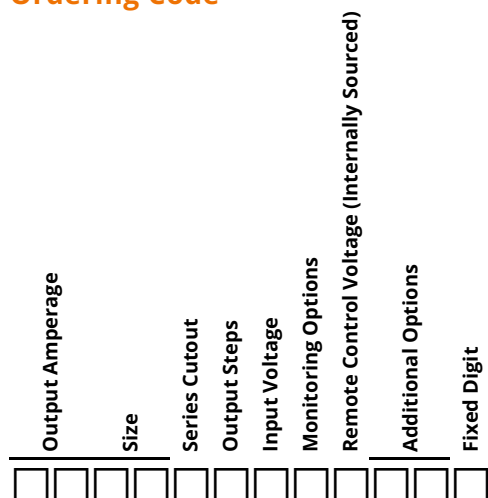

Output Amperage

66 = 6.6 A max

20 = 20 A max

Size

02 = 2.5 kW (6.6 A only)

04 = 4 kW (6.6 A only)

05 = 5 kW (6.6 A only)

07 = 7.5 kW (6.6 A only)

10 = 10 kW (6.6 A only)

15 = 15 kW

20 = 20 kW

25 = 25 kW

30 = 30 kW

Series Cutout

N = No Cutout

A = With Cutout¹

Output Steps

3 = 3-step²

5 = 5-step

Input Voltage

A = 208, 60 Hz (6.6A only)

B = 220, 60 Hz (6.6A only)

C = 240, 60 Hz

D = 347, 60 Hz

E = 380, 60 Hz

F = 480, 60 Hz

G = 600, 60 Hz (6.6A only)³

H = 208, 50 Hz (6.6A only)³

I = 220, 50 Hz (6.6A only)³

J = 230, 50 Hz (6.6A only)³

K = 240, 50 Hz (6.6A only)³

L = 380, 50 Hz³

M = 400, 50 Hz³

Monitoring Options

0 = L-828 with Analog Meter

2 = L-828 / L-829 with ACE3

3 = L-828 / L-829 w/ACE3, IRMS, Input Power Monitor

Remote Control Voltage (Internally Sourced)

A = 120 VAC

B = +48 VDC

C = +24 VDC

Additional Options

00 = No Additional Options

01 = Output Current Sensing Relay

02 = Door Documentation Pocket

03 = Option 01 + Option 02

08 = Input Circuit Breaker

Fixed Digit

0 = 0

10.2 CCR Options and Kits

Various options and kits are available to customize CCRs for specific application requirements. To order a kit integrated in the CCR when ordered, please see the Additional Options section of the CCR ordering code. If a kit or kit combination you desire is not listed on the ordering code, please contact the ADB SAFEGATE sales department. Some kits can be ordered separately and installed by the customer or by ADB SAFEGATE Technical Service.

¹ Not ETL Certified in Sizes 20 - 30 kW with 6.6 A Output

² Not ETL Certified when combined with 20 A Output Amperage

³ Not ETL Certified.

CCR Option / Kit Description	Available in CCR Ordering Code	Part Number if Ordered and Shipped Separately
Current Sensing AC/DC Relay Kit	Yes	
Provides a dedicated dry contact contact closure if CCR output current is present. Max 250V AC/DC, Max 8A continuous.		
Door Documentation Pocket Kit	Yes	
Provides a pocket for CCR documentation on the inside of the front door.		
SCO Kit	Yes	94A0341
Kit is used to install an internal SCO Series Cutout (PN 1475.92.030)		

10.3 Spare Parts

To order spare parts, call ADB SAFEGATE Customer Service or your local representative. Use this parts list, and the accompanying illustrations, to describe and locate parts correctly. Please have your regulator part number (i.e. CRF6610N5F3A000) available when you call.

Part Number	Ref Des	Description	Location
EU00005-105-01	SCR	SCR assembly for 2.5–30 kW	Figure 49
35A0539	T4	Transformer for 2.5–10 kW, 208–480V	Figure 49
35A0546	T4	Transformer for 15–30 kW, 208–480V	Figure 49
35A0796	T4	Transformer for 2.5–30 kW, 600V	Figure 49
35A0548	T5	Output Current Sensor for 6.6A Output CCR	Figure 50
35A0528	T5	Output Current Sensor for 20A Output CCR	Figure 50
35A0631/100	T3	Input Current Transformer (L-829 with IRMS and Input Monitoring Only)	Figure 49
44A6397	IRMS	IRMS Insulation Resistance Monitoring System PCB (L-829 with IRMS and Input Monitoring Only)	Figure 50
44A7693	URC	URC4 Control PCB	Figure 49
94A0341	SCO	Option: Series Cut Out (SCO)	Figure 49
See Table	F1-F4	Fuses: See Table 25	Figure 49
See Table	K2	Contactors: See Table 27	Figure 49
32A0115	VR1 VR2	Output Surge Arrestor for 2.5–10kW, 6.6A and ALL 20A	Figure 50
32A0114	VR1 VR2	Output Surge Arrestor for 15–30kW, 6.6A	Figure 50
94B0011	VR7 VR8	Input Surge Arrestor Assembly	Figure 49
72A0010	GND1	Ground Lug	Figure 52
45A0303	SW2	Door Interlock Switch, SPST 0.1A ON-OFF	Figure 52
60A4426	SW2	Door Interlock Switch Bracket	Figure 52
CALL	ACE3	ACE3 L-827/L-829 Monitor Assembly	Figure 51
44A6178	SW1	Door Switch Assembly, 3-Step	Figure 51
44A6178/5	SW1	Door Switch Assembly, 5-Step	Figure 51
61A0340	SW1	Door Switch Knob	Figure 51
52A0107	METER	L-828 Analog Ammeter 6.6A (L-828 Only)	Door (Not Shown)
52A0098	METER	L-828 Analog Ammeter 20A (L-828 Only)	Door (Not Shown)
35A0290	T2	Output Current Sensor for 6.6A Output CCR (L-282 Only)	Component Panel Rear (Not Shown)

Part Number	Ref Des	Description	Location
35A0308	T2	Output Current Sensor for 20A Output CCR (L-828 Only)	Component Panel Rear (Not Shown)
See Table	C1	Capacitor Bank	Rear of Frame (Not Shown)

Table 25: F1-F2 Fuses

CCR Size	208V	220V	240V	347V	380-400V	480V	600V
2.5 kW	47A0228, 20A 250V	47A0228, 20A 250V	47A0175, 15A 250V	47A0223, 10A 600V	47A0223, 10A 600V	47A0226, 8A 600V	47A0222, 6A 600V
4 kW	47A0092, 30A 250V	47A0092, 30A 250V	47A0069, 25A 250V	47A0191, 20A 600V	47A0191, 20A 600V	47A0090, 12A 600V	47A0223, 10A 600V
5 kW	47A0229, 35A 250V	47A0229, 35A 250V	47A0092, 30A 250V	47A0191, 20A 600V	47A0191, 20A 600V	47A0190, 17.5A 600V	47A0090, 12A 600V
7.5 kW	47A0093, 50A 250V	47A0093, 50A 250V	47A0070, 45A 250V	47A0193, 35A 600V	47A0085, 30A 600V	47A0091, 25A 600V	47A0191, 20A 600V
10 kW	47A0094, 70A 250V	47A0094, 70A 250V	47A0071, 60A 250V	47A0086, 40A 600V	47A0086, 40A 600V	47A0085, 30A 600V	47A0091, 25A 600V
15 kW	47A0099, 110A 250V	47A0099, 110A 250V	47A0083, 90A 250V	47A0087, 60A 600V	47A0087, 60A 600V	47A0088, 50A 600V	47A0086, 40A 600V
20 kW	47A0230, 150A 250V	47A0072, 125A 250V	47A0072, 125A 250V	47A0097, 90A 600V	47A0217, 80A 600V	47A0087, 60A 600V	47A0224, 45A 600V
25 kW	47A0101, 175A 250V	47A0101, 175A 250V	47A0230, 150A 250V	47A0227, 100A 600V	47A0097, 90A 600V	47A0217, 80A, 600V	47A0087, 60A, 600V
30 kW	47A0102, 200A 250V	47A0102, 200A 250V	47A0101, 175A 250V	47A0106, 125A 600V	47A0106, 125A 600V	47A0097, 90A 600V	47A0225, 70A, 600V

Table 26: F3-F4 Fuses

CRT Size (Voltage)	Part Number
2.5-10 kW (347-480V)	EZ00002-501-01: 500V, 1A
2.5-10 kW (208-240V)	EZ00002-502-01: 500V, 2A
15-30 kW (208-480V)	EZ00002-503-01: 500V, 3.15A
2.5-30 kW (600V)	EZ00002-601-01: 600V, 1A

Table 27: K2 Contactor

CCR Size	208-240V	347V	380-400V	480V	600V
2.5k W	53A0412/25	53A0412/25	53A0412/25	53A0412/25	53A0412/25
4k W	53A0412/30	53A0412/25	53A0412/25	53A0412/25	53A0412/25
5 kW	53A0412/40	53A0412/25	53A0412/25	53A0412/25	53A0412/25
7.5 kW	53A0412/50	53A0412/40	53A0412/40	53A0412/40	53A0412/25
10 kW	53A0412/75	53A0412/40	53A0412/40	53A0412/40	53A0412/25
15 kW	53A0412/120	53A0412/60	53A0412/60	53A0412/50	53A0412/40
20 kW	53A0412/150	53A0412/90	53A0412/90	53A0412/60	53A0412/50
25 kW	53A0412/150	53A0412/90	53A0412/90	53A0412/90	53A0412/60
30 kW	53A0331	53A0412/150	53A0412/150	53A0412/90	53A0412/75

Table 28: Capacitor Banks

CCR Size	60Hz Input	50Hz Input
2.5 kW	AS00034-100-01	AS00034-100-01
4 kW	AS00034-150-01	AS00034-200-01

Table 28: Capacitor Banks

CCR Size	60Hz Input	50Hz Input
5 kW	AS00034-150-01	AS00034-200-01
7.5 kW	AS00034-250-01	AS00034-300-01
10 kW	AS00034-300-01	AS00034-350-01
15 kW	AS00026-450-01	AS00026-550-01
20 kW	AS00026-600-01	AS00026-700-01
25 kW	AS00026-700-01	AS00026-850-01
30 kW	AS00026-850-01	AS00026-01K-01

10.4 Assembly Views

Figure 49: Component Plate (Front View)

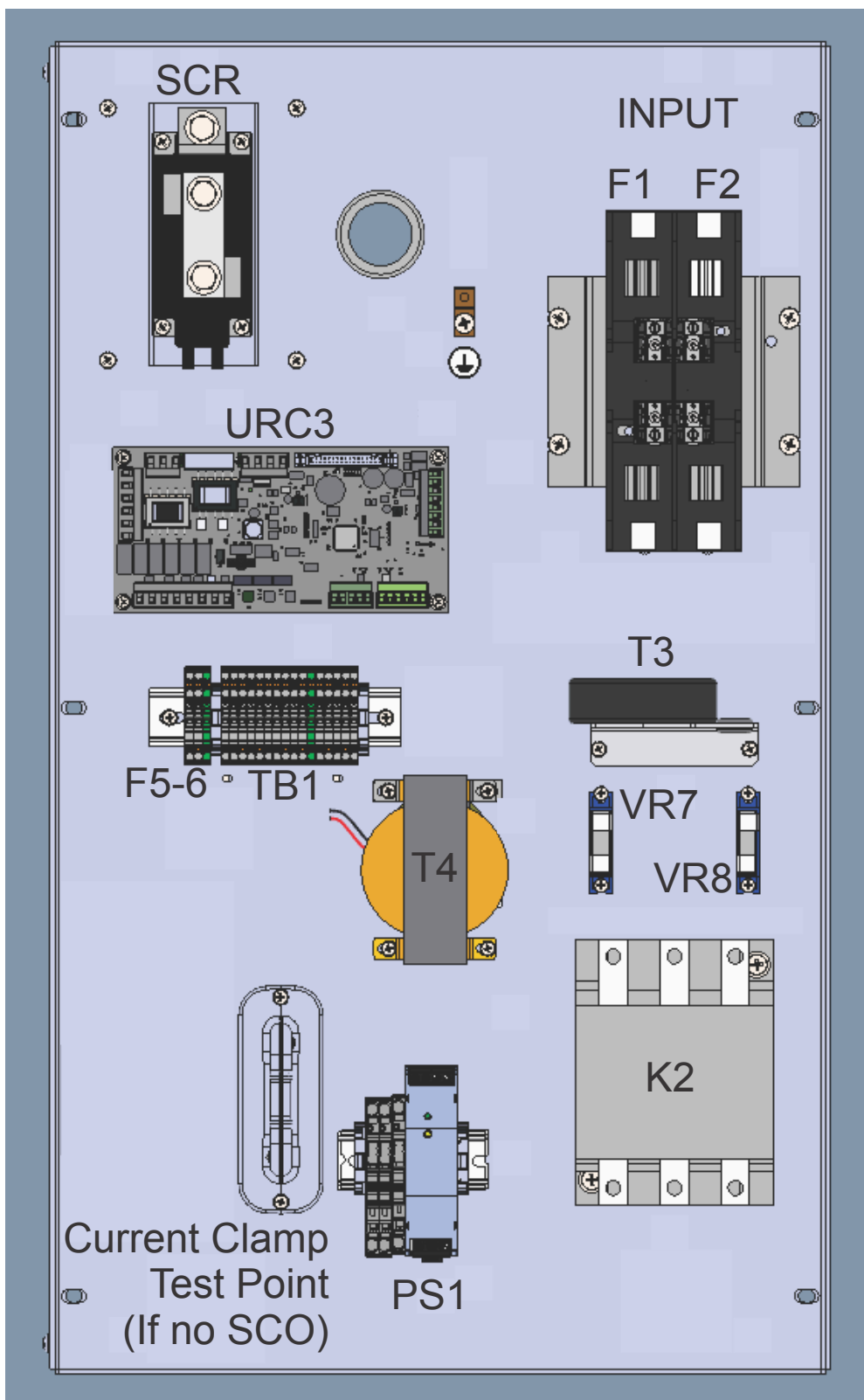

Figure 50: Component Plate (Rear View)

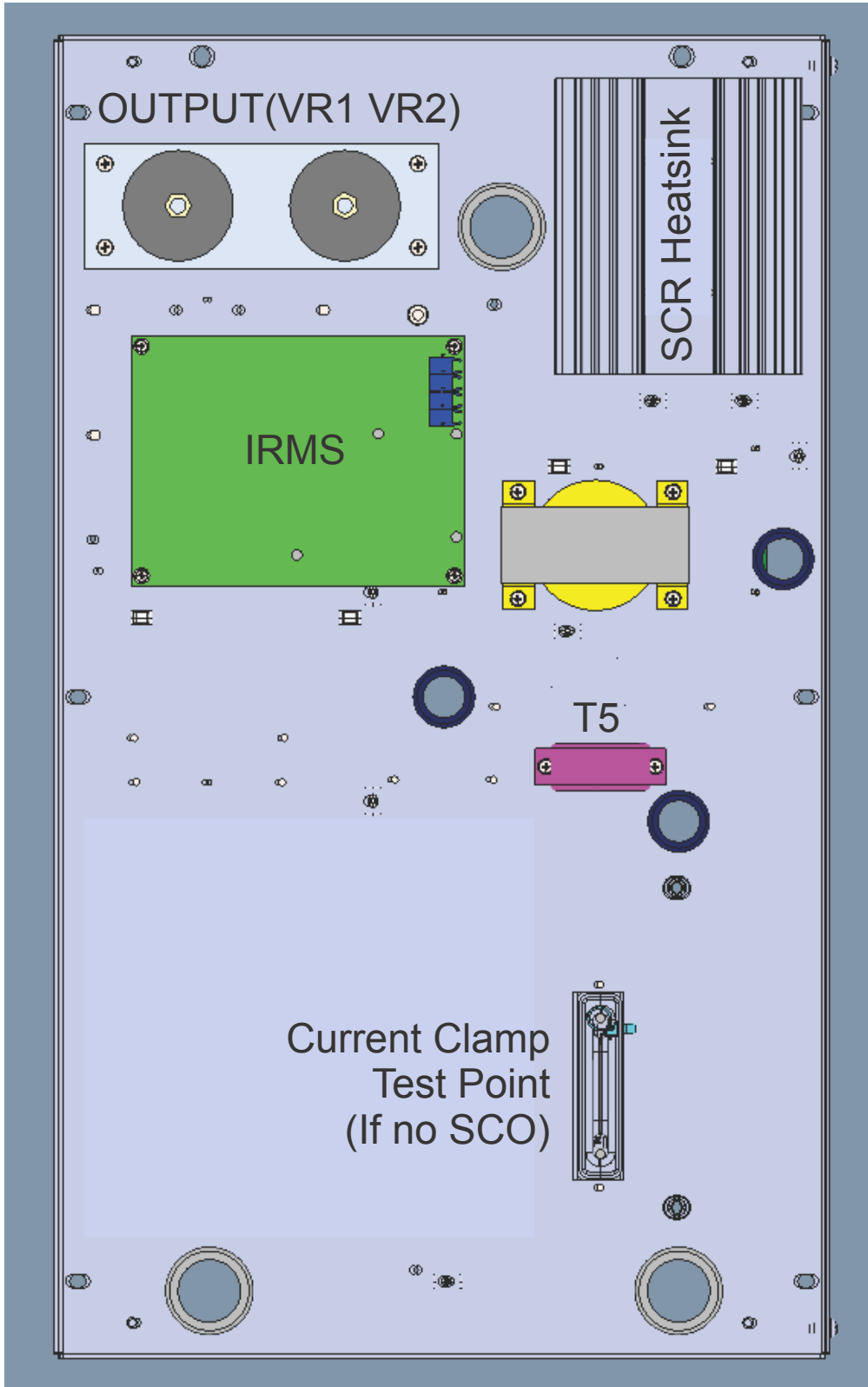

Figure 51: Door Parts (Internal View)

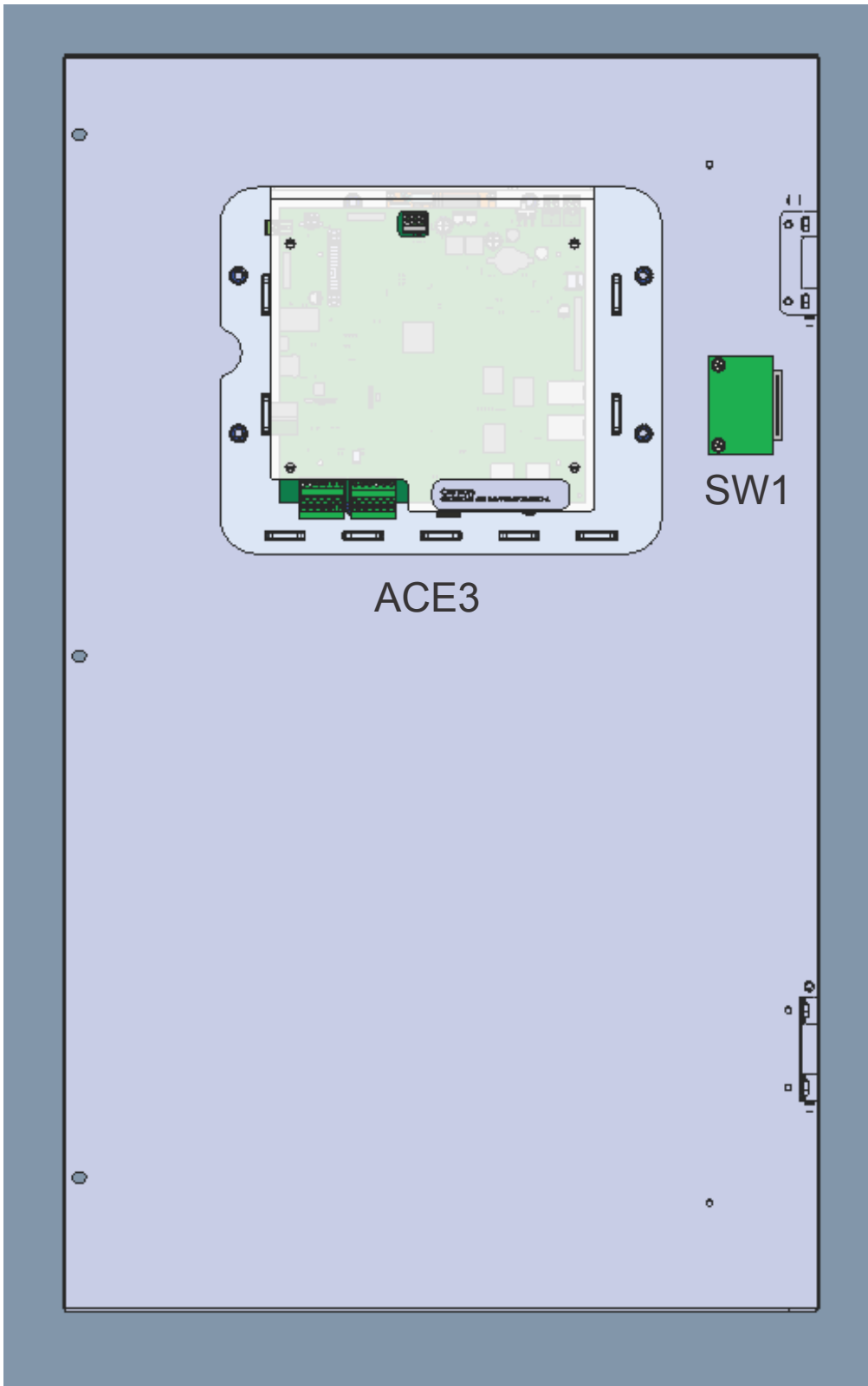
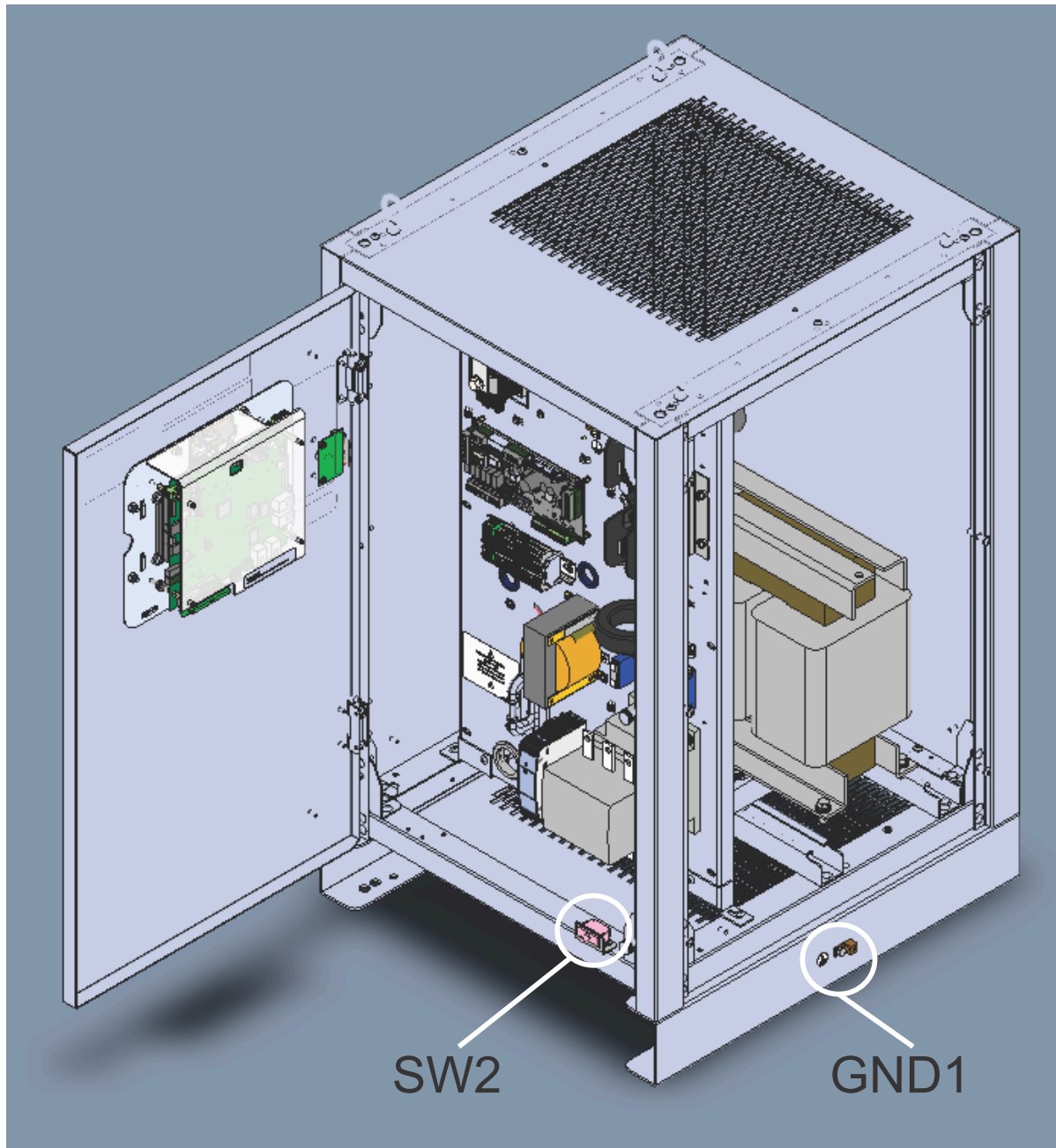

Figure 52: Assembly View (Door Open, Side Removed)



Appendix A: SUPPORT

Our experienced engineers are available for support and service at all times, 24 hour/7 days a week. They are part of a dynamic organization making sure the entire ADB SAFEGATE is committed to minimal disturbance for airport operations.

ADB SAFEGATE Support

Technical Support – Global

Customers in Europe, the Middle East, Africa or Asia Pacific are more than welcome to our portal for technical support. Trained in all areas of system issues, troubleshooting, quality control and technical assistance, our highly experienced Technical support specialists are available 24 hours a day, seven days a week to provide assistance over the phone. In the Americas, we also offer live technical support.

Live Technical Support – Americas

If at any time you have a question or concern about your product, contact ADB SAFEGATE's US-based technical support specialists, available 24 hours a day, seven days a week, to assist you via phone.

ADB SAFEGATE Americas Technical Service & Support (US & Canada) : **+1-800-545-4157**

ADB SAFEGATE Americas Technical Service & Support (Canada): **+1-905-631-1597**

ADB SAFEGATE Americas Technical Service & Support (International): **+1-614-861-1304**

We can also be reached via email during regular business hours:

Airfield and Gate: **techservice.us@adbsafegate.com**

Gate: **gateservice.us@adbsafegate.com**

We look forward to working with you!

Before You Call

When you have an airfield lighting or system control system problem, prior to calling, please ensure the following:

- Review the product's manual and troubleshooting guide.
- Be located with the product ready to troubleshoot.
- Have all necessary information available: airport code/company name, customer id number, contact phone number/email address, product/part number.
- Have a True RMS meter available and any other necessary tools.

When calling about an issue with Safedock A-VDGS, we can serve you better if you collect the following information before you call:

- Relevant information regarding the issue you are calling about, such as gate number, flight number, aircraft type and time of the event.
- What, if any, actions have been taken to resolve the issue prior to the call.
- If available, provide a CCTV recording of the incident to aid in aligning the information from the Safedock log file.

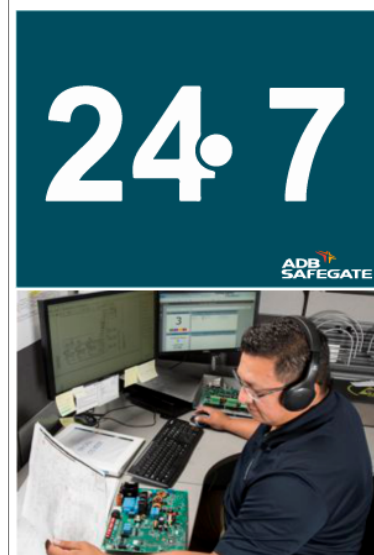

Note

For more information, see www.adbsafegate.com, contact ADB SAFEGATE Support via email at support@adbsafegate.com or Europe: +32 2 722 17 11

Americas: +1 614 861 1304. Press 3 for technical service or press 4 for sales support.

China: +86 (10) 8476 0106

Middle East and Africa: +971 4 452 7575

A.1 ADB SAFEGATE Website

The ADB SAFEGATE website, www.adbsafegate.com, offers information regarding our airport solutions, products, company, news, links, downloads, references, contacts and more.

A.2 Recycling

A.2.1 Local Authority Recycling

The disposal of ADB SAFEGATE products is to be made at an applicable collection point for the recycling of electrical and electronic equipment. The correct disposal of equipment prevents any potential negative consequences for the environment and human health, which could otherwise be caused by inappropriate waste handling. The recycling of materials helps to conserve natural resources. For more detailed information about recycling of products, contact your local authority city office.

A.2.2 ADB SAFEGATE Recycling

ADB SAFEGATE is fully committed to environmentally-conscious manufacturing with strict monitoring of our own processes as well as supplier components and sub-contractor operations. ADB SAFEGATE offers a recycling program for our products to all customers worldwide, whether or not the products were sold within the EU.

ADB SAFEGATE products and/or specific electrical and electronic component parts which are fully removed/separated from any customer equipment and returned will be accepted for our recycling program.

All items returned must be clearly labeled as follows:

- For RoHS/WEEE Recycling
- Sender contact information (Name, Business Address, Phone number).
- Main Unit Serial Number.

ADB SAFEGATE will continue to monitor and update according for any future requirements for EU directives as and when EU member states implement new regulations and or amendments. It is our aim to maintain our compliance plan and assist our customers.

Company Addresses

ADB SAFEGATE, Belgium	ADB SAFEGATE BV Leuvensesteenweg 585 B-1930 Zaventem Belgium
Contact:	
Tel.: +32 2 722 17 11	Email: marketing@adbsafegate.com
Fax: +32 2 722 17 64	Internet: www.adbsafegate.com
ADB SAFEGATE, Americas	ADB SAFEGATE Americas, LLC 700 Science Blvd Gahanna, OH 43230 USA
Contact:	
Tel.: +1 (614) 861 1304	Email: sales.us@adbsafegate.com
Fax: +1 (614) 864 2069	Internet: www.adbsafegate.com
ADB SAFEGATE, Sweden	ADB SAFEGATE Sweden AB Djurhagegatan 19 SE-213 76 Malmö Sweden
Contact:	
Tel.: +46 (0)40 699 17 00	Email: marketing@adbsafegate.com
Fax: +46 (0)40 699 17 30	Internet: www.adbsafegate.com
ADB SAFEGATE, China	ADB SAFEGATE Airfield Technologies Ltd. China Unit 603, D Block, CAMIC International Convention Center, No 3, Hua Jia Di East road, ChaoYang district, Beijing 100102 P.R. China
Contact:	
Tel.: +86 (10) 8476 0106	Email: china@safegate.com
Fax: +86 (10) 8476 0090	Internet: www.adbsafegate.com
ADB SAFEGATE, Germany	ADB SAFEGATE Germany GmbH Konrad-Zuse-Ring 6, D-68163 Mannheim Germany
Contact:	
Tel.: +49 (621) 87 55 76-0	Email: marketing@adbsafegate.com
Fax: +49 (621) 87 55 76-55	Internet: www.adbsafegate.com

WWW.ADBSAFEGATE.COM

Empowering the Airside Evolution

SMARTER. BETTER. NOW.



Copyright ©2021—2025 ADB SAFEGATE, All Rights Reserved