



RELIANCE Omni Protected 8-inch

## User Manual

UM-5027, Rev. 1.6, 2024/02/13

  
**ADB  
SAFEGATE**



# TABLE OF CONTENTS

<b>1.0 Safety</b> .....	<b>1</b>
1.1 Safety Messages .....	1
1.1.1 Introduction to Safety .....	2
1.1.2 Intended Use .....	3
1.1.3 Material Handling Precautions: Storage .....	3
1.1.4 Operation Safety .....	3
1.1.5 Maintenance Safety .....	4
1.1.6 Material Handling Precautions: Fasteners .....	4
1.1.7 Material Handling Precautions, ESD .....	5
<b>2.0 About this Manual</b> .....	<b>7</b>
2.1 How to work with the manual .....	7
2.2 Abbreviations and terms — AGL .....	7
2.3 Abbreviations and Terms .....	7
<b>3.0 General Information</b> .....	<b>9</b>
3.1 Introduction to RELIANCE .....	9
3.2 LED Apron Maneuvering .....	10
3.3 LED Taxiway Edge .....	11
<b>4.0 Installation</b> .....	<b>13</b>
4.1 Unpacking the Unit .....	13
4.2 Tools required .....	13
4.3 Installation and Removal of the 8-inch Light Fixture .....	14
<b>5.0 Operation</b> .....	<b>17</b>
<b>6.0 Maintenance</b> .....	<b>19</b>
6.1 Safety Instructions .....	19
6.2 Safety Considerations .....	20
6.3 Basic Maintenance Program .....	20
6.4 Workshop Maintenance .....	21
6.4.1 Disclaimer / Standard Warranty .....	21
6.4.2 Exploded View .....	24
6.4.3 Opening a 8-inch Fixture .....	25
6.4.4 Closing a 8-inch Fixture .....	25
6.4.5 Checking the Light Fixture for Watertightness .....	27
6.4.6 Replacing a Light Engine in a 8-inch Fixture .....	28
6.4.7 Replacing the Top Cover .....	30
6.4.8 Replacing the Connection Board .....	32
6.4.9 Replacing the LED Board .....	34
6.4.10 Replacing a Prism, Gaskets and Blue Spacers (Prism Protection Plates) in a 8-inch Fixture .....	34
6.4.11 Replacing the Bottom Cover and Converter .....	38
6.4.12 Resetting the Fail-open converter 2.3 .....	39
6.4.13 Resetting the Fail-open converters 48010921 and 48011111 .....	40
<b>7.0 Spare Parts</b> .....	<b>41</b>
7.1 Ordering Code Apron Maneuvering .....	41
7.2 Ordering Code Taxiway Edge .....	42
7.3 Components .....	43
7.4 Screws Overview .....	43

<b>A.0 INTEROPERABILITY .....</b>	<b>45</b>
<b>B.0 POWER TABLE .....</b>	<b>47</b>
<b>C.0 CABLE LOSS .....</b>	<b>49</b>
<b>D.0 SUPPORT .....</b>	<b>51</b>
D.1 ADB SAFEGATE Website .....	51
D.2 Recycling .....	51
D.2.1 Local Authority Recycling .....	51
D.2.2 ADB SAFEGATE Recycling .....	51

# List of Figures

Figure 1: RELIANCE Omni, 4 prisms .....	9
Figure 2: In an 8-in base .....	13
Figure 3: In a 12-in base with adapter ring .....	13
Figure 4: Omnidirectional Light, 4 prisms, 8-inch .....	24
Figure 5: Fixture upside down .....	25
Figure 6: Lifting up housing .....	25
Figure 7: Removing gasket .....	25
Figure 8: Converter with 1 connector .....	26
Figure 9: Converter with 2 connectors .....	26
Figure 10: Fixture facing down .....	26
Figure 11: Tightening screws .....	27
Figure 12: Light engine replacement .....	29
Figure 13: Removing the LED board holder .....	29
Figure 14: Tightening screws .....	30
Figure 15: LED board .....	30
Figure 16: Top cover with bottom cover .....	31
Figure 17: Replacing the connection board .....	32
Figure 18: Two connector types (replaceable) .....	33
Figure 19: Red and black cable connections .....	33
Figure 20: LED sub assembly (Optical assembly) .....	34
Figure 21: Exploded view - prism replacement .....	35
Figure 22: Remove LED board holder .....	35
Figure 23: Remove prism and gasket .....	36
Figure 24: New prism into prism gasket .....	36
Figure 25: Prism holder edge .....	37
Figure 26: Tighten screws in sequence .....	37
Figure 27: Correct gasket position .....	37
Figure 28: Converter with 1 connector .....	39
Figure 29: Converter with 2 connectors .....	39
Figure 30: 2-way electrical shunt / jumper .....	39
Figure 31: Converter with 1 connector .....	39
Figure 32: Converter with 2 connectors .....	39
Figure 33: Converter with 1 connector .....	40
Figure 34: Converter with 2 connectors .....	40



## List of Tables

Table 1: Legend Exploded View .....	24
Table 2: Interoperability matrix .....	45





# 1.0 Safety

## Introduction to Safety

This section contains general safety instructions for installing and using ADB SAFEGATE equipment. Some safety instructions may not apply to the equipment in this manual. Task- and equipment-specific warnings are included in other sections of this manual where appropriate.

## 1.1 Safety Messages

### HAZARD Icons used in the manual

For all HAZARD symbols in use, see the Safety section. All symbols must comply with ISO and ANSI standards.

Carefully read and observe all safety instructions in this manual, which alert you to safety hazards and conditions that may result in personal injury, death or property and equipment damage and are accompanied by the symbol shown below.



**WARNING**  
Failure to observe a warning may result in personal injury, death or equipment damage.



**DANGER - Risk of electrical shock or ARC FLASH**  
Disconnect equipment from line voltage. Failure to observe this warning may result in personal injury, death, or equipment damage. ARC Flash may cause blindness, severe burns or death.



**WARNING - Wear personal protective equipment**  
Failure to observe may result in serious injury.



**WARNING - Do not touch**  
Failure to observe this warning may result in personal injury, death, or equipment damage.



**CAUTION**  
Failure to observe a caution may result in equipment damage.



**ELECTROSTATIC SENSITIVE DEVICES**  
This equipment may contain electrostatic devices.

## Qualified Personnel



### Important Information

The term **qualified personnel** is defined here as individuals who thoroughly understand the equipment and its safe operation, maintenance and repair. Qualified personnel are physically capable of performing the required tasks, familiar with all relevant safety rules and regulations and have been trained to safely install, operate, maintain and repair the equipment. It is the responsibility of the company operating this equipment to ensure that its personnel meet these requirements.

Always use required personal protective equipment (PPE) and follow safe electrical work practice.

### 1.1.1 Introduction to Safety

## CAUTION

### Unsafe Equipment Use

This equipment may contain electrostatic devices, hazardous voltages and sharp edges on components

- Read installation instructions in their entirety before starting installation.
- Become familiar with the general safety instructions in this section of the manual before installing, operating, maintaining or repairing this equipment.
- Read and carefully follow the instructions throughout this manual for performing specific tasks and working with specific equipment.
- Make this manual available to personnel installing, operating, maintaining or repairing this equipment.
- Follow all applicable safety procedures required by your company, industry standards and government or other regulatory agencies.
- Install all electrical connections to local code.
- Use only electrical wire of sufficient gauge and insulation to handle the rated current demand. All wiring must meet local codes.
- Route electrical wiring along a protected path. Make sure they will not be damaged by moving equipment.
- Protect components from damage, wear, and harsh environment conditions.
- Allow ample room for maintenance, panel accessibility, and cover removal.
- Protect equipment with safety devices as specified by applicable safety regulations
- If safety devices must be removed for installation, install them immediately after the work is completed and check them for proper functioning prior to returning power to the circuit.



**Failure to follow this instruction can result in serious injury or equipment damage**

### Additional Reference Materials

---



#### Important Information

- IEC - International Standards and Conformity Assessment for all electrical, electronic and related technologies.
  - IEC 60364 - Electrical Installations in Buildings.
  - CSA - C22.2 No.180:13 (R2018) Series isolating transformers for airport lighting
  - FAA Advisory: AC 150/5340-26 (current edition), Maintenance of Airport Visual Aid Facilities.
  - Maintenance personnel must refer to the maintenance procedure described in the ICAO Airport Services Manual, Part 9.
  - ANSI/NFPA 79, Electrical Standards for Metalworking Machine Tools.
  - National and local electrical codes and standards.
-

### 1.1.2 Intended Use



#### CAUTION

##### Use this equipment as intended by the manufacturer

This equipment is designed to perform a specific function, do not use this equipment for other purposes

- Using this equipment in ways other than described in this manual may result in personal injury, death or property and equipment damage. Use this equipment only as described in this manual.

**Failure to follow this instruction can result in serious injury or equipment damage**

### 1.1.3 Material Handling Precautions: Storage



#### CAUTION

##### Improper Storage

Store this equipment properly

- If equipment is to be stored prior to installation, it must be protected from the weather and kept free of condensation and dust.

**Failure to follow this instruction can result in equipment damage**

### 1.1.4 Operation Safety



#### CAUTION

##### Improper Operation

Do Not Operate this equipment other than as specified by the manufacturer

- Only qualified personnel, physically capable of operating the equipment and with no impairments in their judgment or reaction times, should operate this equipment.
- Read all system component manuals before operating this equipment. A thorough understanding of system components and their operation will help you operate the system safely and efficiently.
- Before starting this equipment, check all safety interlocks, fire-detection systems, and protective devices such as panels and covers. Make sure all devices are fully functional. Do not operate the system if these devices are not working properly. Do not deactivate or bypass automatic safety interlocks or locked-out electrical disconnects or pneumatic valves.
- Protect equipment with safety devices as specified by applicable safety regulations.
- If safety devices must be removed for installation, install them immediately after the work is completed and check them for proper functioning.
- Route electrical wiring along a protected path. Make sure they will not be damaged by moving equipment.
- Never operate equipment with a known malfunction.
- Do not attempt to operate or service electrical equipment if standing water is present.
- Use this equipment only in the environments for which it is rated. Do not operate this equipment in humid, flammable, or explosive environments unless it has been rated for safe operation in these environments.
- Never touch exposed electrical connections on equipment while the power is ON.

**Failure to follow these instructions can result in equipment damage**

### 1.1.5 Maintenance Safety

#### DANGER

##### Electric Shock Hazard

This equipment may contain electrostatic devices

- Do not operate a system that contains malfunctioning components. If a component malfunctions, turn the system OFF immediately.
- Disconnect and lock out electrical power.
- Allow only qualified personnel to make repairs. Repair or replace the malfunctioning component according to instructions provided in its manual.
- 



**Failure to follow these instructions can result in death or equipment damage**

### 1.1.6 Material Handling Precautions: Fasteners



#### DANGER

##### Foreign Object Damage - FOD

This equipment may contain fasteners that may come loose - torque properly.

- Only use fasteners of the same type as the one originally supplied with the equipment.
- Use of incorrect combination of gaskets, bolts and nuts can create severe damages to the product installation and create safety risk .
- You need to know what base the light fixture will be installed in, in order to chose the correct gasket, bolts and nuts.
- Bolt type, length, and torque value are determined by type of base, height of spacers used, and clamp force required in FAA Engineering Brief No 83 (latest revision).
- Due to the risk of bolts vibrating loose, do not use any type of washer with the fixing bolts (such as split lock washers) other than an anti-vibration washer. Anti-vibration washers as defined in FAA EB 83 (latest edition) must be used. For installations other than FAA, use the base can manufacturer's recommendations.
- Always tighten the fasteners to the recommended torque. Use a calibrated torque wrench and apply the recommended adhesive type.
- Obey the instructions of the adhesives necessary for the fasteners.

**Failure to follow these warnings may cause the fasteners to loosen, damage the equipment, potentially to loosen the equipment. This can lead to a highly dangerous situation of FOD, with potential lethal consequences.**



#### Note

To minimize the risk of errors, the ADB SAFEGATE Sales Representative will have information on which gasket goes with which base. This information is also provided in the product Data sheets, the User Manuals and the Spare Part Lists.



#### CAUTION

Use of incorrect combination of gaskets, bolts and nuts can create severe damages to the product installation and create multiple safety risks.

To obtain a safe and watertight installation the O-ring and retaining bolt stated in the document must be used.

You need to know what base the light fixture will be installed in, in order to choose the correct gasket, bolts and nuts.

**Failure to follow these cautions can result in equipment damage or aircraft FOD.**

### 1.1.7 Material Handling Precautions, ESD



#### CAUTION

##### Electrostatic Sensitive Devices

This equipment may contain electrostatic devices

- Protect from electrostatic discharge.
- Electronic modules and components should be touched only when this is unavoidable e.g. soldering, replacement.
- Before touching any component of the cabinet you shall bring your body to the same potential as the cabinet by touching a conductive earthed part of the cabinet.
- Electronic modules or components must not be brought in contact with highly insulating materials such as plastic sheets, synthetic fiber clothing. They must be laid down on conductive surfaces.
- The tip of the soldering iron must be grounded.
- Electronic modules and components must be stored and transported in conductive packing.

**Failure to follow this instruction can result in equipment damage**



## 2.0 About this Manual

This document includes information on the RELIANCE omnidirectional 8-inch inset light fixture with a focus on safety, installation and maintenance procedures.

For more information, see [www.adbsafegate.com](http://www.adbsafegate.com).

### Note

It is very important to read this document before any work is started.

## 2.1 How to work with the manual

1. Become familiar with the structure and content.
2. Carry out the actions completely and in the given sequence.

## 2.2 Abbreviations and terms — AGL

Abbreviations and terms	Description
FAA	Federal Aviation Administration
ICAO	International Civil Aviation Organization
IEC	International Electrical Committee
ISO	International Standardization Organization
ANSI	American National Standards Institute
NFPA	National Fire Protection Association
AC	Advisory Circular (FAA)
ESD	Electro-Static Discharge; Electrostatic-Sensitive Devices
LED	Light Emitting Diode
PPE	Personal Protective Equipment
FOD	Foreign Object Debris
Mounting support	A piece of equipment, on which the fixture is installed.
Toe-in	The toe-in angle is the angle the beam of light makes with the longitudinal axis of the runway or taxiway.

## 2.3 Abbreviations and Terms

This document may include the abbreviations and terms listed below.

Abbreviation and term	Description
A-SMGCS	Advanced Surface Movement Guidance and Control System
CAA	Civil Aviation Authority
CCR	Constant Current Regulator
FAA	Federal Aviation Administration
ICAO	International Civil Aviation Organization
IEC	International Electrotechnical Committee
ILCMS	Individual Light Control and Monitoring System
LED	Light Emitting Diode

---

Abbreviation and term	Description
NATO	North Atlantic Treaty Organization
SMGCS	Surface Movement Guidance and Control System
SSU	System Switch Unit
STAC	Service Technique de l'Aviation Civile (France)
STANAG	Standardization Agreement (NATO)



## 3.0 General Information



### WARNING

Read installation instructions in their entirety before starting installation.

- Become familiar with the general safety instructions in this section of the manual before installing, operating, maintaining or repairing this equipment.
- Read and carefully follow the instructions throughout this manual for performing specific tasks and working with specific equipment.
- these warnings may result in serious injury or equipment damage.

Figure 1: RELIANCE Omni, 4 prisms

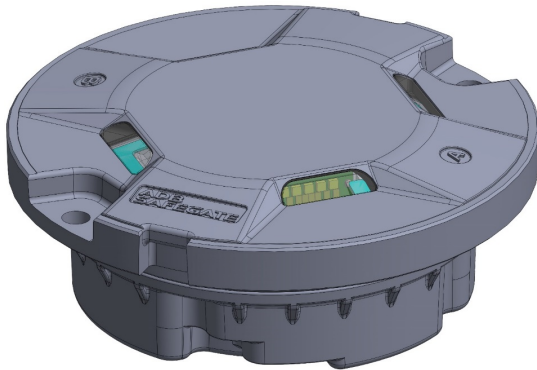

## 3.1 Introduction to RELIANCE

### RELIANCE – the all in one revolution

The RELIANCE omnidirectional light fixture is a low protrusion light-emitting diode (LED) fixture, available in three versions:

<b>RELIANCE NON-MON</b>	A LED light fixture without monitoring (No CCR monitoring or ILCMS compatibility)	
<b>RELIANCE MON</b>	A LED light fixture with integrated fail open technology with CCR monitoring compatibility	
<b>RELIANCE IQ</b>	A RELIANCE with additional and integrated intelligence (IQ) in a built-in converter for individual monitoring and control, based on RELIANCE Intelligent Light Control and Monitor System (ILCMS)	
<b>RELIANCE IQ0</b>	RELIANCE IQ light fixture with disabled IQ (ILCMS) functionality. Non-MON light fixture with possibility to activate IQ at a later stage	



### NOTICE

RELIANCE IQ light fixtures are not fail-open light fixtures. When IQ is activated the monitoring as well as the control functionality is handled by the ILCMS system.

## 3.2 LED Apron Maneuvering

### Compliance with Standards (current versions)

<b>ICAO</b>	Annex 14, Volume 1
<b>IEC</b>	61827
<b>EASA</b>	CS-ADR-DSN
<b>Canada</b>	TP 312
<b>Australia</b>	MOS 139
<b>CE</b>	

---

### Uses

The RELIANCE™ 8-inch omnidirectional low-protrusion inset LED light fixture is provided with red or yellow LEDs. This fixture can be used in the following applications:

- Aircraft Stand Maneuvering Guidance

### Features and Benefits

#### Efficiency

- RELIANCE IQ with integrated intelligence
- RELIANCE with integrated fail-open technology
- RELIANCE Non-MON, non monitored lights
- Operates on CCRs designed in compliance with IEC or FAA requirements
- Easy maintenance due to modular design, few mechanical parts
- No visual flicker. PWM is used for some applications to optimize the LED performance and light fixtures show no visual flickering.

#### Sustainability

- Light-emitting diode (LED) technology that offers a long-lasting light source with low power consumption
- IP68 protected, aluminum housing designed for harsh weather environments (all fastenings in stainless steel)
- Protected top cover for improved durability and protection from external forces
- Compatible with existing infrastructure
- Fixture compatible with all ADB SAFEGATE 8-inch bases

#### Safety

- Light engine protected against towbar impact and high load from maneuvering vehicles and aircrafts
- Shorted LED detection according to FAA Engineering Brief No.67D

### Accessories

Refer to the RELIANCE inset user manual for 8-inch lights.

### Power Supply

An integrated, encapsulated 6.6A electronic converter. Two-pole L-823 FAA Style 6 (2-pin) plug for connection to the transformer. Power factor typically > 0.95 at 6.6 A. Power consumption 35 W.

French (flat 3-pin) plugs are also available for the French market.



## Note

- Refer to the appendix of RELIANCE inset user manual for 8-inch lights for a complete power table and the cable loss formula.
- Refer to the annex section.

## Maintenance and Installation

Refer to the RELIANCE inset user manual for 8-inch lights UM-5027 and to the interoperability information for installation in a specific base.

## Dimensions and Weight

<b>Outer diameter / depth</b>	Approx.203 mm / 81.35 mm 8 in / 3.2 in3
<b>Weight without packaging</b>	Approx. 2.8 kg 6.1 lb

## Operating Conditions

<b>Operating temperature</b>	-60 °C to +55 °C / -76 °F to +131 °F
<b>Storage temperature</b>	-60 °C to +80 °C / -76 °F to +176 °F
<b>Relative humidity</b>	Up to 100%

- Deep base and / or adapter rings to be ordered separately.
- The IQ-functionality allows control and monitoring of the RELIANCE IQ. IQ1 fittings are pre-configured for the specific position at delivery. This function is disabled in IQ0 fittings but could be enabled in a later state. IQ light fixtures are only available as one connector option but both sides can be controlled individually if they are configured as IQ1 with an ILCMS.

For more information about the product, including manuals and certifications, please see our Product Center on the ADB SAFEGATE website: [www.adbsafegate.com](http://www.adbsafegate.com).

## 3.3 LED Taxiway Edge

### Compliance with Standards (current versions)

<b>FAA</b>	L-852T(L)
<b>ICAO</b>	Annex 14, Volume 1
<b>IEC</b>	61827
<b>EASA</b>	CS-ADR-DSN
<b>Canada</b>	TP 312
<b>Australia</b>	MOS 139
<b>US Navy</b>	NAVAIR 5150AAA-2, WP 006-04
<b>UFC</b>	3-535-01
<b>CE</b>	

## Uses

The RELIANCE™ 8-inch omnidirectional low-protrusion protected inset LED light fixture is provided with blue or yellow LEDs. This fixture can be used in the following applications:

- Taxiway Edge, L-852T(L)
- NAVAIR Edge
- UFC Edge
- Intermediate Holding Position (MOS)

## Features and Benefits

### Efficiency

- RELIANCE IQ with integrated intelligence
- RELIANCE with integrated fail-open technology
- RELIANCE Non-MON, non-monitored lights
- Operates on 3- or 5-step ferroresonant or thyristor CCRs designed in compliance with IEC or FAA requirements
- Easy maintenance due to modular design, few mechanical parts

### Sustainability

- Light-emitting diode (LED) technology that offers a long-lasting light source with low power consumption
- IP68 protected (all fastenings in stainless steel)
- Protected top cover for improved durability and protection from external forces
- Compatible with existing infrastructure
- Fixture compatible with all ADB SAFEGATE 8-inch bases

### Safety

- Light engine protected against towbar impact and high load from maneuvering vehicles and aircrafts
- Shorted LED detection according to FAA Engineering Brief No.67D

## Maintenance and Installation

Refer to the RELIANCE inset user manual UM-5027 for 8-inch lights and to the interoperability info for installation in a specific base.

## Dimensions and Weight

<b>Outer diameter / depth</b>	Approx. 203 mm / 81.35 mm 8 in / 3.2 in
<b>Weight without packaging</b>	Approx. 2.8 kg 6.1 lb

## Operating Conditions

<b>Operating temperature</b>	-60 °C to +55 °C / -76 °F to +131 °F
<b>Storage temperature</b>	-60 °C to +80 °C / -76 °F to +176 °F
<b>Relative humidity</b>	Up to 100%

For more information about the product, including manuals and certifications, please see our Product Center on the ADB SAFEGATE website: [www.adbsafegate.com](http://www.adbsafegate.com).

## 4.0 Installation

Install the inset light fixture in a base provided by ADB SAFEGATE as follows:

**Figure 2: In an 8-in base**

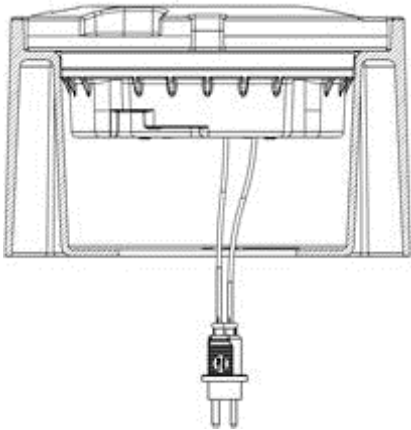

**Figure 3: In a 12-in base with adapter ring**

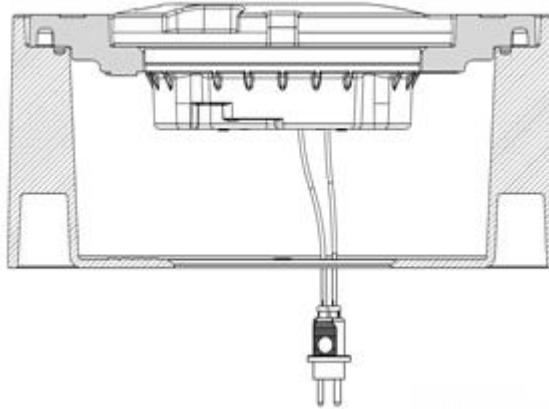

### NOTICE

If the inset light fixture is to be installed on another type of base or adapter ring not provided by ADB SAFEGATE, contact ADB SAFEGATE. The inset light fixture is fixed in the base by six M10 lock nuts or by six M10×25 or M10×22 bolts dependent on base installation.

### Important

Use of incorrect combination of gaskets, bolts and nuts can create severe damages to the product installation and create multiple safety risks.

To obtain a safe and watertight installation the O-ring and retaining bolt stated in the document must be used.

You need to know what base the light fixture will be installed in, in order to choose the correct gasket, bolts and nuts.

## 4.1 Unpacking the Unit

To reduce the possibility of damaging the light assembly, unpack the light fixtures at the installation site. If damage to any equipment is noted, file a claim form with the carrier immediately.

When receiving the light fixture, open the box and verify that the characteristics of the light fixture correspond to the design requirements, such as type, color etc. When installing a light fixture where the control and monitoring function is to be activated at a later stage, make sure to register product information, such as PID/SN and position of the light fixture in, for example, a site documentation table. The information is required for remote activation and administration of control and monitoring functionality from a substation.

## 4.2 Tools required

The following tools are recommended for installation.

- One Box spanner 16/17 mm
- One torque wrench with a 16/17 mm socket
- Two large flat headed screwdrivers for lifting the light fixture
- One T20 Torx key
- One brush or cloth
- One 3 mm Allen key



### Note

Provided that the base intended to receive the light fixture has been properly installed, no other specific tool is required.

---

## 4.3 Installation and Removal of the 8-inch Light Fixture

### Installing the light fixture in a FAA deep base

Installation instructions for the inset light fixtures as follows:

- Light bases shall be installed with care to assure vertical and azimuth alignment of fixture.
  - Provide 60–90 cm / 2–3-foot cable slack within light base to allow transformer servicing.
  - The minimum thread engagement into top flange of base is 127 mm (0.5 inch).
  - As required to maintain +0/ through -1/16-inch below grade FAA installation tolerance, a maximum of three spacer rings may be stacked together. Refer to section.
1. Carefully clean all contact surfaces of the light fixture and the base.
  2. Put the correct gasket (O-ring or labyrinth gasket) on the inner cover of the light. Refer to the [INTEROPERABILITY](#) appendix for this fixture.
  3. Connect the connector(s) of the light fixture to the base supply cable(s). Check that the A- and B-side are connected to corresponding circuit if two connectors are used.
  4. Place the connector under the light fixture and install on the base.
  5. For an installation on bases, use a torque limiting box spanner of 16/17 mm, install and tighten the two fixing bolts or nuts to a torque value according to specification, refer to [INTEROPERABILITY](#) appendix. For other base manufacturers, refer to their specifications.
- 

### Restriction

Do not use high speed for tightening, the recommended speed is 10 - 40 rpm. Do not use an impact driver/wrench.

---

6. After installation, check that each light fixture functions properly.
7. In order to bond the light fixture to ground, use the supplied screw (Torx M4×6 mm, Torque 2.5 Nm) to attach the braided ground strap to the grounding point on the light fixture. The grounding point is indicated by a grounding symbol and located on the bottom side.

### Removing the fitting from the base

---



### CAUTION

Fall- and trip hazard! When a light fixture has been removed, the base must be fitted with a cover designed for this purpose or with a spare light fixture.

---

1. Remove the light fixture from the base using two large flat blade screwdrivers.
  2. Disconnect the secondary supply connector.
  3. Remove and check the gasket (O-ring or labyrinth).
- 



### Note

It is recommended to change the gasket, lock nuts or bolts each time the light fixture is removed or dismantled from the base. For more information, refer to [INTEROPERABILITY](#) appendix.

---



## CAUTION

Use of incorrect combination of gaskets, bolts and nuts can create severe damages to the product installation and create multiple safety risks.

Make sure to know what base the light fixture will be installed in, in order to chose the correct gasket, bolts and nuts. Failure to follow these cautions can result in equipment damage or aircraft FOD. For more information, see [INTEROPERABILITY](#).

---





---

## 5.0 Operation

Refer to the UM-0600 and other documentation related to RELIANCE IL on our Product Center if you are using an IQ light fixture. Refer to [adbsafegate.com/product-center/airfield/](https://adbsafegate.com/product-center/airfield/) for further info.



## 6.0 Maintenance

This section describes different steps for maintenance of the light fixture.

Before you start, make sure you have read and understand [Safety Instructions](#).

Find out the location of the light unit that needs maintenance. If the purpose is to replace an existing light unit with new one, make sure that corresponding unit is available. Find the type information on the identification tag with details of name.

Spare parts are available, if required. For more information, see [www.adbsafegate.com](http://www.adbsafegate.com) and the Spare Parts List document, or contact ADB SAFEGATE for assistance.

### Important

Use of incorrect combination of gaskets, bolts and nuts can create severe damages to the product installation and create multiple safety risks.

You need to know what base the light fixture will be installed in, in order to choose the correct gasket, bolts and nuts.

Failure to follow these cautions can result in equipment damage or aircraft FOD. For more information, refer to [INTEROPERABILITY](#) section.



### CAUTION

When a light fixture has been removed from its base, the base must be either fitted with a cover or a spare light fixture put in its place. It is recommended that only authorized personnel disassemble fittings with prior agreement from ADB SAFEGATE.

## 6.1 Safety Instructions



### CAUTION

Electric Shock Hazard

Prior to the commencement of work all electrical services MUST be isolated from the supply and connected to earth. Full details of the work involved must be given to the Authorised Person responsible for the electrical engineering services at the airport with regard to the duration of the work and so on. .. It is recommended that prior to starting any cutting work the nature and location of services such as cable ducts and so on. should be identified Any installation or maintenance work should only be carried out by trained and experienced personnel.



### CAUTION

High Light intensity!

Do not stare directly into the light beam at a close distance.

## 6.2 Safety Considerations

Read the installation section of all system component manuals before starting these steps. A thorough understanding of system components and their requirements will promote safe and efficient installation. See FAA AC 150/5340-30, Design and Installation Details for Airport Visual Aids, and site plans and specifications for field installation of runway and taxiway in-pavement lights.

---



### **DANGER**

Failure to follow these safety procedures can result in personal injury or death.

- Allow only qualified personnel to install ADB SAFEGATE and auxiliary equipment. Use only approved equipment. Using unapproved equipment in an approved system may void FAA approvals. Observe and follow the safety instructions in this document and all other related documentation.
  - Make sure all equipment is rated and approved for the environment where it is being used.
  - Follow all instructions for installing components and accessories.
  - Install all electrical connections in compliance with local and national codes and regulations.
  - Use only electrical wire of sufficient gauge and insulation to handle the rated current demand. All wiring must meet local and national codes.
  - Route electrical wiring along a protected path. Make sure it will not be damaged by moving equipment.
  - Protect components from damage, wear and harsh environmental conditions.
  - Allow ample clearance for maintenance, panel accessibility and cover removal.
  - Protect equipment with safety devices as specified by applicable safety regulations.
  - If safety devices must be removed for installation, reinstall them immediately after the work is completed and check them for proper functioning.
  - The cord set must be protected prior to installation.
- 

## 6.3 Basic Maintenance Program

There are recommended maintenance tasks to ensure that the equipment is in correct operating condition.

Maintenance Tasks	
<b>Weekly</b>	<ul style="list-style-type: none"><li>• Visual inspection of the light fixture.</li><li>• Removal of dust from external surfaces of the light fixture.</li></ul>
<b>Monthly</b>	<ul style="list-style-type: none"><li>• Check of the optical window, check for mechanical damage.</li><li>• Check for proper fixing of the light fixture in its base.</li></ul>
<b>Yearly</b>	<ul style="list-style-type: none"><li>• Detailed inspection of the light fixture.</li><li>• Check of the body resistance, check for mechanical damage (for example cracks around prism windows).</li><li>• Clean of the optical windows.</li></ul>

### **A daily function check is referred to in the document:**

ICAO, Airport Services Manual Part 9, Airport Maintenance Practice and FAA AC 150/5340-26A, Maintenance of airport visual aids facilities.

The light fixture is designed for outdoor operation, however storing the light fixture outside without using it is a risk for damage to light fixture components. For a longer storage time (more than a week), it is recommended to store the light fixture indoors in a dry and dust free environment and at room temperature. Proper storage ensures trouble free replacement procedures. It is strongly recommended not to store any electrical equipment outside.

---

## 6.4 Workshop Maintenance

### Remember

Before you start, make sure you have read and understand [Safety Instructions](#).

### Important

Make sure you check the fixture for watertightness every time you replaced a spare part!

The following standard tools and accessories are required for maintenance of the unit:

- One angled socket spanner of 16 or 17 mm <sup>1</sup>
- One torque limiting spanner with 16 or 17 mm socket <sup>1</sup>
- One hexagonal key (Allen key) of 3, 4, and 5 mm
- Torx screw driver 10, 20, 25, and 30 mm
- Two large flat blade screwdrivers
- Silicone grease
- CC-Patron grease
- One brush or cloth
- Non-alcohol based cleaner



### NOTICE

A compressor, or a manual car tire pump, equipped with a manometer is required to check the light fixture for water-tightness.

Design may differ from picture depending on application. Please follow described work flow and torque level specified as they are generic.

The workshop maintenance refers to following:

1. Replace a light fixture.
2. Check the light fixture for watertightness.
3. Replace a light engine.
4. Replace a prism and its gasket.
5. Replace the bottom cover and converter.
6. Reset the fail-open converter.

### 6.4.1 Disclaimer / Standard Warranty

#### CE certification

The equipment listed as CE certified means that the product complies with the essential requirements concerning safety and hygiene. The European directives that have been taken into consideration in the design are available on written request to ADB SAFEGATE.

#### ETL certification

The equipment listed as ETL certified means that the product complies with the essential requirements concerning safety and C22.2 No.180:13 (R2018) regulations. The CSA directives that have been taken into consideration in the design are available on written request to ADB SAFEGATE.

<sup>1</sup> Depending on type and size of nuts and bolts

## All Products Guarantee

ADB SAFEGATE will correct by repair or replacement per the applicable guarantee below, at its option, equipment or parts which fail because of mechanical, electrical or physical defects, provided that the goods have been properly handled and stored prior to installation, properly installed and properly operated after installation, and provided further that Buyer gives ADB SAFEGATE written notice of such defects after delivery of the goods to Buyer. Refer to the Safety section for more information on Material Handling Precautions and Storage precautions that must be followed.

ADB SAFEGATE reserves the right to examine goods upon which a claim is made. Said goods must be presented in the same condition as when the defect therein was discovered. ADB SAFEGATE further reserves the right to require the return of such goods to establish any claim.

ADB SAFEGATE's obligation under this guarantee is limited to making repair or replacement within a reasonable time after receipt of such written notice and does not include any other costs such as the cost of removal of defective part, installation of repaired product, labor or consequential damages of any kind, the exclusive remedy being to require such new parts to be furnished.

ADB SAFEGATE's liability under no circumstances will exceed the contract price of goods claimed to be defective. Any returns under this guarantee are to be on a transportation charges prepaid basis. For products not manufactured by, but sold by ADB SAFEGATE, warranty is limited to that extended by the original manufacturer. This is ADB SAFEGATE's sole guarantee and warranty with respect to the goods; there are no express warranties or warranties of fitness for any particular purpose or any implied warranties of fitness for any particular purpose or any implied warranties other than those made expressly herein. All such warranties being expressly disclaimed.

## Standard Products Guarantee

Products manufactured by ADB SAFEGATE are guaranteed against mechanical, electrical, and physical defects (excluding lamps) which may occur during proper and normal use for a period of two years from the date of ex-works delivery, and are guaranteed to be merchantable and fit for the ordinary purposes for which such products are made.

---



### Note

See your applicable sales agreement for a complete warranty description.

Replaced or repaired equipment under warranty falls into the warranty of the original delivery. No new warranty period is started for these replaced or repaired products.

---

## FAA Certified products manufactured by ADB SAFEGATE

ADB SAFEGATE L858 Airfield Guidance Signs are warranted against mechanical and physical defects in design or manufacture for a period of 2 years from date of installation, per FAA AC 150/5345-44 (applicable edition).

ADB SAFEGATE LED products (with the exception of obstruction lighting) are warranted against electrical defects in design or manufacture of the LED or LED specific circuitry for a period of 4 years from date of installation, per FAA EB67 (applicable edition). These FAA certified constant current (series) powered LED products must be installed, interfaced and powered with and through products certified under the FAA Airfield Lighting Equipment Program (ALECP) to be included in this 4 (four) year warranty. This includes, but is not limited to, interface with products such as Base Cans, Isolation Transformers, Connectors, Wiring, and Constant Current Regulators.

---



### Note

See your sales order contract for a complete warranty description.

Replaced or repaired equipment under warranty falls into the warranty of the original delivery. No new warranty period is started for these replaced or repaired products.

---

## Liability



### WARNING

Use of the equipment in ways other than described in the catalog leaflet and the manual may result in personal injury, death, or property and equipment damage. Use this equipment only as described in the manual.

---

---

ADB SAFEGATE cannot be held responsible for injuries or damages resulting from non-standard, unintended uses of its equipment. The equipment is designed and intended only for the purpose described in the manual. Uses not described in the manual are considered unintended uses and may result in serious personal injury, death or property damage.

Unintended uses, includes the following actions:

- Making changes to equipment that have not been recommended or described in this manual or using parts that are not genuine ADB SAFEGATE replacement parts or accessories.
- Failing to make sure that auxiliary equipment complies with approval agency requirements, local codes, and all applicable safety standards if not in contradiction with the general rules.
- Using materials or auxiliary equipment that are inappropriate or incompatible with your ADB SAFEGATE equipment.
- Allowing unskilled personnel to perform any task on or with the equipment.

### Copyright Statement

This manual or parts thereof may not be reproduced, stored in a retrieval system, or transmitted, in any form or by any means, electronic, mechanical, photocopying, recording, nor otherwise, without the author's prior written consent.

This manual could contain technical inaccuracies or typographical errors. The author reserves the right to revise this manual from time to time in the contents thereof without obligation of the author to notify any person of such revision or change. Details and values given in this manual are average values and have been compiled with care. They are not binding, however, and the author disclaims any liability for damages or detriments suffered as a result of reliance on the information given herein or the use of products, processes or equipment to which this manual refers. No warranty is made that the use of the information or of the products, processes or equipment to which this manual refers will not infringe any third party's patents or rights. The information given does not release the buyer from making their own experiments and tests.

## 6.4.2 Exploded View

Figure 4: Omnidirectional Light, 4 prisms, 8-inch

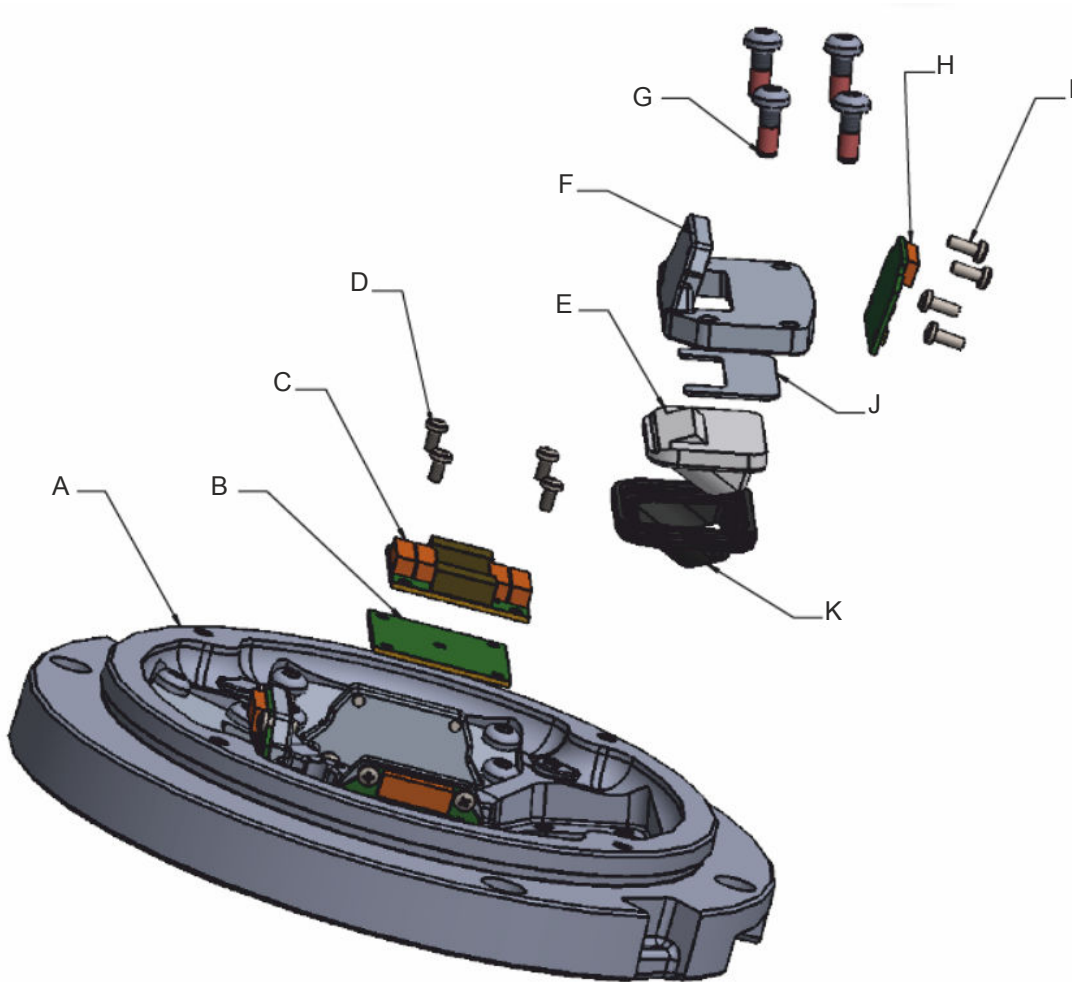

Table 1: Legend Exploded View

Call-out number	Description	Quantity
A	Top cover	1 pc
B	Isolation board	1 pc
C	Connection board	1 pc
D	Screw M3x8 DIN7985-T-A2	4 pcs
E	Prism	4 pcs
F	Holder prism	4 pcs
G	Screw M4 x6	16 pcs
H	LED board	4 pcs
I	Screw M3x8 DIN7985-T-A2	4 pcs
J	Protection prism plate	16 pcs
K	Gasket	4 pc



### 6.4.3 Opening a 8-inch Fixture

#### Removal

1. Place the light fixture upside down and remove the four screws for the bottom cover using an Allen key 4 mm, see [Figure 5](#).
2. Lift up the housing and disconnect the LED board cable connector from the LED boards in the top cover, see [Figure 6](#)



#### NOTICE

Open the light fixture carefully so that you do not damage the LED-board cables.

3. Remove the bottom cover from the top cover.
4. Remove the O-ring gasket from the bottom cover, see [Figure 7](#).

**Figure 5: Fixture upside down**

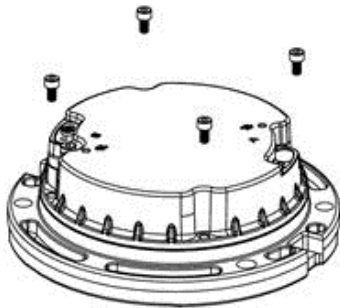

**Figure 6: Lifting up housing**

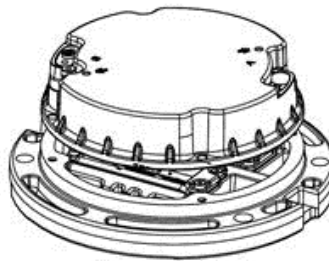

**Figure 7: Removing gasket**

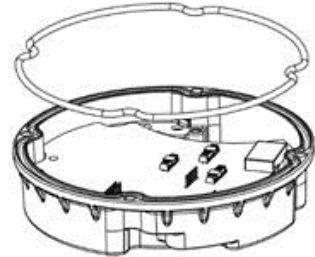

### 6.4.4 Closing a 8-inch Fixture

#### Replacement

1. Carefully clean all contact surfaces of the light fixture and of the housing.
2. Install a new inner pan gasket on the bottom cover.

#### Important

The inner pan gasket must be changed each time the light fixture is disassembled.

3. Connect the LED board cable connector(s) to the supply terminal(s) of the converter in the housing, see [Figure 8](#).



### NOTICE

Note the orientation and alignment of the LED board cables, which are different between 1 connector and 2 connector versions.

Converters with one connector: The cables should have colored wires towards each other and crossed.

Converters with two connectors: The cables should have colored wires away from each other and crossed. Light fixtures with only one LED-board need to have its LED-board connected to the LED B channel.

**Figure 8: Converter with 1 connector**

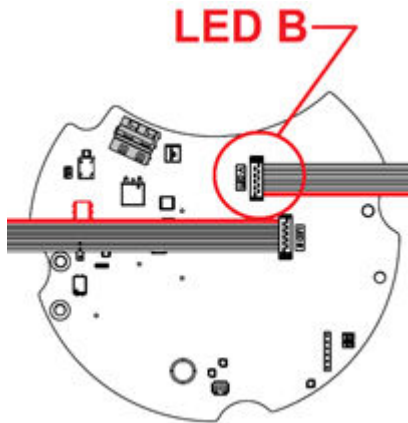

**Figure 9: Converter with 2 connectors**

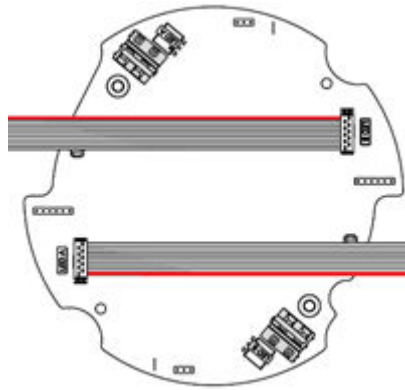

4. Place the top cover over the bottom cover, align A and B sides on the top cover with the corresponding sides on the bottom cover.

### Important

Before closing the light fixture, it is important to make sure the inner pan gasket is placed correctly in the groove of the bottom cover to prepare the light fixture for water tightness checks and use in the airfield.

5. Put the light fixture on a surface with the top cover facing down, see [Figure 10](#).

**Figure 10: Fixture facing down**

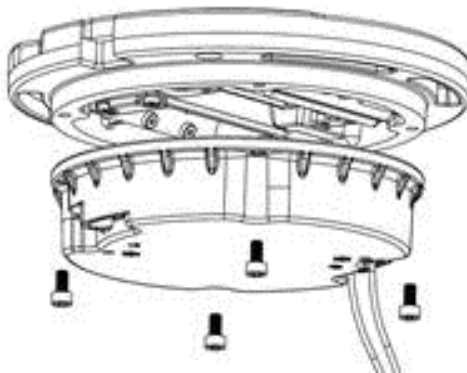

6. Tighten the four screws using a torque limiting spanner 4 mm Allen key to a torque of 8 Nm (equivalent to 0.8 kg m or 8 g.cm). See [Figure 11](#).

**Figure 11: Tightening screws**

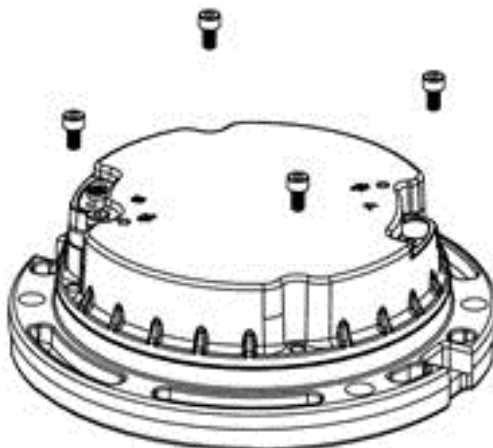

7. Check the light fixture for water-tightness.



**Note**

Refer to [Checking the Light Fixture for Watertightness](#) section for more information.

#### 6.4.5 Checking the Light Fixture for Watertightness



**NOTICE**

If maintenance is carried out in a workshop, check the watertightness of the light.

**Preparation**

1. Remove the water-tightness test valve cap.
2. Fill up the light fixture with compressed air (test pressure = 130 kPa).

**Test**

1. Put the light fixture in water, wait 3 minutes and check if air leaks out of the light.
  - a. If air leaks out of the light fixture (between bottom cover and top plate or between prism and top plate or water-tightness valve and top plate), the light fixture is not watertight and must be repaired. Release the air from the light. Disassemble the light fixture and re-check the mating surfaces and gaskets. Assemble the light fixture and perform the water-tightness test again.
  - b. If the light fixture is watertight, release the compressed air from the light fixture and assemble the cap on the test valve.
2. The light fixture is ready to be reinstalled in the field.



**WARNING**

Never exceed pressure of 150 kPa inside the light fixture as this may lead to personal injuries and damage the light.

## 6.4.6 Replacing a Light Engine in a 8-inch Fixture

### Removal

**Important**

Make sure that you replace all 4 LEDs (LED boards) in case you have to replace one defective LED.

1. Open the light and disconnect it from the bottom pan.
2. Remove the bracket and replace LED board (similar to top cover assembly).

The Light engine consists of parts a), b), c) and d), see [Figure 12](#).

**Figure 12: Light engine replacement**

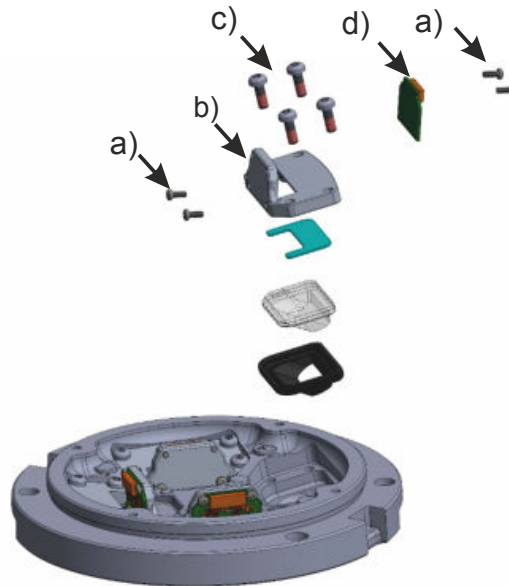

1. Disassemble the light fixture.
2. Detach and remove the LED board holder, including 4 screws from the body, using a 3 mm Allen key. See [Figure 13](#).

**Figure 13: Removing the LED board holder**

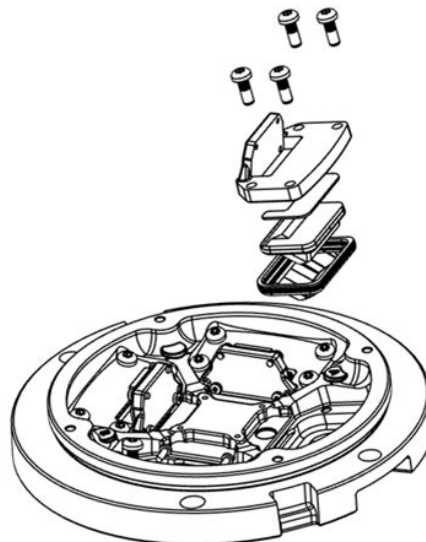

## Replacement

1. Attach the new LED board holder, including screws. The screws on the LED holder shall be tightened gently in sequence, following figure call-outs 1-4. See [Figure 14](#)
2. Tighten the same screws to a torque of 4.5 Nm, following figure call-outs 5-9. See [Figure 14](#).

**Figure 14: Tightening screws**

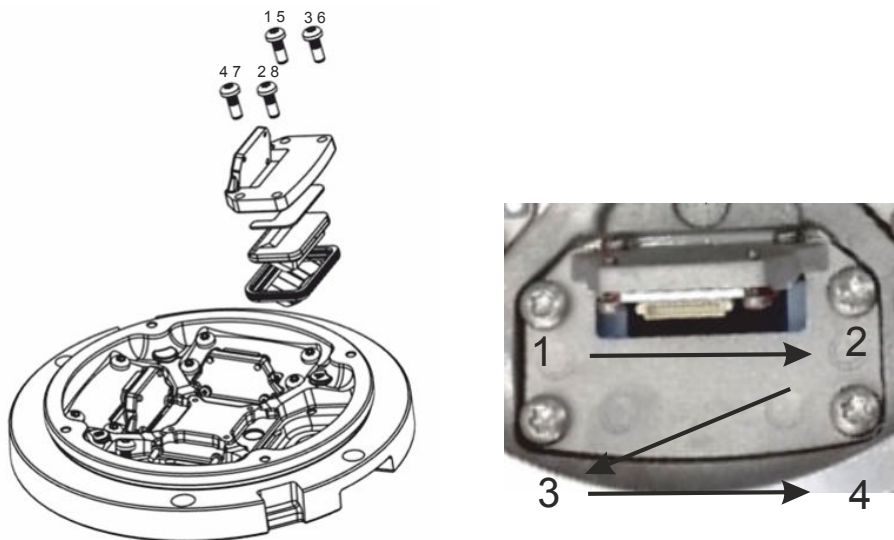

3. Connect the LED-cable(s) to the LED-board(s) and note the cable orientation in [Figure 15](#).

**Figure 15: LED board**

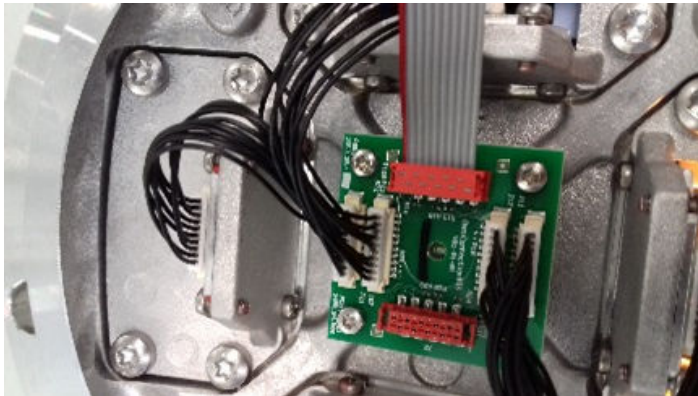

4. Assemble the light fixture.

### 6.4.7 Replacing the Top Cover

**i NOTICE**  
Top covers are delivered without the LED boards. LED boards have to be ordered separately.

**i Note**  
When a top cover is replaced, new LED boards (which are mounted on the brackets) have to be mounted. For LED board replacement new gaskets and blue spacers are required. They are available separately.

1. Open the light by disconnecting the top cover from the bottom cover.

**Figure 16: Top cover with bottom cover**

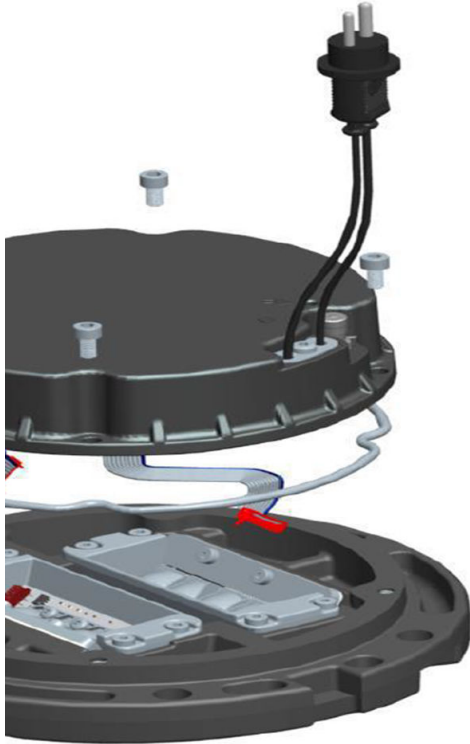

2. Remove the cables from the assembly.
3. Disconnect the inner pan gasket, the prism gasket, the prism protection plate (blue spacer), the prism and the LED kit from the cover. The gaskets and the prisms have to be replaced after delivery.  
You have to remove the prism holder (bracket) to mount the LED board.



**Note**

Follow the instruction on mounting a LED board in the [Replacing the LED Board](#) section.

4. Place the components on the bottom cover.
5. Reconnect the parts and the cables.
6. Place the bottom cover on the top cover with component and connect them with the screws and connectors.
7. Close the fixture.

### 6.4.8 Replacing the Connection Board

The connection board number b) is included in the converter board assembly kit. The connection board is assembled with the isolation board (split board) number a) on the top cover. This combination is fixed together with 4 screws (call-out c)).

**Figure 17: Replacing the connection board**

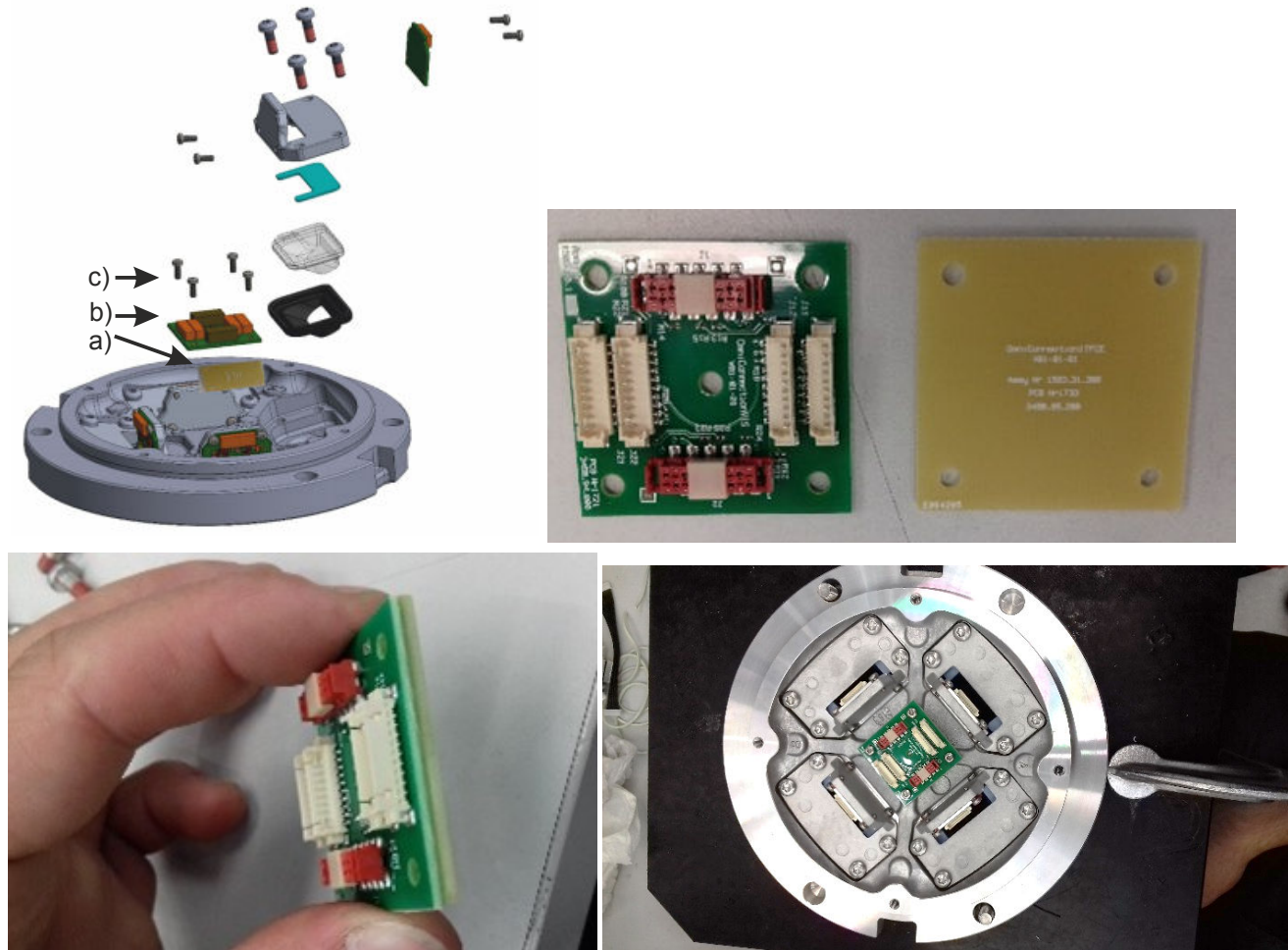

1. Disconnect the red connectors from the connection board.
2. Loosen the cables.
3. Remove the old connection board with the isolation board from the top cover.
4. Insert the new connection board with the isolation board on the top cover.
5. Connect the cables to the connection board.
6. Connect the connection board with the isolation board on the top cover.



#### Note

There are two different types of connectors (entry cables) that are led from the converter to the LED board (and not to the LED modules). The black one (4 pieces of 70 mm each) connect the connection board with the LED boards and the red connectors (2 pieces of 180 mm each) connect the connection board with the converter. The cables are available separately in a cable kit.



Figure 18: Two connector types (replaceable)



Figure 19: Red and black cable connections

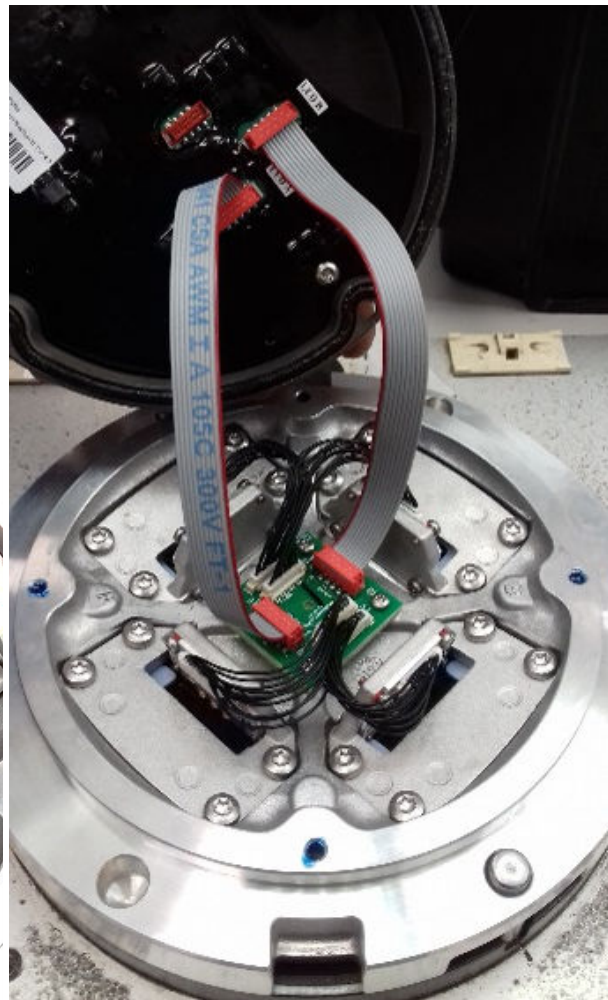
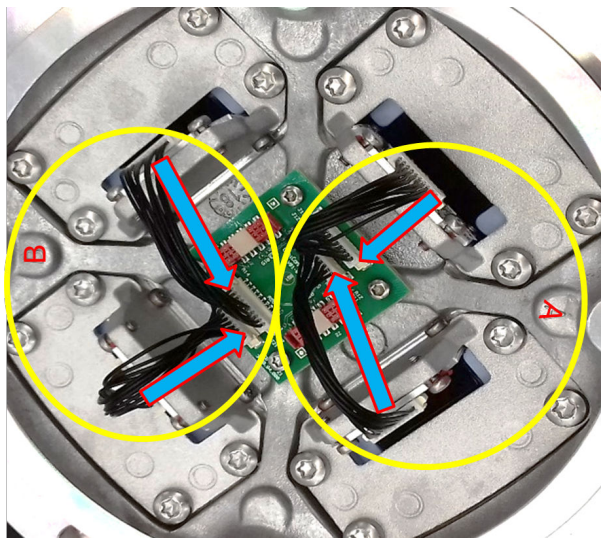

7. Close the fixture.

### 6.4.9 Replacing the LED Board

The LED board is included in the LED kit. LED boards are delivered mounted on the LED prism holders (brackets). You can mount the LED board without disassembling the connection board.

#### **i** NOTICE

Replace blue spacer and prism gasket to mount the LED board when a new fixture is delivered. The spacers and gasket that are mounted upon receipt are only mounted as a transportation protection. Make sure you throw them away!

1. Remove the brackets from the prisms being in place when they are delivered to mount the LED board.



#### Note

Refer to [Figure 20](#) figure.

**Figure 20: LED sub assembly (Optical assembly)**

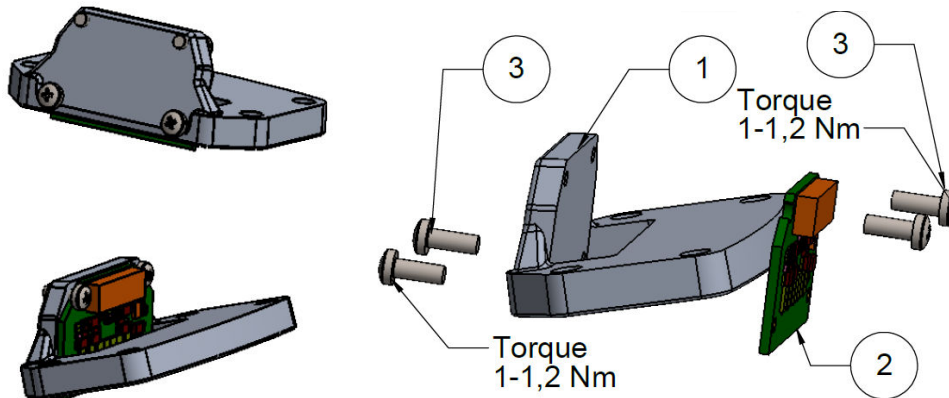

2. Put the new LED board (number 2) onto the assembly with cables.
3. Connect the cables with the LED board.
4. Set the LED optical assembly with the prism protection plate and the prism on the gasket (prism assembly kit).
5. Put the prism assembly onto the top cover.
6. Close the fixture.

### 6.4.10 Replacing a Prism, Gaskets and Blue Spacers (Prism Protection Plates) in a 8-inch Fixture

#### Removal

#### Important

Make sure that you replace all 4 prisms in case you replace a prism. It is required to replace them when there is water in the fixture or when the prism is cracked!



#### NOTICE

Preventive maintenance info: Make sure that you replace all 4 prisms when one LED is defective.

1. Disassemble the light fixture:
  - a. Disassemble the prism holder (bracket) from the top cover.



**NOTICE**

Every time the prism holders are replaced, the prism protection plates (blue spacers) require replacement, too.

b. Remove bracket number d) and replace parts a), b) and c), see [Figure 21](#).

**Restriction**

As soon as part d) is replaced, part a) and c) must be replaced, too. If this action is not executed, the fixture will not be watertight any more!

**Figure 21: Exploded view - prism replacement**

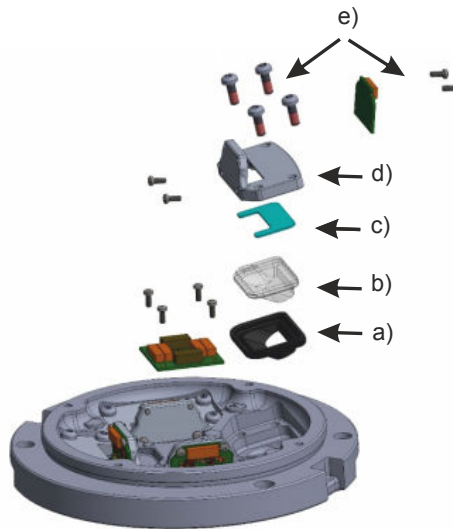

2. Detach and remove the LED board holder, including 4 screws from the body, using a 3 mm Allen key. See [Figure 22](#).

**Figure 22: Remove LED board holder**

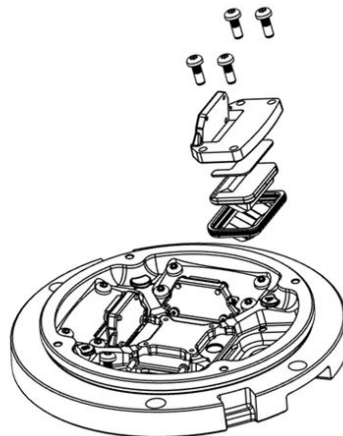

**Remember**

Never reuse the screws! The screws number e) are included in the kit (not as spare parts).

3. Remove the Teflon and steel protective plates from the LED board holder.
4. Remove the prism and its gasket, see [Figure 23](#).

**Figure 23: Remove prism and gasket**

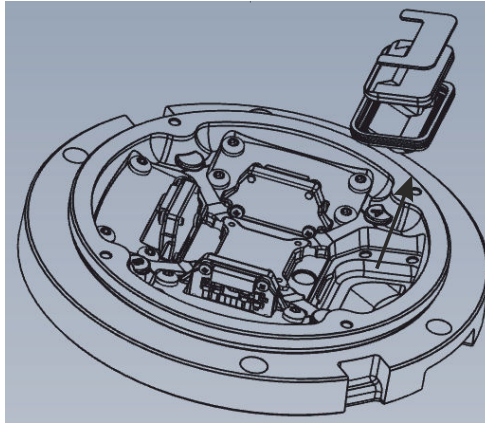

---

## Replacement



### NOTICE

The prism gaskets and the protection prism plate require replacement every time a prism is replaced. That means that when 4 prisms have to be replaced, 4 gaskets and prism protection plates require replacement, too.

---

1. Lubricate the new prism gasket with CC Patron grease.
2. Place the prism gasket in the prism opening in the top cover.
3. Put the new prism into the new prism gasket, then push it all the way into the opening and hold for about a minute. See [Figure 24](#).

**Figure 24: New prism into prism gasket**

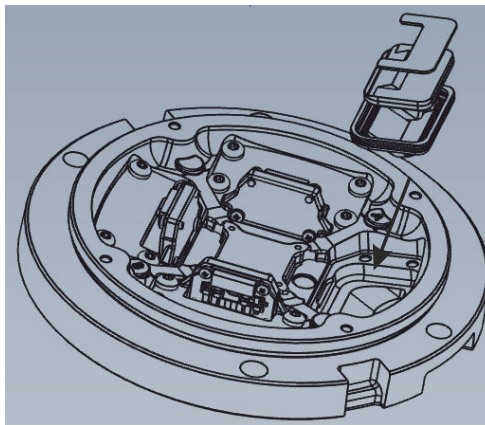

4. Make sure that the O-ring of the prism gasket is even in the chambered area.
5. Place the new Teflon protective plate and steel plate over the prism and prism gasket and tighten the two M4 screws to a torque of 4.5 Nm.

6. Looking from above, make sure the prism edge is parallel with the prism holder, see [Figure 25](#).

**Figure 25: Prism holder edge**

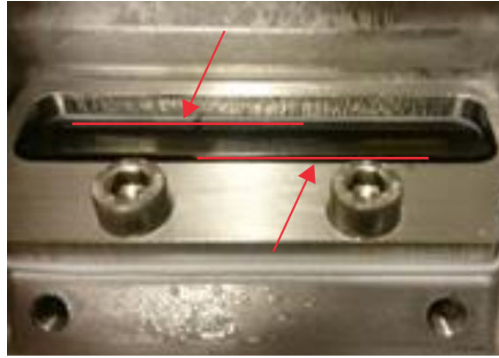

7. Use alcohol based cleaner to remove any grease or dust from the prism.

8. Attach the LED board holder, including screws. The screws on the LED holder shall be tightened to a torque of 4.5 Nm, in sequence 1-4. Tighten the same screws again to a torque of 4.5 Nm, in sequence 5-8. See [Figure 26](#).



**Note**

The torquing sequence must be respected as it ensures correct positioning of the prism.

**Figure 26: Tighten screws in sequence**

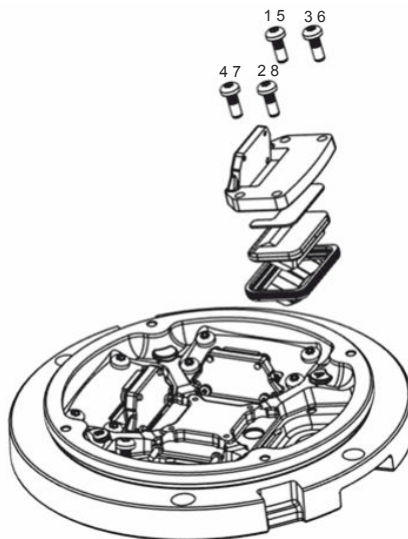

9. Re-tighten the two screws on the steel plate to 4.5 Nm. See [Figure 26](#).

10. Assemble the light fixture.

Make sure the gasket is fitted in correctly, see [Figure 27](#).

**Figure 27: Correct gasket position**



11. Cut off any protruding prism gasket on the outside of the top cover.



**Note**

Make sure you check the fixture for watertightness every time you have to replace a spare part!

---

### 6.4.11 Replacing the Bottom Cover and Converter

#### Removal

1. Disassemble the light fixture.
2. From inside the housing, disconnect all cables from the LED board.

#### Replacement

1. Place the new gasket on the new bottom cover with the converter.
2. Connect the LED board cable(s). Note the orientation and alignment of the cables in [Figure 28](#) and [Figure 29](#) figures.



**NOTICE**

Make sure that light fixtures with only one LED-cable is connected to the LED B-channel.

**Figure 28: Converter with 1 connector**

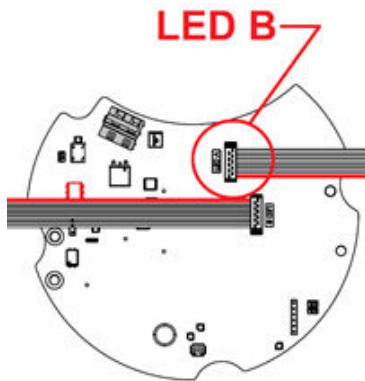

**Figure 29: Converter with 2 connectors**

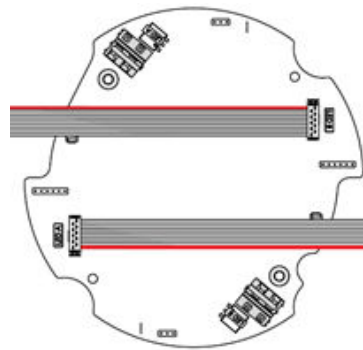

3. Assemble the light fixture.

**6.4.12 Resetting the Fail-open converter 2.3**

**Opening procedure**

1. Disconnect and disassemble the light fixture.
2. Make sure you have a 2-way electrical shunt/jumper (2.54 mm / 0.100-inch spacing), see [Figure 30](#).

**Figure 30: 2-way electrical shunt / jumper**



**Resetting procedure**

1. Locate the 3-pin reset connector(s) on the converter. For the two-connector converter, there is one reset connector for each side.
2. Place the 2-way electrical shunt (2.54 mm spacing) over the **two pins** marked red. See [Figure 31](#) and [Figure 32](#).

**Figure 31: Converter with 1 connector**

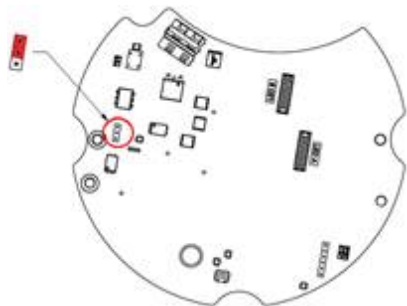

**Figure 32: Converter with 2 connectors**

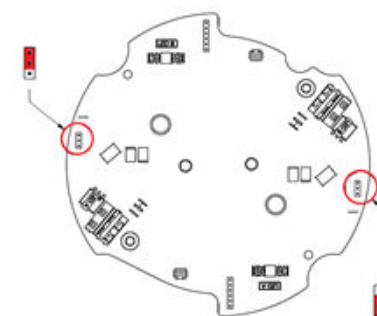

3. Close the light fixture and connect it to a CCR.



4. Energize the light fixture until there is a steady light, then turn the CCR off and unplug the light fixture.
5. Disassemble the light fixture, then remove the two-way electrical shunt (2.54 mm spacing) from the pins.
6. Assemble the light fixture and perform a functional test.

### 6.4.13 Resetting the Fail-open converters 48010921 and 48011111

#### Parts

- Fuse resistor spare part kit: 6132.00.250 (20pcs)

#### Info

- Converter with 1 connector have 2 fuse resistors
- Converter with 2 connectors have 4 fuse resistors

#### Resetting / replacing the fuse resistors

1. Disconnect and disassemble the light fixture.
2. Locate the fuse resistors, see [Figure 33](#) and [Figure 34](#).

---

**Figure 33: Converter with 1 connector**

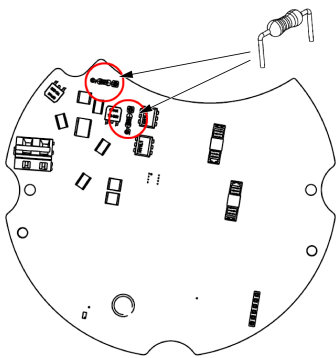

**Figure 34: Converter with 2 connectors**

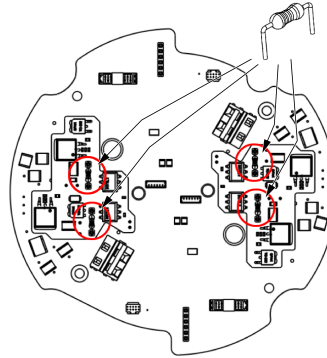

3. Remove the fuse resistors by pulling away from the converter.
  - a. For converters with 1 connector, always replace both fuse resistors at the same time.
  - b. For converters with 2 connectors, always replace both fuse resistors related to the A/B channel that needs to be reset. If both A and B channel needs a reset, replace all 4 fuse resistors.
4. Dispose the old fuse resistor.
5. Place the legs of the new fuse resistors in the sockets.
6. Assemble the light fixture and perform a functional test.



## 7.0 Spare Parts

Spare parts are available for RELIANCE and RELIANCE IQ inset light fixtures. For more information, see [www.adbsafegate.com](http://www.adbsafegate.com) and the spare part lists, or contact ADB SAFEGATE for assistance.

### 7.1 Ordering Code Apron Maneuvering

#### Ordering Code

R S A M

#### Standard

3 = ICAO

#### Market-Specific

0 = None

#### Dimensions

1 = 8 inch

#### Prism

P = 4 protected prisms

#### Beam Orientation

3 = Omnidirectional

#### Toe-in

N = Not applicable

#### Colors (Side 1)

R = Red

Y = Yellow

#### Colors (Side 2)

N = Not applicable

#### Power and Monitoring

S = 2.8 - 6.6 A, non-Monitored - power only

M = 2.8 - 6.6 A, Fail-Open monitoring

P = 2.8 - 6.6 A / 2A, IQ0 integrated (IQ disabled)

Q = 2.8 - 6.6 A / 2A, IQ1 integrated (IQ enabled)

#### Connector and Cable

1 = 1 x Style 6 2-pin plug, 2 individual wires

5 = 1 x flat 3-pin plug, 3 individual wires<sup>1</sup>

#### Options

0 = None

#### Version

1 = First version

#### Notes

<sup>1</sup> French 3-pin plug (1F)

## 7.2 Ordering Code Taxiway Edge

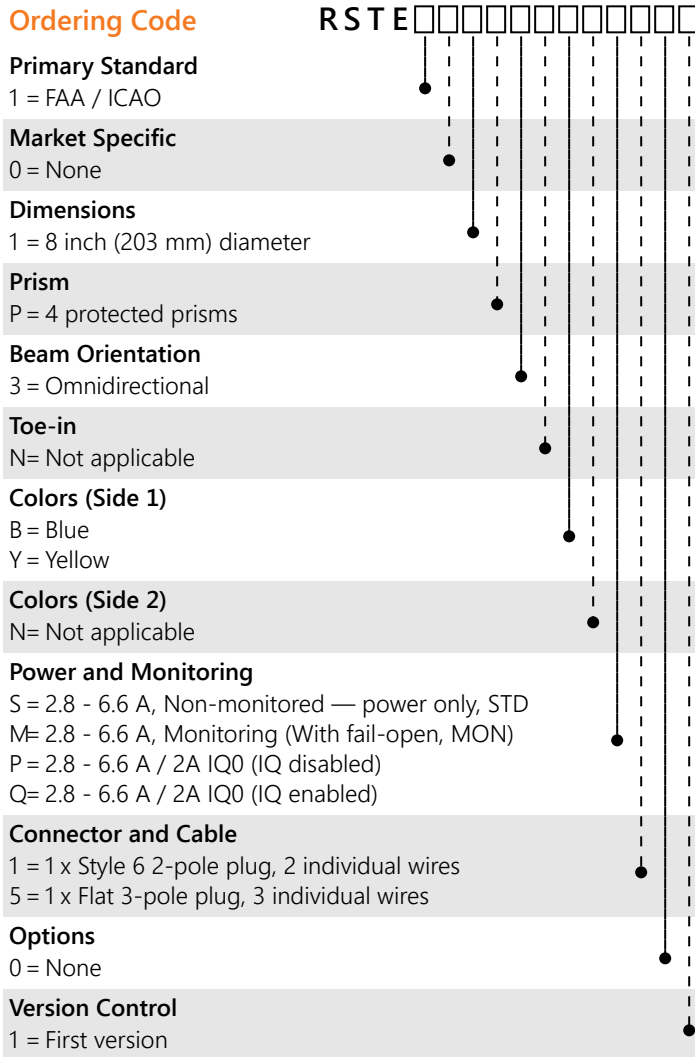

## 7.3 Components

	Components	Versions	Article number	Packing <sup>1</sup>
A	OMNI 4P	Full inner pan assembly for Non-MON lights	SP013105	Per 1
		Full Inner Pan assembly for IQ lights	SP017117B	Per 1
		Full Inner Pan assembly for FO lights	SP018059B	Per 1
		Full top cover (including prisms, gaskets, screws, connection board but without LED engine kit, without converter cables)	SP013043	Per 1
B	OMNI 4P prism kit	Prism kit (including prism gasket & blue spacer & set of screws for support)	SP013031	Per 4
C	OMNI 4P LED kit	LED strip bracket assembly - blue - TWY edge (including 4 assemblies with screws and LED cables)	SP013044	Per 4
		LED strip bracket assembly - blue with NIR - TWY edge (including 4 assemblies with screws and with LED cables)	SP013045	Per 4
		LED strip bracket assembly - red - APRON (including 4 assemblies with screws and with LED cables)	SP013046	Per 4
		LED strip bracket assembly - yellow - APRON (including 4 assemblies with screws and with LED cables)	SP013047	Per 4
		LED strip bracket assembly - yellow - INTERMEDIATE HOLDING POINT (including 4 assemblies with screws and with LED cables)	SP013048	Per 4
		LED strip bracket assembly - yellow with NIR - INTERMEDIATE HOLDING POINT (including 4 assemblies with screws and with LED cables)	SP013049	Per 4
D	OMNI 4P LED cables 4P	Set of LED cables	SP6100.50.200	Per 20
E	OMNI 4P Connection Board Kit	Connection board kit	SP013032	Per 1
F	OMNI 4P Connection Converter cables	Set of Connection Converter cables	SPSGE48000269D1	Per 10
G	OMNI 4P Bottom cover gasket	Set of bottom cover gaskets	SPMS00005-000-01	Per 10
H	OMNI 4P prism gaskets	Set of prism gaskets (no prisms)	SP4072.78.030	Per 20
I	OMNI 4P blue spacers	Set of blue prism spacers (no prisms)	SP4072.78.040	Per 20

### Notes

<sup>1</sup> Example: If you order 1× article number SP6100.50.200, you will receive 20 cables.

## 7.4 Screws Overview

Screw type	Name	Quantity on a fixture	Torque (Nm)
M3x8 DIN7985-T-A2	LED optical (sub) assembly screws	16	1-1.2 Nm + Loctite 2045
M3x6	Pan head cross recess screw	4	
M5x14		16	8 Nm
M6x1	Inner pan lock nut (mounted by manufacturer)		1.5 Nm + Loctite 577

RELIANCE Omni Protected 8-inch  
Spare Parts

Screw type	Name	Quantity on a fixture	Torque (Nm)
M4x12	PCB screw for inner pan (mounted by manufacturer)		1.5 Nm - no Loctite
M4x6	Ground fixation screw for inner pan (mounted by manufacturer)		1.5 Nm - no Loctite
M4x10	Cable disc screw		2.5 Nm - no Loctite

## Appendix A: INTEROPERABILITY

### Base installation – O-ring selection and retaining bolts for 12-inch



#### CAUTION

Use of incorrect combination of gaskets, bolts and nuts can create severe damages to the product installation and create multiple safety risks.

To obtain a safe and watertight installation the O-ring and retaining bolt stated in the document must be used.

You need to know what base the light fixture will be installed in, in order to choose the correct gasket, bolts and nuts.

**Failure to follow these cautions can result in equipment damage or aircraft FOD.**

**Table 2: Interoperability matrix**

Base type	Required O-ring	Bolt installation		Stud installation	
		Required dimension	Recommended torque	Required nut	Recommended torque
ADB 8 in Eurobase	Blue O-ring SGE.SP24521/10 pc SGE.SP24524/100 pc	1411.20.522, metric screw kit 8 in M10×25 mm	21 Nm + Loctite 2701 or 638	1411.20.430, self-locking nut kit M10 H100	21 Nm <sup>1</sup>
ADB 8 in Eurobase CN (150 mm)					
Adapter ring ADB 8 in–12 in					
ADB 8 in HPI	Grey O-ring SGE.SP24522/10 pc SGE.SP24525/100 pc	1411.20.522, metric screw kit 8 in M10×25 mm	21 Nm + Loctite 2701 or 638	1411.20.430, self-locking nut kit M10 H100	21 Nm <sup>1</sup>
Safegate 8 in (135 mm)	Red O-ring SGE.SP24523/10 pc SGE.SP24526/100 pc	1411.20.522, metric screw kit 8 in M10×25 mm	40 Nm + locking washer, max height 2 mm	1411.20.430, self-locking nut kit 8 in M10 H100	35 Nm
RELIANCE BASE 8 in (135 mm)					
Thorn 8 in (100 mm)					
Thorn 8 in (133 mm)					
Thorn 8 in MK2 (133 mm)					
IDM 6494 (120 mm)					
Adapter ring SG/Thorn/ID 8 in–12 in					
ERNI 8 in EE08 (150 mm)	Blue O-ring SGE.SP24521/10 pc SGE.SP24524/100 pc	1411.20.522, metric screw kit 8 in M10×25 mm	40 Nm + locking washer, max height 2 mm	1411.20.430, self-locking nut kit 8 in M10 H100	35 Nm
ERNI 8 in ED08 (133 mm)					

#### Notes

<sup>1</sup> Do not use Loctite or washer with self-locking nut.



## Appendix B: POWER TABLE

Fixture type	Fixture load	Isolation transformer			CCR load
		Rating	Loss	Efficiency	
RS -TE (omnidirectional, inset)	14 VA	25 / 35 W	4 VA	0.85	20 VA



### Note

- Extra losses in secondary cables or due to extra equipment (e.g. ILCMS remotes) are not included in above table; these extra losses will result in a higher required size of isolation transformers.
- Extra losses in primary cables are not included in above table; these extra losses will result in a higher required CCR load.
- Efficiency of the secondary transformer depends on the supplier of secondary transformers.





## Appendix C: CABLE LOSS

The cable resistance R (ohms) for 1 conductor is calculated with following formula:

- $R \text{ (ohms)} = \text{resistivity of material (ohm m)} \times \text{length (m)} / \text{cross sectional area (m}^2\text{)}$
- For copper conductors the resistivity is  $1.72 \cdot 10^{-8} \text{ (m}^2\text{)}$

Example; for 1 km  $2.5 \text{ mm}^2$  copper conductor, the resistance R is calculated as follows:

$$1.72 \cdot 10^{-8} \times 1000 / 2.5 \cdot 10^{-6} \text{ m}^2 = 6.88 \text{ ohms}$$

The loss (Watt) is then  $R \times I^2$  or  $6.88 \text{ ohms} \times 6.6^2 \text{ A}^2 = 299.69 \text{ W/km}$  or  $0.299 \text{ W/m}$ .

The loss (Watt) for a secondary cable with 2 conductors is thus  $2 \times 0.299 = 0.599$  or  $0.6 \text{ W/m}$ .

As such we can calculate:

- Secondary cable for a  $2.5 \text{ mm}^2$  Cu-wire (2 conductors):  $0.6 \text{ W/m}$
- Secondary cable for a  $4 \text{ mm}^2$  Cu-wire (2 conductors):  $0.4 \text{ W/m}$
- Primary cable for a  $6 \text{ mm}^2$  Cu-wire (1 conductor):  $0.12 \text{ W/m}$

The cable between the isolation transformer and the lamp adds losses that cannot be ignored when dimensioning the circuits and selecting rating for secondary transformers and regulators.



### WARNING

Cable lengths should not exceed 100 meters.

For a secondary cable of e.g., 20 m of  $2.5 \text{ mm}^2$  CU-wire,  $20 \text{ m} \times 0.6 \text{ W/m} = 12 \text{ W}$  equals the additional loss to be taken into account.

For a primary cable of e.g., 100 m of  $6 \text{ mm}^2$  CU-wire,  $100 \text{ m} \times 0.12 \text{ W/m} = 12 \text{ W}$  equals the additional loss to be taken into account.



## Appendix D: SUPPORT

Our experienced engineers are available for support and service at all times, 24 hour/7 days a week. They are part of a dynamic organization making sure the entire ADB SAFEGATE is committed to minimal disturbance for airport operations.

### ADB SAFEGATE Support

#### Live Technical Support – Americas

If at any time you have a question or concern about your product, just contact ADB SAFEGATE's technical service department. Trained in all areas of system issues, troubleshooting, quality control and technical assistance, our highly experienced Technical support specialists are available 24 hours a day, seven days a week to provide assistance over the phone.

**ADB SAFEGATE Americas Technical Service & Support (US & Canada): +1-800-545-4157**

**ADB SAFEGATE Americas Technical Service & Support (International): +1-614-861-1304**

During regular business hours, you can also Chat with a Service Technician. We look forward to working with you!

#### Before You Call

When you have an airfield lighting or system control system problem, it is our goal to support airfield maintenance staff as quickly as possible. To support this effort, prior to calling, please ensure the following:

- Review the product's manual and troubleshooting guide.
- Be located with the product ready to troubleshoot.
- Have all necessary information available: airport code/company name, customer id number, contact phone number/email address, product/part number.
- Have a *True RMS* meter available and any other necessary tools.

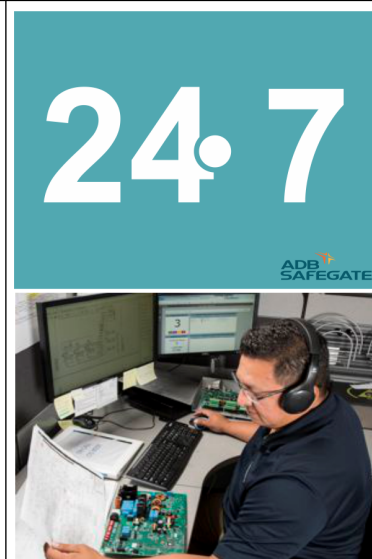

#### Note

For more information, see [www.adbsafegate.com](http://www.adbsafegate.com), or contact ADB SAFEGATE Support via email at [support@adbsafegate.com](mailto:support@adbsafegate.com) or

Europe: +32 2 722 17 11

Americas: +1 614 861 1304. Press 3 for technical service or press 4 for sales support.

China: +86 (10) 8476 0106

Middle East and Africa: +971 4 452 7575

## D.1 ADB SAFEGATE Website

The ADB SAFEGATE website, [www.adbsafegate.com](http://www.adbsafegate.com), offers information regarding our airport solutions, products, company, news, links, downloads, references, contacts and more.

## D.2 Recycling

### D.2.1 Local Authority Recycling

The disposal of ADB SAFEGATE products is to be made at an applicable collection point for the recycling of electrical and electronic equipment. The correct disposal of equipment prevents any potential negative consequences for the environment and human health, which could otherwise be caused by inappropriate waste handling. The recycling of materials helps to conserve natural resources. For more detailed information about recycling of products, contact your local authority city office.

### D.2.2 ADB SAFEGATE Recycling

ADB SAFEGATE is fully committed to environmentally-conscious manufacturing with strict monitoring of our own processes as well as supplier components and sub-contractor operations. ADB SAFEGATE offers a recycling program for our products to all customers worldwide, whether or not the products were sold within the EU.

ADB SAFEGATE products and/or specific electrical and electronic component parts which are fully removed/separated from any customer equipment and returned will be accepted for our recycling program.

All items returned must be clearly labeled as follows:

- For *ROHS/WEEE* Recycling
- Sender contact information (Name, Business Address, Phone number).
- Main Unit Serial Number.

ADB SAFEGATE will continue to monitor and update according for any future requirements for *EU directives* as and when *EU member states* implement new *regulations* and or *amendments*. It is our aim to maintain our *compliance plan* and assist our customers.

## Company Addresses

ADB SAFEGATE, Belgium	ADB SAFEGATE BV Leuvensesteenweg 585, B-1930 Zaventem Belgium
Contact: Tel.: +32 2 722 17 11 Fax: +32 2 722 17 64	Email: <a href="mailto:marketing@adbsafegate.com">marketing@adbsafegate.com</a> Internet: <a href="http://www.adbsafegate.com">www.adbsafegate.com</a>
ADB SAFEGATE, Americas	ADB SAFEGATE Americas LLC 700 science Blvd, Colombus OH 43230, USA
Contact: Tel.: +1 (614) 861 1304 Fax: +1 (614) 864 2069	Email: <a href="mailto:sales.us@adbsafegate.com">sales.us@adbsafegate.com</a> Internet: <a href="http://www.adbsafegate.com">www.adbsafegate.com</a>
ADB SAFEGATE, Sweden	ADB SAFEGATE Sweden AB Djurhagegatan 19 SE-213 76 Malmö Sweden
Contact: Tel.: +46 (0)40 699 17 00 Fax: +46 (0)40 699 17 30	Email: <a href="mailto:marketing@adbsafegate.com">marketing@adbsafegate.com</a> Internet: <a href="http://www.adbsafegate.com">www.adbsafegate.com</a>
ADB SAFEGATE, China	ADB SAFEGATE Airfield Technologies Ltd. China Unit 603, D Block, CAMIC International Convention Center, No 3, Hua Jia Di East road, ChaoYang district, Beijing 100102 P.R. China
Contact: Tel.: +86 (10) 8476 0106 Fax: +86 (10) 8476 0090	Email: <a href="mailto:china@safegate.com">china@safegate.com</a> Internet: <a href="http://www.adbsafegate.com">www.adbsafegate.com</a>
ADB SAFEGATE, Germany	ADB SAFEGATE Germany GmbH Konrad-Zuse-Ring 6, D-68163 Mannheim Germany
Contact: Tel.: +49 (621) 87 55 76-0 Fax: +49 (621) 87 55 76-55	Email: <a href="mailto:marketing@adbsafegate.com">marketing@adbsafegate.com</a> Internet: <a href="http://www.adbsafegate.com">www.adbsafegate.com</a>



## Powering Your Airport Performance from Approach to Departure

[adbsafegate.com](https://adbsafegate.com)

Copyright © ADB SAFEGATE, all rights reserved

