



Airfield Lighting Series Cutout  
ALSC

## User Manual

96A0490, Rev. C, 2018/10/29

  
**ADB  
SAFEGATE**



## A.0 Disclaimer / Standard Warranty

### CE certification

The equipment listed as CE certified means that the product complies with the essential requirements concerning safety and hygiene. The directives that have been taken into consideration in the design are available on written request to ADB SAFEGATE.

### ETL certification

The equipment listed as ETL certified means that the product complies with the essential requirements concerning safety and FAA Airfield regulations. The directives that have been taken into consideration in the design are available on written request to ADB SAFEGATE.

### LED Product Guarantee

Where applicable, per FAA EB67 (applicable edition), ADB SAFEGATE L858(L) Airfield Guidance Signs are warranted against electrical defects in design or manufacture of the LED or LED specific circuitry for a period of 4 years. ADB SAFEGATE LED light fixtures (with the exception of obstruction lighting) are warranted against mechanical and physical defects in design or manufacture for a period of 12 months from date of installation; and are warranted against electrical defects in design or manufacture of the LED or LED specific circuitry for a period of 4 years per FAA EB67 (applicable edition).



#### Note

See your sales order contract for a complete warranty description. In some specific cases, deviations are (to be) accepted in the contract, which will supersede the standard warranty.

### Standard Product Guarantee

Products of ADB SAFEGATE manufacture are guaranteed against mechanical, electrical, and physical defects (excluding lamps) which may occur during proper and normal use for a period of one year from the date of installation or 2 years from date of shipment and are guaranteed to be merchantable and fit for the ordinary purposes for which such products are made. ADB SAFEGATE L858 Airfield Guidance Signs are warranted against mechanical and physical defects in design or manufacture for a period of 2 years from date of installation per FAA AC 150/5345-44 (applicable edition).



#### Note

See your sales order contract for a complete warranty description.

### All Products Guarantee

LED Products of ADB SAFEGATE, manufactured and sold by ADB SAFEGATE or its licensed representatives, meets the corresponding requirements of FAA, ICAO and IEC.

ADB SAFEGATE will correct by repair or replacement per the applicable guarantee above, at its option, equipment or parts which fail because of mechanical, electrical or physical defects, provided that the goods have been properly handled and stored prior to installation, properly installed and properly operated after installation, and provided further that Buyer gives ADB SAFEGATE written notice of such defects after delivery of the goods to Buyer. Refer to the Safety section for more information on Material Handling Precautions and Storage precautions that must be followed.

ADB SAFEGATE reserves the right to examine goods upon which a claim is made. Said goods must be presented in the same condition as when the defect therein was discovered. ADB SAFEGATE further reserves the right to require the return of such goods to establish any claim.

ADB SAFEGATE's obligation under this guarantee is limited to making repair or replacement within a reasonable time after receipt of such written notice and does not include any other costs such as the cost of removal of defective part, installation of repaired product, labor or consequential damages of any kind, the exclusive remedy being to require such new parts to be furnished.

ADB SAFEGATE's liability under no circumstances will exceed the contract price of goods claimed to be defective. Any returns under this guarantee are to be on a transportation charges prepaid basis. For products not manufactured by, but sold by ADB SAFEGATE, warranty is limited to that extended by the original manufacturer.

This is ADB SAFEGATE's sole guarantee and warranty with respect to the goods; there are no express warranties or warranties of fitness for any particular purpose or any implied warranties of fitness for any particular purpose or any implied warranties other than those made expressly herein. All such warranties being expressly disclaimed.

## Liability

---



### WARNING

Use of the equipment in ways other than described in the catalogue leaflet and the manual may result in personal injury, death, or property and equipment damage. Use this equipment only as described in the manual.

---

ADB SAFEGATE cannot be held responsible for injuries or damages resulting from non-standard, unintended uses of its equipment. The equipment is designed and intended only for the purpose described in the manual. Uses not described in the manual are considered unintended uses and may result in serious personal injury, death or property damage.

Unintended uses includes the following actions:

- Making changes to equipment that have not been recommended or described in this manual or using parts that are not genuine ADB SAFEGATE replacement parts or accessories.
- Failing to make sure that auxiliary equipment complies with approval agency requirements, local codes, and all applicable safety standards if not in contradiction with the general rules.
- Using materials or auxiliary equipment that are inappropriate or incompatible with your ADB SAFEGATE equipment.
- Allowing unskilled personnel to perform any task on or with the equipment.

## © ADB SAFEGATE BVBA

This manual or parts thereof may not be reproduced, stored in a retrieval system, or transmitted, in any form or by any means, electronic, mechanical, photocopying, recording, nor otherwise, without ADB SAFEGATE BVBA's prior written consent.

This manual could contain technical inaccuracies or typographical errors. ADB SAFEGATE BVBA reserves the right to revise this manual from time to time in the contents thereof without obligation of ADB SAFEGATE BVBA to notify any person of such revision or change. Details and values given in this manual are average values and have been compiled with care. They are not binding, however, and ADB SAFEGATE BVBA disclaims any liability for damages or detriments suffered as a result of reliance on the information given herein or the use of products, processes or equipment to which this manual refers. No warranty is made that the use of the information or of the products, processes or equipment to which this manual refers will not infringe any third party's patents or rights. The information given does not release the buyer from making their own experiments and tests

# TABLE OF CONTENTS

<b>1.0 Safety</b> .....	<b>1</b>
1.1 Safety Messages.....	1
1.1.1 Introduction to Safety.....	2
1.1.2 Intended Use.....	2
1.1.3 Material Handling Precautions: Storage.....	3
1.1.4 Maintenance Safety.....	3
1.1.5 Material Handling Precautions, ESD.....	3
1.1.6 Arc Flash and Electric Shock Hazard.....	4
<b>2.0 Airfield Lighting Safety Cutout, ALSC</b> .....	<b>5</b>
2.1 About this manual.....	5
2.1.1 Introduction.....	5
2.1.2 How to work with the manual.....	5
<b>3.0 Product Introduction</b> .....	<b>7</b>
3.1 Equipment Description.....	7
3.2 Airfield Lighting Safety Cutout.....	7
<b>4.0 Installation</b> .....	<b>11</b>
4.1 Introduction.....	11
4.2 Unpacking.....	11
4.3 Individual Cutout Installation.....	11
4.3.1 Individual Cutout Mounting.....	12
4.3.2 Mounting Individual Cutouts on Plate.....	13
4.3.3 Mounting Multiple ALSCs Side-By-Side.....	13
4.4 Individual Cutout Wiring.....	14
<b>5.0 Airfield Lighting Series Cutout, (ALSC) Operation</b> .....	<b>17</b>
<b>6.0 Maintenance</b> .....	<b>19</b>
6.1 Maintenance Procedures.....	19
6.2 Megging Circuit.....	19
6.3 Grounding Cover.....	19
<b>A.0 SUPPORT....</b>	<b>21</b>
A.1 ADB Safegate website.....	21
A.2 Recycling.....	22
A.2.1 Local authority recycling.....	22
A.2.2 ADB Safegate recycling.....	22



# 1.0 Safety

## Introduction to Safety

This section contains general safety instructions for installing and using ADB SAFEGATE equipment. Some safety instructions may not apply to the equipment in this manual. Task- and equipment-specific warnings are included in other sections of this manual where appropriate.

## 1.1 Safety Messages

### HAZARD Icons used in the manual

For all HAZARD symbols in use, see the Safety section. All symbols must comply with ISO and ANSI standards.

Carefully read and observe all safety instructions in this manual, which alert you to safety hazards and conditions that may result in personal injury, death or property and equipment damage and are accompanied by the symbol shown below.



**WARNING**

Failure to observe a warning may result in personal injury, death or equipment damage.



**Danger - Risk of electrical shock or ARC FLASH**

Disconnect equipment from line voltage. Failure to observe this warning may result in personal injury, death, or equipment damage. ARC Flash may cause blindness, severe burns or death.



**WARNING - Wear personal protective equipment**

Failure to observe may result in serious injury.



**WARNING - Do not touch**

Failure to observe this warning may result in personal injury, death, or equipment damage.



**CAUTION**

Failure to observe a caution may result in equipment damage.

### Qualified Personnel



**Important Information**

The term **qualified personnel** is defined here as individuals who thoroughly understand the equipment and its safe operation, maintenance and repair. Qualified personnel are physically capable of performing the required tasks, familiar with all relevant safety rules and regulations and have been trained to safely install, operate, maintain and repair the equipment. It is the responsibility of the company operating this equipment to ensure that its personnel meet these requirements.

Always use required personal protective equipment (PPE) and follow safe electrical work practice.

### 1.1.1 Introduction to Safety



#### CAUTION

##### Unsafe Equipment Use

This equipment may contain electrostatic devices, hazardous voltages and sharp edges on components

- Read installation instructions in their entirety before starting installation.
- Become familiar with the general safety instructions in this section of the manual before installing, operating, maintaining or repairing this equipment.
- Read and carefully follow the instructions throughout this manual for performing specific tasks and working with specific equipment.
- Make this manual available to personnel installing, operating, maintaining or repairing this equipment.
- Follow all applicable safety procedures required by your company, industry standards and government or other regulatory agencies.
- Install all electrical connections to local code.
- Use only electrical wire of sufficient gauge and insulation to handle the rated current demand. All wiring must meet local codes.
- Route electrical wiring along a protected path. Make sure they will not be damaged by moving equipment.
- Protect components from damage, wear, and harsh environment conditions.
- Allow ample room for maintenance, panel accessibility, and cover removal.
- Protect equipment with safety devices as specified by applicable safety regulations
- If safety devices must be removed for installation, install them immediately after the work is completed and check them for proper functioning prior to returning power to the circuit.

**Failure to follow this instruction can result in serious injury or equipment damage**

### Additional Reference Materials



#### Important Information

- IEC - International Standards and Conformity Assessment for all electrical, electronic and related technologies.
- IEC 60364 - Electrical Installations in Buildings.
- FAA Advisory: AC 150/5340-26 (current edition), chapter 45, section 4, Maintenance of Airport Visual Aid Facilities.
- Maintenance personnel must refer to the maintenance procedure described in the ICAO Airport Services Manual, Part 9.
- ANSI/NFPA 79, Electrical Standards for Metalworking Machine Tools.
- National and local electrical codes and standards.

### 1.1.2 Intended Use



#### CAUTION

##### Use this equipment as intended by the manufacturer

This equipment is designed to perform a specific function, do not use this equipment for other purposes

- Using this equipment in ways other than described in this manual may result in personal injury, death or property and equipment damage. Use this equipment only as described in this manual.

**Failure to follow this instruction can result in serious injury or equipment damage**



### 1.1.3 Material Handling Precautions: Storage



#### CAUTION

##### Improper Storage

Store this equipment properly

- If equipment is to be stored prior to installation, it must be protected from the weather and kept free of condensation and dust.

**Failure to follow this instruction can result in equipment damage**

### 1.1.4 Maintenance Safety



#### DANGER

##### Electric Shock Hazard

This equipment may contain electrostatic devices

- Do not operate a system that contains malfunctioning components. If a component malfunctions, turn the system OFF immediately.
- Disconnect and lock out electrical power.
- Allow only qualified personnel to make repairs. Repair or replace the malfunctioning component according to instructions provided in its manual.

**Failure to follow these instructions can result in death or equipment damage**

### 1.1.5 Material Handling Precautions, ESD



#### CAUTION

##### Electrostatic Sensitive Devices

This equipment may contain electrostatic devices

- Protect from electrostatic discharge.
- Electronic modules and components should be touched only when this is unavoidable e.g. soldering, replacement.
- Before touching any component of the cabinet you shall bring your body to the same potential as the cabinet by touching a conductive earthed part of the cabinet.
- Electronic modules or components must not be brought in contact with highly insulating materials such as plastic sheets, synthetic fiber clothing. They must be laid down on conductive surfaces.
- The tip of the soldering iron must be grounded.
- Electronic modules and components must be stored and transported in conductive packing.

**Failure to follow this instruction can result in equipment damage**

### 1.1.6 Arc Flash and Electric Shock Hazard



## DANGER

### Series Circuits have Hazardous Voltages

This equipment produces high voltages to maintain the specified current - Do NOT Disconnect while energized.

- Allow only qualified personnel to perform maintenance, troubleshooting, and repair tasks.
- Only persons who are properly trained and familiar with ADB SAFEGATE equipment are permitted to service this equipment.
- An open airfield current circuit is capable of generating >5000 Vac and may appear OFF to a meter.
- Never unplug a device from a constant current circuit while it is operating; Arc flash may result.
- Disconnect and lock out electrical power.
- Always use safety devices when working on this equipment.
- Follow the recommended maintenance procedures in the product manuals.
- Do not service or adjust any equipment unless another person trained in first aid and CPR is present.
- Connect all disconnected equipment ground cables and wires after servicing equipment. Ground all conductive equipment.
- Use only approved ADB SAFEGATE replacement parts. Using unapproved parts or making unapproved modifications to equipment may void agency approvals and create safety hazards.
- Check the interlock systems periodically to ensure their effectiveness.
- Do not attempt to service electrical equipment if standing water is present. Use caution when servicing electrical equipment in a high-humidity environment.
- Use tools with insulated handles when working with airfield electrical equipment.

**Failure to follow these instructions can result in death or equipment damage**

---

## 2.0 Airfield Lighting Safety Cutout, ALSC

Description: Provides users with a reference for the Airfield Lighting Safety Cutout (ALSC) which is used to isolate the field circuit from the constant current regulator (CCR) for testing or maintenance.

### 2.1 About this manual

#### 2.1.1 Introduction

The manual shows the information necessary to:

- Install and operate the Airfield Lighting Safety Cutout (ALSC).

#### 2.1.2 How to work with the manual

1. Become familiar with the structure and content.
2. Carry out the actions completely and in the given sequence.



## 3.0 Product Introduction

The Airfield Lighting Safety Cutout (ALSC) is used to isolate the field circuit from the constant current regulator (CCR) for testing or maintenance.

### 3.1 Equipment Description

The ALSC replaces the industry standard "S1 Cutout" and provides additional features designed specifically for maintenance personnel. The ALSC consists of a base unit and a series of removable handles that provide a convenient means of testing the field circuit without disconnecting the field cables from the CCR.

### 3.2 Airfield Lighting Safety Cutout

#### Compliance with Standards

FAA:	AC 150/5340-30, Design and Installation Details for Airport Visual Aids.
ICAO:	Aerodrome Design Manual Doc 9157, Part 5.
T/C:	Aerodrome Standards and Recommended Practices, Volume 1, TP-312. Canadian Department of National Defence Standards.

#### Uses

The Airfield Lighting Safety Cutout (ALSC) is used to isolate the field circuit from the constant current regulator (CCR) for testing or maintenance. The ALSC replaces the industry standard "S1 Cutout" and provides additional features designed specifically for maintenance personnel. The ALSC consists of a base unit and a series of removable handles that provide a convenient means of testing the field circuit without disconnecting the field cables from the CCR. The ALSC can be installed next to or within a CCR, or in a separate cutout enclosure.

#### Features

- Compatible with all types of L-828/L-829 CCRs and L-847 circuit selectors operating at 6.6A or 20A output current.
- Designed to operate at 5000 Volts and withstand a hi-pot test of 23KV for 1 minute (required for a 30KW CCR operating at 6.6A output). Most series cutouts are not able to meet this requirement.
- Designed for reliable operation from  $-55^{\circ}\text{C}$  to  $+55^{\circ}\text{C}$  and in areas of high humidity.
- Constructed from a special flame retardant cast epoxy resin for superior insulating properties, impact strength, crack and shatter resistance, and chemical resistance.
- With its high insulation properties and the smallest footprint on the market, the ALSC can be installed within a CCR, or multiple units can be installed in close proximity in a compact cutout enclosure.
- Designed as a replacement for existing S1 cutouts, the ALSC will fit in the space available.
- The base unit comes complete with a removable "In-service" handle. When removed, the field circuit is isolated from the CCR.
- Removing the handle provides a visible means of isolation, ensuring that the field circuit is isolated from the power source (CCR).
- The ALSC can be padlocked in the open position, preventing the handle from being inserted. This is an added safety feature that can be used with the airport's lockout / tagout procedure.
- If the "In-service" handle is rotated  $90^{\circ}$ , the output of the CCR is shorted for testing purposes. The field circuit is also shorted for maintenance continuity checks.

- Handles are ergonomically designed to make insertion and extraction effortless.
- Test Handles can be inserted into the base unit to provide the following maintenance functions:
  - Meggering of field circuit cables without the need to disconnect the cables from the CCR.
  - Intentionally grounding one side of the field cable during operation, to assist in locating a ground in the field.
  - Testing the CCR using a resistive load bank without the need to remove field cables.

**Ordering Code** **ALSC**

ALSC Safety Cutout comes with In-service and shorting plate.

**Optional Test Plates**

IRMS (Megger) Test Plate	ALSC-01
Circuit Grounded Test Plate	ALSC-02
Resistive Load Bank Test Plate	ALSC-03

**Outline Drawing**

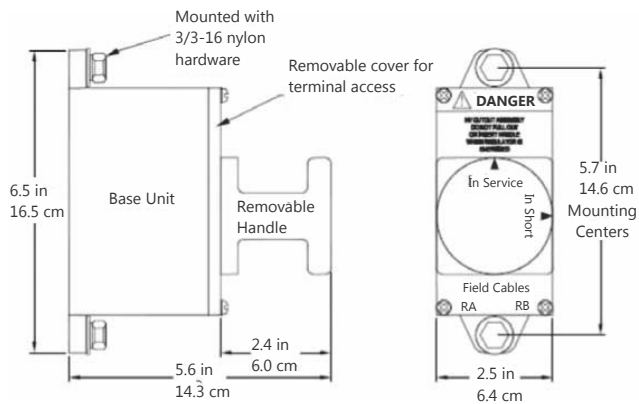

## Handle Options

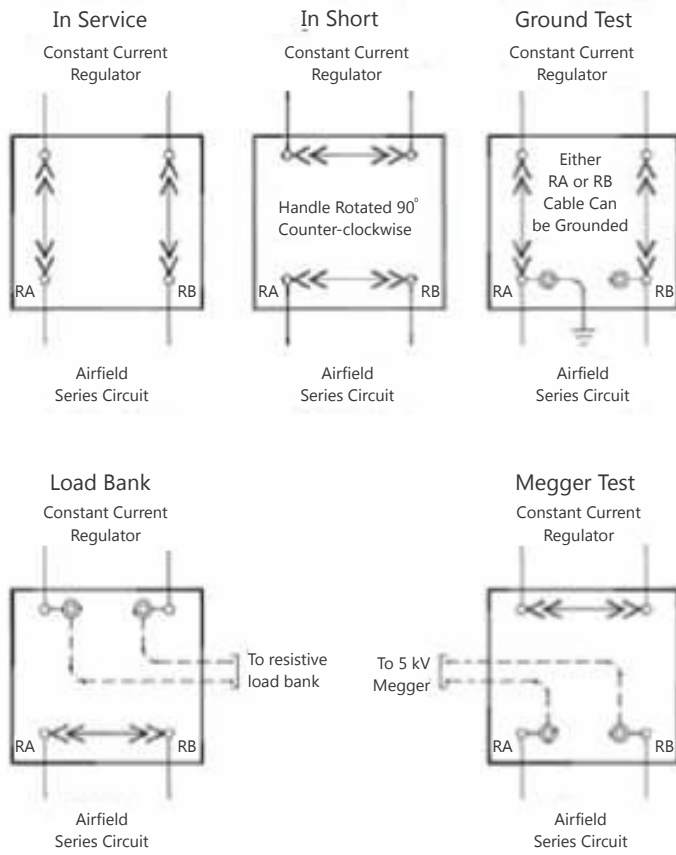





## 4.0 Installation



### WARNING

Read installation instructions in their entirety before starting installation.

- Become familiar with the general safety instructions in this section of the manual before installing, operating, maintaining or repairing this equipment.
- Read and carefully follow the instructions throughout this manual for performing specific tasks and working with specific equipment.
- Make this manual available to personnel installing, operating, maintaining or repairing this equipment.
- Follow all applicable safety procedures required by your company, industry standards and government or other regulatory agencies.
- Install all electrical connections to local code.
- Use only electrical wire of sufficient gauge and insulation to handle the rated current demand. All wiring must meet local codes.
- Route electrical wiring along a protected path. Make sure they will not be damaged by moving equipment.
- Protect components from damage, wear, and harsh environment conditions.
- Allow ample room for maintenance, panel accessibility, and cover removal.
- Protect equipment with safety devices as specified by applicable safety regulations.
- If safety devices must be removed for installation, install them immediately after the work is completed and check them for proper functioning prior to returning power to the circuit.

**Failure to follow these warnings may result in serious injury or equipment damage.**

### 4.1 Introduction

This section provides installation instructions for the ALSC. It includes equipment unpacking, individual cutout installation, cutout wiring, and pre-installed cutout installation. Wiring instructions for pre-installed cutouts are provided in *Pre-Installed Cutout Installation* in this section.

A cutout can be installed individually on or close to a constant current regulator (CCR). It can also be incorporated inside other equipment. Examples would be in a bay on a SwitchGear regulator system or internal to a ADB Safegate CCR. It can also be incorporated inside other equipment.

### 4.2 Unpacking

The equipment is shipped ready for installation. Handle equipment very carefully to prevent component damage. Unpack the carton upon receipt and check the contents and their condition. Note any exterior damage to the carton that might lead to detection of equipment damage.

If you note any damage to any equipment, file a claim with the carrier immediately. The carrier may need to inspect the equipment.

The carton contains the following:

- ALSC
- Instruction Manual

### 4.3 Individual Cutout Installation

This subsection provides information about installing individual ALSCs. It includes individual cutout mounting and wiring. It also includes pre-installed cutout installation.

### 4.3.1 Individual Cutout Mounting

The series cutout can be installed in the vault substation, in the vicinity of the CCR to which it is connected. For example, the cutout can be mounted in the following ways:

- On the wall or rack (Unistrut® or similar type of channel) beside the CCR
- In a "Field Junction Box" containing a large number of cutouts
- In a separate enclosure beside the CCR

In case L-847 circuit selectors are used, the cutouts may be used on either side (input or output) of the selectors, but preferably on the output side (one cutout for each series circuit). Some installations use a cutout on both the input and outputs of the L-847.



#### Warning

- When using the ALSC with a circuit selector, the regulator must be turned off and locked out before performing any insulation resistance measurements. To operate the regulator without erratic results, all ALSs must be returned to the normal operating position.
- To test the regulator under short circuit conditions, all ALSs after the circuit selector must be in the test & measurement position.



#### CAUTION

- Mount the ALSC only on a flat surface. Do not mount the ALSC directly on a Unistrut™ channel or other similar channels. Mounting the cutout on a Unistrut channel may cause the ear of the cutout to crack since the channel is unsupported. If you must install the cutout on a Unistrut channel, fasten a customer-supplied ¼-in.-thick mounting plate to the channel and then fasten the cutout to the plate. See [Figure 1](#) for a drilling template.

Figure 1: Drilling Template

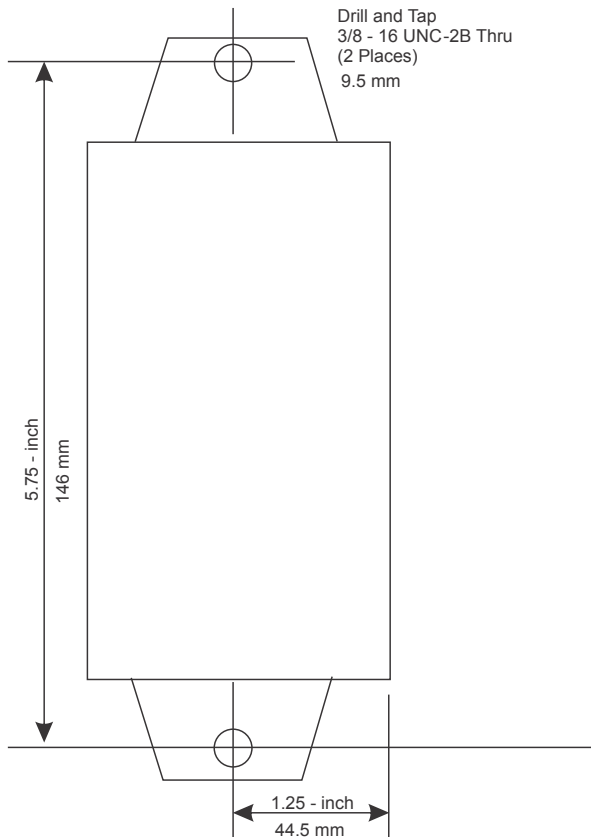

Individual ALSCs are normally mounted on a plate or in a NEMA enclosure. Multiple cutouts can also be mounted side-by-side on a plate or in a NEMA enclosure.



**Note**

If the interlock switch is wired from behind the panel (in line with the interlock switch), then drill a hole as shown in figure 2. Be sure to de-bur the hole and place a spiral wrap around the wire leads. If the interlock switch is wired by cutting the thin wall in the cutout body, then drill the hole in the lower right portion of the plate outside the perimeter of the cutout and use a conventional grommet to protect the wire leads.

**4.3.2 Mounting Individual Cutouts on Plate**

To mount an individual ALSC on a plate, perform the following procedure:

1. Drill two holes on the plate.
2. Tap 3/8-16 x 1 UNC as shown in Figure 1.

**4.3.3 Mounting Multiple ALSCs Side-By-Side**

See Figure 2 for mounting multiple ALSCs side-by-side. This ensures that enough room exists to operate the ALSC.

**Figure 2: Installing Multiple Cutouts**

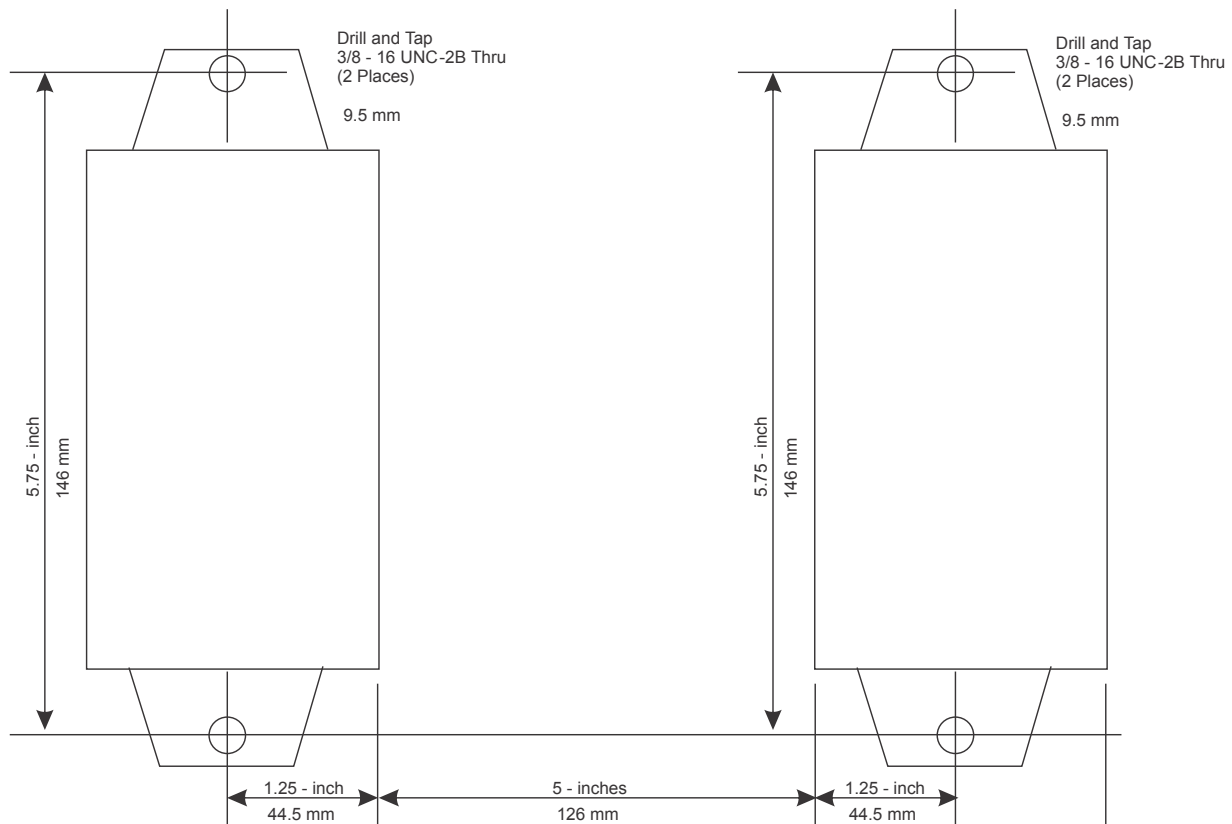

## 4.4 Individual Cutout Wiring

The CCR and load sides of the cutout are clearly marked and must not be reversed. See [Figure 3](#).

**Figure 3: CCR Wiring Diagrams**

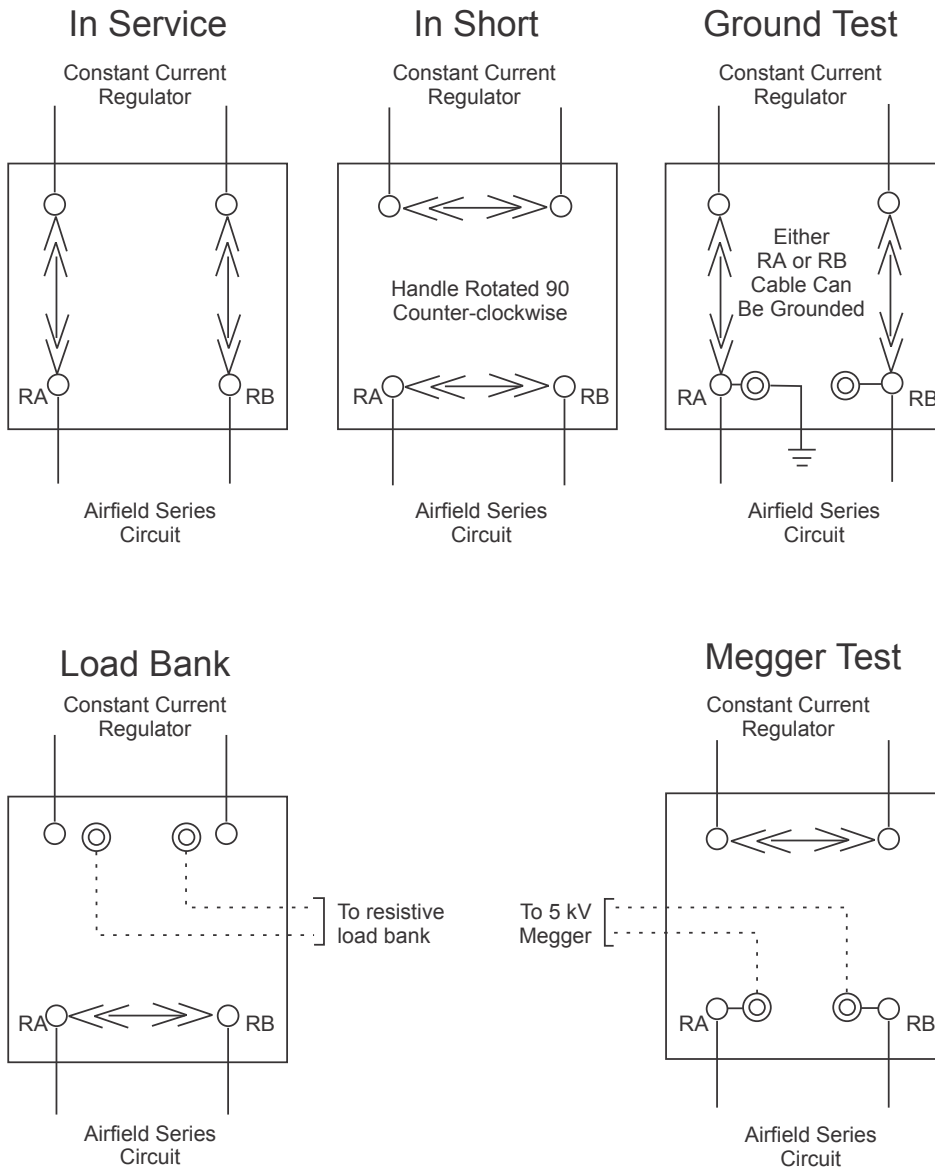

### CAUTION

ALSC should not be wired in any manner other than described in this manual without the approval of ADB Safegate.

To wire the ALS, perform the following procedure:

If using unshielded L-824 wire, connect the CCR input and output wires to the ALS by performing the following procedure:

- a) Strip the input and output cable wires to 1/2 in.

(13.0 mm) from the end of the wire. See [Figure 4](#). Make sure that the wire strands are not nicked or cut.

**Figure 4: Stripping Unshielded L-824 Wire**  
Input/Output Cable

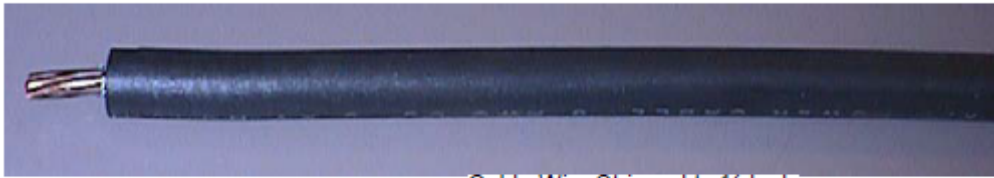

½ in. (13 mm)  
16 mm max.

Cable Wire Stripped to ½ Inch

- b) See [Figure 3](#).  
Connect the input L-824 wire to the ALSC.



**Note**

Do not allow the end of the cable wire to extend beyond the input post more than 1/16 of an inch.

- c) Connect the output L-824 wire (4) to the ALSC.  
d) Close the ALSC.



## 5.0 Airfield Lighting Series Cutout, (ALSC) Operation



### CAUTION

#### IMPROPER OPERATION; Arc Flash

Secure Power Prior to Switch Manipulation

- Only qualified personnel, physically capable of operating the equipment and with no impairments in their judgment or reaction times, should operate this equipment.
- Read all system component manuals before operating this equipment. A thorough understanding of system components and their operation will help you operate the system safely and efficiently.
- Before starting this equipment, check all safety interlocks, fire-detection systems, and protective devices such as panels and covers. Make sure all devices are fully functional. Do not operate the system if these devices are not working properly. Do not deactivate or bypass automatic safety interlocks or locked-out electrical disconnects.
- Never operate this equipment with a known malfunction.
- Do not attempt to operate or service electrical equipment if standing water is present.
- Use this equipment only in the environments for which it is rated. Do not operate this equipment in humid, flammable, or explosive environments unless it has been rated for safe operation in these environments.
- Never touch exposed electrical connections on equipment while the power is ON.
- Never change ALSC positions while the CCR is operating or has power applied to the circuit.

**Failure to follow this instruction can result in equipment damage or death.**

Refer to [Table 1](#) for the different working positions.

**Table 1: Airfield Lighting Series Cutout, (ALSC) Working Positions**

ALSC	In Service	In Short	Ground Test
Mode of operation	Allows the regulator to deliver current to the series circuit.	Maintenance can be done safely on the series circuit.	The series circuit insulation versus ground can be measured by applying the measurement voltage, max 9000 V DC, between the measurement socket and the ground strip.

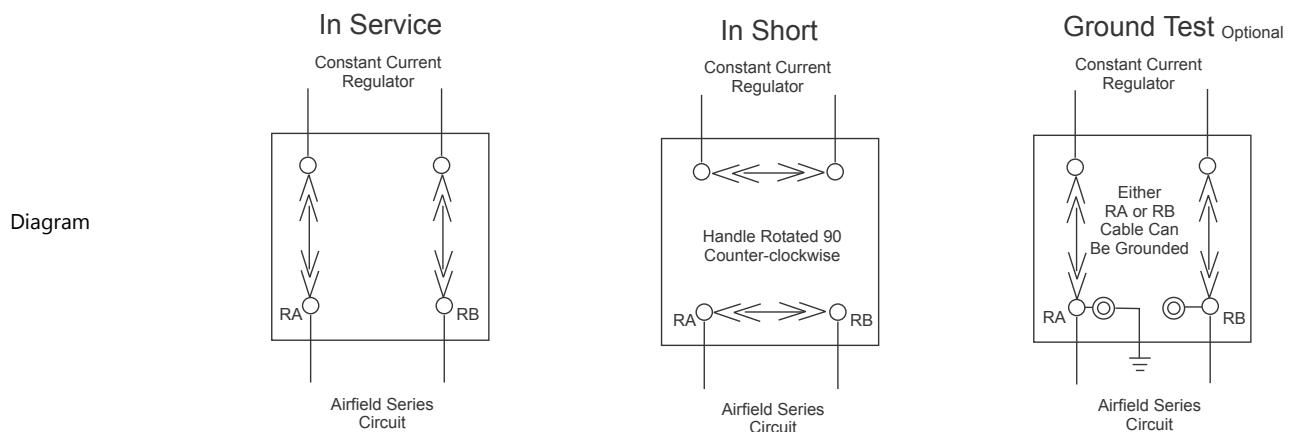

Handle is:	"In Service"	"In Short"	Optional: "Ground Test"
The series circuit is:	connected to the CCR	Disconnected from the CCR, shorted and grounded	Connected to the CCR, one side shorted to ground.
The CCR is:	delivering current to the series circuit	shorted and grounded	delivering current to the Series Circuit

**Table 2: ALSC Load Bank Working Positions**

ALSC	Load Bank	Load Bank Megger Test
Mode of operation	Allows to test the regulator on a known load bank.	Allows the circuit to be megger tested without risk to the CCR.

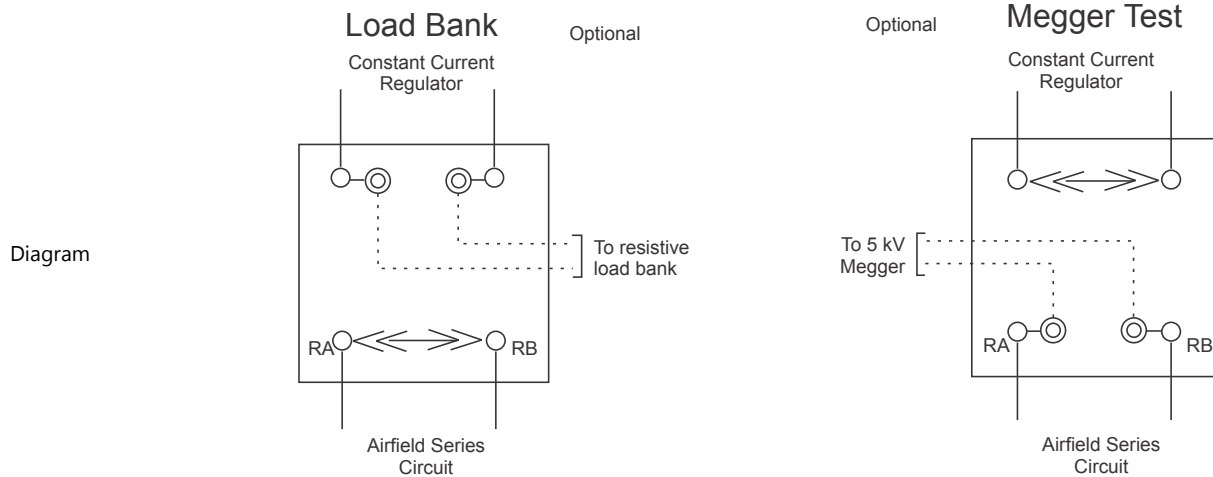

Handle is:	Optional: "Load Bank"	Optional: "Megger Test"
The series circuit is:	Disconnected from CCR and Shorted	Available to attach to a megger
The CCR is:	Output to a load bank	Shorted

1. Switch off the constant current regulator before manipulating the cutout.
2. After the cutout position has been changed and it is seated firmly, turn on the power.
3. Complete the test or procedure.
4. Secure power prior to returning the cutout to the normal position.



## 6.0 Maintenance

### 6.1 Maintenance Procedures



#### DANGER

##### ARC FLASH AND ELECTRIC SHOCK HAZARD

Allow only qualified personnel to perform maintenance, troubleshooting, and repair tasks.

- Only persons who are properly trained and familiar with ADB Safegate equipment are permitted to service this equipment.
- An open airfield current circuit is capable of generating >5000 Vac and may appear OFF to a meter.
- Never unplug a device from a constant current circuit while it is operating. Arc flash may result.
- Disconnect and lock out electrical power.
- Always use safety devices when working on this equipment.
- Follow the recommended maintenance procedures in the product manuals.
- Do not service or adjust any equipment unless another person trained in first aid and CPR is present.
- Connect all disconnected equipment ground cables and wires after servicing equipment. Ground all conductive equipment.
- Use only approved ADB Safegate replacement parts. Using unapproved parts or making unapproved modifications to equipment may void agency approvals and create safety hazards.
- Check the interlock systems periodically to ensure their effectiveness.
- Do not attempt to service electrical equipment if standing water is present. Use caution when servicing electrical equipment in a high- humidity environment.
- Use tools with insulated handles when working with airfield electrical equipment

**Failure to follow these warnings will result in death or equipment damage.**

### 6.2 Megging Circuit

To meg the circuit, perform the following procedure:

1. Turn off and lock out the constant current regulator.
2. Install the optional Megger Test, test plate handle.
3. Place the positive (red) wire of the megger into RA position.
4. Connect the minus (black) wire of the megger into the RB position.



#### Note

The maximum voltage measurement is 9,000 Vdc.

5. Activate the megger and record the resistance reading.
6. When finished, install the standard handle in the "In Service" position.

### 6.3 Grounding Cover

A technique used during series circuit maintenance and troubleshooting procedures is to connect one of the constant current regulator output terminals to earth ground.

The optional Ground Test handle is available to ground one side of the series circuit. Install the optional handle and follow troubleshooting guidelines to determine circuit faults.

Note that the test handle will not effect CCR output in normal operational conditions.



## Appendix A: SUPPORT

Our experienced engineers are available for support and service at all times, 24 hour/7 days a week. They are part of a dynamic organization making sure the entire ADB Safegate is committed to minimal disturbance for airport operations.

**Table 3: ADB Safegate Support**

### Live Technical Support - Americas

If at any time you have a question or concern about your product, just contact ADB's technical service department. Trained in all areas of system issues, troubleshooting, quality control and technical assistance, our highly experienced Technical support specialists are available 24 hours a day, seven days a week to provide assistance over the phone.

**ADB SAFEGATE Americas Technical Service & Support (US & Canada): +1-800-545-4157**

**ADB SAFEGATE Americas Technical Service & Support (International): +1-614-861-1304**

During regular business hours, you can also [Chat with a Service Technician](#). We look forward to working with you!

### Before You Call

When you have an airfield lighting or system control system problem it is our goal to support airfield maintenance staff as quickly as possible. To support this effort we ask that you have the following information ready before calling.

- The airport code
- If not with an airport, then company name (prefer customer id number)
- Contact phone number and email address
- Product with part number preferable or product number
- Have you reviewed the product's manual and troubleshooting guide
- Do you have a True RMS meter available (and any other necessary tools)
- Be located with the product ready to troubleshoot

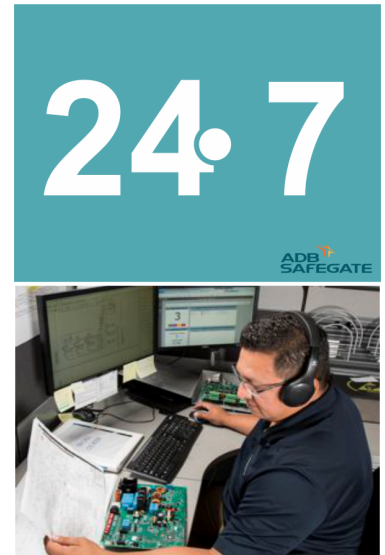

### Note

For more information, see [www.adbsafegate.com](http://www.adbsafegate.com), or contact ADB Safegate Support via email at [support@adbsafegate.com](mailto:support@adbsafegate.com) or

Brussels: +32 2 722 17 11

Europe: +46 (0) 40 699 17 40

Americas: +1 614 861 1304. Press 3 for technical service or press 4 for sales support.

China: +86 (10) 8476 0106

## A.1 ADB Safegate website

The ADB Safegate website, [www.adbsafegate.com](http://www.adbsafegate.com), offers information regarding our airport solutions, products, company, news, links, downloads, references, contacts and more.

## A.2 Recycling

### A.2.1 Local authority recycling

The disposal of ADB Safegate products is to be made at an applicable collection point for the recycling of electrical and electronic equipment. The correct disposal of equipment prevents any potential negative consequences for the environment and human health, which could otherwise be caused by inappropriate waste handling. The recycling of materials helps to conserve natural resources. For more detailed information about recycling of products, contact your local authority city office.

### A.2.2 ADB Safegate recycling

ADB Safegate is fully committed to environmentally-conscious manufacturing with strict monitoring of our own processes as well as supplier components and sub-contractor operations. ADB Safegate offers a recycling program for our products to all customers worldwide, whether or not the products were sold within the EU.

ADB Safegate products and/or specific electrical and electronic component parts which are fully removed/separated from any customer equipment and returned will be accepted for our recycling program.

All items returned must be clearly labelled as follows:

- **For ROHS/WEEE Recycling**
- Sender contact information (Name, Business Address, Phone number).
- Main Unit Serial Number.

ADB Safegate will continue to monitor and update according for any future requirements for EU directives as and when EU member states implement new regulations and or amendments. It is our aim to maintain our compliance plan and assist our customers.

## Company Addresses

ADB SAFEGATE	ADB Safegate Address: Leuvensesteenweg 585, B-1930 Zaventem, Belgium
Contact: Tel.: +32 2 722 17 11, Fax: +32 2 722 17 64	Email: <a href="mailto:marketing@adbsafegate.com">marketing@adbsafegate.com</a> Internet: <a href="http://www.adbsafegate.com">www.adbsafegate.com</a>
ADB SAFEGATE Americas LLC	ADB Safegate, Americas Address: 977 Gahanna Parkway, Columbus, OH 43230 USA
Contact: Tel.: +1 (614) 861 1304, Fax: +1 (614) 864 2069	Email: <a href="mailto:sales.us@adbsafegate.com">sales.us@adbsafegate.com</a> Internet: <a href="http://www.adbsafegate.com">www.adbsafegate.com</a>
ADB SAFEGATE Malmo	ADB Safegate, Sweden Address: Djurhagegatan 19 SE-213 76 Malmö, Sweden Phone: Fax:
Contact: Tel.: +46 (0)40 699 17 00, Fax: +46 (0)40 699 17 30	Email: <a href="mailto:marketing@adbsafegate.com">marketing@adbsafegate.com</a> Internet: <a href="http://www.adbsafegate.com">www.adbsafegate.com</a>
ADB Safegate Airfield Technologies Ltd. China	ADB Safegate, China Address: Unit 603, D Block, CAMIC International Convention Center, No 3, Hua Jia Di East road, ChaoYang district, Beijing 100102, P.R. China
Contact: Tel.: +86 (10) 8476 0106, Fax: +86 (10) 8476 0090	Email: <a href="mailto:china@safegate.com">china@safegate.com</a> Internet: <a href="http://www.adbsafegate.com">www.adbsafegate.com</a>



## Powering Your Airport Performance from Approach to Departure

[adbsafegate.com](https://adbsafegate.com)

Copyright © ADB SAFEGATE, all rights reserved

