

Certikin

Part No.HD108 Water Top Up Unit Installation Instructions

ES Pieza N°HD108 - Unidad de Suministro de Agua Instrucciones de Instalación

D Teil-Nr. HD108 - Wasserzulaufanlage Montageanleitung

IT Codice Articolo HD108 Unita' di Reintegro Acqua Istruzioni per L'Installazione

FR Piece N° HD108 Dispositif d'appoint d'eau Consignes D'installation

PT N° Peça HD108 Unidade de Reposição da água Instruções de Instalação

مصر القطعة رقم 108 HD . جهاز استقدام المياه
تعليمات التركيب

GB

Part No HD108 - Water Top Up Unit Installation Instructions

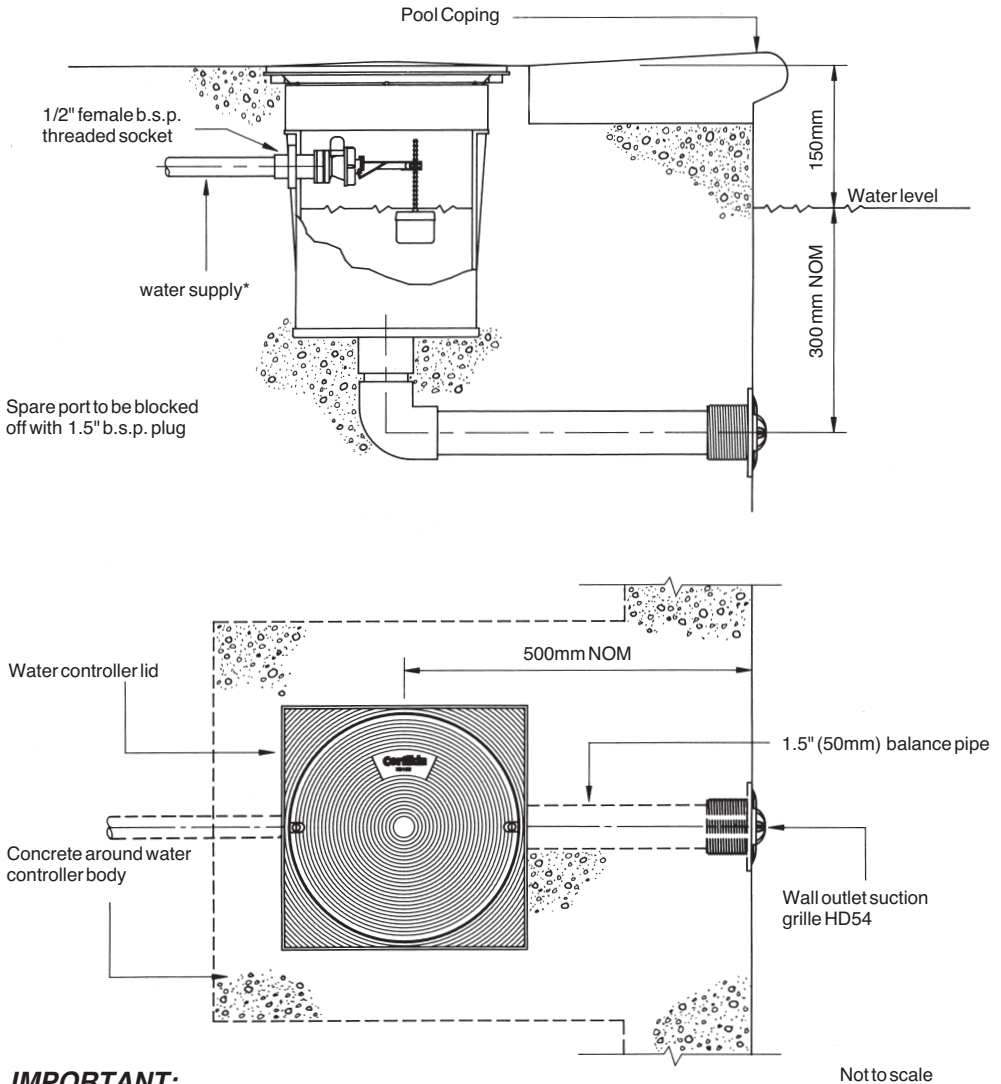
**IMPORTANT:**

Use P.T.F.E. tape to make threaded joints, liquid jointing must not be used

*The water supply to the HD108 must be compliant with local regulations. For the UK, the supply should be via a suitable header tank with an overflow, NOT a direct mains supply. Refer to the supplied filling valve instructions re: pressure restrictors

Pieza N°HD108 - Unidad de Suministro de Agua

Instrucciones de Instalación

ES

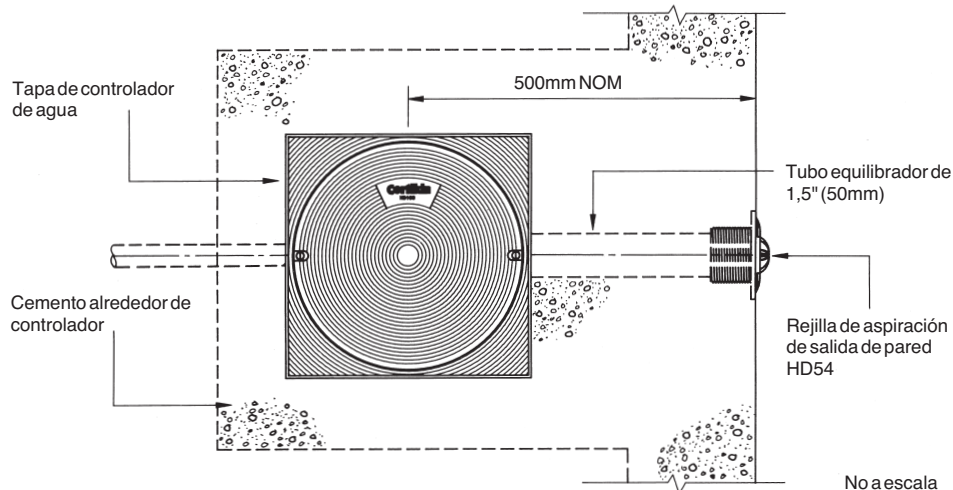
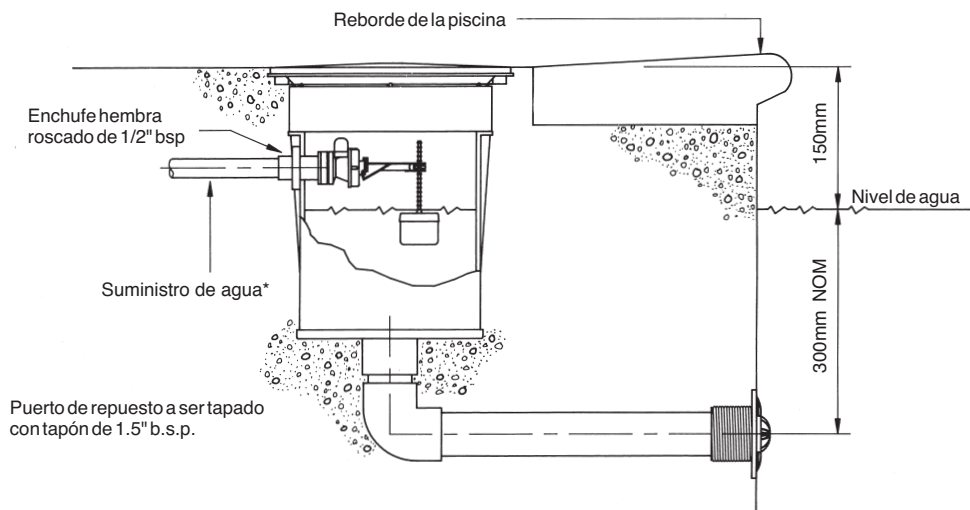

IMPORTANTE:

Use cinta de pte para las conexiones roscadas, no usar conexiones líquidas

*El suministro de agua a la unidad HD108 debe cumplir la reglamentación vigente en el lugar de la instalación.

D

Teil-Nr. HD108 - Wasserzulaufanlage Montageanleitung

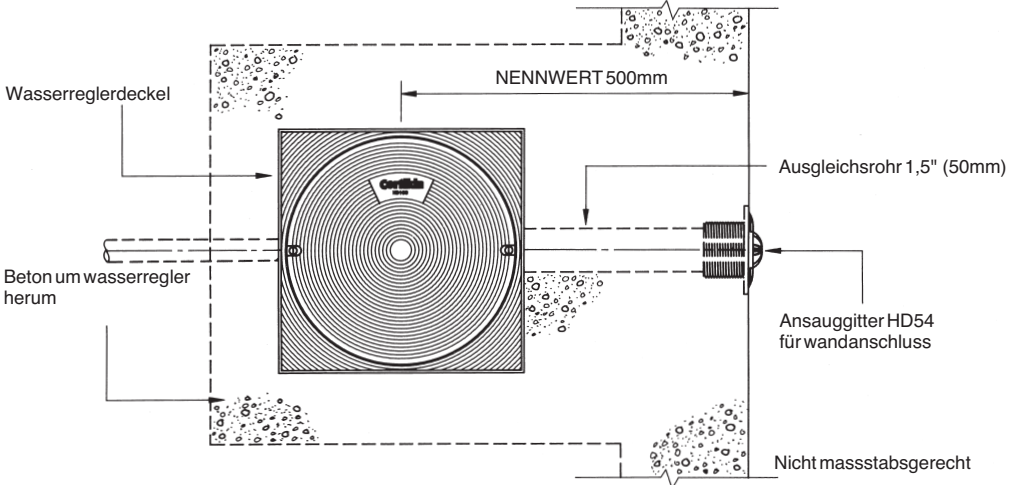
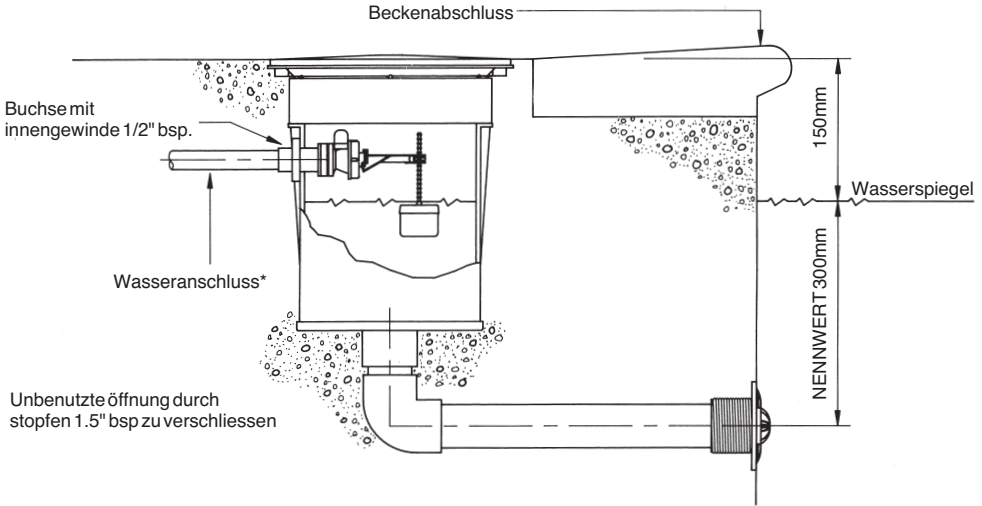

ACHTUNG:

Die verbindung mit pfe-band abdichten. Keinen flüssigzement verwenden.

*Der Wasseranschluss des HD108 muss den örtlichen Vorschriften entsprechen.

Codice Articolo HD108

Unita' di Reintegro Acqua

Istruzioni per L'Installazione

IT

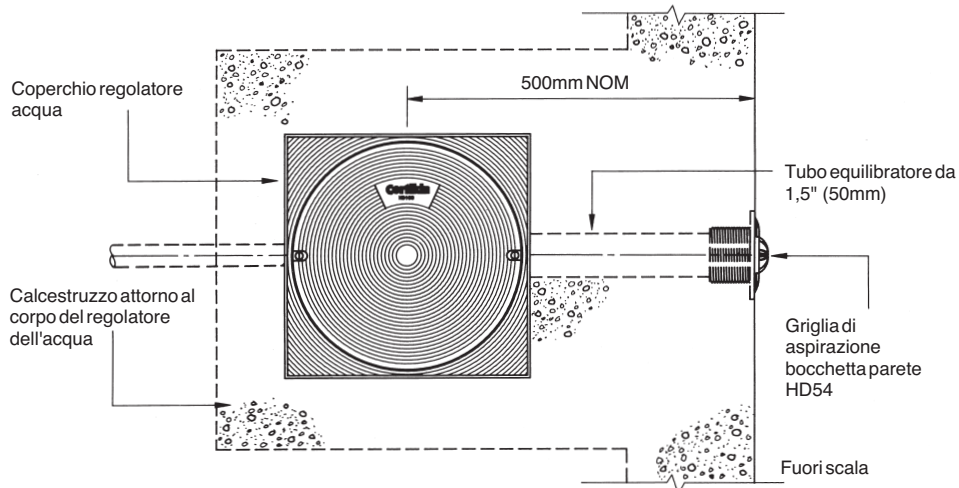
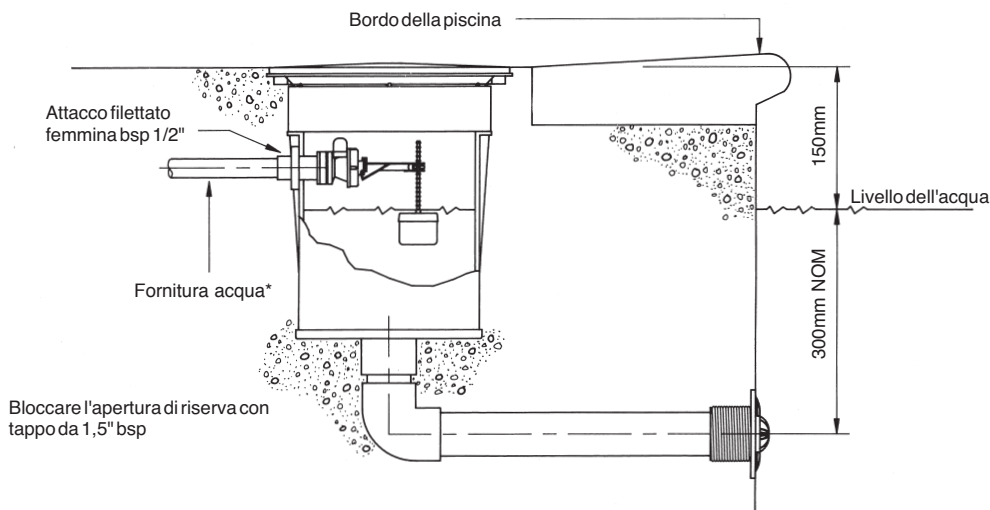

IMPORTANTE:

Usare nastro di ptfе per eseguire la giunzione - non usare ermetico liquido

*La fornitura dell'acqua a HD108 deve essere conforme ai regolamenti locali.

FR

Piece N° HD108

Dispositif d'appoint d'eau

Consignes D'installation

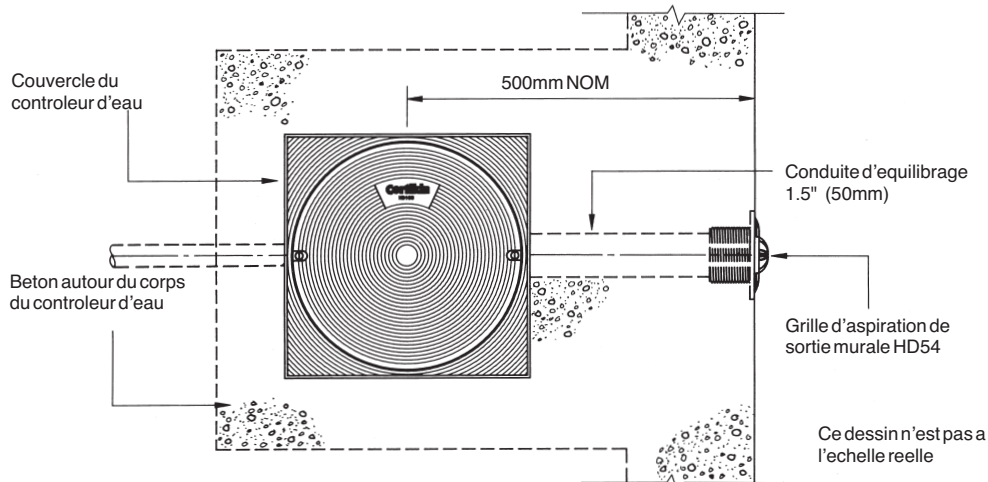
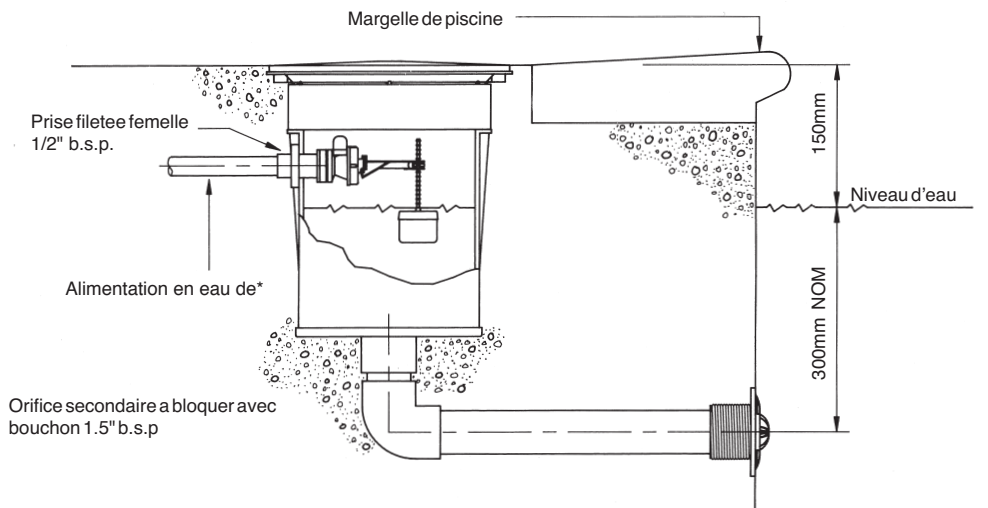

Utiliser un ruban en teflon pour faire des raccords filetes les raccords liquides ne doivent pas être utilisés

*L'alimentation en eau au HD108 doit être conforme à la réglementation locale.

Nº Peça HD108

Unidade de Reposição da água

Instruções de Instalação

PT

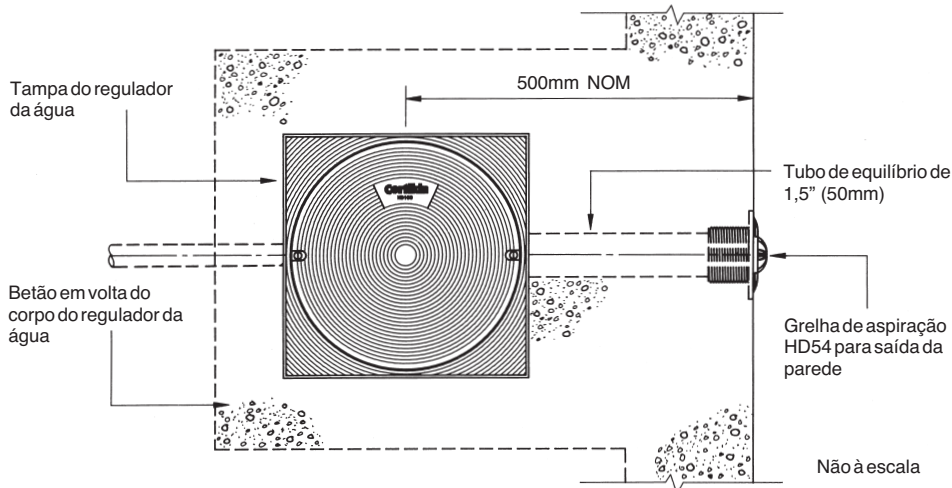
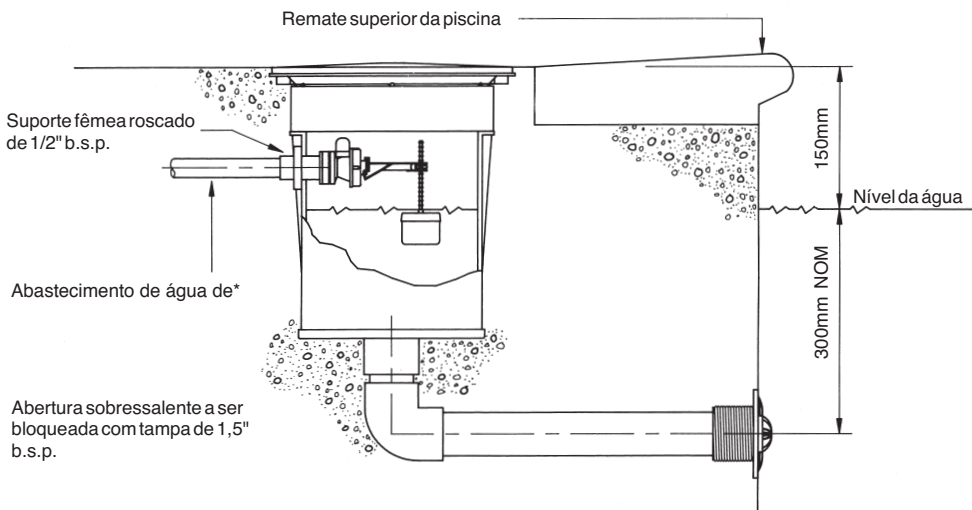

IMPORTANTE:

Usar fita p.t.f.e. para fazer as uniões roscadas, não deverão ser usados solventes líquidos

*O abastecimento de água para o HD108 tem de estar em conformidade com os regulamentos locais.

القطعة رقم HD 108. جهاز استقدام المياه تعليمات التركيب

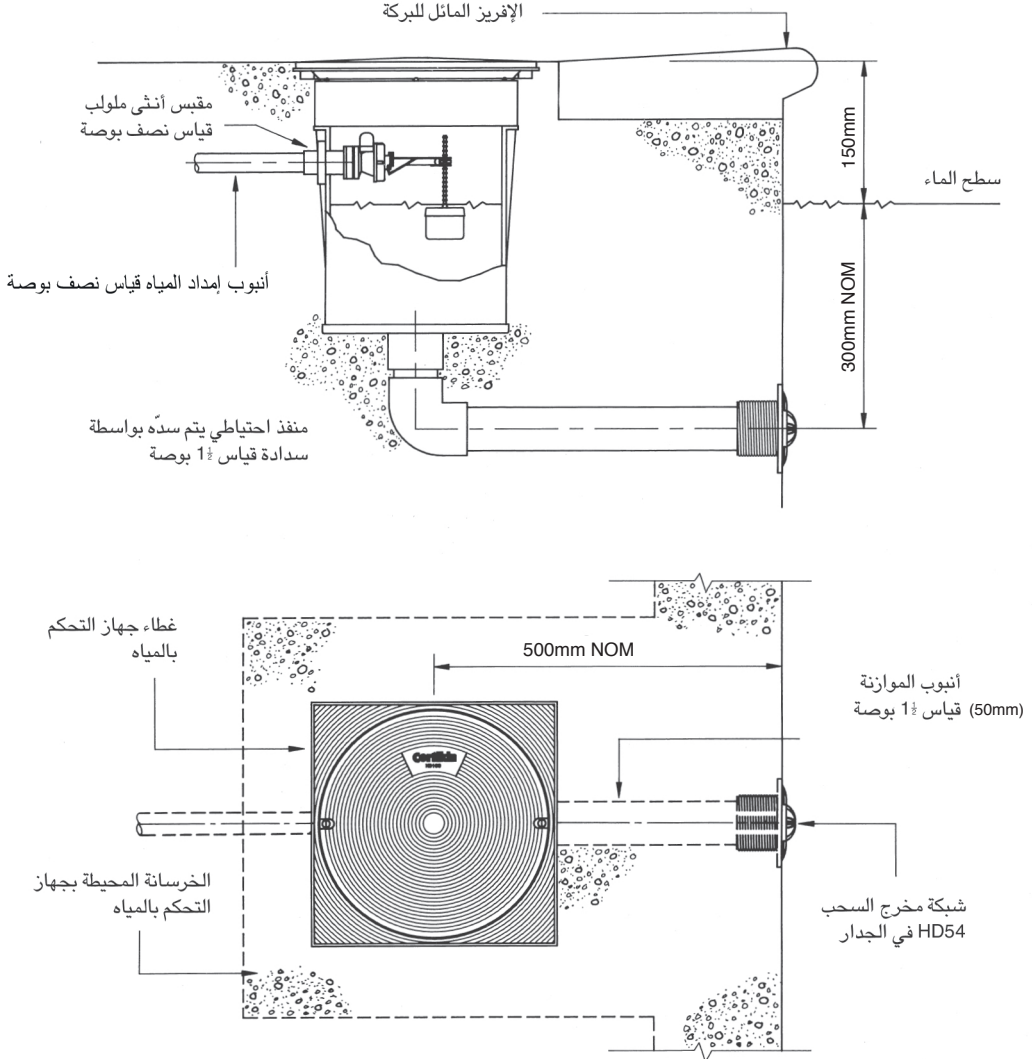

غير متوافق مع المقاسات الحقيقية

ملاحظة هامة:

استعمل شريط تفلون لصنع الوصلة. يجب أن لا تستعمل حشوات من السوائل.

يجب أن يكون إمداد المياه إلى HD108 ممثلًا للوائح المحلية"

Part No HD108 - Water Top Up Unit

GB

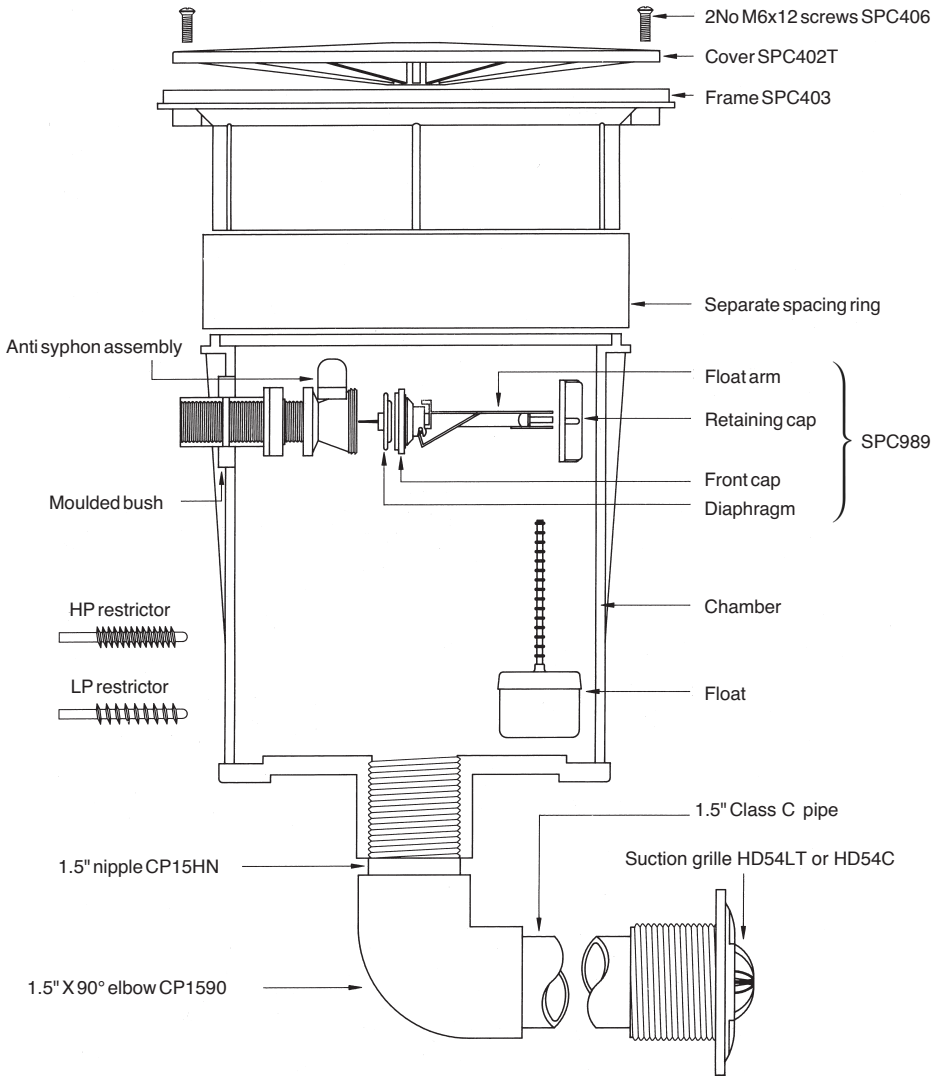

ES

Pieza N°HD108

Unidad de Suministro de Agua

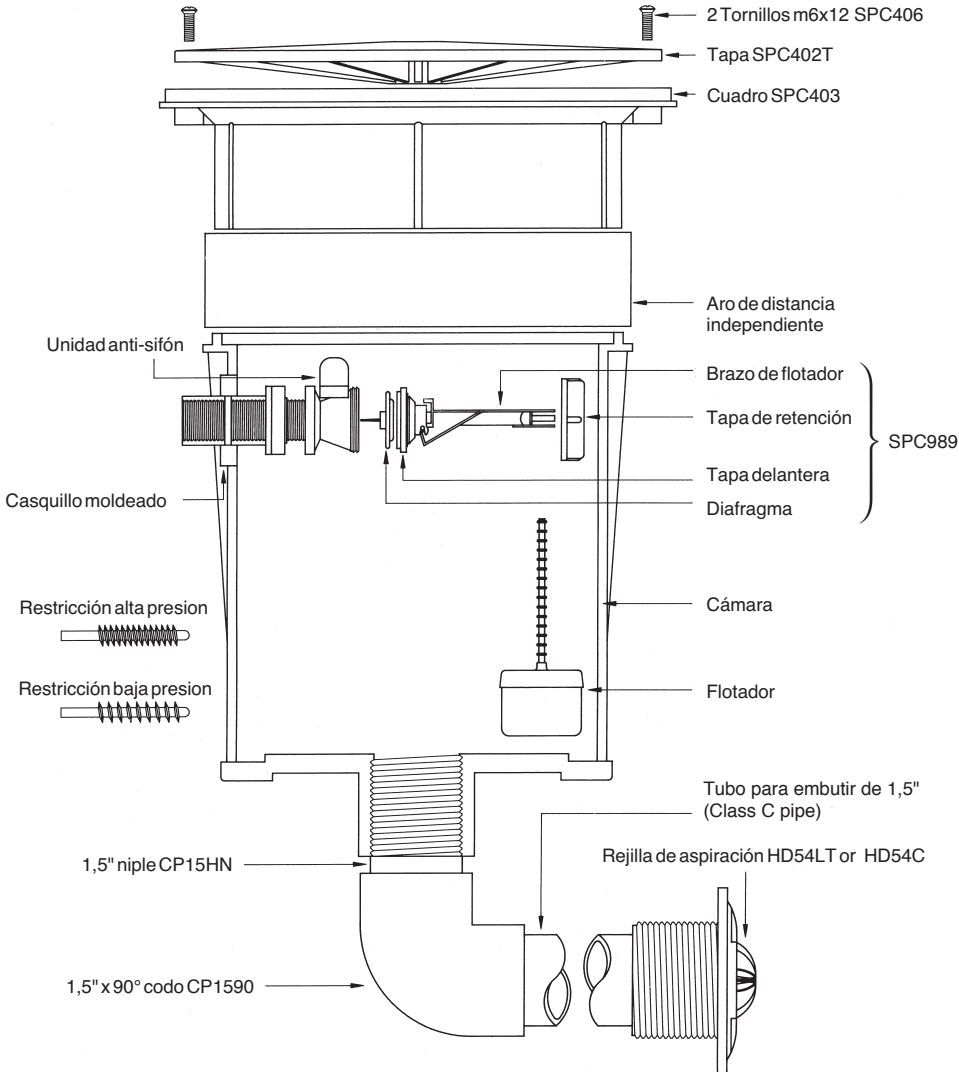

Teil-Nr. HD108 Wasserszufuhranlage

D

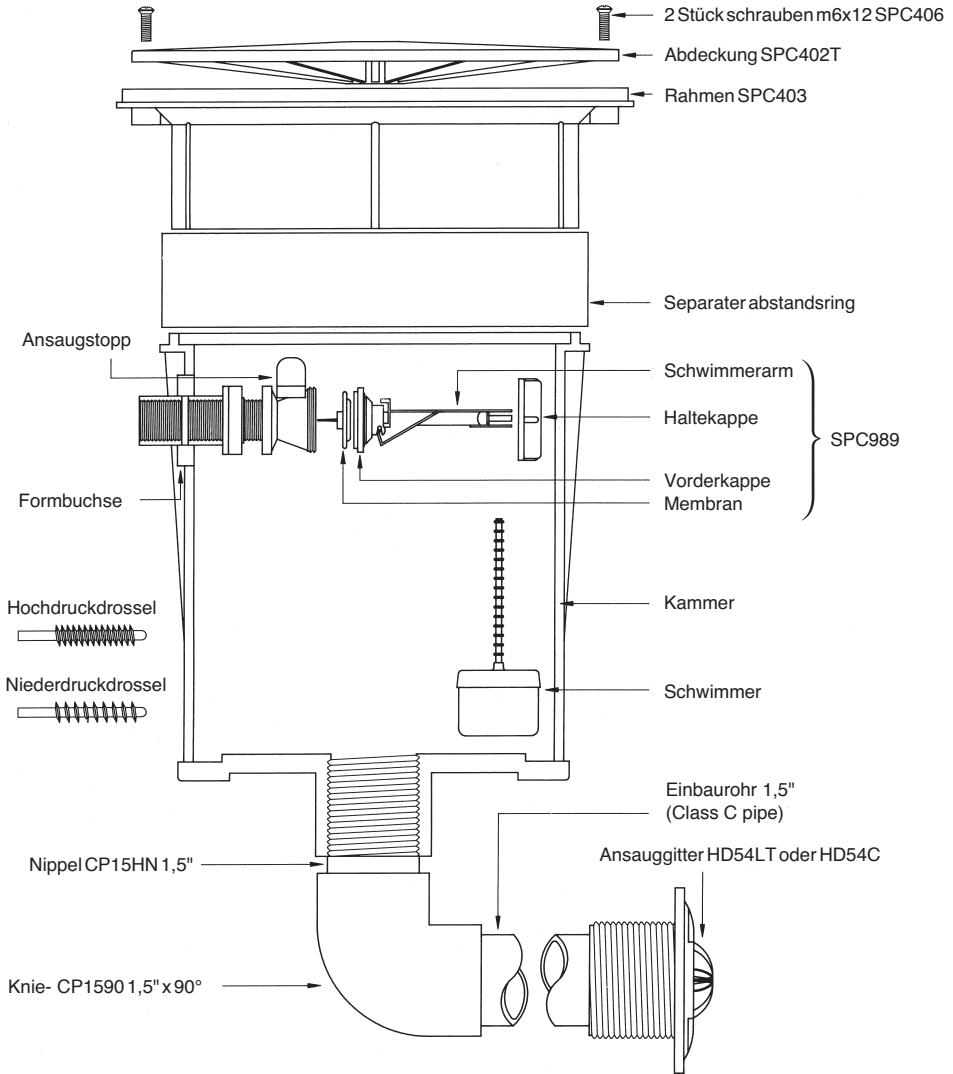

IT

Codice Articolo HD108

Unita' di Reintegro Acqua

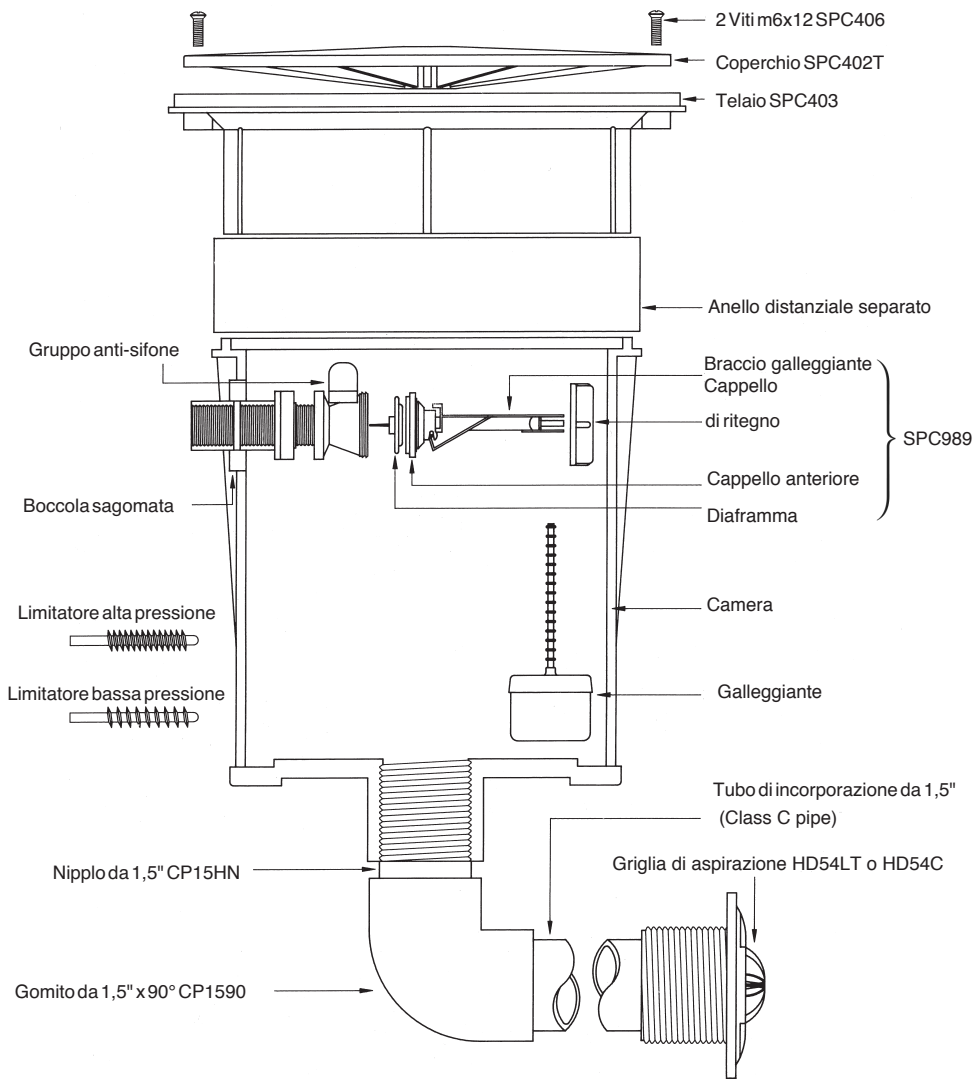

Piece No HD 108

Dispositif d'Appoint d'Eau

FR

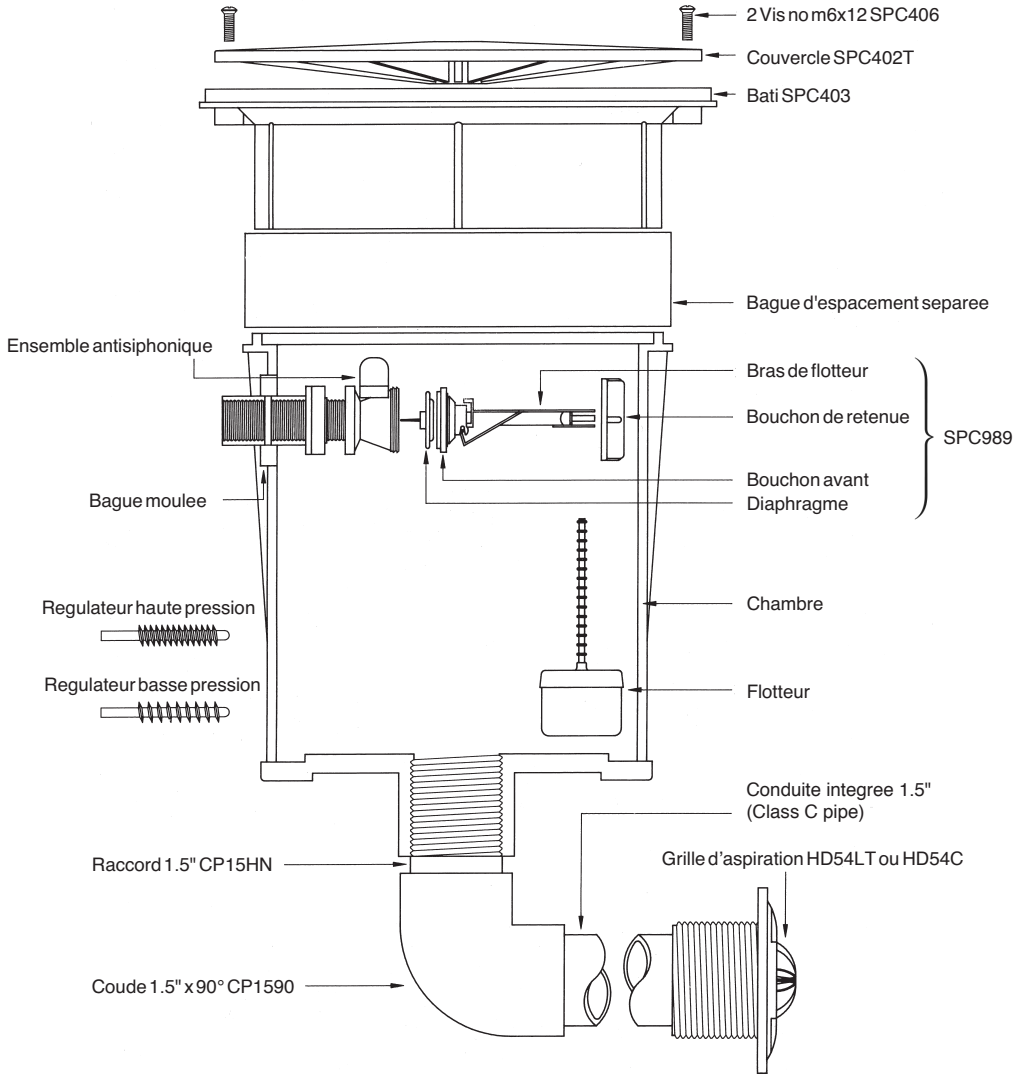

PT

Nº Peça HD108

Unidade de Reposição da Água

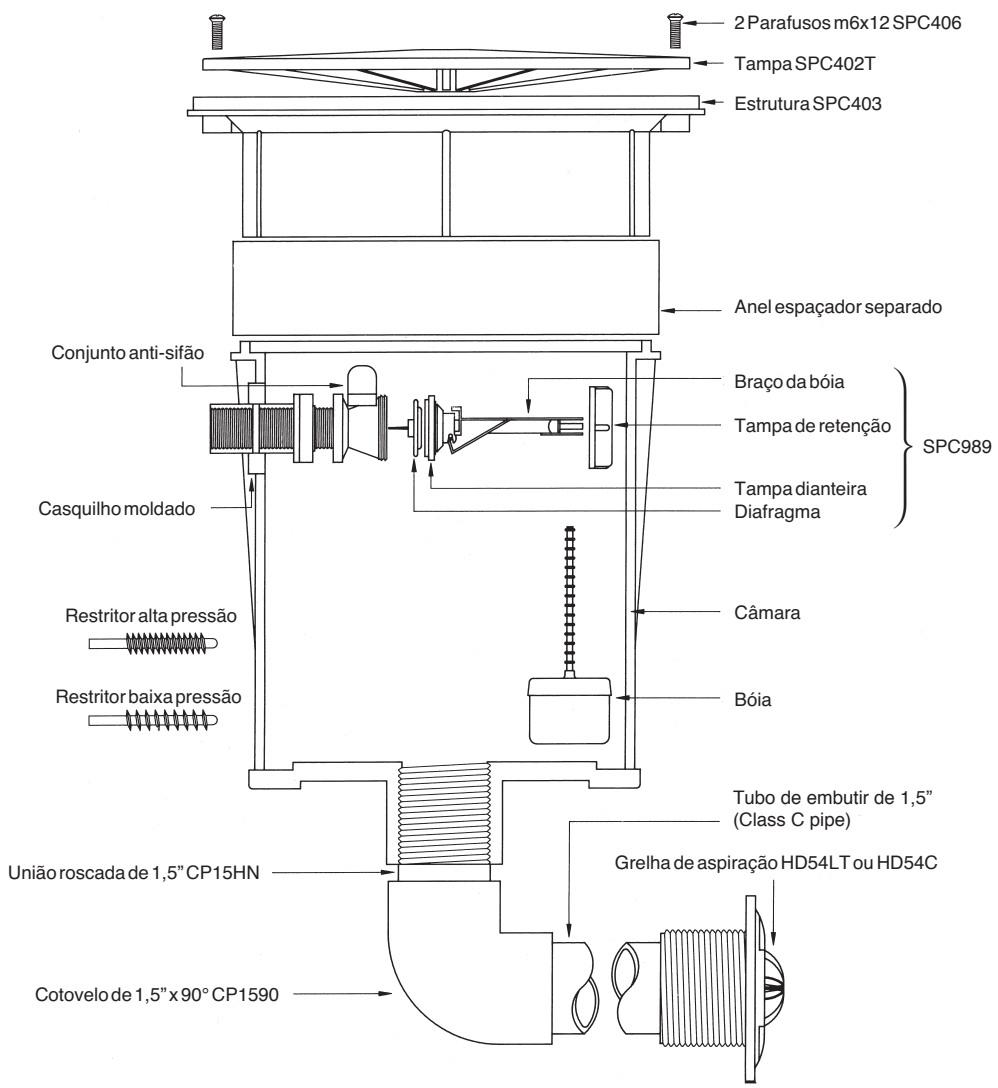

القطعة رقم HD108 جهاز استقدام المياه

مصر

