

BIO UV
 ZAC DE LA PETITE CAMARGUE
 34400 LUNEL

DRAWN :	Geoffroy Gresse			
CHECKED :				
DATE OF CREATION :	23/10/08			
INDEX	DATE	MODIFICATION	DES.	

Document n° :

MP 340 EL
 POWER 1/2

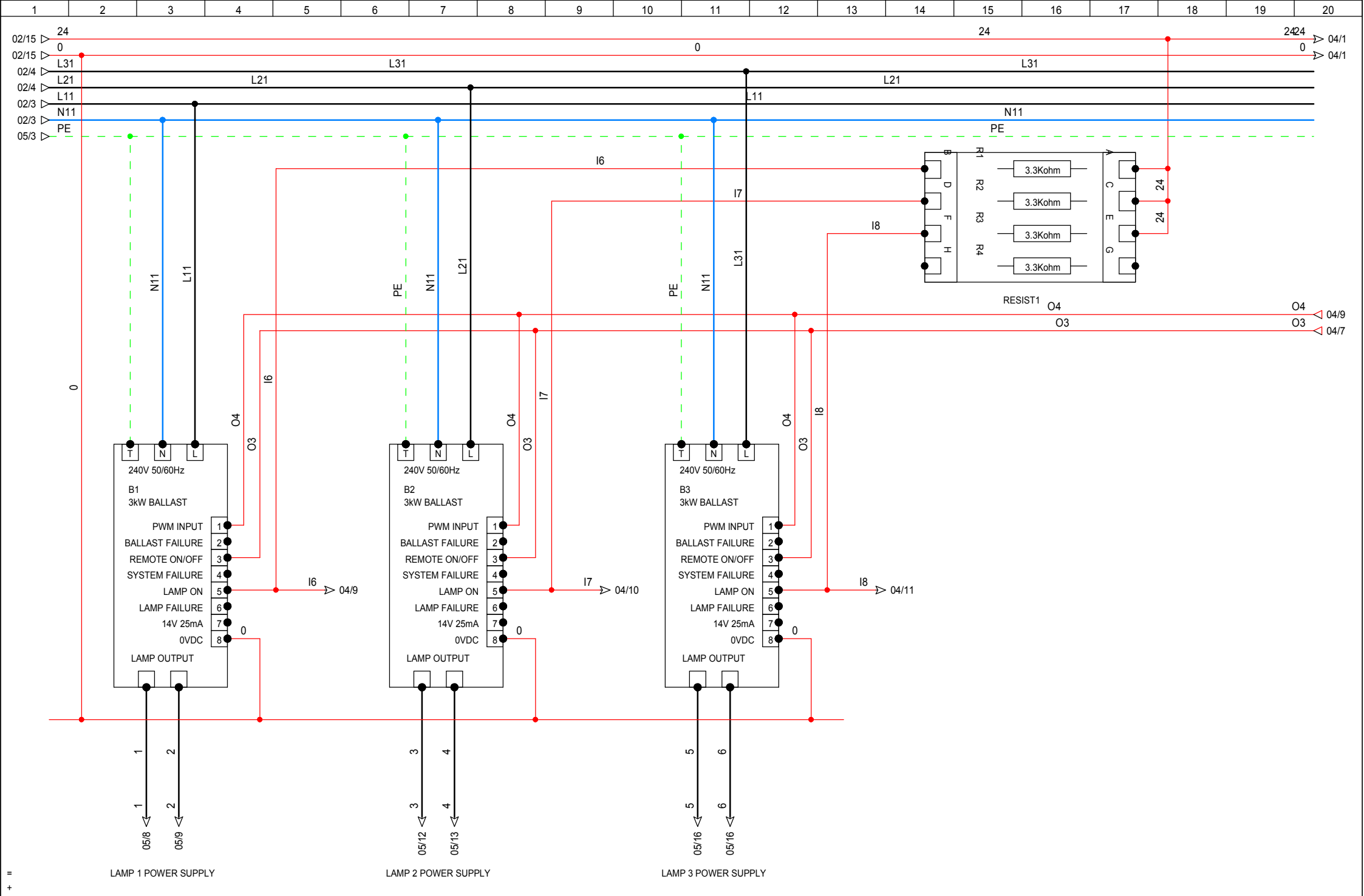

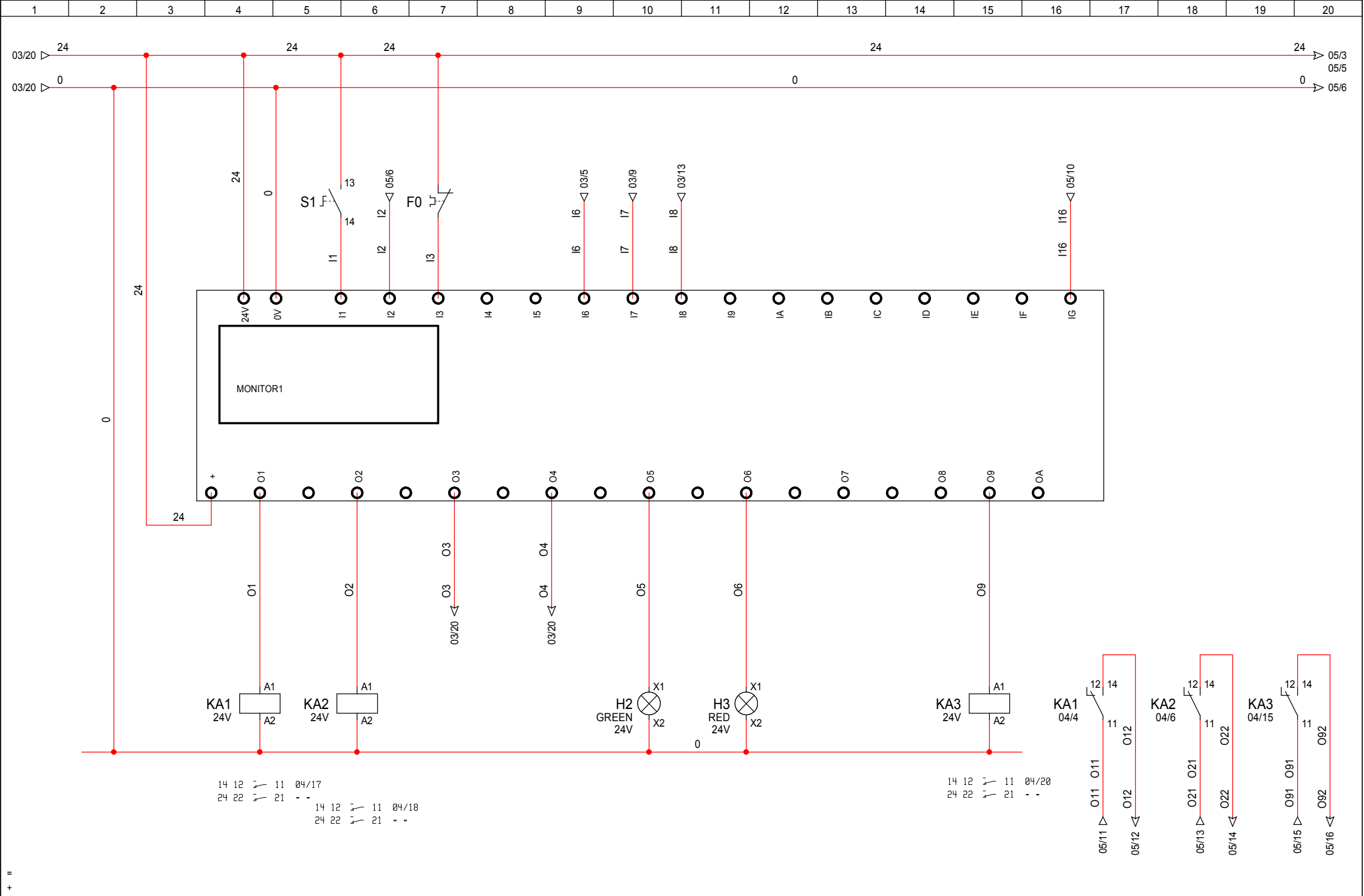

BIO UV
 ZAC DE LA PETITE CAMARGUE
 34400 LUNEL

DRAWN :	Geoffroy Gresse			
CHECKED :				
DATE OF CREATION :	23/10/08	INDEX	DATE	MODIFICATION
				DES.

Document n° :

MP 340 EL
 COMMAND 2/2

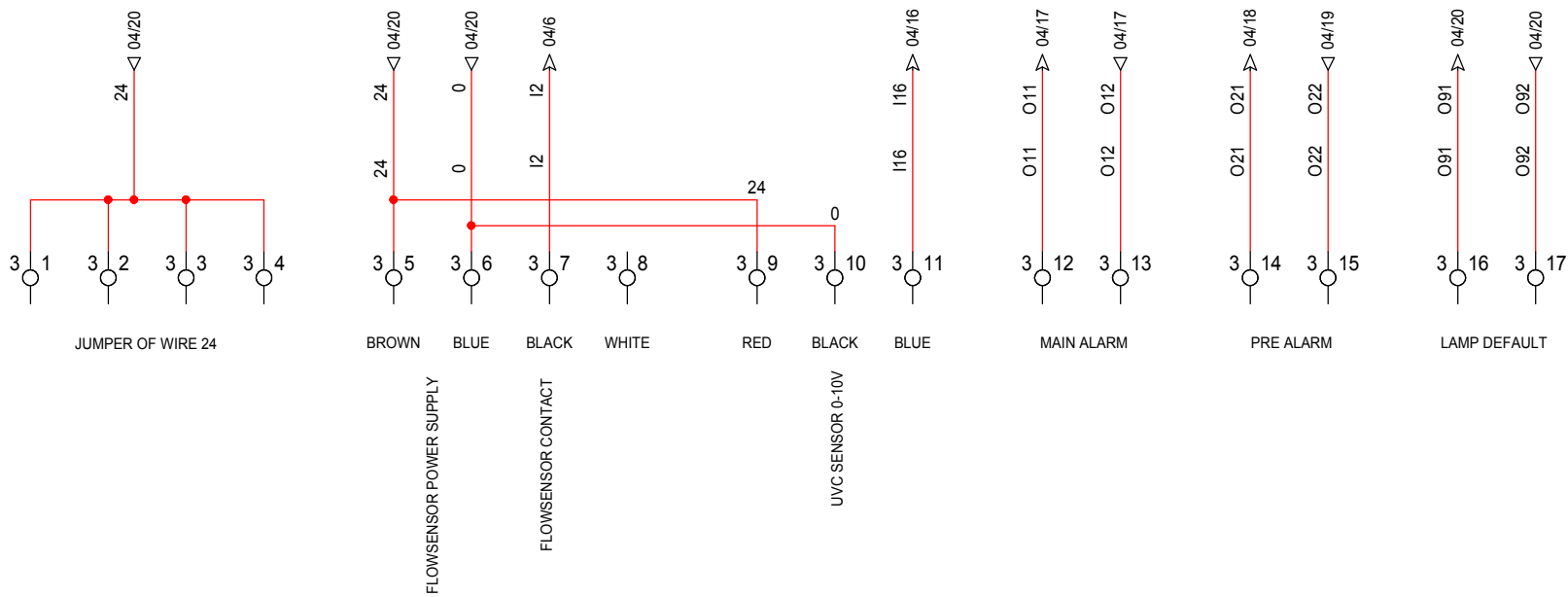
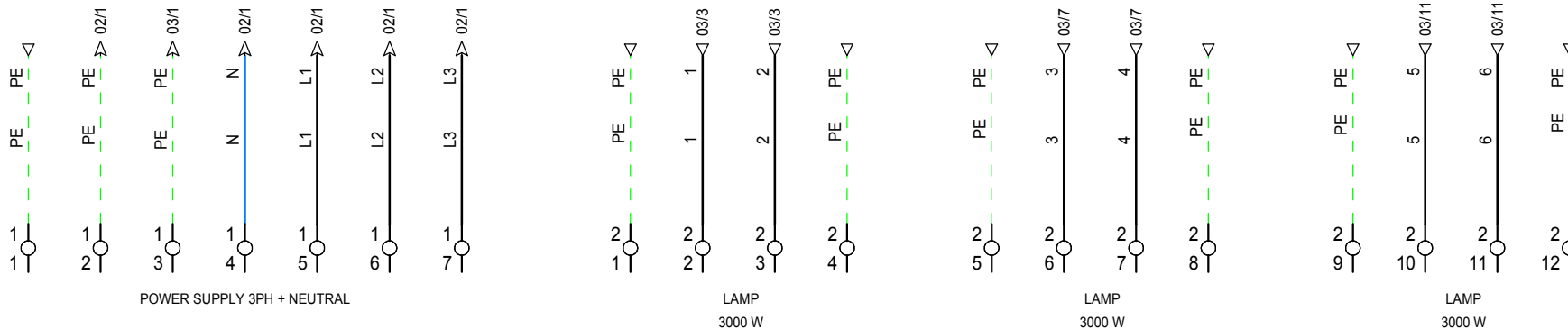

550 mm

750 mm

100 mm

100 mm

415 mm

118 mm

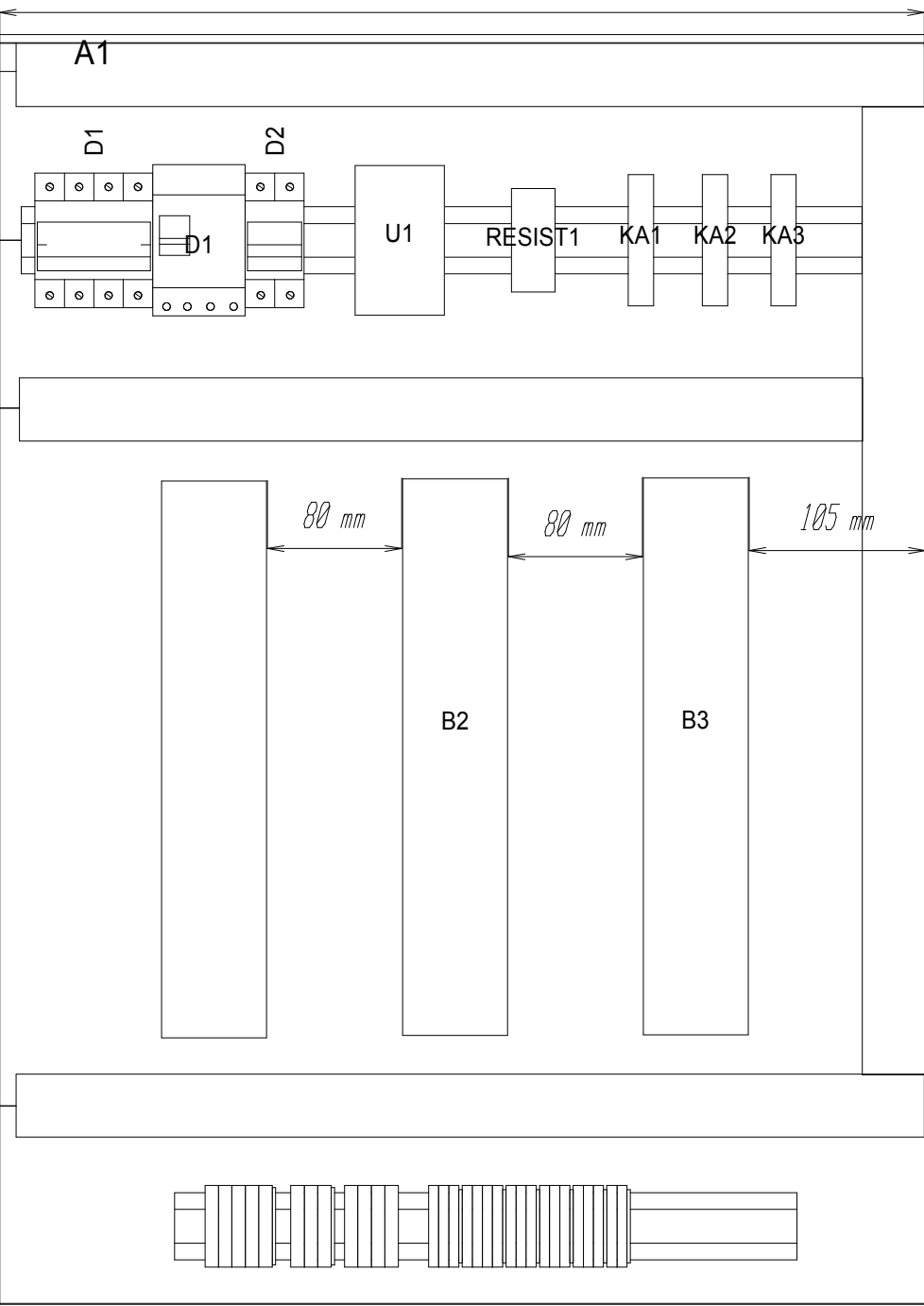

+ IMPLANTATION

BIO UV
ZAC DE LA PETITE CAMARGUE
34400 LUNEL

DRAWN :				
CHECKED :				
DATE OF CREATION :	23/10/08			
INDEX	DATE	MODIFICATION	DES.	

Document n° :

MP 340 EL

SHEET
06
◀ 05 07 ▶
Software SEE v. 3.00

REFERENCE	DESIGNATION	TAG	QTY
ELE000798	FIXING FOR CONTACT OR LED COMPONENT M22	H1\H2\H3\S1	4
ELE002161	POWER SUPPLY 24VDC 1.2A	U1	1
BAL004270	3kW MP BALLAST	B(1-3)	3
ELE004495	DIFFERENTIAL BLOCK 4P 40A 30mA	D1	1
ELE000169	TERMINAL BLOCK GREY 4mm2 039061	1-5\1-6\1-7\2-10\2-11\2-2\2-3\2-6\2-7\3-1\3-10\3-11\3-12\3-13\3-14\3-15\3-16\3-17\3-2\3-3\3-4\3-5\3-6\3-7	26
		3-8\3-9	
ELE000824	TERMINAL BLOCK FOR NEUTRAL 4mm²	1-4	1
ELE000173	TERMINAL BLOCK, INSULATE CASE, GREEN/YELLOW 4mm² 039371	2-1\2-12\2-4\2-5\2-8\2-9\1-3	7
ELE000174	TERMINAL BLOCK, INSULATE CASE, GREEN/YELLOW 6mm² 039372	1-2\1-1	2
ELE002051	RESISTOR BOX	RESIST1	1
ELE002800	UVC SENSOR 0-10V CABLE	--	1
ELE001214	LAMP CABLE H07RN-F 4G2.5	-	2
ELE000306	SI1000/SI5000 CABLE	--	1
ELE002052	PARTITION PF N2 FOR RESISTOR BOX	RESIST1	2
ELE000175	TERMINAL PARTITION 4mm²	1-1\3-1	7
ELE000215	CABINET 3D 800x600x300 83057	-	1
ELE000244	CABLE CLAMP COLLAR 98x2.5mm	-	20
ELE000271	ROTATIVE COMMUTATOR, 2 POS	S1	1
ELE004425	CIRCUIT BREAKER 2P 4A CURVE C	D2	1
ELE004497	CIRCUIT BREAKER 4P 25A CURVE C	D1	1
ELE000275	NO CONTACT	S1	1
ELE000272	COMPONENT LED , 18-30V AC/DC, GREEN	H2	1
ELE000274	COMPONENT LED , 85-264VAC, WHITE	H1	1
ELE001303	COMPONENT LED , 18-30V AC/DC, RED	H3	1
ELE000245	ADHESIVE SUBBASE 19x19mm	-	10
ELE000277	LABEL 27x18 ZBY	H1\H2\H3\S1	4
ELE002805	WIRE 0.5mm² RED	--	1
ELE000305	WIRE 0.75mm² BLUE	--	1
ELE000304	WIRE 0.75mm² BLACK	--	1
ELE000367	WIRE 0.75mm² GREEN/YELLOW	--	1
ELE000757	WIRE 6mm² GREEN/YELLOW	---	1
ELE000750	WIRE 2.5mm² BLUE	--	1
ELE000134	WIRE 2.5mm² BLACK	--	1
ELE000752	WIRE 2.5mm² GREEN/YELLOW	--	1
ELE002710	SOCKET CLADDING Ø18-34mm	-	1
ELE002587	WIREWAY 25x25mm 2m	---	1

SHEET 07

08
06
Software SEE V. 3.00

MP 340 EL PARTS LIST

DATE	NAME	N°:	
24/12/2008			
24/12/2008			
24/12/2008			

BIO UV

ZAC DE LA PETITE CAMARGUE
34400 LUNEL

