

CARACTERÍSTICAS TÉCNICAS TECHNICAL CHARACTERISTICS

Spear Nozzle es la tobera más polivalente para el diseño de cualquier fuente ornamental.

Están fabricadas en acero inoxidable AISI 304, que proporciona una gran robustez y resistencia a la oxidación, y proporciona un acabado más elegante en la fuente.

Dispone de una rótula ajustable hasta 20°, para corregir la salida del chorro en caso de mala alineación de colectores o tubos, o para crear parábolas sin accesorios adicionales.

Spear Nozzle is the most polyvalent nozzle for the design of any ornamental fountain.

They are made of AISI 304 stainless steel, which provides high sturdiness and rusting resistance, and provides a stylish finish to the fountain.

It has an 20° adjustable joint to correct the jet outlet in case of misalignment of manifolds or pipes, or to create parabolas without additional accessories.



FRESH WATER ✓

POOL WATER* ✓

SEA WATER ✗

* WITHOUT SALT ELECTROLYSIS

TOBERAS DE LANZA / SPEAR NOZZLE

| DESCRIPCION DESCRIPTION | SPEAR NOZZLE 4 | | SPEAR NOZZLE 6 | | SPEAR NOZZLE 8 | | SPEAR NOZZLE 10 | | SPEAR NOZZLE 12 | | SPEAR NOZZLE 14 | | SPEAR NOZZLE 16 | | SPEAR NOZZLE 20 | |
|--|--------------------|-----|--------------------|-----|--------------------|-----|---------------------|-----|-------------------|-----|-------------------|-----|-----------------------|------|-----------------------|------|
| REFERENCIA REFERENCE | 67496 | | 66639 | | 66640 | | 66641 | | 66642 | | 66643 | | 66644 | | 66645 | |
| ENTRADA / INLET DIAM CHORRO (A) JET DIAM (A) | G 3/8" M Ø 4 mm | | G 3/8" M Ø 6 mm | | G 1/2" M Ø 8 mm | | G 1/2" M Ø 10 mm | | G 1" M Ø 12 mm | | G 1" M Ø 14 mm | | G 1-1/2" M Ø 16 mm | | G 1-1/2" M Ø 20 mm | |
| DIMENSIONES ØCxB DIMENSIONS ØCxB | Ø21x52 mm | | Ø21x52 mm | | Ø24x76 mm | | Ø24x76 mm | | Ø36x111 mm | | Ø36x111 mm | | Ø61x167 mm | | Ø61x167 mm | |
| ALTURA CHORRO [m] JET HEIGHT [m] | l/min | m | l/min | m | l/min | m | l/min | m | l/min | m | l/min | m | l/min | m | l/min | m |
| 0,5 | 2,4 | 0,6 | 4,9 | 0,6 | 9,6 | 0,7 | 15,8 | 0,8 | 25,4 | 1,0 | 31 | 0,9 | 46 | 1,0 | 70 | 1,2 |
| 0,75 | 2,9 | 1,0 | 6,1 | 0,9 | 11,6 | 0,9 | 19,3 | 1,1 | 30,2 | 1,3 | 38 | 1,2 | 55 | 1,3 | 80 | 1,3 |
| 1 | 3,4 | 1,2 | 7,2 | 1,2 | 13,3 | 1,3 | 21,9 | 1,4 | 33,6 | 1,5 | 44 | 1,4 | 62 | 1,5 | 87 | 1,5 |
| 1,25 | 3,8 | 1,5 | 8,5 | 1,4 | 15,9 | 1,6 | 24,8 | 1,7 | 39,0 | 2,0 | 51 | 1,8 | 70 | 1,9 | 95 | 1,8 |
| 1,5 | 4,2 | 1,8 | 9,6 | 1,7 | 17,1 | 1,8 | 27,8 | 2,0 | 40,9 | 2,1 | 55 | 2,1 | 76 | 2,1 | 104 | 2,1 |
| 1,75 | 4,7 | 2,3 | 11,0 | 2,0 | 19,5 | 2,1 | 32,0 | 2,4 | 45,8 | 2,6 | 61 | 2,4 | 82 | 2,4 | 111 | 2,4 |
| 2 | 4,9 | 2,7 | 11,6 | 2,4 | 20,4 | 2,4 | 32,4 | 2,7 | 46,6 | 2,7 | 65 | 2,7 | 88 | 2,6 | 119 | 2,7 |
| 2,5 | 5,4 | 3,1 | 13,2 | 3,0 | 23,2 | 3,1 | 36,6 | 3,4 | 51,9 | 3,2 | 72 | 3,3 | 99 | 3,2 | 135 | 3,3 |
| 3 | 6,1 | 3,6 | 14,7 | 3,7 | 25,8 | 3,7 | 40,3 | 4,1 | 57,2 | 3,8 | 81 | 4,0 | 108 | 3,7 | 148 | 4,0 |
| 3,5 | 6,6 | 4,2 | 15,6 | 4,3 | 28,1 | 4,4 | 44,3 | 4,8 | 62,9 | 4,5 | 88 | 4,7 | 117 | 4,5 | 160 | 4,6 |
| 4 | 7,2 | 4,9 | 16,5 | 5,0 | 30,3 | 5,0 | 48,6 | 5,6 | 66,4 | 5,0 | 94 | 5,3 | 125 | 5,1 | 171 | 5,2 |
| 5 | | | | | | | 35,0 | 6,1 | 54,8 | 7,1 | 75,1 | 6,2 | 107 | 6,6 | 138 | 6,0 |
| 6 | | | | | | | | | 60,4 | 8,6 | 83,9 | 7,5 | 118 | 7,9 | 150 | 7,5 |
| 7 | | | | | | | | | | | 91,7 | 8,6 | 129 | 9,3 | 164 | 8,5 |
| 8 | | | | | | | | | | | 98,2 | 9,8 | 139 | 10,5 | 176 | 9,6 |
| 9 | | | | | | | | | | | | | 149 | 11,8 | 187 | 11,2 |
| 10 | | | | | | | | | | | | | 156 | 13,1 | 198 | 12,5 |
| 11 | | | | | | | | | | | | | | | 208 | 13,8 |
| 12 | | | | | | | | | | | | | | | 216 | 14,6 |
| 14 | | | | | | | | | | | | | | | | 348 |

66639 FT-06.18_ES+EN



CABLE INLET FITTING CABLE INLET FITTING

DIMENSIONES

DIMENSIONS

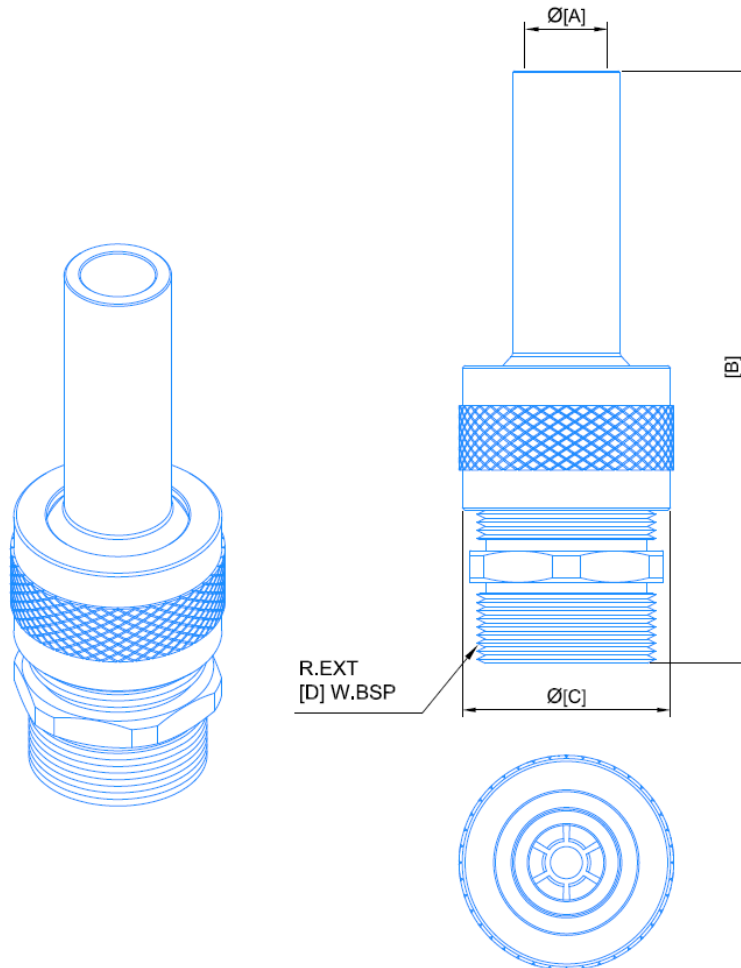

EJEMPLOS EXAMPLES

