

## LUMIPLUS ESSENTIAL FLAT PROJECTOR RGB 900



<b>FLAT PROJECTOR RGB +RC 900lm</b> <b>75822</b> 	Consumption	15 W (23 VA)
	Luminous flux	900 lm
	Rated Voltage	12 V AC
	IP68. Must always be installed submerged in water. Works with remote control code 75775 (included).	

<b>FLAT PROJECTOR RGB</b> <b>75823</b> 	Consumption	15 W (23 VA)
	Luminous flux	900 lm
	Rated Voltage	12 V AC
	IP68. Must always be installed submerged in water. Works with remote control code 75775 (not included).	

VOLTAGE:	12 V AC
FREQUENCY:	50/60 Hz
SERVICE LIFE:	L70-50,000 h
MAX. WATER TEMPERATURE:	30 °C
MAX. INSTALLATION DEPTH:	0,4 m
MAXIMUM WATER TREATMENT VALUES:	Chlorine: 2 mg/l Bromine: 5 mg/l Salt chlorinator (NaCl): 6 g/l Pool water pH: 7.2 and 7.6
MATERIALS:	Polyamide

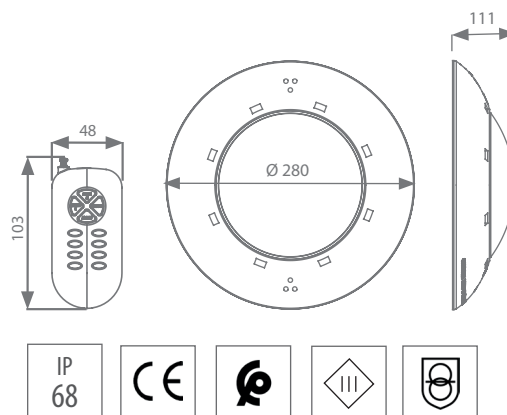

## PACKAGING AND PALLETIZATION

Volume/Single box (m <sup>3</sup> )	0,007
Weight/Single box (kg)	1,4
Units/Standard box	6
Volume/Standard box (m <sup>3</sup> )	0,052
Weight/Standard box (kg)	8,6
Units/Pallet	252
Volume/Pallet (m <sup>3</sup> )	2,54
Weight/Pallet (kg)	372

