

ABOVE-GROUND AUTOMATIC POOL COVER

NARBONNE MODEL



INSTALLATION AND MAINTENANCE MANUAL



Serial N°:

Revision number: B007-2012-10-05

TABLE OF CONTENTS

UNLOADING	2
TOOLS REQUIRED FOR ASSEMBLY	2
COMPONENTS OF THE AUTOMATIC POOL COVER	3
POSITIONING WITH SHARP CORNERS.....	4
POSITIONING WITH RAYS	4
ROLLER INSTALLATION.....	5
SLATS ASSEMBLY	7
SLATS DIRECTION.....	8
SLATS ASSEMBLING	8
STAIR SETTING	9
ELECTRICAL CONNECTIONS.....	10
PLAN OF WIRING.....	11
LIMIT SWITCH ADJUSTMENT	12
BRACKET AND STRAP POSITION	13
POSITION OF BRACKETS AND THE STRAPS FOR THE CAPCIR MODEL	13
SAFETY BRACKETS POSITIONING:.....	14



The structure is an element of ornament, do not sit down, do not climb on it, and do not use like solarium!







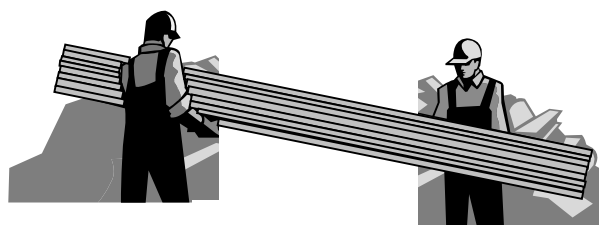





UNLOADING



OR



TOOLS REQUIRED FOR ASSEMBLY

-  Drill and drill bits for concrete Ø 6 and Ø10
-  Flat head screwdrivers
-  Phillips screwdrivers
-  Spirit level
-  10 - 13 – 17 wrench
-  Nippers
-  Wire strippers
-  5 and 6 mm Allen wrench
-  Hammer
-  Standard and long (10 m) measuring tape
-  Grease
-  Metal saw
-  Grinder with material disk

UNLOADING TIME

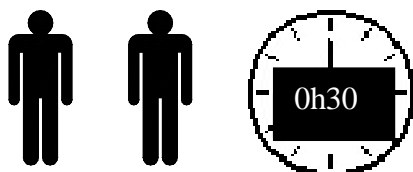

ASSEMBLY TIME

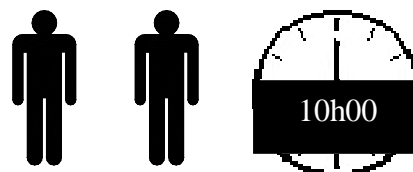

COMPONENTS OF THE AUTOMATIC POOL COVER



**1 Structure PVC or WOOD
(Shaft assembled on the structure):**

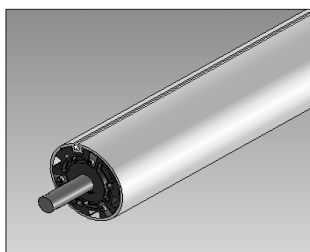

Roller Shaft



Slats and fixing Brackets assembly



Electrical box



Installation Instructions
Operation, care, winterising and maintenance instructions.

POSITIONING WITH SHARP CORNERS

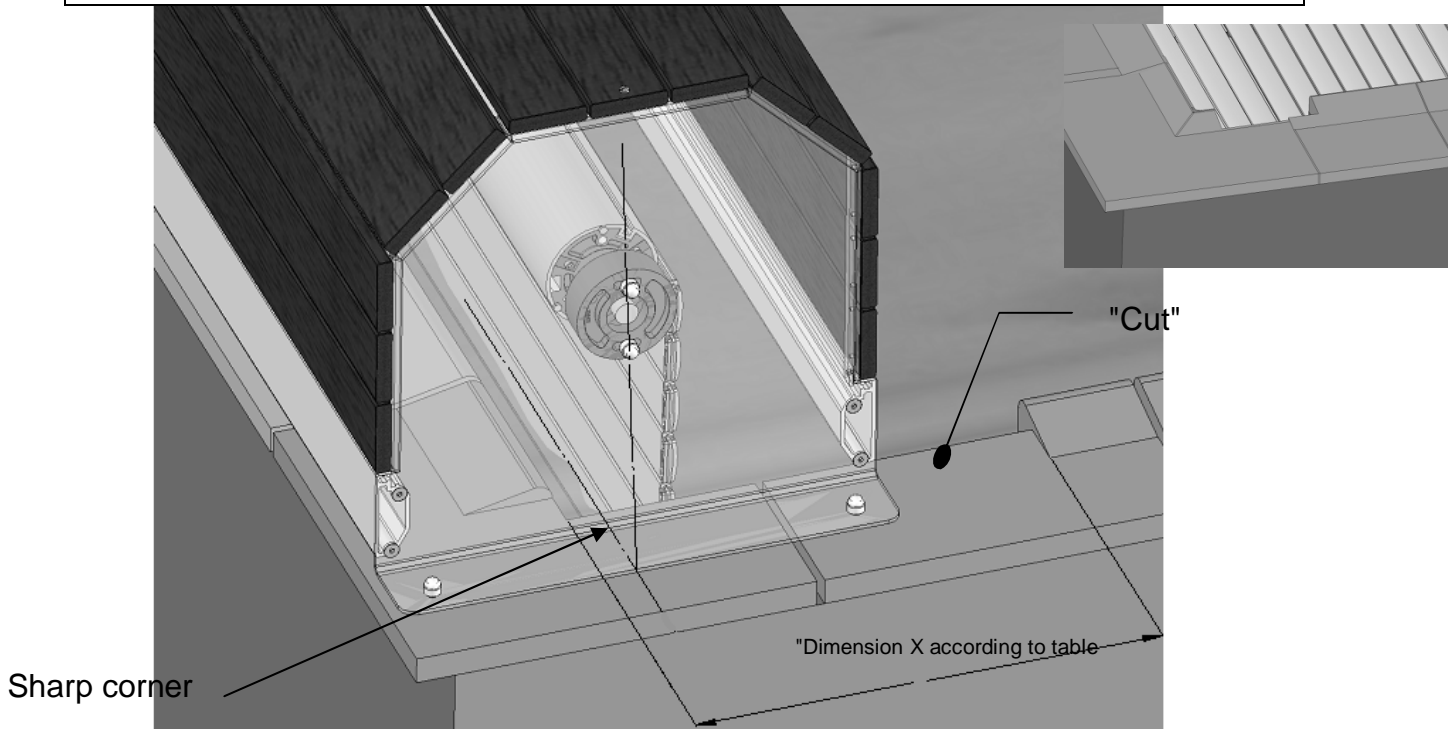

POSITIONING WITH RAYS

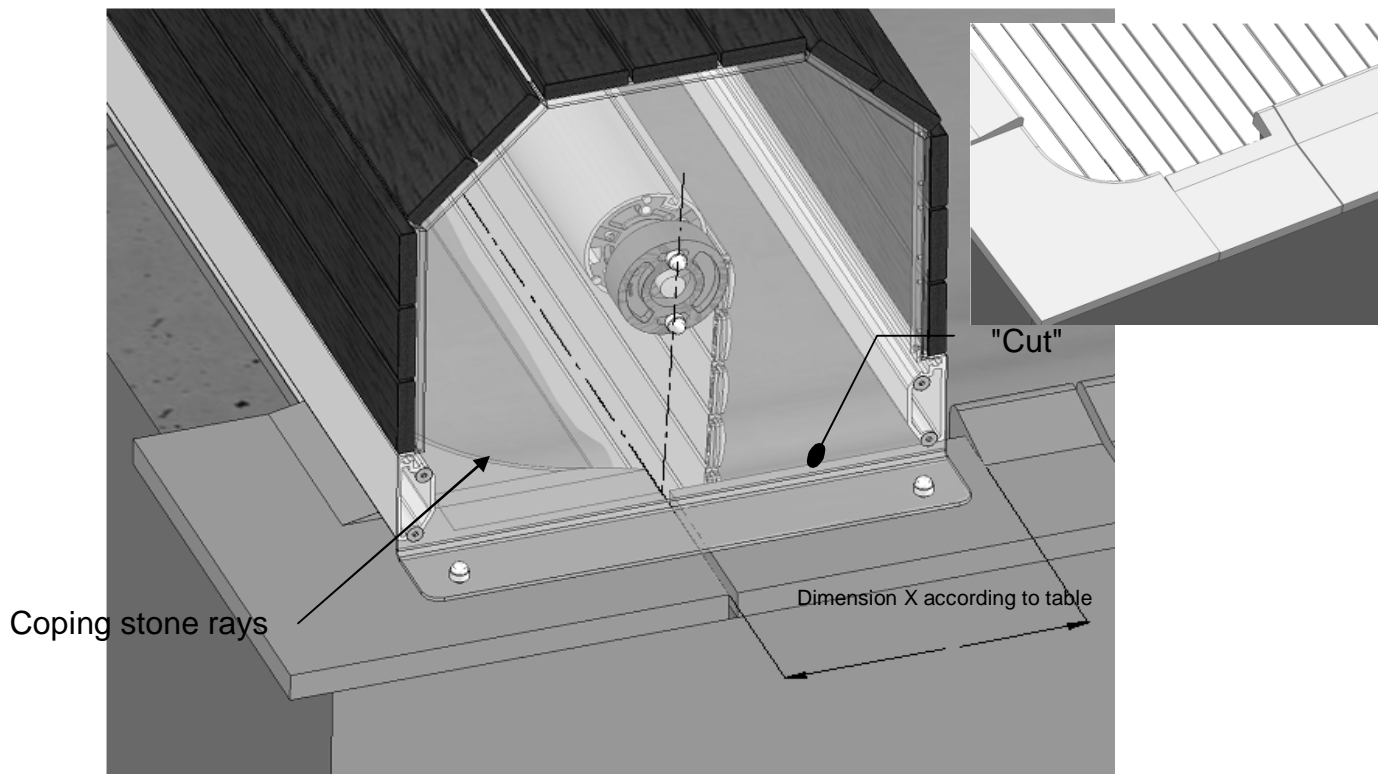

	POOL LENGTH					
Pool slats length	4 m	5 m	6 m	8 m	10 m	12 m
Dimension X in mm	250	265	285	305	335	350

Dimension X: Cut a piece of coping stone of variable length according to the diameter of slat roller, upon the roller shaft.

ROLLER INSTALLATION

- Position the roller as indicated in the diagram, making sure it is properly centred with respect to the pool. **It must be perfectly horizontal when installed (diagonals dimensions)**.
- If there are rays, the roller should be pushed forward to the pool to enable the slats to lower properly in its full width.

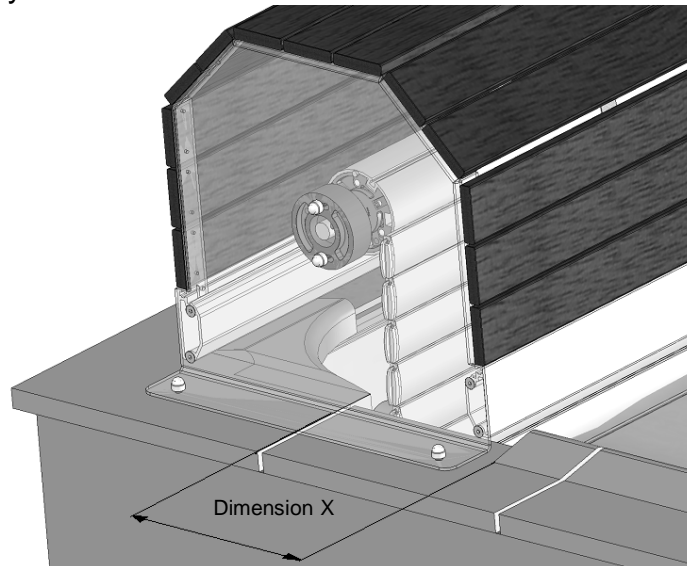

- Mark the position of the roller stand and polish or flatten the coping stone to obtain a flat horizontal, even surface for placing the stands.
- Cut the coping stone (dimension X) to make it easier for the slats to be lowered over the pool. Dimension X may vary according to the length of the pool; roller (roller diameter on the roller shaft). (See page 05/18 table dim. X).
- After assembling the roller and making the adjustments, position the two roller stands to the final position on the coping stone, using M10x75 Stainless Steel Bolts.
- Not to position it too behind swimming pool in order to avoid the friction of the blades on the nose of curbstones when the cover is completely rolled up and this particularly in the center of the roller

Note: If the skimmers are fixed along the length of the pool, we recommend replacing their existing flanges with 2 mm thickness Stainless Steel flanges to easier the slats way and avoid their blockage.

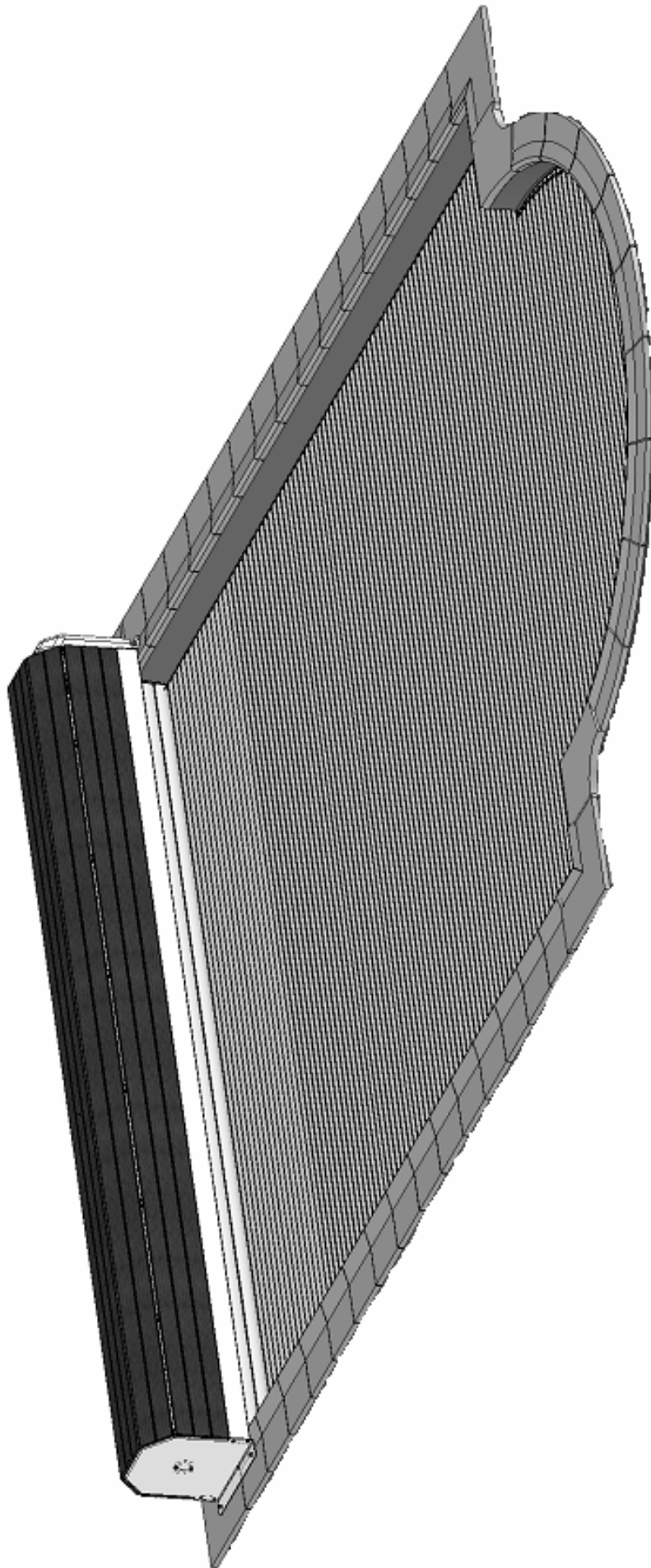

SLATS ASSEMBLY

* Immediately after taking the slats out of the packaging, they should be put into the water to prevent any possible deformation.

*The number of slats has been determined according to the length of the pool, though there are 4 extra slats.

* The first set of slats is easily recognisable as it has the straps to be fastening to the roller. (Long length straps).

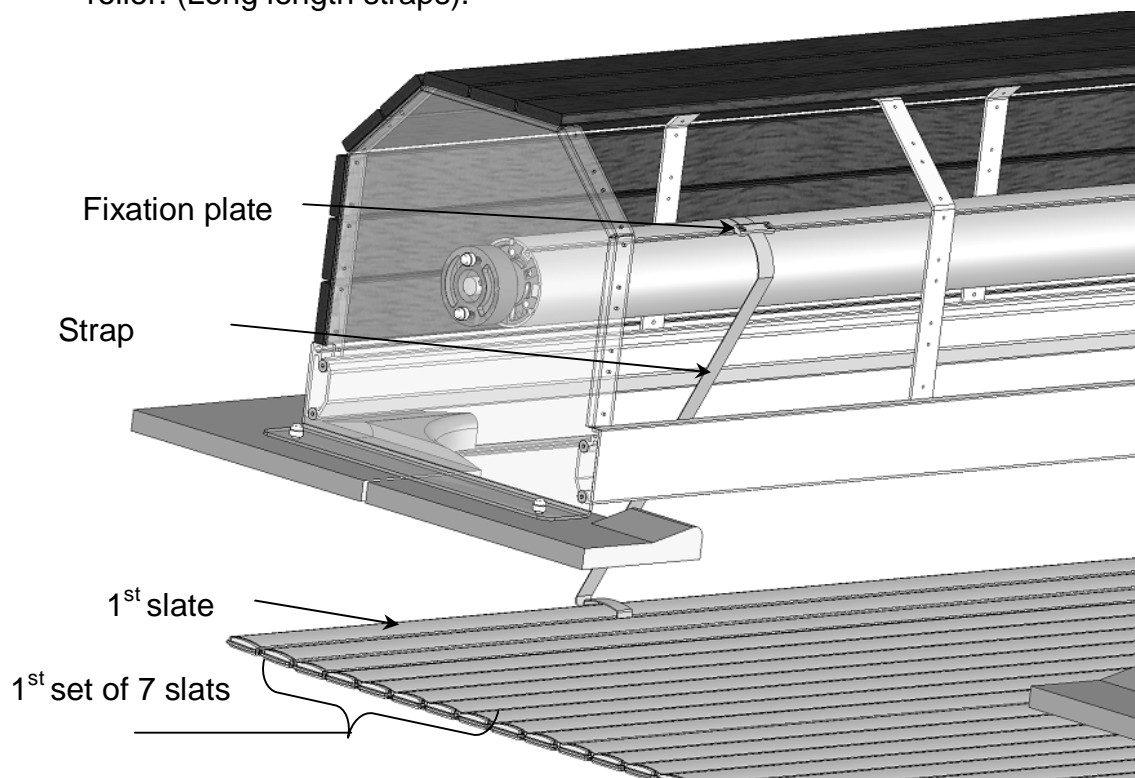

*Slide the strap under the fastening plates; tension it without pulling the slat out of the water

*Centre the cover in the pool leaving enough space on both sides.

*Tighten the attachment plates with a screwdriver

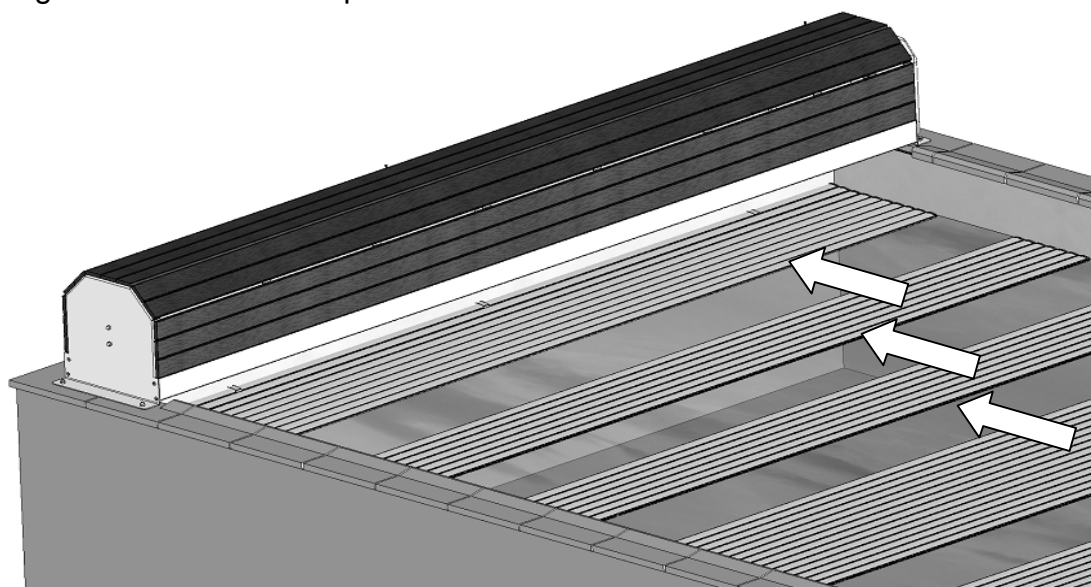

* Bring closer the set of 7 slats to assemble them.

Note: Slats should go down from the front of the roller shaft.

SLATS DIRECTION

* Identify the upper side of the slats (curved side).

* Identify the slats direction:

- Wing to the stair
- Groove to the roller shaft

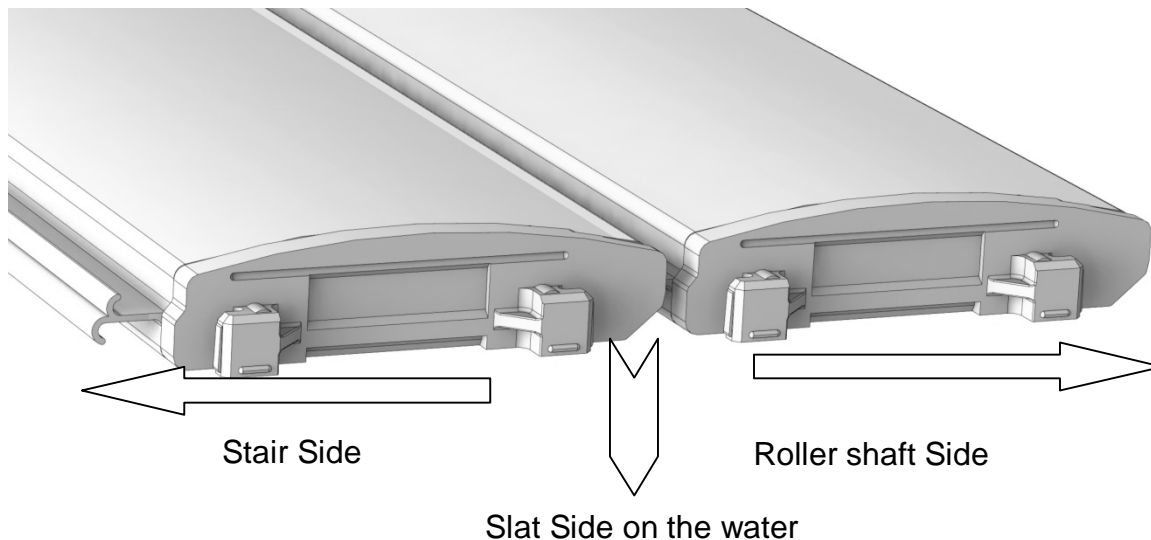

SLATS ASSEMBLING

Phase 1: Join the slats



Phase 2: Join the wing to the groove

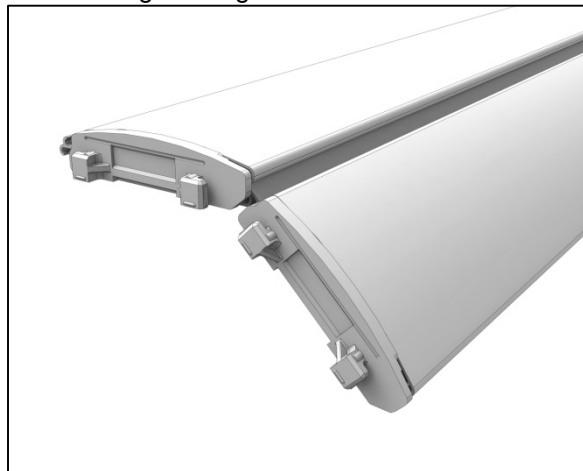

Phase 3: Move both slats down

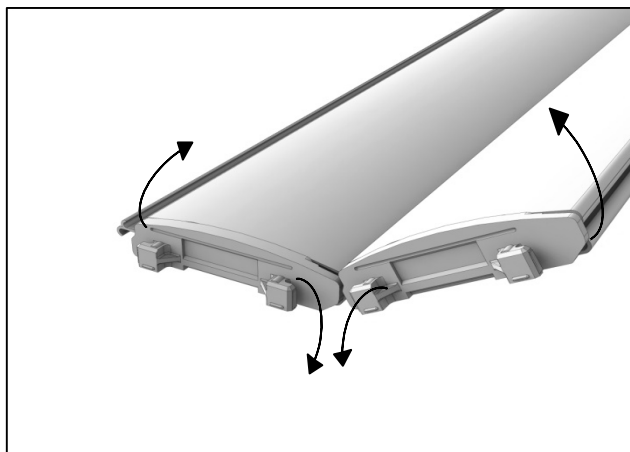

Phase 4: Move them up and carry on with it until slats are perfectly engaged.

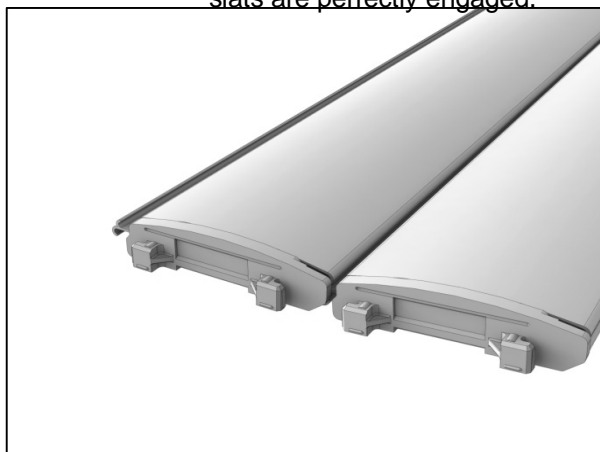

STAIR SETTING

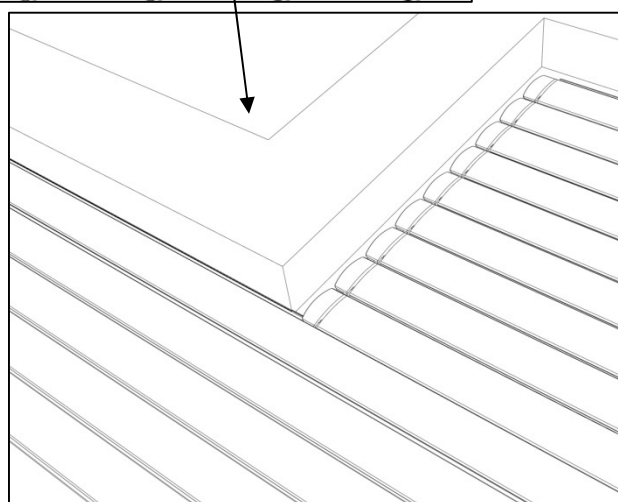
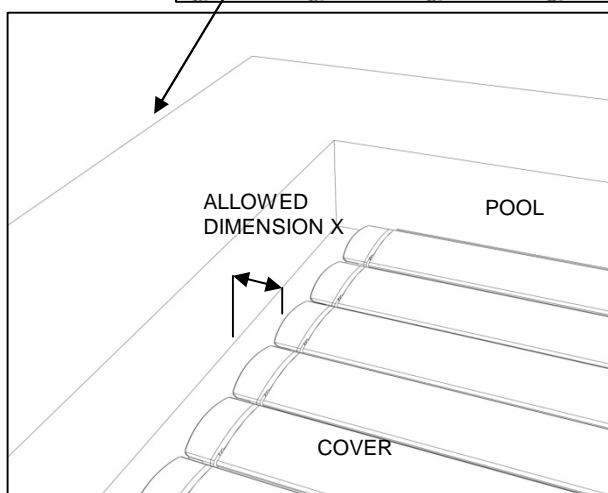
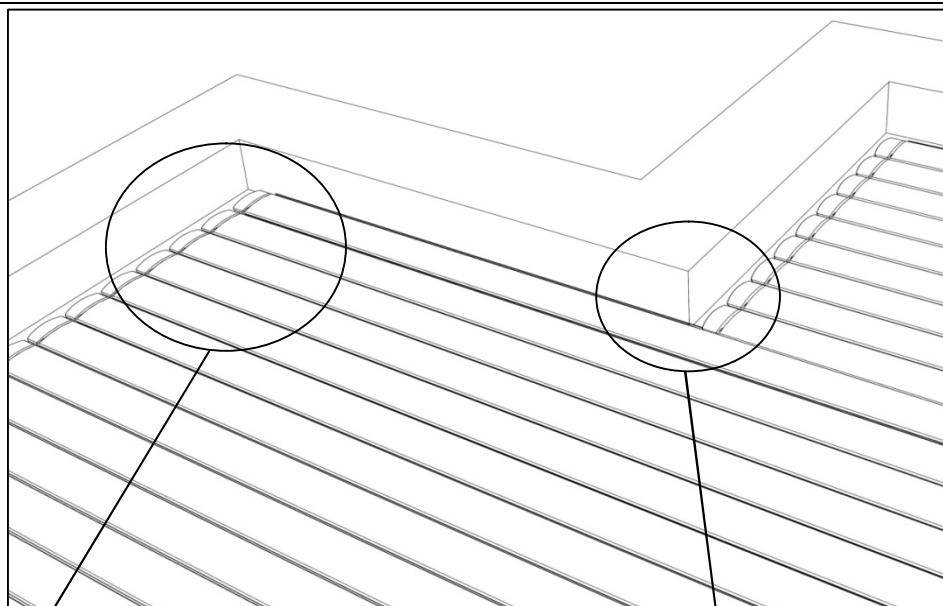

- 1°) Put the stair slats on the water
- 2°) Assemble the slats until the stairs are completely assembled.
- 3°) Centre the big width slats in the pool (allowed dimension X: from both sides of the pool)
- 4°) Centre the stair using this slat.

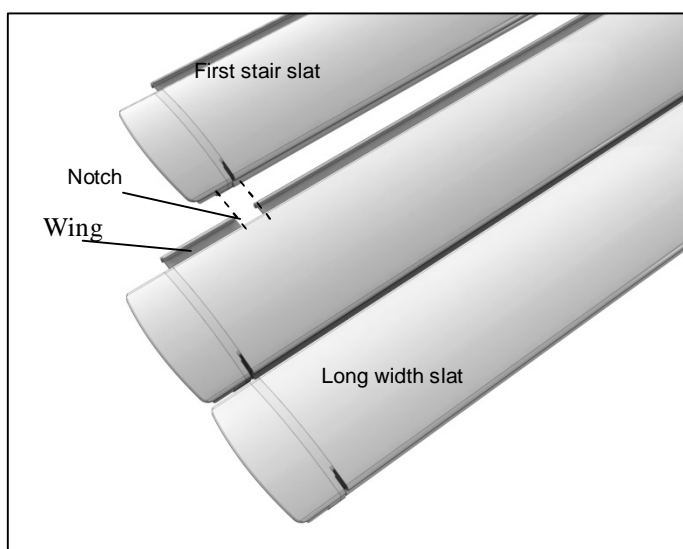

To assemble the stair slats to the pool slats, proceed as follows:

- ▶ Mark the position of both cap edges of the stair slat on the wing of the long width slat.
- ▶ Make two notches of a cap and wing dimension on both sides of the stair on the wing of the long width slat without hurting the waterproof of the slat.

ELECTRICAL CONNECTIONS

The electric installation must be made in accordance with C15100 and P91C by a properly trained and qualified electrician.

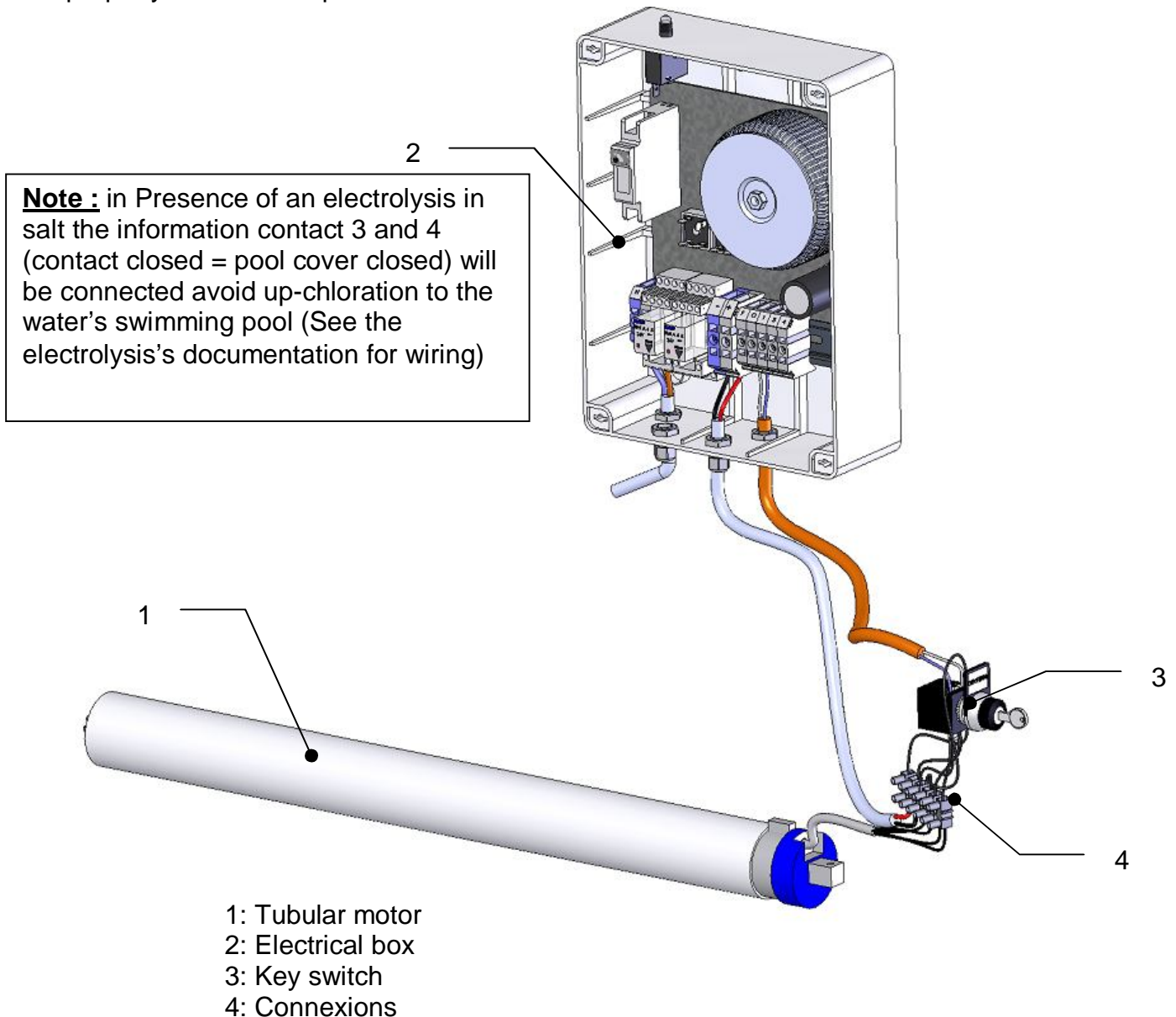

Note: The electrical box is located in the technical room of the swimming pool. Its power pack is carried out by a cable 3x2.5², and of a tension of 220 Volts, is protected by a differential circuit breaker from 30mA (not included)

Nota : in the case of a wiring of an electrolysis in salt.
Contact 1 = COMMUN
Contact 3 = Contact NORMALMENT CLOSED
Contact 4 = Contact NORMALMENT OPEN

PLAN OF WIRING

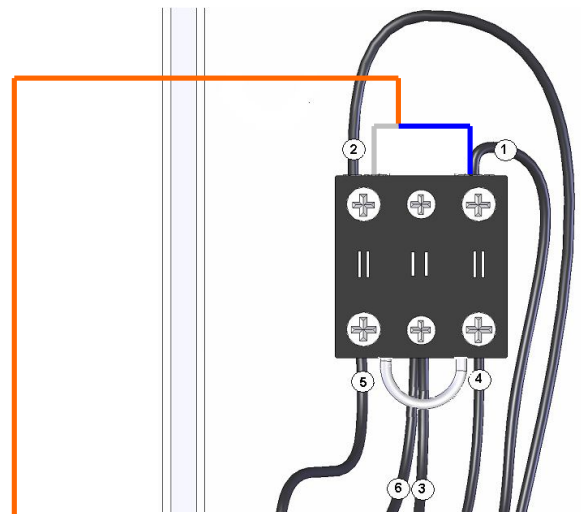
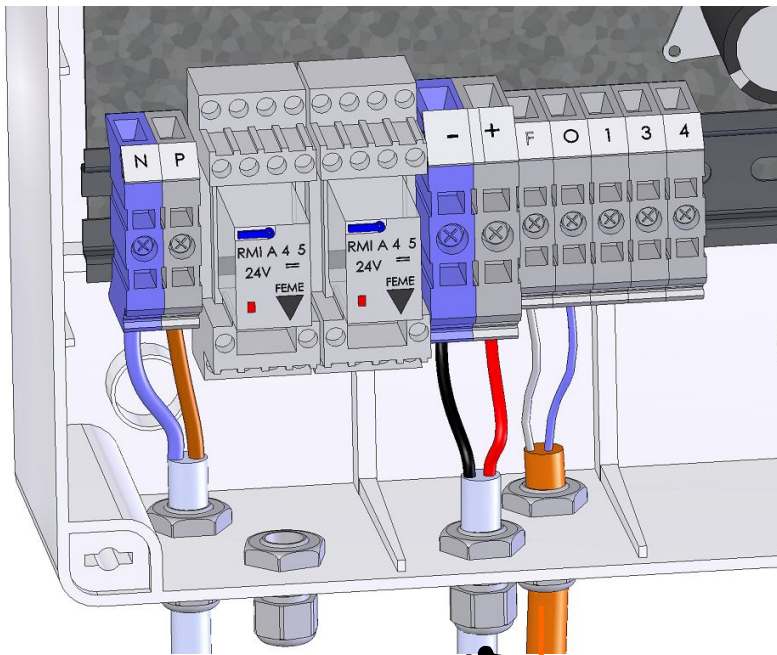

**Attention !
Wiring in the case of an
electrolysis in salt !**

Power cable
2x4² to 15m
2x6² to 15 at 25m
2x10² to 25 at 50m

Circuit breaker of
30 mA not
included

Electric cable
3x 2.5²
Tension 220 Volts

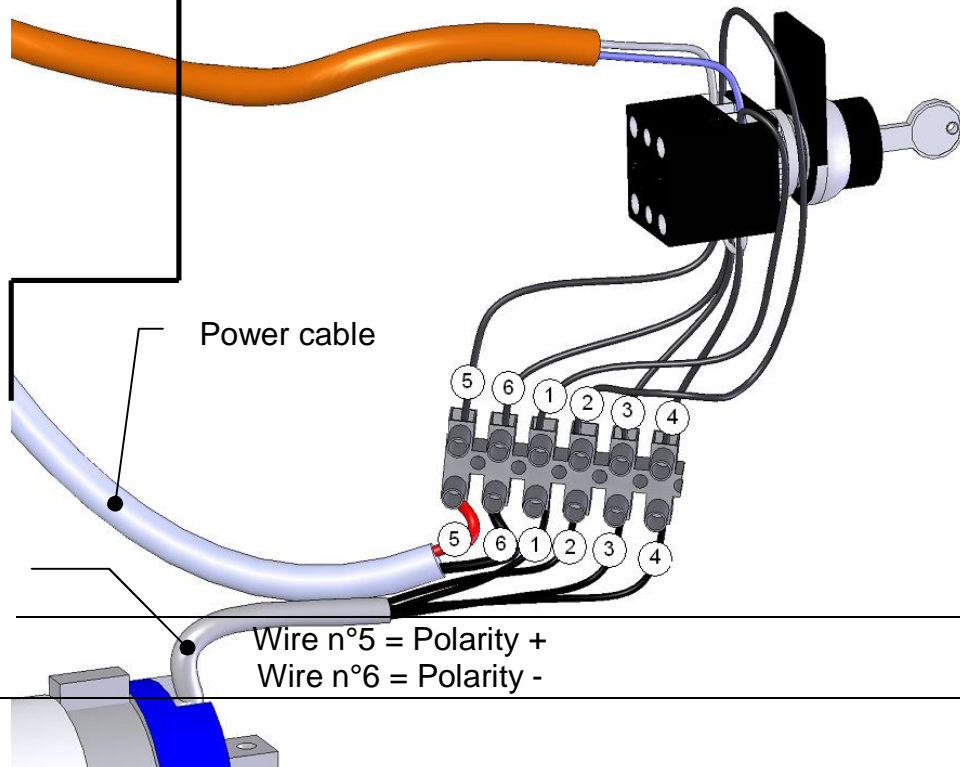

Wire n°5 = Polarity +
Wire n°6 = Polarity -

Note: The numbered reference marks from 1 to 6 are registered on black wire of the system all the 10 to 15 mm. Think of stripping the cable of the engine well, to see the reference marks!

NOT TO REVERSE POLARITIES + AND - ENGINE!!!

LIMIT SWITCH ADJUSTMENT

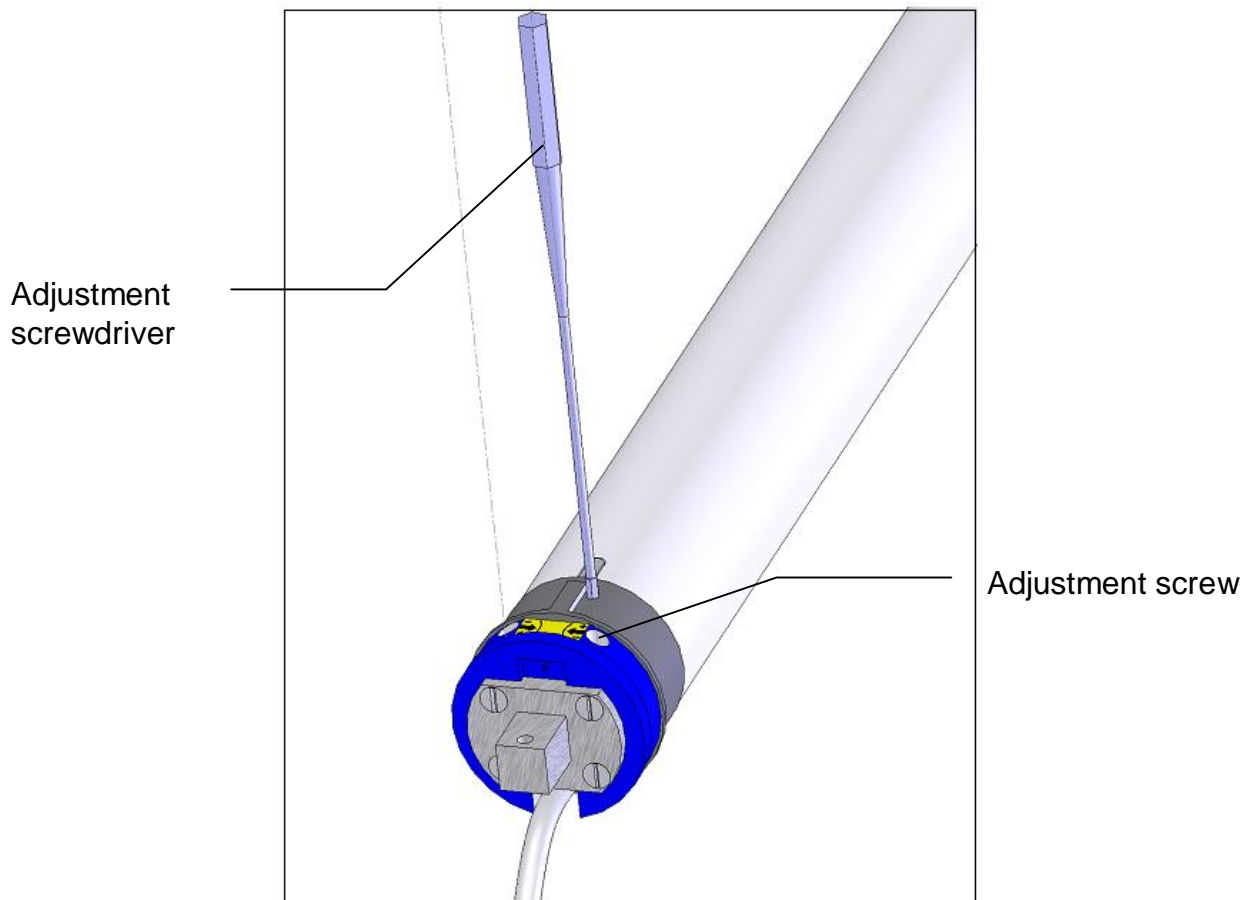

Adjust the limit switch, starting with the cover completely extended over the pool.

Adjustment of cover opening:

- 1: Turn the switch key to rolling-up position and check the rotational direction of the motor. If required, interchange 1 and 2 cables of the key switch.
- 2: Adjust the adjustment screw until to get the roller stops, in the correct position.
- 3: Roll up the cover and adjust the limit switch by turning the adjustment screw.

Adjustment of cover closing:

- 1: Turn the switch key to the cover closed position, until the pool is completely closed.
- 2: Adjust the screw for the closing limit switch such as we previously described.

Note:

Screw the adjustment screw (B) in the + direction to stop it later.
 Unscrew the adjustment screw (B) in the – direction to stop it earlier.

BRACKET AND STRAP POSITION

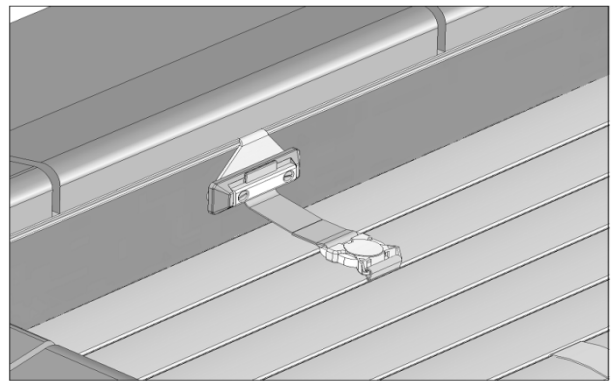
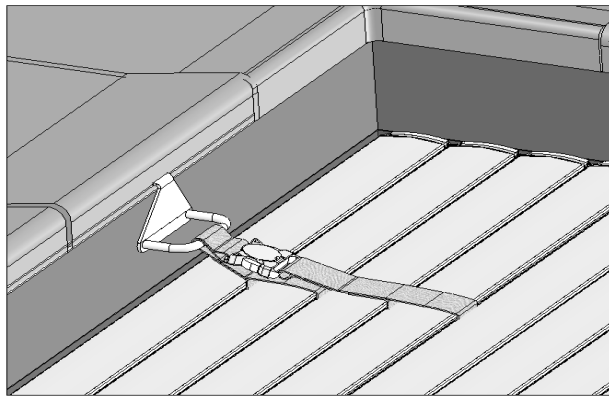
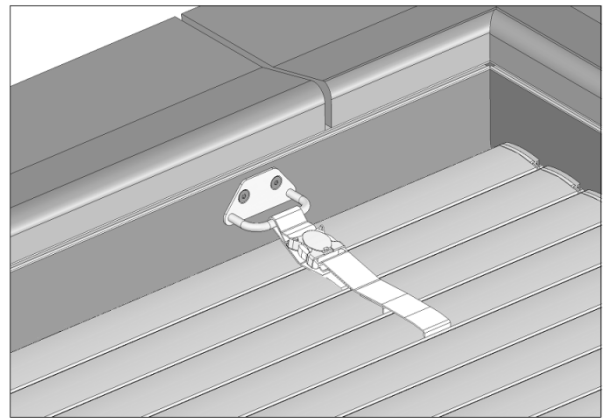
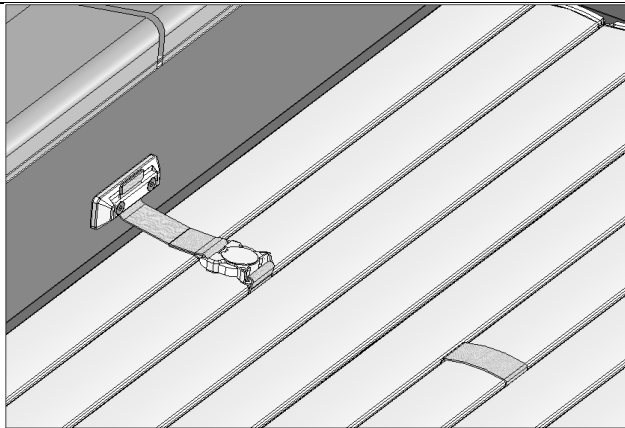

Warning: The position of the brackets is subject to the position of the skimmers in the pool. If these lasts bother the positioning of the safety Brackets, the positioning of the Brackets will be done taking into account the safety Brackets on the slats panels (If necessary move the straps)

POSITION OF BRACKETS AND THE STRAPS FOR THE CAPCIR MODEL

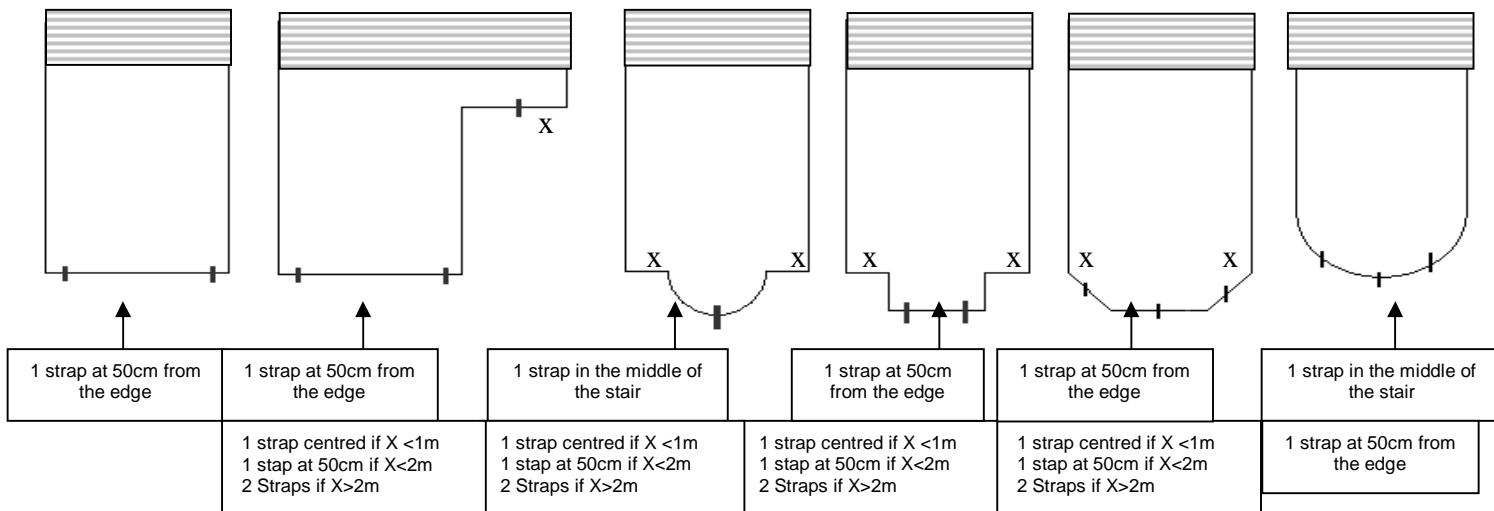

SAFETY BRACKETS POSITIONING:

ABS BRACKETS:

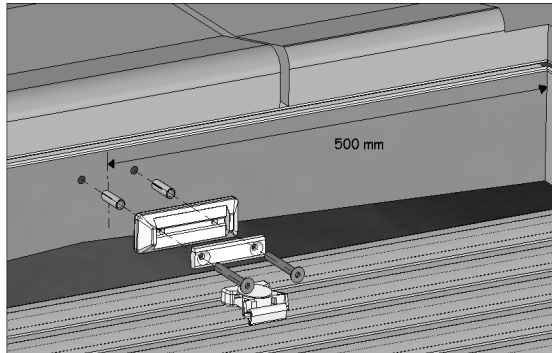

1) When positioning the brackets make sure the shaft of the brackets is placed at 500 mm from the edge of the pool.

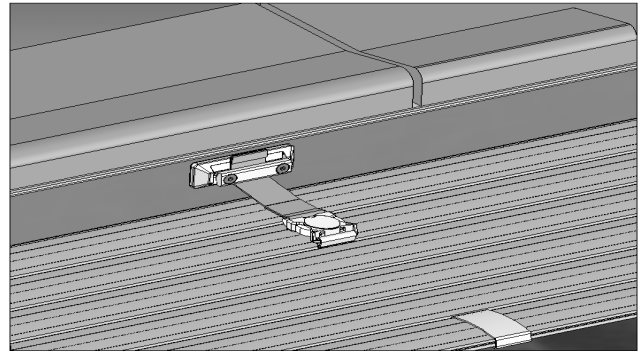

2) Pin the supports. Put the strap between the fixation plate and the bracket and keep the strap tense.

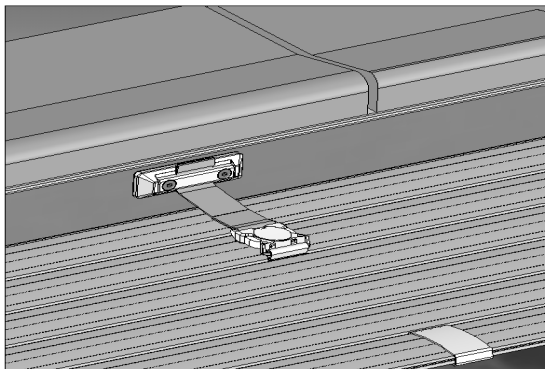

3) Tighten the screws until complete closing of the brackets.

Bracket Inox to be fixed to the wall + screws:

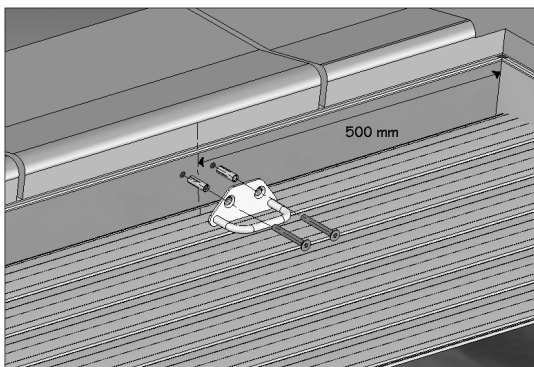

1) When positioning the safety brackets the shaft of the brackets must be return type placed at 500 mm from the edge of the pool.

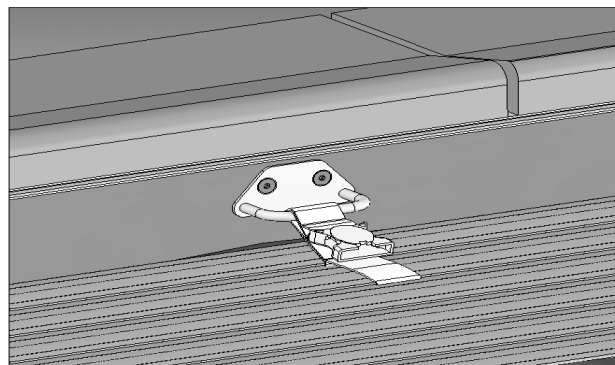

2) Screw the supports. Put the return safety strap.

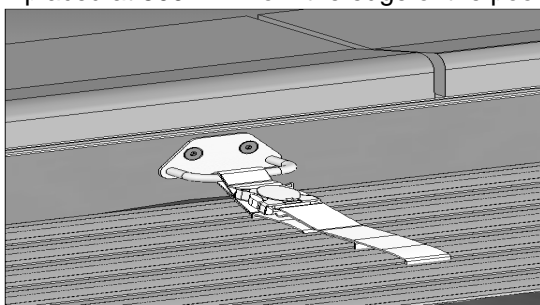

3) Clip both sides together.

Inox Bracket for model under construction + screws:

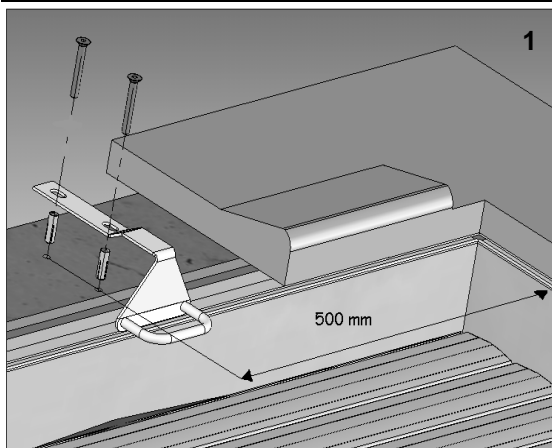

1) When positioning the safety brackets, The shaft of the brackets must be put at 500 mm from the edge of the pool.

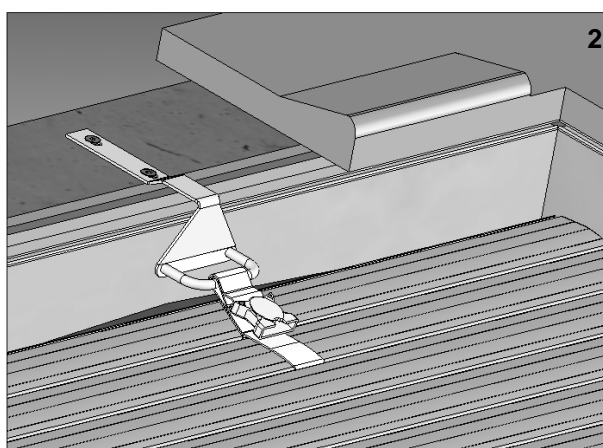

2) Put the pin M8 in the Ø10 wholes. Screw until complete closing of the brackets. Put the return safety strap in the brackets.

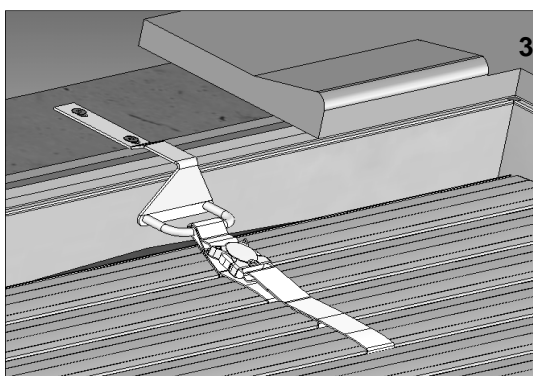

3) Clip both sides together.

Inox Brackets for renovation model + screws:

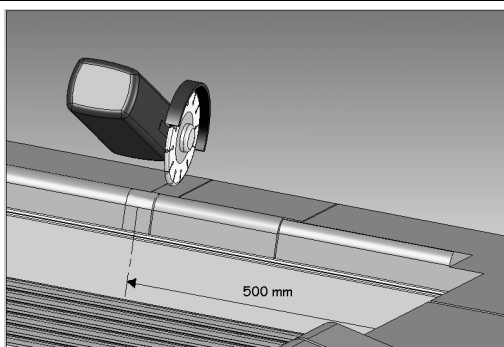

1) Cut the coping stone with a angle grinder

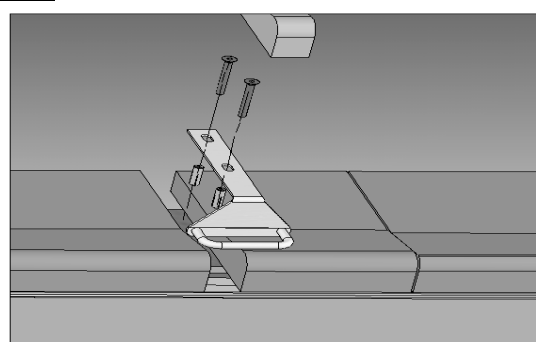
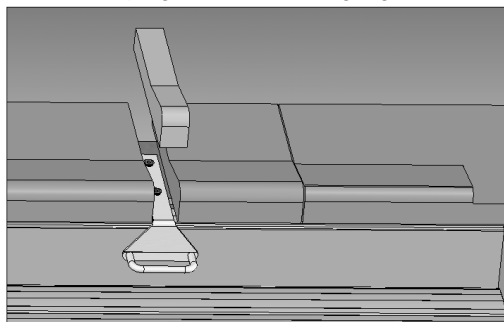

2) Make two Ø10 wholes. Place the M8 pin in the wholes. Screw until complete closing of the safety brackets.

Put the straps through as per drawings 2 and 3.

3) Replace the coping stone cut with an adequate product.

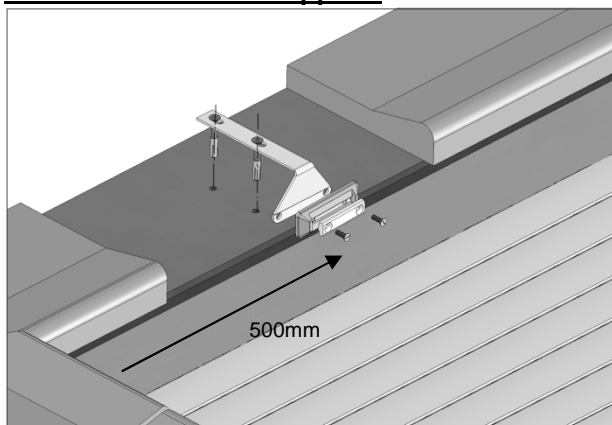
ABS brackets INOX support:

1) When placing the safety brackets, The shaft of the brackets must be placed at 500 mm from the edge of the pool.

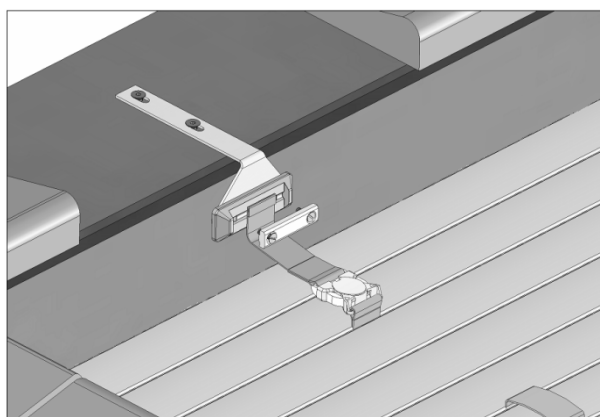

2) Screw the supports. Put the strap through the fixation plate and the strap. Clip both sides of the strap and keep it tense.

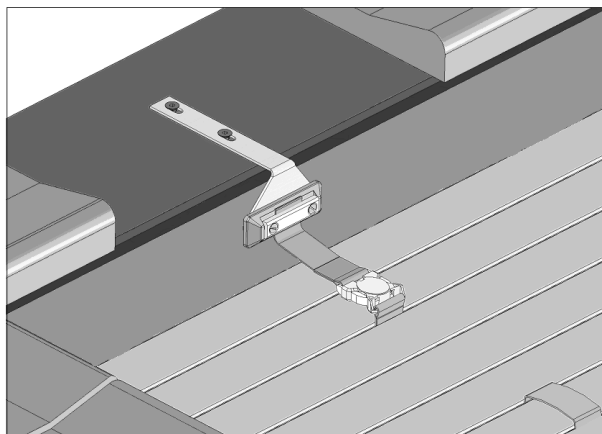

3) Tighten the screws until complete closing of the brackets.



ATTESTATION DE CONFORMITE

aux exigences de sécurité de la norme NF P 90-308 (mai 2004)
 Eléments de protection pour piscines enterrées non closes privatives à usage individuel ou collectif – Couvertures de sécurité et dispositifs d'accrochage

*Certificate of Conformity with the safety requirements of NF P 90-308 (May 2004) Standard
 Protective elements for in-ground, barrier-free, private or collective use swimming pools – Safety covers and securing devices*

Type de couverture de sécurité : Volet automatique hors-sol
Type of safety cover:

Modèle : CAPCIR
Model

Fabricant : EUROPEENNE DE COUVERTURE AUTOMATIQUE
Manufacturer: 661 rue J.B. Biot – Espace Polygone
 66000 PERPIGNAN

Demandeur de l'attestation : EUROPEENNE DE COUVERTURE AUTOMATIQUE
Applicant 661 rue J.B. Biot – Espace Polygone
 66000 PERPIGNAN

Au vu du rapport d'examen sur dossier référencé **E020017/CQPE/8**, la couverture essayée est déclarée conforme aux exigences du document de référence.

On the basis of the results contained in the report reference E020017 /CQPE/8, the safety cover tested is declared in conformity with the requirements of the above referenced document.

Trappes, le 15 novembre 2004

Le Chef de la Division
 Produits pour l'Enfance
 Head of Childhood Products Division

Nicole COURCAULT



Cette attestation est délivrée dans les conditions suivantes :

1. Elle ne s'applique qu'à l'article essayé et pour les essais réalisés ou pour les informations qui sont consignés dans le rapport référencé ci-dessus. "Le LNE décline toute responsabilité en cas de non-conformité d'un des éléments de l'article essayé pour lequel le demandeur a fourni au LNE un certificat ou une garantie de la conformité aux normes en vigueur, le demandeur étant seul responsable de la véracité des documents qu'il produit au LNE."
2. Elle n'implique pas qu'une procédure de surveillance ou de contrôle de fabrication ait été mise en place par le LNE.
3. La conformité à la norme référencée ci-dessus n'exonère pas de la conformité à la réglementation en vigueur.
4. Des copies peuvent être délivrées sur simple demande auprès du demandeur.

This certificate is issued under the following conditions:

1. It applies only to the tested item and to the tests or information specified in the report referenced above. "The LNE declines any responsibility in the event of non conformity for one of the elements of the article tested for which the applicant provided to the LNE a certificate or a guarantee of the compliance with the standards in force, the applicant being the only person responsible of the veracity of the documents that he produces to the LNE."
2. It does not imply that LNE has performed any surveillance or control of its manufacture.
3. The conformity to the above referenced standard does not exempt from the conformity to the regulation in force.
4. Copies are available upon request by the applicant.



WE RESERVE THE RIGHT TO CHANGE ALL OR PART OF THE FEATURES OF ARTICLES OR
CONTENTS OF THIS DOCUMENT, WITHOUT PRIOR NOTICE